

**CRASHWALL PLAN
PIER 3**

VIEW B-B

Notes:
Bars shall be drilled and grouted according to Section 584 of the Standard Specifications.
Concrete Sealer shall be applied only to exposed surfaces of the new concrete on Pier 3.
See sheet 16 of 20 for additional Bar Bend Details.

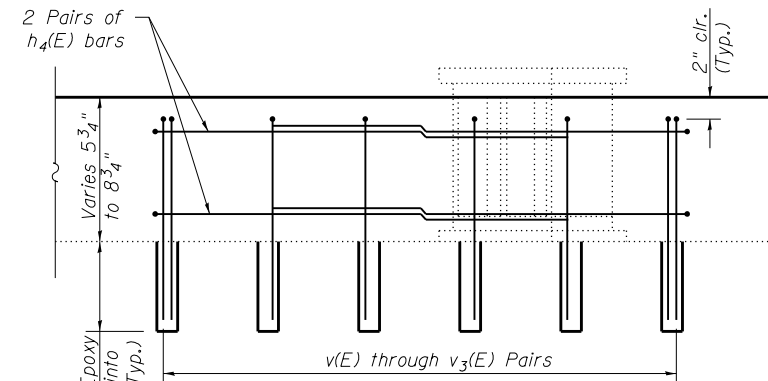

SECTION B-B

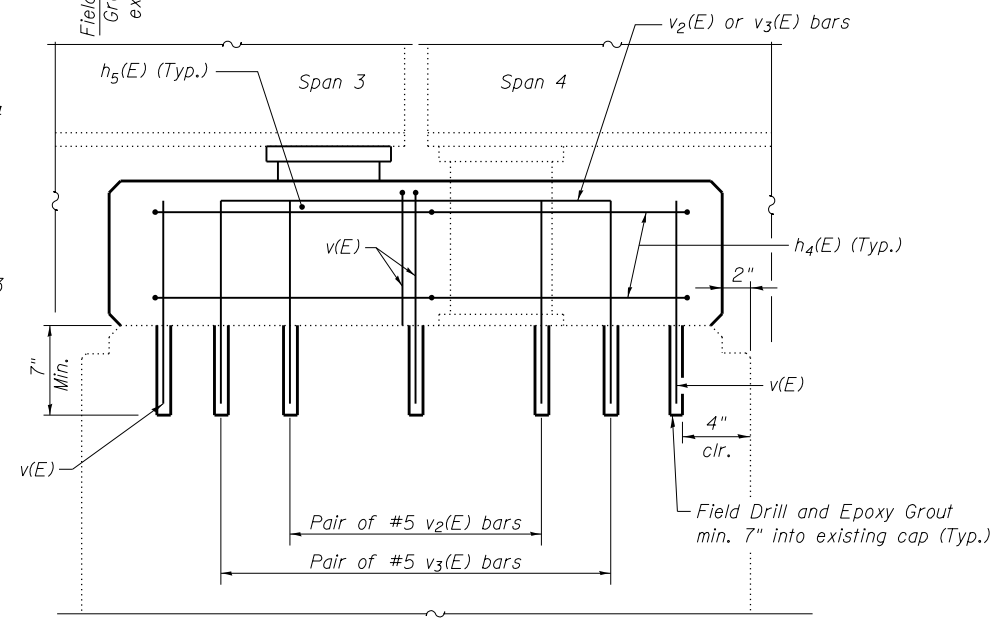

SECTION A-A

(All v(E) bars shown are drilled and grouted)
Side Retainers not shown for clarity.

**PIER 3
BILL OF MATERIAL**

Bar	No.	Size	Length	Shape
d(E)	18	#5	3'-3"	—
h ₄ (E)	20	#5	7'-1"	□
h ₅ (E)	5	#5	2'-3"	—
p ₄ (E)	6	#5	6'-4"	—
p ₅ (E)	4	#5	4'-0"	—
p ₆ (E)	3	#5	9'-6"	—
p ₇ (E)	3	#5	6'-6"	—
p ₈ (E)	18	#5	7'-2"	—
s ₃ (E)	52	#5	3'-8"	┌
s ₄ (E)	26	#5	5'-10"	┌
v(E)	20	#5	1'-1"	—
v ₁ (E)	10	#5	3'-4"	┌
v ₂ (E)	20	#5	2'-11"	┌
v ₃ (E)	20	#5	3'-9"	┌
Concrete Sealer		Sq. Ft.	240	
Concrete Structures		Cu. Yd.	5.8	
Reinforcement Bars, Epoxy Coated		Pound	1020	

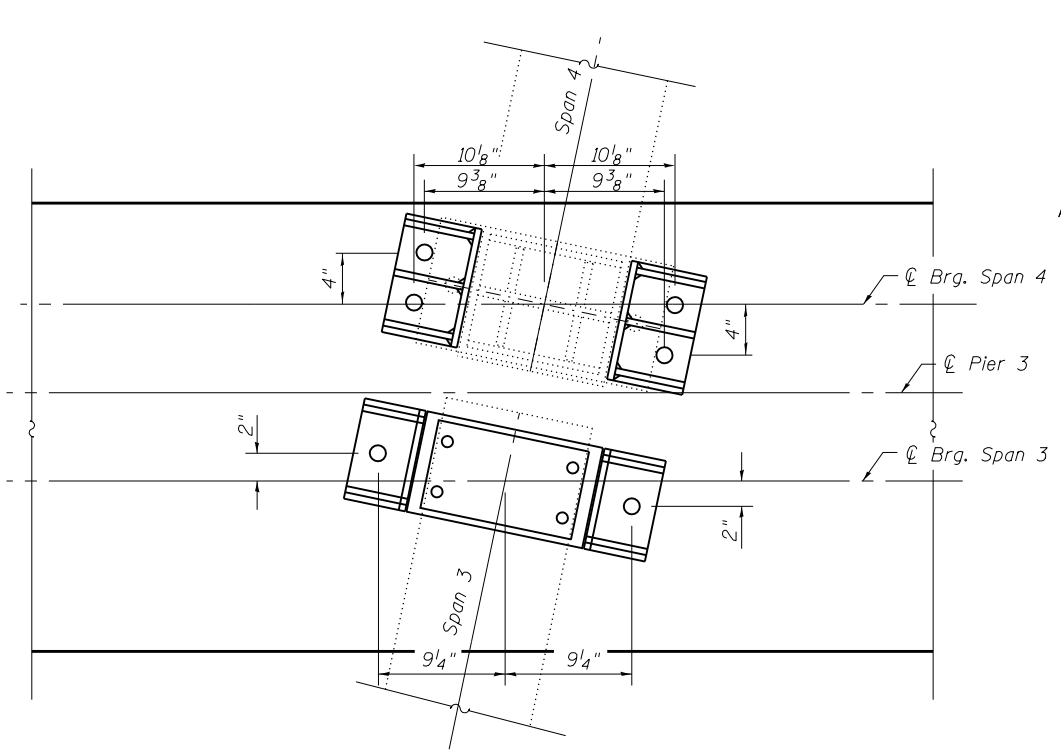

DETAIL A

(Showing Side Retainer & Anchor Bolt Layout)

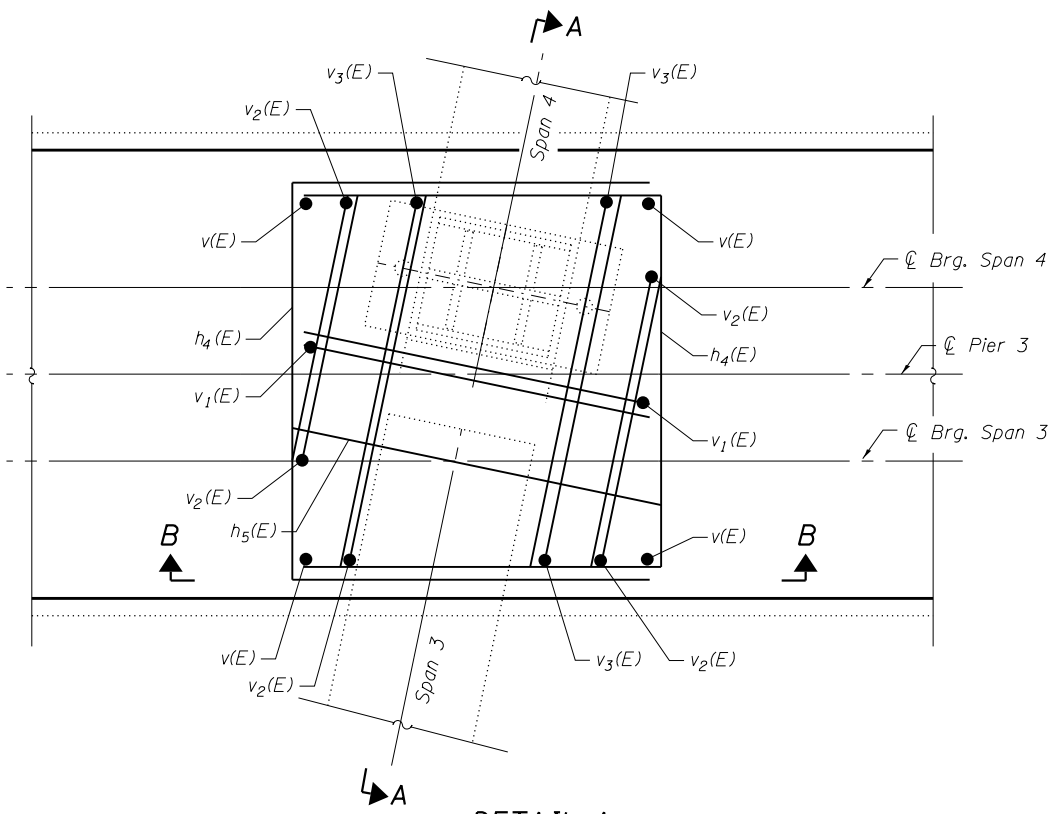

DETAIL A

(Showing Reinforcement)
(All reinforcement shown is #5 bars.)

S:\Proj\025-0062-00072_57-70\Bridges\Bridges\025-0062_TR over 57-70\025\Final\CADD_Design_Plans\0250062-74295-019.dgn

FILE NAME = 0250062-74295-019.dgn	USER NAME =	DESIGNED - B.B.	REVISED -
BERNHARDEN LOCHMULLER & ASSOCIATES, INC. 3 OAK DRIVE MARYVILLE, IL 62446 PHONE (618) 295-4666 FAX (618) 298-4666	CHECKED - A.C.S.	REVISIONS -	
PLOT SCALE =	DRAWN - B.B.	REVISIONS -	
PLOT DATE = 2:29:50 PM 8/15/2013	CHECKED - C.J.F.	REVISIONS -	

**STATE OF ILLINOIS
DEPARTMENT OF TRANSPORTATION**

**PIER 3 DETAILS
STRUCTURE NO. 025-0062**

SHEET NO. 19 of 20 SHEETS

F.A.I. RTE.	SECTION	COUNTY	TOTAL SHEETS	SHEET NO.
70	(25-4HB-2)I	EFFINGHAM	1760	1759
CONTRACT NO. 74295			ILLINOIS FED. AID PROJECT	