

# 4

**Letting September 20, 2024**

## **Notice to Bidders, Specifications and Proposal**



**Contract No. 62R26  
WILL County  
Section FAI 80 21 STRUCTURE 5  
Route FAI 80  
Project NHPP-HISX(005)  
District 1 Construction Funds**

Prepared by

Checked by

F



- 1. TIME AND PLACE OF OPENING BIDS.** Electronic bids are to be submitted to the electronic bidding system (iCX-Integrated Contractors Exchange). All bids must be submitted to the iCX system prior to 12:00 p.m. September 20, 2024 at which time the bids will be publicly opened from the iCX SecureVault.
- 2. DESCRIPTION OF WORK.** The proposed improvement is identified and advertised for bids in the Invitation for Bids as:

**Contract No. 62R26  
WILL County  
Section FAI 80 21 STRUCTURE 5  
Project NHPP-HISX(005)  
Route FAI 80  
District 1 Construction Funds**

The proposed project scope of work consists of the partial reconstruction of entrance and exit ramps proposed at the I-80 and I-55 interchange. The work also includes the construction of a new directional ramp for SB I-55 to EB I-80 with flyover bridge crossing over I-55, along with reconstruction of Mound Road Frontage Road, construction of new retaining walls and drainage improvements within the reconstruction limits. Related work proposed in this contract includes grading, pavement markings, signage, erosion control, landscaping, lighting, ITS, and replacement of the existing access control fencing. The project is located in the Village of Shorewood, City of Joliet, and Troy Township in Will County. Gross length is 3,109 ft (0.589 mi.) and net length is 2,919 ft (0.553 mi.).

- 3. INSTRUCTIONS TO BIDDERS.** (a) This Notice, the invitation for bids, proposal and letter of award shall, together with all other documents in accordance with Article 101.09 of the Standard Specifications for Road and Bridge Construction, become part of the contract. Bidders are cautioned to read and examine carefully all documents, to make all required inspections, and to inquire or seek explanation of the same prior to submission of a bid.  
  
(b) State law, and, if the work is to be paid wholly or in part with Federal-aid funds, Federal law requires the bidder to make various certifications as a part of the proposal and contract. By execution and submission of the proposal, the bidder makes the certification contained therein. A false or fraudulent certification shall, in addition to all other remedies provided by law, be a breach of contract and may result in termination of the contract.
- 4. AWARD CRITERIA AND REJECTION OF BIDS.** This contract will be awarded to the lowest responsive and responsible bidder considering conformity with the terms and conditions established by the Department in the rules, Invitation for Bids and contract documents. The issuance of plans and proposal forms for bidding based upon a prequalification rating shall not be the sole determinant of responsibility. The Department reserves the right to determine responsibility at the time of award, to reject any or all proposals, to re-advertise the proposed improvement, and to waive technicalities.

By Order of the  
Illinois Department of Transportation

Omer Osman,  
Secretary

INDEX  
FOR  
SUPPLEMENTAL SPECIFICATIONS  
AND RECURRING SPECIAL PROVISIONS

Adopted January 1, 2024

This index contains a listing of SUPPLEMENTAL SPECIFICATIONS and frequently used RECURRING SPECIAL PROVISIONS.

ERRATA Standard Specifications for Road and Bridge Construction (Adopted 1-1-22) (Revised 1-1-24)

SUPPLEMENTAL SPECIFICATIONS

<u>Std. Spec. Sec.</u>		<u>Page No.</u>
202	Earth and Rock Excavation .....	1
204	Borrow and Furnished Excavation .....	2
207	Porous Granular Embankment .....	3
211	Topsoil and Compost .....	4
407	Hot-Mix Asphalt Pavement (Full-Depth) .....	5
420	Portland Cement Concrete Pavement .....	6
502	Excavation for Structures .....	7
509	Metal Railings .....	8
540	Box Culverts .....	9
542	Pipe Culverts .....	29
586	Granular Backfill for Structures .....	34
630	Steel Plate Beam Guardrail .....	35
644	High Tension Cable Median Barrier .....	36
665	Woven Wire Fence .....	37
782	Reflectors .....	38
801	Electrical Requirements .....	40
821	Roadway Luminaires .....	43
1003	Fine Aggregates .....	44
1004	Coarse Aggregates .....	45
1010	Finely Divided Minerals .....	46
1020	Portland Cement Concrete .....	47
1030	Hot-Mix Asphalt .....	48
1061	Waterproofing Membrane System .....	49
1067	Luminaire .....	50
1097	Reflectors .....	57

RECURRING SPECIAL PROVISIONS

The following RECURRING SPECIAL PROVISIONS indicated by an "X" are applicable to this contract and are included by reference:

<u>CHECK SHEET #</u>	<u>PAGE NO.</u>
1 X Additional State Requirements for Federal-Aid Construction Contracts .....	59
2 X Subletting of Contracts (Federal-Aid Contracts) .....	62
3 X EEO .....	63
4 Specific EEO Responsibilities Non Federal-Aid Contracts .....	73
5 Required Provisions - State Contracts .....	78
6 Asbestos Bearing Pad Removal .....	84
7 Asbestos Waterproofing Membrane and Asbestos HMA Surface Removal .....	85
8 Temporary Stream Crossings and In-Stream Work Pads .....	86
9 X Construction Layout Stakes .....	87
10 Use of Geotextile Fabric for Railroad Crossing .....	90
11 Subsealing of Concrete Pavements .....	92
12 Hot-Mix Asphalt Surface Correction .....	96
13 X Pavement and Shoulder Resurfacing .....	98
14 Patching with Hot-Mix Asphalt Overlay Removal .....	99
15 Polymer Concrete .....	101
16 Reserved .....	103
17 Bicycle Racks .....	104
18 Temporary Portable Bridge Traffic Signals .....	106
19 X Nighttime Inspection of Roadway Lighting .....	108
20 English Substitution of Metric Bolts .....	109
21 Calcium Chloride Accelerator for Portland Cement Concrete .....	110
22 Quality Control of Concrete Mixtures at the Plant .....	111
23 X Quality Control/Quality Assurance of Concrete Mixtures .....	119
24 Reserved .....	135
25 Reserved .....	136
26 Temporary Raised Pavement Markers .....	137
27 Restoring Bridge Approach Pavements Using High-Density Foam .....	138
28 Portland Cement Concrete Inlay or Overlay .....	141
29 Portland Cement Concrete Partial Depth Hot-Mix Asphalt Patching .....	145
30 Longitudinal Joint and Crack Patching .....	148
31 Concrete Mix Design – Department Provided .....	150
32 X Station Numbers in Pavements or Overlays .....	151



## TABLE OF CONTENTS

LOCATION OF PROJECT .....	1
DESCRIPTION OF PROJECT .....	1
SOILS INFORMATION.....	2
CONTRACTOR COOPERATION .....	3
COORDINATION WITH ADJACENT AND/OR OVERLAPPING CONTRACTS .....	4
COOPERATION BETWEEN CONTRACTORS .....	6
COOPERATION WITH UTILITIES.....	7
PROGRESS SCHEDULE .....	7
WORK RESTRICTIONS .....	14
WINTER/LOW AIR TEMPERATURE WORK.....	15
MAINTENANCE OF ROADWAYS (D1) .....	15
STATUS OF UTILITIES (D1).....	16
PUBLIC CONVENIENCE AND SAFETY (D1) .....	20
COMPLETION DATE PLUS WORKING DAYS (D1) .....	21
FAILURE TO COMPLETE THE WORK ON TIME (D1).....	21
EMBANKMENT I (D1).....	22
RECLAIMED ASPHALT PAVEMENT FOR NON-POROUS EMBANKMENT AND BACKFILL (D1) .....	23
TEMPORARY PAVEMENT (D1) .....	24
HOT-MIX ASPHALT BINDER AND SURFACE COURSE (D1) .....	25
PAVEMENT REMOVAL, SPECIAL (D1) .....	30
COFFERDAM (TYPE 1) (IN-STREAM/WETLAND WORK) (D1) .....	31
AGGREGATE FOR CONCRETE BARRIER (D1).....	32
ENGINEER'S FIELD OFFICE TYPE A (SPECIAL) (D1) .....	32
TRAFFIC CONTROL PLAN (D1) .....	34
FRICTION AGGREGATE (D1).....	35
SLIPFORM PAVING (D1).....	38
HOT-MIX ASPHALT – MIXTURE DESIGN VERIFICATION AND PRODUCTION (D1) .....	38
GENERAL ELECTRICAL REQUIREMENTS .....	39
UNDERGROUND RACEWAYS .....	56
EXPOSED RACEWAYS.....	57
UNIT DUCT.....	61
WIRE AND CABLE.....	62
ELECTRIC UTILITY SERVICE CONNECTION (COMED).....	63
ELECTRIC SERVICE INSTALLATION .....	64

ROADWAY LUMINAIRE, LED .....	65
TEMPORARY LUMINAIRE, LED, ROADWAY .....	77
HIGHMAST LUMINAIRE, LED.....	80
BREAKAWAY DEVICE.....	91
LUMINAIRE SAFETY CABLE ASSEMBLY.....	92
MAINTENANCE OF LIGHTING SYSTEMS.....	93
TEMPORARY WOOD POLE, 50 FT., CLASS 4 .....	97
REMOVE TEMPORARY WOOD POLE.....	97
GROUNDING OF ITS SUBSYSTEMS (TSC T 420#8).....	98
ATMS INTEGRATION .....	99
MAINTAINING ITS DURING CONSTRUCTION.....	101
ELECTRICAL CABLE IN CONDUIT, 4C/NO. 18 SHIELDED LOOP LEAD-IN .....	103
INDUCTION LOOP .....	105
MODIFY EXISTING CONTROLLER AND CABINET.....	108
REMOVE EXISTING UNDERGROUND CONDUIT .....	109
KEEPING THE EXPRESSWAY OPEN TO TRAFFIC.....	110
FAILURE TO OPEN TRAFFIC LANES TO TRAFFIC.....	113
TRAFFIC CONTROL AND PROTECTION (EXPRESSWAYS).....	113
TRAFFIC CONTROL SURVEILLANCE (EXPRESSWAYS) .....	117
TEMPORARY INFORMATION SIGNING .....	118
TRAFFIC CONTROL FOR WORK ZONE AREAS .....	119
SPEED DISPLAY TRAILER (D1).....	120
RAISED REFLECTIVE PAVEMENT MARKER, REFLECTOR REMOVAL .....	121
RAISED REFLECTIVE PAVEMENT MARKER, REFLECTOR REPLACEMENT.....	122
MAST ARM SIGN PANELS.....	122
SIGN SHOP DRAWING SUBMITTAL .....	122
OVERHEAD SIGN STRUCTURE – BRIDGE MOUNTED.....	123
COARSE SAND PLACEMENT .....	123
ABANDON EXISTING CULVERT .....	124
CONCRETE BARRIER BASE (SPECIAL).....	124
CONCRETE BARRIER, VERTICAL FACE (SPECIAL) .....	125
EMBANKMENT TESTING FOR MSE WALL CONSTRUCTION .....	125
EXPRESSWAY SWEEPING CYCLE .....	126
FENCE REMOVAL.....	127
GAS/OIL PIPELINE PROTECTION.....	128
FILLING EXISTING RUMBLE STRIP .....	150
MAINTAINING ITS DURING CONSTRUCTION.....	151

MOWING (SPECIAL).....	153
MOWING CYCLES .....	154
PROTECTION OF EXISTING TREES.....	155
PRUNING FOR SAFETY AND EQUIPMENT CLEARANCE .....	157
REMOVAL AND DISPOSAL OF REGULATED SUBSTANCES (PROJECT SPECIFIC) .....	157
STABILIZED CONSTRUCTION ENTRANCE.....	162
TREE REMOVAL DATE RESTRICTION .....	163
TREE REMOVAL, ACRES (SPECIAL) .....	163
WEED CONTROL, BASAL TREATMENT .....	166
WEED CONTROL, NATIVE LANDSCAPE ENHANCEMENT .....	168
STORM WATER POLLUTION PREVENTION PLAN .....	170
U.S. ARMY CORPS OF ENGINEERS REGIONAL PERMIT.....	184
HIGH LOAD MULTI-ROTATIONAL BEARINGS .....	197
ERECTION OF CURVED STEEL STRUCTURES .....	203
DIAMOND GRINDING AND SURFACE TESTING BRIDGE SECTIONS.....	204
SLIPFORM PARAPET .....	209
BRIDGE DECK CONSTRUCTION .....	214
BRIDGE DECK GROOVING (LONGITUDINAL) .....	215
METALLIZING OF STRUCTURAL STEEL .....	216
DRILLED SHAFTS.....	232
CONSTRUCTION REQUIREMENTS.....	235
PREFORMED PAVEMENT JOINT SEAL .....	243
BAR SPLICERS, HEADED REINFORCEMENT .....	250
AGGREGATE SUBGRADE IMPROVEMENT (BDE).....	251
BITUMINOUS MATERIALS COST ADJUSTMENTS (BDE).....	253
CEMENT, TYPE IL (BDE) .....	255
COMPENSABLE DELAY COSTS (BDE).....	255
CONSTRUCTION AIR QUALITY – DIESEL RETROFIT (BDE) .....	259
DISADVANTAGED BUSINESS ENTERPRISE PARTICIPATION (BDE).....	261
FUEL COST ADJUSTMENT (BDE) .....	270
HOT-MIX ASPHALT (BDE) .....	273
HOT-MIX ASPHALT – LONGITUDINAL JOINT SEALANT (BDE).....	273
MATERIAL TRANSFER DEVICE (BDE).....	275
MECHANICALLY STABILIZED EARTH RETAINING WALLS (BDE) .....	277
PERFORMANCE GRADED ASPHALT BINDER (BDE) .....	277
PORTLAND CEMENT CONCRETE (BDE) .....	282
PREFORMED PLASTIC PAVEMENT MARKING (BDE).....	283

REMOVAL AND DISPOSAL OF REGULATED SUBSTANCES (BDE).....	284
SEEDING (BDE) .....	285
SHORT TERM AND TEMPORARY PAVEMENT MARKINGS (BDE).....	290
SOURCE OF SUPPLY AND QUALITY REQUIREMENTS (BDE).....	294
STEEL COST ADJUSTMENT (BDE).....	294
SUBCONTRACTOR AND DBE PAYMENT REPORTING (BDE) .....	298
SUBCONTRACTOR MOBILIZATION PAYMENTS (BDE).....	298
SUBMISSION OF PAYROLL RECORDS (BDE).....	299
SURFACE TESTING OF PAVEMENTS – IRI (BDE) .....	300
TRAFFIC SPOTTERS (BDE).....	306
TRAINING SPECIAL PROVISIONS (BDE).....	308
IDOT TRAINING PROGRAM GRADUATE ON-THE-JOB TRAINING SPECIAL PROVISION .....	311
VEHICLE AND EQUIPMENT WARNING LIGHTS (BDE).....	313
WEEKLY DBE TRUCKING REPORTS (BDE).....	313
WOOD SIGN SUPPORT (BDE).....	313
WORK ZONE TRAFFIC CONTROL DEVICES (BDE) .....	314
MENTOR-PROTÉGÉ PROGRAM .....	316
PROJECT LABOR AGREEMENT.....	317
WORKFORCE SUPPORTIVE SERVICES.....	336

## STATE OF ILLINOIS

---

### SPECIAL PROVISIONS

The following Special Provisions supplement the "Standard Specifications for Road and Bridge Construction," adopted January 1 2022, the latest edition of the "Manual on Uniform Traffic Control Devices for Streets and Highways," and the "Manual of Test Procedures for Materials" in effect on the date of invitation for bids, and the Supplemental Specifications and Recurring Special Provisions indicated on the Check Sheet included herein which apply to and govern the construction of FAI Route 80 (I-80), Project NHHP-HISX(002), Section FAI 80 21 STRUCTURE 5, Will County, Contract No. 62R26 and in case of conflict with any part or parts of said Specifications, the said Special Provisions shall take precedence and shall govern.

FAI Route 80 (I-80)  
Project NHHP-HISX(002)  
Section FAI 80 21 STRUCTURE 5  
Will County  
Contract No. 62R26

### LOCATION OF PROJECT

The project is located at the FAI Route 80 and FAI Route 55 Interchange in the City of Joliet and Village of Shorewood, Illinois and the Township of Troy in the County of Will. The gross length of the project is 3,110 feet (0.589 miles) and the net length of the project is 2,919 feet (0.553 miles).

### DESCRIPTION OF PROJECT

This project consists of the partial reconstruction of entrance and exit ramps at the I-80 and I-55 interchange. The work also includes the construction of a new directional ramp for southbound I-55 to eastbound I-80 and flyover bridge crossing over Interstate 55 (S.N. 099-8330). The work also includes reconstruction of Mound Road/E. Frontage Road, construction of new retaining walls and drainage improvements within the reconstruction limits. Related work proposed in this contract includes grading, pavement marking, signage, erosion control, landscaping, and replacement of the existing access control fencing.

## SOILS INFORMATION

Soil boring logs and generalized soil profiles are shown in the Plans for SN 099-8330.

The reports below are available for inspection at IDOT District 1, 201 W. Center Court, Schaumburg, Illinois.

Roadway Geotechnical Report  
Interstate 80 and Interstate 55  
Interchange Improvements  
Will County, Illinois  
Prepared by Wang Engineering, Inc. a Terracon Company  
Original: January 18, 2024  
Revised Report: May 6, 2024

Structure Geotechnical Report  
Interstate 55 Ramp AA Bridge  
Over Interstate 55  
PR SN 099-8330, Contract 62R26  
Will County, Illinois  
Prepared by Wang Engineering, Inc.  
Original: February 27, 2023  
Revised Report: March 21, 2024

Structure Geotechnical Report  
I-80 Reconstruction from Ridge Road  
To Houbolt Road  
I-55 Ramp AA Retaining Wall  
SN 099-W1001  
Will County, Illinois  
Prepared by Wang Engineering, Inc.  
Original: February 23, 2024  
Revised Report: March 1, 2024

Structure Geotechnical Report  
I-80 Reconstruction from Ridge Road  
To Houbolt Road  
I-55 Ramp AA Retaining Wall  
SN 099-W1002  
Will County, Illinois  
Prepared by Wang Engineering, Inc.  
Original: October 19, 2023  
Revised Report: NA

Structure Geotechnical Report  
I-80 Reconstruction from Ridge Road  
To Houbolt Road  
I-55 Ramp AA Retaining Wall  
SN 099-W1003  
Will County, Illinois  
Prepared by Wang Engineering, Inc.  
Original: November 22, 2023  
Revised Report: April 4, 2024

## **CONTRACTOR COOPERATION**

The Contractor's attention is directed to the fact that other separate contracts may be under construction during the duration of this Contract. It is anticipated that this contract will be constructed concurrently with other roadway projects in the same area. The projects that may be under contract concurrent with this project are as follows:

***IDOT Contract No. 62R28 (Interstate 80 from E/O River Road to W/O Houbolt Road: Mainline Pavement Reconstruction and Bridge Reconstruction)***

***IDOT Contract No. 62R27 (Interstate 80 from W/O Houbolt Road to Joliet Junction Trail: Mainline Pavement Reconstruction and Bridge Reconstruction)***

***IDOT Contract No. 62R19 (Intelligent Transportation Systems (ITS) Integration)***

The Contractor will be governed by Article 105.08 of the Standard Specifications. No additional compensation will be allowed for delays or inconveniences resulting from activities of other contractors. The Contractor shall schedule his work in order to minimize any conflicts that may arise between contracts as specified in Article 105.08 of the Standard Specifications.

The Contractor may be required to attend a weekly coordination meeting at a time and location to be determined by the Department.

The Contractor will coordinate proposed project start dates and sequence of construction with the Engineer and other Contractors to present an effective and timely schedule for successful completion of the project.

The cooperation between work under this contract, Contracts 62R28 and 62R27 is essential due to the adjacent limits of construction and shared maintenance of traffic responsibilities along I-80. All traffic staging configurations and changes to staging along I-80 and associated ramps shall be coordinated with the contractor performing work under Contracts 62R28 and 62R27.

## COORDINATION WITH ADJACENT AND/OR OVERLAPPING CONTRACTS

This contract abuts and/or overlaps with other concurrent contracts listed below. Each contract includes work items requiring close coordination between the various Contractors regarding the sequence and timing of execution of work items. This contract also includes critical work items that affect the future staging of traffic and completion dates of other contracts. These critical items along with completion dates are listed after each contract.

**Contract No. 62R28 – Interstate 80 from E/O River Road to W/O Houbolt Road: Mainline Pavement Reconstruction and Bridge Reconstruction** The Contractor shall coordinate with the Department and make MOT and construction activity modifications to accommodate the planned work. The cost for coordination, modifications required to MOT and construction activities, and installation and removal lane closures shall be included in the cost of Traffic Control and Protection (Expressways).

- Completion Date For Pre-Stage Work – November 15, 2024
- Completion Date For Stage 1 Work – November 14, 2025
- Completion Date – October 30, 2026.

**Contract No. 62R27 – Interstate 80 from W/O Houbolt Road to Joliet Junction Trail: Mainline Pavement Reconstruction and Bridge Reconstruction.** The Contractor shall coordinate with the Department and make MOT and construction activity modifications to accommodate the planned work. The cost for coordination, modifications required to MOT and construction activities, and installation and removal lane closures shall be included in the cost of Traffic Control and Protection (Expressways).

- Completion Date For Pre-Stage Work – November 15, 2024
- Completion Date For Stage 1 Work – November 14, 2025
- Completion Date – October 30, 2026.

Contract 62R27 will furnish, install, maintain, relocate and remove a Smart Traffic Monitoring System for the I-80 corridor, including within these Contract limits. This system will include:

- Vehicle Detection Devices at approx. ½-mile spacing
- Portable Video Tower Stations at approx. ½-mile spacing
- Portable Changeable Message Signs (PCMS) at approx. 1-mile spacing and at existing Dynamic Message Sign (DMS) locations



The devices will be located in the approaches to the Work Zones and within the Work Areas for the entire contract limits for the duration of the Contract. The existing DMS must remain in place and functional until the PCMS are installed and functional at the existing DMS locations.

The Contractor shall coordinate and provide access to the 62R27 Contractor for the initial placement, and subsequent relocations, maintenance and removal of the devices. The Contractor shall plan work activities to limit the number of times a device needs to be relocated to twice per main stage (Stages 1 & 2) and once between stages for a total of five (5) relocations per device. The Contractor shall provide written notification to the 62R27 Contractor a minimum of 14 calendar days prior to a device needing to be relocated.

The Contractor may have to temporarily widen embankments with sandbags or other temporary material to properly install the smart work zone devices on a level surface. The costs associated with temporarily widening embankments and restoring the embankment upon completion shall be according to Article 109.04 of the Standard Specifications

Any damage to the devices caused by the Contractor shall be repaired to the satisfaction of the Engineer.

#### **Contract No. 62R19 - Intelligent Transportation Systems (ITS) Integration**

The ITS Integration Contract will furnish and install ITS wiring and devices within the Contract limits. The Contractor shall coordinate and provide access to the Work Areas to the ITS Integration Contractor to complete their work. The Contractor shall maintain protected Work Areas until the ITS Integration work is complete and accepted.

- Completion date: October 31, 2027 (Estimated)

## **COOPERATION BETWEEN CONTRACTORS**

The following should be added to Article 105.08:

The Department reserves the right to have work performed by other contractors and by Department forces and to permit public utility companies and others to perform work during the progress and within the limits of or adjacent to the work. The Contractor shall conduct its work in a manner and shall cooperate with such other parties to cause as little interference as possible with such other work and as the Department may also direct. If there is a difference of opinion as to the respective rights of the Contractor and others doing work within the limits of or adjacent to the work, the Engineer will decide the order and coordination of the work. The Engineer's decision shall be final and binding on the Contractor. The Contractor shall make no claims against the Department for additional compensation due to delays or other conditions created by the operations of such other parties.

Coordination with Other Contractors. The Contractor is advised that certain operations will involve coordination with Department personnel and Contractors currently performing work on or adjacent to this project for the Department and other agencies. The Contractor shall cooperate to the fullest extent with the Department and the Contractors working on adjacent projects in compliance with Articles 105.07 and 105.08 of these Specifications.

The Contractor shall submit to the Resident Engineer a daily work schedule for the purpose of coordinating the Contractor's activities for the next working day. The daily work schedule must be submitted by 3:00 p.m. the day prior. This schedule is necessary and shall be used by the Engineer to schedule inspections, material testing and checking of layout as part of the following day's work. Failure to submit a schedule may result in uninspected work and therefore considered unacceptable.

The daily schedule shall include the Contractor's or Sub-Contractor's planned work for that day including the location, description, scheduled work hours and pay items of work to be performed. The schedule shall also include any material testing requests, layout check requests and all traffic control measures to be implemented for that day's work.

The Department and the Engineer shall be notified in writing by the Contractor at least 48 hours prior to the start of any operation requiring cooperating with others. All other agencies, unless otherwise noted, will be notified in writing by the Contractor ten (10) days prior to the start of any such operation. The Contractor shall make no claims against the Department for additional compensation due to delays or other conditions created by the operations of such other parties.

## COOPERATION WITH UTILITIES

The Contractor is responsible for verifying the nature and status of all utility relocation work before preparing the Baseline Schedule. The Contractor shall take appropriate measures to ensure that construction operations do not interfere with utility facilities and relocation work. The Baseline Schedule shall reflect construction sequencing, which coordinates with all utility relocation work. The Contractor shall be required to adjust the order of its work from time to time, to coordinate with utility relocation work, and shall prepare revised Baseline Schedule(s) as directed by the Engineer.

## PROGRESS SCHEDULE

**Description.** Time is of the essence in this Contract. It may be necessary for the Contractor to work longer hours, use additional crews, and work during weekends to complete the work within the required time limit. The Contractor shall submit a Critical Path Method (CPM) Progress Schedule as described below for the Engineer's approval before the work can be started.

The Contractor will not be allowed any compensation for working longer hours or using extra shifts; and working on weekends or during Holidays; working during winter months, etc. to meet the specified Completion Date.

This work shall consist of preparing, revising, and updating a detailed progress schedule based upon the Critical Path Method (CPM). This work shall also consist of performing time impact analysis of the progress schedule based upon the various revisions and updates as they occur.

**Requirements.** The software shall produce an electronic progress schedule for submission to the department that is 100% compatible with Primavera P6.

**Format.** The electronic schedule format shall contain the following:

- a. Project Name: (Optional).
- b. Template: Construction.
- c. Type: Provide Primavera P6.xer native file format and a pdf file during each submittal.
- d. Planning Unit: Days (calendar working).
- e. Number/Version: Original or updated number.
- f. Start Date: Not later than ten days after execution of the contract.
- g. Must Finish Date: Completion date for completion date contracts.
- h. Project Title: Contract number.
- i. Company Name: Contractor's name.

**Calendars.**

- a. Completion Date Contracts. The base calendar shall show the proposed working days of the week and the proposed number of work hours per day.

**Schedule Development.** The detailed schedule shall incorporate the entire contract time. The minimum number of activities shown on the schedule shall represent the work incorporating the pay items whose aggregate contract value constitutes 80 percent of the total contract value. These pay items shall be determined by starting with the pay item with the largest individual contract value and adding subsequent pay item contract values in descending order until 80 percent of the contract value has been attained. Any additional activities required to maintain the continuity of the schedule logic shall also be shown.

No schedule or updates containing negative total float will be accepted.

The following shall be depicted in the schedule for each activity:

- a. Activity Identification (ID) Numbers. The Contract shall utilize numerical designations to identify each activity. Numbering of activities shall be in increments of not less than ten digits.
- b. A description of the work represented by the activity (maximum forty-five characters). The use of descriptions referring to a percentage of a multi-element item (i.e., construct deck 50%) shall not be used. Separate activities shall be included to represent different elements of multi-element items (i.e., forms, reinforcing, concrete, etc.). Multiple activities with the same work description shall include a location as part of the description.
- c. Proposed activity duration shall be shown in whole days. The Contractor shall provide production rates to justify the activity duration. Schedule duration shall be contiguous and not interruptible.
- d. Duration of all major activities included in the Contractor's Work.
- e. Identification of all precedent relationships between the Contractor's activities, as well as those of subcontractors, utilities, and the Department, based on a thorough review of the Contract Documents, showing the interface between separate contractor's work.
- f. Estimated crew sizes, equipment, production rates, and similar data used to arrive at adequate durations and sequences.
- g. Activity descriptions and durations for preparation and processing of shop drawings; preparation and review of required coordination drawings; conducting any required testing or inspections; obtaining product data and samples; and fabrication, delivery and installation/erection of products, materials and equipment.

The schedule shall indicate the sequence and interdependence of activities required for the prosecution of the work. The schedule logic shall not be violated.

Activities should be broken down such that each activity encompasses a single operation or tightly integrated operations in a single, contiguous, and continuous area of the project, with no activity exceeding \$200,000 without the consent of the Engineer.

Total Float shall be calculated as finish float. The schedule shall be calculated using retained logic. The Contractor shall not sequester float by calendar manipulations or extended duration. Float is not for the exclusive use or benefit of either the Department or the Contractor.

A Schedule Narrative that describes the critical path(s) of the project, outlines the Contractor's approach to complete the work, defines the project calendars and identifies critical resources. Updated Schedule Narratives will also be required for each monthly update and Revised Baseline Schedules.

Activity description shall be descriptive to identify its intent, including location of work. Activity Durations for construction activities in excess of 30 calendar days will not be allowed.

The contractor shall provide additional schedule tasks as requested to assist the Engineer with communicating how its work will impact local communities and traffic.

The Contractor is responsible for verifying the nature and status of all utility relocation work before preparing the Baseline Schedule. The Contractor shall take appropriate measures to ensure that construction operations do not interfere with utility facilities and relocation work. The Baseline Schedule shall reflect construction sequencing, which coordinates with all utility relocation work. The Contractor shall be required to adjust the order of its work from time to time, to coordinate same with utility relocation work, and shall prepare revised Baseline Schedule(s) in compliance their addition to that directed by the Engineer.

**Tabular Reports.**

- a. The following tabular reports will be required with each schedule submission:
  - 1. Classic Gantt
  - 2. Pert with Time Scale
- b. The heading of each tabular report shall include, but not be limited to, the project name, contract number, Contractor name, report date, data date, report title and page number.

- c. Each of the tabular reports shall also contain the following minimum information for each activity.
  1. Activity ID
  2. Activity Description
  3. Original Duration (calendar day/working day)
  4. Remaining Duration (calendar day/working day)
  5. Activity Description
  6. Early Start Date
  7. Late Start Date
  8. Early Finish Date
  9. Late Finish Date
  10. Percent Complete
  11. Total Float
  12. Calendar ID
  13. Work performed by DBE Subcontractors and Trainees shall be shown in the Gantt Report.
- d. Reports shall be printed in color on 11 in. x 17 in. (minimum) size sheets. The Classic Gantt shall show all columns, bars, column headings at the top, time scale at the top and shall show relationships.

**Submission Requirements.** The initial schedule shall be submitted prior to starting work but no later than five calendar days after execution of the contract. Updated schedules shall be submitted according to Article 108.02 except that monthly updates will be required according to the following Monthly Schedule Update section.

**Updating.**

- a. The Contractor shall not make any changes to the original duration, activity relationships, constraints, costs, add or delete activities, or alter the schedule's logic when updating the schedule.
- b. The originally approved baseline CPM schedule shall only be changed based on a Change Order that extends the Contract duration. All updates will be plotted against the "Baseline Schedule or approved Revised Schedule." If the Contractor believes any such changes result in an overall increase in the contract time, the Contractor will immediately submit a request for extension of time along with the changed progress schedule and a detailed justification for the time extension request in accordance with Article 108.08.

- c. The updated information will include the original schedule detail and the following additional information:
  - 1. Actual start dates
  - 2. Actual finish dates
  - 3. Activity percent completion
  - 4. Remaining duration of activities in progress
  - 5. Identified or highlighted critical activities
- d. The Contractor shall submit scheduling documents in the same formats and number as indicated in this section.
- e. The Engineer shall withhold progress payments if the Contractor does not submit scheduled updates as required.
- f. Upon receipt of the CPM schedule update, the Engineer will review the schedule for conformance with the Contract Documents and degree of detail. The Engineer, within fourteen (14) Days after receipt of the Updated CPM Schedule and supporting documents, will approve or reject it with written comments. If the Updated CPM schedule is rejected, the Contractor must submit a Revised Updated CPM Schedule within seven (7) Days after the date of rejection.
- g. The updated progress schedule must accurately represent the Project's status.

**Contractor Changes to the Schedule.** The Contractor shall comply with the following requirements regarding proposed changes to the approved baseline CPM schedule:

- a. If the Contractor proposes to make any changes in the approved baseline CPM schedule, the Contractor shall notify the Engineer in writing, stating the reasons for the change, identifying each changed activity (including duration and interrelationships between activities), and providing a diskette of the proposed changed schedule. Every effort must be made by the Contractor to retain the original Activity ID numbers.
- b. The Engineer has the authority to approve or disapprove the proposed change in the baseline CPM schedule and shall do so in writing within ten (10) Days after receipt to the Contractor's submission.
- c. If the Engineer approves the change in the baseline. All monthly updates will be plotted against the new "Revised Schedule."
- d. If the Engineer approves a portion of the change to the baseline CPM schedule, the Contractor shall submit a revised CPM schedule incorporating such change(s) within ten (10) Days after approval along with a written description of the change(s) to the schedule.

### **Recovery Schedule.**

- a. The Contractor shall maintain an adequate work force and the necessary materials, supplies and equipment to meet the current approved baseline CPM schedule. If the Contractor, in the judgment of the Engineer, is failing to meet the approved CPM schedule including any Contract milestones, the Contractor shall submit a recovery schedule.
- b. The recovery schedule shall set forth a plan to eliminate the schedule slippage (negative float). The plan must be specific to show the methods to achieve the recovery of time, i.e., increasing manpower, working overtime, weekend work, employing multiple shifts. All costs associated with implementing the recovery schedule shall be borne by the Contractor.
- c. Upon receipt of the CPM recovery schedule, the Engineer will review the schedule for conformance with the Contract Documents and degree of detail. The Engineer will approve the schedule or reject it with written comments within fourteen (14) Days of receipt of the recovery schedule and supporting documents. If the detailed CPM recovery schedule is rejected, the Contractor must submit a revised CPM recovery schedule within seven (7) Days of the date of rejection.

**Revised Schedule.** The Engineer may direct the Contractor to revise the approved CPM schedule. Reasons for such direction may include, but are limited to, the following: (1) changes in the Work, (2) re-phasing of the Project or any phase, (3) a change in the duration of the Project or phase, and (4) acceleration of the Project or phase.

- a. The Engineer will direct the Contractor to provide a revised CPM schedule in writing.
- b. The Contractor will provide the revised CPM schedule within ten (10) Days of receipt of the Engineer's written direction.
- c. The Engineer has the authority, in its sole discretion, to approve or reject the revised CPM schedule and will do so in writing within ten (10) Days after receipt of the Contractor's submission. If the Engineer approves the revised schedule, such schedule will be designated the new "Target Schedule."

The schedule shall be submitted in the Sorted by Activity Layout (SORT4). The activities on the schedule shall be plotted using early start, late start, early finish, late finish, and total finish.

For every schedule submission, the Contractor shall submit to the Engineer, four USB thumb drives of all schedule data. Included on the thumb drives shall be all the tabular and graphic reports, network diagrams and bar chart data. In addition, four plots of the USB thumb drives will be approved initial or revised progress schedule for the contract. The approval will be documented by the Engineer on a corresponding plot of the schedule and returned to the Contractor.

Four copies of each schedule submission shall be printed in color on 11 in. x 17 in. (minimum) size sheets showing all columns, bars, column headings at the top, time scale at the top and showing relationships.



The schedule shall indicate the critical path to contract completion. Only one controlling item shall be designated at any point in time on the schedule.

Acceptance or approval of any progress schedule by the Engineer shall not be construed to imply approval of any method of construction, sequence of construction, any implied or stated rate of production. Acceptance will not function as a waiver of the obligation of the Contractor to complete the work in accordance with the contract proposal, Plans and Specifications, modify any rights or obligations of the Department as set forth in the contract, nor imply any obligation of a third party. Acceptance shall not be construed to modify or amend the contract or the time limit(s) therein. Acceptance shall not relieve the Contractor of the responsibility for the accuracy of any of the information included on the schedule. Failure of the Contractor to include in the schedule any element of work required for the performance of the contract, any sequence of work required by the contract, or any known or anticipated condition affecting the work shall not excuse the Contractor from completing all work required within the time limit(s) specified in the contract notwithstanding acceptance of the schedule by the Engineer.

**Monthly Schedule Update (MSU).** After acceptance of the Contractor's Baseline Schedule, the contractor shall monitor progress of the work and update the schedule 30 Calendar Days from the date of acceptance and every 30 Calendar Days thereafter no later than the 10th calendar day of each month thereafter to reflect actual progress. Completed work must not be removed from the MSU. The MSU will be used as the basis for reviewing the Contractor's monthly progress. The purpose of the MSU is to report progress in accordance with the latest accepted schedule and is not to be used to revise the schedule logic, resources, durations or constraints. If the Engineer is going to reject an MSU, the Engineer will call a meeting with the Contractor and CM in order to discuss the deficiencies in an attempt to more quickly reach resolution and obtain an acceptable MSU.

**Basis of Payment.** This work will not be paid for separately but shall be considered as included in the costs of the various items of work in the contract.

## WORK RESTRICTIONS

Prior to the actual beginning and completion of the various stages of construction and traffic control and protection, the Contractor will be required to provide lane closures and barricade systems, for preparation work such as pavement marking removal, temporary lane marking, placing temporary concrete barrier, relocating existing guardrail, etc. These lane closures and barricade systems, including barricades, drums, cones, lights, signs, flaggers etc. shall be provided in accordance with details in the Plans and these Special Provisions and as approved by the Engineer.

For the purpose of the proposed Progress Schedule required by Article 108.02 of the Standard Specifications for Road and Bridge Construction and other parts of the specifications, the contractor shall not implement roadway work prior to **April 1, 2025**. The Contractor shall identify work that can be completed prior to roadway or ramp Maintenance of Traffic configuration and submit a written work plan to the Engineer for review and approval. The Contractor shall perform this work upon receipt of written approval by the Engineer. No adjustment to the contract completion date or interim completion date will be made should the contractor perform other work prior to April 1, 2025. No extension of the contract completion date or interim completion date will be made should the Contractor elect to not perform other work prior to April 1, 2025.

The cost of this work will not be paid for separately but shall be considered included in the contract lump sum price for TRAFFIC CONTROL AND PROTECTION (EXPRESSWAYS).

The Contractor shall submit to the Department two (2) weeks ahead of time, in writing, the starting date for each of the extended ramp and/or lane closures. Approval from the Department is required prior to closing the ramp and/or lanes. Should the Contractor fail to complete the work and reopen the ramp to traffic within the allowable time limit, the Contractor shall be liable to the Department for liquidated damages as noted below.

Prior to and after stage construction, temporary lane closures on Interstate 80, Interstate 55 and associated ramps will only be permitted at night during the allowable hours as listed in the Special Provision KEEPING THE EXPRESSWAY OPEN TO TRAFFIC. These hours also apply to temporary closures of the ramps, which are shown as open on the Maintenance of Traffic plan sheets.

For all lane and ramp closures, the Contractor shall furnish and install signage per District Detail TC-08, as directed by the Engineer.

The Contractor shall submit to the Department two (2) weeks ahead of time, in writing, the starting date for each of the extended ramp and/or lane closures. Approval from the Department is required prior to closing the ramp and/or lanes. Should the Contractor fail to complete the work and reopen the ramp to traffic within the allowable time limit, the Contractor shall be liable to the Department for liquidated damages as noted under FAILURE TO OPEN TRAFFIC LANES TO TRAFFIC

## WORK RESTRICTIONS

### Restriction No. 1: MAINLINE I-55

- Full closures of I-55 will not be allowed except as noted in KEEPING THE EXPRESSWAY OPEN TO TRAFFIC.
- Construction sequencing for the Ramp AA bridge over Interstate 55 is required to align with the work defined in Contract 62R28 for the construction of I-80 over I-55 structures (S.N. 099-8316 (EB) & 099-8317 (WB)). The Contractor shall schedule construction of the center pier of the Ramp AA over I-55 bridge (S.N. 099-8330) so that traffic control does not conflict or otherwise interfere with the traffic control implemented for the Interstate 80 over Interstate 55 bridge work performed in Contract 62R28.

### Restriction No. 2: RAMP AA ROADWAY EMBANKMENT (STA. 17+00 TO STA. 31+09.56)

- Ramp AA grading work to complete the roadway embankment between Sta. 17+00 and Sta. 31+09.56 shall be completed by November 15, 2025.

### Restriction No. 3: RAMP D (SB I-55 TO WB I-80)

- Construction sequencing for Ramp D (SB I-55 to WB I-80) is required to align with the work defined in Contract 62R28. The Contractor shall schedule construction of the ramp so that traffic control does not conflict or otherwise interfere with the traffic control implemented in Contract 62R28.

The Special Provision for COOPERATION BETWEEN CONTRACTORS shall apply to this special provision.

The cost of this work will not be paid for separately but shall be considered included in the contract lump sum price for TRAFFIC CONTROL AND PROTECTION (EXPRESSWAYS).

## **WINTER/LOW AIR TEMPERATURE WORK**

Winter work is anticipated as part of this contract.

No adjustments will be made in the contract unit prices for any concrete if winter or low air temperature work is necessary to meet the required completion dates specified in the contract.

## **MAINTENANCE OF ROADWAYS (D1)**

Effective: September 30, 1985

Revised: November 1, 1996

Beginning on the date that work begins on this project, the Contractor shall assume responsibility for normal maintenance of all existing roadways within the limits of the improvement. This normal maintenance shall include all repair work deemed necessary by the Engineer, but shall not include snow removal operations. Traffic control and protection for maintenance of roadways will be provided by the Contractor as required by the Engineer.

If items of work have not been provided in the contract, or otherwise specified for payment, such items, including the accompanying traffic control and protection required by the Engineer, will be paid for in accordance with Article 109.04 of the Standard Specifications.

**STATUS OF UTILITIES (D1)**

Effective: June 1, 2016

Revised: January 1, 2020

Utility companies and/or municipal owners located within the construction limits of this project have provided the following information regarding their facilities and the proposed improvements. The tables below contain a description of specific conflicts to be resolved and/or facilities which will require some action on the part of the Department's contractor to proceed with work. Each table entry includes an identification of the action necessary and, if applicable, the estimated duration required for the resolution.

**UTILITIES TO BE ADJUSTED**

Conflicts noted below have been identified by following the suggested staging plan included in the contract. The company has been notified of all conflicts and will be required to obtain the necessary permits to complete their work; in some instances, resolution will be a function of the construction staging. The responsible agency must relocate, or complete new installations as noted below; this work has been deemed necessary to be complete for the Department's contractor to then work in the stage under which the item has been listed.

**Pre-Stage**

No identified conflicts to be resolved

**Stages 1 and 2**

<b>STAGE / LOCATION</b>	<b>TYPE</b>	<b>DESCRIPTION</b>	<b>RESPONSIBLE AGENCY</b>	<b>DURATION OF TIME</b>
NB I-55 Auxiliary Lane and Ramp B  Ramp B STA. 993+51.2 RT to South Project Limit	Fiber Optic	Buried 2" Conduit	Century Link (Lumen)	Unknown
E. Frontage Road  STA. 13+24.3 LT/RT to South Project Limit	Telephone	Unknown	AT&T	Unknown
NB I-55 Auxiliary Lane and Ramp B  Ramp B Crossing at STA. 1001+89.5	Fiber Optic	Buried 2" Conduit	Century Link (Lumen)	Unknown

<p>NB I-55 Auxiliary Lane and Ramp B  Ramp B Crossing at STA.1003+76.6</p>	<p>Fiber Optic</p>	<p>Buried 2" Conduit  (includes wires with equipment with charges located on existing line pole at: PR Ramp A Sta. 73+03, 38' RT; west of I-55)</p>	<p>ComEd</p>	<p>Unknown</p>
<p>NB I-55 Auxiliary Lane, Ramp B, E Frontage Road  Ramp B Crossing at STA. 1004+12.6  E Frontage Road STA. 13+61.5 LT to STA 35+95.9 RT</p>	<p>Fiber Optic</p>	<p>Buried 1.5" Conduit</p>	<p>METRO</p>	<p>Unknown</p>
<p>E. Frontage Road  E. Frontage Road STA. 16+77.1 LT to STA. 34+61.9 RT</p>	<p>Electric</p>	<p>Fiber on Pole (aerial service) and Power Poles  Sta. 13+30, 0' RT Sta. 14+18, 0' RT Sta. 15+37, 0' RT Sta. 16+75, 0' RT Sta. 18+20, 6' RT Sta. 19+25, 11' RT Sta. 20+44, 19' RT Sta. 21+84, 29' RT Sta. 23+28, 46' RT Sta. 25+19, 37' RT Sta. 26+97, 10' RT Sta. 28+65, 8' LT Sta. 29+59, 14' LT Sta. 30+91, 3' LT Sta. 32+32, 0' LT Sta. 33+57, 23' LT Sta. 34+63, 16' RT Sta. 36+67, 16' RT</p>	<p>ComEd</p>	<p>60 Days</p>

The following contact information is what was used during the preparation of the plans as provided by the Agency/Company responsible for resolution of the conflict.

<b>Agency/Company Responsible to Resolve Conflict</b>	<b>Name of contact</b>	<b>Phone</b>	<b>E-mail address</b>
AT&T Distribution	Steve Pesola	(630) 573-5703	sp9653@att.com
ComEd	Joseph Milani	(708) 208-9758	Joseph.Milani@ComEd.com
Century Link (Lumen)	Ben Pacocha	(847) 954-8250	ben.pacocha@lumen.com
METRO Fiber	Taylor Rich	(217) 728-9056	trich@metrocomm.com

**UTILITIES TO BE WATCHED AND PROTECTED**

The areas of concern noted below have been identified by following the suggested staging plan included for the contract. The information provided is not a comprehensive list of all remaining utilities, but those which during coordination were identified as ones which might require the Department's contractor to take into consideration when making the determination of the means and methods that would be required to construct the proposed improvement. In some instances, the contractor will be responsible to notify the owner in advance of the work to take place so necessary staffing on the owner's part can be secured.

**All-Stages**

<b>STAGE / LOCATION</b>	<b>TYPE</b>	<b>DESCRIPTION</b>	<b>OWNER</b>
NB I-55 Auxiliary Lane and Ramp B  Ramp B Crossing at STA. 997+98.70 and STA. 998+31.1	Gas	Gas Mains (30" pipeline and 22" pipeline in a 24" RCP casing)  Provide notice of at least seventy-two (72) hours in advance of construction.  IDOT must contact the following TC Energy field representatives:  Name: Chad Klatt Cell: 815-826-0987  TC Energy will arrange for a representative to be on site when work is occurring on or near the	TC Energy

		Right of Way area, or within 25' of the pipelines. After hours call 1-800-447-8066.  Additional requirements are outlined in the Special Provision GAS/OIL PIPELINE PROTECTION.	
NB I-55 Auxiliary Lane and Ramp B  Ramp B Crossing at STA. 999+39.6	Petroleum	24" pipeline in 30" RCP casing  Additional requirements are outlined in the Special Provision GAS/OIL PIPELINE PROTECTION.	Enbridge
SB I-55 Auxiliary Lane and Ramp A  I-55 Crossing at STA. 1076+22.1	Telephone	(2) – 4" PVC Conduits	AT&T
I-55  I-55 Sta. 1012+10	Gas	4" Gas Main	Nicor Gas

The following contact information is what was used during the preparation of the plans as provided by the owner of the facility.

<b>Agency/Company Responsible to Resolve Conflict</b>	<b>Name of contact</b>	<b>Phone</b>	<b>E-mail address</b>
TC Energy	Karen Macejewski	(832) 320-5414	karen_macejewski@tcenergy.com
Enbridge	Shane Young	(346) 732-7291	<a href="mailto:Shane.young@enbridge.com">Shane.young@enbridge.com</a>
AT&T Distribution	Steve Pesola	(630) 573-5703	sp9653@att.com
Nicor Gas	Joe Gaca	708-243-5317	JGaca@southernco.com

The above represents the best information available to the Department and is included for the convenience of the bidder. The days required for conflict resolution should be considered in the bid as this information has also been factored into the timeline identified for the project when setting the completion date. The applicable portions of the Standard Specifications for Road and Bridge Construction shall apply.

Estimated duration of time provided above for the first conflicts identified will begin on the date of the executed contract regardless of the status of the utility relocations. The responsible agencies will be working toward resolving subsequent conflicts in conjunction with contractor activities in the number of days noted.

The estimated relocation duration must be part of the progress schedule submitted by the contractor. A utility kickoff meeting will be scheduled between the Department, the Department's contractor and the utility companies when necessary. The Department's contractor is responsible for contacting J.U.L.I.E. prior to all excavation work.

**PUBLIC CONVENIENCE AND SAFETY (D1)**

Effective: May 1, 2012

Revised: July 15, 2012

Add the following to the end of the fourth paragraph of Article 107.09:

“If the holiday is on a Saturday or Sunday, and is legally observed on a Friday or Monday, the length of Holiday Period for Monday or Friday shall apply.”

Add the following sentence after the Holiday Period table in the fourth paragraph of Article 107.09:

“The Length of Holiday Period for Thanksgiving shall be from 5:00 AM the Wednesday prior to 11:59 PM the Sunday After”

Delete the fifth paragraph of Article 107.09 of the Standard Specifications:

“On weekends, excluding holidays, roadways with Average Daily Traffic of 25,000 or greater, all lanes shall be open to traffic from 3:00 P.M. Friday to midnight Sunday except where structure construction or major rehabilitation makes it impractical.”



**COMPLETION DATE PLUS WORKING DAYS (D1)**

Effective: September 30, 1985

Revised: January 1, 2007

Revise Article 108.05 (b) of the Standard Specifications as follows:

"When a completion date plus working days is specified, the Contractor shall be responsible for completing:

Final Completion Date: All contract items and safely open all roadways to traffic by 11:59 PM on, **October 30, 2026**, except as specified herein. The Contractor will be allowed to complete all clean-up work and punch list items within **10** working days after the completion date for opening the roadway to traffic. Under extenuating circumstances, the Engineer may direct that certain items of work, not affecting the safe opening of the roadway to traffic, may be completed within the working days allowed for clean-up work and punch list items. Temporary lane closures for this work may be allowed at the discretion of the Engineer.

Article 108.09 or the Special Provision for "Failure to Complete the Work on Time", if included in this contract, shall apply to the final completion date, interim completion dates, commencement dates, and the number of working days.

The Special Provision for "Cooperation Between Contractors " shall apply to this special provision."

**FAILURE TO COMPLETE THE WORK ON TIME (D1)**

Effective: September 30, 1985

Revised: January 1, 2007

Should the Contractor fail to complete the work on or before the completion date as specified in the Special Provision for "Completion Date Plus Working Days", or within such extended time as may have been allowed by the Department, the Contractor shall be liable to the Department in the amount of **\$10,000**, not as a penalty but as liquidated damages, for each calendar day or a portion thereof of overrun in the contract time or such extended time as may have been allowed.

In fixing the damages as set out herein, the desire is to establish a certain mode of calculation for the work since the Department's actual loss, in the event of delay, cannot be predetermined, would be difficult of ascertainment, and a matter of argument and unprofitable litigation. This said mode is an equitable rule for measurement of the Department's actual loss and fairly takes into account the loss of use of the roadway if the project is delayed in completion. The Department shall not be required to provide any actual loss in order to recover these liquidated damages provided herein, as said damages are very difficult to ascertain. Furthermore, no provision of this clause shall be construed as a penalty, as such is not the intention of the parties.

A calendar day is every day shown on the calendar and starts at 12:00 midnight and ends at the following 12:00 midnight, twenty-four hours later.

**EMBANKMENT I (D1)**

Effective: March 1, 2011

Revised: November 1, 2013

Description. This work shall be according to Section 205 of the Standard Specifications except for the following.

Material. All material shall be approved by the District Geotechnical Engineer. The proposed material must meet the following requirements.

- a) The laboratory Standard Dry Density shall be a minimum of 90 lb/cu ft (1450 kg/cu m) when determined according to AASHTO T 99 (Method C).
- b) The organic content shall be less than ten percent determined according to AASHTO T 194 (Wet Combustion).
- c) Soils which demonstrate the following properties shall be restricted to the interior of the embankment and shall be covered on both the sides and top of the embankment by a minimum of 3 ft (900 mm) of soil not considered detrimental in terms of erosion potential or excess volume change.
  - 1) A grain size distribution with less than 35 percent passing the number 75 um (#200) sieve.
  - 2) A plasticity index (PI) of less than 12.
  - 3) A liquid limit (LL) in excess of 50.
- d) Reclaimed asphalt shall not be used within the ground water table or as a fill if ground water is present.
- e) The RAP used shall be according to the current Bureau of Materials and Physical Research Policy Memorandum, "Reclaimed Asphalt Pavement (RAP) for Aggregate Applications". Gradation deleterious count shall not exceed 10% of total RAP and 5% of other by total weight.

**CONSTRUCTION REQUIREMENTS**

Samples. Embankment material shall be sampled, tested, and approved before use. The contractor shall identify embankment sources, and provide equipment as the Engineer requires, for the collection of samples from those sources. Samples will be furnished to the Geotechnical Engineer a minimum of three weeks prior to use in order that laboratory tests for approval and compaction can be performed. Embankment material placement cannot begin until tests are completed and approval given.

Placing Material. In addition to Article 202.03, broken concrete, reclaimed asphalt with no expansive aggregate, or uncontaminated dirt and sand generated from construction or demolition activities shall be placed in 6 inches (150 mm) lifts and disked with the underlying lift until a uniform homogenous material is formed. This process also applies to the overlaying lifts. The disk must have a minimum blade diameter of 24 inches (600 mm).

When embankments are to be constructed on hillsides or existing slopes that are steeper than 3H:1V, steps shall be keyed into the existing slope by stepping and benching as shown in the plans or as directed by the engineer.

Compaction. Soils classification for moisture content control will be determined by the Soils Inspector using visual field examination techniques and the IDH Textural Classification Chart.

When tested for density in place each lift shall have a maximum moisture content as follows.

- a) A maximum of 110 percent of the optimum moisture for all forms of clay soils.
- b) A maximum of 105 percent of the optimum moisture for all forms of clay loam soils.

Stability. The requirement for embankment stability in Article 205.04 will be measured with a Dynamic Cone Penetrometer (DCP) according to the test method in the IDOT Geotechnical Manual. The penetration rate must be equal or less than 1.5 inches (38 mm) per blow.

Basis of Payment. This work will not be paid separately but will be considered as included in the various items of excavation.

## **RECLAIMED ASPHALT PAVEMENT FOR NON-POROUS EMBANKMENT AND BACKFILL (D1)**

Effective: April 1, 2001

Revised: January 1, 2007

Add the following sentence to Article 1004.05 (a) of the Standard Specifications:

"Reclaimed Asphalt Pavement (RAP) may be used as aggregate in Non-porous Granular Embankment and Backfill. The RAP material shall be reclaimed asphalt pavement material resulting from the cold milling or crushing of an existing hot-mix bituminous concrete pavement structure, including shoulders. RAP containing contaminants such as earth, brick, concrete, sheet asphalt, sand, or other materials identified by the Department will be unacceptable until the contaminants are thoroughly removed.

Add the following sentence to Article 1004.05 (c)(2) of the Standard Specifications:

"One hundred percent of the RAP when used shall pass the 3 inch (75 mm) sieve. The RAP shall be well graded from coarse to fine. RAP that is gap-graded or single-sized will not be accepted."

**TEMPORARY PAVEMENT (D1)**

Effective: March 1, 2003

Revised: April 10, 2008

Description. This work shall consist of constructing a temporary pavement at the locations shown on the plans or as directed by the engineer.

The contractor shall use either Portland cement concrete according to Sections 353 and 354 of the Standard Specifications or HMA according to Sections 355, 356, 406 of the Standard Specifications, and other applicable HMA special provisions as contained herein. The HMA mixtures to be used shall be specified in the plans. The thickness of the Temporary Pavement shall be as described in the plans. The contractor shall have the option of constructing either material type if both Portland cement concrete and HMA are shown in the plans.

Articles 355.08 and 406.11 of the Standard Specifications shall not apply.

The removal of the Temporary Pavement, if required, shall conform to Section 440 of the Standard Specification.

Method of Measurement. Temporary pavement will be measured in place and the area computed in square yards (square meters).

Basis of Payment. This work will be paid for at the contract unit price per square yard (square meter) for TEMPORARY PAVEMENT and TEMPORARY PAVEMENT (INTERSTATE).

Removal of temporary pavement will be paid for at the contract unit price per square yard (square meter) for PAVEMENT REMOVAL.

**HOT-MIX ASPHALT BINDER AND SURFACE COURSE (D1)**

Effective: November 1, 2019

Revised: December 1, 2021

Revise Article 1004.03(c) to read:

“(c) Gradation. The coarse aggregate gradations shall be as listed in the following table.

Use	Size/Application	Gradation No.
Class A-1, A-2, & A-3	3/8 in. (10 mm) Seal	CA 16 or CA 20
Class A-1	1/2 in. (13 mm) Seal	CA 15
Class A-2 & A-3	Cover Coat	CA 14
HMA High ESAL	IL-19.0; Stabilized Subbase IL-19.0	CA 11 <sup>1/</sup>
	SMA 12.5 <sup>2/</sup>	CA 13 <sup>4/</sup> , CA 14, or CA 16
	SMA 9.5 <sup>2/</sup>	CA 13 <sup>3/4/</sup> or CA 16 <sup>3/</sup>
	IL-9.5	CA 16, CM 13 <sup>4/</sup>
	IL-9.5FG	CA 16
HMA Low ESAL	IL-19.0L	CA 11 <sup>1/</sup>
	IL-9.5L	CA 16

1/ CA 16 or CA 13 may be blended with the CA 11.

2/ The coarse aggregates used shall be capable of being combined with the fine aggregates and mineral filler to meet the approved mix design and the mix requirements noted herein.

3/ The specified coarse aggregate gradations may be blended.

4/ CA 13 shall be 100 percent passing the 1/2 in. (12.5mm) sieve.”

Revise Article 1004.03(e) of the Supplemental Specifications to read:

“(e) Absorption. For SMA the coarse aggregate shall also have water absorption ≤ 2.0 percent.”

Revise the “High ESAL” portion of the table in Article 1030.01 to read:

“High ESAL	Binder Courses	IL-19.0, IL-9.5, IL-9.5FG, IL-4.75, SMA 12.5, Stabilized Subbase IL-19.0
	Surface Courses	IL-9.5, IL-9.5FG, SMA 12.5, SMA 9.5”

Revise Note 2. and add Note 6 to Article 1030.02 of the Standard Specifications to read:

"Item	Article/Section
(g)Performance Graded Asphalt Binder (Note 6)	1032
(h)Fibers (Note 2)	

Note 2. A stabilizing additive such as cellulose or mineral fiber shall be added to the SMA mixture according to Illinois Modified AASHTO M 325. The stabilizing additive shall meet the Fiber Quality Requirements listed in Illinois Modified AASHTO M 325. Prior to approval and use of fibers, the Contractor shall submit a notarized certification by the producer of these materials stating they meet these requirements. Reclaimed Asphalt Shingles (RAS) may be used in Stone Matrix Asphalt (SMA) mixtures designed with an SBA polymer modifier as a fiber additive if the mix design with RAS included meets AASHTO T305 requirements. The RAS shall be from a certified source that produces either Type 1 or Type 2. Material shall meet requirements noted herein and the actual dosage rate will be determined by the Engineer.

Note 6. The asphalt binder shall be an SBS PG 76-28 when the SMA is used on a full-depth asphalt pavement and SBS PG 76-22 when used as an overlay, except where modified herein. The asphalt binder shall be a SBS PG 76-22 for IL-4.75, except where modified herein..”

Revise table in Article 1030.05(a) of the Standard Specifications to read:

"MIXTURE COMPOSITION (% PASSING) <sup>1/</sup>												
Sieve Size	IL-19.0 mm		SMA 12.5		SMA 9.5		IL-9.5mm		IL-9.5FG		IL-4.75 mm	
	min	max	min	max	min	max	min	max	min	max	min	max
1 1/2 in (37.5 mm)												
1 in. (25 mm)		100										
3/4 in. (19 mm)	90	100		100								
1/2 in. (12.5 mm)	75	89	80	100		100		100		100		100
3/8 in. (9.5 mm)				65	90	100	90	100	90	100		100
#4 (4.75 mm)	40	60	20	30	36	50	34	69	60	75 <sup>6/</sup>	90	100
#8 (2.36 mm)	20	42	16	24 <sup>4/</sup>	16	32 <sup>4/</sup>	34 <sup>5/</sup>	52 <sup>2/</sup>	45	60 <sup>6/</sup>	70	90
#16 (1.18 mm)	15	30					10	32	25	40	50	65
#30 (600 μm)			12	16	12	18			15	30		
#50 (300 μm)	6	15					4	15	8	15	15	30
#100 (150 μm)	4	9					3	10	6	10	10	18
#200 (75 μm)	3.0	6.0	7.0	9.0 <sup>3/</sup>	7.5	9.5 <sup>3/</sup>	4.0	6.0	4.0	6.5	7.0	9.0 <sup>3/</sup>
#635 (20 μm)			≤ 3.0		≤ 3.0							
Ratio Dust/Asphalt Binder		1.0		1.5		1.5		1.0		1.0		1.0

1/ Based on percent of total aggregate weight.

2/ The mixture composition shall not exceed 44 percent passing the #8 (2.36 mm) sieve for surface courses with Ndesign = 90.

3/ Additional minus No. 200 (0.075 mm) material required by the mix design shall be mineral filler, unless otherwise approved by the Engineer.

4/ When establishing the Adjusted Job Mix Formula (AJMF) the percent passing the #8 (2.36 mm) sieve shall not be adjusted above the percentage stated on the table.

5/ When establishing the Adjusted Job Mix Formula (AJMF) the percent passing the #8 (2.36 mm) sieve shall not be adjusted below 34 percent.

6/ When the mixture is used as a binder, the maximum shall be increased by 0.5 percent passing."

Revise Article 1030.05(b) of the Standard Specifications to read:

(b) Volumetric Requirements. The target value for the air voids of the HMA shall be 4.0 percent, for IL-4.75 and SMA mixtures it shall be 3.5 percent and for Stabilized Subbase it shall be 3.0 percent at the design number of gyrations. The voids in the mineral aggregate (VMA) and voids filled with asphalt binder (VFA) of the HMA design shall be based on the nominal maximum size of the aggregate in the mix and shall conform to the following requirements.

Mix Design	Voids in the Mineral Aggregate (VMA), % Minimum for Ndesign				
	30	50	70	80	90
IL-19.0		13.5	13.5		13.5
IL-9.5		15.0	15.0		
IL-9.5FG		15.0	15.0		
IL-4.75 <sup>1/</sup>		18.5			
SMA-12.5 <sup>1/2/5/</sup>				17.0 <sup>3/</sup> /16.0 <sup>4/</sup>	
SMA-9.5 <sup>1/2/5/</sup>				17.0 <sup>3/</sup> /16.0 <sup>4/</sup>	
IL-19.0L	13.5				
IL-9.5L	15.0				

- 1/ Maximum draindown shall be 0.3 percent according to Illinois Modified AASHTO T 305.
- 2/ The draindown shall be determined at the JMF asphalt binder content at the mixing temperature plus 30°F.
- 3/ Applies when specific gravity of coarse aggregate is  $\geq 2.760$ .
- 4/ Applies when specific gravity of coarse aggregate is  $< 2.760$ .
- 5/ For surface course, the coarse aggregate can be crushed steel slag, crystalline crushed stone or crushed sandstone. For binder course, coarse aggregate shall be crushed stone (dolomite), crushed gravel, crystalline crushed stone, or crushed sandstone”



Revise the last paragraph of Article 1102.01 (a) (5) of the Standard Specifications to read:

“IL-4.75 and Stone Matrix Asphalt (SMA) mixtures which contain aggregate having absorptions greater than or equal to 2.0 percent, or which contain steel slag sand, shall have minimum surge bin storage plus haul time of 1.5 hours.”

Add after third sentence of Article 1030.09(b) to read:

“If the Contractor and Engineer agree the nuclear density test method is not appropriate for the mixture, cores shall be taken at random locations determined according to the QC/QA document "Determination of Random Density Test Site Locations". Core densities shall be determined using the Illinois Modified AASHTO T 166 or T 275 procedure.”

Revise Table 1 and Note 4/ of Table 1 in Article 406.07(a) of the Standard Specifications to read:

	Breakdown/Intermediate Roller (one of the following)	Final Roller (one or more of the following)	Density Requirement
IL-9.5, IL-9.5FG, IL-19.0 <sup>1/</sup>	V <sub>D</sub> , P, T <sub>B</sub> , 3W, O <sub>T</sub> , O <sub>B</sub>	V <sub>S</sub> , T <sub>B</sub> , T <sub>F</sub> , O <sub>T</sub>	As specified in Section 1030
IL-4.75 and SMA <sup>3/ 4/</sup>	T <sub>B</sub> , 3W, O <sub>T</sub>	T <sub>F</sub> , 3W	As specified in Section 1030
Mixtures on Bridge Decks <sup>2/</sup>	T <sub>B</sub>	T <sub>F</sub>	As specified in Articles 582.05 and 582.06.

“4/ The Contractor shall provide a minimum of two steel-wheeled tandem rollers (T<sub>B</sub>), and/or three-wheel (3W) rollers for breakdown, except one of the (T<sub>B</sub>) or (3W) rollers shall be 84 inches (2.14 m) wide and a weight of 315 pound per linear inch (PLI) (5.63 kg/mm) and one of the (T<sub>B</sub>) or (3W) rollers can be substituted for an oscillatory roller (O<sub>T</sub>). T<sub>F</sub> rollers shall be a minimum of 280 lb/in. (50 N/mm). The 3W and T<sub>B</sub> rollers shall be operated at a uniform speed not to exceed 3 mph (5 km/h), with the drive roll for T<sub>B</sub> rollers nearest the paver and maintain an effective rolling distance of not more than 150 ft (45 m) behind the paver.”

Add the following after the fourth paragraph of Article 406.13 (b):

“The plan quantities of SMA mixtures shall be adjusted using the actual approved binder and surface Mix Design’s G<sub>mb</sub>.”

Revise first paragraph of Article 1030.10 of the Standard Specifications to read:

“A test strip of 300 ton (275 metric tons), except for SMA mixtures it will be 400 ton (363 metric ton), will be required for each mixture on each contract at the beginning of HMA production for each construction year according to the Manual of Test Procedures for Materials “Hot Mix Asphalt Test Strip Procedures”. At the request of the Producer, the Engineer may waive the test strip if previous construction during the current construction year has demonstrated the constructability of the mix using Department test results.”

Revise third paragraph of Article 1030.10 of the Standard Specifications to read:

“When a test strip is constructed, the Contractor shall collect and split the mixture according to the document “Hot-Mix Asphalt Test Strip Procedures”. The Engineer, or a representative, shall deliver split sample to the District Laboratory for verification testing. The Contractor shall complete mixture tests stated in Article 1030.09(a). Mixture sampled shall include enough material for the Department to conduct mixture tests detailed in Article 1030.09(a) and in the document “Hot-Mix Asphalt Mixture Design Verification Procedure” Section 3.3. The mixture test results shall meet the requirements of Articles 1030.05(b) and 1030.05(d), except Hamburg wheel tests will only be conducted on High ESAL mixtures during production.”

#### **PAVEMENT REMOVAL, SPECIAL (D1)**

Effective: January 13, 1989

Revised: January 1, 2007

This work consists of removing pavement at the locations shown on the plans in accordance with the requirements specified herein.

The only type of pavement removal permitted will be by lifting slabs of pavement. The Contractor shall saw cut the pavement full depth into slabs which can be lifted into trucks and shall be hauled away from the job site and disposed of properly.

The outlining saw cut must be made prior to breaking any pavement in adjacent lanes which is done by conventional methods.

Method of Measurement. This work will be measured for payment in square yards (square meters) of pavement surface.

Basis of Payment. This work will be paid for at the contract unit price per square yard (square meter) for PAVEMENT REMOVAL (SPECIAL).

**COFFERDAM (TYPE 1) (IN-STREAM/WETLAND WORK) (D1)**

Effective: January 1, 2019

Revised: August 15, 2022

Description. This work shall be performed in accordance with Section 502.06 of the Standard Specifications for Road and Bridge Construction, except as herein modified. The work shall consist of the preparation of an in-stream/wetland work plan and the installation, maintenance, removal and disposal of the temporary cofferdam(s) to isolate the work area from water within regulated wetlands and Waters of the U.S. (WOUS) in accordance with the authorized U.S. Army Corps of Engineers (USACE) Section 404 Permit and the General Conditions of the current Nationwide Permit Program.

Materials. Materials shall be in accordance with the USACE Section 404 Permit and General Conditions of the current Nationwide Permit Program.

Construction Requirements. Construction shall be in accordance with Article 502.06(a) of the Standard Specifications for Road and Bridge Construction and in accordance with the authorized USACE Section 404 Permit. For Cofferdam - Type 1, it is anticipated the design will be based on the flow requirement as shown in the plans and per the General Conditions of the current Nationwide Permit Program.

The Contractor shall be responsible for diverting the water flow from the construction area using a method meeting the approval of the Engineer and in accordance with the authorized USACE Section 404 Permit and General Conditions of the current Nationwide Permit Program.

This project requires a USACE Section 404 Permit prior to the start of work. All conditions of the Section 404 Permit must be followed. As a condition of the Section 404 Permit, the Contractor will be required to submit an In-Stream/Wetland Work Plan to the Department for approval. The USACE defines and determines in-stream/wetland work within the WOUS.

Guidelines on acceptable In-Stream/Wetland work techniques can be found on the USACE website: <https://www.lrc.usace.army.mil/Missions/Regulatory/Illinois/IL-Nationwide-Permits/>

Method of Measurement. This work will be measured for payment in units of Each where Each is defined as a plan detailed stage of bridge, culvert or other construction for which a temporary in-stream cofferdam(s) is required. If staged construction is not detailed/specified on the plans, this work will be measured as a total of One Each.

Basis of Payment. This work will be paid for at the contract unit price per each for COFFERDAM (TYPE 1) (IN-STREAM/WETLAND WORK).

**AGGREGATE FOR CONCRETE BARRIER (D1)**

Effective: February 11, 2004

Revised: January 24, 2008

Add the following paragraph to Article 637.02 of the Standard Specifications:

“The coarse aggregate to be used in the concrete barrier walls shall conform to the requirement for coarse aggregate used in Class BS concrete according to Article 1004.01(b), paragraph 2.”

**ENGINEER’S FIELD OFFICE TYPE A (SPECIAL) (D1)**

Effective: December 1, 2011

Revised: May 1, 2013

Revise the first paragraph of Article 670.02 to read:

**670.02 Engineer's Field Office Type A (Special).** Type A (Special) field offices shall have a ceiling height of not less than 7 feet and a floor space of not less than 3000 square feet with a minimum of two separate offices. The office shall also have a separate storage room capable of being locked for the storage of the nuclear measuring devices. The office shall be provided with sufficient heat, natural and artificial light, and air conditioning. Doors and windows shall be equipped with locks approved by the Engineer.

Revise the first sentence of the second paragraph of Article 670.02 to read:

An electronic security system that will respond to any breach of exterior doors and windows with an on-site alarm shall be provided.

Revise the last sentence of the third paragraph of Article 670.02 to read:

Adequate all-weather parking space shall be available to accommodate a minimum of twelve vehicles.

Revise the fifth paragraph of Article 670.02 to read:

Sanitary facilities shall include hot and cold potable running water, lavatory and toilet as an integral part of the office where available. Solid waste disposal consisting of seven waste baskets and an outside trash container of sufficient size to accommodate a weekly provided pick-up service. A weekly cleaning service for the office shall be provided.

Revise subparagraph (a) of Article 670.02 to read:

(a) Twelve desks with minimum working surface 42 inch x 30 inch each and twelve non-folding chairs with upholstered seats and backs.

Revise the first sentence of subparagraph (c) of Article 670.02 to read:

- (c) Two four-post drafting tables with minimum top size of 37-½ inch x 48 inch.

Revise subparagraph (d) of Article 670.02 to read:

- (d) Eight free standing four-drawer legal size file cabinets with lock and an underwriters' laboratories insulated file device 350 degrees one hour rating.

Revise subparagraph (e) of Article 670.02 to read:

- (e) Twenty folding chairs and two conference tables with minimum top size of 44 inch x 96 inch.

Revise subparagraph (h) of Article 670.02 to read:

- (h) Three electric desk type tape printing calculator and two pocket scientific notation calculators with a 1000 hour battery life or with a portable recharger.

Revise subparagraph (i)(2) of Article 670.02 to read:

- (i)(2) Telephones lines. Five separate telephone lines including one line for the fax machine, and two lines for the exclusive use of the Engineer. All telephone lines shall include long distance service and all labor and materials necessary to install the phone lines at the locations directed by the Engineer. The TELCOM company shall configure ROLL/HUNT features as specified by the engineer.

Revise subparagraph (j) of Article 670.02 to read:

- (j) Two plain paper network multi-function printer/copier/scanner machines capable of reproducing prints up to 11 inch x 17 inch within automatic feed tray capable of sorting 30 sheets of paper. Letter size and 11 inch x 17 inch paper shall be provided. The contractor shall provide the multi-function machines with IT support for setup and maintenance.

Revise subparagraph (k) of Article 670.02 to read:

- (k) One plain paper fax machine including maintenance and supplies.

Revise subparagraph (l) of Article 670.02 to read:

- (l) Six four-line telephones, with touch tone, where available, and two digital answering machines, for exclusive use by the Engineer.

Revise subparagraph (m) of Article 670.02 to read:

- (m) One electric water cooler dispenser including water service.

Add the following subparagraphs to Article 670.02:

- (s) One 4 foot x 6 foot chalkboard or dry erase board.
- (t) One 4 foot x 6 foot framed cork board.

Add the following to Article 670.07 Basis of Payment.

The building or buildings, fully equipped, will be paid for at the contract unit price per calendar month or fraction thereof for ENGINEER'S FIELD OFFICE, TYPE A (SPECIAL).

### **TRAFFIC CONTROL PLAN (D1)**

Effective: September 30, 1985

Revised: January 1, 2007

Traffic Control shall be according to the applicable sections of the Standard Specifications, the Supplemental Specifications, the "Illinois Manual on Uniform Traffic Control Devices for Streets and Highways", any special details and Highway Standards contained in the plans, and the Special Provisions contained herein.

Special attention is called to Article 107.09 of the Standard Specifications and the following Highway Standards, Details, Quality Standard for Work Zone Traffic Control Devices, Recurring Special Provisions and Special Provisions contained herein, relating to traffic control.

The Contractor shall contact the District One Bureau of Traffic at least 72 hours in advance of beginning work.

#### STANDARDS:

701001, 701006, 701106, 701400, 701401, 701411, 701446, 701428, 701901, 704001, 782006

#### DETAILS:

- ENTRANCE AND EXIT RAMP CLOSURE DETAILS (TC-08)
- TRAFFIC CONTROL DETAILS FOR FREEWAY SINGLE & MULTI-LANE WEAVE (TC-09)
- MULTI-LANE FREEWAY PAVEMENT MARKING DETAILS (TC-12)
- TRAFFIC CONTROL DETAILS FOR FREEWAY SHOULDER CLOSURES AND PARTIAL RAMP CLOSURES (TC-17)
- FREEWAY / EXPRESSWAY SIGNING FOR FLAGGING OPERATIONS AT WORK ZONE OPENINGS ON FREEWAYS / EXPRESSWAYS (TC-18)

**SPECIAL PROVISIONS:**

- Maintenance of Roadways (D-1)
- Public Convenience and Safety (D-1)
- Keeping The Expressway Open To Traffic
- Failure To Open Traffic Lanes To Traffic
- Traffic Control And Protection (Expressways)
- Traffic Control Surveillance (Expressways)
- Traffic Control For Work Zone Areas
- Speed Display Trailer (D1)
- Traffic Spotters (BDE)
- Vehicle and Equipment Warning Lights (BDE)
- Work Zone Traffic Control Devices (BDE)

**FRICITION AGGREGATE (D1)**

Effective: January 1, 2011  
 Revised: December 1, 2021

Revise Article 1004.03(a) of the Standard Specifications to read:

**“1004.03 Coarse Aggregate for Hot-Mix Asphalt (HMA).** The aggregate shall be according to Article 1004.01 and the following.

(a) Description. The coarse aggregate for HMA shall be according to the following table.

Use	Mixture	Aggregates Allowed
Class A	Seal or Cover	<u>Allowed Alone or in Combination</u> <sup>5/</sup> : Gravel Crushed Gravel Carbonate Crushed Stone Crystalline Crushed Stone Crushed Sandstone Crushed Slag (ACBF) Crushed Steel Slag Crushed Concrete
HMA Low ESAL	Stabilized Subbase or Shoulders	<u>Allowed Alone or in Combination</u> <sup>5/</sup> : Gravel Crushed Gravel Carbonate Crushed Stone Crystalline Crushed Stone Crushed Sandstone Crushed Slag (ACBF) Crushed Steel Slag <sup>1/</sup> Crushed Concrete

Use	Mixture	Aggregates Allowed	
HMA High ESAL Low ESAL	Binder IL-19.0 or IL-19.0L  SMA Binder	<u>Allowed Alone or in Combination</u> <sup>5/ 6/</sup> : Crushed Gravel Carbonate Crushed Stone <sup>2/</sup> Crystalline Crushed Stone Crushed Sandstone Crushed Slag (ACBF) Crushed Concrete <sup>3/</sup>	
HMA High ESAL Low ESAL	C Surface and Binder IL-9.5 IL-9.5FG or IL-9.5L	<u>Allowed Alone or in Combination</u> <sup>5/</sup> : Crushed Gravel Carbonate Crushed Stone <sup>2/</sup> Crystalline Crushed Stone Crushed Sandstone Crushed Slag (ACBF) Crushed Steel Slag <sup>4/</sup> Crushed Concrete <sup>3/</sup>	
HMA High ESAL	D Surface and Binder IL-9.5 or IL-9.5FG	<u>Allowed Alone or in Combination</u> <sup>5/</sup> : Crushed Gravel Carbonate Crushed Stone (other than Limestone) <sup>2/</sup> Crystalline Crushed Stone Crushed Sandstone Crushed Slag (ACBF) Crushed Steel Slag <sup>4/</sup>	
		<u>Other Combinations Allowed:</u>	
		<i>Up to...</i>	<i>With...</i>
		25% Limestone	Dolomite
		50% Limestone	Any Mixture D aggregate other than Dolomite
75% Limestone	Crushed Slag (ACBF) or Crushed Sandstone		
HMA High ESAL	E Surface IL-9.5  SMA Ndesign 80 Surface	<u>Allowed Alone or in Combination</u> <sup>5/ 6/</sup> : Crushed Gravel Crystalline Crushed Stone Crushed Sandstone Crushed Slag (ACBF) Crushed Steel Slag  No Limestone.	



Use	Mixture	Aggregates Allowed	
		<u>Other Combinations Allowed:</u>	
		<i>Up to...</i>	<i>With...</i>
		50% Dolomite <sup>2/</sup>	Any Mixture E aggregate
		75% Dolomite <sup>2/</sup>	Crushed Sandstone, Crushed Slag (ACBF), Crushed Steel Slag, or Crystalline Crushed Stone
		75% Crushed Gravel <sup>2/</sup>	Crushed Sandstone, Crystalline Crushed Stone, Crushed Slag (ACBF), or Crushed Steel Slag
HMA High ESAL	F Surface IL-9.5  SMA Ndesign 80 Surface	<u>Allowed Alone or in Combination</u> <sup>5/ 6/</sup> :	
		Crystalline Crushed Stone Crushed Sandstone Crushed Slag (ACBF) Crushed Steel Slag No Limestone.	
		<u>Other Combinations Allowed:</u>	
		<i>Up to...</i>	<i>With...</i>
		50% Crushed Gravel <sup>2/</sup> or Dolomite <sup>2/</sup>	Crushed Sandstone, Crushed Slag (ACBF), Crushed Steel Slag, or Crystalline Crushed Stone

- 1/ Crushed steel slag allowed in shoulder surface only.
- 2/ Carbonate crushed stone (limestone) and/or crushed gravel shall not be used in SMA Ndesign 80.
- 3/ Crushed concrete will not be permitted in SMA mixes.
- 4/ Crushed steel slag shall not be used as binder.
- 5/ When combinations of aggregates are used, the blend percent measurements shall be by volume.”
- 6/ Combining different types of aggregate will not be permitted in SMA Ndesign 80.”

**SLIPFORM PAVING (D1)**

Effective: November 1, 2014

Revise Article 1020.04 Table 1, Note (5) of Standard Specifications to read:

“The slump range for slipform construction shall be 1/2 to 1 1/2 in.”

Revise Article 1020.04 Table 1 (metric), Note (5) of Standard Specifications to read:

“The slump range for slipform construction shall be 13 to 40 mm.”

**HOT-MIX ASPHALT – MIXTURE DESIGN VERIFICATION AND PRODUCTION (D1)**

Effective: January 1, 2019

Revised: December 1, 2021

Add to Article 1030.05 (d)(3) of the Standard Specifications to read:

“ During mixture design, prepared samples shall be submitted to the District laboratory by the Contractor for verification testing. The required testing, and number and size of prepared samples submitted, shall be according to the following tables.

High ESAL – Required Samples for Verification Testing	
Mixture	Hamburg Wheel and I-FIT Testing <sup>1/2/</sup>
Binder	total of 3 - 160 mm tall bricks
Surface	total of 4 - 160 mm tall bricks

Low ESAL – Required Samples for Verification Testing	
Mixture	I-FIT Testing <sup>1/2/</sup>
Binder	1 - 160 mm tall brick
Surface	2 - 160 mm tall bricks

1/ The compacted gyratory bricks for Hamburg wheel and I-FIT testing shall be 7.5 ± 0.5 percent air voids.

2/ If the Contractor does not possess the equipment to prepare the 160 mm tall brick(s), twice as many 115 mm tall compacted gyratory bricks will be acceptable.

Revise the fourth paragraph of Article 1030.10 of the Standard Specifications to read:

“When a test strip is not required, each HMA mixture shall still be sampled on the first day of production: I-FIT and Hamburg wheel testing for High ESAL; I-FIT testing for Low ESAL. Within two working days after sampling the mixture, the Contractor shall deliver gyratory cylinders to the District laboratory for Department verification testing. The High ESAL mixture test results shall meet the requirements of Articles 1030.05(d)(3) and 1030.05(d)(4). The Low ESAL mixture test results shall meet the requirements of Article 1030.05(d)(4). The required number and size of prepared samples submitted for the Hamburg wheel and I-FIT testing shall be according to the “High ESAL - Required Samples for Verification Testing” table in Article 1030.05(d)(3) above.”

Add the following to the end of Article 1030.10 of the Standard Specifications to read:

“Mixture sampled during first day of production shall include approximately 60 lb (27 kg) of additional material for the Department to conduct Hamburg wheel testing and approximately 80 lb (36 kg) of additional material for the Department to conduct I-FIT testing. Within two working days after sampling, the Contractor shall deliver prepared samples to the District laboratory for verification testing. The required number and size of prepared samples submitted for the Hamburg wheel and I-FIT testing shall be according to the “High ESAL - Required Samples for Verification Testing” table in Article 1030.05(d)(3) above.”

## **GENERAL ELECTRICAL REQUIREMENTS**

Effective: June 1, 2021

This special provision replaces Articles 801.01 – 801.07, 801.09 – 801-16 of the Standard Specifications.

**Definition.** Codes, standards, and industry specifications cited for electrical work shall be by definition the latest adopted version thereof, unless indicated otherwise.

Materials by definition shall include electrical equipment, fittings, devices, motors, appliances, fixtures, apparatus, all hardware and appurtenances, and the like, used as part of, or in connection with, electrical installation.

**Standards of Installation.** Materials shall be installed according to the manufacturer’s recommendations, the NEC, OSHA, the NESC, and AASHTO’s Standard Specifications for Structural Supports for Highway Signs, Luminaires, and Traffic Signals.

All like materials shall be from the same manufacturer. Listed and labeled materials shall be used whenever possible. The listing shall be according to UL or an approved equivalent.

**Safety and Protection.** Safety and protection requirements shall be as follows.

**Safety.** Electrical systems shall not be left in an exposed or otherwise hazardous condition. All electrical boxes, cabinets, pole handholes, etc. which contain wiring, either energized or non-energized, shall be closed or shall have covers in place and be locked when possible, during nonworking hours.

**Protection.** Electrical raceway or duct openings shall be capped or otherwise sealed from the entrance of water and dirt. Wiring shall be protected from mechanical injury.

**Equipment Grounding Conductor.** All electrical systems, materials, and appurtenances shall be grounded. Good ground continuity throughout the electrical system shall be assured, even though every detail of the requirements is not specified or shown. Electrical circuits shall have a continuous insulated equipment grounding conductor. When metallic conduit is used, it shall be bonded to the equipment grounding conductor, but shall not be used as the equipment grounding conductor.

Detector loop lead-in circuits, circuits under 50 volts, and runs of fiber optic cable will not require an equipment grounding conductor.

Where connections are made to painted surfaces, the paint shall be scraped to fully expose metal at the connection point. After the connection is completed, the paint system shall be repaired to the satisfaction of the Engineer.

Bonding of all boxes and other metallic enclosures throughout the wiring system to the equipment grounding conductor shall be made using a splice and pigtail connection. Mechanical connectors shall have a serrated washer at the contact surface.

All connections to structural steel or fencing shall be made with exothermic welds. Care shall be taken not to weaken load carrying members. Where connections are made to epoxy coated reinforcing steel, the epoxy coating shall be sufficiently removed to facilitate a mechanical connection. The epoxy coating shall be repaired to the satisfaction of the Engineer. Where connections are made to insulated conductors, the connection shall be wrapped with at least four layers of electrical tape extended 6 in. (150 mm) onto the conductor insulation.

**Submittals.** At the preconstruction meeting, the Contractor shall submit a written listing of manufacturers for all major electrical and mechanical items. The list of manufacturers shall be binding, except by written request from the Contractor and approval by the Engineer. The request shall include acceptable reasons and documentation for the change.

Within 30 calendar days after contract execution, the Contractor shall submit, for approval, through the Traffic Operations Construction Submittals Application (TOCS) system the manufacturer's product data (for standard products and components) and detailed shop drawings (for fabricated items). Submittals for the materials for each individual pay item shall be complete in every respect. Submittals which include multiple pay items shall have all submittal material for each item or group of items covered by a particular specification, grouped together and the applicable pay item identified. Various submittals shall, when taken together, form a complete coordinated package. A partial submittal will be returned without review unless prior written permission is obtained from the Engineer.

Each PDF document must be a vector format PDF from the originating supplier or program and not scanned images.

The submittal must clearly identify the specific model number or catalog number of the item being proposed.

For further information and requirements regarding the TOCS system, the Contractor should reference the *TOCS Contractors User Guide*.

The submittal shall be properly identified by route, section, county, and contract number.

The Contractor shall have reviewed the submittal material and affixed his/her stamp of approval, with date and signature, for each individual item.

Illegible print, incompleteness, inaccuracy, or lack of coordination will be grounds for rejection.

**Items from multiple disciplines shall not be combined on a single submittal and transmittal. Items for lighting, signals, surveillance and CCTV must be in separate submittals since they may be reviewed by various personnel in various locations.**

The Department may provide a list of pay items broken out by discipline upon request for a particular contract.

The Engineer will review the submittals for conformance with the design concept of the project according to Article 105.04 and the following. The Engineer will stamp the drawings indicating their status as "Approved", "Approved as Noted", "Disapproved", or "Information Only". Since the Engineer's review is for conformance with the design concept only, it shall be the Contractor's responsibility to coordinate the various items into a working system as specified. The Contractor shall not be relieved from responsibility for errors or omissions in the shop, working, or layout drawings by the Engineer's approval thereof. The Contractor shall still be in full compliance with contract and specification requirements.

All submitted items reviewed and marked "Disapproved" or "Approved as Noted" shall be resubmitted by the Contractor in their entirety, unless otherwise indicated within the submittal comments.

Work shall not begin until the Engineer has approved the submittal. Material installed prior to approval by the Engineer, will be subject to removal and replacement at no additional cost to the Department.

**Certifications.** When certifications are specified and are available prior to material manufacture, the certification shall be included in the submittal information. When specified and only available after manufacture, the submittal shall include a statement of intent to furnish certification. All certificates shall be complete with all appropriate test dates and data.

**Authorized Project Delay.** See Article 801.08

**Maintenance transfer and Preconstruction Inspection:**

General. Before performing any excavation, removal, or installation work (electrical or otherwise) at the site, the Contractor shall request a maintenance transfer and preconstruction site inspection, to be held in the presence of the Engineer and a representative of the party or parties responsible for maintenance of any lighting and/or traffic control systems which may be affected by the work. The request for the maintenance transfer and preconstruction inspection shall be made no less than fourteen (14) calendar days prior to the desired inspection date. The maintenance transfer and preconstruction inspection shall:

Establish the procedures for formal transfer of maintenance responsibility required for the construction period.

Establish the approximate location and operating condition of lighting and/or traffic control systems which may be affected by the work

Marking of Existing Cable Systems. The party responsible for maintenance of any existing lighting and/or traffic control systems at the project site will, at the Contractor's request, mark and/or stake, once per location, all underground cable routes owned or maintained by the State. A project may involve multiple "locations" where separated electrical systems are involved (i.e. different controllers). The markings shall be taken to have a horizontal tolerance of at least 1 foot (304.8 mm) to either side. The request for the cable locations and marking shall be made at the same time the request for the maintenance transfer and preconstruction inspection is made. The Contractor shall exercise extreme caution where existing buried cable runs are involved. The markings of existing systems are made strictly for assistance to the Contractor and this does not relieve the Contractor of responsibility for the repair or replacement of any cable run damaged in the course of his work, as specified elsewhere herein. Note that the contractor shall be entitled to only one request for location marking of existing systems and that multiple requests may only be honored at the contractor's expense. No locates will be made after maintenance is transferred, unless it is at the contractor's expense.

Condition of Existing Systems. The Contractor shall conduct an inventory of all existing electrical system equipment within the project limits, which may be affected by the work, making note of any parts which are found broken or missing, defective or malfunctioning. Megger and load readings shall be taken for all existing circuits which will remain in place or be modified. If a circuit is to be taken out in its entirety, then readings do not have to be taken. The inventory and test data shall be reviewed with and approved by the Engineer and a record of the inventory shall be submitted to the Engineer for the record. Without such a record, all systems transferred to the Contractor for maintenance during construction shall be returned at the end of construction in complete, fully operating condition.”

### **Maintenance and Responsibility During Construction.**

Lighting Operation and Maintenance Responsibility. The scope of work shall include the assumption of responsibility for the continuing operation and maintenance of the existing, proposed, temporary, sign and navigation lighting, or other lighting systems and all appurtenances affected by the work as specified elsewhere herein. Maintenance of lighting systems is specified elsewhere and will be paid for separately

The proposed lighting system must be operational prior to opening the roadway to traffic unless temporary lighting exists which is designed and installed to properly illuminate the roadway.

Energy and Demand Charges. The payment of basic energy and demand charges by the electric utility for existing lighting which remains in service will continue as a responsibility of the Owner, unless otherwise indicated. Unless otherwise indicated or required by the Engineer duplicate lighting systems (such as temporary lighting and proposed new lighting) shall not be operated simultaneously at the Owner's expense and lighting systems shall not be kept in operation during long daytime periods at the Owner's expense. Upon written authorization from the Engineer to place a proposed new lighting system in service, whether the system has passed final acceptance or not, (such as to allow temporary lighting to be removed), the Owner will accept responsibility for energy and demand charges for such lighting, effective the date of authorization. All other energy and demand payments to the utility shall be the responsibility of the Contractor until final acceptance.

**Damage to Electrical Systems.** Should damage occur to any existing electrical systems through the Contractor's operations, the Engineer will designate the repairs as emergency or non-emergency in nature.

Emergency repairs shall be made by the Contractor, or as determined by the Engineer, the Department, or its agent. Non-emergency repairs shall be performed by the Contractor within six working days following discovery or notification. All repairs shall be performed in an expeditious manner to assure all electrical systems are operational as soon as possible. The repairs shall be performed at no additional cost to the Department.

Lighting. An outage will be considered an emergency when three or more lights on a circuit or three successive lights are not operational. Knocked down materials, which result in a danger to the motoring public, will be considered an emergency repair.

Temporary aerial multi-conductor cable, with grounded messenger cable, will be permitted if it does not interfere with traffic or other operations, and if the Engineer determines it does not require unacceptable modification to existing installations.

**Marking Proposed Locations for Highway Lighting System.** The Contractor shall mark or stake the proposed locations of all poles, cabinets, junction boxes, pull boxes, handholes, cable routes, pavement crossings, and other items pertinent to the work. A proposed location inspection by the Engineer shall be requested prior to any excavation, construction, or installation work after all proposed installation locations are marked. Any work installed without location approval is subject to corrective action at no additional cost to the Department.

**Inspection of electrical work.** Inspection of electrical work shall be according to Article 105.12 and the following.

Before any splice, tap, or electrical connection is covered in handholes, junction boxes, light poles, or other enclosures, the Contractor shall notify and make available such wiring for the Engineer's inspection.

**Testing.** Before final inspection, the electrical work shall be tested. Tests may be made progressively as parts of the work are completed or may be made when the work is complete. Tests shall be made in the presence of the Engineer. Items which fail to test satisfactorily shall be repaired or replaced. Tests shall include checks of control operation, system voltages, cable insulation, and ground resistance and continuity.

The forms for recording test readings will be available from the Engineer in electronic format. The Contractor shall provide the Engineer with a written report of all test data including the following:

- Voltage Tests
- Amperage Tests
- Insulation Resistance Tests
- Continuity tests
- Detector Loop Tests

Lighting systems. The following tests shall be made.

- (1) Voltage Measurements. Voltages in the cabinet from phase to phase and phase to neutral, at no load and at full load, shall be measured and recorded. Voltage readings at the last termination of each circuit shall be measured and recorded.



- (2) Insulation Resistance. Insulation resistance to ground of each circuit at the cabinet shall be measured and recorded with all loads disconnected. Prior to performance of the insulation resistance test, the Contractor shall remove all fuses within all light pole bases on a circuit to segregate the luminaire loads.

On tests of new cable runs, the readings shall exceed 50 megohms for phase and neutral conductors with a connected load over 20A and shall exceed 100 megohms for conductors with a connected load of 20A or less.

On tests of cable runs which include cables which were existing in service prior to this contract, the resistance readings shall be the same or better than the readings recorded at the maintenance transfer at the beginning of the contract. Measurements shall be taken with a megohm meter approved by the Engineer.

- (3) Loads. The current of each circuit, phase main, and neutral shall be measured and recorded. The Engineer may direct reasonable circuit rearrangement. The current readings shall be within ten percent of the connected load based on material ratings.
- (4) Ground Continuity. Resistance of the system ground as taken from the farthest extension of each circuit run from the controller (i.e. check of equipment ground continuity for each circuit) shall be measured and recorded. Readings shall not exceed 2.0 ohms, regardless of the length of the circuit.
- (5) Resistance of Grounding Electrodes. Resistance to ground of all grounding electrodes shall be measured and recorded. Measurements shall be made with a ground tester during dry soil conditions as approved by the Engineer. Resistance to ground shall not exceed 10 ohms.

ITS. The following test shall be made in addition to the lighting system test above.

Detector Loops. Before and after permanently securing the loop in the pavement, the resistance, inductance, resistance to ground, and quality factor for each loop and lead-in circuit shall be tested. The loop and lead-in circuit shall have an inductance between 20 and 2500 microhenries. The resistance to ground shall be a minimum of 50 megohms under any conditions of weather or moisture. The quality factor (Q) shall be 5 or greater.

Fiber Optic Systems. Fiber optic testing shall be performed as required in the fiber optic cable special provision and the fiber optic splice special provision.

All test results shall be furnished to the Engineer seven working days before the date the inspection is scheduled.

**Contract Guarantee.** The Contractor shall provide a written guarantee for all electrical work provided under the contract for a period of six months after the date of acceptance with the following warranties and guarantees.

- (a) The manufacturer's standard written warranty for each piece of electrical material or apparatus furnished under the contract. The warranty for light emitting diode (LED) modules, including the maintained minimum luminance, shall cover a minimum of 120 months from the date of delivery.
- (b) The Contractor's written guarantee that, for a period of six months after the date of final acceptance of the work, all necessary repairs to or replacement of said warranted material or apparatus for reasons not proven to have been caused by negligence on the part of the user or acts of a third party shall be made by the Contractor at no additional cost to the Department.
- (c) The Contractor's written guarantee for satisfactory operation of all electrical systems furnished and constructed under the contract for a period of six months after final acceptance of the work.

The warranty for an uninterruptable power supply (UPS) shall cover a minimum of two years from date the equipment is placed in operation; however, the batteries of the UPS shall be warranted for full replacement for a minimum of five years.

**Record Drawings.** Alterations and additions to the electrical installation made during the execution of the work shall be made on the PDF copy of the as-Let documents using a PDF editor. Hand drawn notations or markups and scanned plans are not acceptable. These drawings shall be updated daily and shall be available for inspection by the Engineer during the work. The record drawings shall include the following:

- Cover Sheet
- The Electrical Maintenance Contract Management System (EMCMS) location designation, i.e. "L" number
- Summary of Quantities, electrical items only
- Legends, Schedules, and Notes
- Plan Sheets
- Pertinent Details
- Single Line Diagrams
- Other useful information useful to locate and maintain the systems.

Any modifications to the details shall be indicated. Final quantities used shall be indicated on the Summary of Quantities. Foundation depths used shall also be listed.

As part of the record drawings, the Contractor shall inventory all materials, new or existing, on the project and record information on inventory sheets provided by the Engineer.

The inventory shall include:

- Location of Equipment, including rack, chassis, slot as applicable.
- Designation of Equipment
- Equipment manufacturer
- Equipment model number
- Equipment Version Number
- Equipment Configuration
  - Addressing, IP or other
  - Settings, hardware or programmed
- Equipment Serial Number

The following electronic inventory forms are available from the Engineer:

- Lighting Controller Inventory
- Lighting Inventory
- Light Tower Inspection Checklist
- ITS Location Inventory

The information shall be entered in the forms; handwritten entries will not be acceptable; except for signatures. Electronic file shall also be included in the documentation.

When the work is complete, and seven days before the request for a final inspection, the set of contract drawings, stamped "**RECORD DRAWINGS**", shall be submitted to the Engineer for review and approval and shall be stamped with the date and the signature of the Contractor's supervising Engineer or Electrician. . The record drawings shall be submitted in PDF format through TOCS, on CD-ROM as well as hardcopy's for review and approval.

In addition to the record drawings, PDF copies of the final catalog cuts which have been Approved and Approved as Noted with applicable follow-up shall be submitted along with the record drawings. The PDF files shall clearly indicate either by filename or PDF table of contents the respective pay item number. Specific part or model numbers of items which have been selected shall be clearly visible. Hard copies of the catalog are not required with this submittal.

The Contractor shall provide three sets of electronically produced drawings in a moisture proof pouch to be kept on the inside door of the controller cabinet or other location approved by the Engineer. These drawings shall show the final as-built circuit orientation(s) of the project in the form of a single line diagram with all luminaires numbered and clearly identified for each circuit.

Final documentation shall be submitted as a complete submittal package, i.e. record drawings, test results, inventory, etc. shall be submitted at the same time. Partial piecemeal submittals will be rejected without review.

A total of three hardcopies and two CD-ROMs of the final documentation shall be submitted. The identical material shall also be submitted through the TOCS system utilizing the following final documentation pay item numbers:

<b>Pay Code</b>	<b>Description</b>	<b>Discipline</b>
FDLRD000	Record Drawings - Lighting	Lighting
FDSRD000	Record Drawings - Surveillance	Surveillance
FDTRD000	Record Drawings - Traffic Signal	Traffic Signal
FDIRD000	Record Drawings - ITS	ITS
FDLCC000	Catalog Cuts - Lighting	Lighting
FDSCC000	Catalog Cuts – Surveillance	Surveillance
FDTCC000	Catalog Cuts – Traffic Signal	Traffic Signal
FDICC000	Catalog Cuts - ITS	ITS
FDLWL000	Warranty - Lighting	Lighting
FDSWL000	Warranty - Surveillance	Surveillance
FDTWL000	Warranty - Traffic Signal	Traffic Signal
FDIWL000	Warranty - ITS	ITS
FDLTR000	Test Results - Lighting	Lighting
FDSTR000	Test Results - Surveillance	Surveillance
FDTTR000	Test Results - Traffic Signal	Traffic Signal
FDITR000	Test Results - ITS	ITS
FDLINV00	Inventory - Lighting	Lighting
FDSINV00	Inventory - Surveillance	Surveillance
FDTINV00	Inventory - Traffic Signal	Traffic Signal
FDIINV00	Inventory - ITS	ITS
FDLGPS00	GPS - Lighting	Lighting
FDSGPS00	GPS - Surveillance	Surveillance
FDTGPS00	GPS - Traffic Signal	Traffic Signal
FDIGPS00	GPS - ITS	ITS

Record Drawings shall include Marked up plans, controller info, Service Info, Equipment Settings, Manuals, Wiring Diagrams for each discipline.

Test results shall be all electrical test results, fiber optic OTDR, and Fiber Optic power meter as applicable for each discipline.

GPS Documentation. In addition to the specified record drawings, the Contactor shall record GPS coordinates of the following electrical components being installed, modified or being affected in other ways by this contract:

- All light poles and light towers.
- Handholes and vaults.
- Junction Boxes
- Conduit roadway crossings.
- Controllers.
- Control Buildings.
- Structures with electrical connections, i.e. DMS, lighted signs.
- Electric Service locations.
- CCTV Camera installations.
- Roadway Surveillance installations.
- Fiber Optic Splice Locations.
- Fiber Optic Cables. Coordinates shall be recorded along each fiber optic cable route every 200 feet.
- All fiber optic slack locations shall be identified with quantity of slack cable included. When sequential cable markings are available, those markings shall be documented as cable marking into enclosure and marking out of enclosure.

Datum to be used shall be North American 1983.

Data shall be provided electronically. The electronic format shall be compatible with MS Excel. Latitude and Longitude shall be in decimal degrees with a minimum of 6 decimal places. Each coordinate shall have the following information:

1. District
2. Description of item
3. Designation
4. Use
5. Approximate station
6. Contract Number
7. Date
8. Owner
9. Latitude
10. Longitude
11. Comments

A spreadsheet template will be available from the Engineer for use by the Contractor.

Accuracy. Data collected is to be mapping grade. A handheld mapping grade GPS device shall be used for the data collection. The receiver shall support differential correction and data shall have minimum 5 meter accuracy after post processing.

GPS receivers integrated into cellular communication devices, recreational and automotive GPS devices are not acceptable.

The GPS shall be the product of an established major GPS manufacturer having been in the business for a minimum of 6 years.”

The documents on the CD shall be organized by the Electrical Maintenance Contract Management System (EMCMS) location designation. If multiple EMCMS locations are within the contract, separate folders shall be utilized for each location as follows:

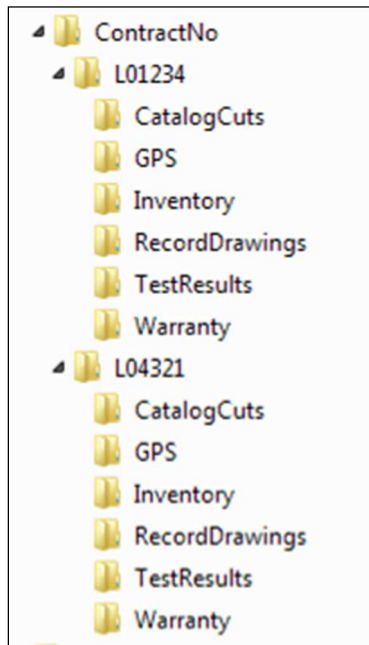

Extraneous information not pertaining to the specific EMCMS location shall not be included in that particular folder and sub-folder.

The inspection will not be made until after the delivery of acceptable record drawings, specified certifications, and the required guarantees.

The Final Acceptance Documentation Checklist shall be completed and is contained elsewhere herein.

All CD's shall be labeled as illustrated in the CD Label Template contained herein.

**Acceptance.** Acceptance of electrical work will be given at the time when the Department assumes the responsibility to protect and maintain the work according to Article 107.30 or at the time of final inspection.

When the electrical work is complete, tested, and fully operational, the Contractor shall schedule an inspection for acceptance with the Engineer no less than seven working days prior to the desired inspection date. The Contractor shall furnish the necessary labor and equipment to make the inspection.

A written record of the test readings taken by the Contractor according to Article 801.13 shall be furnished to the Engineer seven working days before the date the inspection is scheduled. Inspection will not be made until after the delivery of acceptable record drawings, specified certifications, and the required guarantees.

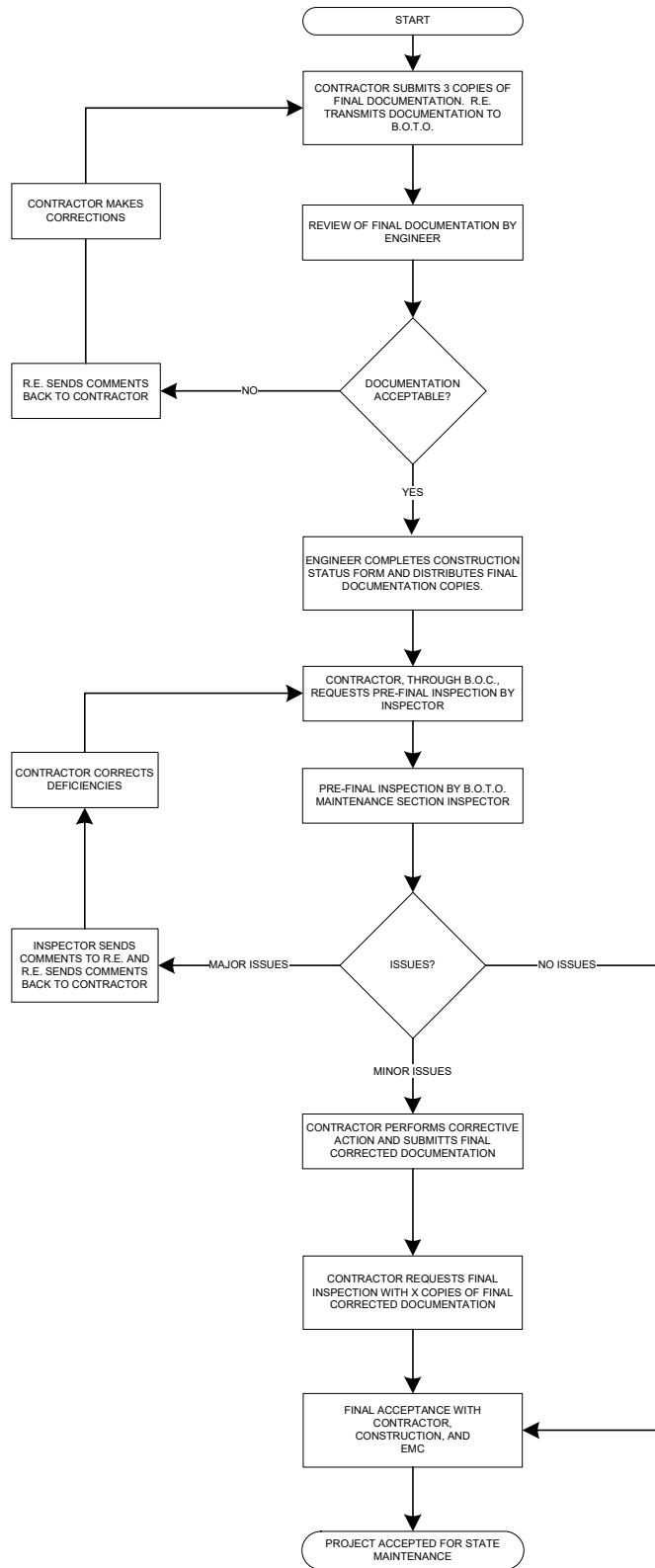



### Final Acceptance Documentation Checklist

LOCATION	
Route	Common Name
Limits	Section
Contract #	County
Controller Designation(s)	EMC Database Location Number(s)

ITEM	Contractor (Verify)	Resident Engineer (Verify)
<b>Record Drawings</b> -Three hardcopies (11" x 17") -Scanned to two CD-ROMs	<input type="checkbox"/> <input type="checkbox"/>	<input type="checkbox"/> <input type="checkbox"/>
<b>Field Inspection Tests</b> -Voltage -Amperage -Cable Insulation Resistance -Continuity -Controller Ground Rod Resistance (Three Hardcopies & scanned to two CD's)	<input type="checkbox"/> <input type="checkbox"/> <input type="checkbox"/> <input type="checkbox"/> <input type="checkbox"/>	<input type="checkbox"/> <input type="checkbox"/> <input type="checkbox"/> <input type="checkbox"/> <input type="checkbox"/>
<b>GPS Coordinates</b> -Excel file (Check Special Provisions, Excel file scanned to two CD's)	<input type="checkbox"/>	<input type="checkbox"/>
<b>Job Warranty Letter</b> (Three Hardcopies & scanned to two CD's)	<input type="checkbox"/>	<input type="checkbox"/>
<b>Catalog Cut Submittals</b> -Approved & Approved as Noted (Scanned to two CD's)	<input type="checkbox"/>	<input type="checkbox"/>
<b>Lighting Inventory Form</b> (Three Hardcopies & scanned to two CD's)	<input type="checkbox"/>	<input type="checkbox"/>
<b>Lighting Controller Inventory Form</b> (Three Hardcopies & scanned to two CD's)	<input type="checkbox"/>	<input type="checkbox"/>
<b>Light Tower Inspection Form</b> (If applicable, Three Hardcopies & scanned to two CD's)	<input type="checkbox"/>	<input type="checkbox"/>

Three Hardcopies & scanned to two CD's shall be submitted for all items above. The CD ROM shall be labeled as shown in the example contained herein.

**General Notes:**

Record Drawings – The record drawings should contain contract cover sheet, summary of quantities showing all lighting pay item sheets, proposed lighting plans and lighting detail sheets. Submit hardcopies shall be 11” x 17” size. Temporary lighting plans and removal lighting plans should not be part of the set.

Field Inspection Tests – Testing should be done for proposed cables. Testing shall be per standard specifications. Forms shall be neatly filled out.

GPS Coordinates – Check special provisions “General Electrical Requirements”. Submit electronic “EXCEL” file.

Job Warranty Letter – See standard specifications.

Cutsheet Submittal – See special provisions “General Electrical Requirements”. Scan Approved and Approved as Noted cutsheets.

Lighting Inventory Form – Inventory form should include only proposed light poles, proposed light towers, proposed combination (traffic/light pole) lighting and proposed underpass luminaires.

Lighting Controller Inventory Form – Form should be filled out for only proposed lighting controllers.

Light Tower Safety Inspection Form – Form should be filled out for each proposed light tower.

CD LABEL FORMAT TEMPLATE.

**Label must be printed; hand written labels are unacceptable and will be rejected.**

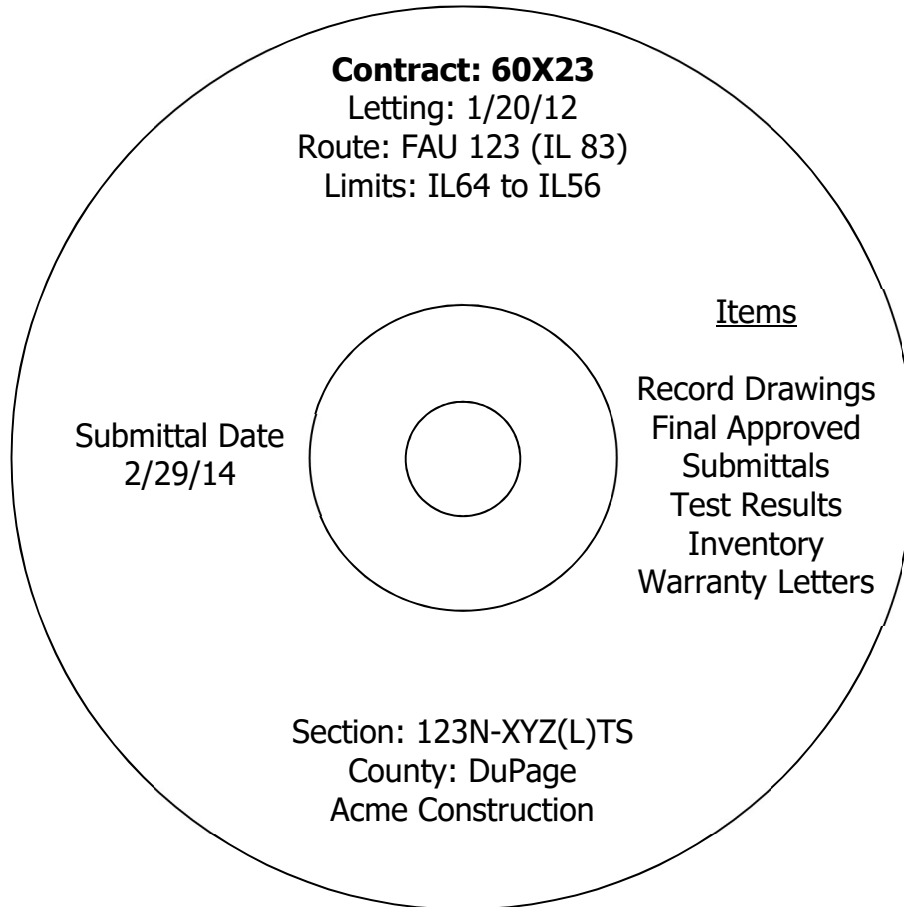

## **UNDERGROUND RACEWAYS**

Effective: March 1, 2015

Revise Article 810.04 of the Standard Specifications to read:

“Installation. All underground conduits shall have a minimum depth of 30-inches (700 mm) below the finished grade.”

Add the following to Article 810.04 of the Standard Specifications:

“All metal conduit installed underground shall be Rigid Steel Conduit unless otherwise indicated on the plans.”

Add the following to Article 810.04 of the Standard Specifications:

“All raceways which extend outside of a structure or duct bank but are not terminated in a cabinet, junction box, pull box, handhole, post, pole, or pedestal shall extend a minimum of 300 mm (12”) or the length shown on the plans beyond the structure or duct bank. The end of this extension shall be capped and sealed with a cap designed for the conduit to be capped.

The ends of rigid metal conduit to be capped shall be threaded, the threads protected with full galvanizing, and capped with a threaded galvanized steel cap.

The ends of rigid nonmetallic conduit and coilable nonmetallic conduit shall be capped with a rigid PVC cap of not less than 3 mm (0.125”) thick. The cap shall be sealed to the conduit using a room-temperature-vulcanizing (RTV) sealant compatible with the material of both the cap and the conduit. A washer or similar metal ring shall be glued to the inside center of the cap with epoxy, and the pull cord shall be tied to this ring.”

Add the following to Article 810.04 of the Standard Specifications:

“For UNDERGROUND CONDUIT, COILABLE NONMETALLIC CONDUIT, 2” DIA. as shown on the Intelligent Transportation System (ITS) plans, the Contractor shall proof the conduit in the presence of the Engineer by pulling through a bullnose aluminum mandrel of 1.62 inch diameter and length between 2.4 and 6.0 inches. Any breaks in the duct line shall be excavated and repaired at the Contractor’s expense, and the proofing test repeated. The Contractor shall also install a 5/8 inch woven polyester toneable pull tape with a minimum tensile strength of 1200 lbs.-force. All pull tapes shall have six (6) feet of extra slack extending from each end of the conduit and shall be secured before conduit ends are plugged.”

## **EXPOSED RACEWAYS**

Effective: January 1, 2012

Revise the first paragraph of Article 811.03(a) of the Standard Specifications to read:

“General. Rigid metal conduit installation shall be according to Article 810.05(a). Conduits terminating in junction and pull boxes shall be terminated with insulated and gasketed watertight threaded NEMA 4X conduit hubs. The hubs shall be Listed under UL 514B. The insulated throat shall be rated up to 105° C. When PVC coated conduit is utilized, the aforementioned hubs shall also be PVC coated.”

Add the following to Article 811.03(b) of the Standard Specifications:

“Where PVC coated conduit is utilized, all conduit fittings, couplings and clamps shall be PVC coated. All other mounting hardware and appurtenances shall be stainless steel.”

“The personnel installing the PVC coated conduit must be trained and certified by the PVC coated conduit Manufacturer or Manufacturer’s representative to install PVC coated conduit. Documentation demonstrating this requirement must be submitted for review and approval.”

Add the following to Article 1088.01(a) of the Standard Specifications:

All iron and steel products, which are to be incorporated into the work, including conduit and all conduit fittings, shall be domestically manufactured or produced and fabricated as specified in Article 106.”

Revise Article 1088.01(a)(3) of the Standard Specifications to read:

“a. PVC Coated Steel Conduit. The PVC coated rigid metal conduit shall be UL Listed (UL 6). The PVC coating must have been investigated by UL as providing the primary corrosion protection for the rigid metal conduit. Ferrous fittings for general service locations shall be UL Listed with PVC as the primary corrosion protection. Hazardous location fittings, prior to plastic coating shall be UL listed.

- b. The PVC coating shall have the following characteristics:

Hardness:	85+ Shore A Durometer
Dielectric Strength:	400V/mil @ 60 Hz
Aging:	1,000 Hours Atlas Weatherometer
Temperature	The PVC compound shall conform at 0° F. to Federal Specifications PL-406b, Method 2051, Amendment 1 of 25 September 1952 (ASTM D 746)
Elongation:	200%

- c. The exterior and interior galvanized conduit surface shall be chemically treated to enhance PVC coating adhesion and shall also be coated with a primer before the PVC coating to ensure a bond between the zinc substrate and the PVC coating. The bond strength created shall be greater than the tensile strength of the plastic coating.
- d. The nominal thickness of the PVC coating shall be 1 mm (40 mils). The PVC exterior and urethane interior coatings applied to the conduit shall afford sufficient flexibility to permit field bending without cracking or flaking at temperatures above -1°C (30°F).
- e. An interior urethane coating shall be uniformly and consistently applied to the interior of all conduit and fittings. This internal coating shall be a nominal 2 mil thickness. The interior coating shall be applied in a manner so there are no runs, drips, or pinholes at any point. The coating shall not peel, flake, or chip off after a cut is made in the conduit or a scratch is made in the coating.
- f. Conduit bodies shall have a tongue-in-groove gasket for maximum sealing capability. The design shall incorporate a positive placement feature to assure proper installation. Certified test results confirming seal performance at 15 psig (positive) and 25 in. of mercury (vacuum) for 72 hours shall be submitted for review when requested by the Engineer.

- g. The PVC conduit shall pass the following tests:

Exterior PVC Bond test RN1:

Two parallel cuts 13 mm (1/2 inch) apart and 40 mm (1 1/2 inches) in length shall be made with a sharp knife along the longitudinal axis. A third cut shall be made perpendicular to and crossing the longitudinal cuts at one end. The knife shall then be worked under the PVC coating for 13 mm (1/2 inch) to free the coating from the metal.

Using pliers, the freed PVC tab shall be pulled with a force applied vertically and away from the conduit. The PVC tab shall tear rather than cause any additional PVC coating to separate from the substrate.

Boil Test:

Acceptable conduit coating bonds (exterior and interior) shall be confirmed if there is no disbondment after a minimum average of 200 hours in boiling water or exposure to steam vapor at one atmosphere. Certified test results from a national recognized independent testing laboratory shall be submitted for review and approval. The RN1 Bond Test and the Standard Method for Measuring Adhesion by Tape Test shall be utilized.

Exterior Adhesion. In accordance with ASTM D870, a 6" length of conduit test specimen shall be placed in boiling water. The specimen shall be periodically removed, cooled to ambient temperature and immediately tested according to the bond test (RN1). When the PVC coating separates from the substrate, the boil time to failure in hours shall be recorded.

Interior Adhesion. In accordance with ASTM D3359, a 6" conduit test specimen shall be cut in half longitudinally and placed in boiling water or directly above boiling water with the urethane surface facing down. The specimen shall be periodically removed, cooled to ambient temperature and tested in accordance with the Standard Method of Adhesion by Tape Test (ASTM D3359). When the coating disbonds, the time to failure in hours shall be recorded.

Heat/Humidity Test:

Acceptable conduit coating bonds shall be confirmed by a minimum average of 30 days in the Heat and Humidity Test. The RN1 Bond Test and the Standard Method for Measuring Adhesion by Tape Test shall be utilized.

Exterior Adhesion. In accordance with ASTM D1151, D1735, D2247 and D4585, conduit specimens shall be placed in a heat and humidity environment where the temperature is maintained at 150°F (66°C) and 95% relative humidity. The specimens shall be periodically removed and a bond test (RN1) performed. When the PVC coating separates from the substrate, the exposure time to failure in days shall be recorded.

Interior Adhesion. In accordance with ASTM D3359, conduit specimens shall be placed in a heat and humidity environment where the temperature is maintained at 150°F (66°C) and 95% relative humidity. When the coating disbonds, the time to failure in hours shall be recorded.

Add the following to Article 1088.01(a)(4) of the Standard Specifications:

“All liquid tight flexible metal conduit fittings shall have an insulated throat to prevent abrasion of the conductors and shall have a captive sealing O-ring gasket. The fittings shall be Listed under UL 514B. The insulated throat shall be rated up to 105° C.”

Revise the second paragraph of Article 811.04 of the Standard Specifications to read:

“Expansion fittings and LFNC will not be measured for payment.”

Revise Article 811.05 of the Standard Specifications to read:

“**811.05 Basis of Payment.** This work will be paid for at the contract unit price per meter (foot) for **CONDUIT ATTACHED TO STRUCTURE**, of the diameter specified, **RIGID GALVANIZED STEEL** or **CONDUIT ATTACHED TO STRUCTURE**, of the diameter specified, **RIGID GALVANIZED STEEL, PVC COATED.**”



**UNIT DUCT**

Effective: January 1, 2012

Revise the first paragraph of Article 810.04 to read:

“The unit duct shall be installed at a minimum depth of 30-inches (760 mm) unless otherwise directed by the Engineer.”

Revise Article 1088.01(c) to read:

“(c) Coilable Nonmetallic Conduit.

General:

The duct shall be a plastic duct which is intended for underground use and which can be manufactured and coiled or reeled in continuous transportable lengths and uncoiled for further processing and/or installation without adversely affecting its properties of performance. The duct shall be a plastic duct which is intended for underground use and can be manufactured and coiled or reeled in continuous transportable lengths and uncoiled for further processing and/or installation without adversely affecting its properties of performance.

The duct shall be made of high density polyethylene which shall meet the requirements of ASTM D 2447, for schedule 40. The duct shall be composed of black high density polyethylene meeting the requirements of ASTM D 3350, Class C, Grade P33. The wall thickness shall be in accordance with Table 2 for ASTM D 2447.

The duct shall be UL Listed per 651-B for continuous length HDPE coiled conduit. The duct shall also comply with NEC Article 354.100 and 354.120.

Submittal information shall demonstrate compliance with the details of these requirements.

Dimensions:

Duct dimensions shall conform to the standards listed in ASTM D2447. Submittal information shall demonstrate compliance with these requirements.

Nominal Size		Nominal I.D.		Nominal O.D.		Minimum Wall	
mm	in	mm	in	mm	in	mm	in
31.75	1.25	35.05	1.380	42.16	1.660	3.556 +0.51	0.140 +0.020
38.1	1.50	40.89	1.610	48.26	1.900	3.683 +0.51	0.145 +0.020

Nominal Size		Pulled Tensile	
mm	in	N	lbs
31.75	1.25	3322	747
38.1	1.50	3972	893

**Marking:**

As specified in NEMA Standard Publication No. TC-7, the duct shall be clearly and durably marked at least every 3.05 meters (10 feet) with the material designation (HDPE for high density polyethylene), nominal size of the duct and the name and/or trademark of the manufacturer.

**Performance Tests:**

Polyethylene Duct testing procedures and test results shall meet the requirements of UL 651. Certified copies of the test report shall be submitted to the Engineer prior to the installation of the duct. Duct crush test results shall meet or exceed the following requirements:

Duct Diameter		Min. force required to deform sample 50%	
mm	in	N	lbs
35	1.25	4937	1110
41	1.5	4559	1025

**WIRE AND CABLE**

Effective: January 1, 2012

Add the following to the first paragraph of Article 1066.02(a):

“The cable shall be rated at a minimum of 90°C dry and 75°C wet and shall be suitable for installation in wet and dry locations, and shall be resistant to oils and chemicals.”

Revise the Aerial Electric Cable Properties table of Article 1066.03(a)(3) to read:

Aerial Electric Cable Properties

Size AWG	Phase Conductor		Messenger wire		
	Stranding	Average Insulation Thickness	Minimum Size AWG	Stranding	
		mm	mils		
6	7	1.1	(45)	6	6/1
4	7	1.1	(45)	4	6/1
2	7	1.1	(45)	2	6/1
1/0	19	1.5	(60)	1/0	6/1
2/0	19	1.5	(60)	2/0	6/1
3/0	19	1.5	(60)	3/0	6/1
4/0	19	1.5	(60)	4/0	6/1

Add the following to Article 1066.03(b) of the Standard Specifications:

“Cable sized No. 2 AWG and smaller shall be U.L. listed Type RHH/RHW and may be Type RHH/RHW/USE. Cable sized larger than No. 2 AWG shall be U.L. listed Type RHH/RHW/USE.”

Revise Article 1066.04 to read:

“Aerial Cable Assembly. The aerial cable shall be an assembly of insulated aluminum conductors according to Section 1066.02 and 1066.03. Unless otherwise indicated, the cable assembly shall be composed of three insulated conductors and a steel reinforced bare aluminum conductor (ACSR) to be used as the ground conductor. Unless otherwise indicated, the code word designation of this cable assembly is “Palomino”. The steel reinforced aluminum conductor shall conform to ASTM B-232. The cable shall be assembled according to ANSI/ICEA S-76-474.”

Revise the second paragraph of Article 1066.05 to read:

“The tape shall have reinforced metallic detection capabilities consisting of a woven reinforced polyethylene tape with a metallic core or backing.”

## **ELECTRIC UTILITY SERVICE CONNECTION (COMED)**

Effective: January 1, 2012

**Description.** This item shall consist of payment for work performed by ComEd in providing or modifying electric service as indicated. THIS MAY INVOLVE WORK AT MORE THAN ONE ELECTRIC SERVICE. For summary of the Electrical Service Drop Locations see the schedule contained elsewhere herein.

## **CONSTRUCTION REQUIREMENTS**

**General.** It shall be the Contractor's responsibility to contact ComEd. The Contractor shall coordinate his work fully with the ComEd both as to the work required and the timing of the installation. No additional compensation will be granted under this or any other item for extra work caused by failure to meet this requirement. **Please contact ComEd, New Business Center Call Center, at 866 NEW ELECTRIC (1-866-639-3532) to begin the service connection process. The Call Center Representatives will create a work order for the service connection. The representative will ask the requestor for information specific to the request. The representative will assign the request based upon the location of project.**

The Contractor should make particular note of the need for the earliest attention to arrangements with ComEd for service. In the event of delay by ComEd, no extension of time will be considered applicable for the delay unless the Contractor can produce written evidence of a request for electric service within 30 days of execution.

**Method Of Payment.** The Contractor will be reimbursed to the exact amount of money as billed by ComEd for its services. Work provided by the Contractor for electric service will be paid separately as described under ELECTRIC SERVICE INSTALLATION. No extra compensation shall be paid to the Contractor for any incidental materials and labor required to fulfill the requirements as shown on the plans and specified herein.

For bidding purposes, this item shall be estimated as \$30,000.

**Basis Of Payment.** This work will be paid for at the contract lump sum price for **ELECTRIC UTILITY SERVICE CONNECTION** which shall be reimbursement in full for electric utility service charges.

## **ELECTRIC SERVICE INSTALLATION**

Effective: January 1, 2012

**Description.** This item shall consist of all material and labor required to extend, connect or modify the electric services, as indicated or specified, which is over and above the work performed by the utility. Unless otherwise indicated, the cost for the utility work, if any, will be reimbursed to the Contractor separately under ELECTRIC UTILITY SERVICE CONNECTION. This item may apply to the work at more than one service location and each will be paid separately.

**Materials.** Materials shall be in accordance with the Standard Specifications.

## **CONSTRUCTION REQUIREMENTS**

**General.** The Contractor shall ascertain the work being provided by the electric utility and shall provide all additional material and work not included by other contract pay items required to complete the electric service work in complete compliance with the requirements of the utility.

No additional compensation will be allowed for work required for the electric service, even though not explicitly shown on the Drawings or specified herein.

**Method Of Measurement.** Electric Service Installation shall be counted, each.

**Basis Of Payment.** This work will be paid for at the contract unit price each for **ELECTRIC SERVICE INSTALLATION** which shall be payment in full for the work specified herein.

## **ROADWAY LUMINAIRE, LED**

Effective: April 1, 2024

### Description.

This work shall consist of furnishing and installing a roadway LED luminaire as shown on the plans, as specified herein.

### General.

The luminaire including the housing, driver and optical assembly shall be assembled in the U.S.A. The luminaire shall be assembled by and manufactured by the same manufacturer. The luminaire shall be mechanically strong and easy to maintain. The size, weight, and shape of the luminaire shall be designed so as not to incite detrimental vibrations in its respective pole and it shall be compatible with the pole and arm. All electrical and electronic components of the luminaire shall comply with the requirements of Restriction of Hazardous Materials (RoHS) regulations. The luminaire shall be listed for wet locations by an NRTL and shall meet the requirements of UL 1598 and UL 8750

### Submittal Requirements.

The Contractor shall also submit the following manufacturer's product data for each type of luminaire:

1. Descriptive literature and catalogue cuts for luminaire, LED driver, and surge protection device. Completed manufacturer's luminaire ordering form with the full catalog number provided
2. LED drive current, total luminaire input wattage and total luminaire current at the system operating voltage or voltage range and ambient temperature of 25 C.
3. LED efficacy per luminaire expressed in lumens per watt (l/w).
4. Initial delivered lumens at the specified color temperature, drive current, and ambient
5. temperature.
6. IES file associated with each submitted luminaire in the IES LM-63 format.
7. Computer photometric calculation reports as specified and in the luminaire performance table.
8. TM-15 BUG rating report.
9. Isofootcandle chart with max candela point and half candela trace indicated.

10. Documentation of manufacturers experience and verification that luminaires were assembled in the U.S.A. as specified.

11. Written warranty.

Upon request by the Engineer, the submittals shall also include any or all the following:

- a. TM-21 calculator spreadsheet (XLSX or PDF format) and if available, TM-28 report for the specified luminaire or luminaire family. Both reports shall be for 50,000 hours at an ambient temperature of 77 °F (25 °C).
- b. LM-79 report with National Voluntary Laboratory Accreditation Program (NVLAP) current at the time of testing in PDF format inclusive of the following: isofootcandle diagram with half candela contour and maximum candela point; polar plots through maximum plane and maximum cone; coefficient of utilization graph; candela table; and spectral distribution graph and chromaticity diagram.
- c. LM-80 report for the specified LED package in PDF format and if available, LM-84 report for the specified luminaire or luminaire family in PDF format. Both reports shall be conducted by a laboratory with NVLAP certification current at the time of testing.
- d. AGi32 calculation file matching the submittal package.
- e. In Situ Temperature Measurement Test (ISTMT) report for the specified luminaire or luminaire family in PDF format.
- f. Vibration test report in accordance with ANSI C136.31 in PDF format.
- g. ASTM B117/ASTM D1654 (neutral salt spray) test and sample evaluation report in PDF format.
- h. ASTM G154 (ASTM D523) gloss test report in PDF format.
- i. LED drive current, total luminaire input wattage, and current over the operating voltage range at an ambient temperature of 77 °F (25 °C).
- j. Power factor (pf) and total harmonic distortion (THD) at maximum and minimum supply and at nominal voltage for the dimmed states of 70%, 50%, and 30% full power.
- k. Ingress protection (IP) test reports, conducted according to ANSI C136.25 requirements, for the driver and optical assembly in PDF format.
- l. Installation, maintenance, and cleaning instructions in PDF format, including recommendations on periodic cleaning methods.
- m. Documentation in PDF format that the reporting laboratory is certified to perform the required tests.

A sample luminaire shall also be provided upon request of the Engineer. The sample shall be as proposed for the contract and shall be delivered by the Contractor to the District Headquarters. After review, the Contractor shall retrieve the luminaire.

#### Manufacturer Experience.

The luminaire shall be designed to be incorporated into a lighting system with an expected 20 year lifetime. The luminaire manufacturer shall have a minimum of 15 years' experience manufacturing LED roadway luminaires; parking lot, architectural, or residential luminaires are not applicable to this requirement. The manufacturer shall have a minimum of 100,000 total LED roadway luminaires installed on a minimum of 100 separate installations, all within the U.S.A.

#### Housing.

Material. The luminaire shall be a single device not requiring on-site assembly for installation. The driver for the luminaire shall be integral to the unit.

Finish. The luminaire shall have a baked acrylic enamel finish. The color of the finish shall be gray, unless otherwise indicated.

The finish shall have a rating of six or greater according to ASTM D1654, Section 8.0 Procedure A – Evaluation of Rust Creepage for Scribed Samples after exposure to 1000 hours of testing according to ASTM B117 for painted or finished surfaces under environmental exposure.

The luminaire finish shall have less than or equal to 30% reduction of gloss according to ASTM D523 after exposure of 500 hours to ASTM G154 Cycle 6 QUV® accelerated weathering testing.

The luminaire shall slip-fit on a mounting arm with a 2" diameter tenon (2.375" outer diameter), and shall have a barrier to limit the amount of insertion. The slip fitter clamp shall utilize four (4) bolts to clamp to the tenon arm. The luminaire shall be provided with a leveling surface and shall be capable of being tilted  $\pm 5$  degrees from the axis of attachment in 2.5 degree increments and rotated to any degree with respect to the supporting arm.

All external surfaces shall be cleaned in accordance with the manufacturer's recommendations and be constructed in such a way as to discourage the accumulation of water, ice, and debris.

The effective projected area of the luminaire shall not exceed 1.6 sq. ft.

The total weight including accessories, shall not exceed 40 lb (18.14 kg).

A passive cooling method with no moving, rotating parts, or liquids shall be employed for heat management.

The luminaire shall include a fully prewired, 7-pin twist lock ANSI C136.41-compliant receptacle. Unused pins shall be connected as directed by the Manufacturer and as approved by the Engineer. A shorting cap shall be provided with the luminaire that is compliant with ANSI C136.10.

Vibration Testing. All luminaires shall be subjected to and pass vibration testing requirements at “3G” minimum zero to peak acceleration in accordance with ANSI C136.31 requirements using the same luminaire. To be accepted, the luminaire housing, hardware, and each individual component shall pass this test with no noticeable damage and the luminaire must remain fully operational after testing.

Labels. An internal label shall be provided indicating the luminaire is suitable for wet locations and indicating the luminaire is an NRTL listed product to UL1598 and UL8750. The internal label shall also comply with the requirements of ANSI C136.22.

An external label consisting of two black characters on a white background with the dimensions of the label and the characters as specified in ANSI C136.15 for HPS luminaires. The first character shall be the alphabetical character representing the initial lumen output as specified in Table 1 of Article 1067.06(c). The second character shall be the numerical character representing the transverse light distribution type as specified in IES RP-8 (i.e. Types 1, 2, 3, 4, or 5).

Hardware. All hardware shall be stainless steel or of other corrosion resistant material approved by the Engineer.

Luminaires shall be designed to be easily serviced, having fasteners such as quarter-turn clips of the heavy spring-loaded type with large, deep straight slot heads, complete with a receptacle and shall be according to military specification MIL-f-5591.

All hardware shall be captive and not susceptible to falling from the luminaire during maintenance operations. This shall include lens/lens frame fasteners as well hardware holding the removable driver and electronic components in place.

Provisions for any future house-side external or internal shielding should be indicated along with means of attachment.

Circuiting shall be designed to minimize the impact of individual LED failures on the operation of the other LED's.

Wiring. Wiring within the electrical enclosure shall be rated at 600v, 105°C or higher.

#### Driver.

The driver shall be integral to the luminaire shall be capable of receiving an indefinite open and short circuit output conditions without damage.

The driver shall incorporate the use of thermal foldback circuitry to reduce output current under abnormal driver case temperature conditions and shall be rated for a lifetime of 100,000 hours at an ambient temperature exposure of 77 °F (25 °C) to the luminaire. If the driver has a thermal shut down feature, it shall not turn off the LEDs when operated at 104 °F (40 °C) or less.



The driver shall have an input voltage range of 120 to 277 volts ( $\pm 10\%$ ) or 347 to 480 volts ( $\pm 10\%$ ) according to the contract documents. When the driver is operating within the rated input voltage range and in an un-dimmed state, the power factor measurement shall be not less than 0.9 and the THD measurement shall be no greater than 20%.

The driver shall meet the requirements of the FCC Rules and Regulations, Title 47, Part 15 for Class A devices with regard to electromagnetic compatibility. This shall be confirmed through the testing methods in accordance with ANSI C63.4 for electromagnetic interference.

The driver shall be dimmable using the protocol listed in the Luminaire Performance Table shown in the contract.

Surge Protection. The luminaire shall comply the requirements of ANSI C136.2 for electrical transient immunity at the "Extreme" level (20KV/10KA) and shall be equipped with a surge protective device (SPD) that is UL1449 compliant with indicator light. An SPD failure shall open the circuit to protect the driver.

#### LED Optical Assembly

The optical assembly shall have an IP 65 or higher rating in accordance with ANSI C136.25. The circuiting of the LED array shall be designed to minimize the effect of individual LED failures on the operation of other LEDs. All optical components shall be made of glass or a UV stabilized, non-yellowing material.

The optical assembly shall utilize high brightness, long life, minimum 70 CRI, 4,000K color temperature ( $\pm 300K$ ) LEDs binned in accordance with ANSI C78.377. Lenses shall be UV-stabilized acrylic or glass.

Lumen depreciation at 50,000 hours of operation shall not exceed 15% of initial lumen output at the specified LED drive current and an ambient temperature of 25° C.

The luminaire may or may not have a glass lens over the LED modules. If a glass lens is used, it must be a flat lens. Material other than glass will not be acceptable. If a glass lens is not used, the LED modules may not protrude lower than the luminaire housing.

The assembly shall have individual serial numbers or other means for manufacturer tracking.

#### Photometric Performance.

Luminaires shall be tested according to IESNA LM-79. This testing shall be performed by a test laboratory holding accreditation from the National Institute of Standards and Technology (NIST) National Voluntary Laboratory Accreditation Program (NVLAP) for the IESNA LM-79 test procedure.

Data reports as a minimum shall yield an isofootcandle chart, with max candela point and half candela trace indicated, maximum plane and maximum cone plots of candela, a candlepower table (house and street side), a coefficient of utilization chart, a luminous flux distribution table, spectral distribution plots, chromaticity plots, and other standard report outputs of the above mentioned tests.

The luminaire shall have a BUG rating of Back Light B3 or less, Up Light rating of U0, and a Glare rating of G3 or less unless otherwise indicated in the luminaire performance table.

#### Photometric Calculations.

Calculations. Submitted report shall include a luminaire classification system graph with both the recorded lumen value and percent lumens by zone along with the BUG rating according to IESNA TM-15.

Complete point-by-point luminance and veiling luminance calculations as well as listings of all indicated averages and ratios as applicable shall be provided in accordance with IESNA RP-8 recommendations. Lighting calculations shall be performed using AGi32 software with all luminance calculations performed to one decimal place (i.e. x.x cd/m<sup>2</sup>). Uniformity ratios shall also be calculated to one decimal place (i.e. x.x:1). Calculation results shall demonstrate that the submitted luminaire meets the lighting metrics specified in the project Luminaire Performance Table(s). Values shall be rounded to the number of significant digits indicated in the luminaire performance table(s).

All photometry must be **photopic**. Scotopic or mesopic factors will not be allowed. The AGi32 file shall be submitted at the request of the Engineer.

**IDOT DISTRICT 1 LUMINAIRE PERFORMANCE TABLE  
 ROADWAY LIGHTING**

**GIVEN CONDITIONS**

Roadway Data	Pavement Width	16	Ft
	Number of Lanes Left of Median	1	
	Number of Lanes Right of Median	N/A	
	Lane Width	16	Ft
	Median Width	N/A	Ft
	IES Surface Classification	R3	
	Q-Zero Value	0.07	
Mounting Data	Mounting Height	47.5	Ft
	Mast Arm Length	15	Ft
	Pole Set-Back from Edge of Pavement	19	Ft
Luminaire Data	Source	LED	
	Color Temperature	4000	°K
	Lumens	25,200	Min
	Pay Item Lumen Designation	H	
	BUG Rating	B3/B4-U0-G3	
	IES Vertical Distribution	Medium	
	IES Control of Distribution	Cutoff	
	IES Lateral Distribution	Type 2	
	Total Light Loss Factor	0.70	
Pole Layout Data	Spacing	300	Ft
	Configuration	Single Sided	
	Luminaire Overhang over E.O.P.	-4	Ft

**NOTE:** Variations from the above specified I.E.S. distribution pattern may be requested, and acceptance of variations will be subject to review by the Engineer based on how well the performance requirements are met.

**PERFORMANCE REQUIREMENTS**

**NOTE:** These performance requirements shall be the minimum acceptable standards of photometric performance for the luminaire, based on the given conditions listed above.

Roadway Luminance	Average Luminance, $L_{AVE}$ (Max)	1.2	Cd/m <sup>2</sup>
	Average Luminance, $L_{AVE}$ (Min)	0.8	Cd/m <sup>2</sup>
	Uniformity Ratio, $L_{AVE}/L_{MIN}$	3.0	Max
	Uniformity Ratio, $L_{MAX}/L_{MIN}$	5.0	Max
	Veiling Luminance Ratio, $L_V/L_{AVE}$	0.3	Max

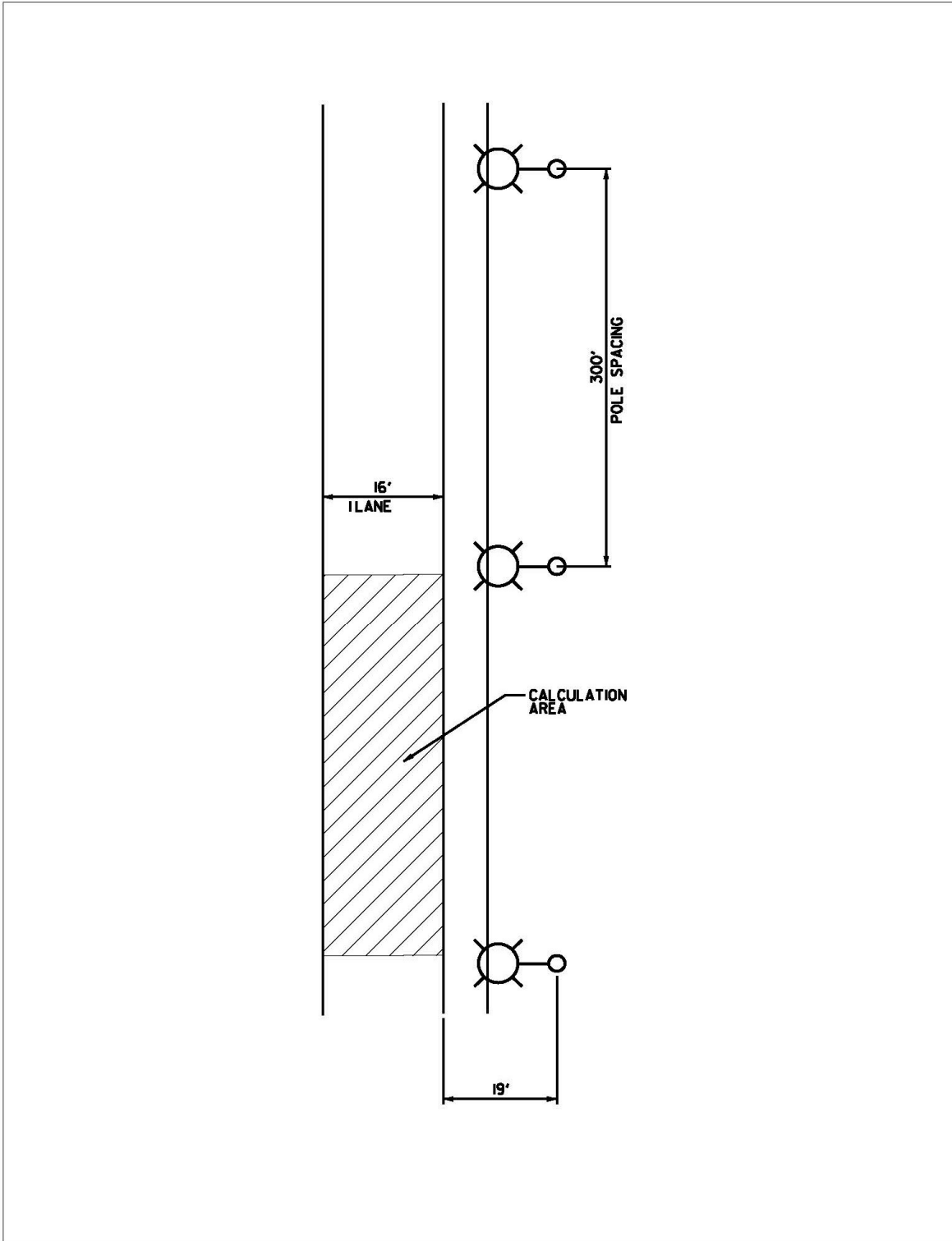

Independent Testing

When a contract has 50 or more luminaires of the same type (distribution type and lumen output/wattage), that luminaire type shall be independently tested, unless otherwise noted. The quantity of luminaires to be tested shall be as specified in the following table.

<b>Contract Quantity</b>	<b>Luminaires to be Tested</b>
1-49	0 (unless otherwise noted)
50-100	2
101-150	3
151-200	4
201-250	5
251-300	6
301-350	7

The Contractor shall coordinate the testing with the contract schedule considering submittal, manufacturing, testing, and installation lead-times and deadlines.

The Electrical Engineer shall select from all the project luminaires at the Contractor's or distributor's storage facility, within District 1, the luminaires for testing. In all cases, the selection of luminaires shall be a random selection from the entire completed lot of luminaires required for the contract. Selections from partial lots will not be allowed. An additional luminaire shall also be selected for physical inspection by the Engineer at the District Headquarters. This luminaire will be available for the Contractor to pick up at a later date to be installed under this contract. This luminaire is in addition to the luminaire required as a part of the submittal process specified elsewhere.

Alternative selection process. With the Engineer's prior approval, the Contractor shall provide a list of luminaire serial numbers for all the luminaires. The Engineer shall make a random selection of the required number of luminaires for testing from the serial numbers. That luminaire must then be photographed clearly showing the serial number prior to shipment to the selected and approved testing laboratory. The testing laboratory shall include a photograph of the luminaire along with the test results directly to the Engineer.

Luminaires shall be tested at a National Voluntary Laboratory Accreditation Program (NVLAP) accredited laboratory approved for each of the required tests. The testing facility shall not be associated in any way, subsidiary or otherwise, with the luminaire manufacturer. All costs associated with luminaire testing shall be included in the bid price of the luminaire.

The selection of the proposed independent laboratory shall be presented with the information submitted for review and approval.

The testing performed shall include photometric and electrical testing.

**All tests shall be conducted at the luminaire system operating voltage of 240 volts unless specified differently in the contract plans.**

Photometric testing shall be according to IES recommendations, performed with a goniophotometer and as a minimum, shall yield an isofootcandle chart, with max candela point and half candela trace indicated, an isocandela diagram, maximum planned and maximum cone plots of candela, a candlepower table (House and street side), a coefficient of utilization chart, a luminous flux distribution table, BUG rating report, and complete calculations based on specified requirements and test results.

Electrical testing shall conform to NEMA and ANSI standards and, as a minimum shall include a complete check of wiring connections and a table of characteristics showing input amperes, watts, power factor, total harmonic distortion and LED drive current.

The summary report and the test results including IES photometric files shall be sent directly to the Resident Engineer, the Electrical Engineer, and the Contractor via email or other mutually agreeable means.

Photometric performance shall meet or exceed that of the specified values. If the luminaire does not meet the specified photometric values, the luminaire has failed regardless of whether the test results meet the submitted factory data.

Should any of the tested luminaires of a given type, and distribution fail to satisfy the specifications and perform according to approved submittal information, the luminaire type of that distribution type and wattage shall be unacceptable and be replaced by alternate equipment meeting the specifications with the submittal and testing process repeated in their entirety; or corrections made to achieve required performance.

In the case of corrections, the Contractor shall advise the Engineer of the proposed corrections and shall request a repeat of the specified testing and, if the corrections are deemed reasonable by the Engineer, the testing process shall be repeated in its entirety.

The number of luminaires to be tested shall be the same quantity as originally tested as required in the above table.

Retesting, should it become necessary, shall not be grounds for additional compensation or extension of time.

Submittal information shall include a statement of intent to provide the testing as well as a request for approval of the chosen laboratory.

### Installation.

Each luminaire shall be installed according to the luminaire manufacturer's recommendations.

Luminaires which are pole mounted shall be mounted on site such that poles and arms are not left unloaded. Pole mounted luminaires shall be leveled/adjusted after poles are set and vertically aligned before being energized. When mounted on a tenon, care shall be exercised to assure maximum insertion of the mounting tenon. Each luminaire shall be checked to assure compatibility with the project power system. When the night-time check of the lighting system by the Engineer indicates that any luminaires are mis-aligned, the mis-aligned luminaires shall be corrected at no additional cost.

No luminaire shall be installed prior to approval. Where independent testing is required, full approval will not be given until complete test results, demonstrating compliance with the specifications, have been reviewed and accepted by the Engineer.

Pole wiring shall be provided with the luminaire. Pole wire shall run from handhole to luminaire. Pole wire shall be sized No. 10, rated 600 V, RHW/USE-2, and have copper conductors, stranded in conformance with ASTM B 8. Pole wire shall be insulated with cross-linked polyethylene (XLP) insulation. Pole wire shall include a phase, neutral, and green ground wire. Wire shall be trained within the pole or sign structure so as to avoid abrasion or damage to the insulation.

Pole wire shall be extended through the pole, pole grommet, luminaire ring, and any associated arm and tenon. The pole wire shall be terminated in a manner that avoids sharp kinks, pinching, pressure on the insulation, or any other arrangement prone to damaging insulation value and producing poor megger test results. Wires shall be trained away from heat sources within the luminaire. Wires shall be terminated so all strands are extended to the full depth of the terminal lug with the insulation removed far enough so it abuts against the shoulder of the lug, but is not compressed as the lug is tightened.

Included with the pole wiring shall be fusing located in the handhole. Fusing shall be according to Article 1065.01 with the exception that fuses shall be 6 amperes.

Each luminaire and optical assembly shall be free of all dirt, smudges, etc. Should the optical assembly require cleaning, a luminaire manufacturer approved cleaning procedure shall be used.

Horizontal mount luminaires shall be installed in a level, horizontal plane, with adjustments as needed to insure the optics are set perpendicular to the traveled roadway.

When the pole is bridge mounted, a minimum size stainless steel 1/4-20NC set screw shall be provided to secure the luminaire to the mast arm tenon. A hole shall be drilled and tapped through the tenon and luminaire mounting bracket and then fitted with the screw.

Warranty.

The entire luminaire and all of its component parts shall be covered by a 10-year warranty. Failure is when one or more of the following occur:

- 1) Negligible light output from more than 10 percent of the discrete LEDs.
- 2) Significant moisture that deteriorates performance of the luminaire.
- 3) Driver that continues to operate at a reduced output due to overheating.

**The warranty period shall begin on the date of luminaire delivery.** The Contractor shall verify that the Resident Engineer has noted the delivery date in the daily diary. Copy of the shipment and delivery documentation shall be submitted with the final documentation.

The replacement luminaire shall be of the same manufacturer, model, and photometric distribution as the original.

Method of Measurement.

The rated initial minimum luminous flux (lumen output) of the light source, as installed in the luminaire, shall be according to the following table for each specified output designation.

<b>Designation Type</b>	<b>Minimum Initial Luminous Flux</b>	<b>Designation Type</b>	<b>Minimum Initial Luminous Flux</b>
A	2,200	F	12,500
B	3,150	G	15,500
C	4,400	H	25,200
D	6,300	I	33,000
E	9,450		

Where delivered lumens is defined as the minimum initial delivered lumens at the specified color temperature. Luminaires with an initial luminous flux less than the values listed in the above table will not be acceptable even if they meet the requirements given in the Luminaire Performance table shown in the contract.

Basis of Payment.

This work will be paid for at the contract unit price per each for **LUMINAIRE, LED, ROADWAY,** of the output designation specified.



## **TEMPORARY LUMINAIRE, LED, ROADWAY**

Effective: November 1, 2023

### Description.

This work shall consist of furnishing and installing a temporary roadway LED luminaire as shown on the plans, as specified herein.

### General.

In order to expedite the roadway work, the luminaire may be new or previously used. **The luminaire shall be of the output designation specified and the distribution pattern specified in the plans.**

The luminaire shall remain the property of the Contractor.

The luminaire shall be listed for wet locations by an NRTL and shall meet the requirements of UL 1598 and UL 8750

Used luminaires shall be no older than five years old. Documentation shall be submitted to verify compliance with this requirement.

### Submittal Requirements.

The Contractor shall submit manufacturer's product data for each type of luminaire including descriptive literature and catalogue cuts.

A sample luminaire shall also be provided upon request of the Engineer. The sample shall be as proposed for the contract and shall be delivered by the Contractor to the District Headquarters. After review, the Contractor shall retrieve the luminaire.

### Housing.

The luminaire shall slip-fit on a mounting arm with a 2" diameter tenon (2.375" outer diameter). The luminaire shall be provided with a leveling surface and shall be capable of being tilted  $\pm 5$  degrees from the axis of attachment in 2.5 degree increments and rotated to any degree with respect to the supporting arm.

An external label consisting of two black characters on a white background with the dimensions of the label and the characters as specified in ANSI C136.15 for HPS luminaires. The first character shall be the alphabetical character representing the initial lumen output as specified in Table 1 of Article 1067.06(c). The second character shall be the numerical character representing the transverse light distribution type as specified in IES RP-8 (i.e. Types 1, 2, 3, 4, or 5).

Wiring. Wiring within the electrical enclosure shall be rated at 600v, 105°C or higher.

Driver.

The driver shall have an input voltage range of 120 to 277 volts ( $\pm 10\%$ ) or 347 to 480 volts ( $\pm 10\%$ ) according to the contract documents.

The driver shall meet the requirements of the FCC Rules and Regulations, Title 47, Part 15 for Class A devices with regard to electromagnetic compatibility. This shall be confirmed through the testing methods in accordance with ANSI C63.4 for electromagnetic interference.

Surge Protection. The luminaire shall comply the requirements of ANSI C136.2 for electrical transient immunity at the "Extreme" level (20KV/10KA) and shall be equipped with a surge protective device (SPD) that is UL1449 compliant with indicator light. An SPD failure shall open the circuit to protect the driver.

Installation.

Each luminaire shall be installed according to the luminaire manufacturer's recommendations.

Luminaires which are pole mounted shall be mounted on site such that poles and arms are not left unloaded. Pole mounted luminaires shall be leveled/adjusted after poles are set and vertically aligned before being energized. When mounted on a tenon, care shall be exercised to assure maximum insertion of the mounting tenon. Each luminaire shall be checked to assure compatibility with the project power system. When the night-time check of the lighting system by the Engineer indicates that any luminaires are mis-aligned, the mis-aligned luminaires shall be corrected at no additional cost.

No luminaire shall be installed prior to approval.

Pole wiring shall be provided with the luminaire. Pole wire shall run from handhole to luminaire. Pole wire shall be sized No. 10, rated 600 V, RHW/USE-2, and have copper conductors, stranded in conformance with ASTM B 8. Pole wire shall be insulated with cross-linked polyethylene (XLP) insulation. Pole wire shall include a phase, neutral, and green ground wire. Wire shall be trained within the pole or sign structure so as to avoid abrasion or damage to the insulation.

Pole wire shall be extended through the pole, pole grommet, luminaire ring, and any associated arm and tenon. The pole wire shall be terminated in a manner that avoids sharp kinks, pinching, pressure on the insulation, or any other arrangement prone to damaging insulation value and producing poor megger test results. Wires shall be trained away from heat sources within the luminaire. Wires shall be terminated so all strands are extended to the full depth of the terminal lug with the insulation removed far enough so it abuts against the shoulder of the lug, but is not compressed as the lug is tightened.

Included with the pole wiring shall be fusing located in the handhole. Fusing shall be according to Article 1065.01 with the exception that fuses shall be 6 amperes.

Each luminaire and optical assembly shall be free of all dirt, smudges, etc. Should the optical assembly require cleaning, a luminaire manufacturer approved cleaning procedure shall be used.

Horizontal mount luminaires shall be installed in a level, horizontal plane, with adjustments as needed to ensure the optics are set perpendicular to the traveled roadway.

When the pole is bridge mounted, a minimum size stainless steel 1/4-20NC set screw shall be provided to secure the luminaire to the mast arm tenon. A hole shall be drilled and tapped through the tenon and luminaire mounting bracket and then fitted with the screw.

Method of Measurement.

The rated initial minimum luminous flux (lumen output) of the light source, as installed in the luminaire, shall be according to the following table for each specified output designation.

Designation Type	Minimum Initial Luminous Flux	Designation Type	Minimum Initial Luminous Flux
A	2,200	G	15,500
B	3,150	H	25,200
C	4,400	I	47,250
D	6,300	J	63,300
E	9,450	K	80,000+
F	12,500		

Where delivered lumens is defined as the minimum initial delivered lumens at the specified color temperature. Luminaires with an initial luminous flux less than the values listed in the above table will not be acceptable.

Basis of Payment.

This work will be paid for at the contract unit price per each for **TEMPORARY LUMINAIRE, LED, ROADWAY**, of the output designation specified.

## **HIGHMAST LUMINAIRE, LED**

Effective: April 1, 2024

### Description.

This work shall consist of furnishing and installing a highmast LED luminaire as shown on the plans, as specified herein.

### General.

The luminaire including the housing, driver and optical assembly shall be assembled in the U.S.A. The luminaire shall be assembled by and manufactured by the same manufacturer. The luminaire shall be mechanically strong and easy to maintain. The size, weight, and shape of the luminaire shall be designed so as not to incite detrimental vibrations in its respective structure and it shall be compatible with the mounting arm. All electrical and electronic components of the luminaire shall comply with the requirements of Restriction of Hazardous Materials (RoHS) regulations. The luminaire shall be listed for wet locations by an NRTL and shall meet the requirements of UL 1598 and UL 8750.

The luminaire shall be designed and manufactured for high mast tower use. It shall be designed to withstand constant 80 mph (130 km/hr) wind speeds and 104 mph (167 km/hr) gusts and the physical stresses associated with such duty including shocks and vibrations.

### Submittal Requirements.

The Contractor shall also the following manufacturer's product data for each type of luminaire:

1. Descriptive literature and catalogue cuts for luminaire, LED driver, and surge protection device. Completed manufacturer's luminaire ordering form with the full catalog number provided
2. LED drive current, total luminaire input wattage and total luminaire current at the system operating voltage or voltage range and ambient temperature of 25 C.
3. LED efficacy per luminaire expressed in lumens per watt (l/w).
4. Initial delivered lumens at the specified color temperature, drive current, and ambient temperature.
5. IES file associated with each submitted luminaire in the IES LM-63 format.
6. Computer photometric calculation reports as specified and in the luminaire performance table.

7. TM-15 BUG rating report.
8. Isofootcandle chart with max candela point and half candela trace indicated.
9. Documentation of manufacturers experience and verification that luminaires were assembled in the U.S.A. as specified.
10. Written warranty.

Upon request by the Engineer, submittals shall also include any or all the following:

- a. TM-21 calculator spreadsheet (XLSX or PDF format) and if available, TM-28 report for the specified luminaire or luminaire family. Both reports shall be for 50,000 hours at an ambient temperature of 77 °F (25 °C).
- b. LM-79 report with National Voluntary Laboratory Accreditation Program (NVLAP) current at the time of testing in PDF format inclusive of the following: isofootcandle diagram with half candela contour and maximum candela point; polar plots through maximum plane and maximum cone; coefficient of utilization graph; candela table; and spectral distribution graph and chromaticity diagram.
- c. LM-80 report for the specified LED package in PDF format and if available, LM-84 report for the specified luminaire or luminaire family in PDF format. Both reports shall be conducted by a laboratory with NVLAP certification current at the time of testing.
- d. AGi32 calculation file matching the submittal package.
- e. In Situ Temperature Measurement Test (ISTMT) report for the specified luminaire or luminaire family in PDF format.
- f. Vibration test report in accordance with ANSI C136.31 in PDF format.
- g. ASTM B117/ASTM D1654 (neutral salt spray) test and sample evaluation report in PDF format.
- h. ASTM G154 (ASTM D523) gloss test report in PDF format.
- i. LED drive current, total luminaire input wattage, and current over the operating voltage range at an ambient temperature of 77 °F (25 °C).
- j. Power factor (pf) and total harmonic distortion (THD) at maximum and minimum supply and at nominal voltage for the dimmed states of 70%, 50%, and 30% full power.

- k. Ingress protection (IP) test reports, conducted according to ANSI C136.25 requirements, for the driver and optical assembly in PDF format.
- l. Installation, maintenance, and cleaning instructions in PDF format, including recommendations on periodic cleaning methods.
- m. Documentation in PDF format that the reporting laboratory is certified to perform the required tests.

A sample luminaire shall also be provided upon request of the Engineer. The sample shall be as proposed for the contract and shall be delivered by the Contractor to the District Headquarters. After review, the Contractor shall retrieve the luminaire.

#### Manufacturer Experience.

The luminaire shall be designed to be incorporated into a lighting system with an expected 20 year lifetime. The luminaire manufacturer shall have a minimum of 15 years' experience manufacturing LED roadway luminaires; parking lot, architectural, or residential luminaires are not applicable to this requirement. The manufacturer shall have a minimum of 100,000 total LED roadway luminaires installed on a minimum of 100 separate installations, all within the U.S.A.

#### Housing.

**Material.** The luminaire shall be a single device not requiring on-site assembly for installation. The driver for the luminaire shall be integral to the unit.

**Finish.** The luminaire shall have a baked acrylic enamel finish. The color of the finish shall be gray, unless otherwise indicated.

The finish shall have a rating of six or greater according to ASTM D1654, Section 8.0 Procedure A – Evaluation of Rust Creepage for Scribed Samples after exposure to 1000 hours of testing according to ASTM B117 for painted or finished surfaces under environmental exposure.

The luminaire finish shall have less than or equal to 30% reduction of gloss according to ASTM D523 after exposure of 500 hours to ASTM G154 Cycle 6 QUV® accelerated weathering testing.

The luminaire shall slip-fit on a 2 to 2 3/8 in. (50 to 60 mm) O.D. pipe arm and shall have a barrier to limit the amount of insertion. The mounting shall be fully coordinated with the luminaire mounting method indicated in plans.

All external surfaces shall be cleaned in accordance with the manufacturer's recommendations and be constructed in such a way as to discourage the accumulation of water, ice, and debris.

The effective projected area of the luminaire shall not exceed 2.1 sq. ft.

The total weight including accessories, shall not exceed 80 lbs (36.3 kg). If the weight of the luminaire is less than 20 lb (9.07 kg), weight shall be added to the mounting arm or a supplemental vibration damper installed as approved by the Engineer.

A passive cooling method with no moving, rotating parts, or liquids shall be employed for heat management.

The luminaire shall include a fully prewired, 7-pin twist lock ANSI C136.41-compliant receptacle. Unused pins shall be connected as directed by the Manufacturer and as approved by the Engineer. A shorting cap shall be provided with the luminaire that is compliant with ANSI C136.10.

Vibration Testing. All luminaires shall be subjected to and pass vibration testing requirements at "3G" minimum zero to peak acceleration in accordance with ANSI C136.31 requirements using the same luminaire. To be accepted, the luminaire housing, hardware, and each individual component shall pass this test with no noticeable damage and the luminaire must remain fully operational after testing.

Labels. An internal label shall be provided indicating the luminaire is suitable for wet locations and indicating the luminaire is an NRTL listed product to UL1598 and UL8750. The internal label shall also comply with the requirements of ANSI C136.22.

An external label consisting of two black characters on a white background with the dimensions of the label and the characters as specified in ANSI C136.15 for HPS luminaires. The first character shall be the alphabetical character representing the initial lumen output as specified in Table 1 of Article 1067.06(c). The second character shall be the numerical character representing the transverse light distribution type as specified in IES RP-8 (i.e. Types 1, 2, 3, 4, or 5).

Hardware. All hardware shall be stainless steel or of other corrosion resistant material approved by the Engineer.

Luminaires shall be designed to be easily serviced, having fasteners such as quarter-turn clips of the heavy spring-loaded type with large, deep straight slot heads, complete with a receptacle and shall be according to military specification MIL-f-5591.

All hardware shall be captive and not susceptible to falling from the luminaire during maintenance operations. This shall include lens/lens frame fasteners as well hardware holding the removable driver and electronic components in place.

Provisions for any future house-side external or internal shielding should be indicated along with means of attachment.

Circuiting shall be designed to minimize the impact of individual LED failures on the operation of the other LED's.

Wiring. Wiring within the electrical enclosure shall be rated at 600v, 105°C or higher.

#### Driver.

The driver shall be integral to the luminaire shall be capable of receiving an indefinite open and short circuit output conditions without damage.

The driver shall incorporate the use of thermal foldback circuitry to reduce output current under abnormal driver case temperature conditions and shall be rated for a lifetime of 100,000 hours at an ambient temperature exposure of 77 °F (25 °C) to the luminaire. If the driver has a thermal shut down feature, it shall not turn off the LEDs when operated at 104 °F (40 °C) or less.

The driver shall have an input voltage range of 120 to 277 volts ( $\pm 10\%$ ) or 347 to 480 volts ( $\pm 10\%$ ) according to the contract documents. When the driver is operating within the rated input voltage range and in an un-dimmed state, the power factor measurement shall be not less than 0.9 and the THD measurement shall be no greater than 20%.

The driver shall meet the requirements of the FCC Rules and Regulations, Title 47, Part 15 for Class A devices with regard to electromagnetic compatibility. This shall be confirmed through the testing methods in accordance with ANSI C63.4 for electromagnetic interference.

The driver shall be dimmable using the protocol listed in the Luminaire Performance Table shown in the contract.

Surge Protection. The luminaire shall comply the requirements of ANSI C136.2 for electrical transient immunity at the "Extreme" level (20KV/10KA) and shall be equipped with a surge protective device (SPD) that is UL1449 compliant with indicator light. An SPD failure shall open the circuit to protect the driver.

#### LED Optical Assembly

The optical assembly shall have an IP65 or higher rating in accordance with ANSI C136.25. The circuiting of the LED array shall be designed to minimize the effect of individual LED failures on the operation of other LEDs. All optical components shall be made of glass or a UV stabilized, non-yellowing material.

The optical assembly shall utilize high brightness, long life, minimum 70 CRI, 4,000K color temperature (+/-300K) LEDs binned in accordance with ANSI C78.377. Lenses shall be UV-stabilized acrylic or glass.

Lumen depreciation at 50,000 hours of operation shall not exceed 15% of initial lumen output at the specified LED drive current and an ambient temperature of 25° C.



The luminaire may or may not have a glass lens over the LED modules. If a glass lens is used, it must be a flat lens. Material other than glass will not be acceptable. If a glass lens is not used, the LED modules may not protrude lower than the luminaire housing.

The optical assembly shall be capable of being rotated 360 degrees around its vertical axis. The luminaire shall be equipped with identifying markings to indicate the mounted orientation. Luminaire installation shall include engraved banding of the mounting arms to designate proper orientation.

The assembly shall have individual serial numbers or other means for manufacturer tracking.

#### Photometric Performance.

Luminaires shall be tested according to IESNA LM-79. This testing shall be performed by a test laboratory holding accreditation from the National Institute of Standards and Technology (NIST) National Voluntary Laboratory Accreditation Program (NVLAP) for the IESNA LM-79 test procedure.

Data reports as a minimum shall yield an isofootcandle chart, with max candela point and half candela trace indicated, maximum plane and maximum cone plots of candela, a candlepower table (house and street side), a coefficient of utilization chart, a luminous flux distribution table, spectral distribution plots, chromaticity plots, and other standard report outputs of the above-mentioned tests.

The luminaire shall have a BUG rating of Back Light B3 or less, Up Light rating of U0, and a Glare rating of G3 or less unless otherwise indicated in the luminaire performance table.

#### Photometric Calculations.

Calculations. Submitted report shall include a luminaire classification system graph with both the recorded lumen value and percent lumens by zone along with the BUG rating according to IESNA TM-15.

Complete point-by-point luminance and veiling luminance calculations as well as listings of all indicated averages and ratios as applicable shall be provided in accordance with IESNA RP-8 recommendations. Lighting calculations shall be performed using AGI32 software with all luminance calculations performed to one decimal place (i.e. x.x cd/m<sup>2</sup>). Uniformity ratios shall also be calculated to one decimal place (i.e. x.x:1). Calculation results shall demonstrate that the submitted luminaire meets the lighting metrics specified in the project Luminaire Performance Table(s). Values shall be rounded to the number of significant digits indicated in the luminaire performance table(s).

All photometry must be photopic. Scotopic or mesopic factors will not be allowed. The AGI32 file shall be submitted at the request of the Engineer.

**IDOT DISTRICT 1 LUMINAIRE PERFORMANCE TABLE  
 ROADWAY LIGHTING**

**GIVEN CONDITIONS**

Roadway Data	Pavement Width	24	Ft
	Number of Lanes Left of Median	2	
	Number of Lanes Right of Median	N/A	
	Lane Width	12	Ft
	Median Width	N/A	Ft
	IES Surface Classification	R3	
	Q-Zero Value	0.07	
Mounting Data	Mounting Height	75	Ft
	Mast Arm Length	15	Ft
	Tower Set-Back from Edge of Pavement	100	Ft
Luminaire Data	Source	LED	
	Color Temperature	4000	°K
	Lumens	92,000	Min
	Pay Item Lumen Designation	K	
	BUG Rating	B5-U0-G5	
	IES Vertical Distribution	Medium	
	IES Control of Distribution	Cutoff	
	IES Lateral Distribution	Type 3/4	
	Total Light Loss Factor	0.70	
Tower Layout Data	Spacing	150	Ft
	Configuration	Single Sided	
	Number of Luminaires per Tower	1	

**NOTE:** Variations from the above specified I.E.S. distribution pattern may be requested, and acceptance of variations will be subject to review by the Engineer based on how well the performance requirements are met.

**PERFORMANCE REQUIREMENTS**

**NOTE:** These performance requirements shall be the minimum acceptable standards of photometric performance for the luminaire, based on the given conditions listed above.

Roadway Luminance	Average Luminance, $L_{AVE}$ (Max)	1.2	Cd/m <sup>2</sup>
	Average Luminance, $L_{AVE}$ (Min)	0.8	Cd/m <sup>2</sup>
	Uniformity Ratio, $L_{AVE}/L_{MIN}$	3.0	Max
	Uniformity Ratio, $L_{MAX}/L_{MIN}$	5.0	Max
	Veiling Luminance Ratio, $L_V/L_{AVE}$	0.3	Max

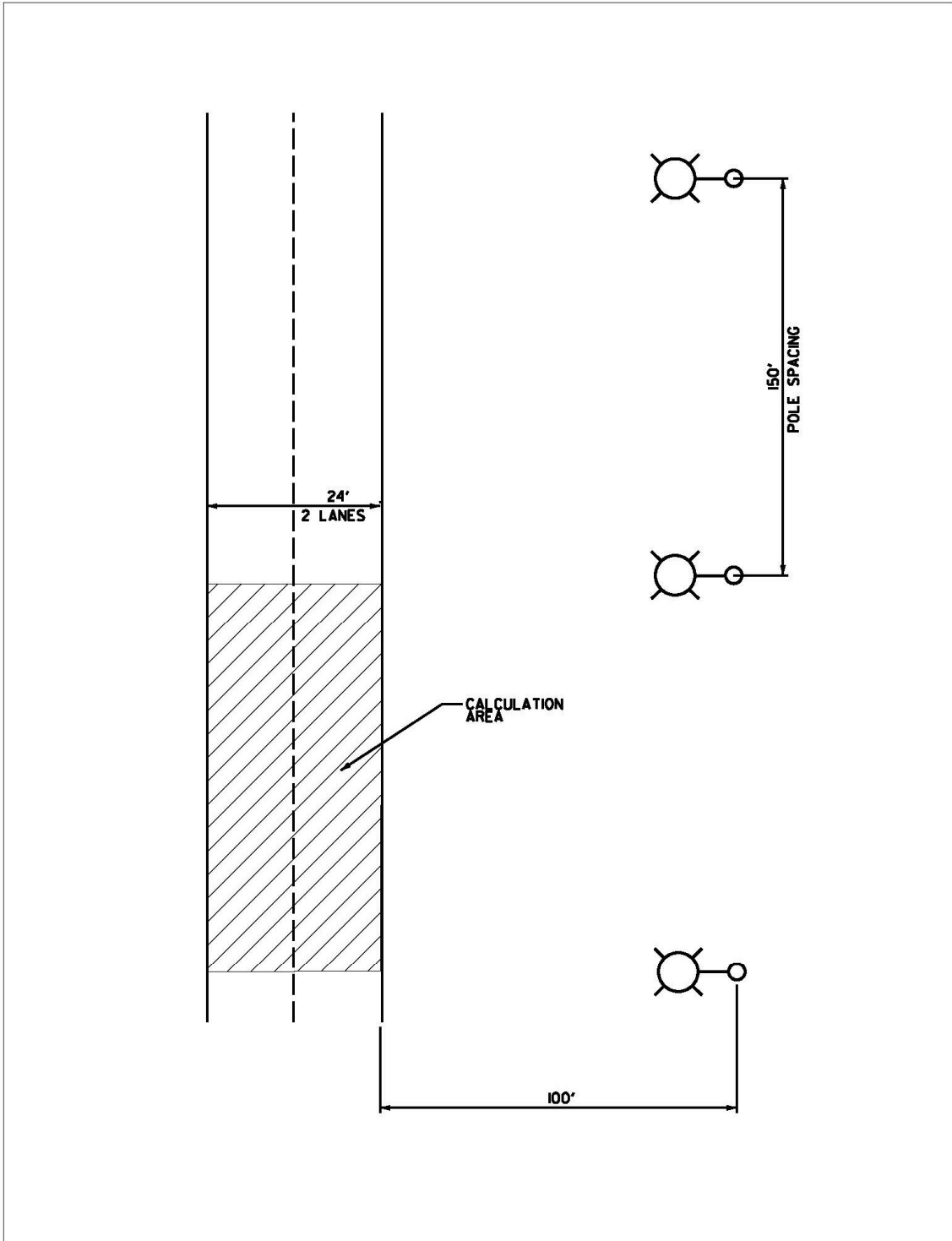

Independent Testing

When a contract has 50 or more luminaires of the same type (distribution type and lumen output/wattage), that luminaire type shall be independently tested, unless otherwise noted. The quantity of luminaires to be tested shall be as specified in the following table.

<b>Contract Quantity</b>	<b>Luminaires to be Tested</b>
1-49	0 (unless otherwise noted)
50-100	2
101-150	3
151-200	4
201-250	5
251-300	6
301-350	7

Testing is not required for temporary lighting luminaires.

The Contractor shall coordinate the testing with the contract schedule considering submittal, manufacturing, testing, and installation lead-times and deadlines.

The Electrical Engineer shall select from all the project luminaires at the Contractor's or distributor's storage facility, within District 1, the luminaires for testing. In all cases, the selection of luminaires shall be a random selection from the entire completed lot of luminaires required for the contract. Selections from partial lots will not be allowed. An additional luminaire shall also be selected for physical inspection by the Engineer at the District Headquarters. This luminaire will be available for the Contractor to pick up at a later date to be installed under this contract. This luminaire is in addition to the luminaire required as a part of the submittal process specified elsewhere.

Alternative selection process. With the Engineer's prior approval, the Contractor shall provide a list of luminaire serial numbers for all the luminaires. The Engineer shall make a random selection of the required number of luminaires for testing from the serial numbers. That luminaire must then be photographed clearly showing the serial number prior to shipment to the selected and approved testing laboratory. The testing laboratory shall include a photograph of the luminaire along with the test results directly to the Engineer.

Luminaires shall be tested at a National Voluntary Laboratory Accreditation Program (NVLAP) accredited laboratory approved for each of the required tests. The testing facility shall not be associated in any way, subsidiary or otherwise, with the luminaire manufacturer. All costs associated with luminaire testing shall be included in the bid price of the luminaire.

The selection of the proposed independent laboratory shall be presented with the information submitted for review and approval.

The testing performed shall include photometric and electrical testing.

**All tests shall be conducted at the luminaire system operating voltage of 240 volts unless specified differently in the contract plans.**

Photometric testing shall be according to IES recommendations, performed with a goniophotometer and as a minimum, shall yield an isofootcandle chart, with max candela point and half candela trace indicated, an isocandela diagram, maximum planned and maximum cone plots of candela, a candlepower table (House and street side), a coefficient of utilization chart, a luminous flux distribution table, BUG rating report, and complete calculations based on specified requirements and test results.

Electrical testing shall conform to NEMA and ANSI standards and, as a minimum shall include a complete check of wiring connections and a table of characteristics showing input amperes, watts, power factor, total harmonic distortion and LED drive current.

The summary report and the test results including IES photometric files shall be sent directly to the Resident Engineer, the Electrical Engineer, and the Contractor via email or other mutually agreeable means.

Photometric performance shall meet or exceed that of the specified values. If the luminaire does not meet the specified photometric values, the luminaire has failed regardless of whether the test results meet the submitted factory data.

Should any of the tested luminaires of a given type, and distribution fail to satisfy the specifications and perform according to approved submittal information, the luminaire type of that distribution type and wattage shall be unacceptable and be replaced by alternate equipment meeting the specifications with the submittal and testing process repeated in their entirety; or corrections made to achieve required performance.

In the case of corrections, the Contractor shall advise the Engineer of the proposed corrections and shall request a repeat of the specified testing and, if the corrections are deemed reasonable by the Engineer, the testing process shall be repeated in its entirety.

The number of luminaires to be tested shall be the same quantity as originally tested as required in the above table.

Retesting, should it become necessary, shall not be grounds for additional compensation or extension of time

Submittal information shall include a statement of intent to provide the testing as well as a request for approval of the chosen laboratory.

### Installation.

Each luminaire shall be installed according to the luminaire manufacturer's recommendations.

Luminaires shall be leveled/adjusted before being energized. When mounted on a tenon, care shall be exercised to assure maximum insertion of the mounting tenon. Each luminaire shall be checked to assure compatibility with the project power system. When the night-time check of the lighting system by the Engineer indicates that any luminaires are mis-aligned, the mis-aligned luminaires shall be corrected at no additional cost.

No luminaire shall be installed prior to approval. Where independent testing is required, full approval will not be given until complete test results, demonstrating compliance with the specifications, have been reviewed and accepted by the Engineer.

Each luminaire and optical assembly shall be free of all dirt, smudges, etc. Should the optical assembly require cleaning, a luminaire manufacturer approved cleaning procedure shall be used.

Luminaires having asymmetrical photometric distributions shall be carefully oriented with respect to the roadway as indicated on the plans and as directed by the Engineer. The Contractor shall confirm all luminaire orientations with the Engineer prior to installation.

For horizontal mounts having rotating optical assemblies, after the orientation of each mast arm tenon is inspected and approved by the Engineer, the position shall be permanently marked in a manner acceptable to the Engineer. The luminaire shall then be leveled to the plane of the luminaire ring.

When the luminaire position and orientation has been confirmed and approved by the Engineer, the luminaire shall be anchored with a minimum size 1/4-20NC stainless steel bolt installed through tapped holes in the tenon and mounting bracket of the luminaire. The bolt shall not penetrate into the tenon more than 1/4 in. (6 mm). Counterweights on un-used tenons shall be mounted in a similar manner. Pre-installed wire on the tower ring shall have the ends of each wire capped at the tenon with butt type crimp-connectors for un-used tenons. The wires shall then be re-inserted into the tenon end and the tenon end shall be capped.

### Warranty.

The entire luminaire and all component parts shall be covered by a 10-year warranty. Failure is when one or more of the following occur:

- 1) Negligible light output from more than 10 percent of the discrete LEDs.
- 2) Significant moisture that deteriorates performance of the luminaire.
- 3) Driver that continues to operate at a reduced output due to overheating.

**The warranty period shall begin on the date of luminaire delivery.** The Contractor shall verify that the Resident Engineer has noted the delivery date in the daily diary. Copy of the shipment documentation shall be submitted.

The replacement luminaire shall be of the same manufacturer, model, and photometric distribution as the original.

Method of Measurement.

The rated initial minimum luminous flux (lumen output) of the light source, as installed in the luminaire, shall be according to the following table for each specified output designation.

<b>Designation Type</b>	<b>Minimum Initial Luminous Flux</b>
H	25,200
I	47,250
J	63,300
K	80,000+

Where delivered lumens is defined as the minimum initial delivered lumens at the specified color temperature. Luminaires with an initial luminous flux less than the values listed in the above table will not be acceptable even if they meet the requirements given in the Luminaire Performance table shown in the contract.

Basis of Payment.

This work will be paid for at the contract unit price per each for **LUMINAIRE, LED, HIGHMAST, or TEMPORARY LUMINAIRE, LED, HIGHMAST**, of the output designation specified.

**BREAKAWAY DEVICE**

Effective: January 1, 2023

Revise the first sentence of Article 1070.04(b)(2) to read:

“The device shall be approximately 9 in. (230 mm) high and shall have a large fiberglass or polyethylene access door of a color to match the base finish which shall be held in place with a button-type tamper resistant stainless-steel screw or other means approved by the Engineer.”

## **LUMINAIRE SAFETY CABLE ASSEMBLY**

Effective: January 1, 2012

**Description:** This item shall consist of providing a luminaire safety cable assembly as specified herein and as indicated in the plans.

**Materials.** Materials shall be according to the following:

**Wire Rope.** Cables (wire rope) shall be manufactured from Type 304 or Type 316 stainless steel having a maximum carbon content of 0.08 % and shall be a stranded assembly. Cables shall be 3.18 mm (0.125") diameter, 7x19 Class strand core and shall have no strand joints or strand splices.

Cables shall be manufactured and listed for compliance with Federal Specification RR-W-410 and Mil-DTL-83420.

Cable terminals shall be stainless steel compatible with the cable and as recommended by the cable manufacturer. Terminations and clips shall be the same stainless-steel grade as the wire rope they are connected to.

**U-Bolts.** U-Bolts and associated nuts, lock washers, and mounting plates shall be manufactured from Type 304 or Type 316 stainless steel.

## **CONSTRUCTION REQUIREMENTS**

**General.** The safety cable assembly shall be installed as indicated in the plan details. One end of the cable assembly shall have a loop fabricated from a stainless steel compression sleeve. The other end of the cable assembly shall be connected with stainless steel wire rope clips as indicated. Slack shall be kept to a minimum to prevent the luminaire from creeping off the end of the mast arm. Unless otherwise indicated in the plans, the luminaire safety cable shall only be used in conjunction with luminaires which are directly above the traveled pavement.

**Basis of Payment:** This work shall be paid for at the contract price each for **LUMINAIRE SAFETY CABLE ASSEMBLY**, which shall be payment for the work as described herein and as indicated in the plans.



## **MAINTENANCE OF LIGHTING SYSTEMS**

Effective: March 1, 2017

Replace Article 801.11 and 801.12 of the Standard Specifications with the following:

Effective the date the Contractor's activities (electrical or otherwise) at the job site begin, the Contractor shall be responsible for the proper operation and maintenance of all existing and proposed lighting systems which are part of, or which may be affected by the work until final acceptance or as otherwise determined by the Engineer.

Before performing any excavation, removal, or installation work (electrical or otherwise) at the site, the Contractor shall initiate a request for a maintenance transfer and preconstruction inspection, as specified elsewhere herein, to be held in the presence of the Engineer and a representative of the party or parties responsible for maintenance of any lighting systems which may be affected by the work. During the maintenance preconstruction inspection, the party responsible for existing maintenance shall perform testing of the existing system in accordance with Article 801.13a. The Contractor shall request a date for the preconstruction inspection no less than fourteen (14) days prior to the desired date of the inspection.

The Engineer will document all test results and note deficiencies. All substandard equipment will be repaired or replaced by the existing maintenance contractor, or the Engineer can direct the Contractor to make the necessary repairs under Section 109.04.

Existing lighting systems, when depicted on the plans, are intended only to indicate the general equipment installation of the systems involved and shall not be construed as an exact representation of the field conditions. It remains the Contractor's responsibility to visit the site to confirm and ascertain the exact condition of the electrical equipment and systems to be maintained. Contract documents shall indicate the circuit limits.

### **Maintenance of Existing Lighting Systems**

**Existing lighting systems.** Existing lighting systems shall be defined as any lighting system or part of a lighting system in service at the time of contract Letting. The contract drawings indicate the general extent of any existing lighting, but whether indicated or not, it remains the Contractor's responsibility to ascertain the extent of effort required for compliance with these specifications and failure to do so will not be justification for extra payment or reduced responsibilities.

### **Extent of Maintenance.**

**Partial Maintenance.** Unless otherwise indicated, if the number of circuits affected by the contract is equal to or less than 40% of the total number of circuits in a given controller and the controller is not part of the contract work, the Contractor needs only to maintain the affected circuits within the project limits. The project limits are defined as those limits indicated in the contract plans. Equipment outside of the project limits, on the affected circuits shall be maintained and paid for under Article 109.04. The affected circuits shall be isolated by means of in-line waterproof fuse holders as specified elsewhere and as approved by the Engineer. The unaffected circuits and the controller will remain under the maintenance of the State.

**Full Maintenance.** If the number of circuits affected by the contract is greater than 40% of the total number of circuits in a given controller, or if the controller is modified in any way under the contract work, the Contractor shall maintain the entire controller and all associated circuits within the project limits. Equipment outside of the project limits shall be maintained and paid for under Article 109.04.

If the existing equipment is damaged by normal vehicular traffic, not contractor operations, is beyond repair and cannot be re-set, the contractor shall replace the equipment in kind with payment made for such equipment under Article 109.04. If the equipment damaged by any construction operations, not normal vehicular traffic, is beyond repair and cannot be re-set, the contractor shall replace the equipment in kind and the cost of the equipment shall be included in the cost of this pay item and shall not be paid for separately.

### **Maintenance of Proposed Lighting Systems**

**Proposed Lighting Systems.** Proposed lighting systems shall be defined as any lighting system or part of a lighting system, temporary or permanent, which is to be constructed under this contract regardless of the project limits indicated in the plans.

The Contractor shall be fully responsible for maintenance of all items installed under this contract. Maintenance shall include, but not be limited to, any equipment failures or malfunctions as well as equipment damage either by the motoring public, Contractor operations, vandalism, or other means. The potential cost of replacing or repairing any malfunctioning, damaged, or vandalized equipment shall be included in the bid price of this item and will not be paid for separately.

**Lighting System Maintenance Operations**

The Contractor's responsibility shall include all applicable responsibilities of the Electrical Maintenance Contract, State of Illinois, Department of Transportation, Division of Highways, District One. These responsibilities shall include the maintenance of lighting units (including sign lighting), cable runs and lighting controls. In the case of a pole knockdown or sign light damage, the Contractor shall promptly clear the lighting unit and circuit discontinuity and restore the system to service. The equipment shall then be re-set by the contractor within the time limits specified herein.

If the existing equipment is damaged by normal vehicular traffic, not contractor operations, is beyond repair and cannot be re-set, the contractor shall replace the equipment in kind with payment made for such equipment under Article 109.04. If the equipment damaged by any construction operations, not normal vehicular traffic, is beyond repair and cannot be re-set, the contractor shall replace the equipment in kind and the cost of the equipment shall be included in the cost of this pay item and shall not be paid for separately.

Responsibilities shall also include weekly night-time patrol of the lighting system, with patrol reports filed immediately with the Engineer and with deficiencies corrected within 24 hours of the patrol. Patrol reports shall be presented on standard forms as designated by the Engineer. Uncorrected deficiencies may be designated by the Engineer as necessitating emergency repairs as described elsewhere herein.

The following chart lists the maximum response, service restoration, and permanent repair time the Contractor will be allowed to perform corrective action on specific lighting system equipment.

<b>INCIDENT OR PROBLEM</b>	<b>SERVICE RESPONSE TIME</b>	<b>SERVICE RESTORATION TIME</b>	<b>PERMANENT REPAIR TIME</b>
Control cabinet out	1 hour	4 hours	7 Calendar days
Hanging mast arm	1 hour to clear	na	7 Calendar days
Radio problem	1 hour	4 hours	7 Calendar days
Motorist caused damage or leaning light pole 10 degrees or more	1 hour to clear	4 hours	7 Calendar days
Circuit out – Needs to reset breaker	1 hour	4 hours	na
Circuit out – Cable trouble	1 hour	24 hours	21 Calendar days
Outage of 3 or more successive lights	1 hour	4 hours	na
Outage of 75% of lights on one tower	1 hour	4 hours	na
Outage of light nearest RR crossing approach, Islands and gores	1 hour	4 hours	na
Outage (single or multiple) found on night outage survey or reported to EMC	na	na	7 Calendar days
Navigation light outage	na	na	24 hours

- **Service Response Time** -- amount of time from the initial notification to the Contractor until a patrolman physically arrives at the location.
- **Service Restoration Time** – amount of time from the initial notification to the Contractor until the time the system is fully operational again (In cases of motorist caused damage the undamaged portions of the system are operational.)
- **Permanent Repair Time** – amount of time from initial notification to the Contractor until the time permanent repairs are made if the Contractor was required to make temporary repairs to meet the service restoration requirement.

Failure to provide this service will result in liquidated damages of \$500 per day per occurrence. In addition, the Department reserves the right to assign any work not completed within this timeframe to the Electrical Maintenance Contractor. All costs associated to repair this uncompleted work shall be the responsibility of the Contractor. Failure to pay these costs to the Electrical Maintenance Contractor within one month after the incident will result in additional liquidated damages of \$500 per month per occurrence. Unpaid bills will be deducted from any monies owed to the Contractor. Repeated failures and/or a gross failure of maintenance shall result in the State's Electrical Maintenance Contractor being directed to correct all deficiencies and the resulting costs deducted from any monies owed the contractor.

Damage caused by the Contractor's operations shall be repaired at no additional cost to the Contract.

### **Operation of Lighting**

The lighting shall be operational every night, dusk to dawn. Duplicate lighting systems (such as temporary lighting and proposed new lighting) shall not be operated simultaneously. Lighting systems shall not be kept in operation during long daytime periods.

### **Method of Measurement**

The contractor shall demonstrate to the satisfaction of the Engineer that the lighting system is fully operational prior to submitting a pay request. Failure to do so will be grounds for denying the pay request. Months in which the lighting systems are not maintained and not operational will not be paid. Payment shall not be made retroactively for months in which lighting systems were not operational.

**Basis of Payment.** Maintenance of lighting systems shall be paid for at the contract unit price per calendar month for **MAINTENANCE OF LIGHTING SYSTEM.**

#### **TEMPORARY WOOD POLE, 50 FT., CLASS 4**

##### **Description.**

This item shall consist of furnishing and installing temporary wood pole, hardware and accessories required for temporary installation.

##### **Materials.**

The materials shall be in accordance with article 1069.04 of the Standard Specifications.

#### **CONSTRUCTION REQUIREMENTS**

##### **Installation.**

The wood pole shall be installed in accordance with article 830.03 (c) of the Standard Specifications. The wood pole shall be installed such that minimum required buried depth shall be maintained for existing and proposed grade.

##### **Basis of Payment.**

This work will be paid for at the contract unit price per each for TEMPORARY WOOD POLE, 50 FT., CLASS 4 which shall be payment in full for the work specified herein.

#### **REMOVE TEMPORARY WOOD POLE**

##### **Description.**

This item shall consist of the disconnection and removal of the temporary wood pole and associated aerial cable.

##### **General**

Removal of the temporary wood pole shall be performed in accordance with the applicable sections of Article 841.02 of the Standard Specifications.

##### **Basis of Payment.**

This work will be paid for at the contract unit price per each for REMOVE TEMPORARY WOOD POLE which shall be payment in full for all labor, equipment and material necessary to perform the work specified herein.

**GROUNDING OF ITS SUBSYSTEMS (TSC T 420#8)**

Effective: March 12, 2009

The grounding of ITS subsystems shall meet the requirements of Section 806 of the Standard Specifications. In addition, amend Article 806.03 of the Standard Specifications to include:

General. All ITS subsystems (ramp metering system, dynamic message sign system, system detector stations, etc.), associated equipment, and appurtenances shall be properly grounded in strict conformance with the NEC and as shown on the Plans.

Testing shall be according to Section 801. 13(a)(5) of the Standard Specifications:

The grounded conductor (neutral conductor) shall be white color-coded. This conductor shall be bonded to the equipment-grounding conductor only at the Electric Service installation. All power cables shall include one neutral conductor of the same size as the phase (hot) conductors.

The equipment-grounding conductor shall be green color-coded. The following is in addition to Section 801.04 of the Standard Specifications.

Equipment grounding conductors shall be XLP insulated No. 6, unless otherwise noted on the Plans, and bonded to the grounded conductor (neutral conductor) only at the Electric Service Installation. The equipment-grounding conductor is paid for separately and shall be continuous. The Earth shall not be used as the equipment-grounding conductor.

Equipment grounding connectors shall be bonded, using a listed grounding conductor, to all ramp meters, DMS, and detector cabinets, handholes, and other metallic enclosures throughout the ITS subsystems, except where noted herein. A listed electrical joint compound shall be applied to all conductor terminations, connector threads, and contact points.

All metallic and non-metallic raceways containing ITS circuit runs shall have a continuous equipment grounding conductor, except raceways containing only detector loop lead-in circuits, circuits under 50 volts and/or fiber optic cable will not be required to include an equipment grounding conductor.

The grounding electrode conductor shall be similar to the equipment grounding conductor in color-coding (green) and size. The grounding electrode conductor is used to connect the ground rod to the equipment grounding conductor and is bonded to ground rods via exothermic welding, listed pressure connectors, listed clamps or other approved listed means.

Basis of Payment. Payment shall be included in the various items associated with ITS.

## ATMS INTEGRATION

**Description.** This item includes integrating all detector loop installations shown on the plans into the IDOT Advanced Traffic Management System (ATMS). Data from the detector loops will be collected and integrated via the existing iNET interface to the ATMS. This item includes all software, programming, miscellaneous devices, cabinets, racks, and cables necessary to provide the successful integration of the existing stations in the project to the existing expressway traffic monitoring system. This item shall provide data to the Gateway Traveler Information System (see Gateway Integration special provision).

Work as necessary will be performed at the:

Illinois Department of Transportation  
Bureau of Traffic Operations/Electrical Field Office  
445 W. Harrison Street  
Oak Park, Illinois 60304

**Integration.** The Contractor shall subcontract with the development and maintenance contractor for the ATMS to perform all ATMS software and hardware modifications. Contact information is:

Parsons  
Preston Judkins  
650 E Algonquin Rd, Suite 104  
Schaumburg, IL 60173  
Phone: (847) 485-1062  
Email: preston.judkins@parsons.com

The ATMS system shall be upgraded and expanded to add all detector loops shown on the plans. The integration must be made to make this expansion a seamless transition, and function in an identical manner as the existing expressway surveillance. Work under this item includes but is not limited to the following:

- Integrate data from the additional detector loops through the existing iNET interface at the existing rate of once every 20 seconds.
- Create new Vehicle Detection Station (VDS) display, data table, description and control panel display, and travel time tables.
- Modify the existing graphic user interface, report generators, data bases, broadcast feeds (both subscriber and internal), and data tables for the dynamic message sign control.

- Display on the Traffic Systems Center ATMS maps, and all user interfaces the new detector loop data (as applicable) including volume, occupancy, speed, vehicle classification (length), and operational status.
- Display the operational status of detector loops on the Traffic Systems Center ATMS maps and all user interfaces.
- Create new segments and groupings used to display travel time and congestion data to the Dynamic Message Signs.
- Provide the Gateway XML data feeds for presentation of the additional data to the Gateway web page and user interfaces (see Gateway Integration special provision).
- Update the Lake Michigan Interstate Gateway Alliance (LMIGA) data feeds for presentation of the additional data to the web page and user interfaces.
- Develop an integration acceptance test plan and conduct said test to verify that all detector loops have been properly integrated according to the requirements. This acceptance plan shall conclude with a 30-day burn-in period. During the burn-in period, the subcontractor shall identify and resolve any problems identified with the integration.
- Coordinate with the Roadside Detector manufacturer, ATMS Integration Programmer, and Gateway Integration Programmer.

**Method of Measurement.** The ATMS Integration shall be measured as lump sum.

**Basis of Payment.** This item shall be paid for at the contract lump sum price for ATMS INTEGRATION, which price shall be payment in full for the work described for a complete seamless integration of the new detector loops into the existing IDOT ATMS System. Acceptance shall be granted after integration and after passing an acceptance test proposed by the Subcontractor, and agreed upon by the Engineer.



## **MAINTAINING ITS DURING CONSTRUCTION**

**Description.** Intelligent Transportation Systems (ITS) references IDOT traffic surveillance infrastructure. These elements include, but are not limited to, the following: induction loops, ramp meters, closed circuit television cameras, surveillance cabinets, Radar Vehicle Sensing Devices (RVSDs), Wireless Vehicle Detection Systems, electric services, copper and fiber optic communication cables, power cables, cabinets, and communication equipment.

**General Requirements.** Effective the date the Contractor's activities (ITS or otherwise) begin at the job site, the Contractor shall be responsible for the proper operation and maintenance of ITS elements that are part of, or that may be affected by the work until final acceptance by the Engineer or as otherwise determined by the Engineer.

Before performing any excavation, removal, or installation work (ITS or otherwise) at the site, the Contractor shall initiate a request for a maintenance transfer and preconstruction inspection to be held in the presence of the Engineer and a representative of the party or parties responsible for maintenance of any ITS systems that may be affected by the work. This includes co-ordination with the adjacent project, Contract 62R28 that will have an effect on the ITS infrastructure. The request for the maintenance preconstruction inspection shall be made no less than seven (7) calendar days prior to the desired inspection date.

It will be the Contractor's responsibility to document any existing ITS elements. It is the Contractor's responsibility to visit the site and ascertain the exact condition and location of the ITS components and systems to be maintained and installed.

Existing ITS components shall be defined as any ITS component or device in service at the time of the commencement of construction activities. The contract drawings indicate the general extent of any existing ITS elements, but whether indicated or not, it remains the Contractor's responsibility to ascertain the extent of effort required for compliance with these specifications, and failure to do so will not be justification for extra payment or reduced responsibilities.

Maintaining ITS During Construction - It is the Contractor's responsibility to maintain vehicle detection at the I-80 & I-55 interchange, which includes speed and volume data, in all lanes on all roadway segments and ramps that will be open to traffic. Where the existing detection cannot be maintained, the Contractor shall provide a temporary detection system, approved by IDOT, at no additional cost to the contract. The Contractor's responsibility shall also include maintenance of the existing Closed Circuit Television (CCTV) cameras at the I-80 & I-55 interchange, including re-establishing power to both locations via a new electric service as shown on the plans. The Contractor's responsibility shall include protection of any ITS/Communication cabinets and protecting in place any cables, conduits and ITS devices in or adjacent to the work zone as shown on the plans to remain in place. This work may also include the abandonment of the existing device and communication pathway and the installation of a temporary device or communication pathway. It is the Contractor's responsibility to maintain closed circuit television cameras including associated fiber optic communications and power.

The Contractor is responsible for the disconnection, rerouting, and reconnection of all fiber and copper communication cables and power cables currently located in existing conduits if indicated in the plans. The disconnection and reconnection must be made at an existing splice point or communication cabinet where a connection is made, or as otherwise indicated in the plans. The existing communication and infrastructure must be properly maintained for the duration of construction activities and the Contractor must coordinate the disconnection and reconnection activities with the Engineer. Fiber outages may typically be allowed Sunday through Thursday night (9 PM – 5 AM) or Friday/Saturday night (9 PM – 9 AM).

All work required to maintain or provide temporary ITS infrastructure as depicted in the plans or otherwise necessary and as provided for in this special provision shall be paid for under the Maintaining ITS During Construction pay item. All work required to relocate ITS infrastructure as depicted in the plans shall be paid for separately.

Once construction activities are complete, all temporary equipment installed will become the property of the Department and shall remain in place, except where a proposed location has been identified in the plans. All final locations and installations of ITS devices, communication cabinets, junction boxes, conduit, fiber optic, power cable, wireless equipment and associated infrastructure shall be protected, secured and have the Engineer's approval. Proper documentation of the location of all equipment and communication and power cable pathways shall be in accordance with the GENERAL ELECTRICAL REQUIREMENTS. The proposed plan for this work must be presented to the Engineer for approval prior to the commencement of the work.

**Method of Measurement.** This work will be measured for payment in calendar months or fraction thereof.

**Basis of Payment.** This work will be paid for at the contract unit price per calendar month (CAL MO) for MAINTAINING ITS DURING CONSTRUCTION, which shall include all work as described herein. The contractor shall demonstrate to the satisfaction of the Engineer that the ITS components, devices and infrastructure have been properly installed, protected and maintained and that the appropriate data is being transmitted to the IDOT Traffic Systems Center prior to submitting a pay request. In order for final payment to be released the contractor must demonstrate that the equipment is working as intended following inspection by the Engineer. Failure to do so will be grounds for denying the pay request.

## **ELECTRICAL CABLE IN CONDUIT, 4C/NO. 18 SHIELDED LOOP LEAD-IN**

**Description.** This work shall consist of furnishing materials and labor for installation of shielded loop lead-in cables in conduit as specified herein and indicated by the Engineer, complete with all identification, terminating and testing.

### **Materials.**

#### General

The loop lead-in shall be Canoga 30003 or equal cable. The jacket of high-density polyethylene shall be rated to 600 volts in accordance with UL 83 Section 36. All cables shall be UL listed. Unless otherwise indicated, all cable shall be rated 600 volts. The cable shall be rated 90 degrees C dry and 75 degrees C wet and shall be suitable for installation in wet and dry locations, exposed to the weather, and shall be resistant to oils and chemicals.

The UL listing mark, cable voltage, insulation type and ratings, as well as the cable size shall all be clearly printed on the cable in a color contrasting with the insulation color.

#### Conductors

Conductors shall be #18 awg 7X.0152" un-coated copper. Conductors shall meet the requirements of ASTM Designation B-8 as applicable.

Unless otherwise indicated, all conductors shall be stranded and twisted 4 turns per foot.

The cable shall be an assembly of pairs of left hand lay twisted insulated conductors, with a core filled with a petroleum base flooding compound, overlapped conductive tape shield and a black high density polyethylene jacket overall. The cable shall meet the requirements of IEEE Standard 383.

#### Insulation

The conductors shall be coded as follows: black-red-white-green.

Cable insulation shall incorporate polyvinyl chloride (PVC) with a clear nylon covering overall as specified and the insulation shall meet or exceed the requirements of ICEA S-61-402, NEMA Standard Publication No. WC-5, UL Standard 83, as applicable.

Unless otherwise indicated, cable conductors shall be solid full color coded via insulation color.

#### Quality Control

Submittal information shall include demonstration of compliance with all specified requirements.

All cables shall be delivered to the site in full reels. Cable on the reels shall be protected from damage during shipment and handling by wood lagging or other means acceptable to the Engineer. Reels shall be tagged or otherwise identified to show the UL listing.

**CONSTRUCTION REQUIREMENTS**

Installation

The loop lead-in shall be barrel sleeved, crimped, soldered and protected by heat shrinkable tubing to the loop #14 wire. Lead-ins shall be twisted in such a manner so as to prevent mechanical movement between the individual cables. Lead-ins shall be twisted in such a manner so as to prevent mechanical movement between the individual cables. Lead-ins shall be brought into the cabinet or handhole at the time the induction loop is placed in the pavement. Loops located over 1000 feet from cabinet require four (4) turns of No. 14 wire.

Lead-in cable, Canoga 30003 or equivalent will be installed where the lead-in length from point of interception to the point of termination exceeds 150 feet.

Where lead-in runs are less than 150 feet, the loop wire will be utilized as lead-in to the point of termination w/o splices, being twisted 5 turns per foot. The loop wire will be paid for as "lead-in" from last point of sawcut in pavement at dive hole to point of termination.

Loop lead-ins placed in handholes shall be coiled, taped, and hung from the side of the handhole to protect against water damage. Any other method of installation will require prior written approval of the Engineer. Each loop lead-in shall be color coded and tagged in each handhole through which it passes. The loop lead-in shall be color coded and tagged at the core hole, in each junction box it passes through and at the termination point in the cabinet.

**TRAFFIC SYSTEMS CENTER LOOP SPLICING REQUIREMENT**

<u>MAINLINE LOOPS</u>		<u>METERING LOOPS</u>			
Lane 1	Blue	Lane 4	Violet	Loop 1	Green
Lane 2	Brown	Exit	Black	Loop 2	Yellow
Lane 3	Orange	Entrance	White	Loop 3	Red

When 2 or 3 loops are installed on an exit or entrance ramp the loop color code shall conform to the mainline loop color code and shall be marked as entrance or exit ramp loops.

In addition to color codes each loop shall be identified with a written label attached to the loop wire, or lead-in wire. The tags shall be Panduit #MP250W175-C or equivalent. All wires and cables shall be identified in each handhole or cabinet the cable passes through, or terminates in. The labels shall be attached to the cable by use of two cable ties.

### Testing

After installation, the cable shall be tested as approved by the Engineer. Cable failing to pass the test shall be replaced with new cable at no additional cost.

**Method of Measurement.** The cable shall be measured for payment in feet in place, installed and tested. Measurements shall be made in straight lines between changes in direction and to the centers of Equipment. All vertical cable and permissible cable slack shall be measured for payment. A total of six (6) feet of slack shall be allowed for the end of a run terminating at a panel and four (4) feet will similarly be allowed when terminating at a wall-mounted panel. Additional vertical distance for the height of conduit risers, etc., as applicable, will be measured for payment for equipment so mounted.

**Basis of Payment.** This work shall be paid for at the Contract unit price per linear foot, furnished and installed for ELECTRIC CABLE IN CONDUIT, LEAD-IN, NO. 18 4/C, TWISTED, SHIELDED.

## **INDUCTION LOOP**

**Description.** This item shall consist of furnishing, installing and testing an induction loop, of the dimensions shown on the plans or of the dimension from Table 1, at the locations shown. The induction loop shall be installed in accordance with all applicable portions of Article 886 Standard Specifications for Road and Bridge Construction. All sawcutting, cable installation, joint sealing, lead-ins and testing necessary to complete the installation shall conform with the following requirements.

**Materials.** The cable used for induction loop shall be #14-7 strand XHHW XLP-600V, encased in orange Detecta-duct tubing as manufactured by Kris-Tech Wire Company, Inc., or comparable. Lead-ins shall be as specified in the ELECTRIC CABLE IN CONDUIT, LEAD-IN, NO. 18 4/C, TWISTED, SHIELDED special provision.

Joint sealer shall be a two-part epoxy or polyester resin. The material shall be cured to be flexible, and suitable for sealing induction loops in both HMA and concrete pavements. The cured material shall be highly resistant to oil, gasoline, salts, acids, and alkalis.

## **CONSTRUCTION REQUIREMENTS**

### Installation

Slots in the pavement shall be cut with a concrete sawing machine in accordance with the applicable portions of Section 420 of the Standard Specifications for Road and Bridge Construction. The slot must be clean, dry, and oil-free. Wire shall be inserted in the pavement slot with a blunt tool which will not damage the insulation and wedges made of loop tubing "Detecta-duct" will be installed at eighteen (18) inch intervals to keep new loops from floating. Loops should not be installed at an outside temperature below 50 degrees F (10 degrees C) unless directed by Engineer.

Plastic sleeving shall be used to insulate the wire where loop wire crosses cracks and joints in the pavement. The sleeving shall be properly sealed with electrical tape to prevent joint sealer from entering sleeves. Sleeving shall extend a minimum of 8 inches (20 cm) each side of joint.

All mainline loops shall be round, six (6) feet in diameter, and centered in traffic lanes unless designated otherwise by the Engineer.

The Contractor shall core drill a six-foot diameter round induction loop. The width of the drill portion shall be .500", the depth shall be a maximum of 2.756". A saw cut (home run) .375 in width and the same depth as the drilled portion shall be cut to the core hole. The core hole will be a minimum 2-1/12" diameter and drilled to a depth to meet the installed P-duct. At the point where the 6' diameter loop intercepts the straight cut (home run) the wire leaving the loop will have a minimum of a 1.5" radius entering the straight cut. Interception point of home run slot and round loop shall not be cored.

Induction loops on exit and entrance ramps as well as speed/count stations shall be square or rectangular with edges perpendicular or parallel to traffic flow. Induction loops shall be centered on all ramps and in traffic lanes unless designated otherwise on the plans or by the Engineer. Traffic lanes shall be referred to by number, and loop wire shall be color-coded and labeled accordingly.

A chart, which shows the coding for each installation, shall be included in each cabinet. No core holes shall be allowed at corner of any loop. Sawcuts for all induction loops and lead-ins shall not be greater than 2.75 inches in depth.

All excess joint sealer shall be removed so that the level of the sealer in the sawcut is at the same level as the adjoining pavement.

All induction loops shall contain three (3) turns of No. 14 wire. Each induction loop shall have its own Canoga 30003 or equal home run or lead-in to the cabinet. Induction loops shall not be connected in series with other loops. This wire shall be free from kinks or any insulation abrasions. The loop lead-in shall be barrel sleeved, crimped, soldered and protected by heat shrinkable tubing to the loop #14 wire. Lead-ins shall be placed in such a manner that they take the most direct route to the cabinet.

Lead-in cable, Canoga 30003 or equivalent will only be installed where the lead-in length from point of interception to the point of termination, exceeds 150 feet (45.75m).

Where lead in runs are less than 150 feet (45.75 meters) the loop wire will be utilized as lead-in to the point of termination w/o splices, being twisted 5 turns per foot (304.8mm). The loop wire will be paid for as "lead in" from last point of sawcut in pavement at dive hole to point of termination in cabinet.

Loop lead-ins placed in handholes shall be coiled, taped and hung from hooks on the sides of the handhole to protect against water damage. Any other method of installation will require prior written approval of the Engineer. Each loop lead-in shall be color coded and tagged at the core hole, in each junction box it passes through and at the termination point in the cabinet.

Slots shall be cut so that no bends greater than 50 degrees is used. Diagonal saw cuts (a minimum of twelve (12) inches (304.8mm) in length, shall be used at all corners to conform with this specification. Core hole at corner or cracks shall not be allowed. The Engineer shall be contacted regarding proposed changes in loop locations necessitated by badly deteriorated pavement. The Engineer may relocate such loops.

Copper wire and lead-ins shall not be installed in the curb and gutter section or through the edge of pavement. A hole shall be drilled at least 12” (304.8mm) in from the edge of pavement through which the P-duct, loop wire, and lead-in, shall be installed. Saw cuts through shoulders to core hole shall not be allowed. Loop lead-ins shall not be allowed in saw cuts in shoulders.

<b>RAMP LOOP TABLE (1)</b>	
<b>W (Ft.)(m)</b>	<b>S (Ft.)(m)</b>
12 ft (3.7m)	8 ft. (2.4m)
13 ft (4.0 m)	9 ft (2.8 m)
14 ft (4.3 m)	10 ft (3.1 m)
15 ft (4.6 m)	11 ft (3.4 m)
16 ft (4.9 m)	12 ft (3.7 m)
17 ft (5.2 m)	13ft (4.0 m)
18 ft (5.5 m)	14ft (4.3 m)
19 ft (5.8 m)	15 ft (4.6 m)
20 ft (6.1 m)	16 ft (4.9 m)
21 ft (6.4 m)	17 ft(5.2 m)
22 ft (6.7 m)	18 ft (5.5 m)
23 ft (7.0 m)	19 ft (5.8 m)
24 ft (7.3 m)	20 ft (6.1 m)
25 ft (7.6 m)	21 ft (6.4 m)

\*EXAMPLE: Where lane width (W) is 12’ (3.66m), loop width(s) shall be 8’ (2.44m). Length of loop shall be determined by location.

Should the induction loop and/or core hole for the induction loop and loop lead-in cable be paved over by other construction operations, it shall be the Contractor’s responsibility for locating and finding the induction loop and/or the core hole for the repair of a bad loop or lead-in or for the installation of a new loop or loop lead-in. The locating of the core hole and the induction loop shall be incidental to the cost of the induction loop lead-in installation.

**TRAFFIC SYSTEMS CENTER LOOP SPLICING REQUIREMENT COLOR CODE**

Mainline Loops	Metering Loops	Speed Count
Lane 1 - Blue	Loop 1 – Green – Input Loop	Lane 1 – Blue    Exit - Black
Lane 2 - Brown	Loop 2 – Yellow – Demand Loop	Lane 2 – Brown    Entrance - White
Lane 3 – orange	Loop 3 – Red – Passage Loop	Lane 3 – Orange
Lane 4 - Violet		Lane 4 - Violet
Lane 5 - Slate		

Lane 1 being the left lane in direction of traffic flow for mainline and ramps.

When 2 or 3 loops are installed on an exit or entrance ramp, the loop color code shall conform to the mainline loop color code and shall be marked as entrance or exit ramp loops.

Only Speed/Count Station loops, both square and rectangle, shall be color coded and tagged by lane per specific locations, as noted on plans, or as directed by the Engineer. In addition to color codes each loop shall be identified with a written label attached to the loop wire, or lead-in wire. The tags shall be Panduit #MP250W175-C or equivalent. All wires and cables shall be identified in each handhole or cabinet that the cable passes through, or terminates in. The labels shall be attached to the cable by use of two cable ties.

An electronic test instrument capable of measuring large values of electrical resistance, such as major megger, shall be used to measure the resistance of the induction loop and its lead-in. Shall be a minimum of 500 megohms above ground under any conditions of weather or moisture. The resistance tests and all electronic tests shall be performed in the presence of the Engineer any number of times specified by the Engineer. The loop and loop lead-in shall have an inductance between 50 microhenries and 1000 microhenries. The continuity test of the loop and loop lead-in shall not have a resistance greater than five (5) ohms. Testing shall be done with an approved loop tester.

Loop wire and lead-ins shall not be installed in the curb and gutter section or through the edge of pavement. A hole 1-1/2" shall be drilled at least 12" in from the edge of the pavement through which the P-Duct, loop wire, and lead-in shall be installed.

**Method of Measurement.** This work will be measured for payment in feet for the lineal footage of the loop, plus the lineal footage of the lead in to the dive/core hole.

**Basis of Payment.** This work will be paid for at the contract unit price per lineal foot as INDUCTION LOOP of the size, number and type as specified, which shall be payment in full for the work described herein. The cost of lane closures/traffic control and miscellaneous cost shall be incidental.

## **MODIFY EXISTING CONTROLLER AND CABINET**

**Description.** This work shall consist of modifying an existing controller cabinet as shown on the plans and as described herein.

**Materials.** Loop surge suppression shall be equal to or exceed the ASCO model 265 (Edco SLAC) series surge protection device.



## CONSTRUCTION REQUIREMENTS

**General Requirements.** All new induction loops are to be terminated and configured in the existing controller cabinet as shown in the plans and as described herein. New induction loops shall be supplied with new loop surge suppression. Where a single new ramp loop replaces two existing ramp loops, the Contractor shall reconfigure the existing controller inputs to reflect the new loop configuration. The Contractor shall update the existing controller sensor assignments within the controller cabinet and update the existing cabinet wiring diagram to reflect the changes. Existing loop detectors that have open channels or have channels that were previously used for loops removed under this contract can be reused if the Contractor demonstrates to the Engineer the equipment will operate properly based on the new loop configuration. If the existing controller cabinet does not have enough spare loop detection channels available to accommodate the new induction loop(s), the Contractor shall supply an additional loop detector channel that is compatible with the existing controller cabinet equipment as part of this pay item.

**Method of Measurement.** This work will be measured for payment per each controller cabinet fully modified, tested, and operational, to accommodate all new induction loops as shown on the plans.

**Basis of Payment.** This work will be paid for at the contract unit price per each for MODIFY EXISTING CONTROLLER AND CABINET, work which shall include all labor, equipment, materials, ancillary hardware, wiring, input file reconfigurations, programming, and documentation.

Integration of the new induction loops shall be paid for separately as part of the ATMS INTEGRATION pay item.

## REMOVE EXISTING UNDERGROUND CONDUIT

**Description.** This work shall consist of removing and disposing of existing underground conduit or unit duct from concrete foundation or ITS pole structure foundation conduit stub outs at the locations shown in the Plans.

## CONSTRUCTION REQUIREMENTS

All electric or fiber optic cables shall be disconnected from their source and removed prior to removing the underground conduit. Conduit entry points into the concrete foundation or ITS pole structure foundation shall be exposed and the conduit to be removed shall be cut a minimum of 2 feet from the foundation conduit stub out. Conduit shall be removed from the foundation conduit stub out to allow for new conduit to be installed into the foundation. All open trenches or excavation resulting from this work shall be backfilled to the satisfaction of the Engineer.

**Method of Measurement.** This work will be measured for payment in feet. The vertical distance of conduit removed from foundation or ITS pole structure conduit stub outs will be measured for payment in feet.

**Basis of Payment.** This work will be paid for at the contract unit price per foot removed for REMOVE EXISTING UNDERGROUND CONDUIT, which price shall include all labor, materials, excavation, and equipment required to completed the work.

**KEEPING THE EXPRESSWAY OPEN TO TRAFFIC**

Effective: March 22, 1996  
 Revised: October 9, 2020

Whenever work is in progress on or adjacent to an expressway, the Contractor shall provide the necessary traffic control devices to warn the public and to delineate the work zone as required in these Special Provisions, the Standard Specifications, the State Standards and the District Freeway details. All Contractors' personnel shall be limited to these barricaded work zones and shall not cross the expressway.

The Contractor shall request and gain approval from the Illinois Department of Transportation's Expressway Traffic Operations Engineer at [www.idotlcs.com](http://www.idotlcs.com) twenty-four (24) hours in advance of all daily lane, ramp and shoulder closures and 7 days in advance of all permanent and weekend closures on all Freeways and/or Expressways in District One. This advance notification is calculated based on workweek of Monday through Friday and shall not include weekends or Holidays.

**LOCATION: I-55: I-80 to Weber**

WEEK NIGHT	TYPE OF CLOSURE	ALLOWABLE LANE CLOSURE HOURS					
		INBOUND			OUTBOUND		
Sunday - Thursday	One Lane	8:00 PM	t o	5:00 AM	9:00 PM	t o	6:00 AM
	Two Lane	10:00 PM	t o	5:00 AM	11:00 PM	t o	6:00 AM
Friday	One Lane	9:00 PM (Fri)	t o	11:00 AM (Sat)	9:00 PM (Fri)	t o	11:00 AM (Sat)
	Two Lane	11:00 PM (Fri)	t o	9:00 AM (Sat)	11:00 PM (Fri)	t o	9:00 AM (Sat)
Saturday	One Lane	8:00 PM (Sat)	t o	11:00 AM (Sun)	8:00 PM (Sat)	t o	11:00 AM (Sun)
	Two Lane	10:00 PM (Sat)	t o	10:00 AM (Sun)	10:00 PM (Sat)	t o	10:00 AM (Sun)

**LOCATION: I-80: Kendall Co. to Center/Meadow**

WEEK NIGHT	TYPE OF CLOSURE	ALLOWABLE LANE CLOSURE HOURS					
		INBOUND			OUTBOUND		
Sunday-Thursday	1-Lane	8:00 PM	to	5:00 AM	9:00 PM	to	6:00 AM
Friday	1-Lane	8:00 PM (Fri)	to	10:00 AM (Sat)	9:00 PM (Fri)	to	10:00 AM (Sat)
Saturday	1-Lane	8:00 PM (Sat)	to	11:59 AM (Sun)	8:00 PM (Sat)	to	11:59 AM (Sun)

In addition to the hours noted above, temporary shoulder and non-system interchange partial ramp closures are allowed weekdays between 9:00 A.M. and 3:00 P.M. and between 7:00 P.M. and 5:00 A.M. or as approved by the Expressway Traffic Operations Engineer.

Narrow Lanes and permanent shoulder closures will not be allowed between Dec. 1<sup>st</sup> and April 1<sup>st</sup>. Permanent shoulder closures per District Detail TC-17 will only be permitted if called for in the plans or as approved by the Expressway Traffic Operations Engineer.

Full Expressway Closures will only be permitted for a maximum of 15 minutes at a time during the low traffic volume hours of 1:00 A.M. to 5:00 A.M. Monday thru Friday and from 1:00 A.M. to 7:00 A.M. on Sunday. During Full Expressway Closures, the Contractor will be required to close off all lanes except one, using Freeway Standard Closures. Police forces should be notified and requested to close off the remaining lane at which time the work item may be removed or set in place. The District One Expressway Traffic Control Supervisor (847-705-4151) **shall be** notified at least 3 working days (weekends and holidays DO NOT count into this 72 hours notification) in advance of the proposed road closure and will coordinate the closure operations with police forces. Liquidated Damages as specified in the Failure to Open Traffic Lanes to Traffic for One lane or ramp blocked shall be assessed to the Contract for every 15 minutes beyond the initial 15 minutes all lanes are blocked.

All stage changes requiring the stopping and/or the pacing of traffic shall take place during the allowable hours for Full Expressway Closures and shall be approved by the Department. The Contractor shall notify the District One Expressway Traffic Control Supervisor at least 3 working days (weekends and holidays DO NOT count into this 72 hours notification) in advance of any proposed stage change.

A Maintenance of Traffic Plan shall be submitted to the District One Expressway Traffic Control Supervisor 14 days in advance of any stages changes or full expressway closures. The Maintenance of Traffic Plan shall include, but not be limited to: lane and ramp closures, existing geometrics, and equipment and material location.

All daily lane closures shall be removed during adverse weather conditions such as rain, snow, and/or fog and as determined by the Engineer. Also, the contractor shall promptly remove their lane closures when Maintenance forces are out for snow and ice removal.

Additional lane closure hour restrictions may have to be imposed to facilitate the flow of traffic to and from major sporting events and/or other events.

All lane closure signs shall not be erected any earlier than one-half (1/2) hour before the starting hours listed above. Also, these signs should be taken down within one-half (1/2) hour after the closure is removed.

The Contractor will be required to cooperate with all other contractors when erecting lane closures on the expressway. All lane closures (includes the taper lengths) without a three (3) mile gap between each other, in one direction of the expressway, shall be on the same side of the pavement. Lane closures on the same side of the pavement with a one (1) mile or less gap between the end of one work zone and the start of taper of next work zone should be connected. The maximum length of any lane closure on the project and combined with any adjacent projects shall be three (3) miles. Gaps between successive permanent lane closures shall be no less than two (2) miles in length.

Private vehicles shall not be parked in the work zone. Contractor's equipment and/or vehicles shall not be parked on the shoulders or in the median during non-working hours. The parking of equipment and/or vehicles on State right-of-way will only be permitted at the locations approved by the Engineer.

Check barricades shall be placed every 1000' within a lane closure to prevent vehicles from driving through closed lanes.

Temporary ramp closures for service interchanges will only be permitted at night during the restricted hours listed for temporary one-lane closures within the project limits. However, no two (2) adjacent entrance and exit ramps in one direction of the expressway shall be closed at the same time.

Freeway to freeway (system interchange) full ramp closures for two lane ramps will not be permitted. Partial ramp closures of system ramps may be allowed during the 1-lane closure hours above. System ramp full closures for single lane ramps are only permitted for a maximum of four (4) hours

- between the hours of 1:00 a.m. and 5:00 a.m. on Monday thru Friday
- between the hours of 1:00 a.m. and 6:00 a.m. on Saturday, and
- between the hours of 1:00 a.m. and 7:00 a.m. on Sunday.

The Contractor shall furnish and install large (48" X 48") "DETOUR with arrow" signs as directed by the Engineer for all system ramp closures. In addition, one portable changeable message sign will be required to be placed in advance of the ramp closure. The cost of these signs and PCMS board shall be included in the cost of traffic control and protection (6 static signs maximum per closure).

Should the Contractor fail to completely open, and keep open, the ramps to traffic in accordance with the above limitations, the Contractor shall be liable to the Department for liquidated damages as noted under the Special Provision, "Failure to Open Traffic Lanes to Traffic".

**FAILURE TO OPEN TRAFFIC LANES TO TRAFFIC**

Effective: March 22, 1996

Revised: February 9, 2005

Should the Contractor fail to completely open and keep open all the traffic lanes to traffic in accordance with the limitations specified under the Special Provisions for "Keeping the Expressway Open to Traffic", the Contractor shall be liable to the Department for the amount of:

One lane or ramp blocked = **\$3,000.00**

Two lanes blocked = **\$6,000.00**

Not as a penalty but as liquidated and ascertained damages for each and every 15 minute interval or a portion thereof that a lane is blocked outside the allowable time limitations. Such damages may be deducted by the Department from any monies due the Contractor. These damages shall apply during the contract time and during any extensions of the contract time.

**TRAFFIC CONTROL AND PROTECTION (EXPRESSWAYS)**

Effective: March 8, 1996

Revised: January 25, 2024

Description. This work shall include furnishing, installing, maintaining, replacing, relocating, and removing all traffic control devices used for the purpose of regulating, warning, or directing traffic. Traffic control and protection shall be provided as called for in the plans, applicable Highway Standards, District One Expressway details, Standards and Supplemental Specifications, these Special Provisions, or as directed by the Engineer.

General. The governing factor in the execution and staging of work for this project is to provide the motoring public with the safest possible travel conditions on the expressway through the construction zone. The Contractor shall arrange his operations to keep the closing of lanes and/or ramps to a minimum.

The Contractor shall be responsible for the proper location, installation, and arrangement of all traffic control devices. Special attention shall be given to existing warning signs and overhead guide signs during all construction operations. Warning signs and existing guide signs with down arrows shall be kept consistent with the barricade placement at all times. The Contractor shall immediately remove, completely cover, or turn from the motorist's view all signs which are inconsistent with lane assignment patterns.

The Contractor shall coordinate all traffic control work on this project with adjoining or overlapping projects, including barricade placement necessary to provide a uniform traffic detour pattern. When directed by the Engineer, the Contractor shall remove all traffic control devices that were furnished, installed, or maintained by him under this contract, and such devices shall remain the property of the Contractor. All traffic control devices shall remain in place until specific authorization for relocation or removal is received from the Engineer.

Additional requirements for traffic control devices shall be as follows.

- (a) Traffic Control Setup and Removal. The setting and removal of barricades for the taper portion of a lane closure shall be done under the protection of a vehicle with a truck/trailer mounted attenuator and arrow board per State Standard 701428 and Section 701 of the Standard Specifications. Failure to meet this requirement will be subject to a Traffic Control Deficiency. The deficiency will be calculated as outlined in Article 105.03 of the Standard Specifications. Truck/trailer mounted attenuators shall comply with Article 1106.02(g) or shall meet the requirements of NCHRP 350 Test Level 3 with vehicles used in accordance with manufacturer's recommendations and requirements.
- (b) Sign Requirements
  - (1) Sign Maintenance. Prior to the beginning of construction operations, the Contractor will be provided a sign log of all existing signs within the limits of the construction zone. The Contractor is responsible for verifying the accuracy of the sign log. Throughout the duration of this project, all existing traffic signs shall be maintained by the Contractor. All provisions of Article 107.25 of the Standard Specifications shall apply.
  - (2) Work Zone Speed Limit Signs. Work zone speed limit signs shall be installed as required in Article 701.14(b) and as shown in the plans and Highway Standards. Based upon the existing posted speed limit, work zone speed limits shall be established and signed as follows.
    - a. Existing Speed Limit of 55mph or higher. The initial work zone speed limit assembly, located approximately 4200' before the closure, and shall be 55mph as shown in 701400. Additional work zone 45mph assemblies shall be used as required according to Article 701.14(b) and as shown in the Highway Standards and plans. WORK ZONE SPEED LIMIT 55 PHOTO ENFORCED assemblies may be omitted when this assembly would normally be placed within 1500 feet of the END WORK ZONE SPEED LIMIT sign. If existing speed limit is over 65mph then additional signage should be installed per 701400.
    - b. Existing Speed Limit of 45mph. The advance 55mph work zone speed limit assembly shown in 701400 shall be replaced with a 45mph assembly. Additional work zone 45mph assemblies shall be used as required according to Article 701.14(b) and as shown in the Highway Standards and plans. WORK ZONE SPEED LIMIT 55 PHOTO ENFORCED assemblies shall be eliminated in all cases. END WORK ZONE SPEED LIMIT signs are required.
  - (3) Exit Signs. The exit gore signs as shown in Standard 701411 shall be a minimum size of 48 inch by 48 inch with 12 inch capital letters and a 20 inch arrow. EXIT OPEN AHEAD signs shown in Standard 701411 shall be a minimum size of 48 inch by 48 inch with 8 inch capital letters.

- (4) Uneven Lanes Signs. The Contractor shall furnish and erect "UNEVEN LANES" signs (W8-11) on both sides of the expressway, at any time when the elevation difference between adjacent lanes open to traffic equals or exceeds one inch. Signs shall be placed 500' in advance of the drop-off, within 500' of every entrance, and a minimum of every mile.
- (c) Drums/Barricades. Check barricades shall be placed in work areas perpendicular to traffic every 1000', one per lane and per shoulder, to prevent motorists from using work areas as a traveled way. Check barricades shall also be placed in advance of each open patch, or excavation, or any other hazard in the work area, the first at the edge of the open traffic lane and the second centered in the closed lane. Check barricades, either Type I or II, or drums shall be equipped with a flashing light.

To provide sufficient lane widths (10' minimum) for traffic and also working room, the Contractor shall furnish and install vertical barricades, in lieu of Type II or drums, along the cold milling and asphalt paving operations. The vertical barricades shall be placed at the same spacing as the drums.

- (d) Vertical Barricades. Vertical barricades shall not be used in lane closure tapers, lane shifts, exit ramp gores, or staged construction projects lasting more than 12 hours. Also, vertical barricades shall not be used as patch barricades or check barricades. Special attention shall be given, and ballast provided per manufacture's specification, to maintain the vertical barricades in an upright position and in proper alignment.
- (e) Temporary Concrete Barrier Wall. Prismatic barrier wall reflectors shall be installed on both the face of the wall next to traffic, and the top of sections of the temporary concrete barrier wall as shown in Standard 704001. The color of these reflectors shall match the color of the edgelines (yellow on the left and crystal or white on the right). If the base of the temporary concrete barrier wall is 12 inches or less from the travel lane, then the lower slope of the wall shall also have a 6 inch wide temporary pavement marking edgeline (yellow on the left and white on the right).
- (f) Flaggers. One flagger will be required for each separate activity of an operation that requires frequent construction vehicles to enter or leave a work zone to or from a lane open to traffic. Temporary traffic control and flagger position shall be according to District One Detail TC-18 – Expressway Flagging, or as directed by the Engineer.
- (g) Full Expressway Closures. Full Expressway Closures will only be permitted for a maximum of 15 minutes during the allowable hours listed in the Keeping the Expressway Open to Traffic Special Provision. During Full Expressway Closures, the Contractor will be required to close off all lanes except one, using Freeway Standard Closures. The Contractor will be required to provide one changeable message sign to be placed at the direction of the Engineer. The sign shall display a message as directed by the Engineer. A Maintenance of Traffic Plan shall be submitted to the District One Expressway Traffic Control Supervisor 14 days in advance of the planned work; including all stage changes. The Maintenance of Traffic Plan shall include, but not be limited to: lane and ramp closures, existing geometrics, and equipment and material location. The District One Expressway Traffic Control Supervisor (847-705-4151) shall be contacted at least 3 working days in advance of the proposed road closure and will coordinate the closure operation with police forces.

Method of Measurement. This item of work will be measured on a lump sum basis for furnishing, installing, maintaining, replacing, relocating, and removing traffic control devices required in the plans and these Special Provisions. Traffic control and protection required under Standards 701101, 701400, 701401, 701406, 701411, 701428, 701901 and District details TC-8, TC-9, TC-17, and TC-18 will be included with this item.

Basis of Payment.

- (a) This work will be paid for at the contract lump sum price for TRAFFIC CONTROL AND PROTECTION (EXPRESSWAYS). This price shall be payment in full for all labor, materials, transportation, handling, and incidental work necessary to furnish, install, maintain, replace, relocate, and remove all Expressway traffic control devices required in the plans and specifications.

In the event the sum total value of all the work items for which traffic control and protection is required is increased or decreased by more than ten percent (10%), the contract bid price for TRAFFIC CONTROL AND PROTECTION (EXPRESSWAYS) will be adjusted as follows:

$$\text{Adjusted contract price} = .25P + .75P [1 \pm (X - 0.1)]$$

Where: "P" is the bid unit price for Traffic Control and Protection

Where: "X" =	=	$\frac{\text{Difference between original and final sum total value of all work items for which traffic control and protection is required}}{\text{Original sum total value of all work items for which traffic control and protection is required.}}$
--------------	---	---

The value of the work items used in calculating the increase and decrease will include only items that have been added to or deducted from the contract under Article 104.02 of the Standard Specifications and only items which require use of Traffic Control and Protection.

Temporary traffic control costs due to delay will be paid for according to the Compensable Delay Costs (BDE) Special Provision.

- (b) The Engineer may require additional traffic control be installed in accordance with standards and/or designs other than those included in the plans. In such cases, the standards and/or designs will be made available to the Contractor at least one week in advance of the change in traffic control. Payment for any additional traffic control required will be in accordance with Article 109.04 of the Standard Specifications.
- (c) Revisions in the phasing of construction or maintenance operations, requested by the Contractor, may require traffic control to be installed in accordance with standards and/or designs other than those included in the plans. Revisions or modifications to the traffic control shown in the contract shall be submitted by the Contractor for approval by the Engineer. No additional payment will be made for a Contractor requested modification.



- (d) Temporary concrete barrier wall will be measured and paid for according to Section 704.
- (e) Impact attenuators, temporary bridge rail, and temporary rumble strips will be paid for separately.
- (f) Temporary pavement markings shown on the Standard will be measured and paid for according to Section 703 and Section 780.
- (g) All pavement marking removal will be measured and paid for according to Section 703 or Section 783.
- (h) Temporary pavement marking on the lower slope of the temporary concrete barrier wall will be measured and paid for as TEMPORARY PAVEMENT MARKING, 6”.
- (i) The Changeable Message Sign required for Full Expressway Closures shall not be paid for separately.

#### **TRAFFIC CONTROL SURVEILLANCE (EXPRESSWAYS)**

Effective: October 25, 1995

Revised: January 21, 2015

The contractor shall provide a person with a vehicle to survey, inspect and maintain all temporary traffic control devices when a lane is closed to traffic, when hazards are present adjacent to or within 10 foot of the edge of pavement for more than 24 hours, or as directed by the Engineer.

The surveillance person is required to drive through the project, to inspect all temporary traffic control devices, to correct all traffic control deficiencies, if possible, or immediately contact someone else to make corrections and to assist with directing traffic until such corrections are made, at intervals not to exceed 4 hours. This person shall list every inspection on an inspection form, furnished by the Engineer, and shall return a completed form on the first working day after the inspections are made.

The Contractor shall supply a telephone staffed on a 24-hour-a-day basis to receive any notification of any deficiencies regarding traffic control and protection or receive any request for improving, correcting or modifying traffic control, installations or devices, including pavement markings. The Contractor shall dispatch additional men, materials and equipment as necessary to begin to correct, improve or modify the traffic control as directed, within one hour of notification by this surveillance person or by the Department. Upon completion of such corrections and/or revisions, the Contractor shall notify the Department's Communication Center at (847) 705-4612.

Method of Measurement.

Traffic Control Surveillance will be measured on calendar day basis. One calendar day is equal to a minimum of six (6) inspections. The inspections shall start within 4 hours after the lane is closed to traffic, a hazard exists within 10 foot from the edge of pavement, or as directed by the Engineer and shall end when the lane closure or hazard is removed or as directed by the Engineer.

Basis of Payment.

Surveillance will be paid for at the contract unit price per calendar day or fraction thereof for TRAFFIC CONTROL SURVEILLANCE (EXPRESSWAYS). The price shall include all labor and equipment necessary to provide the required inspection and maintenance on the expressway and on all cross streets which are included in the project. The cost of the materials for the maintenance of traffic control devices shall be included in the traffic control pay items.

**TEMPORARY INFORMATION SIGNING**

Effective: November 13, 1996

Revised: January 29, 2020

Description.

This work shall consist of furnishing, installing, maintaining, relocating for various states of construction and eventually removing temporary informational signs. Included in this item may be ground mount signs, skid mount signs, truss mount signs, bridge mount signs, and overlay sign panels which cover portions of existing signs.

Materials.

Materials shall be according to the following Articles of Section 1000 - Materials:

	<u>Item</u>	<u>Article/Section</u>
a.)	Sign Base (Note 1)	1090
b.)	Sign Face (Note 2)	1091
c.)	Sign Legends	1091
d.)	Sign Supports	1093
e.)	Overlay Panels (Note 3)	1090.02

Note 1. The Contractor may use 5/8 inch (16 mm) instead of 3/4 inch (19 mm) thick plywood.

Note 2. The sign face material shall be in accordance with the Department's Fabrication of Highway Signs Policy.

Note 3. The overlay panels shall be 0.08 inch (2 mm) thick.

## **GENERAL CONSTRUCTION REQUIREMENTS**

### Installation.

The sign sizes and legend sizes shall be verified by the Contractor prior to fabrication.

Signs which are placed along the roadway and/or within the construction zone shall be installed according to the requirements of Article 701.14 and Article 720.04. The signs shall be 7 ft (2.1 m) above the near edge of the pavement and shall be a minimum of 2 ft (600 mm) beyond the edge of the paved shoulder. A minimum of two (2) posts shall be used.

The attachment of temporary signs to existing bridges, sign structures or sign panels shall be approved by the Engineer. Any damage to the existing signs and/or structures due to the Contractor's operations shall be repaired or signs replaced, as determined by the Engineer, at the Contractor's expense.

### Method of Measurement.

This work shall be measured for payment in square feet (square meters) edge to edge (horizontally and vertically).

All hardware, posts or skids, supports, bases for ground mounted signs, connections, which are required for mounting these signs will be included as part of this pay item.

### Basis Of Payment.

This work shall be paid for at the contract unit price per square foot (square meter) for TEMPORARY INFORMATION SIGNING.

## **TRAFFIC CONTROL FOR WORK ZONE AREAS**

Effective: September 14, 1995

Revised: January 1, 2007

Work zone entry and exit openings shall be established daily by the Contractor with the approval of the Engineer. All vehicles including cars and pickup trucks shall exit the work zone at the exit openings. All trucks shall enter the work zone at the entry openings. These openings shall be signed in accordance with the details shown elsewhere in the plans and shall be under flagger control during working hours.

The Contractor shall plan his trucking operations into and out of the work zone as well as on to and off the expressway to maintain adequate merging distance. Merging distances to cross all lanes of traffic shall be no less than 1/2 mile. This distance is the length from where the trucks enter the expressway to where the trucks enter the work zone. It is also the length from where the trucks exit the work zone to where the trucks exit the expressway. The stopping of expressway traffic to allow trucks to change lanes and/or cross the expressway is prohibited.

Failure to comply with the above requirements will result in a Traffic Control Deficiency charge. The deficiency charge will be calculated as outlined in Article 105.03 of the Standard Specifications. The Contractor will be assessed this daily charge for each day a deficiency is documented by the Engineer.

**SPEED DISPLAY TRAILER (D1)**

Effective: April 1, 2015

Revised: April 1, 2021

Revise the third paragraph of Article 701.11 of the Standard Specifications to read:

“When not being utilized to inform and direct traffic, sign trailers, speed display trailers, arrow boards, and portable changeable message boards shall be treated as nonoperating equipment.”

Add the following to Article 701.15 of the Standard Specifications:

“(m) Speed Display Trailer. A speed display trailer is used to enhance safety of the traveling public and workers in work zones by alerting drivers of their speed, thus deterring them from driving above the posted work zone speed limit.”

Whenever the speed display trailer is not in use, it shall be considered non-operating equipment and shall be stored according to Article 701.11.”

Add the following to Article 701.20 of the Standard Specifications:

“(k) “Speed Display Trailer will NOT be paid for by separate pay item, but its costs shall be included in the contract unit price of the various traffic control pay items.

Add the following to Article 1106.02 of the Standard Specifications:

“(o) Speed Display Trailer. The speed display trailer shall consist of a LED speed indicator display with self-contained, one-direction radar mounted on an orange see-through trailer. The height of the display and radar shall be such that it will function and be visible when located behind concrete barrier.

The speed measurement shall be by radar and provide a minimum detection distance of 1000 ft (300 m). The radar shall have an accuracy of  $\pm 1$  mile per hour.

The speed indicator display shall face approaching traffic and shall have a sign legend of “YOUR SPEED” immediately above or below the speed display. The sign letters shall be between 5 and 8 in. (125mm and 200 mm) in height. The digital speed display shall show two digits (00 to 99) in mph. The color of the changeable message legend shall be a yellow legend on a black background. The minimum height of the numerals shall be 18 in. (450 mm), and the nominal legibility distance shall be at least 750 ft (250 m).

The speed indicator display shall be equipped with a violation alert that flashes the displayed detected speed when the posted limit is exceeded. The speed indicator shall have a maximum speed cutoff. On roadway facilities with a normal posted speed limit greater than or equal to 45 mph, the detected speeds of vehicles traveling more than 25mph over the work zone speed limit shall not be displayed. On facilities with normal posted speed limit of less than 45 mph, the detected speeds of vehicles traveling more than 15 mph over the work zone speed limit shall not be displayed. On any roadway facility if detected speeds are less than 25 mph, speed shall not be displayed. The display shall include automatic dimming for nighttime operation.

The speed indicator measurement and display functions shall be equipped with the power supply capable of providing 24 hours of uninterrupted service.”

### **RAISED REFLECTIVE PAVEMENT MARKER, REFLECTOR REMOVAL**

Effective: August 1, 2023

Revised:

Description: This work shall be completed in accordance with Section 783 of the Standard Specifications for Road and Bridge Construction. This work shall consist of removing the reflector unit from existing raised reflector pavement markers that will remain in place at the end of construction activities. Existing reflectors that conflict with revised traffic patterns shall be removed immediately to facilitate a change in lane assignment. If darkness or inclement weather prohibits the removal operations, such operation shall be resumed the next morning of when weather permits.

The base casting shall remain in place in areas where no pavement rehabilitation is required, therefore only the reflector shall be removed. Debris from the removal operations shall be removed from the pavement prior to opening the roadway to traffic.

Basis of Payment: This work will be measured for payment at the contract unit price per each for RAISED REFLECTIVE PAVEMENT MARKER, REFLECTOR REMOVAL. Payment shall be full compensation for materials, labor and equipment required to complete this work.

**RAISED REFLECTIVE PAVEMENT MARKER, REFLECTOR REPLACEMENT**

Effective: August 1, 2023

Revised:

Description: This work shall be completed in accordance with Section 781 of the Standard Specifications for Road and Bridge Construction. This work shall consist of reinstallation of reflectors into the raised pavement marker castings upon completion of staging in which the markers were in conflict with temporary lane usage.

Basis of Payment: This work will be measured for payment at the contract unit price per each for RAISED REFLECTIVE PAVEMENT MARKER, REFLECTOR REPLACEMENT. Payment shall be full compensation for materials, labor and equipment required to complete this work.

**MAST ARM SIGN PANELS**

Effective: May 22, 2002

Revised: July 1, 2015

720.01TS

Add the following to Article 720.02 of the Standard Specifications:

Sign stiffening channel systems shall be aluminum and meet the requirements of ASTM 6261-T5. Sign mounting banding, buckles and buckle straps shall be manufactured from AISI 201 stainless steel.

**SIGN SHOP DRAWING SUBMITTAL**

Effective: January 22, 2013

Revised: July 1, 2015

720.02TS

Add the following paragraph to Article 720.03 of the Standard Specifications:

Shop drawings will be required, according to Article 105.04, for all Arterials/Expressways signs except standard highway signs covered in the MUTCD. Shop drawings shall be submitted to the Engineer for review and approval prior to fabrication. The shop drawings shall include dimensions, letter sizing, font type, colors and materials.

**OVERHEAD SIGN STRUCTURE – BRIDGE MOUNTED**

Effective: July 1, 2015  
Revised: March 1, 2017

Revise Article 733.10(b) of the Standard Specification to read:

“Sign Structure – Bridge Mounted. Bridge mounted overhead sign structures will be measured for by payment in feet (meters) of the overall width of the sign panel or total width of adjacent sign panels, including spacing between adjacent sign panels, to be installed on the sign structure.”

**COARSE SAND PLACEMENT**

Effective: February 7, 2007

**Description.** This work shall consist of furnishing, transporting, spreading, and incorporating Coarse Sand (FA 2) into the soil in areas shown on the plans and as directed by the Engineer.

**Materials.** Materials shall meet the requirements of the following Article of Section 1000 – Materials:

(a) Fine Aggregate.....1003.04

**Method.** Coarse Sand shall not be placed until the area designated has been shaped, trimmed, and finished in accordance with Section 212 of the Standard Specifications and any required placement of Topsoil has been completed. Prior to Coarse Sand placement, the area shall be disked or raked to a minimum depth of 4 inches (100 mm) and all debris and loose stones removed. The grades and condition of the area must be approved by the Engineer prior to Coarse Sand placement.

The Coarse Sand shall be placed in the planting beds to the depth specified. After the Engineer verifies that the proper Coarse Sand depth has been applied, the Contractor shall completely incorporate the sand into the soil to a minimum depth of 6 inches (150 mm) by raking, disking, or roto tilling to amend the existing topsoil.

After the Coarse Sand has been incorporated into the soil, any debris or piles of unincorporated material shall be immediately removed from the right-of-way and the area finished to the lines and grades shown on the plans and approved by the Engineer. Disposal of material shall be done in accordance with Article 202.03.

**Method of Measurement.** Coarse Sand Placement will be measured in square yards (square meters) at the location shown in the plans and as directed by the Engineer prior to incorporation into the soil.

**Basis of Payment.** This work will be paid for at the contract unit price per square yards (square meters) for COARSE SAND PLACEMENT of the thickness specified.

## **ABANDON EXISTING CULVERT**

**Description.** This work shall consist of the abandonment and filling of existing concrete culverts at the locations specified in the plans or as directed by the Engineer.

**Materials.** The interior of the culvert shall be filled with controlled low-strength material in accordance with Sections 593 and 1019 of the Standard Specifications. The openings of the culvert shall either be sealed with Class SI concrete in accordance with Section 1020, or with brick or masonry units in accordance with Article 1042.15 of the Standard Specifications.

**General.** Filling shall begin at the upstream end of the existing culvert to be abandoned. Any vent holes used for introduction of material shall be plugged and filled as soon as possible after daily operations are complete. Culvert abandonment work shall be completed after the proposed culverts have been installed and are operational.

**Removal.** Prior to filling operations, the contractor shall remove and dispose of the existing concrete headwalls.

**Submittals.** At least 15 days prior to beginning construction, the contractor shall submit a written work plan for the abandonment of the culvert to the Engineer for approval. This plan shall address the proposed work sequence, including concrete removal, drilling of vent holes and their locations, and any necessary traffic control. The work plan shall be supplemented with sketches as necessary.

**Basis of Payment.** This work will be paid for at the contract unit price per each for ABANDON EXISTING CULVERT. Concrete headwall removal work will be paid for at the contract unit price per each for CONCRETE HEADWALL REMOVAL.

## **CONCRETE BARRIER BASE (SPECIAL)**

**Description.** This work shall consist of constructing a concrete barrier base with reinforcement bars below a concrete barrier wall as detailed in the plans.

**Construction Requirements.** This work shall be done in accordance with the applicable portions of Section 637 of the Standard Specifications. The concrete barrier base shall be constructed as detailed in the plans. The concrete barrier wall shall be constructed separately and not poured monolithically with the concrete barrier base.

**Method of Measurement.** CONCRETE BARRIER BASE (SPECIAL) per the number indicated on plans will be measured for payment in feet in place along the centerline of the barrier base. The concrete barrier wall of the type specified will be paid for separately in accordance with the special provision for CONCRETE BARRIER of the type specified.

**Basis of Payment.** This work will be paid for at the contract unit price per foot for CONCRETE BARRIER BASE (SPECIAL) per the number indicated on plans, which price shall include all equipment, labor, and materials necessary to construct the concrete barrier base including all reinforcement bars in the concrete barrier base and those extending into the concrete barrier wall or concrete barrier transition, and epoxy coated tie bars.



### **CONCRETE BARRIER, VERTICAL FACE (SPECIAL)**

**Description.** This work shall consist of constructing a concrete barrier wall as detailed in the plans.

**Construction Requirements.** This work shall be done in accordance with the applicable portions of Section 637 of the Standard Specifications. The concrete barrier wall shall be constructed on a concrete barrier base as detailed in the plans.

**Method of Measurement.** Concrete barrier walls shall be measured for payment in feet in place, along the centerline of the concrete barrier. Concrete barrier base will be paid for separately according to CONCRETE BARRIER BASE (SPECIAL).

**Basis of Payment.** This work will be paid for at the contract unit price per foot for CONCRETE BARRIER, VERTICAL FACE (SPECIAL); or as shown in the plans. This contract unit price shall include all equipment, labor and materials necessary to construct the concrete barrier wall including all reinforcement bars in the concrete barrier wall.

### **EMBANKMENT TESTING FOR MSE WALL CONSTRUCTION**

Description. This work shall consist of performing additional tests to verify the compaction properties of embankment fill are achieved in locations where MSE walls are expected to be established on newly placed embankments. This work shall be according to Section 205 of the Standard Specifications except for the following.

Material. Fill material shall be free of organic matter and debris and placed in lifts and compacted according to Section 205 of the Standard Specification. All materials shall be approved by the Engineer.

Requirements. The MSE wall (SN099-W1003) located along Ramp AA between Station 27+30 and Station 29+00 is expected to be established on newly placed embankment. The applied equivalent bearing pressures vary from 3,200 to 3,800 psf for this MSE wall location.

The in-place bearing stratum for the MSE wall reinforced zone shall be checked to verify the in-situ condition for availability of equivalent bearing pressure. The new embankment within this area shall be constructed to achieve a minimum unconfined compressive strength (Qu) of at least 2 tsf and shall be verified in the field at the time of embankment fill placement.

The embankment construction shall be compacted to the satisfaction of the Qualified Soil Inspector.

The embankment fill shall be tested with a Dynamic Cone Penetrometer (DCP) to determine the unconfined compressive strength (Qu) of foundation materials. The DCP test shall be conducted according to Illinois Test Procedure 501, of IDOT's Manual of Test Procedures for Materials (17).

Basis of Payment. This work will not be paid separately but will be considered as included in the various items of excavation.

## **EXPRESSWAY SWEEPING CYCLE**

Description. This work shall consist of the sweeping, pickup, removal and satisfactory disposal of all debris, refuse, and other rubbish which has accumulated on the highway. Areas to be cleaned are those driving surfaces including expressway, expressway ramp and local street pavement, expressway, expressway ramp and local street shoulders and crash investigation sites within the project limits. All work will be done at night according to the KEEPING THE EXPRESSWAY OPEN TO TRAFFIC special provision. This work shall include the traffic control required to close lanes necessary for the sweeping work. Moving lane closures per IDOT State Standard 701426 will not be permitted. Lanes shall be closed per IDOT State Standards 701400, 701401, 701428, 701446, and as directed by the Engineer. Sweeping will be required once every other month starting within 30 days of contract award until substantial completion of the project or as directed by the engineer.

Because sweeping operations need water to work effectively, sweeping will not be allowed when temperatures or wind chill factors are forecasted by the Departments certified meteorologists to be at or below freezing. Temperature must be above 32 degrees Fahrenheit. All shoulders and curb lines must be free of any existing snow and/or ice. Dry sweeping shall be allowed only if it is considered an emergency, immediate hazard, or any work as designated by the department that requires first priority corrective action.

### Sequence of Work.

The Contractor shall submit a sequence of work for the full expressway sweeping cycle. The sequence of work shall be approved by the Engineer prior to commencing operations. It is required that the cleaning be completed to the satisfaction of the Engineer.

Each cycle shall consist of sweeping the length for Contract 62R26 which has been determined to be:

Northbound I-55:	1.5 miles
Southbound I-55:	1.5 miles
I-80/I-55 Interchange Ramp B:	0.2 miles
I-80/I-55 Interchange Ramp D:	0.4 miles
I-80/I-55 Interchange Ramp AA:	0.3 miles
 Total Miles Per Cycle:	 3.9 miles

Method of Measurement. This work shall be measured for payment per EACH cycle of sweeping.

Basis of Payment. This work shall be paid for at the contract unit prices per EACH cycle for EXPRESSWAY SWEEPING CYCLE which price shall include the labor, equipment and materials necessary to perform the work as herein specified and as directed by the Engineer.

## **FENCE REMOVAL**

**Description.** This work shall consist of the removal of the existing fence, which may or may not include barb wired strands at those locations shown on the plans.

**General.** The fence removal shall include the removal of existing fencing of various materials, posts and foundations in their entirety.

The existing fence shall be removed in a logical sequence, and with continuity, ahead of fence replacement, at a distance that will not result in unusually long delays between fence removal and new fence replacement. At the end of each day's work or whenever no work is being performed in the areas that have had the fence removed, a temporary fence shall be installed by the Contractor. This temporary fence may be snow fence, or other fence material approved by the Engineer. Temporary fencing shall be kept to a minimum and shall be inspected daily by the Contractor. Maintenance shall be checked daily and kept up by the Contractor so long as the temporary fence is in use. Permanent and temporary fence ends shall be securely fastened together by steel wire in such a manner as to prevent casual dismantling of the temporary fence. No gaps shall be left between ends of the fence. There shall be no additional compensation for furnishing and installing temporary fence as herein specified.

The resulting void from the removal of the post or foundation holes shall be backfilled with compacted (hand tamped as a minimum) course aggregate material (CA-6, CA-10 or CA-12). If the holes are in turf, areas at finished grade they shall be capped with four (4) inches of topsoil graded to match existing ground. Any ruts resulting from these operations shall be filled with topsoil and graded smooth. No additional compensation shall be made for the off-site disposal of materials and for filling of foundation holes or ruts.

Existing posts which are set in concrete may be sawed off flush with the top of the concrete foundations. After the alignment of the new fence has been established and new posts are in place, the Contractor has the option of totally removing the old fence posts and foundations or removing the old fence posts and foundations a minimum of 6" below the existing ground elevation. No old fence posts and foundations are to remain in place upon completion of the new fence. All the holes from the old fence foundations shall be filled with natural sand. The top 6" shall be filled with topsoil.

Any damage to public or private property which results from the removal of existing fence shall be repaired by the Contractor to the satisfaction of the Engineer at no additional cost.

**Method of Measurement.** This work will be paid for payment in feet, in place and standing prior to removal.

**Basis of Payment.** This work will be paid for at the contract unit price per foot for FENCE REMOVAL.

## **GAS/OIL PIPELINE PROTECTION**

**Description.** This item consists of the coordination of work performed within 25-feet of the existing TC Energy and Enbridge pipelines and for the protection of the existing facilities owned, operated, and maintained by TC Energy and Enbridge.

Existing TC Energy facilities identified within this contract include a 30" pipeline crossing Ramp B at a skew at STA. 997+98.70 and a 22" pipeline (in a 24" casing) crossing Ramp B at STA. 998+31.1.

Existing Enbridge facilities identified within this contract include a 24" pipeline crossing Ramp B at a skew at STA. 999+39.6.

**General.** Work performed within 25-feet of the existing gas and oil pipelines shall be performed in accordance to the Standard Specifications and additional requirements set forth by the respective utility to protect the safety of the existing facilities.

The depth and locations of the existing pipelines at the proposed crossings shall be verified in the field prior to installation of the proposed improvements.

Work within the 25-foot construction envelope of the TC Energy pipeline shall be adjusted to comply with the TC Energy General Guidelines included as Attachment "A" to protect the safety of TC Energy's facilities. Guidelines, although not inclusive, are provided by TC energy to protect the pipelines and facilities.

**Equipment.** Equipment may be limited when performing work within 25-feet of the respective pipelines or related facilities.

### TC Energy Specified Limitations of Equipment.

The Contractor shall submit to TC Energy for approval a Heavy Equipment Crossing Information Form (Attachment "B") for all equipment that will operate within 25-feet of the TC Energy pipelines or related facilities. No equipment will be permitted near the existing facilities without prior approval from TC Energy.

The permittee will work with the on-site representative to complete the Heavy Equipment Crossing Information Form. The Contractor shall furnish to the Engineer a copy of the approved Heavy Equipment Crossing Information Form at least one working day prior to starting work within 25-feet of the TC Energy pipelines.

Refer to Attachment "A." TC Energy General Guidelines for additional equipment limitations.

## CONSTRUCTION REQUIREMENTS

**General.** The construction methods performed within 25-feet of the gas and oil pipelines shall adhere to the additional requirements set forth by the respective utility, approved by the Utility's Designated Representative or as directed by the Engineer.

### TC Energy Specified Construction Requirements.

The Contractor shall notify TC Energy at least seventy-two (72) hours in advance of construction. The TC Energy contact person is:

Chad Klatt (815) 826-0987

The Contractor shall submit to TC Energy for approval an **Application to Work on or Within 100 ft of TC Energy ROW (US)** (Attachment "C"). The Contractor shall furnish to the Engineer a copy of the approved **Application to Work on or Within 100 ft of TC Energy ROW (US)** at least one working day prior to starting work within 100 feet of TC Energy pipelines and related facilities.

A copy of the TC Energy General Guidelines shall be onsite at all times (Attachment "A"). All construction workers and equipment operators shall be made aware of the requirements of this special provision and TC Energy General Guidelines prior to starting work. This letter is included at the end of this special provision. The Contractor shall implement the requirements stated in the letter specific to each Encroachment in addition to the requirements of this special provision. In the case of any conflict between the approval letter and this special provision, the requirements of this special provision shall govern.

Concerns expressed by the TC Energy representative may be considered by the Engineer as the basis for suspension of work in accordance with Article 108.07.

The Contractor shall include a coordination meeting with the Engineer and TC Energy representative in the Progress Schedule in accordance with Article 108.02. The meeting shall be held at least 30 calendar days prior to beginning work within TC Energy Pipeline ROW. The meeting will be held onsite at the Engineer's field office. The Contractor's superintendent shall attend this meeting. No work shall occur within the TC Energy ROW until after the meeting is held.

Enbridge Construction Requirements.

NO VIBRATION ZONE and NO HAMMERING REMOVAL methodologies shall be allowed within 20 ft of the Enbridge pipeline for any proposed roadway removal and construction.

The depth to the top of Enbridge pipelines at proposed crossings shall be verified in the field prior to installation. The final depth of cover to the existing pipeline shall have a minimum of 4 ft. Conduits for lighting shall maintain a minimum of 2 ft clearance to the existing pipeline.

The Contractor shall notify Enbridge at least seventy-two (72) hours in advance of construction. The Enbridge contact person is:

Troy Toweson (219) 793-3214

**Excavation.** The Permittee shall mark any excavation area with white paint, flags, or as required by applicable state law within a minimum of 25-feet to the TC Energy and Enbridge pipelines and related facilities.

Before excavation can begin within 25-feet of TC Energy or Enbridge pipelines and related facilities., the excavation area must be located and marked in according to the appropriate state one call regulation. Safe digging is no accident. Know what's below. Call 811 before you dig. TC Energy, Enbridge or designated representative shall locate the pipeline and determine the approximate depth of cover before the Contractor can begin excavation.

**Miscellaneous.** The Contractor shall maintain a communications log of telephone calls, emails, and all other contacts with TC Energy and Enbridge. A photograph log shall be created daily showing the equipment and operations within 25-feet of the pipeline. Each photograph shall have a caption describing the location of the photograph, the equipment and operations shown in the photograph, and the date of the photograph. The Contractor shall furnish to the Engineer a copy of the communications and photograph logs weekly no more than one working day after the end of the previous week.

Should the design require a field change in the vicinity of the TC Energy or Enbridge pipelines, the appropriate utility representative must be contacted and approve any revisions prior to actuating the changes in the field.

The Contractor shall furnish to the Engineer as-built drawings of all improvements within the TC Energy and Enbridge right-of-way within 10 working days of all work within the pipeline right-of-way being completed. As-builts shall consist of two sets of hardcopies and two CDs or flash drives with scanned PDFs of the hardcopies showing the actual locations and extents of completed work.

**Method of Measurement.** Work required to comply with the requirements of this special provision will be measured on a lump sum basis.

Earth excavation will be measured separately for payment in accordance with Article 202.07.

Removal and disposal of unsuitable material will be measured separately for payment in accordance with Article 202.07.

**Basis of Payment.** This work will be paid for at the contract lump sum for GAS/OIL PIPELINE PROTECTION which payment shall be full compensation for the work described herein and as directed by the Engineer.

Earth excavation will be paid for separately in accordance with Article 202.08.

Removal and disposal of unsuitable material will be paid for separately in accordance with Article 202.08.

**Attachment "A." TC Energy General Guidelines**



*Issued: 10-12-2023*

***Involvement status relates solely to facilities owned and/or operated by TC Energy.***

Work within the TC Energy's right-of-way will be performed in accordance with TC Energy procedures to protect the safety of TC Energy's facilities. The following guidelines, although not inclusive, are provided to accommodate your request and protect our pipelines and facilities.

**Section 1: General Requirements for Construction within TC Energy Right-of-Way (ROW).**

1. Follow all applicable federal and state safety requirements at all times.
2. Before any preliminary field work or construction begins in the vicinity of TC Energy pipeline facilities the approximate location and elevation of the pipeline shall be investigated. Begin with a call to 811 or appropriate state "One Call" notification number. Request both the approximate location and depth of the pipeline to be determined in any area of proposed construction. The area of proposed construction shall be marked with white paint, flags, or otherwise as required by state law.
3. When conducting construction activities in or around TC Energy pipeline facilities or rights-of-way, a TC Energy on-site Company Representative shall be present unless otherwise permitted by TC Energy. A TC Energy Representative will review the location of pipeline facilities prior to starting work.
4. Notice of at least seventy-two (72) hours in advance of construction must be provided.
5. Permittee shall notify the responsible State "One Call" center to request that TC Energy re-mark a pipeline if the existing markers are inadequate or no longer visible for any reason, including disturbance due to construction activities.
6. Permittee shall not burn or bury trash, brush, or other items or substances within TC Energy pipeline rights-of-way.
7. Permittee shall not park equipment or store materials on the TC Energy right-of-way.
8. Use of vibratory equipment larger than walk-behind units shall not be permitted within twenty-five (25) feet of the pipeline or related facility.
9. The Permittee shall mark any excavation area with white paint, flags, or as required by applicable state law within TC Energy right-of-way.





10. The following items, but not limited to, are not permitted within the ROW; valves, curb boxes, manholes, sprinkler heads, splice boxes, service risers, energized equipment, poles, towers, guy wires, mechanical supports, ground rods, anchors, signs, bollards, and similar structures.
11. Before excavation can begin near a TC Energy right-of-way, the excavation area must be located and marked in according to the appropriate state one call regulation. Safe digging is no accident. Know what's below. Call 811 before you dig. TC Energy or its representative shall locate the pipeline and determine the approximate depth of cover before the Permittee can begin excavation.
12. TC Energy shall have a Company representative present during all excavation activities. The Company representative shall have full authority to stop the work if it is determined that the work is being performed in an unsafe manner relative to TC Energy facilities or personnel.
13. Should it be necessary for a TC Energy employee/representative to enter the excavation to inspect its pipeline(s), the excavation at the crossing shall be sloped, permitted safe with trench boxes, or shored in accordance with the requirements of the Occupational Safety and Health Administration.
14. No equipment shall work directly over the pipeline, unless TC Energy grants specific written permission.
15. When excavating within a TC Energy right-of-way, in the presence of a loaded pipeline, the Permittee's excavation equipment shall have a plate welded or attached over the teeth of the excavator bucket.
16. No side cutters shall be used during any excavation within a TC Energy ROW.
17. No part of powered equipment shall come within two (2) feet of TC Energy's pipelines, or according to applicable State or Federal requirements.
18. No bucket, any attachment or load may be swung over TC Energy's pipeline(s) where there is less than two (2) feet of cover.
19. TC Energy requires the pipeline to be potholed prior to excavation within fifteen (15) feet. Afterwards potholing techniques are to be used when digging within two (2) feet of the outer edge of the pipe, unless requirements that are more stringent are set forth by the applicable state's One Call system. Within this "tolerance zone" only hand excavation, air cutting, vacuum excavation or other TC Energy approved techniques are permitted.
20. No excavation shall be made on land adjacent to the pipeline that shall in any way impair, withdraw lateral support, cause subsidence, create the accumulation of water, or cause damage to the pipeline or right-of-way.



21. The Permittee shall ensure all excavation work complies with OSHA's excavation standards outlined in 29 CFR 1926 and correct any noncompliant excavation site before work within TC Energy right-of-way continues.
22. At any location where the pipeline is exposed, the Permittee shall provide TC Energy the opportunity to inspect the pipeline condition, install cathodic protection equipment, repair any pipe coating imperfections, and/or install underground warning materials.
23. No TC Energy buried pipeline shall be left exposed for any duration of time, unless otherwise permitted by TC Energy.
24. Backfill and compaction shall be performed to the satisfaction and in the presence of a Company representative. At least 6 inches of fine, loose earth or other permitted backfill material with no sharp gravel, rock, hard clods, vegetation, or other debris shall be added on all sides of any pipeline, and remaining backfill shall be placed so as not to disturb this padding material or damage the pipeline and its coating. Backfill over the pipe shall be compacted by hand until eighteen (18) inches of cover is achieved.
25. If a flowable fill is required by TC Energy to achieve necessary compaction and support under and around the pipe, specifications will be provided after drawing review and approval.
26. Disturbed ground shall be compacted to at least the same degree of compaction as surrounding areas.
27. The Permittee shall restore the site to its original condition unless otherwise permitted by TC Energy.
28. Continuously poured, steel reinforced concrete is not permitted within TC Energy right-of-way.
29. There shall be no work or spoil storage on the TC Energy right-of-way, nor shall there be any unauthorized equipment crossing(s) on the TC Energy right-of-way.
30. The permittee may be crossing one or more of TC Energy's transmission pipeline(s). These pipeline(s) may be coated with a material to protect them from corrosion. The coating may contain asbestos. If the excavation results in exposing TC Energy's pipeline(s) and there is any damage to the coating, you will be responsible for all costs, including any disposal costs, associated with the coating repair. If necessary, you will also be required, to halt all work activity while the coating material is being analyzed. The coating repair, including the removal of the original material, will be performed by TC Energy personnel or a qualified third-party contractor selected by TC Energy. All work will be done in accordance with TC Energy's current engineering and environmental standards. During





the course of the excavation work, Permittee agrees to cooperate with TC Energy to ensure all federal, state and local environmental and safety regulations are followed.

31. The permittee shall submit a Heavy Equipment Crossing Information Form for **all additional** equipment that will operate within the TC Energy right-of-way. No additional equipment will be permitted within the right-of-way without prior approval from TC Energy. The permittee will work with the on-site representative to complete the Heavy Equipment Crossing Information Form.
32. While using the permitted crossing area(s) with heavy equipment, if rutting, any form of ground decay, or ground pumping occurs, additional measures will be required. The additional measures will include but are not limited to: load calculation reassessment, matting/air bridge installment, additional cover, concrete relief slabs, etc.
33. TC Energy shall limit the number of temporary construction roads constructed by the Permittee. Crossings shall be limited to pre-selected sites and shall be clearly defined and marked. Random crossings are not permitted. The Permittee shall install temporary fencing along the TC Energy right-of-way boundaries so equipment shall not inadvertently pass over the pipeline at locations other than those established for the crossing.
34. During the use of a permitted temporary construction road, the Permittee shall take all reasonable and necessary steps to maintain the integrity of the permitted crossing protection. TC Energy personnel should inspect crossings periodically and may require the Permittee to provide additional protective measures deemed necessary to prevent damage to the pipeline or right-of-way.

## **Section 2: Requirements for Construction of Roads, Sidewalks, Parking, and Grading**

35. All proposed road crossings of buried facilities must be evaluated by TC Energy. Protective measures may be required before construction activity can begin or during the course of such construction activity.
36. Roads, driveways, and concrete sidewalks are not permitted to be installed longitudinally within the ROW.
37. Use of vibratory equipment larger than walk-behind units shall not be permitted within twenty-five (25) feet of the pipeline or related facility.
38. Variance of the existing depth of cover is not permitted without TC Energy's written permission. Protective measures may be required before construction activity can begin or during the course of such construction activity.



39. Where additional cover is permitted, the final grading shall meet a minimum cover of three (3) feet over the pipeline but shall not exceed five (5) feet from the top of the pipeline without TC Energy written permission.
40. Detention or retention ponds, lakes, structures or any type of impoundment of water, temporary or permanent, shall not be permitted within the right-of-way.
41. Any modifications to an existing drainage pattern shall be designed so there is no erosion of the cover over TC Energy right-of-way. The Permittee shall provide engineering documentation for water velocity calculations verifying no erosion will occur.
42. For drainage channels and ditches where a minimum cover of three (3) feet cannot be maintained, the Permittee shall be responsible for the cost of installation of additional protection required by TC Energy.
43. Roads, driveways, or sidewalks shall cross the right-of-way at as near to ninety (90) degrees as possible, but no less than forty-five (45) degrees.
44. Venting systems shall not be used as a means to extend crossovers or vent parking lots.
45. Concrete sidewalks and/or curbs, shall have expansion joints installed five(5) feet on either side of the pipeline.
46. Asphalt roads must not be greater than twenty-five (25) feet in width, or the minimum width required by local and/or state regulations. Permittee must submit documentation when requesting road widths exceeding twenty-five (25) feet.
47. Asphalt pavement shall not be installed closer than five (5) feet from the pipeline except in the case of roadway, driveway, or parking lot crossovers. Where parking areas are permitted within the ROW, barriers must be installed on the edge of the parking area closest to the pipeline.
48. Parking area(s) shall not be installed within ten (10) feet of TC Energy pipeline facilities.
49. Barriers shall be installed on the edge of the parking area closest to the pipeline.
50. Parking lot “crossovers” may be permitted by TC Energy and shall be no greater than twenty-five (25) feet in width.
51. Parking lot “crossovers” shall be spaced at a minimum of fifty (50) foot intervals (measured from the edge of the crossover). Where fifty (50) feet cannot be maintained additional measures may be required.

### **Section 3: Requirements for Walking and Bicycle Paths**





52. Walking/bicycling paths shall be constructed at the outside edge of the TC Energy permanent right-of-way area.
53. Longitudinal path width within TC Energy rights-of-way shall not exceed six (6) feet.
54. Paths shall cross the TC Energy pipeline as close to ninety (90) degrees as possible, but no less than forty-five (45) degrees.
55. No motorized vehicles of any type, other than power driven wheelchairs, shall utilize paths, which run longitudinally inside the right-of-way.
56. Paving shall be restricted to asphalt only. No concrete paving shall be used for walking and paths.
57. Landowner shall be responsible for maintaining the path to prevent right-of-way damage (including erosion, illegal dumping, etc.) Any change in grade or modifications to existing grade required to control erosion shall be reviewed and approved by TC Energy

**Section 4: Requirements for Construction of Retaining Walls, Fences, Buildings, and Landscaping**

58. Buildings or other structures, including but not limited to overhanging balconies, patios, decks, swimming pools, wells, walls, utility poles, septic systems, propane tanks, transformer pads, or the storage of materials which creates an obstruction or prevents the inspection of the right-of-way by air or foot, shall not be permitted within the TC Energy right-of-way.
59. The Permittee shall not build retaining walls, drive piling or sheeting, or install an engineered structure that may negatively impact the TC Energy right-of-way.
60. The right-of-way area may be planted in lawn, flowerbeds, or vegetable gardens, or used for normal agricultural purposes.
61. Shrubs or ornamental plantings must not be permitted within 10 ft of the pipeline. Plantings within the ROW and greater than 10 ft from the pipeline must be maintained at 5 ft in height or less.
62. Shrubs maturing at more than five feet tall and all trees (including fruit/nut bearing and Christmas tree farms) shall not be permitted within the right-of-way.
63. TC Energy shall not be responsible for replacement of or reimbursement for any plantings within the right-of-way, unless otherwise stated in applicable land rights document.



64. Fence(s) shall cross as near to ninety (90) degrees as possible, but no less than forty-five (45) degrees.
65. Fence or hedge height may not exceed five (5) feet in height. Commercial chain link fences used for security protection or other business requirements may exceed five (5) feet.
66. Fence posts, or similar posts, shall not be placed within five (5) feet of the outermost edge of the pipeline.
67. Electric fence(s) shall be equipped with insulated handled gate or some type of disconnect, that is available to TC Energy.
68. Conductors for electric fences shall not be placed within fifteen (15) feet of any TC Energy above grade piping with mechanical fittings.
69. Fence(s), must be designed and installed to allow at least a sixteen (16) foot gate or opening centered on the pipeline. Gates should be centered on the pipeline unless property lines or similar limitations are present.
70. Permittee shall provide TC Energy access through all gates permitted within the TC Energy right-of-way. If Permittee installs locks on said gates, TC Energy shall also be allowed to install its own locks in a manner that allows TC Energy unimpeded access without limiting Permittee's access.
71. Masonry, brick, or stone walls shall not be permitted on the right-of-way.
72. Permittee will allow TC Energy to place pipeline markers at or near, fences, walls or shrubs in order to identify the pipeline route.

**Section 5: Requirements for Utility Crossings**

73. Concrete pipe is not permitted to cross above the TC Energy pipeline.
74. Water valves, curb boxes, manholes, sprinkler heads, splice boxes, service risers, energized equipment, poles, towers, guy wires, mechanical supports, ground rods, anchors and similar structures are not permitted inside the TC Energy ROW.
75. Warning tape shall be placed over the utility whenever a utility is being installed or replaced. A minimum six (6) inch wide tape that follows A.P.W.A. Uniform Color Code shall be placed directly above the buried utility, where possible. The tape will be buried at least one (1) foot below the surface of the ground. A second warning tape shall be placed at least one (1) foot directly above the utility.
76. The utility shall cross the TC Energy right-of-way as near to ninety (90) degrees as possible, but no less than forty-five (45) degrees.





77. Utilities shall not be installed longitudinally within the right-of-way.
78. The utility shall maintain the same depth of cover across the entire width of the TC Energy ROW if crossing above the TC Energy pipeline.
79. The utility shall maintain elevation across the entire width of the TC Energy ROW if crossing below the TC Energy pipeline.
80. Gravity drainage systems are permitted to have reasonable slope within the ROW if the drain maintains two (2) feet of clearance projected across the ROW.
81. The utility shall not change direction within the TC Energy ROW.
82. Underground utility crossings shall be marked with proper signage at the edge of the TC Energy right-of-way boundaries. Signage shall be according to the A.P.W.A. Uniform Color Code and comply with the authorities having jurisdiction at the edge of each ROW boundary. Exceptions may include agricultural land or open waters.
83. Utilities crossings below the TC Energy pipeline with greater than three (3) feet of clearance may not require additional encasement. TC Energy will review the proposed installation and make the final determination.

**Section 5a: Requirements for non-metallic utilities including water, drains, sewer, and industrial gases installed by open cut excavation.**

84. Utilities shall cross the pipeline with a minimum vertical clearance of two (2) feet for open cut.
85. Non-metallic utilities shall be installed with tracer wire for the full width of the TC Energy right-of-way.
86. At locations where tracer wire is installed, tracer wire shall be raised to the ground surface and connected to a test station for monitoring.
87. Natural gas (or other industrial gases) line crossing below the pipeline shall either be encased in a six (6)-inch envelope of yellow 2,000 psi concrete or encased in four (4)-inch minimum diameter, standard wall thickness, coated steel pipe or four (4) inch minimum diameter Schedule 40 PVC (or equivalent) pipe across the full width of the TC Energy right-of-way.
88. Natural gas (or other industrial gases) line permitted by TC Energy to cross above the pipeline shall be encased in four (4) inch minimum diameter, standard wall thickness, coated steel pipe or four (4) inch minimum diameter Schedule 40 PVC (or equivalent) pipe



across the full width of the TC Energy right-of-way. Do not use concrete for crossings above the pipeline.

**Section 5b: Requirements for metallic utilities including water, drains, sewer, and industrial gases installed by open cut excavation.**

89. Metallic utilities shall be coated with a non-conductive coating for the entire width of the TC Energy right-of-way.
90. Metallic utilities shall cross the pipeline with a minimum vertical clearance of two (2) feet for open cut.
91. Corrosion protection (CP) materials including but not limited to bonds, test leads, test stations, magnesium anode current drains, and permanent reference electrodes shall be installed at the expense of the Permittee. Corrosion materials will be determined by TC Energy upon review of the installation or at the time of construction.  
CP material requirements may include:
  - i. Installation of test leads on both the TC Energy pipeline and the Permittee's crossing structure.
  - ii. Installation of a permanent Copper-Copper Sulfate ( $\text{CuCuSO}_4$ ) reference electrode between the TC Energy pipeline and the Permittee's crossing structure.
92. Permittee shall be responsible for the corrosion protection of its facilities against TC Energy's cathodic protection system. Permittee shall be responsible for installation of facilities on its structures. TC Energy shall provide personnel, at the expense of Permittee, for installation of facilities on TC Energy's pipelines.
93. The permittee will be responsible to work with TC Energy to perform cooperative interference testing of the existing and newly installed corrosion protection systems. Any interference found will be mitigated by the permittee.

**Section 5c: Requirements for electric, fiber optic/cable installed by open cut excavation.**

94. All underground electric under 600V and fiber optic utilities permitted by TC Energy shall cross the pipeline with a minimum vertical clearance of two (2) feet.
95. All underground electric above 600V permitted by TC Energy shall cross the pipeline with a minimum vertical clearance of three (3) feet.
96. The design of buried electrical cables energized to 600 volts or more installed within 900 feet of TC Energy's pipeline(s) must be reviewed and approved by TC Energy. This review may require installation of induced AC mitigation facilities.





97. All underground electric and fiber optic utilities permitted by TC Energy to cross below the pipeline shall be encased with a minimum of two (2) inch Schedule 40 PVC pipe, or equivalent, for the complete width of the right-of-way **and** also be surrounded with a minimum of six (6) inches of colored concrete in accordance with the A.P.W.A. Uniform Color Code or four (4) inch minimum diameter, standard inch wall thickness, coated steel or Schedule 40 PVC pipe across the full width of the TC Energy right-of- way.
- i. Underground electric and fiber optic utilities permitted by TC Energy to cross in excess of three (3) feet below the pipeline do not require the use of concrete or an additional conduit.
98. All underground electric and fiber optic utilities permitted by TC Energy to cross above the pipeline shall be encased in two (2) inch minimum diameter Schedule 40 PVC pipe for the complete width of the right-of-way **and** a four (4) inch minimum diameter, standard inch wall thickness, coated steel pipe or Schedule 40 PVC pipe across the full width of the TC Energy right-of-way.
99. Spare conduits that can be identified for future use may be installed. Spare conduits must be installed at the same depth as the main conduit.
100. Conduits must be installed and marked to meet all requirements of the specific type of approved Crossing (e.g., tracer wire, warning tape).

**Section 5c: Requirements for electric, fiber optic/cable installed aboveground.**

101. Aboveground cables shall be installed with a minimum of thirty-three (33) feet above grade clearance for the full width of the TC Energy right-of-way.
102. The design of overhead electrical cables energized to 600 volts or more installed within 900 feet of TC Energy's pipeline(s) must be reviewed and approved by TC Energy. This review may require installation of induced AC mitigation facilities, and additional aerial markers.
103. Unacceptable levels of AC or DC stray current caused by the installation of a foreign utility crossing will be mitigated at the expense of the Permittee.

**Section 5d: Requirements for utilities installed by trenchless excavation.**

104. All utilities installed via trenchless excavation require three (3) feet of clearance from the TC Energy pipeline.
105. Underground utilities permitted by TC Energy to cross in excess of three (3) feet below the pipeline do not require the use of concrete or an additional conduit.



106. Natural gas (or other industrial gases) line permitted by TC Energy to cross above the pipeline shall be encased in four (4) inch minimum diameter, standard wall thickness, coated steel pipe or four (4) inch minimum diameter Schedule 40 PVC (or equivalent) pipe across the full width of the TC Energy right-of-way. Do not use concrete for crossings above the pipeline.
107. All underground electric and fiber optic utilities permitted by TC Energy to cross above the pipeline shall be encased in two (2) inch minimum diameter Schedule 40 PVC pipe for the complete width of the right-of-way **and** a four (4) inch minimum diameter, standard inch wall thickness, coated steel pipe or Schedule 40 PVC pipe across the full width of the TC Energy right-of-way.
108. Spare conduits that can be identified for future use may be installed. Spare conduits must be installed at the same depth as the main conduit.
109. Conduits must be installed and marked to meet all requirements of the specific type of approved Crossing (e.g., tracer wire, warning tape).
110. Trenchless excavation requires prior approval with drawings which detail the excavation plan.
111. During trenchless excavation:
  - i. A sight inspection hole must be excavated as follows to prevent the drill bit from coming in contact with the pipeline:
    - i. Minimum of 5 ft and a maximum of 10 ft from the side (nearest to the drill) of each buried pipeline
    - ii. Depth at least 36 in. below the bottom of the pipeline
    - iii. Sight inspection holes parallel to the pipeline, a minimum of 10 ft long, and sufficiently wide to provide visual confirmation of the borehead
    - iv. Where the sight inspection hole is not practical, additional requirements may apply, including but not limited to additional vertical clearance
  - ii. Centerline of the bore must be marked for trenchless excavation.
  - iii. Spoil piles must not be placed over the bore path as this increases the depth of cover.
  - iv. Any bore pits required to setup and stage equipment must be located outside of the ROW.
  - v. Tracking equipment is required to track the location of the drill head and must be:
    - i. Verified for operability within tolerances
    - ii. Field tested on site to confirm operation (the test should be documented by the permittee and approved on-site by the Operations representative)
  - vi. Continuously monitor the progress of the drill head and ensure it can be visually seen entering the sight inspection holes at the expected depth and location.
  - vii. If the drill head does not enter the sight inspection hole at the expected depth and location, stop the drill and reassess the bore. Confirm that there are no hazards prior to re-commencing the bore. This may require:





- i. Adjusting the drill head
- ii. Reconfirming the expected centerline of the drill head entry at sight inspection holes
- iii. Enlarging or lengthening sight inspection holes
- iv. Pulling back and restarting the bore where required

**Section 6: Requirements for field tile installation.**

112. Permittee shall execute the Field Tile Agreement, prior to any field tile installations that occur from the edge of TC Energy right of way to the edge of TC Energy right of way. Permitted field tile or drainage pipe shall cross the pipeline right-of-way at or as near to ninety (90) degrees as possible, but no less than forty-five (45) degrees. A minimum clearance of twelve (12) inches above or below the pipeline shall be maintained. Field tile shall not drain onto a TC Energy right-of-way. Longitudinal runs of field tile shall not be within fifteen (15) feet of TC Energy pipelines.

**Section 7: Requirements for Dredging.**

113. Dredging activities within 500 feet of the TC Energy right-of-way shall comply with the following minimum requirements:

- i. A TC Energy representative must meet with the Corps of Engineers representative to review the plan.
- ii. TC Energy must be contacted at least 72 hours prior to coming within 500 feet of the pipeline.
- iii. When practical an Operations Representative should be on board the barge when the dredging operation is within 500 ft of the nearest pipeline.

**Section 8: Requirements for Blasting.**

114. A blasting plan must be submitted to the Company 10 business days (excludes Saturday, Sunday, or federal holiday) in advance of any blasting proposed within 325 ft of a Company pipeline.

115. The Company must perform a blasting analysis to determine blasting requirements.

116. Blasting must not commence without prior review and approval from the Company.

117. Any modifications to the blasting plan must be submitted to the Company for prior review and approval.

118. The Third-Party must conduct and submit to the Company a three-axis seismic survey for each blast event within 325 ft of a Company pipeline, unless otherwise permitted by the Company.



119. Seismic monitoring equipment must be placed over the pipeline at the nearest point to the blast activities when the blast is within 325 ft of a Company pipeline. One axis must be aligned parallel to the pipeline and another axis perpendicular to the pipeline.
120. Storage of explosive and other equipment on the ROW is strictly prohibited. Explosives must not be stored within 1,000 ft of the ROW.

### Attachment “B.” TC Energy Heavy Equipment Crossing Information Form

		TC ENERGY OPERATING PROCEDURE (FORM)	
Title: Heavy Equipment Crossing Information Form			
Revision: 09	Publish Date: 2021/09/01	Status Published:	Driver: Best Practice
			Page 145 of 3

**TOP Contact:** Christine Balash



**Instructions:**

1. This form is to be completed in conjunction with [Pipeline Crossing and Encroachment Procedure](#) (US) (Item ID: 003858625) and [Pipeline Crossing and Encroachment Procedure \(Canada\)](#) (Item ID: 003674617).
2. Operations to complete form and send to Land Services or IES Engineer in US or TC Energy Land Department in Canada.
3. Save this form as follows (Steps 2 is only required if you are filing the form electronically).
  - For Canada – For 1<sup>st</sup> and 2<sup>nd</sup> party crossing requests, please submit completed form to Integrity\_Crossings@TCEnergy.com
  - For US - For minor crossings (Land Services not involved), Operation to file in local office. For major crossings (Land Services is involved), Land Services to file in the Land Tract File database.
4. Information on filing and the onsite/offsite retention requirements, please refer to the '[Facility Filing Structure Reference](#)' compliance list (Item ID: 003794696).

Crossing Information (To be completed by Operations or on-site technician)	
<b>Requesting Company /Stakeholder:</b>	Ph.: (     )
<b>TC Energy Contact:</b>	Ph.: (     )
<b>Stakeholder Type:</b> <input type="checkbox"/> Landowner, <input type="checkbox"/> Contractor, <input type="checkbox"/> Utility, <input type="checkbox"/> Developer, <input type="checkbox"/> Other (describe)	
<b>Notified How?</b> <input type="checkbox"/> One Call, <input type="checkbox"/> Contacted by Landowner, <input type="checkbox"/> Aerial Patrol, <input type="checkbox"/> Other (describe)	
<b>Legal Location / Milepost / MLV:</b>	
<b>GPS Location (decimal degrees to 7 decimals)</b>	
<b>Units of Measurement:</b> <input type="checkbox"/> Imperial (e.g. lbs / ft), <input type="checkbox"/> Metric (e.g. kg / m),	
<b>TC Energy PL Drawing #</b> (if applicable):	
<input type="checkbox"/> <b>Permanent Crossing - Date Required:</b>	
<input type="checkbox"/> <b>Temporary Crossing - Approx. Date / Duration:</b>	

Equipment Information (encroaching party to complete the following table for each piece of heavy equipment)				
Equipment Information	Equipment #1	Equipment #2	Equipment #3	Equipment #4
Type or Model of Equipment				
Total Weight – Fully Loaded ( <input type="checkbox"/> lbs <input type="checkbox"/> kg)				
<b>Track</b>	Width of Track Shoe ( <input type="checkbox"/> ft <input type="checkbox"/> m)			
	Length of Track on Ground ( <input type="checkbox"/> ft <input type="checkbox"/> m)			
	Distance Between Tracks ( <input type="checkbox"/> ft <input type="checkbox"/> m)			
Number of Wheels (include front)				

<b>Wheel</b>	<b>Number of Axles (include front) axle</b>				
	<b>Weight on heaviest axle (<input type="checkbox"/> lbs <input type="checkbox"/> kg)</b>				

		<b>TC ENERGY OPERATING PROCEDURE (FORM)</b>			
<b>Title: Heavy Equipment Crossing Information Form</b>					
Revision: 09	Publish Date: 2021/09/01	Status Published:	Driver: Best Practice	Page 2 of 3	

<b>Soils Information</b> (To be completed by Operations or on-site technician, consult engineering if unsure of category)	
<b>Soil Type (Select one)</b>	<input type="checkbox"/> Granular Materials without cohesion (dry sand) / <input type="checkbox"/> Sand and Gravel / <input type="checkbox"/> Saturated Topsoil / <input type="checkbox"/> Clay / <input type="checkbox"/> Saturated Clay / <input type="checkbox"/> Other (describe):
<b>Soil Saturation Level (Select One)</b>	<input type="checkbox"/> Wet / <input type="checkbox"/> Dry / <input type="checkbox"/> Normally Dry / <input type="checkbox"/> Normally Wet / <input type="checkbox"/> Transitional Area Dry to Wet / <input type="checkbox"/> Other (describe):
<b>Crossing Type (Select One)</b>	<input type="checkbox"/> Asphalt / <input type="checkbox"/> Concrete / <input type="checkbox"/> Timber Mats / <input type="checkbox"/> No pavement / <input type="checkbox"/> Other (describe):
<b>Construction Type if known (Select One)</b>	<input type="checkbox"/> Open Cut / <input type="checkbox"/> Bored Crossing / <input type="checkbox"/> Open cut-rock / <input type="checkbox"/> Other (describe):

Pipeline Information (To be completed by Operations or on-site technician)				
Pipeline Name				
Pipeline Route Number				
Pipeline OD				
Pipeline Wall Thickness ( <input type="checkbox"/> in <input type="checkbox"/> mm)				
Pipeline SMYS or Grade ( <input type="checkbox"/> psi <input type="checkbox"/> kPa)				
Class Location				
MAOP of Pipeline Segment ( <input type="checkbox"/> psi <input type="checkbox"/> kPa)				
Coupled, Welded or Threaded pipe joints	<input type="checkbox"/> C <input type="checkbox"/> W <input type="checkbox"/> T	<input type="checkbox"/> C <input type="checkbox"/> W <input type="checkbox"/> T	<input type="checkbox"/> C <input type="checkbox"/> W <input type="checkbox"/> T	<input type="checkbox"/> C <input type="checkbox"/> W <input type="checkbox"/> T
Existing Depth of Cover ( <input type="checkbox"/> in <input type="checkbox"/> m)				
Crossing Evaluation (To be completed by Engineering)				
Evaluation Results % SMYS (US only)				
Results (Pass or Fail) (US only)	<input type="checkbox"/> pass <input type="checkbox"/> fail	<input type="checkbox"/> pass <input type="checkbox"/> fail	<input type="checkbox"/> pass <input type="checkbox"/> fail	<input type="checkbox"/> pass <input type="checkbox"/> fail
Crossing Requirements (none, wood mats, steel plates, air gap, other) (US only)	<input type="checkbox"/> none <input type="checkbox"/> wm <input type="checkbox"/> sp <input type="checkbox"/> ag <input type="checkbox"/> o	<input type="checkbox"/> none <input type="checkbox"/> wm <input type="checkbox"/> sp <input type="checkbox"/> ag <input type="checkbox"/> o	<input type="checkbox"/> none <input type="checkbox"/> wm <input type="checkbox"/> sp <input type="checkbox"/> ag <input type="checkbox"/> o	<input type="checkbox"/> none <input type="checkbox"/> wm <input type="checkbox"/> sp <input type="checkbox"/> ag <input type="checkbox"/> o
Evaluated By:				Date:
Additional Crossing Requirements:				
<b>Note:</b> If more than four pipelines are being crossed with different attributes please complete this section for the additional lines and attach multiple copies to heavy equipment form.				
<b>Please include an explanation, diagram or photos of the crossing equipment using the space provided:</b>				

	TC ENERGY OPERATING PROCEDURE (FORM)	
Title: Heavy Equipment Crossing Information Form		
Revision: 09	Publish Date: 2021/09/01	Status Published: Driver: Best Practice <span style="float: right;">Page 3 of 3</span>

FAI Route 80 (I-80)  
Project NHHP-HISX(002)  
Section FAI 80 21 STRUCTURE 5  
Will County  
Contract No. 62R26



**Attachment "C." TC Energy  
 TEF-IN-CROSS-GL Application to Work on or Within 100 ft of TC Energy ROW (US)**

TC Energy Engineering Form

**TEF-IN-CROSS-GL Application to Work on or  
 Within 100 ft of TC Energy ROW (US)**



Item ID: 1013361828      Rev.: 01      Driver: Regulatory      Status: Published      Publish Date: 2021-May-03

**Instructions for TC Energy Personnel**

1. Provide this form to the Third Party as per [Pipeline Crossing and Encroachment Procedure \(US\)](#) (Item ID: 003858625).
2. Maintain electronic signed form in the Tract file database.
3. If there is an on-site requirement for the hard copy documentation, please refer to the compliance list in [TransCanada Facility Filing Structure Reference](#) (Item ID: 003794696) for information on filing this form.

**Application Request**

Date (yyyy-mm-dd):	Time (am/pm):	Received by:	
Legal Location:	GPS Coordinates:	Latitude:	Longitude:
Applicants Name:	Representing:		
Mailing Address:			
Phone Number:	Mobile:	Email:	
TC Energy Representative:			

**Description of Work**

Describe in detail the scope of work to be undertaken in the vicinity of TC Energy facilities:	
Date work is taking place (yyyy-mmm-dd):	
Location of work taking place (e.g., legal description, address, GPS coordinates.)	
Will you have to cross TC Energy facilities to conduct work? <input type="checkbox"/> Yes <input type="checkbox"/> No	If yes, request a <a href="#">Heavy Equipment Crossing Information Form</a> (Item ID: 003677225) from TC Energy.
Will this work involve explosive blasting? <input type="checkbox"/> Yes <input type="checkbox"/> No	If yes, request an <a href="#">Explosive Blasting Form</a> (Item ID: 005461313) from TC Energy.
Please complete a sketch describing the proposed crossing, excavation, or construction. Show the positions of aboveground features which can assist us in determining where the work will occur (e.g., fences, roads, buildings, creeks, drains, trees).	
Applicant Signature:	Date (yyyy-mm-dd):
TC Energy Representative Signature:	

## **FILLING EXISTING RUMBLE STRIP**

**Description.** This work shall consist of the scarification of existing shoulder rumble strips constructed in hot-mix asphalt shoulders, and the furnishing and placement of hot-mix asphalt in the scarified area, prior to placing traffic onto the shoulder in a construction stage. This work shall take place per the limits shown on the Plans and/or directed by the Engineer.

**General Requirements.** The nominal depth of scarification of the hot-mix asphalt shoulders shall be 2- inches. Unless otherwise shown in the Plans, the width of the scarification shall be four (4) feet, measured from the mainline pavement longitudinal joint between the mainline pavement and adjoining shoulder.

After removing all millings from the scarified limits, the surface shall be tacked in accordance with Article 406.05(b) of the Standard Specifications.

The scarified area shall then be filled with hot-mix asphalt surface course and compacted flush with the adjoining pavement and shoulder surfaces. The mix to be used for this item shall be Hot Mix Asphalt Surface Course, IL9.5, Mix D, N70 unless otherwise specified in the Contract.

**Method of Measurement.** FILLING EXISTING RUMBLE STRIP will be measured for payment in feet. Any portion of this work constructed outside the dimensions shown on the Plans or as directed by the Engineer will not be measured for payment.

**Basis of Payment.** Payment for FILLING EXISTING RUMBLE STRIP, measured as specified will be made at the Contract unit price per foot, which payment shall constitute full compensation for scarifying the designated portion of hot-mix asphalt shoulder; cleaning the scarified area and removing all debris; applying tack; furnishing, placing and compacting hot-mix asphalt surface mix; and for all labor, equipment, tools and incidentals necessary to complete the work as specified.

Shoulder closures required for this item will not be paid for separately, but will be included in the Contract unit price TRAFFIC CONTROL AND PROTECTION (EXPRESSWAYS).

## **MAINTAINING ITS DURING CONSTRUCTION**

**Description.** Intelligent Transportation Systems (ITS) references IDOT traffic surveillance infrastructure. These elements include, but are not limited to, the following: induction loops, ramp meters, closed circuit television cameras, dynamic message signs, highway advisory radios, Radar Vehicle Sensing Devices (RVSDs), wireless vehicle detection devices, copper and fiber optic communication cables, power cables, cabinets, and communication equipment.

**General Requirements.** Effective the date the Contractor's activities (ITS or otherwise) begin at the job site, the Contractor shall be responsible for the proper operation and maintenance of ITS elements that are part of, or that may be affected by, the work until final acceptance by the Engineer or as otherwise determined by the Engineer.

Before performing any excavation, removal, or installation work (ITS or otherwise) at the site, the Contractor shall initiate a request for a maintenance transfer and preconstruction inspection to be held in the presence of the Engineer and a representative of the party or parties responsible for maintenance of any ITS systems that may be affected by the work. This includes co-ordination with adjacent projects that may have an effect on the ITS infrastructure. The request for the maintenance preconstruction inspection shall be made no less than seven (7) calendar days prior to the desired inspection date.

Existing ITS elements, when depicted on the plans, are intended only to indicate the general equipment installation of the systems involved and shall not be construed as an exact representation of the field conditions. It remains the Contractor's responsibility to visit the site to confirm and ascertain the exact condition and location of the ITS components and systems to be maintained and installed.

Existing ITS components shall be defined as any ITS component or device in service at the time of the commencement of construction activities. The contract drawings indicate the general extent of any existing ITS elements, but whether indicated or not, it remains the Contractor's responsibility to ascertain the extent of effort required for compliance with these specifications, and failure to do so will not be justification for extra payment or reduced responsibilities.

Maintaining ITS During Construction - It is the Contractor's responsibility to maintain vehicle detection, which includes speed and volume data, in all lanes within the construction limits for this project, on all roadway segments and ramps that will be open to traffic. Where the existing detection cannot be maintained, the Contractor shall provide a temporary detection system, approved by IDOT, at no additional cost to the contract. The Contractor's responsibility shall include protection or removal and storage of any ITS/Communication cabinets and protecting in place any cables, conduits and ITS devices in or adjacent to the work zone. This work may also include the abandonment of the existing device and communication pathway and the installation of a temporary device such as a RVSD with a wireless communication. This work shall also include the relocation and adjustment of RVSD and wireless detection devices as necessary in coordination with construction staging. It is the Contractor's responsibility to maintain closed circuit television cameras including associated fiber optic communications and power.

The Contractor is responsible for the disconnection, rerouting, and reconnection of all fiber and copper communication cables currently located in existing conduits as indicated in the plans. The disconnection and reconnection must be made at an existing splice point or communication cabinet where a connection is made, or as otherwise indicated in the plans. The existing communication and infrastructure must be properly maintained for the duration of construction activities and the Contractor must coordinate the disconnection and reconnection activities with the Engineer.

All work required to maintain, relocate or provide temporary ITS infrastructure as depicted in the plans or otherwise necessary and as provided for in this special provision shall be paid for under the Maintaining ITS During Construction pay item. No component items germane to this work shall be paid for separately.

Once construction activities are complete, all temporary equipment installed will become the property of the Department and shall remain in place, except where a proposed location has been identified in the plans. All final locations and installations of ITS devices, communication cabinets, junction boxes, conduit, fiber optic, copper cable, wireless equipment and associated infrastructure shall be protected, secured and have the Engineer's approval. Proper documentation, to include latitude and longitude for all equipment locations and communication pathway must be turned over to the Department. The proposed plan for this work must be presented to the Engineer for approval prior to the commencement of the work.

**Method of Measurement.** The contractor shall demonstrate to the satisfaction of the Engineer that the ITS components, devices and infrastructure have been properly installed, protected and maintained and that the appropriate data is being transmitted to the Traffic Management Center prior to submitting a pay request. In order for final payment to be released the contractor must demonstrate that the equipment is working as intended following inspection by the Engineer. Failure to do so will be grounds for denying the pay request.

**Basis of Payment.** Maintaining ITS During Construction and Rerouting ITS Communication shall be paid for at the contract unit price per calendar month (Cal Mo) for MAINTAINING ITS DURING CONSTRUCTION, which shall include all work as described herein.

## **MOWING (SPECIAL)**

Modified: December 7, 2017

Description: This work shall consist of mowing and or hand trimming areas of large stands of aggressive herbaceous vegetation to a height of 6". It shall take place in very difficult to mow areas that may consist of one or more of the following scenarios: narrow spaces less than 2 feet wide, steep slopes greater than 2:1, excessive debris and brush, areas of permanently wet conditions, and/or areas of uneven ground. These areas may not be able to be mowed with typical roadside mowing equipment.

Schedule and Height of Mowing: As directed by the Engineer.

Equipment: The Contractor shall keep all mowing equipment sharp and properly equipped for operation within an urban arterial route. The equipment used shall be capable of completely severing all growth at the cutting height and distributing it evenly over the mowed area. Special equipment may be required to cut weed trees and brush up to 2" diameter on steep slopes, in narrow areas, and for trimming around posts, poles, trees, shrubs, seedlings, along fences and concrete retaining walls, etc.

Method: All mowing and trimming operations are to proceed in the direction of traffic flow. The cut material shall not be windrowed or left in a lumpy or bunched condition. All drain inlets must be kept clean and draining freely. Additional mowing or trimming may be required to obtain the height specified or to disperse mowed material. When amount of grass is heavy, cut grass shall be removed to prevent destruction of underlying turf. If weeds or other undesirable vegetation threatens to smother planted species, or in case of weeds exceeding growth of planted species, at the direction of the Engineer, the weeds shall be uprooted, raked and removed from the area. No more than 1/3 of the total growth of grass shall be cut off at one time and only when plants are dry and soil is not wet.

Remove litter, including plastic bags, paper, bottles, etc. prior to mowing. Debris encountered during the mowing operations, including the cut material from *Phragmites* species and *Teasel* species, shall be removed and disposed of according to Article 202.03. All trimmings, windrowed material, litter and debris removal must be complete to the satisfaction of the Engineer. Damage to the turf, such as ruts or wheel tracks more than 2 inches (50 MM) in depth, scalping of the mowed areas, or other plantings or highway appurtenances caused by the mowing or trimming operation shall be repaired at the Contractor's expense and to the satisfaction of the Engineer.

Method of Measurement: Mowing and trimming will be measured in acres of surface area mowed.

Basis of Payment: This work will be paid for at the contract unit price per acre for MOWING (SPECIAL). Any additional mowing or trimming required to obtain the height specified or to disperse mowed material will be considered as included in the cost of the initial mowing. Payment for mowing and trimming shall include the cost of all material, equipment, labor, removal, disposal and incidentals required to complete the work as specified herein and to the satisfaction of the Engineer.

## **MOWING CYCLES**

Modified: May 25, 2023

Effective: June 1, 2023

### Description

This work shall consist of mowing turf areas along the expressway (**approximately 11.5 ACRES**) to a height of 6 inches and as directed by the Engineer, within all IDOT ROW will be mowed starting April 1, or any time after the grass starts growing.

The work required for each work cycle must be 100 percent complete on inspection dates. Partial inspections will not be made.

### Frequency

The project site will be mowed once a month throughout construction within the construction limits after establishment to keep flowering weeds from reseeding & establishing, thereby aiding in early prairie grass establishment in the project area. The work shall continue until the last week in October or until directed the Engineer

### Equipment

The Contractor shall keep the blades of all mowing equipment sharp and properly equipped for operation along an urban arterial route. The equipment used shall be capable of completely severing all growth at the cutting height and distributing it evenly over the mowed area. Special equipment may be required on steep slopes, in narrow areas, and for trimming around posts, poles, fences, trees, shrubs, seedlings, etc.

### Method

All mowing and trimming operations are to proceed in the direction of traffic flow. The cut material shall not be windrowed or left in a lumpy or bunched condition. Additional mowing or trimming may be required to obtain the height specified or to disperse mowed material.

Debris encountered during the mowing operations which hampers the operation or is visible from the roadway shall be removed prior to mowing and disposed of according to Article 202.03. Remove all grass clippings from paved surfaces (Knee wall surfaces, high mast light tower pads, paved gutters and paved gore areas.) All trimmings, windrowed material, litter and trash removal must be complete to the satisfaction of the Engineer. Damage to the turf, such as ruts or wheel tracks more than 2 inches (50 MM) in depth, or other plantings or highway appurtenances caused by the mowing or trimming operation shall be repaired at the Contractor's expense.

### Method of Measurement

Mowing and trimming will be measured as each at the completion of each mowing cycle. The approximate quantity of acres shall be entirely mowed during this cycle.

### Basis of Payment

This work will be paid for at the contract unit price per each for MOWING CYCLES. Any additional mowing or trimming required to obtain the height specified or to disperse mowed material will be considered as included in the cost of the initial mowing. Payment for mowing and trimming shall include the cost of all material, equipment, labor, removal, disposal and incidentals required to complete the work as specified herein and to the satisfaction of the Engineer.

## PROTECTION OF EXISTING TREES

The Contractor shall be responsible for taking measures to minimize damage to the tree limbs, tree trunks, and tree roots at each work site. All such measures shall be included in the contract price for other work except that payment will be made for TEMPORARY FENCE and TREE ROOT PRUNING.

All work, materials and equipment shall conform to Section 201 and 1081 of the Standard Specifications except as modified herein.

### A. Earth Saw Cut of Tree Roots (Root Pruning):

1. Whenever proposed excavation falls within a drip-line of a tree, the Contractor shall:
  - a. Root prune 6-inches behind and parallel to the proposed edge of trench a neat, clean vertical cut to a minimum depth directed by the Engineer through all affected tree roots.
  - b. Root prune to a maximum width of 4-inches using a "Vermeer" wheel, or other similar machine. Trenching machines will not be permitted.
  - c. Exercise care not to cut any existing utilities.
  - d. If during construction it becomes necessary to expose tree roots which have not been pre-cut, the Engineer shall be notified and the Contractor shall provide a clean, vertical cut at the proper root location, nearer the tree trunk, as necessary, by means of hand-digging and trimming with chain saw or hand saw. Ripping, shredding, shearing, chopping or tearing will not be permitted.
  - e. Top Pruning: When thirty percent (30%) or more of the root zone is pruned, an equivalent amount of the top vegetative growth or the plant material shall be pruned off within one (1) week following root pruning.
2. Whenever curb and gutter is removed for replacement, or excavation for removal of or construction of a structure is within the drip line/root zone of a tree, the Contractor shall:
  - a. Root prune 6-inches behind the curbing so as to neatly cut the tree roots.
  - b. Depth of cut shall be 12 inches for curb removal and replacement and 24 inches for structural work. Any roots encountered at a greater depth shall be neatly saw cut at no additional cost.
  - c. Locations where earth saw cutting of tree roots is required will be marked in the field by the Engineer.
3. All root pruning work is to be performed through the services of a licensed arborist to be approved by the Engineer.

Root pruning will be paid for at the contract unit price each for TREE ROOT PRUNING, which price shall be payment for all labor, materials and equipment.

B. Temporary Fence:

1. The Contractor shall erect a temporary fence around all trees within the construction area to establish a "tree protection zone" before any work begins or any material is delivered to the jobsite. No work is to be performed (other than root pruning), materials stored or vehicles driven or parked within the "tree protection zone".
2. The exact location and establishment of the "tree protection zone" fence shall be approved by the Engineer prior to setting the fence.
3. The fence shall be erected on three sides of the tree at the drip-line of the tree or as determined by the Engineer.
4. All work within the "tree protection zone" shall have the Engineer's prior approval. All slopes and other areas not regarded should be avoided so that unnecessary damage is not done to the existing turf, tree root system ground cover.
5. The grade within the "tree protection zone" shall not be changed unless approved by the Engineer prior to making said changes or performing the work.

The fence shall be similar to wood lath snow fence (48 inches high), plastic poly-type or and other type of highly visible barrier approved by the Engineer. This fence shall be properly maintained and shall remain up until final restoration, unless the Engineer directs removal otherwise. Temporary fence shall be supported using T-Post style fence posts. **Utilizing re-bar as a fence post will not be permitted.**

Temporary fence will be paid for at the contract unit price per foot for TEMPORARY FENCE, which price shall include furnishing, installing, maintaining, and removing.

C. Backfilling:

1. Prior to placing the topsoil and/or sod, in areas outside the protection zone, the existing ground shall be disked to a depth no greater than one (1"), unless otherwise directed by the Engineer. No grading will be allowed within the dripline of any tree unless directed by the Engineer.



## **PRUNING FOR SAFETY AND EQUIPMENT CLEARANCE**

This Special Provision revises Section 201 of the Standard Specifications to provide payment of pruning for safety and equipment clearance.

Delete Article 201.10(c)(3) and substitute the following:

Pruning for Safety and Equipment Clearance will be measured for payment on a lump sum basis.

Delete the third paragraph of Article 201.11(c) and replace with the following:

Pruning for Safety and Equipment Clearance will be paid for at the contract lump sum price for PRUNING FOR SAFETY AND EQUIPMENT CLEARANCE.

## **REMOVAL AND DISPOSAL OF REGULATED SUBSTANCES (PROJECT SPECIFIC)**

**Description.** This work shall consist of the removal and disposal of regulated substances according to Section 669 of the Standard Specifications as revised below.

**Contract Specific Sites.** The excavated soil and groundwater within the areas listed below shall be managed as either “uncontaminated soil”, hazardous waste, special waste or non-special waste. For stationing, the lateral distance is measured from centerline and the farthest distance is the offset distance or construction limit, whichever is less.

**Soil Disposal Analysis.** When the waste material requires sampling for landfill disposal acceptance, the Contractor shall secure a written list of the specific analytical parameters and analytical methods required by the landfill. The Contractor shall collect and analyze the required number of samples for the parameters required by the landfill using the appropriate analytical procedures. A copy of the required parameters and analytical methods (from landfill email or on landfill letterhead) shall be provided as Attachment 4A of the BDE 2733 (Regulated Substances Final Construction Report). The price shall include all sampling materials and effort necessary for collection and management of the samples, including transportation of samples from the job site to the laboratory. The Contractor shall be responsible for determining the specific disposal facilities to be utilized; and collect and analyze any samples required for disposal facility acceptance using a NELAP certified analytical laboratory registered with the State of Illinois.

Site 2233V3-1: ROW Approximate I-80 M.M. 121.5 to M.M. 138, Minooka, Shorewood, Channahon, Joliet, Rockdale, New Lenox, and unincorporated Seward, Troy, Joliet, and New Lenox Townships, Will County

#### Ramp A

- Station 100+00 to Station 104+45 (CL Ramp A), from 50 feet LT to 25 feet RT. The Engineer has determined this material meets the criteria of and shall be managed in accordance with Article 669.05(a)(2). Contaminants of concern sampling parameter: Manganese.
- Station 104+45 to Station 106+10 (CL Ramp A), from 50 feet LT to 40 feet RT. The Engineer has determined this material meets the criteria of and shall be managed in accordance with Article 669.05(a)(5). Contaminants of concern sampling parameters: Arsenic and Manganese.
- Station 106+10 to Station 107+70 (CL Ramp A), from 55 feet LT to 40 feet RT. The Engineer has determined this material meets the criteria of and shall be managed in accordance with Article 669.05(a)(2). Contaminants of concern sampling parameter: Manganese.
- Station 107+70 to Station 109+30 (CL Ramp A), from 80 feet LT to 50 feet RT. The Engineer has determined this material meets the criteria of and shall be managed in accordance with Article 669.05(a)(1). Contaminants of concern sampling parameter: Manganese.
- Station 111+20 to Station 112+10 (CL Ramp A), from 80 feet LT to 70 feet RT. The Engineer has determined this material meets the criteria of and shall be managed in accordance with Article 669.05(a)(1). Contaminants of concern sampling parameter: Manganese.

#### Ramp AA

- Station 0+00 to Station 1+40 (CL Ramp AA), from 80 feet LT to 70 feet RT. The Engineer has determined this material meets the criteria of and shall be managed in accordance with Article 669.05(a)(1). Contaminants of concern sampling parameters: Iron, and Manganese.
- Station 1+40 to Station 8+00 (CL Ramp AA), from 80 feet LT to 80 feet RT. The Engineer has determined this material meets the criteria of and shall be managed in accordance with Article 669.05(a)(2). Contaminants of concern sampling parameters: Lead, and Manganese.
- Station 8+00 to Station 10+00 (CL Ramp AA), from 0 to 80 feet RT. The Engineer has determined this material meets the criteria of and shall be managed in accordance with Article 669.05(a)(1). Contaminants of concern sampling parameters: Benzo(a)pyrene, and Manganese.
- Station 8+00 to Station 10+00 (CL Ramp AA), from 0 to 70 feet LT. The Engineer has determined this material meets the criteria of and shall be managed in accordance with Article 669.05(a)(2). Contaminants of concern sampling parameter: Manganese.
- Station 10+00 to Station 11+45 (CL Ramp AA), from 100 feet LT to 100 feet RT. The Engineer has determined this material meets the criteria of and shall be managed in accordance with Article 669.05(a)(2). Contaminants of concern sampling parameter: Manganese.
- Station 11+45 to Station 13+20 (CL Ramp AA), from 0 to 100 feet LT. The Engineer has determined this material meets the criteria of and shall be managed in accordance with Article 669.05(a)(1). Contaminants of concern sampling parameters: Benzo(a)pyrene, and Manganese.
- Station 11+45 to Station 13+20 (CL Ramp AA), from 0 to 100 feet RT. The Engineer has determined this material meets the criteria of and shall be managed in accordance with Article 669.05(a)(2). Contaminants of concern sampling parameter: Manganese.

- Station 13+20 to Station 14+90 (CL Ramp AA), from 70 feet LT to 100 feet RT. The Engineer has determined this material meets the criteria of and shall be managed in accordance with Article 669.05(a)(2). Contaminants of concern sampling parameter: Manganese.
- Station 14+90 to Station 18+00 (CL Ramp AA), from 40 feet LT to 50 feet RT. The Engineer has determined this material meets the criteria of and shall be managed in accordance with Article 669.05(a)(1). Contaminants of concern sampling parameters: Benzo(a)pyrene, and Manganese.
- Station 19+80 to Station 23+50 (CL Ramp AA), from 125 feet LT to 125 feet RT. The Engineer has determined this material meets the criteria of and shall be managed in accordance with Article 669.05(a)(2). Contaminants of concern sampling parameters: Lead, and Manganese.
- Station 24+80 to Station 26+20 (CL Ramp AA), from 140 feet LT to 120 feet RT. The Engineer has determined this material meets the criteria of and shall be managed in accordance with Article 669.05(a)(2). Contaminants of concern sampling parameter: Manganese.
- Station 26+20 to Station 27+80 (CL Ramp AA), from 120 feet LT to 60 feet RT. The Engineer has determined this material meets the criteria of and shall be managed in accordance with Article 669.05(a)(1). Contaminants of concern sampling parameter: Manganese.
- Station 27+80 to Station 28+75 (CL Ramp AA), from 70 feet LT to 60 feet RT. The Engineer has determined this material meets the criteria of and shall be managed in accordance with Article 669.05(a)(2). Contaminants of concern sampling parameter: Manganese.

#### Ramp B

- Station 982+95 to Station 991+20 (CL Ramp B), from 0 to 30 feet RT. The Engineer has determined this material meets the criteria of and shall be managed in accordance with Article 669.05(a)(1). Contaminants of concern sampling parameters: Lead, and Manganese.
- Station 993+10 to Station 995+00 (CL Ramp B), from 0 to 50 feet RT. The Engineer has determined this material meets the criteria of and shall be managed in accordance with Article 669.05(a)(2). Contaminants of concern sampling parameter: Manganese.
- Station 995+00 to Station 999+90 (CL Ramp B), from 10 feet LT to 60 feet RT. The Engineer has determined this material meets the criteria of and shall be managed in accordance with Article 669.05(b)(1).
- Station 999+90 to Station 1001+70 (CL Ramp B), from 15 feet LT to 60 feet RT. The Engineer has determined this material meets the criteria of and shall be managed in accordance with Article 669.05(a)(1). Contaminants of concern sampling parameters: Iron, and Manganese.
- Station 1001+70 to Station 1003+30 (CL Ramp B), from 20 feet LT to 60 feet RT. The Engineer has determined this material meets the criteria of and shall be managed in accordance with Article 669.05(a)(2). Contaminants of concern sampling parameters: Lead, and Manganese.
- Station 1003+30 to Station 1004+90 (CL Ramp B), from 25 feet LT to 60 feet RT. The Engineer has determined this material meets the criteria of and shall be managed in accordance with Article 669.05(a)(1). Contaminants of concern sampling parameters: Benzo(a)pyrene, Lead, and Manganese.
- Station 1004+90 to Station 1006+50 (CL Ramp B), from 40 feet LT to 60 feet RT. The Engineer has determined this material meets the criteria of and shall be managed in accordance with Article 669.05(a)(2). Contaminants of concern sampling parameters: Lead, Manganese, and Nickel.

- Station 1006+50 to Station 1009+80 (CL Ramp B), from 50 feet LT to 60 feet RT. The Engineer has determined this material meets the criteria of and shall be managed in accordance with Article 669.05(a)(1). Contaminants of concern sampling parameters: Iron, Lead, and Manganese.
- Station 1011+10 to Station 1012+70 (CL Ramp B), from 70 feet LT to 20 feet RT. The Engineer has determined this material meets the criteria of and shall be managed in accordance with Article 669.05(a)(1). Contaminants of concern sampling parameters: Lead, and Manganese.
- Station 1012+70 to Station 1015+20 (CL Ramp B), from 110 feet LT to 30 feet RT. The Engineer has determined this material meets the criteria of and shall be managed in accordance with Article 669.05(a)(2). Contaminants of concern sampling parameter: Manganese.
- Station 1015+20 to Station 1016+40 (CL Ramp B), from 20 feet LT to 40 feet RT. The Engineer has determined this material meets the criteria of and shall be managed in accordance with Article 669.05(a)(2). Contaminants of concern sampling parameter: Manganese.
- Station 1016+40 to Station 1019+30 (CL Ramp B), from 80 feet LT to 70 feet RT. The Engineer has determined this material meets the criteria of and shall be managed in accordance with Article 669.05(a)(2). Contaminants of concern sampling parameter: Manganese.
- Station 1019+30 to Station 1022+10 (CL Ramp B), from 0 to 100 feet LT. The Engineer has determined this material meets the criteria of and shall be managed in accordance with Article 669.05(a)(3). Contaminants of concern sampling parameters: Benzo(a)pyrene, and Manganese.
- Station 1021+10 to Station 1023+70 (CL Ramp B), from 0 to 60 feet RT. The Engineer has determined this material meets the criteria of and shall be managed in accordance with Article 669.05(a)(3). Contaminants of concern sampling parameters: Benzo(a)pyrene, and Manganese.
- Station 1024+65 to Station 1027+05 (CL Ramp B), from 130 to 180 feet LT. The Engineer has determined this material meets the criteria of and shall be managed in accordance with Article 669.05(a)(2). Contaminants of concern sampling parameters: Lead, and Manganese.
- Station 1030+30 to Station 1033+00 (CL Ramp B), from 40 feet LT to 40 feet RT. The Engineer has determined this material meets the criteria of and shall be managed in accordance with Article 669.05(a)(2). Contaminants of concern sampling parameter: Manganese.

#### East Frontage Road

- Station 20+75 to Station 25+35 (CL E. Frontage Road), from 60 feet LT to 50 feet RT. The Engineer has determined this material meets the criteria of and shall be managed in accordance with Article 669.05(a)(3). Contaminants of concern sampling parameters: Benzo(a)pyrene, Dibenzo(a,h)anthracene, and Manganese.
- Station 29+90 to Station 32+25 (CL E. Frontage Road), from 15 feet LT to 50 feet RT. The Engineer has determined this material meets the criteria of and shall be managed in accordance with Article 669.05(a)(3). Contaminants of concern sampling parameters: Benzo(a)pyrene, and Manganese.
- Station 34+75 to Station 37+40 (CL E. Frontage Road), from 25 feet LT to 30 feet RT. The Engineer has determined this material meets the criteria of and shall be managed in accordance with Article 669.05(a)(3). Contaminants of concern sampling parameter: Benzo(a)pyrene.

Ramp D

- Station 11+60 to Station 16+00 (CL Ramp D), from 60 feet LT to 110 feet RT. The Engineer has determined this material meets the criteria of and shall be managed in accordance with Article 669.05(a)(2). Contaminants of concern sampling parameters: Arsenic, and Manganese.

SB I-55 Mainline

- Station 1075+50 to Station 1076+25 (CL SB I-55 Mainline), from 45 to 90 feet LT. The Engineer has determined this material meets the criteria of and shall be managed in accordance with Article 669.05(a)(2). Contaminants of concern sampling parameter: Manganese.
- Station 1076+25 to Station 1082+60 (CL SB I-55 Mainline), from 45 to 90 feet LT. The Engineer has determined this material meets the criteria of and shall be managed in accordance with Article 669.05(a)(1). Contaminants of concern sampling parameters: Benzo(a)pyrene, Dibenzo(a,h)anthracene, and Manganese.
- Station 1082+60 to Station 1084+30 (CL SB I-55 Mainline), from 45 to 90 feet LT. The Engineer has determined this material meets the criteria of and shall be managed in accordance with Article 669.05(a)(3). Contaminants of concern sampling parameters: Benzo(a)pyrene, and Dibenzo(a,h)anthracene.
- Station 1085+90 to Station 1087+50 (CL SB I-55 Mainline), from 45 to 90 feet LT. The Engineer has determined this material meets the criteria of and shall be managed in accordance with Article 669.05(a)(2). Contaminants of concern sampling parameter: Manganese.
- Station 1087+50 to Station 1092+55 (CL SB I-55 Mainline), from 45 to 90 feet LT. The Engineer has determined this material meets the criteria of and shall be managed in accordance with Article 669.05(a)(3). Contaminants of concern sampling parameters: Benzo(a)pyrene, Arsenic, and Manganese.

Site 2233V3-70: Vacant Land – 22000 block of Southeast Frontage Road, Joliet, Will County

- Station 11+20 to Station 12+80 (CL E. Frontage Road), from 15 feet LT to 35 feet RT. The Engineer has determined this material meets the criteria of and shall be managed in accordance with Article 669.05(a)(2). Contaminants of concern sampling parameters: Lead, and Manganese.
- Station 12+80 to Station 14+40 (CL E. Frontage Road), from 15 feet LT to 35 feet RT. The Engineer has determined this material meets the criteria of and shall be managed in accordance with Article 669.05(a)(1). Contaminants of concern sampling parameters: Benzo(a)pyrene, Lead, and Manganese.
- Station 14+40 to Station 16+00 (CL E. Frontage Road), from 15 feet LT to 35 feet RT. The Engineer has determined this material meets the criteria of and shall be managed in accordance with Article 669.05(a)(2). Contaminants of concern sampling parameters: Lead, Manganese, and Nickel.
- Station 16+00 to Station 19+20 (CL E. Frontage Road), from 15 feet LT to 35 feet RT. The Engineer has determined this material meets the criteria of and shall be managed in accordance with Article 669.05(a)(1). Contaminants of concern sampling parameters: Iron, Lead, and Manganese.

Site 2233V3-71: Vacant Land – 22000 block of Southeast Frontage Road, Joliet, Will County

- Station 9+45 to Station 11+20 (CL E. Frontage Road), from 15 feet LT to 35 feet RT. The Engineer has determined this material meets the criteria of and shall be managed in accordance with Article 669.05(a)(1). Contaminants of concern sampling parameters: Iron, and Manganese.

Site 2233V3-72: Vacant Land – 22000 block of Southeast Frontage Road, Joliet, Will County

- Station 4+85 to Station 9+45 (CL E. Frontage Road), from 15 feet LT to 40 feet RT. The Engineer has determined this material meets the criteria of and shall be managed in accordance with Article 669.05(b)(1).

**Work Zones**

Three distinct OSHA HAZWOPER work zones (exclusion, decontamination, and support) shall apply to projects adjacent to or within sites with documented leaking underground storage tank (LUST) incidents, or sites under management in accordance with the requirements of the Site Remediation Program (SRP), Resource Conservation and Recovery Act (RCRA), or Comprehensive Environmental Response, Compensation and Liability Act (CERCLA), or as deemed necessary. For this project, the work zones apply for the following ISGS PESA Sites: **None**

**STABILIZED CONSTRUCTION ENTRANCE**

**Description.** This work shall consist of the furnishing, installation, maintenance and removal of all stabilized construction entrances which are used to reduce or eliminate the tracking of sediment onto public right-of-ways or streets. Construction entrances shall be used in conjunction with the stabilization of construction roads and other exposed areas.

**Materials.** All materials shall conform to the applicable requirements of Materials, Division 1000 and specific references as follows:

Coarse Aggregate .....	Article 1004
Filter Fabric .....	Article 1080

**Construction Requirements.** Stabilized construction entrances shall consist of 12 inches of CA-1 Aggregate placed over filter fabric. The filter fabric shall be included with this pay item. The aggregate shall be crushed stone or crushed gravel.

All surface water flowing or diverted toward the construction entrance shall be piped across the entrance. Pipe used for this will not be paid for, but shall be included in the work. The stabilized construction entrance will have positive drainage away from the roadway.

Maintenance shall consist of placing additional aggregate of the same type and gradation as the base aggregate. Additional aggregate will not be paid for, but shall be included in the work.

After the stabilized construction entrances have served their purpose, the suitable aggregate shall be removed, and, at the direction and approval of the Engineer, utilized for embankment construction or otherwise disposed of as specified in Article 202.03 of the Standard Specifications.

**Method of Measurement.** This work will be measured for payment for payment in place and the area computed in square yards.

**Basis of Payment.** Payment for STABILIZED CONSTRUCTION ENTRANCE will be made at the Contract unit price per square yard, measured as specified.

### **TREE REMOVAL DATE RESTRICTION**

**Description.** Add the following to Article 201.04 of the Standard Specifications:

“No tree removal or tree clearing shall occur from April 1 to October 31 due to IDOT’s commitment to protect the Northern Long-Eared Bat (NLEB).”

### **TREE REMOVAL, ACRES (SPECIAL)**

Modified: August 9, 2021

Project objectives and general requirements:

- 100% removal via mechanical and/or hand cutting methods of woody plant material (trees and shrubs).
- Disposal of all cut trees, shrubs, and chips should be hauled off-site.
- Wood chips shall be removed and not blown back onto the site.
- Preservation of all native shrubs and trees that are marked with green flagging.
- Damages to existing vegetation to remain, such as broken limbs, frayed limbs, or other plantings or roadside appurtenances caused by the Contractor’s tree removal or trimming operations shall be repaired at the Contractor’s expense to the satisfaction of the Engineer.
- Protection of soils from compaction, erosion, and disturbance are the Contractor’s responsibility prior to start of work. Any damage caused by Contractor including but not limited to tire ruts, damage to turf, damage to drainage swales, damage to trails, damage to road pavement, etc. shall be repaired by the Contractor at the Contractor’s expense to the satisfaction of the Engineer. This work shall consist of the removal of the existing woven wire fence, which may or may not include barb wired strands at those locations shown on the plans.
- Tree Removal, Acres (Special) shall include removal of typical amounts of litter and debris encountered during tree removal operations.
- No slash shall be left in drainage ways and be blocking drainage structures. No slash shall be left in piles.
- The Engineer shall have the ultimate authority to approve the final condition of slash. In areas where seeding will take place the use of a forestry mower to manage minor woody vegetation, grind slash, stumps under 6”, and any remaining woody plant debris down to the surface of the soil to prepare the site for future seeding.

- The Engineer shall have the ultimate authority to approve the final condition of slash. In areas where seeding will not take place, slash is acceptable at a maximum depth of no more than two (2) inches to act as a mulch. • Tree debris, logs, equipment, etc. should not be stored within clear zone.
- All cut trees and shrubs shall be removed off site within 24 hours.

**Project Preparation.** This shall include preparation of a clearing access plan and identification of sensitive natural resources. Mechanical clearing operations shall not begin until the Engineer indicates that ground conditions are appropriate to commence mechanical work.

Contractor shall contact the Roadside Development Unit at 847-705-4171, at least 2 weeks prior to beginning forestry work for layout.

Contractor shall furnish at time of layout the following as requested: wooden lathe, neon pink ribbon, neon green ribbon, pink marking paint.

A site visit prior to work shall be arranged with the Contractor, Tree Removal Contractor, the Engineer, and the Roadside Development Unit to do a walk through to review vegetation to protect and remain. Extreme care shall be taken when conducting work within the work site to lessen damage to native vegetation to remain.

**Submittals.** Contractor shall provide the Engineer with a list of herbicides, surfactants, water conditioners, dyes, pH balancers, and other chemicals and adjuvants to be used for implementation of this project for prior approval.

Prior to commencement of any work, submit to the Engineer a written description of all mechanical equipment and its intended use during the execution of the work for prior approval.

**Tree Removal and Initial Cut Stump Treatment.** All cutting of material shall be completed via mechanical (e.g., tracked skid-loaders, forestry mowers) and/or hand cutting (chain saws, clearing saws) methods. Any mechanized clearing equipment must be approved for use on the work site prior to its implementation.

In general, mechanical cutting equipment with all steel tracks or a ground pressure rating of greater than 9.0 psi will not be allowed unless the Contractor can adequately demonstrate that the use of such equipment will not cause adverse rutting/soil compaction to the work site and will not damage the pavement adjacent to the work site.

The Engineer may specify certain areas as "HAND CLEAR ONLY" to be avoided by mechanical equipment or access paths. In these areas, the Contractor is prohibited from using mechanical clearing equipment due to sensitive site conditions.

All woody trees and shrubs over two (2) feet in height of any diameter, including protruding stumps or fallen trees within the defined area shall be removed. Any woody vegetation under two (2) feet in height shall be treated with a foliar herbicide or resprout herbicide.



Branches on remaining trees shall be pruned off up to eight (8) feet from the ground.

All stumps shall be cut flat with no sharp points, and less than two (2) inches of surrounding grade shall be treated with an approved resprout herbicide mixed with a marking dye within twenty-four (24) hours of the tree being cut to prevent regrowth from those stumps.

All herbicides shall be applied according to the manufacturer's label specifications. Contractor personnel applying the resprout herbicide shall have a valid pesticide applicator license issued by the Illinois Department of Agriculture.

The resprout herbicide shall be approved by the Engineer. Resprout herbicide shall be labeled to control woody species present within clearing areas. Resprout herbicide shall be included in the cost of TREE REMOVAL, ACRES (SPECIAL).

The Contractor shall maintain copies at the project site of all current pesticide herbicide labels and Material Safety Data Sheets (MSDS) for all chemicals utilized during completion of the work.

**Method of Measurement.** TREE REMOVAL, ACRES (SPECIAL) will be measured in units of 1 square acre. Plan quantities are estimates only. Actual quantities will be measured in place. Agreement to plan quantities will not be allowed.

If the inspection discloses any work as being unsatisfactory, the Engineer will give the Contractor the necessary instructions for correction of same, and the Contractor shall immediately comply with such instructions and correct the unsatisfactory work within forty-eight (48) hours. Work that is not acceptable on the inspection date will not be measured for payment. Individual areas will not be measured for payment if any portion of the area has not been completed to the satisfaction of the Engineer.

**Basis of Payment.** Tree removal shall be paid for at the contract unit price per acre for TREE REMOVAL, ACRES (SPECIAL). Payment for TREE REMOVAL, ACRES (SPECIAL) shall include the cost of all material, equipment, labor, removal, herbicide application, disposal, cleanup, and incidentals required to complete the work as specified herein and to the satisfaction of the Engineer.

## **WEED CONTROL, BASAL TREATMENT**

Modified: December 14, 2017

### Cut Stump Treatment

To control resprouting of cut stumps of susceptible species, spray mixture must consist of 20% Herbicide Type A, 3% Herbicide Type B, and 77% basal oil. Apply with a backpack or knapsack sprayer using low pressures and a solid cone or flat fan nozzle. Spray the root collar area, sides of the stump, and the outer portion of the cut surface including the cambium until thoroughly wet, but not to the point of runoff. Spray mixture concentration should vary with size and susceptibility of species treated. Apply at any time, including winter months, except when snow or water prevent spraying to the ground line.

### Low Volume Basal Bark Treatment

To control susceptible woody plants with stems less than 6 inches in basal diameter, spray mixture must consist of 20 % Herbicide Type A, 3% Herbicide Type B, and 77% bark oil. Apply with a backpack or knapsack sprayer using low pressure and a solid cone or flat fan nozzle. Mixture should be applied from the root collar up to 18 inches. Spray the basal parts of brush and tree trunks in a manner which thoroughly wets the lower stems, including the root collar area, but not to the point of runoff. Herbicide concentration should vary with size and susceptibility of species treated. Apply at any time, including winter months, except when snow or water prevent spraying to the ground line or when stem surfaces are saturated with water.

Bark oil is for low-volume basal bark and stump treatments, to be used only with oil-miscible woody plant herbicides that permit dilution with oil on their labels. Follow all use directions and precautions on the label of the herbicide.

Description: This work shall consist of the application of an herbicide mixture to control undesirable brush areas along highway roadsides. The solution shall apply to areas for low volume basal treatment and cut stump treatment only.

Materials: The mixture shall contain twenty percent (20%) Herbicide Type A, three percent (3%) Herbicide Type B, and seventy-seven percent (77%) bark oil. Substitutions are allowable with herbicides of equal formulation. The mixture shall have the following formulation:

### **Herbicide Type A**

Active Ingredient:

triclopyr: 3,5,6-trichloro-2-pyridinyloxyacetic acid,  
butoxyethyl ester

61.6%

Inert Ingredients

38.4%

TOTAL

100.00%

**Herbicide Type B**

Active Ingredient:

Isopropylamine salt of Imazapyr (2-[4,5-dihydro-4-methyl-4-(1-methylethyl)-5-oxo-1H-imidazol-2-yl]-3-pyridinecarboxylic acid)\* 27.6%

Inert Ingredients 72.4%

TOTAL 100.00%

\*Equivalent to 22.6% (2-[4,5-dihydro-4-methyl-4-(1-methylethyl)-5-oxo-1H-imidazol-2-yl]-3-pyridinecarboxylic acid)  
 or 2 pounds acid per gallon

The Contractor shall submit a certificate, including the following, prior to starting work:

1. The chemical names of the compound and the percentage by volume of the ingredients which must match the above specified formulation.
2. A statement that the material is in a solution which will form a satisfactory emulsion for use when diluted with oil for normal spraying conditions.
3. A statement that the herbicide, when mixed with oil, will be completely soluble and dispersible and remain in suspension with continuous agitation.
4. A statement describing the products proposed for use when the manufacturer of herbicide requires that surfactants, drift control agents, or other additives be used with the product. These tank mix additives shall be used as specified by the manufacturer. Required additives will not be paid for separately.

**All material shall be brought to the spray area in the original, unopened containers supplied by the manufacturer.**

Application Rate: The Basal Treatment solution shall be applied at the rate specified herein. Additional information is located in Cut Stump Treatment and Low Volume Basal Bark Treatment within this contract.

Method of Measurement: Weed Control, Basal Treatment will be measured for payment in gallons of diluted solution applied as specified. The gallons for payment will be determined based on the gallons specified on the label attached to the original container supplied by the manufacturer. The Engineer must be present during the preparation of solution.

Basis of Payment: Weed Control, Basal Treatment will be paid for at the contract unit price per gallon for WEED CONTROL, BASAL TREATMENT.

Bark oil for dilution of the mixture and additives required for application will not be paid for as separate items, but the costs shall be considered as included in the contract price for Weed Control, Basal Treatment and no additional compensation will be allowed.

## **WEED CONTROL, NATIVE LANDSCAPE ENHANCEMENT**

Modified: January 5, 2018

### Description

This work shall consist of controlling and/or removing weeds growing within native landscapes (prairies, savannahs, woodlands, wetlands, etc.). Various methods of weed control (hand weeding, hand trimming, spot spraying, wicking, etc.) may be required depending on the location, type of weeds, and size of weed infestation. These selective weed control areas may not be able to be treated with typical large roadside herbicide spraying equipment. Locations for selective weed control enhancement shall be as shown on plans and as designated by the Engineer.

The undesirable weeds (tree saplings, teasel, thistle, *Phragmites*, cattails, etc.) shall be removed and/ or treated with the appropriate weed control method approved by the Engineer prior to the start of work per location. Multiple weed species may be treated during each site visit. All herbicides shall be approved by the Engineer prior to the start of work.

All selective weed control enhancement areas shall be completed to the satisfaction of the Engineer with equipment, method, and/or herbicide approved by the Engineer. Disposal of material shall be done in accordance with Article 202.03.

### Schedule

Individual weed species may be targeted and shall be spot sprayed during the appropriate growth stage. Weed control must be completed in a timely manner. When the Engineer directs the Contractor to control the weeds, the Contractor must begin the weed control operation within 7 days of notice.

### Equipment and Herbicides

Special equipment such as backpack sprayers, hand sprayers, and hand pruners may be required to conduct spot herbicide treatments and manual removal of weeds in small areas. All equipment shall be approved by the Engineer. The Contractor shall submit a certificate for all herbicides, including the following, prior to starting work:

1. The chemical names of the compound and the percentage by weight of the ingredients.
2. A statement that the material will form a satisfactory emulsion for use when diluted with water for normal spraying conditions.
3. A statement that the herbicide, when mixed with water, will be completely soluble and dispersible and remain in suspension with continuous agitation.
4. A statement describing the products proposed for use when the manufacturer requires that surfactants, drift control agents, or other additives be used with the product. These tank mix additives shall be used as specified by the manufacturer. Required additives will not be paid for separately.

**All material shall be brought to the spray area in the original, unopened containers supplied by the manufacturer.**

### Application Rate

Follow manufacturer's recommendation for the various herbicides.

### Method

All weed control operations are to proceed in the direction of traffic flow.

If weeds or other undesirable vegetation threatens to introduce seed into naturalized areas, smother planted species, or in case of weeds exceeding growth of planted species, at the direction of the Engineer, the weeds shall be: spot sprayed, wicked, hand trimmed or uprooted, raked and removed from the area. Weeds shall be removed in a manner that does not damage the underlying native grasses and forbs.

The cut material from common reed (*Phragmites australis*), teasel species (*Dipsacus* spp.), and thistle species (*Cirsium* spp.) shall be removed and disposed of according to Article 202.03.

Remove litter, including plastic bags, paper, bottles, etc. prior to weed control. All weeds, litter, and debris removal must be complete to the satisfaction of the Engineer and disposed of according to Article 202.03. Damage to the native vegetation, such as ruts or wheel tracks more than 2 inches in depth, other plantings, or highway appurtenances caused by the weed control remediation operation shall be repaired at the Contractor's expense and to the satisfaction of the Engineer.

### Method of Measurement

The work will be measured in acres of surface area cared for to the satisfaction of the Engineer 15 calendar days after the work authorization date.

If the inspection discloses any work as being unsatisfactory, the Engineer will give the Contractor the necessary instructions for correction of same, and the Contractor shall immediately comply with such instructions and correct the unsatisfactory work within 7 calendar days. Removal and disposal of debris will not be measured separately but shall be considered included.

Areas not meeting the satisfaction of the Engineer shall not be measured for payment. Plan quantities are estimates only. Actual quantities will be measured in place. Agreement to plan quantities will not be allowed.

### Basis of Payment

This work will be paid for at the contract unit price per ACRE for WEED CONTROL, NATIVE LANDSCAPE ENHANCEMENT. Payment for Weed Control, Native Landscape enhancement shall include all materials, equipment, labor, removal, disposal and incidentals required to complete the work as specified herein and to the satisfaction of the Engineer.

**STORM WATER POLLUTION PREVENTION PLAN**



**Storm Water Pollution Prevention Plan**



Route	Marked Route	Section Number
Interstate 80 at Interstate 55	FAI 80 (I-80)	FAI 80 21 STRUCTURE 5
Project Number	County	Contract Number
C-91-113-22	Will	62R26

This plan has been prepared to comply with the provisions of the National Pollutant Discharge Elimination System (NPDES) Permit No. ILR10 (Permit ILR10), issued by the Illinois Environmental Protection Agency (IEPA) for storm water discharges from construction site activities.

I certify under penalty of law that this document and all attachments were prepared under my direction or supervision in accordance with a system designed to assure that qualified personnel properly gathered and evaluated the information submitted. Based on my inquiry of the person or persons who manage the system, or those persons directly responsible for gathering the information, the information submitted is, to the best of my knowledge and belief, true, accurate and complete. I am aware that there are significant penalties for submitting false information, including the possibility of fine and imprisonment for knowing violations.

Signature	Date
	6.27.2024

Print Name	Title	Agency
Jose Rios, P.E.	Regional Engineer	Illinois Department of Transportation

**Note:** Guidance on preparing each section of BDE 2342 can be found in Chapter 41 of the IDOT Bureau of Design and Environment (BDE) Manual. Chapter 41 and this form also reference the IDOT Drainage Manual which should be readily available.

**I. Site Description:**

A. Provide a description of the project location; include latitude and longitude, section, town, and range:

The project is located at the Interstate 80 (I-80) and Interstate 55 (I-55) Interchange and Ramps located near Joliet and Shorewood, Will County, Illinois. The project is located in Sections 21, 27, 28 and 34 of Township 35N, Range 9E. The approximate latitude is 41°28'48"N and the longitude is 88°11'49"W.

The design, installation, and maintenance of BMPs at these locations are within an area where annual erosivity (R value) is less than or equal to 160. Erosivity is less than 5 in all two-week periods between October 12 and April 15, which would qualify for construction rainfall erosivity waiver under the US Construction General Permit requirements. At these locations, erosivity is highest in spring to autumn, April 16 - October 11.

B. Provide a description of the construction activity which is the subject of this plan. Include the number of construction stages, drainage improvements, in-stream work, installation, maintenance, removal of erosion measures, and permanent stabilization:

The project consists of construction of Ramp AA on a new alignment with a new bridge structure over I-55 to carry SB I-55 traffic to EB I-80. The project work also includes the reconstruction of the existing I-80 Ramp D/SB I-55 Auxiliary Lane, I-80 Ramp B/NB I-55 Auxiliary and E. Frontage Road in Will County. The work to be performed includes grading work, drainage improvements, erosion control, roadway lighting, pavement marking and signage installation, maintenance of traffic, construction layout, and landscaping. The total project length is approximately 0.59 miles (3,110 ft) along the various ramps.

The work within each stage is detailed below:

Pre-Stage: Install temporary pavement widening as needed along inside shoulders of existing Ramp D. Existing rumble strips along the outside shoulders of I-55 will be filled. Additional work completed outside of the existing travel lanes and not requiring maintenance of traffic may also be completed during pre-stage.

Stage 1: The work area for this stage includes the construction of Ramp AA embankment east and west of I-55,

FAI Route 80 (I-80)  
Project NHHP-HISX(002)  
Section FAI 80 21 STRUCTURE 5  
Will County  
Contract No. 62R26



proposed Ramp AA bridge abutments and center pier, Ramp B / I-55 NB Auxiliary Lane and Retaining Wall, and the off-line portions of Ramp B.

Stage 2A: The work area for this stage includes the completion of the center pier of the proposed Ramp AA over I-55 bridge and all superstructure elements. Reconstruction of the remaining portions of the interchange ramp B pavement and the NB/SB I-55 Auxiliary. Removal and reconstruction of the outside portion of Ramp D and SB I-55 Ramp A, as well as the removal of two overhead sign structures.

Stage 2B: The work area for this stage includes reconstructing the remaining portions of the Ramp D pavement and the off-line Ramp AA Pavement.

Stage 2C: The work area for this stage includes removal of the remaining overhead structures and the installation of the proposed sign structures.

Additional work required in the contract: Reconstruction of the E. Frontage Road reconstruction and I-55 Improvements related to the Ramp AA over I-55 bridge flyover bridge.

Drainage improvements include installation of new roadway culverts, ditch grading and limited storm sewer along the newly constructed barrier walls throughout the reconstruction limits. The design maintains the underlying drainage patterns and outlets.

Erosion and Sediment Control measures include dust control watering, temporary ditch checks, perimeter erosion barrier, inlet filters, aggregate (erosion control), rip rap, erosion control blanket, and temporary seeding. These items shall be installed according to the erosion and sediment control plans prior to commencing land disturbing activities. All erosion and sediment control measures shall be maintained during the construction season as well as the winter months and other times when the project is closed down. Temporary erosion control measures shall be removed once the areas are fully stabilized or to allow installation of the permanent stabilization measures.

Permanent stabilization measures include seeding Class 1B, Class 2A, Class 4 and Class 4B with nitrogen and potassium fertilizer nutrient along with erosion control blanket to be placed on disturbed areas once work is complete. Where possible permanent stabilization should be completed before work is moved to the subsequent stages.

Seeding Class 4B will be used to provide the necessary buffers to existing wetlands and waters of the U.S. (WOUS).

C. Provide the estimated duration of this project:

The estimated duration of the project is 19 months (2 construction seasons) with an anticipated start date of April 2025 and a completion date of October 2026.

The Pre-Stage Traffic Configuration is restricted until April 2025.

D. The total area of the construction site is estimated to be 26 acres.

The total area of the site estimated to be disturbed by excavation, grading or other activities is 26 acres.

E. The following are weighted averages of the runoff coefficient for this project before and after construction activities are completed; see Section 4-102 of the IDOT Drainage Manual:

C=0.61 (Proposed)  
 C= 0.50(Existing)

F. List all soils found within project boundaries; include map unit name, slope information, and erosivity:

Map unit symbol	Map unit name	K Factor



23B	Blount silt loam, Lake Michigan Lobe, 2 to 4 percent slopes	0.37
235A	Bryce silty clay, 0 to 2 percent slopes	0.17
290A	Warsaw Silt Loam, 0 to 2 percent slopes	0.32
314A	Joliet silt loam, 0 to 2 percent slopes	0.37
315A	Channahon silt loam, 0 to 2 percent slopes	0.32
315C2	Channahon silt loam, 4 to 6 percent slopes, eroded	0.43
317A	Millsdale silty clay loam, 0 to 2 percent slopes	0.32
318B	Lorenzo loam, 2 to 4 percent slopes, eroded	0.32
318C2	Lorenzo loam, 4 to 6 percent slopes, eroded	0.28
320A	Frankfort silt loam, 0 to 2 percent slopes	0.37
327C2	Fox silt loam, 4 to 6 percent slopes	0.43
403D	Elizabeth silt loam, 6 to 12 percent slopes	0.32
526A	Grundelein silt loam, 0 to 2 percent slopes	0.32
530D2	Ozaukee silt loam, 6 to 12 percent slopes	0.43
792B	Jasper loam, 2 to 5 percent slopes	0.32
802B	Orthents Loamy 1 to 6 percent slopes	0.37

G. If wetlands were delineated for this project, provide an extent of wetland acreage at the site; see Phase I report:

Wetlands 27A: Area 0.01 Ac / 0 acres of impact  
 Wetlands 29A: Area 0.081 Ac / 0 acres of impact  
 Wetlands 30A: Area 0.335 Ac / 0 acres of impact  
 Wetlands 32B: Area 0.346 Ac / 0.107 acres of impact  
 Wetlands 34B: Area 0.117 Ac / 0 acres of impact

Total impact (Wetland + WOUS) = 0.107 Acres

H. Provide a description of potentially erosive areas associated with this project:

The pavement widening results in grading work of the existing ditches and side slopes through the project limits. Potentially erosive areas may result in these locations until the surfaces are stabilized.

The Ramp AA embankment fill will be subject to erosion though construction and may require additional stabilization measures through construction until the surface is stabilized.

I. The following is a description of soil disturbing activities by stages, their locations, and their erosive factors (e.g., steepness of slopes, length of slopes, etc.):

Pre-Stage: The work area for this stage includes the outside shoulders of I-55 and existing Ramp D extending through the full length of the project. Embankment in this stage will be installed at a 1:4 typical slope and a max slope of 1:3, as required to fit the available Right-of-Way (ROW).

Stage 1: The work area for this stage includes the construction of Ramp AA embankment and proposed bridge abutments and center pier located east and west of Interstate I-55. Additional work in this stage includes construction of the Ramp B / NB I-55 Auxiliary Lane and adjacent retaining wall as well as the E. Frontage Road.

Stages 2A/2B: The work area for these stages includes the remaining portions of the Ramp AA bridge, interchange ramps (SB I-55 Ramp A, Ramp D, Ramp B). Grading work of the proposed embankment, shoulders and roadside ditches result in typical fore slopes of 1:6/1:4 and a max slope of 1:3.

J. See the erosion control plans and/or drainage plans for this contract for information regarding drainage patterns, approximate slopes anticipated before and after major grading activities, locations where vehicles enter or exit the site and controls to prevent offsite sediment tracking (to be added after contractor identifies locations), areas of soil disturbance, the location of major structural and non-structural controls identified in the plan, the location of areas where stabilization practices are expected to occur, surface waters (including wetlands), and locations where storm water is discharged to surface water including wetlands.

K. Identify who owns the drainage system (municipality or agency) this project will drain into:

IDOT

L. The following is a list of General NPDES ILR40 permittees within whose reporting jurisdiction this project is located:

IDOT  
Will County

M. The following is a list of receiving water(s) and the ultimate receiving water(s) for this site. In addition, include receiving waters that are listed as Biologically Significant Streams by the Illinois Department of Natural Resources (IDNR). The location of the receiving waters can be found on the erosion and sediment control plans:

The direct receiving water for the project is the DuPage River (west of I-55) and Rock Run Creek (east of I-55).

The DuPage River and Rock Run Creek are tributaries to the Des Plaines River whose ultimate receiving water is the Illinois River.

The DuPage River and Rock Run Creek, the Des Plaines, and the Illinois River are not identified by the IDNR as "biologically significant streams".

N. Describe areas of the site that are to be protected or remain undisturbed. These areas may include steep slopes (i.e., 1:3 or steeper), highly erodible soils, streams, stream buffers, specimen trees, natural vegetation, nature preserves, etc. Include any commitments or requirements to protect adjacent wetlands.

For any storm water discharges from construction activities within 50-feet of Waters of the U.S. (except for activities for water-dependent structures authorized by a Section 404 permit, describe: a) How a 50-foot undisturbed natural buffer will be provided between the construction activity and the Waters of the U.S. or b) How additional erosion and sediment controls will be provided within that area.

All wetlands and unimpaired Waters of the US located within the ROW adjacent to the ROW will be protected during construction. Wetland exclusion fencing with signs denoting "WETLANDS NO INTRUSION" will be installed prior to any earthwork activities.

O. Per the Phase I document, the following sensitive environmental resources are associated with this project and may have the potential to be impacted by the proposed development. Further guidance on these resources is available in Section 41-4 of the BDE Manual.

None Identified

303(d) Listed receiving waters for suspended solids, turbidity, or siltation.  
The name(s) of the listed water body, and identification of all pollutants causing impairment:

DuPage River:

Aquatic Life is being impaired by phosphorus, arsenic, chloride, methoxychlor, sedimentation, polychlorinated biphenyls, and dissolved oxygen.

The Primary Contact Recreation is being impaired by fecal coliform. Fish Consumption is being impaired by mercury and polychlorinated biphenyls.

Rock Run Creek:

The aquatic life of Rock Run Creek is being impaired by an unknown cause.

Provide a description of how erosion and sediment control practices will prevent a discharge of sediment resulting from a storm event equal to or greater than a twenty-five (25) year, twenty-four (24) hour rainfall event:

Soil Erosion and Sediment Control (SESC) practices such as temporary ditch checks, inlet filters, perimeter erosion barrier, culvert inlet protection - aggregate, temporary erosion control seeding, and temporary erosion control blankets shown on SESC plans will be used to prevent a discharge of sediment into the receiving waters of the DuPage River and Rock Run Creek.



Provide a description of the location(s) of direct discharge from the project site to the 303(d) water body:

None Identified

Provide a description of the location(s) of any dewatering discharges to the MS4 and/or water body:

None Identified

Applicable Federal, Tribal, State, or Local Programs

None Identified

Floodplain

None Identified

Historic Preservation

None Identified

Receiving waters with Total Maximum Daily Load (TMDL) for sediment, total suspended solids, turbidity or siltation

TMDL (fill out this section if checked above)

The name(s) of the listed water body:

Provide a description of the erosion and sediment control strategy that will be incorporated into the site design that is consistent with the assumptions and requirements of the TMDL:

If a specific numeric waste load allocation has been established that would apply to the project's discharges, provide a description of the necessary steps to meet that allocation:

Threatened and Endangered Species/Illinois Natural Areas (INAI)/Nature Preserves

None Identified

Other

None Identified

Wetland

Refer to item G for identified wetlands through the project limits.

P. The following pollutants of concern will be associated with this construction project:

- |  |   |
|--|---|
| <input checked="" type="checkbox"/> Antifreeze / Coolants  | <input checked="" type="checkbox"/> Solid Waste Debris                                |
| <input checked="" type="checkbox"/> Concrete   | <input checked="" type="checkbox"/> Solvents  |
| <input checked="" type="checkbox"/> Concrete Curing Compounds                                      | <input checked="" type="checkbox"/> Waste water from cleaning construction equipments |
| <input checked="" type="checkbox"/> Concrete Truck Waste   | <input type="checkbox"/> Other (Specify) _____  |
| <input checked="" type="checkbox"/> Fertilizers / Pesticides                                       | <input type="checkbox"/> Other (Specify) _____  |
| <input checked="" type="checkbox"/> Paints   | <input type="checkbox"/> Other (Specify) _____  |
| <input checked="" type="checkbox"/> Petroleum (gas, diesel, oil, kerosene, hydraulic oil / fluids) | <input type="checkbox"/> Other (Specify) _____  |
| <input checked="" type="checkbox"/> Soil Sediment  | <input type="checkbox"/> Other (Specify) _____  |

**II. Controls:**

This section of the plan addresses the controls that will be implemented for each of the major construction activities described in Section I.C above and for all use areas, borrow sites, and waste sites. For each measure discussed, the Contractor will be responsible for its implementation as indicated. The Contractor shall provide to the Resident Engineer a plan for the implementation of the measures indicated. The Contractor, and subcontractors, will notify the Resident Engineer of any proposed changes, maintenance, or modifications to keep construction activities compliant with the Permit ILR10. Each such Contractor has signed the required certification on forms which are attached to, and are a part of, this plan:

**A. Erosion and Sediment Controls:** At a minimum, controls must be coordinated, installed and maintained to:

1. Minimize the amount of soil exposed during construction activity;
2. Minimize the disturbance of steep slopes;
3. Maintain natural buffers around surface waters, direct storm water to vegetated areas to increase sediment removal and maximize storm water infiltration, unless infeasible;
4. Minimize soil compaction and, unless infeasible, preserve topsoil.

**B. Stabilization Practices:** Provided below is a description of interim and permanent stabilization practices, including site- specific scheduling of the implementation of the practices. Site plans will ensure that existing vegetation is preserved where attainable and disturbed portions of the site will be stabilized. Stabilization practices may include but are not limited to: temporary seeding, permanent seeding, mulching, geotextiles, sodding, vegetative buffer strips, protection of trees, preservation of mature vegetation, and other appropriate measures. Except as provided below in II.B.1 and II.B.2, stabilization measures shall be initiated **immediately** where construction activities have temporarily or permanently ceased, but in no case more than **one (1) day** after the construction activity in that portion of the site has temporarily or permanently ceases on all disturbed portions of the site where construction will not occur for a period of fourteen (14) or more calendar days.

1. Where the initiation of stabilization measures is precluded by snow cover, stabilization measures shall be initiated as soon as practicable.
2. On areas where construction activity has temporarily ceased and will resume after fourteen (14) days, a temporary stabilization method can be used.

The following stabilization practices will be used for this project:

- |  |   |
|--|---|
| <input checked="" type="checkbox"/> Erosion Control Blanket / Mulching | <input checked="" type="checkbox"/> Temporary Turf (Seeding, Class 7) |
| <input type="checkbox"/> Geotextiles                                   | <input type="checkbox"/> Temporary Mulching                           |
| <input checked="" type="checkbox"/> Permanent Seeding                  | <input type="checkbox"/> Vegetated Buffer Strips                      |
| <input type="checkbox"/> Preservation of Mature Seeding                | <input type="checkbox"/> Other (Specify) _____                        |
| <input checked="" type="checkbox"/> Protection of Trees                | <input type="checkbox"/> Other (Specify) _____                        |
| <input type="checkbox"/> Sodding                                       | <input type="checkbox"/> Other (Specify) _____                        |
| <input checked="" type="checkbox"/> Temporary Erosion Control Seeding  | <input type="checkbox"/> Other (Specify) _____                        |

Describe how the stabilization practices listed above will be utilized during construction:

When temporary pavement is installed in the Pre-Stage and Stage 1, the disturbed area will be stabilized using temporary erosion control seeding and temporary erosion control blanket as shown on ESC plans. Temporary seeding will also be utilized in Stages 2A/2B as work continues on final outside shoulders.

Where possible temporary stabilization of the initial stage should be completed before work is moved to the subsequent stages.

Stabilization controls runoff volume and velocity, peak runoff rates and volumes of discharge to minimize exposed soil, disturbed slopes, sediment discharges from construction, and provides for natural buffers and minimization of soil compaction. Existing vegetated areas where disturbance can be avoided will not require stabilization.

Protection of Trees will be used to protect mature vegetation from construction activities, provide natural barriers and slow runoff velocity to allow suspended particles to settle out of suspension, absorb energy and allow storm water absorption.

Erosion Control Blanket should be applied to slopes for temporary stabilization prior to seasons when temporary seed will not germinate, for example in mid-July or in winter.



Where possible, stabilization of the initial stage should be completed before work is moved to subsequent stages.

Describe how the stabilization practices listed above will be utilized after construction activities have been completed:

Permanent seeding along all unpaved disturbed areas will be installed prior to completion of work.

Seeding class 2A and erosion control blanket will be utilized along the immediate vicinity of the paved surfaces as a salt tolerant seeding mixture.

Seeding class 4B will be used to provide the necessary buffers to existing wetlands and waters of the U.S (WOUS).

Storm Sewer outlets and slopes in excess of 1V:2H will be stabilized with permanent measures such as rip rap.

**C. Structural Practices:** Provided below is a description of structural practices that will be implemented, to the degree attainable, to divert flows from exposed soils, store flows or otherwise limit runoff and the discharge of pollutants from exposed areas of the site. Such practices may include but are not limited to: perimeter erosion barrier, earth dikes, drainage swales, sediment traps, ditch checks, subsurface drains, pipe slope drains, level spreaders, storm drain inlet protection, rock outlet protection, reinforced soil retaining systems, gabions, and temporary or permanent sediment basins. The installation of these devices may be subject to Section 404 of the Clean Water Act.

- |  |   |
|--|---|
| <input type="checkbox"/> Aggregate Ditch                         | <input checked="" type="checkbox"/> Stabilized Construction Exits |
| <input type="checkbox"/> Concrete Revetment Mats                 | <input checked="" type="checkbox"/> Stabilized Trench Flow        |
| <input checked="" type="checkbox"/> Dust Suppression             | <input type="checkbox"/> Slope Mattress                           |
| <input type="checkbox"/> Dewatering Filtering                    | <input type="checkbox"/> Slope Walls                              |
| <input type="checkbox"/> Gabions                                 | <input checked="" type="checkbox"/> Temporary Ditch Check         |
| <input checked="" type="checkbox"/> In-Stream or Wetland Work    | <input type="checkbox"/> Temporary Pipe Slope Drain               |
| <input type="checkbox"/> Level Spreaders                         | <input type="checkbox"/> Temporary Sediment Basin                 |
| <input type="checkbox"/> Paved Ditch                             | <input type="checkbox"/> Temporary Stream Crossing                |
| <input type="checkbox"/> Permanent Check Dams                    | <input type="checkbox"/> Turf Reinforcement Mats                  |
| <input checked="" type="checkbox"/> Perimeter Erosion Barrier    | <input type="checkbox"/> Other (Specify) _____                    |
| <input checked="" type="checkbox"/> Permanent Sediment Basin     | <input type="checkbox"/> Other (Specify) _____                    |
| <input type="checkbox"/> Retaining Walls                         | <input type="checkbox"/> Other (Specify) _____                    |
| <input checked="" type="checkbox"/> Riprap                       | <input type="checkbox"/> Other (Specify) _____                    |
| <input checked="" type="checkbox"/> Rock Outlet Protection       | <input type="checkbox"/> Other (Specify) _____                    |
| <input type="checkbox"/> Sediment Trap                           | <input type="checkbox"/> Other (Specify) _____                    |
| <input checked="" type="checkbox"/> Storm Drain Inlet Protection | <input type="checkbox"/> Other (Specify) _____                    |

Describe how the structural practices listed above will be utilized during construction:

Perimeter Erosion Barrier (PEB) is used along the areas where work areas are adjacent to non-disturbed areas. PEBs intercept sheet flow and settle out sediment upslope while allowing runoff to filter through slowly, and redirect water from slopes or areas of exposed soil. Silt fence should only be used as PEB in areas where work area is higher than the perimeter. Use of silt fence at the top of slope/elevations higher than the work area should always be avoided. If necessary, temporary fence should be used in these locations (where the top of slope/elevation is higher than the work area) in lieu of silt fence.

Temporary ditch checks are proposed along the re-graded ditches where concentrated flows are expected to occur. The spacing of ditch checks shall be as shown on the plans. The height of the ditch checks shall be one foot.

Inlet filters are used for all the inlets, catch basins, and manholes with open grates for the entire duration of the construction. These are installed directly on the drainage structure or under the grate of the drainage structure resting on the lip of the frame. The fabric bag shall hang down into structure.

Culvert inlet protection - aggregate will be provided at locations where surface water is intercepted by a storm sewer culvert as indicated on the plans. This item will consist of stone placed in front of the culvert to prevent the discharge of transported sediment. Avoid using the INLET AND PIPE PROTECTION shown on the Highway Standard Sheets 280001. Straw bales and silt fence should not be used as inlet and pipe protection.

Stabilized Construction Entrances shall be provided at all points of construction ingress/egress where sediment can be tracked onto public roads.

Dust suppression shall be controlled with the use of irrigation or the application of Calcium Chloride. All work associated with installation and maintenance of Stabilized Construction Entrances, and concrete washouts are incidental to the contract.

Riprap outfall protection will remain in place after construction to provide velocity dissipation and minimize erosion at culvert locations.

Stabilized Trench Flow will be utilized along the entire length of the project to control the flow of water from the surrounding areas. Any disturbance to the flow will be fixed immediately. The Contractor should provide to the RE a plan to ensure that a stabilized flow line will be provided during storm sewer construction. The use of a stabilized flow line between installed storm sewer and open disturbance will reduce the potential for off-site discharge of sediment bearing waters, particularly when rain is in the forecast. Lack of an approved plan or failure to comply will result in an ESC Deficiency Deduction.

In-Stream or Wetland Work. This project requires a US Army Corp of Engineers (USACE) 404 permit that will be secured by the department. All conditions of the 404 permit, found in the special provisions, must be followed. As a condition of this permit, the contractor will need to submit an in-stream work plan (including work within wetlands) to the Department for approval. Guidelines on acceptable in-stream work techniques (including work within wetlands) can be found on the USACE website. The USACE defines and determines in-stream work. The cost of all materials and labor necessary to comply with the above provisions to prepare and implement an in-stream work plan (including work within wetlands) will not be paid for separately, but shall be considered as included in the unit bid prices of the contract and no additional compensation will be allowed with the exception of cofferdams, which will be paid for as Cofferdam (Type 1) (In-stream /Wetland work) with a basis of payment of each.

Describe how the structural practices listed above will be utilized after construction activities have been completed:

Riprap outfall protection will remain in place after construction to provide velocity dissipation and minimize erosion at downstream ends culvert locations. Riprap is a permanent stabilization measure that will be installed immediately after a culvert is installed.

All other temporary measures will be removed once the ground is fully stabilized.

#### D. Treatment Chemicals

Will polymer flocculants or treatment chemicals be utilized on this project:  Yes  No

If yes above, identify where and how polymer flocculants or treatment chemicals will be utilized on this project.

**E. Permanent (i.e., Post-Construction) Storm Water Management Controls:** Provided below is a description of measures that will be installed during the construction process to control volume and pollutants in storm water discharges that will occur after construction operations have been completed. The installation of these devices may be subject to Section 404 of the Clean Water Act.

1. Such practices may include but are not limited to: storm water detention structures (including wet ponds), storm water retention structures, flow attenuation by use of open vegetated swales and natural depressions, infiltration of runoff on site, and sequential systems (which combine several practices).



The practices selected for implementation were determined based on the technical guidance in Chapter 41 (Construction Site Storm Water Pollution Control) of the IDOT BDE Manual. If practices other than those discussed in Chapter 41 are selected for implementation or if practices are applied to situations different from those covered in Chapter 41, the technical basis for such decisions will be explained below.

2. Velocity dissipation devices will be placed at discharge locations and along the length of any outfall channel as necessary to provide a non-erosive velocity flow from the structure to a water course so that the natural physical and biological characteristics and functions are maintained and protected (e.g., maintenance of hydrologic conditions such as the hydroperiod and hydrodynamics present prior to the initiation of construction activities).

Description of permanent storm water management controls:

The adjacent Contract 62R28 provides a permanent detention basin at the southwest quadrant of the I-80 and I-55 interchange.

The detention basin is used to detain stormwater runoff resulting from the added impervious area related to the planned improvements.

The detention basin collects storm water runoff from the site and releases the volume at a controlled rate. The difference between the inflow and outflow is stored above ground in the basin until the runoff is released or permeates into the ground.

- F. **Approved State or Local Laws:** The management practices, controls and provisions contained in this plan will be in accordance with IDOT specifications, which are at least as protective as the requirements contained in the IEPA's Illinois Urban Manual. Procedures and requirements specified in applicable sediment and erosion site plans or storm water management plans approved by local officials shall be described or incorporated by reference in the space provided below. Requirements specified in sediment and erosion site plans, site permits, storm water management site plans or site permits approved by local officials that are applicable to protecting surface water resources are, upon submittal of an NOI, to be authorized to discharge under the Permit ILR10 incorporated by reference and are enforceable under this permit even if they are not specifically included in the plan.
- Description of procedures and requirements specified in applicable sediment and erosion site plans or storm water management plans approved by local officials:

None

- G. **Contractor Required Submittals:** Prior to conducting any professional services at the site covered by this plan, the Contractor and each subcontractor responsible for compliance with the permit shall submit to the Resident Engineer a Contractor Certification Statement, BDE 2342A.

1. The Contractor shall provide a construction schedule containing an adequate level of detail to show major activities with implementation of pollution prevention BMPs, including the following items:
  - Approximate duration of the project, including each stage of the project
  - Rainy season, dry season, and winter shutdown dates
  - Temporary stabilization measures to be employed by contract phases
  - Mobilization time-frame
  - Mass clearing and grubbing/roadside clearing dates
  - Deployment of Erosion Control Practices
  - Deployment of Sediment Control Practices (including stabilized cons
  - Deployment of Construction Site Management Practices (including concrete washout facilities, chemical storage, refueling locations, etc.)
  - Paving, saw-cutting, and any other pavement related operations
  - Major planned stockpiling operation
  - Time frame for other significant long-term operations or activities that may plan non-storm water discharges as dewatering, grinding, etc
  - Permanent stabilization activities for each area of the project
2. During the pre-construction meeting, the Contractor and each subcontractor shall provide, as an attachment to their signed Contractor Certification Statement, a discussion of how they will comply with the requirements of the permit in regard to the following items and provide a graphical representation showing location and type of BMPs to be used when applicable:
  - Temporary Ditch Checks - Identify what type and the source of Temporary Ditch Checks that will be installed as part of the project. The installation details will then be included with the SWPPP.
  - Vehicle Entrances and Exits - Identify type and location of stabilized construction entrances and exits to be used and how they will be maintained.



- Material Delivery, Storage and Use - Discuss where and how materials including chemicals, concrete curing compounds, petroleum products, etc. will be stored for this project.
- Stockpile Management - Identify the location of both on-site and off-site stockpiles. Discuss what BMPs will be used to prevent pollution of storm water from stockpiles.
- Waste Disposal - Discuss methods of waste disposal that will be used for this project.
- Spill Prevention and Control - Discuss steps that will be taken in the event of a material spill (chemicals, concrete curing compounds, petroleum, etc.)
- Concrete Residuals and Washout Wastes - Discuss the location and type of concrete washout facilities to be used on this project and how they will be signed and maintained.
- Litter Management - Discuss how litter will be maintained for this project (education of employees, number of dumpsters, frequency of dumpster pick-up, etc.).
- Vehicle and Equipment Fueling - Identify equipment fueling locations for this project and what BMPs will be used to ensure containment and spill prevention.
- Vehicle and Equipment Cleaning and Maintenance - Identify where equipment cleaning and maintenance locations for this project and what BMPs will be used to ensure containment and spill prevention.
- Dewatering Activities - Identify the controls which will be used during dewatering operations to ensure sediments will not leave the construction site.
- Polymer Flocculants and Treatment Chemicals - Identify the use and dosage of treatment chemicals and provide the Resident Engineer with Material Safety Data Sheets. Describe procedures on how the chemicals will be used and identify who will be responsible for the use and application of these chemicals. The selected individual must be trained on the established procedures.
- Additional measures indicated in the plan.

### III. Maintenance:

When requested by the Contractor, the Resident Engineer will provide general maintenance guides (e.g., IDOT Erosion and Sediment Control Field Guide) to the Contractor for the practices associated with this project. Describe how all items will be checked for structural integrity, sediment accumulation and functionality. Any damage or undermining shall be repaired immediately. Provide specifics on how repairs will be made. The following additional procedures will be used to maintain, in good and effective operating conditions, the vegetation, erosion and sediment control measures and other protective measures identified in this plan. It will be the Contractor's responsibility to attain maintenance guidelines for any manufactured BMPs which are to be installed and maintained per manufacture's specifications.

IDOT's Erosion and Sediment Control Field Guide for Construction Inspection (July 1, 2010) is available for reference through the IDOT website at the following Internet address:

<https://idot.illinois.gov/content/dam/soi/en/web/idot/documents/transportation-system/manuals-guides-and-handbooks/highways/environment/erosion-and-sediment-control-field-guide-for-construction-inspection.pdf>

Perimeter Erosion Barrier (PEB) is used to intercept sheet-flow and settle out sediment upslope while allowing runoff to filter through very slowly, and redirect water from slopes or areas of exposed soil. Silt fence should only be used as PEB in areas where the work area is higher than the perimeter. Any damaged or undermining of any erosion or sediment control structures shall be immediately repaired. Inspection shall take place once a week and within 24 hours following every rainfall of over half an inch. Any damage shall be immediately repaired.

Temporary ditch checks are proposed where concentrated flows are expected to occur. The spacing of ditch checks shall be as shown on the plans. The height of the ditch checks shall be one foot.

Inlet filters are used for all inlets, catch basins, and manholes with open grates for the entire duration of the construction. These are installed directly on the drainage structure or under the open grate of a drainage structure resting on the lip of the frame. Fabric bag shall hang down into structure. Inlet filters, as specified in Article 1081-15(h) of the Standard Specification for Road and Bridge Construction (current edition) will be installed at all inlets catch basins, and manholes for the duration of construction. Inspection shall take place once a week and within 24 hours following every rainfall of over half an inch. Inlet filter bags that have accumulated sediment shall be removed, cleaned, and replaced. Any damage shall be immediately repaired.

Culvert Inlet Protection - Aggregate is used only for pipes that are along I-80, exact location are shown in ESC plans. They are installed prior to any earth-disturbing activities. Inlet and pipe protection shown on Highway Standard Sheet 280001 should be avoided and should be comprised of a combination of ditch checks,



temporary erosion control blanket, and temporary seeding. Any damage shall be immediately repaired.

Stabilized Construction Entrances shall be provided of construction ingress/egress where sediment can be tracked onto public roads. The locations of each construction entrance shall be installed as approved by the Engineer. Any observed damage shall be repaired immediately.

Riprap outfall protection is provided as a velocity dissipation device on upstream bank of the creek. Riprap will be replaced due to washout.

Stabilized flow line: The contractor shall provide to the RE a plan to ensure that a stabilized flow line will be provided during storm sewer construction. This is important where new storm sewer connects to existing culverts. The use of a stabilized flow line between installed storm sewer and open disturbance will reduce the potential for the off-site discharge of sediment-bearing waters. Lack of an approved plan or failure to comply may constitute an erosion control Deficiency Deduction.

Permanent seeding is used to stabilize disturbed areas, preventing soil from being carried off-site by storm water runoff or wind after construction is complete. Any damage to the area shall be immediately repaired and reseeded. The suggested areas are shown in the ESC plans.

Temporary erosion control seeding is used to establish quick growing plants to stabilize disturbed areas, preventing soil from being carried off-site by storm water runoff or wind. Stabilization measures must be initiated no more than seven days after construction activity has ceased regardless of when permanent stabilization is anticipated. The suggested areas are shown in the ESC plans.

If a contractor wishes to use a dedicated concrete plant, it is up to the contractor to secure an Industrial Permit for the dedicated concrete plant. The contractor must also submit a plan to the RE detailing how all stormwater associated with the dedicated concrete plant will be kept separate from the stormwater generated by the construction activities. The contractor has to ensure compliance with all requirements of the Industrial Permit.

All Off-site Borrow, Waste, and Use areas are part of the construction site and are to be inspected according to the language in this section.

#### IV. Inspections:

Qualified personnel shall inspect disturbed areas of the construction site including Borrow, Waste, and Use Areas, which have not yet been finally stabilized, structural control measures, and locations where vehicles and equipment enter and exit the site using IDOT Storm Water Pollution Prevention Plan Erosion Control Inspection Report, BC 2259. Such inspections shall be conducted at least once every seven (7) calendar days and within twenty-four (24) hours of the end of a storm or by the end of the following business or work day that is 0.5 inch or greater or equivalent snowfall.

Inspections may be reduced to once per month when construction activities have ceased due to frozen conditions. Weekly inspections will recommence when construction activities are conducted, or if there is 0.5" or greater rain event, or a discharge due to snowmelt occurs.

If any violation of the provisions of this plan is identified during the conduct of the construction work covered by this plan, the Resident Engineer shall notify the appropriate IEPA Field Operations Section office by email at: [epa.swnoncomp@illinois.gov](mailto:epa.swnoncomp@illinois.gov), telephone or fax within twenty-four (24) hours of the incident. The Resident Engineer shall then complete and submit an "Incidence of Non-Compliance" (ION) report for the identified violation within five (5) days of the incident. The Resident Engineer shall use forms provided by IEPA and shall include specific information on the cause of noncompliance, actions which were taken to prevent any further causes of noncompliance, and a statement detailing any environmental impact which may have resulted from the noncompliance. All reports of non-compliance shall be signed by a responsible authority in accordance with Part VI. G of the Permit ILR10.

The Incidence of Non-Compliance shall be mailed to the following address:

Illinois Environmental Protection Agency  
Division of Water Pollution Control  
Attn: Compliance Assurance Section  
1021 North Grand East  
Post Office Box 19276  
Springfield, Illinois 62794-9276

**V. Failure to Comply:**

Failure to comply with any provisions of this Storm Water Pollution Prevention Plan will result in the implementation of a National Pollutant Discharge Elimination System/Erosion and Sediment Control Deficiency Deduction against the Contractor and/or penalties under the Permit ILR10 which could be passed on to the Contractor.



**Contractor Certification Statement**



Prior to conducting any professional services at the site covered by this contract, the Contractor and every subcontractor must complete and return to the Resident Engineer the following certification. A separate certification must be submitted by each firm. Attach to this certification all items required by Section II.G of the Storm Water Pollution Prevention Plan (SWPPP) which will be handled by the Contractor/subcontractor completing this form.

Route	Marked Route	Section Number
Interstate 80 at Interstate 55	FAI 80 (I-80)	FAI 80 21 STRUCTURE 5
Project Number	County	Contract Number
C-91-113-22	Will	62R26

This certification statement is a part of SWPPP for the project described above, in accordance with the General NPDES Permit No. ILR10 issued by the Illinois Environmental Protection Agency.

I certify under penalty of law that I understand the terms of the Permit No. ILR 10 that authorizes the storm water discharges associated with industrial activity from the construction site identified as part of this certification.

Additionally, I have read and understand all of the information and requirements stated in SWPPP for the above mentioned project; I have received copies of all appropriate maintenance procedures; and, I have provided all documentation required to be in compliance with the Permit ILR10 and SWPPP and will provide timely updates to these documents as necessary.

- Contractor
- Sub-Contractor

Signature	Date		
Print Name	Title		
Name of Firm	Phone		
Street Address	City	State	Zip Code

Items which this Contractor/subcontractor will be responsible for as required in Section II.G. of SWPPP

FAI Route 80 (I-80)  
Project NHHP-HISX(002)  
Section FAI 80 21 STRUCTURE 5  
Will County  
Contract No. 62R26

**U.S. ARMY CORPS OF ENGINEERS REGIONAL PERMIT**





**DEPARTMENT OF THE ARMY**  
U.S. ARMY CORPS OF ENGINEERS, CHICAGO DISTRICT  
231 SOUTH LA SALLE STREET, SUITE 1500  
CHICAGO IL 60604-1437

May 22, 2024

Regulatory Branch (LRC-2024-00219)

SUBJECT: Nationwide Permit Authorization for 0.107 acres of Permanent Impacts for the I-80 Interchange at I-55, Will County, Illinois (Latitude 41.486325°N, Longitude - 88.197442°W)

IDOT Contract 62R26

Jose Rios  
Illinois Department of Transportation  
201 West Center Court  
Schaumburg, Illinois 60196

Dear Mr. Rios:

The U.S. Army Corps of Engineers, Chicago District, has completed its review of your pre-construction notification for the above referenced project, dated March 26, 2024, for authorization under the Nationwide Permit (NWP) Number 14 (NWP 14 Linear Transportation Projects), submitted on your behalf by TranSystems. This office has verified that your proposed activity complies with the terms and conditions of the NWP.

This determination covers only your project as described above and in the approved PRE-FINAL project plans titled, "FAI Route 80 (Interstate 80) Interchange at Interstate 55 Section FAI 80 21 Structure 57, Project NHHP-HISX(005) Pavement Reconstruction, Bridge Construction, and Ramp Modifications, Will County", plot date January 19, 2024, prepared by Stantec. Caution must be taken to prevent construction materials and activities from impacting waters of the United States beyond the scope of this authorization. If the design, location, or purpose of the project is changed, it is recommended that you contact this office to determine the need for further authorization.

The subject activity may be performed without further authorization from this office provided that the activity complies with the NWP terms and general conditions, the regional conditions for Illinois, the special conditions listed below, and the Section 401 Water Quality Certification ("WQC") conditions added by the Illinois Environmental Protection Agency ("IEPA"). The NWP Program terms, general conditions, and regional conditions are listed in the enclosed NWP Summary. The WQC conditions are listed in the enclosed Fact Sheet.

Specifically, we wish to draw your attention to General Condition 21, which requires permittees to notify our office immediately in the event of discovery of previously unknown human remains, Native American cultural items, or archaeological artifacts;

- 2 -

and a term of the NWP program, which states that NWPs do not obviate the need to obtain other federal, state, or local permits, approvals, or authorizations required by law.

In addition to the general, regional, and water quality conditions of this permit verification, the following special conditions also apply to this verification:

1. If the work is scheduled to occur between April 1 and September 31 of any year, the bridge/culvert shall be inspected for the presence of Northern Long-Eared bat (*Myotis septentrionalis*) no more than 7 days prior to the start of construction activity to ensure bats have not started to use the area of the bridge proposed for work. If that species is found to be using the structure, the permittee shall immediately contact Shawn Cirton of the U.S. Fish and Wildlife Service, (847) 381-2253, and Patrick VerHalen of the U.S. Army Corps of Engineers, 312-846-5545 or patrick.j.verhalen@usace.army.mil, to ask for further guidance. Work shall not commence until consultation with these two agencies has been satisfied.

2. This authorization is contingent upon implementing and maintaining soil erosion and sediment controls in a serviceable condition throughout the duration of the project. You shall comply with the project's soil erosion and sediment control (SESC) plans and the installation and maintenance requirements of the SESC practices on-site. You shall notify this office any changes or modifications to the approved plan set. Please be aware that field conditions during project construction may require the implementation of additional SESC measures for further protection of aquatic resources. If you fail to implement corrective measures, this office may require more frequent site inspections to ensure the installed SESC measures are acceptable. Please be aware that work authorized herein may not commence until you receive written notification from this office that your plans meet technical standards.

As part of the SESC process, you are required to retain a qualified Independent SESC Inspector (ISI) to review the project's SESC plans and provide a detailed narrative that explains the measures to be implemented at the project site. The ISI is also required to perform site inspections of the implemented SESC measures to ensure proper installation and regular maintenance of the approved methods.

a. You shall contact this office and the ISI at least 10 calendar days prior to the preconstruction meeting so that a representative of this office may attend. The meeting agenda will include a discussion of the SESC plan and the installation and maintenance requirements of the SESC practices on the site;

b. Prior to commencement of any in-stream work, you shall submit construction plans and a detailed narrative to this office that disclose the contractor's preferred method of cofferdam and dewatering method;



- 3 -

- c. The ISI will perform weekly inspections of the implemented SESC measures to ensure proper installation and regular maintenance of the approved methods. The ISI contact information form shall be submitted to this office via e-mail and/or hard copy prior to commencement of the permitted work; and
  - d. The ISI shall submit to the Corps an inspection report with digital photographs of the SESC measures on a weekly basis during the active and non-active phases of construction. An inspection report shall also be submitted at the completion of the project once the SESC measures have been removed and final stabilization has been completed.
3. You are responsible for all work authorized herein and for ensuring that all contractors are aware of the terms and conditions of this authorization.
  4. A copy of this authorization must be present at the project site during all phases of construction.
  5. Upon completion of the work and prior to the submission of the compliance certificate, a copy of the As-Built Plans shall be submitted to the USACE PM at [patrick.j.verhalen@usace.army.mil](mailto:patrick.j.verhalen@usace.army.mil) illustrating the final conditions of the impacted areas.

Please note that IEPA has issued Section 401 Water Quality Certification for this NWP. The conditions of this WQC are automatically conditions of this NWP verification and are included in the enclosed Fact Sheet. If you have any questions regarding Section 401 certification, please contact IEPA's Division of Water Pollution Control, Permit Section #15, by telephone at (217) 785-6939.

This verification is valid until March 14, 2026, when NWP 14 is scheduled to be modified, reissued, or revoked. Furthermore, if you commence or are under contract to commence this activity before the date the NWP is modified, reissued, or revoked, you will have 12 months from the date of the modification, reissuance, or revocation to complete the activity under the present terms and conditions. Failure to comply with the general and regional conditions of this NWP, or any project-specific special conditions of this authorization, may result in the suspension or revocation of your authorization.

This office is in receipt of the IDOT Mitigation Ledger confirming your usage of 0.1605 acres of mitigation credit from the Atkinson Road Mitigation Bank. This requirement was calculated by multiplying 0.107 ac by a ratio of 1.5:1 which equals 0.1605 ac of credits.

Once you have completed the authorized activity, please sign and return the enclosed compliance certification as required by general condition 30. If you have any

- 4 -

questions, please contact Mr. Patrick VerHalen of this office by telephone at (312) 846-5545, or email at patrick.j.verhalen@usace.army.mil.

Sincerely,

Soren G. Hall  Digitally signed by Soren  
G. Hall  
Date: 2024.05.22  
10:01:19 -05'00'

Soren G. Hall  
Team Leader  
Regulatory Branch

Enclosures

cc:

IDOT (Vanessa Ruiz)  
IDOT (Alycia Klueenberg)



- 5 -



**PERMIT COMPLIANCE  
CERTIFICATION**

Permit Number: LRC-2024-00219  
Permittee: Jose Rios  
Illinois Department of Transportation  
Date: May 22, 2024

I hereby certify that the work authorized by the above-referenced permit has been completed in accordance with the terms and conditions of said permit and if applicable, compensatory wetland mitigation was completed in accordance with the approved mitigation plan.<sup>1</sup>

\_\_\_\_\_  
PERMITTEE

\_\_\_\_\_  
DATE

Within 30 days after completion of the activity authorized by this permit and any mitigation required by the permit, this certification must be signed and returned to the following address:

Email to: [ChicagoRequests@usace.army.mil](mailto:ChicagoRequests@usace.army.mil)  
Subject: Compliance Certification, LRC-2024-00219

Please note that your permitted activity is subject to compliance inspections by Corps of Engineers representatives. If you fail to comply with this permit, you may be subject to permit suspension, modification, or revocation.

<sup>1</sup> If compensatory mitigation was required as part of your authorization, you are certifying that the mitigation area has been graded and planted in accordance with the approved plan. You are acknowledging that the maintenance and monitoring period will begin after a site inspection by a Corps of Engineers representative or after thirty days of the Corps' receipt of this certification. You agree to comply with all permit terms and conditions, including additional reporting requirements, for the duration of the maintenance and monitoring period.



## ILLINOIS ENVIRONMENTAL PROTECTION AGENCY

1021 NORTH GRAND AVENUE EAST, P.O. BOX 19276, SPRINGFIELD, ILLINOIS 62794-9276 • (217) 782-3397

JB PRITZKER, GOVERNOR

JOHN J. KIM, DIRECTOR

Corrected Copy

**October 8, 2021**

Corrected Copy Date: **DEC 21 2021**

U.S. Army Corps of Engineers, Rock Island  
ATTN: Ms. Samantha Chavez, Regulatory Branch  
Post Office Box 2004  
Clock Tower Building  
Rock Island, IL 61204-2004

Re: Federal Register [Docket Number: COE-2020-0002] Proposal to Reissue and Modify  
Nationwide Permits, September 15, 2020  
CWA §401 Certification/Denial and applicable conditions  
Illinois EPA Log no. C-0210-20

Dear Ms. Chavez:

On September 15, 2020 the Corps of Engineers issued the notice of proposed rulemaking concerning their determination to reissue and modify the current Nationwide Permits (NWP) that are set to expire on March 18, 2022. By letter dated August 19, 2021 your office extended the reasonable period of time to revise the §401 water quality certification to October 13, 2021 for thirty-two (32) NWP. The Agency has made modifications to the certification conditions issued on December 11, 2020. By this final determination document the Illinois EPA grants §401 water quality certification for NWP 3, 4, 5, 6, 7, 13, 14, 15, 16, 17, 18, 19, 20, 22, 23, 25, 27, 30, 31, 32, 33, 36, 37, 38, 41, 45, 53, and 54 with the special and/or general conditions specified below. This document also provides the certification conditions for NWP 12, 29, 39, 40, 42, 43, 51, 52, 57, and 58 and notice of the Agency determination to deny eight (8) of the proposed nationwide permits which are provided below with reasons in accordance with 40 CFR 121.7(e)(2).

**CWA §401 certification is hereby granted, subject to General Conditions 1 through 12 below, for the following nationwide permits:**

NWP 3 – Maintenance  
NWP 4 – Fish and Wildlife Harvesting, Enhancement, and Attraction Device and Activities  
NWP 5 – Scientific Measurement Devices  
NWP 7 – Outfall Structures and Associated Intake Structures  
NWP 18 – Minor Discharges  
NWP 19 – Minor Dredging  
NWP 20 – Response Operations for Oil or Hazardous Substances  
NWP 22 – Removal of Vessels  
NWP 25 – Structural Discharges  
NWP 30 – Moist Soil Management for Wildlife  
NWP 31 – Maintenance of Existing Flood Control Facilities  
NWP 33 – Temporary Construction, Access and Dewatering  
NWP 36 – Boat Ramps  
NWP 41 – Reshaping Existing Drainage Ditches  
NWP 45 – Repair of Uplands Damaged by Discrete Events

2125 S. First Street, Champaign, IL 61820 (217) 278-5800  
2009 Mall Street Collinsville, IL 62234 (618) 346-5120  
9511 Harrison Street, Des Plaines, IL 60016 (847) 294-4000  
595 S. State Street, Elgin, IL 60123 (847) 608-3131

2309 W. Main Street, Suite 116, Marion, IL 62959 (618) 993-7200  
412 SW Washington Street, Suite D, Peoria, IL 61602 (309) 671-3022  
4302 N. Main Street, Rockford, IL 61103 (815) 987-7760



EPA Log No. C-0210-20, Section 401 Water Quality Certification with General and Special Conditions and Denial of 401 Certification Regarding Federal Register [Docket Number: COE-2020-0002] Proposal to Reissue and Modify Nationwide Permits, September 15, 2020.

Page No. 2

**CWA §401 certification is hereby granted, subject to General Conditions 1 through 12 below and the Special Conditions which are contained in the referenced attachment for the following identified nationwide permits:**

- NWP 6 – Survey Activities. Refer to Special Conditions for NWP 6 in Attachment.
- NWP 12 – Oil or Natural Gas Pipeline Activities. Refer to Special Conditions for NWP 12 in Attachment.
- NWP 13 – Bank Stabilization. Refer to Special Conditions for NWP 13 in Attachment.
- NWP 14 – Linear Transportation Projects. Refer to Special Conditions for NWP 14 in Attachment.
- NWP 15 – U.S. Coast Guard Approved Bridges. Refer to Special Conditions for NWP 15 in Attachment.
- NWP 16 – Return Water from Upland Contained Disposal Areas. Refer to Special Conditions for NWP 16 in Attachment.
- NWP 17 – Hydropower Projects. Refer to Special Conditions for NWP 17 in Attachment.
- NWP 23 – Approved Categorical Exclusions. Refer to Special Conditions for NWP 23 in Attachment.
- NWP 27 – Aquatic Habitat Restoration, Establishment, and Enhancement Activities. Refer to Special Conditions for NWP 27 in Attachment.
- NWP 29 – Residential Developments. Refer to Special Conditions for NWP 29 in Attachment.
- NWP 32 – Completed Enforcement Actions. Refer to Special Conditions for NWP 32 in Attachment.
- NWP 37 – Emergency Watershed Protection and Rehabilitation. Refer to Special Conditions for NWP 37 in Attachment.
- NWP 38 – Cleanup of Hazardous and Toxic Waste. Refer to Special Conditions for NWP 38 in Attachment.
- NWP 39 – Commercial and Institutional Developments. Refer to Special Conditions for NWP 39 in Attachment.
- NWP 40 – Agricultural Activities. Refer to Special Conditions for NWP 40 in Attachment.
- NWP 42 – Recreational Facilities. Refer to Special Conditions for NWP 42 in Attachment.
- NWP 43 – Stormwater Management Facilities. Refer to Special Conditions for NWP 43 in Attachment.
- NWP 51 – Land-Based Renewable Energy Generation Facilities. Refer to Special Conditions for NWP 51 in Attachment.
- NWP 52 – Water-Based Renewable Energy Generation Pilot Projects. Refer to Special Conditions for NWP 52 in Attachment.
- NWP 53 – Removal of Low-Head Dams. Refer to Special Conditions for NWP 53 in Attachment.
- NWP 54 – Living Shorelines. Refer to Special Conditions for NWP 54 in Attachment.
- NWP 57 – Electric Utility Line and Telecommunications Activities. Refer to Special Conditions for NWP 12 in Attachment.
- NWP 58 – Utility Line Activities for Water and Other Substances. Refer to Special Conditions for NWP 12 in Attachment.

**CWA §401 certification is hereby denied with reasons provided in accordance with 401 CFR 121.7 for the following NWPs:**

- NWP 21 – Surface Coal Mining Activities. The Illinois EPA has determined that a case-specific review is warranted for all surface mining activities including carbon extraction because pursuant to 35 Ill. Admin. Code Section 401.102, mining activities are identified as having, when certain refuse materials are used, the capability to cause or threaten to cause a nuisance or render waters harmful or detrimental to public health and to all legitimate uses including but not limited to livestock and wildlife uses. The likelihood that contaminants related to coal extraction, particularly acid producing minerals in mine refuse, would be found within overburden and soil stockpiles and therefore present within fill materials warrant a facility specific antidegradation assessment pursuant to 35 Ill. Admin. Code Section 302.105. Additionally, Illinois' Section 401 implementation rules at 35 Ill. Admin. Code Part 395 regarding material testing exemptions specifically exclude material with known sources of pollution. Therefore, Section 401 certification is denied for this nationwide permit (NWP21).

IEPA Log No. C-0210-20, Section 401 Water Quality Certification with General and Special Conditions and Denial of 401 Certification Regarding Federal Register [Docket Number: COE-2020-0002] Proposal to Reissue and Modify Nationwide Permits, September 15, 2020.

Page No. 3

---

NWP 34 – Cranberry Production Activities: The Illinois EPA has determined that the area of impact that is allowed by an authorization under this nationwide permit exceeds 1/2 acre. 1/2 acre is determined to be representative of the maximum threshold for minimal degradation of existing uses of aquatic resources. Consequently, any activity authorized under this nationwide permit must be subject to a case-specific antidegradation assessment pursuant to 35 Ill. Admin. Code Section 302.105. Therefore, the Illinois EPA denies 401 certification for NWP 34.

NWP 44 – Mining Activities: The Illinois EPA has determined that a case-specific review is warranted for all surface mining activities because pursuant to 35 Ill. Admin. Code Section 401.102, mining activities are identified as having, when certain refuse materials are used, the capability to cause or threaten to cause a nuisance or render waters harmful or detrimental to public health and to all legitimate uses including but not limited to livestock and wildlife uses. Furthermore, all mining activities are regulated by the Illinois EPA under federal and state statute because of their potential to cause or threaten to cause water pollution. Therefore, for the above reasons, the Illinois EPA denies 401 certification for NWP 44.

NWP 46 – Discharges into Ditches: The Illinois EPA has determined that a case-specific review is warranted for all discharge activities into ditches because of the nationwide permit exceeds the 1/2 acreage determined to be the maximum threshold for minimal degradation of existing uses of aquatic resources. Consequently, any activity authorized under this nationwide permit must be subject to a case-specific antidegradation assessment pursuant to 35 Ill. Admin. Code Section 302.105. Therefore, the Illinois EPA denies 401 certification for NWP 46.

NWP 48 – Commercial Shellfish Mariculture Activities: As proposed, the Illinois EPA believes this nationwide permit is inapplicable to waters of the U.S. that are found within the State of Illinois. Therefore, the Illinois EPA denies 401 certification for NWP 48.

NWP 49 – Coal Remining Activities: By reference to the certification denial explanation for NWP 21, the Illinois EPA denies 401 certification for NWP 49.

NWP 50 – Underground Coal Mining: By reference to the certification denial explanation for NWP 21, the Illinois EPA denies 401 certification for NWP 50.

NWP 59 – Water Reclamation and Reuse Facilities: As proposed in the Federal Register, this proposed nationwide permit would appear to allow utilization of existing natural waterbodies as treatment devices. According to 35 Ill. Admin. Code 301.440 such utilization is not permissible. Therefore, the Illinois EPA denies 401 certification for NWP 59.

---

#### 401 Certification General Conditions

---

General Conditions 1 through 12 shall be applicable to all NWPs that are granted 401 certification.

**General Condition 1: Waterbodies that Require Individual Certification**

Pursuant to 35 Ill. Adm. Code Section 302.105(d)(6), an individual 401 water quality certification will be required for activities permitted under these Nationwide Permits for discharges to waters designated by the State of Illinois as waters of particular biological significance or Outstanding Resource Waters under 35 Ill. Adm. Code 302.105(b). Biologically Significant Streams (BSS) are cataloged in Illinois DNR's publication



IEPA Log No. C-0210-20, Section 401 Water Quality Certification with General and Special Conditions and Denial of 401 Certification Regarding Federal Register [Docket Number: COE-2020-0002] Proposal to Reissue and Modify Nationwide Permits, September 15, 2020.

Page No. 4

“Integrating Multiple Taxa in a Biological Stream Rating System” and may be identified at:  
<https://www2.illinois.gov/dnr/conservation/BiologicalStreamratings/Pages/default.aspx>.

**General Condition 2: Water Quality Impairments**

Pursuant to 35 Ill. Adm. Code Sections 302.105(a), 302.105(c)(2)(B), and 395.401(a), an individual 401 water quality certification will be required for activities permitted under these Nationwide Permits that may cause a discharge that, whether temporarily or permanently, may cause or contribute to additional loading of any pollutant, or deterioration of any water quality parameter, such as pH or dissolved oxygen, where such pollutant or parameter is also designated by the State of Illinois as a cause of water quality impairment of the particular segment of the receiving water body according to the Illinois Environmental Protection Agency’s Section 303(d) list. The most recent Illinois Integrated Water Quality Report and Section 303(d) List can be found at <https://www2.illinois.gov/epa/topics/water-quality/watershed-management/tmdls/Pages/303d-list.aspx>.

**General Condition 3: Threatened and Endangered Species**

Pursuant to 35 Ill. Admin. Code Section 302.105(f)(1)(F), prior to proceeding with any work in furtherance of activities permitted under these Nationwide Permits, potential impacts to State threatened or endangered species and Natural Areas shall be determined in accordance with applicable consultation procedures established under 17 Ill. Admin Code Part 1075. The Department of Natural Resources (IDNR) Ecological Compliance Assessment Tool (EcoCAT) is available to complete consultation at <http://dnr.illinois.gov/EcoPublic/>. If IDNR determines that adverse impacts to protected natural resources are likely, the applicant shall address those identified concerns with IDNR through the consultation process. Please contact IDNR, Impact Assessment Section at 217-785-5500 if you have any questions regarding consultation.

**General Condition 4: TMDLs**

Pursuant to 35 Ill. Admin. Code Sections 302.105(a), 302.105(c)(2)(B), and 395.401(a), activities permitted under these Nationwide Permits that may cause a discharge that, whether temporarily or permanently, may cause or contribute to additional loading of any pollutant, or deterioration of any water quality parameter, such as pH or dissolved oxygen, where such pollutant or parameter is addressed by a USEPA approved Total Maximum Daily Load (TMDL) report for the receiving water body shall develop and implement additional measures and or procedures which ensure consistency with the load allocations, assumptions and requirements of the TMDL report. TMDL program information and water listings are available at <https://www2.illinois.gov/epa/topics/water-quality/watershed-management/tmdls/Pages/reports.aspx>.

**General Condition 5: Prohibitions**

Pursuant to 35 Ill. Admin. Code Section 395.401(a), the applicant shall not cause:

- violation of applicable provisions of the Illinois Environmental Protection Act;
- water pollution defined and prohibited by the Illinois Environmental Protection Act;
- violation of applicable water quality standards of the Illinois Pollution Control Board, Title 35, Subtitle C: Water Pollution Rules and Regulation; or
- interference with water use practices near public recreation areas or water supply intakes.

**General Condition 6: Erosion and Sedimentation Control Measures**

Pursuant to the Illinois Environmental Protection Act Section 39(a)[415 ILCS 5/39(a)] and 35 Ill. Admin. Code Sections 302.203 and 395.402(b)(2), the applicant shall implement all necessary sedimentation and erosion control measures consistent with the current edition of

IEPA Log No. C-0210-20, Section 401 Water Quality Certification with General and Special Conditions and Denial of 401 Certification Regarding Federal Register [Docket Number: COE-2020-0002] Proposal to Reissue and Modify Nationwide Permits, September 15, 2020.

Page No. 5

the “Illinois Urban Manual” found at <https://illinoisurbanmanual.org/>. Interim measures to prevent erosion during construction shall be taken and may include the installation of sedimentation basins, silt fencing and temporary mulching. All construction within the waterway shall be conducted during zero or low flow conditions. All areas affected by construction shall be seeded and stabilized as soon after construction as possible.

**General Condition 7: NPDES Stormwater Construction Permit**

Pursuant to the Illinois Environmental Protection Act Section 39(a)[415 ILCS 5/39(a)] and 35 Ill. Admin. Code Section 395.402(b)(2), the applicant shall be responsible for obtaining an NPDES Storm Water Permit required by the federal Clean Water Act prior to initiating construction if the construction activity associated with the project will result in the disturbance of 1 (one) or more acres, total land area. An NPDES Storm Water Permit may be applied for at <https://www2.illinois.gov/epa/topics/forms/water-permits/storm-water/Pages/construction.aspx>.

**General Condition 8: Spill Response Plan**

Pursuant to 35 Ill. Admin. Code Sections 395.401, 302.203, and 302.208, the applicant shall ensure that a spill avoidance and response plan has been developed and implemented for management of accidental releases of petroleum, oil, and lubricant products to the aquatic environment during construction and for emergency notification of applicable downstream water supply operators. Absorbent pads, containment booms and skimmers shall be available to facilitate the cleanup of petroleum spills. If floating hydrocarbon (oil and gas) products are observed, the applicant or his designated individual will be responsible for directing that work be halted so that appropriate corrective measures are taken in accordance with the plan prior to resuming work.

**General Condition 9: Hydraulic Machinery**

Pursuant to 35 Ill. Admin. Code Sections 302.203, 302.304, and 302.515, all hydraulic machinery utilized for the permitted activity and used in or immediately adjacent to waters of the State shall utilize biodegradable or bio-based hydraulic fluids to minimize pollution in the case of broken or leaking hydraulic equipment.

**General Condition 10: Temporary Structures and Work**

Pursuant to 35 Ill. Admin. Code Sections 302.203, 395.204, and 395.401(b), temporary work pads, cofferdams, access roads and other temporary fills are approved provided that such activities are constructed with clean coarse aggregate or non-erodible non-earthen fill material that will not cause siltation. Sandbags, pre-fabricated rigid materials, sheet piling, inflatable bladders and fabric lined basins may be used for temporary facilities. Temporary fills within streams, creeks or rivers shall utilize adequate bypass measures (i.e. dam and pump, flumes, culverts, etc.) to minimize sedimentation and erosion and to maintain normal stream flow during construction.

**General Condition 11: Construction Site Dewatering**

Pursuant to Illinois Environmental Protection Act Section 39(a)[415 ILCS 5/39(a)] and 35 Ill. Admin. Code Section 395.402(b)(2), dewatering of a construction site is authorized provided the dewatering activity is limited to the immediate work area within a cofferdam or otherwise isolated from waters of the State, and the work site is free from sources of contamination including those of natural origin. Dewatering activities shall incorporate Best Management Practices in accordance with the current edition of the “Illinois Urban Manual”



IEPA Log No. C-0210-20, Section 401 Water Quality Certification with General and Special Conditions and Denial of 401 Certification Regarding Federal Register [Docket Number: COE-2020-0002] Proposal to Reissue and Modify Nationwide Permits, September 15, 2020.

Page No. 6

<https://illinoisurbanmanual.org/>. Practice Standard for Dewatering (no. 813) or as otherwise appropriate to ensure that return flows from the dewatering activity are free of unnatural turbidity and floating debris and meet applicable water quality standards. Dewatering or discharge of flush water from construction of drilled piers or boreholes is not authorized and must be conducted in accordance with an NPDES permit issued by the Illinois EPA.

**General Condition 12: Discharged Material Quality**

Pursuant to 35 Ill. Admin. Code Sections 302.203, 302.208, and 395.401(b), any spoil material excavated, dredged or otherwise produced must not be returned to the water body but must be deposited in a self-contained area in compliance with all state statutes. Except as specifically allowed by special condition, any backfilling must be done with clean material that is predominantly sand or larger size material, with no more than 20% passing a #230 U. S. sieve and placed in a manner to prevent violation of applicable water quality standards.

401 Certification Special Conditions

Special Conditions including the conditional exclusions of 401 certification coverage that are listed within the Attachment: "Special Conditions for Illinois EPA 401 Water Quality Certifications of Certain Nationwide Permits" shall be applicable as stated therein.

Should you have any questions or comments regarding the content of this nationwide certification, please contact Darren Gove at 217-782-3362.

Sincerely,

**ORIGINAL SIGNED**

Darin E. LeCrone, P.E.  
Manager, Permit Section  
Division of Water Pollution Control

DEL:DRG:C-0210-20.docx

Attachment: Special Conditions for Illinois EPA 401 Water Quality Certifications of Certain Nationwide Permits Regarding Federal Register [Docket Number: COE-2020-0002] Proposal to Reissue and Modify Nationwide Permits dated September 15, 2020

cc: Records Unit  
CoE, Chicago District  
CoE, Louisville District (Indianapolis Office)  
CoE, Louisville District (Newburgh Regulatory Office)  
CoE, Memphis District  
CoE, St. Louis District  
IDNR, Bartlett  
IDNR, OWR, Chicago  
IDNR, OWR, Springfield  
USEPA, Region 5  
USFWS, Rock Island, Barrington and Marion

IEPA Log No. C-0210-20: Attachment: Special Conditions for Illinois EPA 401 Water Quality Certifications of Certain Nationwide Permits Regarding Federal Register [Docket Number: COE-2020-0002] Proposal to Reissue and Modify Nationwide Permits dated September 15, 2020

Page No. 7

**ILLINOIS EPA WATER QUALITY CERTIFICATION  
SPECIAL CONDITIONS FOR NATIONWIDE PERMIT 14  
Linear Transportation Projects**

1. Pursuant to 35 Ill. Admin. Code Sections 395.401(a), 302.105(a), and 302.105(c)(2)(B), a case-specific (individual) 401 water quality certification from the Illinois EPA will be required for linear transportation activities that cause loss of greater than 500 linear feet of stream channel, as measured along the stream corridor.
2. Pursuant to 35 Ill. Admin. Code Sections 395.401(a), 302.105(a), and 302.105(c)(2)(B), a case-specific (individual) 401 water quality certification from the Illinois EPA will be required for linear transportation activities covered by this nationwide permit that include the temporary or permanent placement of steel or other painted structures within the waterbody as result of demolition work of previous structures.
3. Pursuant to 35 Ill. Admin. Code Sections 395.401(a), 302.105(a), and 302.105(c)(2)(B), a case-specific (individual) 401 water quality certification from the Illinois EPA will be required for new or expanded roadways that affect waterways which are designated by the State of Illinois as having water quality impairments caused by chloride. The most recent Illinois Integrated Water Quality Report and Section 303(d) List can be found at <https://www2.illinois.gov/epa/topics/water-quality/watershed-management/tmdls/Pages/303d-list.aspx>
4. Pursuant to 35 Ill. Admin. Code Sections 302.203 and 395.401(b), any relocated stream channel authorized under this nationwide permit shall be constructed under dry conditions and allowed to fully stabilize prior to the diversion of flow to prevent erosion and sedimentation.



## HIGH LOAD MULTI-ROTATIONAL BEARINGS

Effective: October 13, 1988

Revised: September 2, 2022

Description. This work shall consist of furnishing and installing High Load Multi-Rotational type bearing assemblies at the locations shown on the plans.

High Load Multi-Rotational (HLMR) bearings shall be the type as shown on the plans, which will be one of the following:

- a) Pot Bearings. These bearings shall be manufactured so that the rotational capability is provided by an assembly having a rubber disc of proper thickness, confined in a manner so it behaves like a fluid. The disc shall be installed, with a snug fit, into a steel cylinder and confined by a tight fitting piston. The outside diameter of the piston shall be no more than 0.03 in. (750 microns) less than the inside diameter of the cylinder at the interface level of the piston and rubber disc. The sides of the piston shall be beveled. PTFE sheets, or silicone grease shall be utilized to facilitate rotation of the rubber disc. Suitable brass sealing rings shall be provided to prevent any extrusion between piston and cylinder.
- b) Shear Inhibited Disc Type Bearing. The Structural Element shall be restricted from shear by the pin and ring design and need not be completely confined as with the Pot Bearing design. The disc shall be a molded monolithic Polyether Urethane compound.

These bearings shall be further subdivided into one or more of the following classes:

- 1) Fixed. These allow rotation in any direction but are fixed against translation.
- 2) Guided Expansion. These allow rotation in any direction but translation only in limited directions.
- 3) Non-Guided Expansion. These allow rotation and translation in any direction.

The HLMR bearings shall be of the type and class specified and designed for the loads shown on the plans. The design of the masonry and sole bearing plates are based on detail assumptions which are not applicable to all suppliers and may require modifications depending on the supplier chosen by the Contractor. The overall depth dimension for the HLMR bearings shall be as specified on the plans. The horizontal dimensions shall be limited to the available bearing seat area.

Any modifications required to accommodate the bearings chosen shall be submitted to the Engineer for approval prior to ordering materials. Modifications may include the addition of steel filler plates or the adjustment of beam seat elevations. Adjustments to bridge seat elevations and accompanying reinforcement details shall be approved by the Structural Engineer of Record. Modifications required shall be made at no additional cost to the State. Inverted bearing or center-guided bearing configurations will not be permitted.

The Contractor shall comply with all manufacturer's material, fabrication and installation requirements specified.

All bearings shall be supplied by prequalified manufacturers. The Department will maintain a list of prequalified manufacturers. The Contractor's options are limited to those systems prequalified by the Department on the date that the contract is bid.

Submittals. Shop drawings shall be submitted to the Engineer for approval according to Article 105.04 of the Standard Specifications. All steel filler plate details shall be included in the shop drawings. In addition the Contractor shall furnish certified copies of the bearing manufacturer's test reports on the physical properties of the component materials for the bearings to be furnished and a certification by the bearing manufacturer stating the bearing assemblies furnished conform to all the requirements shown on the plans and as herein specified. Submittals with insufficient test data and supporting certifications will be rejected.

Materials. The materials for the HLMR bearing assemblies shall be according to the following:

- (a) Elastomeric Materials. The rubber disc for Pot bearings shall be according to Article 1083.02(a) of the Standard Specifications.
- (b) Polytetrafluoroethylene (PTFE) Material. The PTFE material shall be according to Article 1083.02(b) of the Standard Specifications, except that it shall be dimpled lubricated with a maximum coefficient of friction of 0.02 on stainless steel. The dimpled and lubricated PTFE surface shall comply with AASHTO 14.7.2. The friction requirement shall be as specified in the Long Term Deterioration Test required for prequalification and the Sliding Friction Test as specified below.
- (c) Stainless Steel Sheets. The stainless steel sheets shall be of the thickness specified and shall be according to Article 1083.02(c).
- (d) Structural Steel. All structural steel used in the bearing assemblies shall be according to AASHTO M 270, Grade 50 (M 270M Grade 345), unless otherwise specified.
- (e) Threaded studs. The threaded stud, when required, shall conform to the requirements of Article 1083.02(d)(4) of the Standard Specifications.

- (f) Polyether Urethane for Disc bearings shall be according to all of the following requirements:

PHYSICAL PROPERTY	ASTM TEST METHOD	REQUIREMENTS	
Hardness, Type D durometer	D 2240	45 Min	65 Max
Tensile Stress, psi (kPa) At 100% elongation, min	D 412	1500 psi (10,350 kPa)	2300 psi (15,900 kPa)
Tensile Stress, psi (kPa) At 200% elongation, min	D 412	2800 psi (19,300 kPa)	4000 psi (27,600 kPa)
Tensile Strength, psi (kPa), min	D 412	4000 psi (27,600 kPa)	6000 psi (41,400 kPa)
Ultimate Elongation, %, min	D 412	350	220
Compression Set 22 hr. at 158 °F (70 °C), Method B %, max	D 395	40	40

The physical properties for a durometer hardness between the minimum and maximum values shown above shall be determined by straight line interpolation.

Design. Bearing details shown on the contract plans are a schematic representation of the bearing. Actual design of the bearing shall be by the bearing manufacturer. The fabricator shall design the HLMR bearings according to the appropriate AASHTO Design Specifications noted on the bridge plans. The bearing shall be designed for the exact parameters specified in the Design Data table.

Fabrication. The bearings shall be complete factory-produced assemblies. They shall provide for rotation in all directions and for sliding, when specified, in directions as indicated on the plans. All bearings shall be furnished as a complete unit from one manufacturing source. All material used in the manufacture shall be new and unused with no reclaimed material incorporated into the finished assembly.

The translation capability for both guided and non-guided expansion bearings shall be provided by means of a polished stainless steel sliding plate that bears on a PTFE sheet bonded and recessed to the top surface of the piston or disc. The sliding element of expansion bearings shall be restrained against movement in the fixed direction by exterior guide bars capable of resisting the horizontal forces or 20 percent of the vertical design load on the bearing applied in any direction, whichever is greater. The sliding surfaces of the guide bar shall be of PTFE sheet and stainless steel. Guiding off of the fixed base, or any extension of the base, will not be permitted.

Structural steel plates shall be fabricated according to Article 505.04(l) of the Standard Specifications. Prior to shipment the exposed edges and other exposed portions of the structural steel plates shall be cleaned and given a corrosion protection coating as specified on the plans and according to the applicable Special Provisions and Articles 506.03 and 506.04 of the Standard Specifications. During cleaning and coating the stainless steel, PTFE sheet and neoprene shall be protected from abrasion and coating material.

PTFE sheets shall be bonded to steel under factory controlled conditions using heat and pressure for the time required to set the epoxy adhesive used. The PTFE sheet shall be free from bubbles and the sliding surface shall be burnished to an absolutely smooth surface.

The steel piston and the steel cylinder for pot bearings shall each be machined from a solid piece of steel. The steel base cylinder shall be either integrally machined, recessed into with a snug fit, or continuously welded to its steel masonry plate. If the sole plate and piston are not one piece, the piston shall be recessed  $\frac{3}{8}$  inch into the sole plate.

If the bottom disc plate or base cylinder is recessed into the masonry plate, the designed thickness of the masonry plate shall take into account the depth of the recess. If the top disc plate is recessed into the sole plate, the designed thickness of the sole plate shall take into account the depth of the recess.

The shear resisting mechanism shall be machined from a solid piece of steel. Connection of the shear resisting mechanism to top and bottom disc plate shall be determined by the bearing fabricator.

Packaging. Each HLMR bearing assembly shall be fully assembled at the manufacturing plant and delivered to the construction site as complete units. The assemblies shall be packaged, crated or wrapped so the assemblies will not be damaged during handling, transporting and shipping. The bearings shall be held together with removable restraints so sliding surfaces are not damaged.

Centerlines shall be marked on both masonry and sole plates for alignment in the field. The bearings shall be shipped in moisture-proof and dust-proof covers.

Performance Testing. The following performance tests are required per lot on the project. A lot size shall be the number of bearings per class (fixed, guided expansion, non-guided expansion) on the project, but not to exceed 25 bearings per class. When multiple sizes of bearings are used on the same contract, they shall be grouped by class when determining lot sizes and amount of bearings to be tested. All tests shall be performed by the manufacturer prior to shipment.

Dimension Check. Each bearing shall be checked dimensionally to verify all bearing components are within tolerances. Failure to satisfy any dimensional tolerance shall be grounds for rejecting the bearing component or the entire bearing assembly.

Clearance Test. This test shall be performed on one bearing per lot. The bearing selected for this test shall be the one with the least amount of clearance based on the dimension check. The bearing assembly shall be loaded to its service limit state rated capacity at its full design rotation but not less than 0.02 radians to verify the required clearances exist. This test shall be performed twice for each bearing with the rotation oriented longitudinally with the bridge once in each direction. Any visual signs of rubbing or binding shall be grounds for rejection of the lot.

Proof Load Test. This test shall be performed on one bearing per lot. The bearing assembly shall be load tested to 150 percent of the service limit state rated capacity at a rotation of 0.02 radians. The load shall be maintained for 5 minutes, removed then reapplied for 5 minutes. If the load drops below the required value during either application, the test shall be restarted from the beginning. This test shall be performed twice for each bearing with the rotation oriented longitudinally with the bridge once in each direction.

The bearing shall be visually examined both during the test and upon disassembly after the test. Any resultant visual defects include, but are not limited to:

1. Extruded or deformed elastomer, polyether urethane, or PTFE.
2. Insufficient clearances such as evidence of metal to metal contact between the pot wall and the top or sole plate.
3. Damaged components such as cracked steel, damaged seal rings, or damaged limiting rings.
4. Bond failure.

If any of the above items are found it shall be grounds for rejection of the lot.

Sliding Friction Test. For expansion bearings, this test shall be performed on one bearing per lot. The sliding surfaces shall be thoroughly cleaned with a degreasing solvent. No lubrication other than that specified for the bearing shall be used. The bearing shall be loaded to its service limit state rated capacity for 1 hour prior to and throughout the duration of the sliding test. At least 12 cycles of plus and minus sliding with an amplitude equaling the smaller of the design displacement and 1 inch (25 mm) shall then be applied. The average sliding speed shall be between 0.1 inch and 1.0 inches (2.5 mm and 25 mm) per minute. The sliding friction coefficient shall be computed for each direction of each cycle and its mean and standard deviation shall be computed for the sixth through twelfth cycles.

The friction coefficient for the first movement and the mean plus two standard deviations for the sixth through twelfth cycles shall not exceed the design value used. In addition, the mean value for the sixth through twelfth cycles shall not exceed 2/3 of the design value used. Failure of either of these shall result in rejection of the lot.

The bearing shall also be visually examined both during and after the testing, any resultant defects, such as bond failure, physical destruction, or cold flow of the PTFE shall also be cause for rejection of the lot.

The Contractor shall furnish a notarized certification from the bearing manufacturer stating the HLMR bearings have been performance tested as specified, and a purchase order prior to fabrication. The purchase order shall contain, as a minimum, the quantity and size of each type of bearing furnished. The notarized certifications and the purchase order shall be submitted in one package to the Engineer of Tests at the Bureau of Materials and Physical Research (126 East Ash Springfield, IL 62704). The Department reserves the right to perform any of the specified tests on one or more of the furnished bearings. If the tested bearing shows failure it shall be replaced and the remaining bearings shall be similarly tested for acceptance at the Contractor's expense.

The manufacturer shall furnish samples of component materials used in the bearings, for testing by the Department, to the Engineer of Tests at the Bureau of Materials and Physical Research (126 East Ash Springfield, IL 62704). The required components shall be those components of HLMR bearings that are consistent with elastomeric bearing components according to Article 1083.04 of the Standard Specifications.

Installation. The HLMR bearings shall be erected according to Article 521.05 of the Standard Specifications.

Exposed edges and other exposed portions of the structural steel plates shall be field painted as specified for Structural Steel.

Basis of Payment. This work will be paid for at the contract unit price each for HIGH LOAD MULTI-ROTATIONAL BEARINGS, POT , FIXED; HIGH LOAD MULTI-ROTATIONAL BEARINGS, POT, GUIDED EXPANSION; HIGH LOAD MULTI-ROTATIONAL BEARINGS, POT, NON-GUIDED EXPANSION; HIGH LOAD MULTI-ROTATIONAL BEARINGS, DISC, FIXED; HIGH LOAD MULTI-ROTATIONAL BEARINGS, DISC, GUIDED EXPANSION; or HIGH LOAD MULTI-ROTATIONAL BEARINGS, DISC, NON-GUIDED EXPANSION of the load capacity specified.

When the fabrication and erection of HLMR bearings is accomplished under separate contracts, the applicable requirements of Article 505.09 shall apply.

Fabricated HLMR bearings and other materials complying with the requirements of this item, furnished and accepted, will be paid for at the contract unit price each for FURNISHING HIGH LOAD MULTI-ROTATIONAL BEARINGS, POT, FIXED; FURNISHING HIGH LOAD MULTI-ROTATIONAL BEARINGS, POT, GUIDED EXPANSION; FURNISHING HIGH LOAD MULTI-ROTATIONAL BEARINGS, POT, NON-GUIDED EXPANSION; FURNISHING HIGH LOAD MULTI-ROTATIONAL BEARINGS, DISC, FIXED; FURNISHING HIGH LOAD MULTI-ROTATIONAL BEARINGS, DISC, GUIDED EXPANSION; or FURNISHING HIGH LOAD MULTI-ROTATIONAL BEARINGS, DISC, NON-GUIDED EXPANSION of the load capacity specified.

Storage and care of fabricated HLMR bearings and other materials complying with the requirements of this item by the Fabrication Contractor beyond the specified storage period, will be paid for at the contract unit price per calendar day for STORAGE OF HIGH LOAD MULTI-ROTATIONAL BEARINGS if a pay item is provided for in the contract, or will be paid for according to Article 109.04 if a pay item is not provided in the contract.

HLMR bearings and other materials fabricated under this item erected according to the requirements of the specifications, and accepted, will be paid for at the contract unit price each for ERECTING HIGH LOAD MULTI-ROTATIONAL BEARINGS, POT, FIXED; ERECTING HIGH LOAD MULTI-ROTATIONAL BEARINGS, POT, GUIDED EXPANSION; ERECTING HIGH LOAD MULTI-ROTATIONAL BEARINGS, POT, NON-GUIDED EXPANSION; ERECTING HIGH LOAD MULTI-ROTATIONAL BEARINGS, DISC, FIXED; ERECTING HIGH LOAD MULTI-ROTATIONAL BEARINGS, DISC, GUIDED EXPANSION; or ERECTING HIGH LOAD MULTI-ROTATIONAL BEARINGS, DISC, NON-GUIDED EXPANSION of the load capacity specified.

### **ERECTION OF CURVED STEEL STRUCTURES**

Effective: June 1, 2007

Description: In addition to the requirements of Article 505.08(e), the following shall apply.

The Contractor or sub-Contractor performing the erection of the structural steel is herein referred to as the Erection Contractor.

Erection Plan: The Erection Contractor shall retain the services of an Illinois Licensed Structural Engineer, experienced in the analysis and preparation of curved steel girder erection plans, for the completion of a project-specific erection plan. The structural engineer, herein referred to as the Erection Engineer, shall sign and seal the erection plan, drawings, and calculations for the proposed erection of the structural steel.

The erection plan shall be complete in detail for all phases, stages, and conditions anticipated during erection. The erection plan shall include structural calculations and supporting documentation necessary to completely describe and document the means, methods, temporary support positions, and loads necessary to safely erect the structural steel in conformance with the contract documents and as outlined herein. The erection plans shall address and account for all items pertinent to the steel erection including such items as sequencing, falsework, temporary shoring and/or bracing, girder stability, crane positioning and movement, means of access, pick points, girder shape, permissible deformations and roll, interim/final plumbness, cross frame/diaphragm placement and connections, bolting and anchor bolt installation sequences and procedures, and blocking and anchoring of bearings. The Erection Contractor shall be responsible for the stability of the partially erected steel structure during all phases of the steel erection.

The erection plans and procedures shall be submitted to the Engineer for review and acceptance prior to starting the work. Review, acceptance and/or comments by the Department shall not be construed to guarantee the safety or final acceptability of the work or compliance with all applicable specifications, codes, or contract requirements, and shall neither relieve the Contractor of the responsibility and liability to comply with these requirements, nor create liability for the Department. Significant changes to the erection plan in the field must be approved by the Erection Engineer and accepted by the Engineer for the Department.

Basis of Payment: This work shall not be paid for separately but shall be included in the applicable pay items according to Article 505.13 of the Standard Specifications.

### **DIAMOND GRINDING AND SURFACE TESTING BRIDGE SECTIONS**

Effective: December 6, 2004

Revised: April 15, 2022

Description. This work shall consist of diamond grinding and surface testing bridge sections.

The bridge section shall consist of the bridge deck plus the bridge approach slab and pavement connector, if present, at each end of the bridge.

Equipment. Equipment shall be according to the following.

- (a) Diamond Grinder. The diamond grinder shall be a self-propelled planing machine specifically designed for diamond saw grinding. It shall be capable of accurately establishing the profile grade and controlling the grinding cross slope. It shall also have an effective means for removing excess material and slurry from the surface and for preventing dust from escaping into the air. The removal of slurry shall be continuous throughout the grinding operation. The slurry shall be disposed of according to Article 202.03.

The grinding head shall be a minimum of 4 ft. (1.2 m) wide and the diamond saw blades shall be gang mounted on the grinding head at a rate of 50 to 60 blades / ft. (164 to 197 blades/m).

- (b) Surface Testing Equipment. Required surface testing and analysis equipment and their jobsite transportation shall be provided by the Contractor. The Profile Testing Device shall be according to Illinois Test Procedure 701 except the trace analysis shall be based on traces from bridge sections.



## CONSTRUCTION REQUIREMENTS

General. After all components have been properly cured, the bridge section shall be ground over its entire length and over a width that extends to within 2 ft. (600 mm) of the curbs or parapets. Grinding shall be done separately before any saw cut grooving, and no concurrent combination of the two operations will be permitted. Whenever possible, each subsequent longitudinal grinding pass shall progress down the cross slope from high to low. The maximum thickness removed shall be 1/4 inch (6 mm); however, when the bridge deck thickness noted on the plans can be maintained, as a minimum, additional removal thickness may be permitted.

The grinding process shall produce a pavement surface that is true in grade and uniform in appearance with longitudinal line-type texture. The line-type texture shall contain corrugations parallel to the outside pavement edge and present a narrow ridge corduroy type appearance. The peaks of the ridges shall be 1/8-inch +/- 1/16-inch (3 mm +/- 1.5 mm) higher than the bottom of the grinding with evenly spaced ridges. It shall be the Contractor's responsibility to select the actual number of blades per foot (meter) to be used to provide the proper surface finish for the aggregate type and concrete present on the project within the limits specified above.

The vertical difference between longitudinal passes shall be 1/8 inch (3 mm) maximum. The grinding at the ends of the bridge section shall be diminished uniformly at a rate of 1:240 over the pavement connectors.

Grinding shall be continuous through all joints. All expansion joints and bridge components under the joints shall be protected from damage or contact with the grinding slurry.

Surface Testing. The diamond ground bridge section shall be surface tested in the presence of the Engineer prior to opening to traffic.

A copy of the approval letter and recorded settings from the Profile Equipment Verification (PEV) Program shall be submitted to the Engineer prior to testing.

The Contractor shall notify the Engineer a minimum of 24 hours prior to commencement of measurements. All objects and debris shall be removed from the bridge section surface prior to testing. During surface testing, joint openings may be temporarily filled with material approved by the Engineer.

Profiles shall be taken in both wheel paths of each lane, 3 ft. (1 m) from, and parallel to, the planned lane lines.

The profile report shall have stationing indicated every 500 ft. (150 m) at a minimum. The profile report shall include the following information: contract number, structure number, beginning and ending stationing, which lane was tested, direction of travel on the trace, date of collection, time of collection, ambient air temperature at time of collection, and the device operator name(s). The data file created from the testing will be submitted to the Engineer and the Bureau of Research for analysis. The file shall be in a format that is compatible with ProVAL software (ERD, PPF).

Trace Reduction and Bump Locating Procedure. All traces shall be reduced using ProVal. This software shall calculate the Mean International Roughness Index (MRI) in inches/mile (mm/km) and indicate any areas of localized roughness in excess of 200 inches/mile (3105 mm/km) on a continuous 25 feet (8 meters) basis.

The average MRI and locations with deviations exceeding the 200 inches/mile (3105 mm/km) limit will be recorded on the Profile Report for Bridge Deck Smoothness.

All ProVAL files shall be provided to the Engineer within two working days of completing the testing. Bureau of Construction Form BC 2450 shall be provided to the Engineer. An example Form BC 2450 is attached. All files shall contain serial numbers for the vehicle and profiling equipment, the approved settings from the PEV program. The Engineer will compare these settings with the approved settings from the PEV Program. If the settings do not match, the results will be rejected and the section shall be retested/reanalyzed with the appropriate settings.

Corrective Actions. Within the bridge section, all deviations in excess of 200 inches/mile (1575 mm) within any continuous length of 25 ft. (8 m) shall be corrected. Correction of deviations shall not result in the deck thickness being less than the minimum. Where corrective work is performed, the bridge section shall be retested to verify that corrections have produced a MRI of 200 inch/mile (3105 mm/km) within an continuous length of 25 ft (8 m) or less for each lane. The Contractor shall furnish and Form BC 2450 the ProVAL files to the Engineer and the Bureau of Research within two working days after any corrections are made.

Corrective actions shall be performed at no additional cost to the department.

The Engineer may perform profile testing on the surface at any time for monitoring and comparison purposes.

Method of Measurement. This work will be measured for payment in place and the area computed in square yards (square meters) of diamond grinding performed.

Basis of Payment. This work will be paid for at the contract unit price per square yard (square meter) for DIAMOND GRINDING (BRIDGE SECTION).

**Instructions for Completing Bridge Deck Smoothness Assessment Summary ALR**

This form shall be prepared and submitted, along with the raw data files, to the Engineer.

Report Type:

Initial – Testing of bridge section prior to any smoothness grinding.

Intermediate – After initial pass of smoothness grinding has been completed.

Final – All smoothness grinding has been completed.

Other information:

Submission Date – Date in which it has been submitted to the Engineer

Project Type – New Deck, Microsilica Overlay, Latex Overlay, Fly Ash Overlay

Specification Effective Date – revision date of the specification in the contract

Begin ALR Section 1 – beginning station of ALR finding

End ALR Section 1 – end station of ALR finding

Distance – End ALR minus the Begin ALR station number

MRI – The value of the ALR at that location.



**Bridge Deck Smoothness Assessment Summary**  
**Areas of Localized Roughness**

*This worksheet is intended as a reference for documenting Areas of Localized Roughness (ALR) as described in GBSP-59.*

Contract Information		Contact Info			
Contract	60111	IDOT RE Name	Jerry Jones		
District	1	IDOT RE E-Mail	<a href="mailto:Jerry.Jones2@illinois.gov">Jerry.Jones2@illinois.gov</a>		
Letting Date	1/15/2022	IDOT RE Phone	217-555-4183		
Item #	26	Contractor Rep. Name	Bob Builder		
Route	IL 164	Contractor Rep. E-Mail	<a href="mailto:Bob.Builder@RTBRConstr.com">Bob.Builder@RTBRConstr.com</a>		
Report Type (Initial or Post Grinding)	Initial	Contractor Rep. Phone	217-555-2822		
Lane	Driving	<b>General Comments</b>			
Direction	Eastbound				
Begin Station	13+45.00				
End Station	14+65.00				
Contractor	Bob the Bridge Builder				
Submission Date	4/1/2022				
Overlay Type	Microsilica				
Specification Effective Date	1/1/2022				
Begin ALR Section 1	13+56.00			<i>Distance (ft)</i>	<i>MRI (in/mi)</i>
End ALR Section 1	13+64.20			8.2	256.40
Begin ALR Section 2	14+04.60	1.4	278.90		
End ALR Section 2	14+06.00				
Begin ALR Section 3					
End ALR Section 3					
Begin ALR Section 4					
End ALR Section 4					
Begin ALR Section 5					
End ALR Section 5					
Begin ALR Section 6					
End ALR Section 6					
Begin ALR Section 7					
End ALR Section 7					
Begin ALR Section 8					
End ALR Section 8					
Begin ALR Section 9					
End ALR Section 9					
Begin ALR Section 10					
End ALR Section 10					

### **SLIPFORM PARAPET**

Effective: June 1, 2007

Revised: April 15, 2022

The following shall be added to the end of Article 503.16(b) of the Standard Specifications.

- (3) Slipforming parapets. Unless otherwise prohibited herein or on the plans, at the option of the Contractor, concrete parapets on bridge decks may be constructed by slipforming in lieu of the conventional forming methods. Slipforming will not be permitted for curved parapets on a radius of 1500 ft (457 m) or less.

The slipform machine shall be self-propelled and have automatic horizontal and vertical grade control. For 34 in. (864 mm) and 39 in. (991 mm) tall parapets the machine shall be equipped with a minimum of four (4) vibrators. For 42 in. (1.067 m) and 44 in. (1.118 m) tall parapets the machine shall be equipped with a minimum of five (5) vibrators. The equipment shall be approved by the Engineer before use.

If the Contractor wishes to use the slipform parapet option for 42 in. (1.067 m) or 44 in. (1.118 m) tall parapets he/she shall construct an acceptable test section in a temporary location to demonstrate his/her ability to construct the parapets without defect. The test section shall be constructed under similar anticipated weather conditions, using the same means and methods, equipment, equipment vibrator settings, travel speed, operator, concrete plant, concrete mix design, and slump as proposed for the permanent slipform parapets.

The test section shall be at least 30 feet (9 meters) in length and shall be of the same cross section shown on the plans. The contractor shall place all of the reinforcement embedded in the parapet as shown on the plans. Upon completion of the test section, the Contractor shall saw cut the test section into 2 ft (600 mm) segments and separate the segments for inspection by the Engineer. Test sections containing segments showing voids adjacent to a reinforcement bar, 1/4 square inch (160 square millimeters) or more in area and extending along the reinforcement bar into the section, or showing excessive voids not adjacent to reinforcement bars 1/4 square inch (160 square millimeters) or more in area, or showing cracking extending through a segment, shall be considered unacceptable.

The test section shall demonstrate to the satisfaction of the Engineer that the Contractor can slipform the parapets on this project without defects. The acceptance of the test section does not constitute acceptance of the slipform parapets in place.

The concrete mix design may combine two or more coarse aggregate sizes, consisting of CA-7, CA-11, CA-13, CA-14, and CA-16, provided a CA-7 or CA-11 is included in the blend in a proportion approved by the Engineer.

The slipform machine travel speed shall not exceed the lesser of 3 ft (0.9 m) per minute, or the speed used to construct the acceptable test section. Any time the speed of the machine drops below 0.5 ft (150 mm) per minute will be considered a stoppage of the slipforming operation, portions of parapet placed with three or more intermittent stoppages within any 15 ft (4.6 m) length will be rejected. The contractor shall schedule concrete delivery to maintain a uniform delivery rate of concrete into the slipform machine. If delivery of concrete from the truck into the slipforming machine is interrupted by more than 15 minutes, the portion of the wall within the limits of the slipform machine will be rejected.

If the Contractor elects to slipform, the parapet cross-sectional area and reinforcement bar clearances shall be revised according to the details for the Concrete Parapet Slipforming Option. In addition, if embedded conduit(s) are detailed, then the contractor shall utilize the alternate reinforcement as detailed.

The use of cast-in-place anchorage devices for attaching appurtenances and/or railings to the parapets will not be allowed in conjunction with slipforming of parapets. Alternate means for making these attachments shall be as detailed on the plans or as approved by the Engineer.

All reinforcement bar intersections within the parapet cross section shall be 100 percent tied utilizing saddle ties, wrap and saddle ties, or figure eight ties to maintain rigidity during concrete placement. At pre-planned sawcut joints in the parapet, Glass Fiber Reinforced Polymer (GFRP) reinforcement shall be used to maintain the rigidity of the reinforcement cage across the proposed joints as detailed for the Concrete Parapet Slipforming Option.

Glass Fiber Reinforced Polymer (GFRP) reinforcement shall be subject to approval by the Engineer. Other non-ferrous reinforcement may be proposed for use but shall be subject to approval by the Engineer. GFRP reinforcement shall be tied the same as stated in the previous paragraph.

The Contractor may propose supplemental reinforcement for stiffening to prevent movement of the reinforcement cage and/or for conduit support subject to approval by the Engineer.

Clearances for these bars shall be the same as shown for the required bars and these bars shall be epoxy coated. If the additional reinforcement is used, it shall be at no additional cost to the Department.

For projects with plan details specifying parapet joints spaced greater than 20 ft (6 m) apart, additional sawcut joints, spaced between 10 ft (3 m) and 20 ft (6 m), shall be placed as directed by the Engineer. The horizontal reinforcement extending through the proposed joints shall be precut to provide a minimum of 4 in. (100 mm) gap, centered over the joint, between rebar ends. The ends of the reinforcement shall be repaired according to Article 508.04.

After the slipform machine has been set to proper grade and prior to concrete placement, the clearance between the slipform machine inside faces and reinforcement bars shall be checked during a dry run by the Contractor in the presence of the Engineer. The dry run shall not begin until the entire reinforcing cage has been tied and the Engineer has verified and approved the placement and tying of the reinforcing bars. Any reinforcement bars found to be out of place by more than ½ in. (13 mm), or any dimensions between bars differing from the plans by more than ½ in. (13 mm) shall be re-tied to the plan dimensions.

During the dry run and in the presence of the Engineer, the Contractor shall check the clearance of the reinforcement bars from the inside faces of the slipform mold. In all locations, the Contractor shall ensure the reinforcement bars have the minimum cover distance shown on the plans. This dry run check shall be made for the full distance that is anticipated to be placed in the subsequent pour. Reinforcement bars found to have less than the minimum clearance shall be adjusted, and the dry run will be performed again, at least in any locations that have been readjusted.

For parapets adjacent to the watertable, the contractor shall, for the duration of the construction and curing of the parapet, provide and maintain an inspection platform along the back face of the parapet. The inspection platform shall be rigidly attached to the bridge superstructure and be of such design to allow ready movement of inspection personnel along the entire length of the bridge.

The aluminum cracker plates as detailed in the plans shall be securely tied in place and shall be coated or otherwise treated to minimize their potential reaction with wet concrete. In lieu of chamfer strips at horizontal and vertical edges, radii may be used. Prior to slipforming, the Contractor shall verify proper operation of the vibrators using a mechanical measuring device subject to approval by the Engineer.

The top portion of the joint shall be sawcut as shown in the details for the Concrete Parapet Slipforming Option. Sawing of the joints shall commence as soon as the concrete has hardened sufficiently to permit sawing without excessive raveling. All joints shall be sawed to the full thickness before uncontrolled shrinkage cracking takes place, but no later than 8 hours after concrete placement. The sawcut shall be approximately 3/8 in. (10 mm) wide and shall be performed with a power circular concrete saw. The joints shall be sealed with an approved polyurethane sealant, conforming to ASTM C 920, Type S, Grade NS, Class 25, Use T, to a minimum depth of 1/2 in. (12 mm), with surface preparation and installation according to the manufacturer's written instructions. Cork, hemp, or other compressible material may be used as a backer. The sawcut will not require chamfered edges.

Ends of the parapet shall be formed and the forms securely braced. When slipforming of parapets with cross sectional discontinuities such as light standards, junction boxes or other embedded appurtenances except for name plates, is allowed, the parapet shall be formed for a minimum distance of 4 ft (1.2 m) on each side of the discontinuity.

For acceptance and rejection purposes a parapet section shall be defined as the length of parapet between adjacent vertical parapet joints.

The maximum variance of actual to proposed longitudinal alignment shall not exceed  $\pm 3/4$  in. (20 mm) with no more than 1/4 inch in 10 ft (6 mm in 3 m). Notwithstanding this tolerance, abrupt variance in actual alignment of 1/2 inch in 10 ft (13 mm in 3 m) will be cause for rejection of the parapet section.

In addition, all surfaces shall be checked with a 10 ft (3 m) straight edge furnished and used by the Contractor as the concrete is extruded from the slipform mold. Continued variations in the barrier surface exceeding 1/4 in. in 10 ft (6 mm in 3 m) will not be permitted and remedial action shall immediately be taken to correct the problem.

The use of equipment or methods which result in dimensions outside the tolerance limits shall be discontinued. Parapet sections having dimensions outside the tolerance limits will be rejected.

Any visible indication that less than specified cover of concrete over the reinforcing bars has been obtained, or of any cracking, tearing, or honeycombing of the plastic concrete, or any location showing diagonal or horizontal cracking will be cause for rejection of the parapet section in which they are found.

The vertical surfaces at the base of the barrier within 3 in. (75 mm) of the deck surface shall be trowelled true after passage of the slipform machine. Hand finishing of minor sporadic surface defects may be allowed at the discretion of the Engineer. All surfaces of the parapet except the top shall receive a final vertical broom finish. Any deformations or bulges remaining after the initial set shall be removed by grinding after the concrete has hardened.

Slipformed parapets shall be wet cured according to either Article 1020.13(a)(3) or Article 1020.13(a)(5). For either method, the concrete surface shall be covered within 30 minutes after it has been finished. The cotton mat or burlap covering shall be held in place with brackets or another method approved by the Engineer. The Contractor shall have the option, during the period from April 16 through October 31, to delay the start of wet curing by applying a linseed oil emulsion curing compound. Exercising this option waives the requirement for protective coat according to Article 503.19. The linseed oil emulsion shall be according to Article 1022.01 and shall be applied according to Articles 1020.13 Notes-General 8/ and 1020.13(a)(4). The delay for wet curing shall not exceed 3 hours after application of the linseed oil emulsion.

A maximum of three random 4 in. (100 mm) diameter cores per 100 ft (30 m) of parapet shall be taken as directed by the Engineer, but no less than two random cores shall be taken for each parapet pour. At least one core shall be located to intercept a horizontal bar in the upper half of the parapet. Unless otherwise directed by the Engineer, coring shall be accomplished within 48 hours following each parapet pour. Separate parapets poured on the same date shall be considered separate pours. Random cores will not be measured for payment.

The Engineer will mark additional locations for cores where, in the sole opinion of the Engineer, the quality of the slipformed parapet is suspect.



The Engineer or his/her representative will be responsible for evaluation the cores. Any cores showing voids adjacent to a reinforcement bar 1/4 square inch (160 square millimeters) or more in area and extending along the reinforcement bar into the section, or showing excessive voids not adjacent to reinforcement bars 1/4 square inch (160 square millimeters) or more in area, or showing cracking, shall be considered unacceptable and the parapet section from which it was taken will be rejected. Parapets with less than 1½ inches of concrete cover over the reinforcement shall be rejected.

Rejected parapet sections shall be removed and replaced for the full depth cross-section of the parapet except that concrete cover between 1 inch and 1½ inches may be open to remedial action subject to the approval of the Engineer. Such action could entail up to and including removal and replacement.

The minimum length of parapet removed and replaced shall be 3 ft (1 m). Cores may be required to determine the longitudinal extent of removal and replacement if it can not be determined and agreed upon by other means (i.e. visual, sounding, non-destructive testing, etc.).

Any parapet section with more than one half of its length rejected or with remaining segments less than 10 ft (3 m) in length shall be removed and replaced in its entirety.

If reinforcement bars are damaged during the removal and replacement, additional removal and replacement shall be done, as necessary, to ensure minimum splice length of replacement bars. Any damage to epoxy coating of bars shall be repaired according to Article 508.04.

All remaining core holes will be filled with a non-shrink grout meeting the requirements of Section 1024.

Basis of Payment. When the Contractor, at his/her option, constructs the parapet using slipforming methods, no adjustment in the quantities for Concrete Superstructures and Reinforcement Bars, Epoxy Coated to accommodate this option will be allowed. Compensation under the contract bid items for Concrete Superstructures and Reinforcement Bars, Epoxy Coated shall cover the cost of all work required for the construction of the parapet and any test section(s) required, and for any additional costs of work or materials associated with slipforming methods.

## **BRIDGE DECK CONSTRUCTION**

Effective: October 22, 2013

Revised: December 21, 2016

When Diamond Grinding of Bridge Sections is specified, hand finishing of the deck surface shall be limited to areas not finished by the finishing machine and to address surface corrections according to Article 503.16(a)(2). Hand finishing shall be limited as previously stated solely for the purpose of facilitating a more timely application of the curing protection. In addition the requirements of 503.16(a)(3)a. and 503.16(a)(4) will be waived.

### **Revise the Second Paragraph of Article 503.06(b) to read as follows.**

“When the Contractor uses cantilever forming brackets on exterior beams or girders, additional requirements shall be as follows.”

### **Revise Article 503.06(b)(1) to read as follows.**

“(1) Bracket Placement. The spacing of brackets shall be per the manufacturer’s published design specifications for the size of the overhang and the construction loads anticipated. The resulting force of the leg brace of the cantilever bracket shall bear on the web within 6 inches (150 mm) of the bottom flange of the beam or girder.”

### **Revise Article 503.06(b)(2) to read as follows.**

“(2) Beam Ties. The top flange of exterior steel beams or girders supporting the cantilever forming brackets shall be tied to the bottom flange of the next interior beam. The top flange of exterior concrete beams supporting the cantilever forming brackets shall be tied to the top flange of the next interior beam. The ties shall be spaced at 4 ft (1.2 m) centers. Permanent cross frames on steel girders may be considered a tie. Ties shall be a minimum of 1/2 inch (13 mm) diameter threaded rod with an adjusting mechanism for drawing the tie taut. The ties shall utilize hanger brackets or clips which hook onto the flange of steel beams. No welding will be permitted to the structural steel or stud shear connectors, or to reinforcement bars of concrete beams, for the installation of the tie bar system. After installation of the ties and blocking, the tie shall be drawn taut until the tie does not vary from a straight line from beam to beam. The tie system shall be approved by the Engineer.”

### **Revise Article 503.06(b)(3) to read as follows.**

“(3) Beam Blocks. Suitable beam blocks of 4 in x 4 in (100 x 100 mm) timbers or metal structural shapes of equivalent strength or better, acceptable to the Engineer, shall be wedged between the webs of the two beams tied together, within 6 inches (150 mm) of the bottom flange at each location where they are tied. When it is not feasible to have the resulting force from the leg brace of the cantilever brackets transmitted to the web within 6 inches (150 mm) of the bottom flange, then additional blocking shall be placed at each bracket to transmit the resulting force to within 6 inches (150 mm) of the bottom flange of the next interior beam or girder.”

### **Delete the last paragraph of Article 503.06(b).**

**BRIDGE DECK GROOVING (LONGITUDINAL)**

Effective: December 29, 2014

Revised: March 29, 2017

Revise Article 503.16(a)(3)b. to read as follows.

b. Saw Cut Grooving. The grooving operation shall not be started until after the expiration of the required curing or protection period and after correcting excessive variations by grinding or cutting has been completed.

The grooves shall be cut into the hardened concrete, parallel to the centerline of the roadway, using a mechanical saw device equipped with diamond blades that will leave grooves 1/8 in. wide and 3/16 in.  $\pm$  1/16 in. deep (3 mm wide and 5 mm  $\pm$  1.5 mm deep), with a uniform spacing of 3/4 in.  $\pm$  1/16 in. (20 mm  $\pm$  1.5 mm) centers. The grooving shall typically extend the full width of the traffic lanes and terminate at the edge of the traffic lane or shoulder. If the bridge has a variable width traffic lane, the grooving shall remain parallel to the centerline of the main roadway. Any staggering of the groove terminations to accommodate the variable width shall be within the shoulders. Grooves shall not be cut closer than 3 inches (75 mm) nor further than 6 inches (150 mm) from any construction joint running parallel to the grooving. In addition, grooves shall not be cut within 6 in.  $\pm$  1 in. (150 mm  $\pm$  25 mm) from deck drains and expansion joints.

The grooving machine shall contain diamond blades mounted on a multi-blade arbor on a self-propelled machine built for grooving hardened concrete surfaces. The grooving machine shall have a depth control device that detects variations in the deck surface and adjusts the cutting head height to maintain a specified depth of groove. The grooving machine shall have a guide device to control multi-pass alignment.

The removal of slurry shall be continuous throughout the grooving operations. The grooving equipment shall be equipped with vacuum slurry pickup equipment which shall continuously pick up water and sawing dust, and pump the slurry to a collection tank. The slurry shall be disposed of offsite according to Article 202.03.

Cleanup shall be continuous throughout the grooving operation. All grooved areas of the deck shall be flushed with water as soon as possible to remove any slurry material not collected by the vacuum pickup. Flushing shall be continued until all surfaces are clean.

**Method of Measurement.** This work shall be measured for payment according to Article 503.21(b) except no measurement will be made for any grooving of the shoulders to accommodate a variable width traffic lane.

**Basis of Payment.** This work will be paid for at the contract unit price per square yard (square meter) for BRIDGE DECK GROOVING (LONGITUDINAL).

## **METALLIZING OF STRUCTURAL STEEL**

Effective: October 4, 2016

Revised: October 20, 2017

**Description:** This work consists of furnishing all materials, equipment, labor, and other essentials necessary to accomplish the surface preparation and application of thermal spray metallizing to all new structural steel, or portions thereof as detailed in the plans, in the shop. Also included in this work, when specified on the Contract plans, is the application of a paint system over the metallizing in the shop and/or in the field.

**Materials:** Materials shall be according to the following.

**Metallizing Wire:** All thermal spray feedstock (metallizing wire) shall be the products of a single manufacturer, meet the requirements below, and meet the thermal spray equipment manufacturer's specifications.

- a. The metallizing wire shall consist of 99.9% zinc or 85/15 zinc/aluminum complying with ASTM B-833 and ANSI/AWS C2.25/C2.25M
- b. The Contractor shall provide a certificate of chemical composition of the proposed metallizing wire from the metallizing wire manufacturer.

**Paint:** All materials to be used on an individual structure shall be produced by the same manufacturer.

The Bureau of Materials and Physical Research has established a list of all paint products that have met preliminary requirements. Each batch of material, except for the clear aliphatic urethane and the penetrating sealer shall be tested and approved for use. The specified colors shall be produced in the coating manufacturer's facility. Tinting of coating after it leaves the manufacturing facility is not allowed.

The paint materials shall meet the following requirements of the Standard Specification and as noted below:

<u>Item</u>	<u>Article</u>
(a) Waterborne Acrylic	1008.04
(b) Aluminum Epoxy Mastic (Note 1)	1008.03
(c) Epoxy/ Aliphatic Urethane (Note 1)	1008.05
(d) Penetrating Sealer (Note 2)	
(e) Clear Aliphatic Urethane (Note 3)	

Note 1: If the finish coats are being applied in the field over a shop applied epoxy, select an epoxy intermediate for shop application with a recoat window that is long enough to support the construction schedule.

Note 2: The Epoxy Penetrating Sealer shall be a cross-linked multi component sealer. The sealer shall have the following properties:

- (a) The volume solids shall be 98 percent (plus or minus 2 percent).
- (b) Shall be clear or slightly tinted color.

Note 3: The Clear Aliphatic Urethane material shall be one of the following products:

- (a) Carbothane Clear Coat by Carboline Company
- (b) Pitthane Ultra Clear 95-8000 by Pittsburgh Paints (PPG)
- (c) ArmorSeal Rexthane I MCU by Sherwin-Williams

**Shop Prequalification:** The Contractor performing the shop work shall have either an SSPC-QP 3 Certification or an AISC Sophisticated Paint Endorsement certification. The certification(s) shall remain current throughout the duration of the contract.

The Contractor performing the shop work shall have satisfactorily performed a minimum of three (3) previous projects involving abrasive blast cleaning, metallizing, and paint application. At least one project within the past two (2) years shall have involved a bridge or similar industrial type application. The suitability of the Contractor's qualifications and prior experience will be considered by the Department before granting approval to proceed.

**Submittals:** The Contractor performing the shop work shall submit the following plans and information for Engineer review and acceptance within 30 days of contract execution (unless written permission from the Engineer states otherwise). When full coats are being applied in the field, the field painting contractor shall comply with the submittal requirements of Article 506.03. Work in the shop or field shall not proceed until submittals are accepted by the Engineer.

- (a) **Contractor Personnel Qualifications:** Evidence of experience and the names and qualifications/experience/training of the personnel managing and implementing the Quality Control program, and for those performing the quality control tests. QC personnel qualification requirements are found under "Quality Control (QC) Inspection."

All metallizing applicators shall be qualified in accordance with AWS C2.16/C2.16M.

- (b) **Quality Control (QC) Plan:** A Quality Control Plan that identifies: test instruments to be used, a schedule of required measurements and observations, procedures for correcting unacceptable work, and procedures for improving surface preparation and metallizing/painting quality as a result of quality control findings. The program shall incorporate the IDOT Quality Control Daily Report Forms as supplied by the Engineer, or equivalent information on Engineer-approved Shop Contractor-designed forms.
- (c) **Surface Preparation Plan:** The surface preparation plan shall include the methods of surface preparation and types of equipment that will be used to prepare the surfaces as specified herein. Also any solvents proposed for solvent cleaning shall be identified and MSDS provided.

- (d) Abrasives: Identify the type and brand name of the abrasive proposed for use, provide MSDS and manufacturer's data indicating that the abrasive meets requirements of the SSPC-AB 1 or AB 3 standards as specified herein.
- (e) Metallizing Plan: Written procedures for the shop application of metallizing, including the brand name and type of metallizing wire and application equipment to be used. Proof that the metallizing wire complies with ASTM B-833 and ANSI/AWS C2.25/C2.25M shall also be provided. Provide written documentation verifying that all metallizing applicators are qualified in accordance with ANSI/AWS C2.16/C2.16M.
- (f) Painting Plan: If shop painting is specified to be applied over the metallizing or if galvanizing is used in lieu of metallizing on minor bridge members, procedures for the application of the coating system shall be provided along with MSDS and product data sheets. A description of the application equipment to be used shall be included. The plan shall include the requirements to be followed by the field contractor for field touch up.
- (g) Shipping and Handling Plan: A written plan outlining the precautions that shall be taken for the protection of the finished surface during shipping and handling. The plan shall address the steps to be taken, such as insulating padding, wood dunnage, load securing strapping, binding apparatus, etc.
- (h) Galvanizing Option: At the Contractor's option, hot dip galvanizing may be proposed as a substitute for shop metallizing of bearings, typical cross frames, or diaphragms on non-curved structures; expansion joint assemblies; and other elements not carrying calculated stress. Submittal requirements are found under "Hot Dip Galvanizing Option." Include the proposed cleaning and painting plan.

The Engineer will provide written notification to the Contractor when submittals are complete and acceptable. No surface preparation work shall begin until that notification is received. This acceptance shall not be construed to imply approval of any particular method or sequence for conducting the work, or for addressing health and safety concerns. Acceptance does not relieve the Contractor from the responsibility to conduct the work according to the requirements of Federal, State, or Local regulations and this specification, or to adequately protect the health and safety of all workers involved in the project and any members of the public who may be affected by the project. The Contractor remains solely responsible for the adequacy and completeness of the programs and work practices, and adherence to them.

**Quality Control (QC) Inspections**: The Contractor performing the shop work shall perform first line, in process QC inspections. The Contractor shall implement the accepted QC Program to insure that the work complies with these specifications. The designated Quality Control inspector shall be onsite full time during any operations that affect the quality of the system (e.g., surface preparation, metallizing application, paint application, and final inspection at project completion). The Contractor shall use the IDOT Contractor Daily (QC) Metallizing & Painting Report form (supplied by the Engineer, or Engineer-approved Contractor-designed forms that contain the same information, to record the results of quality control tests and inspections. The completed reports shall be given to the Engineer before work resumes the following day.

QC inspections shall include, but are not limited to the following:

- Ambient conditions.
- Surface preparation (solvent cleaning, abrasive blast cleanliness, surface profile depth, etc.).
- Metallizing application (specified materials used, bend test, continuity and coverage, adhesion, dry film thickness).
- Verification that the MISTIC test ID number for the paint system has been issued when painting is specified.
- Paint Application (when specified)(specified materials used, continuity and coverage, dry film thickness, freedom from overspray, dry spray, pinholes, skips, misses, etc.).

The personnel managing the QC Program shall possess a minimum classification as a NACE CIP Level 2, or shall provide evidence of successful inspection of three projects of similar or greater complexity and scope completed in the last two years. References shall include the name, address, and telephone number of a contact person employed by the facility owner.

The personnel performing the QC tests shall be trained in all tests, inspections, and instrument use required for the inspection of surface preparation, metallizing and paint application. Documentation of training shall be provided. The QC personnel shall be solely dedicated to quality control activities and shall not perform any production work. QC personnel shall take the lead in all inspections, but applicators shall perform wet film thickness measurements during application of the coatings, with QC personnel conducting random spot checks. The Contractor shall not replace the QC personnel assigned to the project without advance notice to the Engineer, and acceptance of the replacement(s), by the Engineer.

The Contractor performing the shop work shall supply all necessary equipment to perform the QC tests and inspections as specified. Equipment shall include the following at a minimum:

- Psychrometer or comparable equipment for measurement of dew point and relative humidity, including weather bureau tables or psychrometric charts
- Surface temperature thermometer
- SSPC Visual Standard VIS 1
- Surface profile replica tape and spring micrometer or electronic micrometer designed for use with replica tape; or electronic profilometer designed for measuring blast profile.
- Blotter paper for compressed air cleanliness checks

- Type 2 Electronic Dry Film Thickness Gage
- Calibration standards for dry film thickness gage
- Bend test coupons and bend test mandrel
- Adhesion testing instrument
- Companion panels for adhesion testing (if that option is selected)
- All applicable ASTM, ANSI, AWS, and SSPC Standards used for the work (reference list attached)

The instruments shall be verified for accuracy and adjusted by the Contractor's personnel in accordance with the equipment manufacturer's recommendations and the Contractor's QC Program. All inspection equipment shall be made available to the Engineer for QA observations as needed.

**Hold Point Notification:** Specific inspection and testing requirements within this specification are designated as Hold Points. Unless other arrangements are made, the Contractor shall provide the Engineer with a minimum four-hour notification in advance of the Hold Point. If four-hour notification is provided and the work is ready for inspection at that time, the Engineer will conduct the necessary observations. If the work is not ready at the appointed time, unless other arrangements are made, an additional four-hour notification is required. Permission to proceed beyond a Hold Point without a QA inspection will be at the sole discretion of the Engineer and will only be granted on a case-by-case basis.

**Quality Assurance (QA) Observations:** The Engineer will conduct QA observations of any or all phases of the work. The presence or activity of Engineer observations in no way relieves the Contractor of the responsibility to perform all necessary daily QC inspections of their own and to comply with all requirements of this Specification.

The Engineer has the right to reject any work that was performed without adequate provision for QA observations.

### **CONSTRUCTION REQUIREMENTS**

The surface preparation and metallizing shall be according to the SSPC Specification for the Application of Thermal Spray Coatings (Metallizing) of Aluminum, Zinc and their Alloys and Composites for the Corrosion Protection of Steel, SSPC-CS 23.00/AWS C2.23M/NACE No. 12 except as modified herein. In the event of a conflict, the requirements of this specification shall prevail.



**Hot Dip Galvanizing Option:** At the Contractor's option, hot dip galvanizing may be substituted for shop metallizing of bearings, typical cross frames, or diaphragms on non-curved structures; expansion joint assemblies; and other elements not carrying calculated stress. Galvanized surfaces which shall have concrete poured against them shall be chemically passivated or otherwise protected by a method approved by the Engineer. Galvanized bearings for exterior members and elements readily visible after erection shall be prepared for field painting, but galvanized items obscured from public view will not require field painting. The Contractor shall submit a proposal for substituting galvanizing to the Engineer, showing items to be field painted, applicable provisions of AASHTO M 111 (ASTM A 123), drain/vent holes and any other necessary modifications.

**Notification:** The Contractor shall notify the Engineer 24-hours in advance of beginning surface preparation operations.

**Surface Preparation, Metallizing and Painting Equipment:** The Contractor shall provide surface preparation, metallizing, and painting equipment as needed to perform the work as specified herein.

Metallizing application equipment shall be portable electric arc thermal spray units that are set-up, adjusted and operated in accordance with the manufacturer's written instructions.

All cleaning and painting equipment shall include gages capable of accurately measuring fluid and air pressures and shall have valves capable of regulating the flow of air, water or paint as recommended by the equipment manufacturer. The equipment shall be maintained in proper working order.

Diesel or gasoline powered equipment shall be positioned or vented in a manner to prevent deposition of combustion contaminants on any part of the structure.

Hand tools, power tools, pressure washing, water jetting, abrasive blast cleaning equipment, brushes, rollers, and spray equipment shall be of suitable size and capacity to perform the work required by this specification. Appropriate filters, traps and dryers shall be provided for the compressed air used for abrasive blast cleaning and conventional spray application. Paint pots shall be equipped with air operated continuous mixing devices unless prohibited by the coating manufacturer.

**Test Areas (Sections):** Prior to proceeding with production work on the project, the Contractor shall prepare test sections of at least 10 square feet (0.93 sq. m). More than one test section may be needed to represent the various design configurations of the structure. The test section(s) shall be blast cleaned, metallized and painted (if specified) in accordance with the requirements specified herein using the same equipment, materials and procedures that will be used for the production.

During the blast cleaning, metallizing, and painting of the test section(s), in the presence of the Engineer, the Contractor shall perform all quality control tests and inspections required by this specification including complete documentation. In addition, the Contractor shall allow sufficient time for the Engineer to perform any or all quality assurance tests and inspections desired.

Production work shall not proceed until the Engineer agrees that the blast cleaning, metallizing, and painting work, along with the quality control testing, inspection, and documentation are acceptable.

No additional compensation will be paid for the preparation of the test section(s).

**Protective Coverings and Damage:** The Contractor shall apply protective coverings to all surfaces of the structural steel that are not scheduled for surface preparation, metallizing, and painting. The coverings shall be maintained and remain in place until the work is completed and then shall be removed prior to shipping.

Metallized or painted surfaces damaged by any Contractor's operation shall be repaired, and re-metallized and/or re-painted, as directed by the Engineer, at no additional cost to the Department.

**Ambient Conditions:** Surfaces prepared for metallizing or painting shall be free of moisture and other contaminants. The Contractor shall control operations to insure that dust, dirt, or moisture do not come in contact with surfaces on which work will take place. The surface temperature shall be at least 5°F (3°C) above the dew point during final surface preparation operations, and the application of metallizing. Metallizing shall only be applied when the surface and air temperatures are above 32°F (0°C). The manufacturers' published literature shall be followed for specific temperature, dew point, and humidity restrictions during the application of each paint coat. Metallizing or paint shall not be applied in rain, wind, snow, fog or mist. Ambient conditions shall be maintained during the drying period specified by the manufacturer.

**Compressed Air Cleanliness:** Prior to using compressed air for abrasive blast cleaning, blowing down surfaces, and metallizing or painting application, the Contractor shall verify that the compressed air is free of moisture and oil contamination according to the requirements of ASTM D 4285. The tests shall be conducted at least one time per shift for each compressor system in operation. If air contamination is evident, the Contractor shall change filters, clean traps, add moisture separators or filters, or make other adjustments as necessary to achieve clean, dry air. The Contractor shall also examine the work performed since the last acceptable test for evidence of defects or contamination caused by the contaminated compressed air. Contaminated work shall be repaired at no additional cost to the Department.

**Solvent Cleaning (HOLD POINT):** All traces of oil, grease, and other detrimental contaminants on the steel surfaces to be metallized shall be removed by solvent cleaning in accordance with SSPC-SP 1. The brand name of proposed cleaning solvent(s) and/or proprietary chemical cleaners including manufacturers' product data sheet and MSDS shall be submitted for Engineer acceptance prior to use.

Under no circumstances shall blast cleaning be performed in areas containing surface contaminants or in areas where the Engineer has not accepted the solvent cleaning. Rejected surfaces shall be re-cleaned to the specified requirements at no additional cost to the Department.

**Abrasives:** Abrasive blast cleaning shall be performed using either expendable abrasives or recyclable steel grit abrasives. Expendable abrasives shall be used one time and discarded. The abrasive shall be angular in shape. Acceptable angular shaped abrasives include, but are not limited to, aluminum oxide, steel grit, and crushed slag. Silica sand shall not be used. Steel shot and other abrasives producing a rounded surface profile are not acceptable, even if mixed with angular grit abrasives.

Abrasive suppliers shall provide written certification that expendable abrasives and recyclable steel grit abrasives meet the requirements of SSPC-AB 1 and AB 3, respectively. Abrasive suppliers shall certify that abrasives are not oil contaminated and shall have a water extract pH value within the range of 6 to 8. On a daily basis, the Contractor shall verify that recycled abrasives are free of oil and contamination by performing a vial test in accordance with SSPC-AB 2.

All surfaces that are found to have been prepared using abrasives not meeting the SSPC-AB 1, AB 2, or AB 3 requirements, as applicable, are oil contaminated, or have a pH outside the specified range, shall be solvent cleaned or low pressure water cleaned, and re-blast cleaned at no cost to the Department.

**Surface Preparation (HOLD POINT):** The following method of surface preparation shall be used:

- (a) **Flame Cut Steel:** Prior to blast cleaning, all flame cut edges shall be ground to remove hardened steel and any sharp or irregular shapes.
- (b) **Near-White Metal Blast Cleaning:** All steel surfaces to be metallized shall be near white metal blast cleaned in accordance with SSPC-SP 10 using dry abrasive blast cleaning methods.
- (c) **Galvanized Minor Bridge Members:** If galvanizing of minor bridge members is selected in lieu of metallizing, prepare all galvanized surfaces for painting by brush-off blast cleaning in accordance with SSPC-SP 16 or by using proprietary solutions that are specifically designed to clean and etch (superficially roughed) galvanized steel for painting. If cleaning and etching solutions are selected, submit manufacturer's technical product literature and MSDS for Engineer's review and written acceptance prior to use.

- (d) **Base Metal Irregularities:** If hackles, burrs, or slivers in the base metal are visible on the steel surface after cleaning, the Contractor shall remove them by grinding followed by re-blast cleaning.

**Surface Profile (HOLD POINT):** Blast cleaning abrasives shall be of the size and grade that will produce a uniform angular surface profile depth of 3.5 to 4.5 mils (89 to 114 microns). If the metallizing wire manufacturer's profile requirements are more restrictive, the Contractor shall advise the Engineer and comply with those requirements. For recycled abrasives, an appropriate operating mix shall be maintained in order to control the profile within these limits.

The average surface profile shall be determined each work day with a minimum frequency of one location per every 200 sq ft (18.6 sq m) per piece of equipment. All surfaces, including flame cut edges, shall be tested in accordance with SSPC-PA 17. Surface profile replica tape or electronic profilometer shall be used. The tape shall be retained and included with the daily QC report. Single measurements less than 3.5 mils (89 microns) are unacceptable. In that event, additional testing shall be done to determine the limits of the deficient area and, if it is not isolated, work will be suspended. The Contractor shall submit a plan for making the necessary adjustments to insure that the specified surface profile is achieved on all surfaces. Work shall not resume until the Engineer provides written acceptance.

**Surface Condition Prior to Metallizing (HOLD POINT):** Prepared surfaces shall meet the requirements of SSPC-SP 10 immediately prior to metallizing, and shall be metallized within six hours of blast cleaning. If rust appears or bare steel has been exposed for more than six hours, the affected area shall be re-blasted at no additional cost to the Department.

All dust and surface preparation residue on steel surfaces shall be removed prior to metallizing.

The quality of surface preparation and cleaning of surface dust and debris shall be accepted by the Engineer prior to metallizing.

The Engineer has the right to reject any work that was performed without adequate provision for QA observations to accept the degree of cleaning. Rejected metallizing work shall be removed and replaced at no additional cost to the Department.

**Daily Metallizing Operator-Equipment Qualification – Bend Tests:** Unless directed otherwise by the Engineer, each day that metallizing will be applied, the Contractor shall perform bend testing prior to beginning production work. For each metallizing applicator, five carbon steel coupons measuring 2 inch wide x 8 inch long x 0.05 inch (50mm x400 mm x 1.3 mm) thick shall be blast cleaned using the same equipment and abrasive used for the production work. Each applicator shall apply the metallizing to five coupons in accordance with the requirements of this Specification to a dry film thickness of 8.0 to 12.0 mils (200 to 300µm). 180 degree bend testing shall be performed on all five coupons using a 13mm (1/2") mandrel in accordance with the requirements and acceptance criteria of SSPC-CS 23/AWS C2.23M/NACE 12. Minor cracks that cannot be lifted from the substrate with knife blade are acceptable. If lifting occurs on any coupon, the surface preparation and/or metallizing process shall be modified until acceptable results are achieved before proceeding with production work.

**Application of Metallizing:** Application shall be done in overlapping passes in a cross-hatch pattern (i.e., a second set of overlapping passes shall be applied at right angles to the first set of overlapping passes) to ensure uniform coverage. The gun shall be held at such a distance from the work surfaces that the metal is still molten on impact. The metallizing shall be applied as a continuous film of uniform thickness, firmly adherent, and free from thin spots, misses, lumps or blisters, and have a fine sprayed texture. Thin spots and misses shall be re-metallized. If touch up metallizing or the application of additional metallizing to previously applied metallizing does not occur within 24 hours, the surface of the metallizing shall be brush off blast cleaned according to SSPC-SP7 to remove oxidation and surface contaminants prior to the application of additional metallizing. The final appearance of the metallizing when left un-top coated or top coated with System 1 shall be uniform without excessive blotchiness or contrast in color. If the surface does not have a uniform appearance, remove and replace the metallizing at no cost to the Department. If the configuration of the surface being metallized does not allow for a proper gun-to-work piece standoff distance, the Contractor shall notify the Engineer.

Unless required by the contract plans, the top of the top flanges shall not be metallized or painted. If the contract plans indicate that the top flange is to be metallized, only the first coat of the paint system shall be applied to the top flange.

**Metallizing Thickness:** The thickness of the metallizing shall be 8.0 to 12.0 mils (200-300 microns). Thickness shall be measured as specified by SSPC-PA 2 (use a Type 2 Electronic Gauge only).

**Metallizing Adhesion:** Adhesion testing of metallizing applied each day shall be determined with a self-adjusting adhesion tester in accordance with ASTM D 4541. Unless otherwise directed by the Engineer, a minimum of one test shall be conducted for every 500 sq ft (46sq m) of metallized surface. The tests shall be conducted prior to application of any coating. If any of the tests exhibit less than 700 psi (4.83 MPa) for 85/15 or less than 500 psi (3.45 MPa) for zinc, additional tests shall be conducted to determine the extent of the deficient material. All deficient metallizing shall be removed by blast cleaning and re-applied at no additional cost to the Department.

At the discretion of the Engineer, a representative blast cleaned test panel (or steel companion panel approximately 12 inch x 12 inch x ¼ inch thick) can be metallized at the same time each 500 sq ft (46sq m) of surface area, or portion thereof, is metallized. Adhesion testing can be performed on the companion panel rather than on the structure. If the adhesion tests on the panels are acceptable, the metallizing on the structure is considered acceptable and testing on the structure is not required. If adhesion testing of the panels fails, testing shall be conducted on the structure. If adhesion testing on the structure is acceptable, the metallizing on the structure is considered to be acceptable. If tests on the structure are unacceptable, complete removal of the failing metallizing and re-metallizing in accordance with this Specification shall be performed at no additional cost to the Department.

**Application of Paint Systems Over Metallizing:**

When painting over the metallizing is specified, three painting system options exist for application over the metallizing as shown below. Systems, or components of systems, specified to be shop applied shall not be applied to the faying surfaces of bolted connections. The system to be applied shall be as designated on the plans.

- (a) **System 1** is a single coat system consisting of a full clear aliphatic urethane coat shop applied to all metallized surfaces except as noted above.

The thickness of the clear coat to be applied is dependent on the product selected and shall be as follows:

**TABLE 1**

**CLEAR URETHANE COAT (SINGLE COAT SYSTEM)**

MANUFACTURER	SEALER COAT ONLY (DFT)
Carboline Company	Carbothane Clear Coat  (3.0 to 5.0 mils) (75 to 125 microns)
Pittsburgh Paints (PPG)	Pitthane Ultra Clear 95-8000  (2.0 to 3.0 mils) (50 to 75 microns)
Sherwin-Williams	ArmorSeal Rextthane I MCU  (3.0 to 5.0 mils) (75 to 125 microns)

The clear urethane shall be applied in a 2 step process. The first step shall be to apply a "mist coat" that is thinned at the maximum allowable thinning rate as listed on the manufacturer's product data sheet that is compliant with VOC regulations. The intent of the mist coat is to saturate the porous metallizing surface and displace entrapped air within the porosity of the metallizing. After allowing the mist coat to flash off for 20 minutes, the full coat of clear urethane shall be applied to achieve the manufacturer's recommended dry film thickness.

- (b) **System 2** is a four coat system consisting of a full shop coat of epoxy penetrating sealer coat, a full shop coat of an extended recoat epoxy and two full field applied coats of waterborne acrylic.

The epoxy penetrating sealer shall be applied in accordance with the coating manufacturer's instructions at a coverage rate designed to achieve a theoretical dry film thickness of 1.5 mils (38 microns). The intent of the epoxy penetrating sealer coat is to saturate the metallizing and cover the surface rather than to build a film thickness; therefore, dry film thickness measurement of the epoxy penetrating sealer coat is not required. The top of top flanges that are specified to be metallized and embedded in concrete shall receive the epoxy penetrating sealer only.

The thicknesses of the epoxy and waterborne acrylic coats shall be according to Article 506.09(f)(1).

- (c) **System 3** is a three coat system consisting of a full epoxy penetrating sealer coat, a full epoxy intermediate coat, and a full urethane finish coat. All coats shall be shop-applied unless specified otherwise. If the urethane is field-applied, an extended recoat epoxy shall be applied in the shop.

The epoxy penetrating sealer shall be applied in accordance with the coating manufacturer's instructions at a coverage rate designed to achieve a theoretical dry film thickness of 1.5 mils (38 microns). The intent of the epoxy penetrating sealer coat is to saturate the metallizing and cover the surface rather than to build a film thickness; therefore, dry film thickness measurement of the epoxy penetrating sealer coat is not required. The top of top flanges that are specified to be metallized and embedded in concrete shall receive the epoxy penetrating sealer only.

The thicknesses of the epoxy and urethane coats shall be according to Article 506.09(f)(2).

The single clear urethane coat or the epoxy penetrating sealer coat shall be applied within 24 hours of metallizing providing that the immediate work environment is controlled. If temperature and humidity cannot be controlled, that time frame shall be reduced to within 8 hours. The metallizing shall be dry and free of any visible debris or oxidation (zinc oxide) at the time of application. Visible oxidation shall be removed by mechanical methods such as stiff bristle or wire brushing. Contact surfaces for bolted connections shall consist of bare, uncoated metallizing only and shall be masked off prior to the application of any shop applied coatings.

The clear urethane coat or the epoxy penetrating sealer shall be applied in accordance with the manufacturer's instructions and in such a manner to assure thorough wetting and sealing of the metallizing.

For systems 2 and 3, prior to application of any subsequent coat, the surface of the previous coat shall be dry in accordance with the manufacturer's instructions and free of any visible contamination. If the manufacturer's specified recoat times are exceeded, the effected coat(s) shall be completely roughened or removed and replaced, according to the manufacturer's instructions, at no cost to the Department. The same restrictions regarding film appearance and continuity for the seal coat apply to the intermediate coat and topcoat.

All coats shall be applied to achieve a smooth, uniform appearance that is free of dryspray, overspray, and orange peel. Shadow-through, pinholes, bubbles, skips, misses, lap marks between applications, runs, sags, or other visible discontinuities are unacceptable.

Masked off areas around field connections shall be coated in the field after the steel is fully erected according to the touch-up procedure for the completed system.

When the application of field coat(s) is required, the existing shop applied coats shall be prepared and field painting performed according to the applicable provisions of Article 506.10. If any coat has exceeded its recoat time, the surface shall be completely roughened or removed and replaced according to the manufacturer's instructions, prior to the application of the topcoat.

All coatings shall be applied by spray, supplemented with brushing or rolling, if needed. Special attention shall be given to obtaining complete coverage and proper coating thickness in crevices, on welds and edges, and in hard to reach areas.

**Application of Paint System over Galvanizing:** If galvanizing is used in lieu of metallizing and Paint System 1, no further painting is required. If galvanizing is used in lieu of metallizing and Paint System 2, apply a two-coat system consisting of a full waterborne acrylic intermediate coat and a full waterborne acrylic finish coat from System 2. If galvanizing is used in lieu of metallizing and Paint System 3, apply a full epoxy intermediate coat and a full urethane coat from System 3. To minimize handling and erection damage the acrylic coats of System 2 shall be applied in the field. Except as noted on the plans, the epoxy and urethane coats of System 3 can be applied in the shop or field.

**Touch-Up of Completed Coating System:** The Contractor shall repair all damaged and/or unacceptable areas of the completed coating system (all metallizing, galvanizing, and paint layers) prior to shipment as defined below. The same process shall be followed for the repair of shipping, handling, and erection damage.

Damage to the metallizing, galvanizing, and/or paint that does not expose the substrate shall be prepared by solvent cleaning in accordance with SSPC-SP 1 followed by power tool cleaning in accordance with SSPC-SP 3 to remove loose material. For the repair of damaged metallizing or galvanizing that exposes the substrate, the surface shall be spot blast cleaned in accordance with SSPC-SP 10. If blast cleaning cannot be performed, as authorized by the Engineer, the damage shall be spot power tool cleaned to SSPC-SP11.

The metallizing, galvanizing and/or paint surrounding each repair area shall be feathered for a distance of 1 to 2 inches (25 to 50 mm) to provide a smooth, tapered transition into the existing intact material. The surrounding intact paint shall be roughened to promote adhesion of the repair coats.



Damage to metallizing or galvanizing extends to the substrate shall be repaired. For metallizing it is critical that all remnants of sealer or paint have been removed from the porosity of the metallizing before applying new metallizing or an adhesion failure can occur. If it is no longer feasible to apply metallizing, spot-apply an organic zinc primer meeting the requirements of Section 1008. For galvanizing, spot apply organic zinc. After priming, for both the metallizing and galvanizing, apply the same intermediate and finish coats used on the surrounding steel. If the damage does not expose the substrate, only the effected paint coat(s) shall be applied.

**Surface Preparation and Painting of Galvanized Fasteners:** All ASTM A 325 or ASTM F 3125 high strength steel bolts, nuts and washers shall be hot dip galvanized according to AASHTO M232, except in areas where the metallized surfaces are to be top coated, in which case they shall be mechanically galvanized according to Article 1006.08(a) of the Standard Specifications.

The Contractor shall prepare all fasteners (i.e., galvanized nuts, bolts, etc.) by power tool cleaning in accordance with SSPC-SP 3. Following power tool cleaning and prior to painting, the surfaces shall be solvent cleaned according to SSPC-SP 1. Slight stains of torqueing compound dye may remain after cleaning provided the dye is not transferred to a cloth after vigorous rubbing. If any dye is transferred to a cloth after vigorous rubbing, additional cleaning is required.

Spot paint the fasteners with one coat of an aluminum epoxy mastic coating meeting the requirements of Article 1008.03 of the Standard Specifications.

**Shipping and Handling:** The Contractor shall take special care in handling the steel in the shop and when loading for shipment. Painted, metallized, or galvanized steel shall not be moved or handled until sufficient cure time has elapsed to prevent handling damage. During shipping, the steel shall be insulated from the moving apparatus (i.e., chains, cables, hooks, clamps, etc.) by softeners approved by the Engineer. Apparatus used to hoist the steel shall be padded. Steel shall be placed on wood dunnage and spaced in such a manner that no rubbing will occur during shipment that could damage the paint, metallizing or galvanizing.

**Special Instructions:** At the completion of the work, the Contractor shall stencil on the bridge, using a contrasting colored paint, the date of metallizing and painting. The letters shall be capitals, not less than 2 inches (50 mm) and not more than 3 inches (75 mm) in height. The information defined below shall be stenciled on the exterior face of the first girders at the bridge abutments (approximately 1 or 2 feet outward from the abutment end of the girders). The Engineer will identify the bridge member(s) to be stenciled.

When all coats are applied in the shop with the exception of touch-up, the shop Contractor shall do the stenciling. The stencil shall contain the following words on four lines: "METALLIZED BY" on the first line; name of the Contractor on the second line; and the month and year in which the coating was completed on the third line; and the applicable system Code on the fourth line.

When the finish coat is applied in the field, the Contractor shall do the stenciling as described above, but insert "PAINTED BY" and the Contractor's name after the fourth line.

**Basis of Payment:** This work shall not be paid for separately but shall be included in the unit price bid for furnishing and/or erecting structural steel according to Article 505.13.

## **Appendix 1 – Reference List**

The Shop and Field Contractor(s) shall maintain the following regulations and references on site for the duration of the project:

### **Illinois Environmental Protection Act**

#### **American Society of Testing Material**

- ASTM D 4285, Standard Test Method for Indicating Oil or Water in Compressed Air
- ASTM B833, Standard Specifications for Zinc Wire for Thermal Spraying (Metallizing)
- ASTM D4541, Standard Test Method for Pull-Off Strength of Coatings Using Portable Adhesion Testers

#### **Society of Protective Coatings**

- SSPC-AB 1, Mineral and Slag Abrasives
- SSPC-AB 2, Specification for Cleanliness of Recycled Ferrous Metallic Abrasives
- SSPC-AB 3, Newly Manufactured or Re-Manufactured Steel Abrasives
- SSPC-PA 2, Measurement of Dry Coating Thickness with Magnetic Gages
- SSPC-QP 1, Standard Procedure for Evaluating Painting Shop Contractors (Field Application to Complex Structures)
- SSPC-QP 2, Standard Procedure for Evaluating the Qualifications of Painting Shop Contractors to Remove Hazardous Paint
- SSPC-SP 1, Solvent Cleaning
- SSPC-SP 5/NACE No. 1, White Metal Blast Cleaning
- SSPC-SP 11, Power Tool Cleaning to Bare Metal
- SSPC-SP 12/NACE No. 5, Surface Preparation and Cleaning of Metals by Water Jetting Prior to Recoating
- SSPC-SP 16, Brush-Off Blast Cleaning of Coated and Uncoated Galvanized Steel, Stainless Steels, and Non-Ferrous Metals

- SSPC-PA 17, Procedure for Determining Conformance to Steel Profile/Surface Roughness/Peak Count Requirements.
- SSPC-VIS 1, Guide and Reference Photographs for Steel Surfaces Prepared by Dry Abrasive Blast Cleaning
- SSPC-VIS 5, Guide and Reference Photographs for Steel Prepared by Wet Abrasive Blast Cleaning
- SSPC-Guide 15, Field Methods for Retrieval and Analysis of Soluble Salts on Steel and Other Nonporous Surfaces
- SSPC-CS 23.00/AWS C2.23M/NACE No. 12, Specification for the Application of Thermal Spray Coatings (Metallizing) of Aluminum, Zinc, and Their Alloys and Composites for the Corrosion Protection of Steel

**American National Standards Institute/American Welding Society**

- ANSI/AWS C2.25/C2.25M, Specification for Solid and Composite Wires, and Ceramic Rods for Thermal Spraying
- AWS C2.6/C2.6M, Guide for Thermal-Spray Operator Qualification

Metallizing wire and coating manufacturer's application instructions, MSDS and product data sheets

**DRILLED SHAFTS**

Effective: October 5, 2015

Revised: October 27, 2023

Revise Section 516 of the Standard Specifications to read:

**“SECTION 516. DRILLED SHAFTS**

**516.01 Description.** This work shall consist of constructing drilled shaft foundations.

**516.02 Materials.** Materials shall be according to the following.

Item	Article/Section
(a) Portland Cement Concrete (Note 1) .....	1020
(b) Reinforcement Bars.....	1006.10
(c) Grout (Note 2).....	1024.01
(d) Permanent Steel Casing.....	1006.05(d)
(e) Slurry (Note 3)	

Note 1. When the soil contains sulfate contaminates, ASTM C 1580 testing will be performed to assess the severity of sulfate exposure to the concrete. If the sulfate contaminate is >0.10 to < 0.20 percent by mass, a Type II (MH) cement shall be used. If the sulfate contaminate is >0.20 to < 2.0 percent by mass, a Type V cement shall be used. If the sulfate contaminate is  $\geq$  2.0 percent by mass, refer to ACI 201.2R for guidance.

Note 2. The sand-cement grout mix shall be according to Section 1020 and shall be two to five parts sand and one part Type I or II cement. The maximum water cement ratio shall be sufficient to provide a flowable mixture with a typical slump of 10 in. (250 mm).

Note 3. Slurry shall be bentonite, emulsified polymer, or dry polymer, and shall be approved by the Engineer.

**516.03 Equipment.** Equipment shall be according to the following.

Item	Article/Section
(a) Concrete Equipment	1020.03
(b) Drilling Equipment (Note 1)	
(c) Hand Vibrator	1103.17(a)
(d) Underwater Concrete Placement Equipment	1103.18

Note 1. The drilling equipment shall have adequate capacity, including power, torque and down thrust, to create a shaft excavation of the maximum diameter specified to a depth of 20 percent beyond the depths shown on the plans.

**516.04 Submittals.** The following information shall be submitted on form BBS 133.

- (a) Qualifications. At the time of the preconstruction conference, the Contractor shall provide the following documentation.
- (1) References. A list containing at least three projects completed within the three years prior to this project's bid date which the Contractor performing this work has installed drilled shafts of similar diameter, length, and site conditions to those shown in the plans. The list of projects shall contain names and phone numbers of owner's representatives who can verify the Contractor's participation on those projects.
  - (2) Experience. Name and experience record of the drilled shaft supervisor, responsible for all facets of the shaft installation, and the drill operator(s) who will be assigned to this project. The supervisor and operator(s) shall each have a minimum of three years experience in the construction of drilled shafts.
- (b) Installation Procedure. A detailed installation procedure shall be submitted to the Engineer for acceptance at least 28 days prior to drilled shaft construction and shall address each of the following items unless otherwise directed by the Engineer in writing.
- (1) Equipment List. List of proposed equipment to be used including cranes, drill rigs, augers, belling tools, casing, vibratory hammers, core barrels, bailing buckets, final cleaning equipment, slurry equipment, tremies, or concrete pumps, etc.
  - (2) General Sequence. Details of the overall construction operation sequence, equipment access, and the sequence of individual shaft construction within each substructure bent or footing group. The submittal shall address the Contractor's proposed time delay and/or the minimum concrete strength necessary before initiating a shaft excavation adjacent to a recently installed drilled shaft.

- (3) Shaft Excavation. A site specific step by step description of how the Contractor anticipates the shaft excavation to be advanced based on their evaluation of the subsurface data and conditions expected to be encountered. This sequence shall note the method of casing advancement, anticipated casing lengths, tip elevations and diameters, the excavation tools used and drilled diameters created. The Contractor shall indicate whether wet or dry drilling conditions are expected and if groundwater will be sealed from the excavation.
- (4) Slurry. When the use of slurry is proposed, details on the types of additives to be used and their manufacturers shall be provided. In addition, details covering the measurement and control of the hardness of the mixing water, agitation, circulation, de-sanding, sampling, testing, and chemical properties of the slurry shall be submitted.
- (5) Shaft Cleaning. Method(s) and sequence proposed for the shaft cleaning operation.
- (6) Reinforcement Cage and Permanent Casing. Details of reinforcement placement including rolling spacers to be used and method to maintain proper elevation and location of the reinforcement cage within the shaft excavation during concrete placement. The method(s) of adjusting the reinforcement cage length and permanent casing if rock is encountered at an elevation other than as shown on the plans. As an option, the Contractor may perform soil borings and rock cores at the drilled shaft locations to determine the required reinforcement cage and permanent casing lengths.
- (7) Concrete Placement. Details of concrete placement including proposed operational procedures for free fall, tremie or pumping methods. The sequence and method of casing removal shall also be stated along with the top of pour elevation, and method of forming through water above streambed.
- (8) Mix Design. The proposed concrete mix design(s).
- (9) Disposal Plan. Containment and disposal plan for slurry and displaced water. Containment and disposal plan for contaminated concrete pushed out of the top of the shaft by uncontaminated concrete during concrete placement.
- (10) Access and Site Protection Plan. Details of access to the drilled shafts and safety measures proposed. This shall include a list of casing, scaffolding, work platforms, temporary walkways, railings, and other items needed to provide safe access to the drilled shafts. Provisions to protect open excavations during non-working hours shall be included.

The Engineer will evaluate the drilled shaft installation procedure and notify the Contractor of acceptance, need for additional information, or concerns with the installation's effect on the existing or proposed structure(s).

## CONSTRUCTION REQUIREMENTS

**516.05 General.** Excavation for drilled shaft(s) shall not proceed until written authorization is received from the Engineer. The Contractor shall be responsible for verification of the dimensions and alignment of each shaft excavation as directed by the Engineer.

Unless otherwise approved in the Contractor's installation procedure, no shaft excavation, casing installation, or casing removal with a vibratory hammer shall be made within four shaft diameters center to center of a shaft with concrete that has a compressive strength less than 1500 psi (10,300 kPa). The site-specific soil strengths and installation methods selected will determine the actual required minimum spacing, if any, to address vibration and blow out concerns.

Lost tools shall not remain in the shaft excavation without the approval of the Engineer.

Blasting shall not be used as a method of shaft excavation.

**516.06 Shaft Excavation Protection Methods.** The construction of drilled shafts may involve the use of one or more of the following methods to support the excavation during the various phases of shaft excavation, cleaning, and concrete placement dependent on the site conditions encountered. Surface water shall not flow uncontrolled into the shaft excavation, however water may be placed into the shaft excavation in order to meet head pressure requirements according to Articles 516.06(c) and 516.13.

The following are general descriptions indicating the conditions when these methods may be used.

(a) **Dry Method.** The dry construction method shall only be used at sites where the groundwater and soil conditions are suitable to permit the drilling and dewatering of the excavation without causing subsidence of adjacent ground, boiling of the base soils, squeezing, or caving of the shaft side walls. The dry method shall consist of drilling the shaft excavation, removing accumulated water, cleaning the shaft base, and placing the reinforcement cage and concrete in a predominately dry excavation.

**Slurry Method.** The slurry construction method may be used at sites where dewatering the excavation would cause collapse of the shaft sidewalls or when the volume and head of water flowing into the shaft is likely to contaminate the concrete during placement resulting in a shaft defect. This method uses slurry, or in rare cases water, to maintain stability of the shaft sidewall while advancing the shaft excavation. After the shaft excavation is completed, the slurry level in the shaft shall be kept at an elevation to maintain stability of the shaft sidewall, maintain stability of the shaft base, and prevent additional groundwater from entering the shaft. The shaft base shall be cleaned, the reinforcement cage shall be set, and the concrete shall be discharged at the bottom of the shaft excavation, displacing the slurry upwards.

- (b) Temporary Casing Method. Temporary casing shall be used when either the dry or slurry methods provide inadequate support to prevent sidewall caving or excessive deformation of the shaft excavation. Temporary casing may be used with slurry or be used to reduce the flow of water into the excavation to allow dewatering and concrete placement in a dry shaft excavation. Temporary casing shall not be allowed to remain permanently without the approval of the Engineer.

During removal of the temporary casing, the level of concrete in the casing shall be maintained at a level such that the head pressure inside the casing is a minimum of 1.25 times the head pressure outside the casing, but in no case is less than 5 ft (1.5 m) above the bottom of the casing. Casing removal shall be at a slow, uniform rate with the pull in line with the shaft axis. Excessive rotation of the casing shall be avoided to limit deformation of the reinforcement cage. In addition, the slump requirements during casing removal shall be according to Article 516.12.

When called for on the plans, the Contractor shall install a permanent casing as specified. Permanent casing may be used as a shaft excavation support method or may be installed after shaft excavation is completed using one of the above methods. After construction, if voids are present between the permanent casing and the drilled excavation, the voids shall be filled with grout by means of tremie(s) or concrete pump which shall be lowered to the bottom of the excavation. The contractor's means and methods for grout placement shall fill the annular void(s) between the permanent casing and the surrounding earth material to restore and provide lateral earth resistance to the shaft. Grout yield checks shall be performed by the contractor for submittal to the Engineer. Permanent casing shall not remain in place beyond the limits shown on the plans without the specific approval of the Engineer.

When the shaft extends above the streambed through a body of water and permanent casing is not shown, the portion above the streambed shall be formed with removable casings, column forms, or other forming systems as approved by the Engineer. The forming system shall not scar or spall the finished concrete or leave in place any forms or casing within the removable form limits as shown on the plans unless approved as part of the installation procedure. The forming system shall not be removed until the concrete has attained a minimum compressive strength of 2500 psi (17,200 kPa) and cured for a minimum of 72 hours. For shafts extending through water, the concrete shall be protected from water action after placement for a minimum of seven days.

**516.07 Slurry.** When slurry is used, the Contractor shall provide a technical representative of the slurry additive manufacturer at the site prior to introduction of the slurry into the first shaft where slurry will be used, and during drilling and completion of a minimum of one shaft to adjust the slurry mix to the specific site conditions. During construction, the level of the slurry shall be maintained a minimum of 5 feet (1.5 m) above the height required to prevent caving of the shaft excavation. In the event of a sudden or significant loss of slurry in the shaft excavation, the construction of that foundation shall be stopped and the shaft excavation backfilled or supported by temporary casing, until a method to stop slurry loss, or an alternate construction procedure, has been approved by the Engineer.



- (a) General Properties. The material used to make the slurry shall not be detrimental to the concrete or surrounding ground. Mineral slurries shall have both a mineral grain size that remains in suspension and sufficient viscosity and gel characteristics to transport excavated material to a suitable screening system. Polymer slurries shall have sufficient viscosity and gel characteristics to transport excavated material to suitable screening systems or settling tanks. The percentage and specific gravity of the material used to make the slurry shall be sufficient to maintain the stability of the excavation and to allow proper concrete placement.

If approved by the Engineer, the Contractor may use water and excavated soils as drilling slurry. In this case, the range of acceptable values for density, viscosity and pH, as shown in the following table for bentonite slurry shall be met.

When water is used as the slurry to construct rock sockets in limestone, dolomite, sandstone or other formations that are not erodible, the requirements for slurry testing shall not apply if the entire fluid column is replaced with fresh water after drilling. To do so, fresh water shall be introduced at the top of the shaft excavation and existing water used during drilling shall be pumped out of the shaft excavation from the bottom of the shaft excavation until the entire volume of fluid has been replaced.

- (b) Preparation. Prior to introduction into the shaft excavation, the manufactured slurry admixture shall be pre-mixed thoroughly with clean, fresh water and for adequate time in accordance with the slurry admixture manufacturer's recommendations. Slurry tanks of adequate capacity shall be used for slurry mixing, circulation, storage and treatment. No excavated slurry pits will be allowed in lieu of slurry tanks without approval from the Engineer. Adequate desanding equipment shall be provided to control slurry properties during the drilled shaft excavation in accordance with the values provided in Table 1.
- (c) Quality Control. Quality control tests shall be performed on the slurry to determine density, viscosity, sand content and pH of freshly mixed slurry, recycled slurry and slurry in the shaft excavation. Tests of slurry samples from within two feet of the bottom and at mid-height of the shaft excavation shall be conducted in each shaft excavation during the excavation process to measure the consistency of the slurry. A minimum of four sets of tests shall be conducted during the first eight hours of slurry use on the project. When a series of four test results do not change more than 1% from the initial test, the testing frequency may be decreased to one set every four hours of slurry use. Reports of all tests, signed by an authorized representative of the Contractor, shall be furnished to the Engineer upon completion of each drilled shaft. The physical properties of the slurry shall be as shown in Table 1.

The slurry shall be sampled and tested less than 1 hour before concrete placement. Any heavily contaminated slurry that has accumulated at the bottom of the shaft shall be removed. The contractor shall perform final shaft bottom cleaning after suspended solids have settled from the slurry. Concrete shall not be placed if the slurry does not have the required physical properties.

Table 1 – SLURRY PROPERTIES				
	Bentonite	Emulsified Polymer	Dry Polymer	Test Method
Density, lb/cu ft (kg/cu m) (at introduction)	65.2 ± 1.6 <sup>1</sup> (1043.5 ± 25.6)	63 (1009.0) max.	63 (1009.0) max.	ASTM D 4380
Density, lb/cu ft (kg/cu m) (prior to concrete placement)	67.0 ± 3.5 <sup>1</sup> (1073.0 ± 56.0)	63 (1009.0) max.	63 (1009.0) max.	ASTM D 4380
Viscosity <sup>2</sup> , sec/qt (sec/L)	46 ± 14 (48 ± 14)	38 ± 5 (40 ± 5)	65 ± 15 (69 ± 16)	ASTM D 6910
pH	9.0 ± 1.0	9.5 ± 1.5	9.0 ± 2.0	ASTM D 4972
Sand Content, percent by volume (at introduction)	4 max.	1 max.	1 max.	ASTM D 4381
Sand Content, percent by volume (prior to concrete placement)	10 max.	1 max.	1 max.	ASTM D 4381
Contact Time <sup>3</sup> , hours	4 max.	72 max.	72 max.	

Note 1. When the slurry consists of only water and excavated soils, the density shall not exceed 70 lb/cu ft (1121 kg/cu m).

Note 2. Higher viscosities may be required in loose or gravelly sand deposits.

Note 3. Contact time is the time without agitation and sidewall cleaning.

**516.08 Obstructions.** An obstruction is an unknown isolated object that causes the shaft excavation method to experience a significant decrease in the actual production rate and requires the Contractor to core, break up, push aside, or use other means to mitigate the obstruction. Subsurface conditions such as boulders, cobbles, or logs and buried infrastructure such as footings, piling, or abandoned utilities, when shown on the plans, shall not constitute an obstruction. When an obstruction is encountered, the Contractor shall notify the Engineer immediately and upon concurrence of the Engineer, the Contractor shall mitigate the obstruction with an approved method.

**516.09 Top of Rock.** The top of rock will be considered as the point where rock, defined as bedded deposits and conglomerate deposits exhibiting the physical characteristics and difficulty of rock removal as determined by the Engineer, is encountered which cannot be drilled with augers and/or underreaming tools configured to be effective in the soils indicated in the contract documents.

**516.10 Design Modifications.** If the top of rock elevation differs from that shown on the plans by more than 10 percent of the length of the drilled shaft above the rock, the Engineer shall be contacted to determine if any drilled shaft design changes may be required. In addition, if the type of soil or rock encountered is not similar to that shown in the subsurface exploration data, the Contractor may be required to extend the drilled shaft length(s) beyond those specified in the plans. In either case, the Engineer will determine if revisions are necessary and the extent of the modifications required.

**516.11 Excavation Cleaning and Inspection.** Materials removed or generated from the shaft excavations shall be disposed of according to Article 202.03.

After excavation, each shaft shall be cleaned. For a drilled shaft terminating in soil, the depth of sediment or debris shall be a maximum of 1 1/2 in. (38 mm). For a drilled shaft terminating in rock, the depth of sediment or debris shall be a maximum of 1/2 in. (13 mm).

A shaft excavation shall be overreamed when, in the opinion of the Engineer, the sidewall has softened, swelled, or has a buildup of slurry cake. Overreaming may also be required to correct a shaft excavation which has been drilled out of tolerance. Overreaming may be accomplished with a grooving tool, overreaming bucket, or other approved equipment. Overreaming thickness shall be a minimum of 1/2 in. (13 mm) and a maximum of 3 in. (75 mm).

**516.12 Reinforcement.** This work shall be according to Section 508 and the following.

The shaft excavation shall be cleaned and inspected prior to placing the reinforcement cage. The reinforcement cage shall be completely assembled prior to drilling and be ready for adjustment in length as required by the conditions encountered. The reinforcement cage shall be lifted using multiple point sling straps or other approved methods to avoid reinforcement cage distortion or stress. Cross frame stiffeners may be required for lifting or to keep the reinforcement cage in proper position during lifting and concrete placement.

The Contractor shall attach rolling spacers to keep the reinforcement cage centered within the shaft excavation during concrete placement and to ensure that at no point will the finished shaft have less than the minimum concrete cover(s) shown on the plans. The rolling spacers or other approved non-corrosive spacing devices shall be installed within 2 ft (0.6 m) of both the top and bottom of the drilled shaft and at intervals not exceeding 10 ft (3 m) throughout the length of the shaft to ensure proper reinforcement cage alignment and clearance for the entire shaft. The number of rolling spacers at each level shall be one for each 1.0 ft (300 mm) of shaft diameter, with a minimum of four rolling spacers at each level. For shafts with different shaft diameters throughout the length of the excavation, different sized rolling spacers shall be provided to ensure the reinforcement cage is properly positioned throughout the entire length of the shaft.

When a specific concrete cover between the base of the drilled shaft and the reinforcement cage is shown on the plans, the bottom of the reinforcement cage shall be supported so that the proper concrete cover is maintained.

If the conditions differ such that the length of the shaft is increased, additional longitudinal bars shall be either mechanically spliced or lap spliced to the lower end of the reinforcement cage and confined with either hoop ties or spirals. The Contractor shall have additional reinforcement available or fabricate the reinforcement cages with additional length as necessary to make the required adjustments in a timely manner as dictated by the encountered conditions. The additional reinforcement may be non-epoxy coated.

**516.13 Concrete Placement.** Concrete work shall be performed according to the following.

Throughout concrete placement the head pressure inside the drilled shaft shall be at least

1.1 times the head pressure outside the drilled shaft.

Concrete placement shall begin within 1 hour of shaft cleaning and inspection. The pour shall be made in a continuous manner from the bottom to the top elevation of the shaft as shown on the contract plan or as approved in the Contractor's installation procedure. Concrete placement shall continue after the shaft excavation is full and until 18 in. (450 mm) of good quality, uncontaminated concrete is expelled at the top of shaft. Vibration of the concrete will not be allowed when the concrete is displacing slurry or water. In dry excavations, the concrete in the top 10 ft (3 m) of the shaft shall be vibrated.

When using temporary casing or placing concrete under water or slurry, a minimum of seven days prior to concrete placement, a 4 cu yd (3 cu m) trial batch of the concrete mixture shall be performed to evaluate slump retention. Temporary casing shall be withdrawn before the slump of the concrete drops below 6 in. (150 mm). For concrete placed using the slurry method of construction, the slump of all concrete placed shall be a minimum of 6 in. (150 mm) at the end of concrete placement.

Devices used to place concrete shall have no aluminum parts in contact with concrete.

When the top of the shaft is at the finished elevation and no further concrete placement above the finished elevation is specified, the top of the shaft shall be level and finished according to Article 503.15(a).

Concrete shall be placed by free fall, tremie, or concrete pump subject to the following conditions.

- (a) Free Fall Placement. Concrete shall only be placed by free fall when the rate of water infiltration into the shaft excavation is less than 12 in. (300 mm) per hour and the depth of water in the shaft excavation is less than 3 in. (75 mm) at the time of concrete placement.

Concrete placed by free fall shall fall directly to the base without contacting the reinforcement cage, cross frame stiffeners, or shaft sidewall. Drop chutes may be used to direct concrete to the base during free fall placement.

Drop chutes used to direct placement of free fall concrete shall consist of a smooth tube. Concrete may be placed through either a hopper at the top of the tube or side openings as the drop chute is retrieved during concrete placement. The drop chute shall be supported so that free fall does not exceed 60 ft (18.3 m) for conventional concrete or 30 ft (9.1 m) for self-consolidating concrete. If placement cannot be satisfactorily accomplished by free fall in the opinion of the Engineer, either a tremie or pump shall be used to accomplish the pour.

- (b) Tremie and Concrete Pump Placement. Concrete placement shall be according to Article 503.08, except the discharge end of the steel pipe shall remain embedded in the concrete a minimum of 10 ft (3.0 m) throughout concrete placement when displacing slurry or water.

**516.14 Construction Tolerances.** The following construction tolerances shall apply to all drilled shafts.

- (a) Center of Shaft. The center of the drilled shaft shall be within 3 in. (75 mm) of the plan station and offset at the top of the shaft.
- (b) Center of Reinforcement Cage. The center of the reinforcement cage shall be within 1 1/2 in. (40 mm) of plan station and offset at the top of the shaft.
- (c) Vertical Plumbness of Shaft. The out of vertical plumbness of the shaft shall not exceed 1.5 percent.

- (d) Vertical Plumbness of Reinforcement Cage. The out of vertical plumbness of the shaft reinforcement cage shall not exceed 0.83 percent.
- (e) Top of Shaft. The top of the shaft shall be no more than 1 in. (25 mm) above and no more than 3 in. (75 mm) below the plan elevation.
- (f) Top of Reinforcement Cage. The top of the reinforcement cage shall be no more than 1 in. (25 mm) above and no more than 3 in. (75 mm) below the plan elevation.
- (g) Bottom of shaft. Excavation equipment and methods used to complete the shaft excavation shall have a nearly planar bottom. The cutting edges of excavation equipment used to create the bottom of shafts in rock shall be normal to the vertical axis of the shaft within a tolerance of 6.25 percent.

**516.15 Method of Measurement.** This work will be measured for payment in place and the volume computed in cubic yards (cubic meters). The volume will be computed using the plan diameter of the shaft multiplied by the measured length of the shaft. The length of shaft in soil will be computed as the difference in elevation between the top of the drilled shaft shown on the plans, or as installed as part of the Contractor's installation procedure, and the bottom of the shaft or the top of rock (when present) whichever is higher. The length of shaft in rock will be computed as the difference in elevation between the measured top of rock and the bottom of the shaft.

When permanent casing is specified, it will be measured for payment in place, in feet (meters). Permanent casing installed at the Contractor's option will not be measured for payment.

Reinforcement furnished and installed will be measured for payment according to Article 508.07.

**516.16 Basis of Payment.** This work will be paid for at the contract unit price per cubic yard (cubic meter) for DRILLED SHAFT IN SOIL, and/or DRILLED SHAFT IN ROCK.

Permanent casing will be paid for at the contract unit price per foot (meter) for PERMANENT CASING.

Reinforcement furnished and installed will be paid for according to Article 508.08.

Obstruction mitigation will be paid for according to Article 109.04."

## **PREFORMED PAVEMENT JOINT SEAL**

Effective: October 4, 2016

Revised: March 24, 2023

Description. This work shall consist of furnishing all labor, equipment and materials necessary to prepare the joint opening and install pavement joint seal(s) at the locations specified. Unless otherwise detailed on the plans, the joint shall be sized for a rated movement of 2 inches (50 mm).

Materials: Unless otherwise specified, one of the following prefabricated joint seals will be permitted.

- (a) Preformed Elastomeric Joint Seal. This material shall be according to Section 1053.01.
- (b) Preformed Pre-compressed, Silicone Coated, Self-Expanding Sealant System. This Sealant system shall be comprised of three components: 1) cellular polyurethane foam impregnated with hydrophobic 100% acrylic, water-based emulsion, factory coated with highway-grade, fuel resistant silicone; 2) field-applied epoxy adhesive primer, 3) field-injected silicone sealant bands.

The preformed, pre-compressed silicone joint seal shall, as a minimum, be according to the following:

- The joint seal shall be held in place by a non-sag, high modulus silicone adhesive.
- The joint seal shall be compatible with the epoxy and header material.
- The joint seal shall withstand the effects of vertical and lateral movements, skew movements and rotational movement without adhesive or cohesive failure.
- The joint seal shall be designed so that, the material is capable of movement of +50%, -50% (100% total) of nominal material size.
- The gland shall not contain any open, unsealed joints along its length in its final condition.
- Changes in plane and direction shall be executed using factory fabricated 90 degree transition assemblies. The transitions shall be watertight at the inside and outside corners through the full movement of the product.
- The depth of the joint shall be recessed 3/4 in. (19 mm) below the riding surface throughout the normal limits of joint movement.
- The joint seal shall be resistant to ultraviolet rays.
- The joint seal shall be resistant to abrasion, oxidation, oils, gasoline, salt, and other materials that may be spilled on or applied to the surface.
- The manufacturer shall certify that the joint composition shall be free of any waxes or wax compounds; asphalts or asphalt compounds.

The joint material shall meet the following physical properties:

<b>Property</b>	<b>Requirement</b>	<b>Test Method</b>
Tensile Strength of Silicone Coating (min)	140 psi	ASTM D 412
UV Resistance of Joint System	No Changes--2000 Hours	ASTM C793
Density of Cellular Polyurethane Foam	4.0 lb/ cu ft (200kg/cu m)	ASTM D545
Heat Aging Effects (Silicone Coating)	No cracking, chalking	ASTM C 792
Joint System Operating temp range (min)	-40° F to 185° F	ASTM C 711

The adhesive shall be a two-component, 100% solid, modified epoxy meeting the requirements of ASTM C881, Type I, Grade 3, Class B & C. The adhesive shall also have the following properties:

<b>Property</b>	<b>Requirement</b>	<b>Test method</b>
Tensile Strength	2,500 psi (24 MPa) min.	ASTM D638
Compressive Strength	7000 psi (48 MPa) min.	ASTM D695
Bond Strength (Dry Cure)	2000 psi (28MPa) min	ASTM C882
Water Absorption	0.1% by weight	ASTM D570



The silicone band adhesive shall have the following properties:

<b>Property</b>	<b>Requirement</b>	<b>Test Method</b>
Movement Capability	+50/-50%	ASTM C 719
Elongation at Break	>600%	ASTM D 5893
Slump	≤0.3"	ASTM D 2202
Hardness (Shore A) max.	20	ASTM C 661
Tack free time (max)	60 minutes	ASTM C 679
Heat Aging Effects	No cracking, chalking	ASTM C 792
Resilience	≥ 75%	ASTM D5329
Bond	0% Adhesive or Cohesive Failure after 5 cycles @100%extension	ASTM D 5329

- (c) Performed Silicone Joint Seal. The preformed silicone joint seal used for this item shall conform to the following specifications:

**Table 1**  
**Physical Properties of Preformed Silicone Gland**

<b>Property</b>	<b>Requirement</b>	<b>Test Method</b>
Rated Movement Capability	+2 ¼ inch total	N/A
Tensile Strength, psi.	1000 min	ASTM D 412
Elongation	400% min	ASTM D 412
Tear (die B)	100 ppi. min	ASTM D 624
Hardness Durometer (Shore A).	55 +/- 5 max	ASTM D 2240
Compression set at 212°F, 70 hrs	30% max	ASTM D 395
Heat Aged Properties	5pt max loss on Durometer	ASTM D 573
Tensile and Elongation % Loss	10 % max	

The color of the preformed silicone seal shall be black, made by the addition of Carbon Black fillers which increases UV resistance, tensile strength, and abrasion wear properties.

The locking adhesive shall be non-sag, high modulus silicone adhesive conforming to the following specifications:

**Table 2  
 Physical Properties of the Silicone Locking Adhesive**

<b>Property</b>	<b>Requirement</b>	<b>Test Method</b>
Tensile Strength, psi.	200 min	ASTM D 412
Elongation, %	450 min	ASTM D 412
Tack Free Time, minutes.	20 max.	ASTM C 679
Cure Time ¼" bead, hrs	24 max	ASTM C 679
Resistance to U.V.	No cracking, chalking, or degradation	ASTM C793
VOC (g/L)	0	ASTM D 3960

Any rips, tears, or bond failure will be cause for rejection.

The two part epoxy primer shall be supplied for application to the vertical faces of the joint opening. The supplied primer shall be equally as effective when bonded to concrete or steel. This primer shall meet the following criteria:

**Table 3  
 Physical Properties of Preformed Silicone Joint System Primer**

<b>Property</b>	<b>Requirement</b>	<b>Test Method</b>
Viscosity (cps)	44	ASTM D 2196
Color	Light Amber	Visual
Solids (%)	41	ASTM D 4209
Specific Gravity	0.92	ASTM D 1217
Product Flash Point (°F, T.C.C.)	48	ASTM D 56
Package Stability	N/A	One year in tightly sealed containers
Cleaning	N/A	Mineral Spirits
VOC (g/L)	520	ASTM D 3960

- (d) Preformed Inverted EPDM Joint Seal. The preformed inverted EPDM joint seal used for this item shall conform to the following specifications:

**Table 1**  
**Physical Properties of Preformed Silicone Gland**

Property	Requirement	Test Method
Rated Movement Capability	Up To 5 inch total	N/A
Tensile Strength, psi.	1200 psi min	ASTM D 412
Elongation	400 % min	ASTM D 412
Tear (Die C)	150 pli. min	ASTM D 624
Durometer Content	50 +/- 5 max	ASTM D 2240
Water Resistance (70 hrs @ 100c)	10% max	ASTM D 471
Ozone Resistance	100 min	ASTM D 1171

**Table 2**  
**Physical Properties of the V-Epoxy-R**

V-Epoxy-R adhesive meets the requirements of ASTM C881 Type III, Grade 2. The adhesive shall also have the following properties:

Property	Requirement	Test Method
Color	Gray	Visual
Viscosity	45,000 CP (typ.)	N/A
Gel Time (minutes)	30 min.	ASTM C 881
Shelf Life (Separate Sealed Containers)	12 Months	N/A
Resistance to U.V.	No cracking, chalking, or degradation	ASTM C793
VOC (g/L)	0	ASTM D 3960

Any rips, tears, or bond failure will be cause for rejection.

- (e) Bonded Preformed Joint Seal. This joint system shall consist of preformed elastomeric seal bonded to the side walls of the joint opening using an adhesive as specified by the Manufacturer of the joint seal.

The bonded preformed joint seal shall be according to Table 1 of ASTM D2628 with the following exceptions: Compression set shall not be over 40 percent when tested according to Method B (Modified) of ASTM D 395 after 70 hours at 212 °F (100 °C). The Compression-Deflection requirement will not apply to the bonded preformed joint seal.

The adhesive shall be epoxy base, dual component, which resists salt, diluted acids, alkalis, solvents, greases, oils, moisture, sunlight and weathering. Temperatures up to 200 °F (93 °C) shall not reduce bond strength. At 68 °F (20 °C), the bond strength shall be a minimum of 1000 psi (6.9 MPa) within 24 hours.

Any primers or cleaning solutions used on the faces of the joint or on the profile of the sides of the bonded preformed joint seal shall be supplied by the manufacturer of the bonded preformed joint seal.

Any additional installation materials and adhesive for splicing joint sections shall be as supplied by the manufacturer of the preformed joint seal.

The Contractor shall submit the Manufacturer's material certification documentation stating that their materials meet the applicable requirements of this specification for the joint seal(s) installed.

## **CONSTRUCTION REQUIREMENTS**

General. The Contractor shall furnish the Engineer with the manufacturer's product information and installation procedures at least two weeks prior to installation.

The minimum ambient air temperature in which the joint seal can be installed is 40° F (4.4° C) and rising, except for bonded preformed joint seals which shall not be installed when temperatures below 50 °F (10 °C) are predicted within a 48 hour period.

The joint surface shall be completely dry before installing the Joint Seal. For newly placed concrete, the concrete shall be fully cured and allowed to dry out a minimum of seven additional days prior to placement of the seal. Cold, wet, inclement weather will require an extended drying time.

The Joint Seal shall not be installed immediately after precipitation or if precipitation is forecasted for the day. Joint preparation and installation of Joint Seal shall be done during the same day.

Surface Preparation. Surface preparation shall be according to the joint seal manufacturer's written instructions.

After surface preparation is completed, the joint shall be cleaned of debris using compressed air with a minimum pressure of 90 psi (620 kPa). The air compressor shall be equipped with traps to prevent the inclusion of water and/or oil in the air line. The compressed air shall be according to the cleanliness requirements of ASTM D 4285.

When priming is required per the manufacturer's instruction, this operation shall immediately follow cleaning.

Joint Installation. The Joint installation shall be per the manufacturer's instructions; special attention shall be given to ensure the joint seal is properly recessed below the top of the riding surface as recommended by the manufacturer.

For bonded joint seals the seal shall be inserted into the joint and held tightly against both sides of the joint until sufficient bond strength has been developed to resist the expected expansion forces.

Opening to traffic. As these joint systems are supposed to be recessed below the top of the riding surface, there should be no restriction, based on the joint seal installation, on when these joints can be reopened to traffic.

Method of Measurement. The installed prefabricated joint seal will not be measured for payment.

Basis of Payment. The prefabricated joint seal will not be paid for separately but shall be considered included in the cost of the adjacent concrete work involved.

**BAR SPLICERS, HEADED REINFORCEMENT**

Effective: September 2, 2022

Revised: October 27, 2023

Add the following to Article 508.08(b):

When bar splicers are epoxy-coated, all damaged or uncoated areas near the threaded ends shall be coated with a two-part epoxy according to ASTM D 3963 (D 3963M). All threaded ends of Stage II construction threaded splicer bars shall be coated according to ASTM D 3963 or dipped in an epoxy-mastic primer prior to joining the Stage II construction threaded splicer bar to the threaded coupler.

Add the following Article 508.02 (d)

Bar Terminators ..... 1006.10(a)(1)h

Add the following paragraph after Article 508.08 (c):

Bar terminators are threaded, headed attachments to reinforcement to form headed reinforcement. When specified on the plans, a bar terminator shall be attached to the designated reinforcement for development.

Add the following 4<sup>th</sup> paragraph to Article 508.11:

Bar Terminators will be paid for at the contract unit price per each for BAR TERMINATORS.

Add the following to Article 1006.10(a)(1)g:

For bar splicers with welded connections between the threaded coupler and threaded rod, the Stage I construction threaded splicer bar shall be welded to the threaded coupler using an all-around fillet weld.

Add the following Article 1006.10(a)(1)h:

Bar Terminators. Designated bars shall use a bar terminator to form headed reinforcement. Headed reinforcement shall conform to ASTM A970 with threaded attachment; Class HA; and reinforcement bars conforming to ASTM A706, except the connection strength of the bar terminator to the reinforcement bar shall meet, in tension, at least 125 percent of the specified yield strength of the reinforcement bar. The bar terminator shall be on the Department's qualified product list.

When the reinforcement bar to receive the bar terminator is epoxy coated, the bar terminator shall also be epoxy coated according to ASTM A 775 (A 775M)

**AGGREGATE SUBGRADE IMPROVEMENT (BDE)**

Effective: April 1, 2012

Revised: April 1, 2022

Add the following Section to the Standard Specifications:

**“SECTION 303. AGGREGATE SUBGRADE IMPROVEMENT**

**303.01 Description.** This work shall consist of constructing an aggregate subgrade improvement (ASI).

**303.02 Materials.** Materials shall be according to the following.

Item	Article/Section
(a) Coarse Aggregate .....	1004.07
(b) Reclaimed Asphalt Pavement (RAP) .....	1031.09

**303.03 Equipment.** The vibratory roller shall be according to Article 1101.01, or as approved by the Engineer. Vibratory machines, such as tampers, shall be used in areas where rollers do not fit.

**303.04 Soil Preparation.** The minimum immediate bearing value (IBV) of the soil below the improved subgrade shall be according to the Department’s “Subgrade Stability Manual” for the aggregate thickness specified.

**303.05 Placing and Compacting.** The maximum nominal lift thickness of aggregate gradations CA 2, CA 6, and CA 10 when compacted shall be 9 in. (225 mm). The maximum nominal lift thickness of aggregate gradations CS 1, CS 2, and RR 1 when compacted shall be 24 in. (600 mm).

The top surface of the aggregate subgrade improvement shall consist of a layer of capping aggregate gradations CA 6 or CA 10 that is 3 in. (75 mm) thick after compaction. Capping aggregate will not be required when aggregate subgrade improvement is used as a cubic yard pay item for undercut applications.

Each lift of aggregate shall be compacted to the satisfaction of the Engineer. If the moisture content of the material is such that compaction cannot be obtained, sufficient water shall be added so that satisfactory compaction can be obtained.

**303.06 Finishing and Maintenance.** The aggregate subgrade improvement shall be finished to the lines, grades, and cross sections shown on the plans, or as directed by the Engineer. The aggregate subgrade improvement shall be maintained in a smooth and compacted condition.

**303.07 Method of Measurement.** This work will be measured for payment according to Article 311.08.

**303.08 Basis of Payment.** This work will be paid for at the contract unit price per cubic yard (cubic meter) or ton (metric ton) for AGGREGATE SUBGRADE IMPROVEMENT or at the contract unit price per square yard (square meter) for AGGREGATE SUBGRADE IMPROVEMENT, of the thickness specified.”

Add the following to Section 1004 of the Standard Specifications:

**“1004.07 Coarse Aggregate for Aggregate Subgrade Improvement (ASI).** The aggregate shall be according to Article 1004.01 and the following.

- (a) Description. The coarse aggregate shall be crushed gravel, crushed stone, or crushed concrete. In applications where greater than 24 in. (600 mm) of ASI material is required, gravel may be used below the top 12 in (300 mm) of ASI.
- (b) Quality. The coarse aggregate shall consist of sound durable particles reasonably free of deleterious materials.
- (c) Gradation.
  - (1) The coarse aggregate gradation for total ASI thickness less than or equal to 12 in. (300 mm) shall be CA 2, CA 6, CA 10, or CS 1.

The coarse aggregate gradation for total ASI thickness greater than 12 in. (300 mm) shall be CS 1 or CS 2 as shown below or RR 1 according to Article 1005.01(c).

COARSE AGGREGATE SUBGRADE GRADATIONS					
Grad No.	Sieve Size and Percent Passing				
	8”	6”	4”	2”	#4
CS 1	100	97 ± 3	90 ± 10	45 ± 25	20 ± 20
CS 2		100	80 ± 10	25 ± 15	

COARSE AGGREGATE SUBGRADE GRADATIONS (Metric)					
Grad No.	Sieve Size and Percent Passing				
	200 mm	150 mm	100 mm	50 mm	4.75 mm
CS 1	100	97 ± 3	90 ± 10	45 ± 25	20 ± 20
CS 2		100	80 ± 10	25 ± 15	

- (2) Capping aggregate shall be gradation CA 6 or CA 10.”



Add the following to Article 1031.09 of the Standard Specifications:

“(b) RAP in Aggregate Subgrade Improvement (ASI). RAP in ASI shall be according to Articles 1031.01(a), 1031.02(a), 1031.06(a)(1), and 1031.06(a)(2), and the following.

- (1) The testing requirements of Article 1031.03 shall not apply.
- (2) Crushed RAP used for the lower lift may be mechanically blended with aggregate gradations CS 1, CS 2, and RR 1 but it shall be no greater than 40 percent of the total product volume. RAP agglomerations shall be no greater than 4 in. (100 mm).
- (3) For capping aggregate, well graded RAP having 100 percent passing the 1 1/2 in. (38 mm) sieve may be used when aggregate gradations CS 1, CS 2, CA 2, or RR 1 are used in the lower lift. FRAP will not be permitted as capping material.

Blending shall be through calibrated interlocked feeders or a calibrated blending plant such that the prescribed blending percentage is maintained throughout the blending process. The calibration shall have an accuracy of  $\pm 2.0$  percent of the actual quantity of material delivered.”

#### **BITUMINOUS MATERIALS COST ADJUSTMENTS (BDE)**

Effective: November 2, 2006

Revised: August 1, 2017

**Description.** Bituminous material cost adjustments will be made to provide additional compensation to the Contractor, or credit to the Department, for fluctuations in the cost of bituminous materials when optioned by the Contractor. The bidder shall indicate with their bid whether or not this special provision will be part of the contract.

The adjustments shall apply to permanent and temporary hot-mix asphalt (HMA) mixtures, bituminous surface treatments (cover and seal coats), and preventative maintenance type surface treatments that are part of the original proposed construction, or added as extra work and paid for by agreed unit prices. The adjustments shall not apply to bituminous prime coats, tack coats, crack filling/sealing, joint filling/sealing, or extra work paid for at a lump sum price or by force account.

**Method of Adjustment.** Bituminous materials cost adjustments will be computed as follows.

$$CA = (BPI_P - BPI_L) \times (\%AC_V / 100) \times Q$$

- Where: CA = Cost Adjustment, \$.  
BPI<sub>P</sub> = Bituminous Price Index, as published by the Department for the month the work is performed, \$/ton (\$/metric ton).  
BPI<sub>L</sub> = Bituminous Price Index, as published by the Department for the month prior to the letting for work paid for at the contract price; or for the month the agreed unit price letter is submitted by the Contractor for extra work paid for by agreed unit price, \$/ton (\$/metric ton).  
%AC<sub>V</sub> = Percent of virgin Asphalt Cement in the Quantity being adjusted. For HMA mixtures, the % AC<sub>V</sub> will be determined from the adjusted job mix formula. For bituminous materials applied, a performance graded or cutback asphalt will be considered to be 100% AC<sub>V</sub> and undiluted emulsified asphalt will be considered to be 65% AC<sub>V</sub>.  
Q = Authorized construction Quantity, tons (metric tons) (see below).

For HMA mixtures measured in square yards:  $Q, \text{ tons} = A \times D \times (G_{mb} \times 46.8) / 2000$ . For HMA mixtures measured in square meters:  $Q, \text{ metric tons} = A \times D \times (G_{mb} \times 1) / 1000$ . When computing adjustments for full-depth HMA pavement, separate calculations will be made for the binder and surface courses to account for their different  $G_{mb}$  and % AC<sub>V</sub>.

For bituminous materials measured in gallons:  $Q, \text{ tons} = V \times 8.33 \text{ lb/gal} \times SG / 2000$   
For bituminous materials measured in liters:  $Q, \text{ metric tons} = V \times 1.0 \text{ kg/L} \times SG / 1000$

- Where: A = Area of the HMA mixture, sq yd (sq m).  
D = Depth of the HMA mixture, in. (mm).  
G<sub>mb</sub> = Average bulk specific gravity of the mixture, from the approved mix design.  
V = Volume of the bituminous material, gal (L).  
SG = Specific Gravity of bituminous material as shown on the bill of lading.

**Basis of Payment.** Bituminous materials cost adjustments may be positive or negative but will only be made when there is a difference between the BPI<sub>L</sub> and BPI<sub>P</sub> in excess of five percent, as calculated by:

$$\text{Percent Difference} = \{(BPI_L - BPI_P) \div BPI_L\} \times 100$$

Bituminous materials cost adjustments will be calculated for each calendar month in which applicable bituminous material is placed; and will be paid or deducted when all other contract requirements for the work placed during the month are satisfied. The adjustments shall not apply during contract time subject to liquidated damages for completion of the entire contract.

**CEMENT, TYPE IL (BDE)**

Effective: August 1, 2023

Add the following to Article 302.02 of the Standard Specifications:

“(k) Type IL Portland-Limestone Cement .....1001”

Revise Note 2 of Article 352.02 of the Standard Specifications to read:

“Note 2. Either Type I or Type IA portland cement or Type IL portland-limestone cement shall be used.”

Revise Note 1 of Article 404.02 of the Standard Specifications to read:

“Note 1. The cement shall be Type I portland cement or Type IL portland-limestone cement.”

Revise Article 1019.02(a) of the Standard Specifications to read:

“(a) Cement, Type I or IL .....1001”

**COMPENSABLE DELAY COSTS (BDE)**

Effective: June 2, 2017

Revised: April 1, 2019

Revise Article 107.40(b) of the Standard Specifications to read:

“(b) Compensation. Compensation will not be allowed for delays, inconveniences, or damages sustained by the Contractor from conflicts with facilities not meeting the above definition; or if a conflict with a utility in an unanticipated location does not cause a shutdown of the work or a documentable reduction in the rate of progress exceeding the limits set herein. The provisions of Article 104.03 notwithstanding, compensation for delays caused by a utility in an unanticipated location will be paid according to the provisions of this Article governing minor and major delays or reduced rate of production which are defined as follows.

- (1) Minor Delay. A minor delay occurs when the work in conflict with the utility in an unanticipated location is completely stopped for more than two hours, but not to exceed two weeks.
- (2) Major Delay. A major delay occurs when the work in conflict with the utility in an unanticipated location is completely stopped for more than two weeks.
- (3) Reduced Rate of Production Delay. A reduced rate of production delay occurs when the rate of production on the work in conflict with the utility in an unanticipated location decreases by more than 25 percent and lasts longer than seven calendar days.”

Revise Article 107.40(c) of the Standard Specifications to read:

“(c) Payment. Payment for Minor, Major, and Reduced Rate of Production Delays will be made as follows.

- (1) Minor Delay. Labor idled which cannot be used on other work will be paid for according to Article 109.04(b)(1) and (2) for the time between start of the delay and the minimum remaining hours in the work shift required by the prevailing practice in the area.

Equipment idled which cannot be used on other work, and which is authorized to standby on the project site by the Engineer, will be paid for according to Article 109.04(b)(4).

- (2) Major Delay. Labor will be the same as for a minor delay.

Equipment will be the same as for a minor delay, except Contractor-owned equipment will be limited to two weeks plus the cost of move-out to either the Contractor's yard or another job and the cost to re-mobilize, whichever is less. Rental equipment may be paid for longer than two weeks provided the Contractor presents adequate support to the Department (including lease agreement) to show retaining equipment on the job is the most economical course to follow and in the public interest.

- (3) Reduced Rate of Production Delay. The Contractor will be compensated for the reduced productivity for labor and equipment time in excess of the 25 percent threshold for that portion of the delay in excess of seven calendar days. Determination of compensation will be in accordance with Article 104.02, except labor and material additives will not be permitted.

Payment for escalated material costs, escalated labor costs, extended project overhead, and extended traffic control will be determined according to Article 109.13.”

Revise Article 108.04(b) of the Standard Specifications to read:

“(b) No working day will be charged under the following conditions.

- (1) When adverse weather prevents work on the controlling item.
- (2) When job conditions due to recent weather prevent work on the controlling item.
- (3) When conduct or lack of conduct by the Department or its consultants, representatives, officers, agents, or employees; delay by the Department in making the site available; or delay in furnishing any items required to be furnished to the Contractor by the Department prevents work on the controlling item.

- (4) When delays caused by utility or railroad adjustments prevent work on the controlling item.
- (5) When strikes, lock-outs, extraordinary delays in transportation, or inability to procure critical materials prevent work on the controlling item, as long as these delays are not due to any fault of the Contractor.
- (6) When any condition over which the Contractor has no control prevents work on the controlling item.”

Revise Article 109.09(f) of the Standard Specifications to read:

“(f) **Basis of Payment.** After resolution of a claim in favor of the Contractor, any adjustment in time required for the work will be made according to Section 108. Any adjustment in the costs to be paid will be made for direct labor, direct materials, direct equipment, direct jobsite overhead, direct offsite overhead, and other direct costs allowed by the resolution. Adjustments in costs will not be made for interest charges, loss of anticipated profit, undocumented loss of efficiency, home office overhead and unabsorbed overhead other than as allowed by Article 109.13, lost opportunity, preparation of claim expenses and other consequential indirect costs regardless of method of calculation.

The above Basis of Payment is an essential element of the contract and the claim cost recovery of the Contractor shall be so limited.”

Add the following to Section 109 of the Standard Specifications.

“**109.13 Payment for Contract Delay.** Compensation for escalated material costs, escalated labor costs, extended project overhead, and extended traffic control will be allowed when such costs result from a delay meeting the criteria in the following table.

Contract Type	Cause of Delay	Length of Delay
Working Days	Article 108.04(b)(3) or Article 108.04(b)(4)	No working days have been charged for two consecutive weeks.
Completion Date	Article 108.08(b)(1) or Article 108.08(b)(7)	The Contractor has been granted a minimum two week extension of contract time, according to Article 108.08.

Payment for each of the various costs will be according to the following.

- (a) **Escalated Material and/or Labor Costs.** When the delay causes work, which would have otherwise been completed, to be done after material and/or labor costs have increased, such increases will be paid. Payment for escalated material costs will be limited to the increased costs substantiated by documentation furnished by the Contractor. Payment for escalated labor costs will be limited to those items in Article 109.04(b)(1) and (2), except the 35 percent and 10 percent additives will not be permitted.

(b) Extended Project Overhead. For the duration of the delay, payment for extended project overhead will be paid as follows.

(1) Direct Jobsite and Offsite Overhead. Payment for documented direct jobsite overhead and documented direct offsite overhead, including onsite supervisory and administrative personnel, will be allowed according to the following table.

Original Contract Amount	Supervisory and Administrative Personnel
Up to \$5,000,000	One Project Superintendent
Over \$ 5,000,000 - up to \$25,000,000	One Project Manager, One Project Superintendent or Engineer, and One Clerk
Over \$25,000,000 - up to \$50,000,000	One Project Manager, One Project Superintendent, One Engineer, and One Clerk
Over \$50,000,000	One Project Manager, Two Project Superintendents, One Engineer, and One Clerk

(2) Home Office and Unabsorbed Overhead. Payment for home office and unabsorbed overhead will be calculated as 8 percent of the total delay cost.

(c) Extended Traffic Control. Traffic control required for an extended period of time due to the delay will be paid for according to Article 109.04.

When an extended traffic control adjustment is paid under this provision, an adjusted unit price as provided for in Article 701.20(a) for increase or decrease in the value of work by more than ten percent will not be paid.

Upon payment for a contract delay under this provision, the Contractor shall assign subrogation rights to the Department for the Department's efforts of recovery from any other party for monies paid by the Department as a result of any claim under this provision. The Contractor shall fully cooperate with the Department in its efforts to recover from another party any money paid to the Contractor for delay damages under this provision."

**CONSTRUCTION AIR QUALITY – DIESEL RETROFIT (BDE)**

Effective: June 1, 2010

Revised: November 1, 2014

The reduction of emissions of particulate matter (PM) for off-road equipment shall be accomplished by installing retrofit emission control devices. The term “equipment” refers to diesel fuel powered devices rated at 50 hp and above, to be used on the jobsite in excess of seven calendar days over the course of the construction period on the jobsite (including rental equipment).

Contractor and subcontractor diesel powered off-road equipment assigned to the contract shall be retrofitted using the phased in approach shown below. Equipment that is of a model year older than the year given for that equipment’s respective horsepower range shall be retrofitted:

Effective Dates	Horsepower Range	Model Year
June 1, 2010 <sup>1/</sup>	600-749	2002
	750 and up	2006
June 1, 2011 <sup>2/</sup>	100-299	2003
	300-599	2001
	600-749	2002
	750 and up	2006
June 1, 2012 <sup>2/</sup>	50-99	2004
	100-299	2003
	300-599	2001
	600-749	2002
	750 and up	2006

- 1/ Effective dates apply to Contractor diesel powered off-road equipment assigned to the contract.
- 2/ Effective dates apply to Contractor and subcontractor diesel powered off-road equipment assigned to the contract.

The retrofit emission control devices shall achieve a minimum PM emission reduction of 50 percent and shall be:

- a) Included on the U.S. Environmental Protection Agency (USEPA) *Verified Retrofit Technology List* (<http://www.epa.gov/cleandiesel/verification/verif-list.htm>), or verified by the California Air Resources Board (CARB) (<http://www.arb.ca.gov/diesel/verdev/vt/cvt.htm>); or
- b) Retrofitted with a non-verified diesel retrofit emission control device if verified retrofit emission control devices are not available for equipment proposed to be used on the project, and if the Contractor has obtained a performance certification from the retrofit device manufacturer that the emission control device provides a minimum PM emission reduction of 50 percent.

Note: Large cranes (Crawler mounted cranes) which are responsible for critical lift operations are exempt from installing retrofit emission control devices if such devices adversely affect equipment operation.

Diesel powered off-road equipment with engine ratings of 50 hp and above, which are unable to be retrofitted with verified emission control devices or if performance certifications are not available which will achieve a minimum 50 percent PM reduction, may be granted a waiver by the Department if documentation is provided showing good faith efforts were made by the Contractor to retrofit the equipment.

Construction shall not proceed until the Contractor submits a certified list of the diesel powered off-road equipment that will be used, and as necessary, retrofitted with emission control devices. The list(s) shall include (1) the equipment number, type, make, Contractor/rental company name; and (2) the emission control devices make, model, USEPA or CARB verification number, or performance certification from the retrofit device manufacturer. Equipment reported as fitted with emissions control devices shall be made available to the Engineer for visual inspection of the device installation, prior to being used on the jobsite.

The Contractor shall submit an updated list of retrofitted off-road construction equipment as retrofitted equipment changes or comes on to the jobsite. The addition or deletion of any diesel powered equipment shall be included on the updated list.

If any diesel powered off-road equipment is found to be in non-compliance with any portion of this special provision, the Engineer will issue the Contractor a diesel retrofit deficiency deduction.

Any costs associated with retrofitting any diesel powered off-road equipment with emission control devices shall be considered as included in the contract unit prices bid for the various items of work involved and no additional compensation will be allowed. The Contractor's compliance with this notice and any associated regulations shall not be grounds for a claim.

### **Diesel Retrofit Deficiency Deduction**

When the Engineer determines that a diesel retrofit deficiency exists, a daily monetary deduction will be imposed for each calendar day or fraction thereof the deficiency continues to exist. The calendar day(s) will begin when the time period for correction is exceeded and end with the Engineer's written acceptance of the correction. The daily monetary deduction will be \$1,000.00 for each deficiency identified.

The deficiency will be based on lack of diesel retrofit emissions control.

If a Contractor accumulates three diesel retrofit deficiency deductions for the same piece of equipment in a contract period, the Contractor will be shutdown until the deficiency is corrected. Such a shutdown will not be grounds for any extension of the contract time, waiver of penalties, or be grounds for any claim.



## **DISADVANTAGED BUSINESS ENTERPRISE PARTICIPATION (DBE)**

Effective: September 1, 2000

Revised: March 2, 2019

FEDERAL OBLIGATION. The Department of Transportation, as a recipient of federal financial assistance, is required to take all necessary and reasonable steps to ensure nondiscrimination in the award and administration of contracts. Consequently, the federal regulatory provisions of 49 CFR Part 26 apply to this contract concerning the utilization of disadvantaged business enterprises. For the purposes of this Special Provision, a disadvantaged business enterprise (DBE) means a business certified by the Department in accordance with the requirements of 49 CFR Part 26 and listed in the Illinois Unified Certification Program (IL UCP) DBE Directory.

STATE OBLIGATION. This Special Provision will also be used by the Department to satisfy the requirements of the Business Enterprise for Minorities, Females, and Persons with Disabilities Act, 30 ILCS 575. When this Special Provision is used to satisfy state law requirements on 100 percent state-funded contracts, the federal government has no involvement in such contracts (not a federal-aid contract) and no responsibility to oversee the implementation of this Special Provision by the Department on those contracts. DBE participation on 100 percent state-funded contracts will not be credited toward fulfilling the Department's annual overall DBE goal required by the US Department of Transportation to comply with the federal DBE program requirements.

CONTRACTOR ASSURANCE. The Contractor makes the following assurance and agrees to include the assurance in each subcontract the Contractor signs with a subcontractor.

The Contractor, subrecipient, or subcontractor shall not discriminate on the basis of race, color, national origin, or sex in the performance of this contract. The Contractor shall carry out applicable requirements of 49 CFR Part 26 in the award and administration of contracts funded in whole or in part with federal or state funds. Failure by the Contractor to carry out these requirements is a material breach of this contract, which may result in the termination of this contract or such other remedy as the recipient deems appropriate, which may include, but is not limited to:

- (a) Withholding progress payments;
- (b) Assessing sanctions;
- (c) Liquidated damages; and/or
- (d) Disqualifying the Contractor from future bidding as non-responsible.

OVERALL GOAL SET FOR THE DEPARTMENT. As a requirement of compliance with 49 CFR Part 26, the Department has set an overall goal for DBE participation in its federally assisted contracts. That goal applies to all federal-aid funds the Department will expend in its federally assisted contracts for the subject reporting fiscal year. The Department is required to make a good faith effort to achieve the overall goal. The dollar amount paid to all approved DBE companies performing work called for in this contract is eligible to be credited toward fulfillment of the Department's overall goal.

**CONTRACT GOAL TO BE ACHIEVED BY THE CONTRACTOR.** This contract includes a specific DBE utilization goal established by the Department. The goal has been included because the Department has determined the work of this contract has subcontracting opportunities that may be suitable for performance by DBE companies. The determination is based on an assessment of the type of work, the location of the work, and the availability of DBE companies to do a part of the work. The assessment indicates, in the absence of unlawful discrimination and in an arena of fair and open competition, DBE companies can be expected to perform **21.00%** of the work. This percentage is set as the DBE participation goal for this contract. Consequently, in addition to the other award criteria established for this contract, the Department will only award this contract to a bidder who makes a good faith effort to meet this goal of DBE participation in the performance of the work. A bidder makes a good faith effort for award consideration if either of the following is done in accordance with the procedures set for in this Special Provision:

- (a) The bidder documents enough DBE participation has been obtained to meet the goal or,
- (b) The bidder documents a good faith effort has been made to meet the goal, even though the effort did not succeed in obtaining enough DBE participation to meet the goal.

**DBE LOCATOR REFERENCES.** Bidders shall consult the IL UCP DBE Directory as a reference source for DBE-certified companies. In addition, the Department maintains a letting and item specific DBE locator information system whereby DBE companies can register their interest in providing quotes on particular bid items advertised for letting. Information concerning DBE companies willing to quote work for particular contracts may be obtained by contacting the Department's Bureau of Small Business Enterprises at telephone number (217) 785-4611, or by visiting the Department's website at:  
<http://www.idot.illinois.gov/doing-business/certifications/disadvantaged-business-enterprise-certification/il-ucp-directory/index>.

**BIDDING PROCEDURES.** Compliance with this Special Provision is a material bidding requirement and failure of the bidder to comply will render the bid not responsive.

The bidder shall submit a DBE Utilization Plan (form SBE 2026), and a DBE Participation Statement (form SBE 2025) for each DBE company proposed for the performance of work to achieve the contract goal, with the bid. If the Utilization Plan indicates the contract goal will not be met, documentation of good faith efforts shall also be submitted. The documentation of good faith efforts must include copies of each DBE and non-DBE subcontractor quote submitted to the bidder when a non-DBE subcontractor is selected over a DBE for work on the contract. The required forms and documentation must be submitted as a single .pdf file using the "Integrated Contractor Exchange (iCX)" application within the Department's "EBids System".

The Department will not accept a Utilization Plan if it does not meet the bidding procedures set forth herein and the bid will be declared not responsive. In the event the bid is declared not responsive, the Department may elect to cause the forfeiture of the penal sum of the bidder's proposal guaranty and may deny authorization to bid the project if re-advertised for bids.

GOOD FAITH EFFORT PROCEDURES. The contract will not be awarded until the Utilization Plan is approved. All information submitted by the bidder must be complete, accurate and adequately document enough DBE participation has been obtained or document the good faith efforts of the bidder, in the event enough DBE participation has not been obtained, before the Department will commit to the performance of the contract by the bidder. The Utilization Plan will be approved by the Department if the Utilization Plan documents sufficient commercially useful DBE work to meet the contract goal or the bidder submits sufficient documentation of a good faith effort to meet the contract goal pursuant to 49 CFR Part 26, Appendix A. This means the bidder must show that all necessary and reasonable steps were taken to achieve the contract goal. Necessary and reasonable steps are those which, by their scope, intensity and appropriateness to the objective, could reasonably be expected to obtain sufficient DBE participation, even if they were not successful. The Department will consider the quality, quantity, and intensity of the kinds of efforts the bidder has made. Mere *pro forma* efforts, in other words efforts done as a matter of form, are not good faith efforts; rather, the bidder is expected to have taken genuine efforts that would be reasonably expected of a bidder actively and aggressively trying to obtain DBE participation sufficient to meet the contract goal.

- (a) The following is a list of types of action that the Department will consider as part of the evaluation of the bidder's good faith efforts to obtain participation. These listed factors are not intended to be a mandatory checklist and are not intended to be exhaustive. Other factors or efforts brought to the attention of the Department may be relevant in appropriate cases and will be considered by the Department.
  - (1) Soliciting through all reasonable and available means (e.g. attendance at pre-bid meetings, advertising and/or written notices) the interest of all certified DBE companies that have the capability to perform the work of the contract. The bidder must solicit this interest within sufficient time to allow the DBE companies to respond to the solicitation. The bidder must determine with certainty if the DBE companies are interested by taking appropriate steps to follow up initial solicitations.
  - (2) Selecting portions of the work to be performed by DBE companies in order to increase the likelihood that the DBE goals will be achieved. This includes, where appropriate, breaking out contract work items into economically feasible units to facilitate DBE participation, even when the Contractor might otherwise prefer to perform these work items with its own forces.
  - (3) Providing interested DBE companies with adequate information about the plans, specifications, and requirements of the contract in a timely manner to assist them in responding to a solicitation.

- (4) a. Negotiating in good faith with interested DBE companies. It is the bidder's responsibility to make a portion of the work available to DBE subcontractors and suppliers and to select those portions of the work or material needs consistent with the available DBE subcontractors and suppliers, so as to facilitate DBE participation. Evidence of such negotiation includes the names, addresses, and telephone numbers of DBE companies that were considered; a description of the information provided regarding the plans and specifications for the work selected for subcontracting; and evidence as to why additional agreements could not be reached for DBE companies to perform the work.
  - b. A bidder using good business judgment would consider a number of factors in negotiating with subcontractors, including DBE subcontractors, and would take a firm's price and capabilities as well as contract goals into consideration. However, the fact that there may be some additional costs involved in finding and using DBE companies is not in itself sufficient reason for a bidder's failure to meet the contract DBE goal, as long as such costs are reasonable. Also the ability or desire of a bidder to perform the work of a contract with its own organization does not relieve the bidder of the responsibility to make good faith efforts. Bidders are not, however, required to accept higher quotes from DBE companies if the price difference is excessive or unreasonable. In accordance with the above Bidding Procedures, the documentation of good faith efforts must include copies of each DBE and non-DBE subcontractor quote submitted to the bidder when a non-DBE subcontractor was selected over a DBE for work on the contract.
- (5) Not rejecting DBE companies as being unqualified without sound reasons based on a thorough investigation of their capabilities. The bidder's standing within its industry, membership in specific groups, organizations, or associations and political or social affiliations (for example union vs. non-union employee status) are not legitimate causes for the rejection or non-solicitation of bids in the bidder's efforts to meet the project goal.
  - (6) Making efforts to assist interested DBE companies in obtaining bonding, lines of credit, or insurance as required by the recipient or Contractor.
  - (7) Making efforts to assist interested DBE companies in obtaining necessary equipment, supplies, materials, or related assistance or services.
  - (8) Effectively using the services of available minority/women community organizations; minority/women contractors' groups; local, state, and federal minority/women business assistance offices; and other organizations as allowed on a case-by-case basis to provide assistance in the recruitment and placement of DBE companies.

- (b) If the Department determines the bidder has made a good faith effort to secure the work commitment of DBE companies to meet the contract goal, the Department will award the contract provided it is otherwise eligible for award. If the Department determines the bidder has failed to meet the requirements of this Special Provision or that a good faith effort has not been made, the Department will notify the responsible company official designated in the Utilization Plan that the bid is not responsive. The notification will also include a statement of reasons for the adverse determination. If the Utilization Plan is not approved because it is deficient as a technical matter, unless waived by the Department, the bidder will be notified and will be allowed no more than a five calendar day period to cure the deficiency.
- (c) The bidder may request administrative reconsideration of an adverse determination by emailing the Department at "[DOT.DBE.UP@illinois.gov](mailto:DOT.DBE.UP@illinois.gov)" within the five calendar days after the receipt of the notification of the determination. The determination shall become final if a request is not made on or before the fifth calendar day. A request may provide additional written documentation or argument concerning the issues raised in the determination statement of reasons, provided the documentation and arguments address efforts made prior to submitting the bid. The request will be reviewed by the Department's Reconsideration Officer. The Reconsideration Officer will extend an opportunity to the bidder to meet in person to consider all issues of documentation and whether the bidder made a good faith effort to meet the goal. After the review by the Reconsideration Officer, the bidder will be sent a written decision within ten working days after receipt of the request for reconsideration, explaining the basis for finding that the bidder did or did not meet the goal or make adequate good faith efforts to do so. A final decision by the Reconsideration Officer that a good faith effort was made shall approve the Utilization Plan submitted by the bidder and shall clear the contract for award. A final decision that a good faith effort was not made shall render the bid not responsive.

CALCULATING DBE PARTICIPATION. The Utilization Plan values represent work anticipated to be performed and paid for upon satisfactory completion. The Department is only able to count toward the achievement of the overall goal and the contract goal the value of payments made for the work actually performed by DBE companies. In addition, a DBE must perform a commercially useful function on the contract to be counted. A commercially useful function is generally performed when the DBE is responsible for the work and is carrying out its responsibilities by actually performing, managing, and supervising the work involved. The Department and Contractor are governed by the provisions of 49 CFR Part 26.55(c) on questions of commercially useful functions as it affects the work. Specific counting guidelines are provided in 49 CFR Part 26.55, the provisions of which govern over the summary contained herein.

- (a) DBE as the Contractor: 100 percent goal credit for that portion of the work performed by the DBE's own forces, including the cost of materials and supplies. Work that a DBE subcontracts to a non-DBE does not count toward the DBE goals.
- (b) DBE as a joint venture Contractor: 100 percent goal credit for that portion of the total dollar value of the contract equal to the distinct, clearly defined portion of the work performed by the DBE's own forces.

- (c) DBE as a subcontractor: 100 percent goal credit for the work of the subcontract performed by the DBE's own forces, including the cost of materials and supplies, excluding the purchase of materials and supplies or the lease of equipment by the DBE subcontractor from the Contractor or its affiliates. Work that a DBE subcontractor in turn subcontracts to a non-DBE does not count toward the DBE goal.
- (d) DBE as a trucker: 100 percent goal credit for trucking participation provided the DBE is responsible for the management and supervision of the entire trucking operation for which it is responsible. At least one truck owned, operated, licensed, and insured by the DBE must be used on the contract. Credit will be given for the following:
  - (1) The DBE may lease trucks from another DBE firm, including an owner-operator who is certified as a DBE. The DBE who leases trucks from another DBE receives credit for the total value of the transportation services the lessee DBE provides on the contract.
  - (2) The DBE may also lease trucks from a non-DBE firm, including from an owner-operator. The DBE who leases trucks from a non-DBE is entitled to credit only for the fee or commission is receives as a result of the lease arrangement.
- (e) DBE as a material supplier:
  - (1) 60 percent goal credit for the cost of the materials or supplies purchased from a DBE regular dealer.
  - (2) 100 percent goal credit for the cost of materials of supplies obtained from a DBE manufacturer.
  - (3) 100 percent credit for the value of reasonable fees and commissions for the procurement of materials and supplies if not a DBE regular dealer or DBE manufacturer.

**CONTRACT COMPLIANCE.** Compliance with this Special Provision is an essential part of the contract. The Department is prohibited by federal regulations from crediting the participation of a DBE included in the Utilization Plan toward either the contract goal or the Department's overall goal until the amount to be applied toward the goals has been paid to the DBE. The following administrative procedures and remedies govern the compliance by the Contractor with the contractual obligations established by the Utilization Plan. After approval of the Utilization Plan and award of the contract, the Utilization Plan and individual DBE Participation Statements become part of the contract. If the Contractor did not succeed in obtaining enough DBE participation to achieve the advertised contract goal, and the Utilization Plan was approved and contract awarded based upon a determination of good faith, the total dollar value of DBE work calculated in the approved Utilization Plan as a percentage of the awarded contract value shall become the amended contract goal. All work indicated for performance by an approved DBE shall be performed, managed, and supervised by the DBE executing the DBE Participation Commitment Statement.

- (a) NO AMENDMENT. No amendment to the Utilization Plan may be made without prior written approval from the Department's Bureau of Small Business Enterprises. All requests for amendment to the Utilization Plan shall be emailed to the Department at [DOT.DBE.UP@illinois.gov](mailto:DOT.DBE.UP@illinois.gov).
- (b) CHANGES TO WORK. Any deviation from the DBE condition-of-award or contract plans, specifications, or special provisions must be approved, in writing, by the Department as provided elsewhere in the Contract. The Contractor shall notify affected DBEs in writing of any changes in the scope of work which result in a reduction in the dollar amount condition-of-award to the contract. Where the revision includes work committed to a new DBE subcontractor, not previously involved in the project, then a Request for Approval of Subcontractor, Department form BC 260A or AER 260A, must be signed and submitted. If the commitment of work is in the form of additional tasks assigned to an existing subcontract, a new Request for Approval of Subcontractor will not be required. However, the Contractor must document efforts to assure the existing DBE subcontractor is capable of performing the additional work and has agreed in writing to the change.
- (c) SUBCONTRACT. The Contractor must provide copies of DBE subcontracts to the Department upon request. Subcontractors shall ensure that all lower tier subcontracts or agreements with DBEs to supply labor or materials be performed in accordance with this Special Provision.
- (d) ALTERNATIVE WORK METHODS. In addition to the above requirements for reductions in the condition of award, additional requirements apply to the two cases of Contractor-initiated work substitution proposals. Where the contract allows alternate work methods which serve to delete or create underruns in condition of award DBE work, and the Contractor selects that alternate method or, where the Contractor proposes a substitute work method or material that serves to diminish or delete work committed to a DBE and replace it with other work, then the Contractor must demonstrate one of the following:
- (1) The replacement work will be performed by the same DBE (as long as the DBE is certified in the respective item of work) in a modification of the condition of award; or
  - (2) The DBE is aware its work will be deleted or will experience underruns and has agreed in writing to the change. If this occurs, the Contractor shall substitute other work of equivalent value to a certified DBE or provide documentation of good faith efforts to do so; or
  - (3) The DBE is not capable of performing the replacement work or has declined to perform the work at a reasonable competitive price. If this occurs, the Contractor shall substitute other work of equivalent value to a certified DBE or provide documentation of good faith efforts to do so.

- (e) TERMINATION AND REPLACEMENT PROCEDURES. The Contractor shall not terminate or replace a DBE listed on the approved Utilization Plan, or perform with other forces work designated for a listed DBE except as provided in this Special Provision. The Contractor shall utilize the specific DBEs listed to perform the work and supply the materials for which each is listed unless the Contractor obtains the Department's written consent as provided in subsection (a) of this part. Unless Department consent is provided for termination of a DBE subcontractor, the Contractor shall not be entitled to any payment for work or material unless it is performed or supplied by the DBE in the Utilization Plan.

As stated above, the Contractor shall not terminate or replace a DBE subcontractor listed in the approved Utilization Plan without prior written consent. This includes, but is not limited to, instances in which the Contractor seeks to perform work originally designated for a DBE subcontractor with its own forces or those of an affiliate, a non-DBE firm, or with another DBE firm. Written consent will be granted only if the Bureau of Small Business Enterprises agrees, for reasons stated in its concurrence document, that the Contractor has good cause to terminate or replace the DBE firm. Before transmitting to the Bureau of Small Business Enterprises any request to terminate and/or substitute a DBE subcontractor, the Contractor shall give notice in writing to the DBE subcontractor, with a copy to the Bureau, of its intent to request to terminate and/or substitute, and the reason for the request. The Contractor shall give the DBE five days to respond to the Contractor's notice. The DBE so notified shall advise the Bureau and the Contractor of the reasons, if any, why it objects to the proposed termination of its subcontract and why the Bureau should not approve the Contractor's action. If required in a particular case as a matter of public necessity, the Bureau may provide a response period shorter than five days.

For purposes of this paragraph, good cause includes the following circumstances:

- (1) The listed DBE subcontractor fails or refuses to execute a written contract;
- (2) The listed DBE subcontractor fails or refuses to perform the work of its subcontract in a way consistent with normal industry standards. Provided, however, that good cause does not exist if the failure or refusal of the DBE subcontractor to perform its work on the subcontract results from the bad faith or discriminatory action of the Contractor;
- (3) The listed DBE subcontractor fails or refuses to meet the Contractor's reasonable, nondiscriminatory bond requirements;
- (4) The listed DBE subcontractor becomes bankrupt, insolvent, or exhibits credit unworthiness;
- (5) The listed DBE subcontractor is ineligible to work on public works projects because of suspension and debarment proceedings pursuant 2 CFR Parts 180, 215 and 1200 or applicable state law.
- (6) The Contractor has determined the listed DBE subcontractor is not a responsible contractor;



- (7) The listed DBE subcontractor voluntarily withdraws from the projects and provides written notice to the Contractor of its withdrawal;
- (8) The listed DBE is ineligible to receive DBE credit for the type of work required;
- (9) A DBE owner dies or becomes disabled with the result that the listed DBE subcontractor is unable to complete its work on the contract;
- (10) Other documented good cause that compels the termination of the DBE subcontractor. Provided, that good cause does not exist if the Contractor seeks to terminate a DBE it relied upon to obtain the contract so that the Contractor can self-perform the work for which the DBE contractor was engaged or so that the Contractor can substitute another DBE or non-DBE contractor after contract award.

When a DBE is terminated or fails to complete its work on the Contract for any reason, the Contractor shall make a good faith effort to find another DBE to substitute for the original DBE to perform at least the same amount of work under the contract as the terminated DBE to the extent needed to meet the established Contract goal. The good faith efforts shall be documented by the Contractor. If the Department requests documentation under this provision, the Contractor shall submit the documentation within seven days, which may be extended for an additional seven days if necessary at the request of the Contractor. The Department will provide a written determination to the Contractor stating whether or not good faith efforts have been demonstrated.

- (f) FINAL PAYMENT. After the performance of the final item of work or delivery of material by a DBE and final payment therefore to the DBE by the Contractor, but not later than 30 calendar days after payment has been made by the Department to the Contractor for such work or material, the Contractor shall submit a DBE Payment Agreement on Department form SBE 2115 to the Resident Engineer. If full and final payment has not been made to the DBE, the DBE Payment Agreement shall indicate whether a disagreement as to the payment required exists between the Contractor and the DBE or if the Contractor believes the work has not been satisfactorily completed. If the Contractor does not have the full amount of work indicated in the Utilization Plan performed by the DBE companies indicated in the Utilization Plan and after good faith efforts are reviewed, the Department may deduct from contract payments to the Contractor the amount of the goal not achieved as liquidated and ascertained damages. The Contractor may request an administrative reconsideration of any amount deducted as damages pursuant to subsection (h) of this part.
- (g) ENFORCEMENT. The Department reserves the right to withhold payment to the Contractor to enforce the provisions of this Special Provision. Final payment shall not be made on the contract until such time as the Contractor submits sufficient documentation demonstrating achievement of the goal in accordance with this Special Provision or after liquidated damages have been determined and collected.

- (h) **RECONSIDERATION.** Notwithstanding any other provision of the contract, including but not limited to Article 109.09 of the Standard Specifications, the Contractor may request administrative reconsideration of a decision to deduct the amount of the goal not achieved as liquidated damages. A request to reconsider shall be delivered to the Contract Compliance Section and shall be handled and considered in the same manner as set forth in paragraph (c) of "Good Faith Effort Procedures" of this Special Provision, except a final decision that a good faith effort was not made during contract performance to achieve the goal agreed to in the Utilization Plan shall be the final administrative decision of the Department. The result of the reconsideration process is not administratively appealable to the U.S. Department of Transportation.

## **FUEL COST ADJUSTMENT (BDE)**

Effective: April 1, 2009

Revised: August 1, 2017

**Description.** Fuel cost adjustments will be made to provide additional compensation to the Contractor, or a credit to the Department, for fluctuations in fuel prices when optioned by the Contractor. The bidder shall indicate with their bid whether or not this special provision will be part of the contract. Failure to indicate "Yes" for any category of work will make that category of work exempt from fuel cost adjustment.

**General.** The fuel cost adjustment shall apply to contract pay items as grouped by category. The adjustment shall only apply to those categories of work checked "Yes", and only when the cumulative plan quantities for a category exceed the required threshold. Adjustments to work items in a category, either up or down, and extra work paid for by agreed unit price will be subject to fuel cost adjustment only when the category representing the added work was subject to the fuel cost adjustment. Extra work paid for at a lump sum price or by force account will not be subject to fuel cost adjustment. Category descriptions and thresholds for application and the fuel usage factors which are applicable to each are as follows:

(a) Categories of Work.

- (1) Category A: Earthwork. Contract pay items performed under Sections 202, 204, and 206 including any modified standard or nonstandard items where the character of the work to be performed is considered earthwork. The cumulative total of all applicable item plan quantities shall exceed 25,000 cu yd (20,000 cu m). Included in the fuel usage factor is a weighted average 0.10 gal/cu yd (0.50 liters/cu m) factor for trucking.
- (2) Category B: Subbases and Aggregate Base Courses. Contract pay items constructed under Sections 311, 312 and 351 including any modified standard or nonstandard items where the character of the work to be performed is considered construction of a subbase or aggregate, stabilized or modified base course. The cumulative total of all applicable item plan quantities shall exceed 5000 tons (4500 metric tons). Included in the fuel usage factor is a 0.60 gal/ton (2.50 liters/metric ton) factor for trucking.

- (3) Category C: Hot-Mix Asphalt (HMA) Bases, Pavements and Shoulders. Contract pay items constructed under Sections 355, 406, 407 and 482 including any modified standard or nonstandard items where the character of the work to be performed is considered HMA bases, pavements and shoulders. The cumulative total of all applicable item plan quantities shall exceed 5000 tons (4500 metric tons). Included in the fuel usage factor is 0.60 gal/ton (2.50 liters/metric ton) factor for trucking.
- (4) Category D: Portland Cement Concrete (PCC) Bases, Pavements and Shoulders. Contract pay items constructed under Sections 353, 420, 421 and 483 including any modified standard or nonstandard items where the character of the work to be performed is considered PCC base, pavement or shoulder. The cumulative total of all applicable item plan quantities shall exceed 7500 sq yd (6000 sq m). Included in the fuel usage factor is 1.20 gal/cu yd (5.94 liters/cu m) factor for trucking.
- (5) Category E: Structures. Structure items having a cumulative bid price that exceeds \$250,000 for pay items constructed under Sections 502, 503, 504, 505, 512, 516 and 540 including any modified standard or nonstandard items where the character of the work to be performed is considered structure work when similar to that performed under these sections and not included in categories A through D.

(b) Fuel Usage Factors.

English Units		
Category	Factor	Units
A - Earthwork	0.34	gal / cu yd
B – Subbase and Aggregate Base courses	0.62	gal / ton
C – HMA Bases, Pavements and Shoulders	1.05	gal / ton
D – PCC Bases, Pavements and Shoulders	2.53	gal / cu yd
E – Structures	8.00	gal / \$1000

Metric Units		
Category	Factor	Units
A - Earthwork	1.68	liters / cu m
B – Subbase and Aggregate Base courses	2.58	liters / metric ton
C – HMA Bases, Pavements and Shoulders	4.37	liters / metric ton
D – PCC Bases, Pavements and Shoulders	12.52	liters / cu m
E – Structures	30.28	liters / \$1000

(c) Quantity Conversion Factors.

Category	Conversion	Factor
B	sq yd to ton	0.057 ton / sq yd / in depth
	sq m to metric ton	0.00243 metric ton / sq m / mm depth
C	sq yd to ton	0.056 ton / sq yd / in depth
	sq m to metric ton	0.00239 m ton / sq m / mm depth
D	sq yd to cu yd	0.028 cu yd / sq yd / in depth
	sq m to cu m	0.001 cu m / sq m / mm depth

Method of Adjustment. Fuel cost adjustments will be computed as follows.

$$CA = (FPI_P - FPI_L) \times FUF \times Q$$

- Where: CA = Cost Adjustment, \$  
 FPI<sub>P</sub> = Fuel Price Index, as published by the Department for the month the work is performed, \$/gal (\$/liter)  
 FPI<sub>L</sub> = Fuel Price Index, as published by the Department for the month prior to the letting for work paid for at the contract price; or for the month the agreed unit price letter is submitted by the Contractor for extra work paid for by agreed unit price, \$/gal (\$/liter)  
 FUF = Fuel Usage Factor in the pay item(s) being adjusted  
 Q = Authorized construction Quantity, tons (metric tons) or cu yd (cu m)

The entire FUF indicated in paragraph (b) will be used regardless of use of trucking to perform the work.

Basis of Payment. Fuel cost adjustments may be positive or negative but will only be made when there is a difference between the FPI<sub>L</sub> and FPI<sub>P</sub> in excess of five percent, as calculated by:

$$\text{Percent Difference} = \{(FPI_L - FPI_P) \div FPI_L\} \times 100$$

Fuel cost adjustments will be calculated for each calendar month in which applicable work is performed; and will be paid or deducted when all other contract requirements for the items of work are satisfied. The adjustments shall not apply during contract time subject to liquidated damages for completion of the entire contract.

## **HOT-MIX ASPHALT (BDE)**

Effective: January 1, 2024

Revise the second paragraph of Articles 1030.07(a)(11) and 1030.08(a)(9) of the Standard Specifications to read:

“When establishing the target density, the HMA maximum theoretical specific gravity ( $G_{mm}$ ) will be based on the running average of four available Department test results for that project. If less than four  $G_{mm}$  test results are available, an average of all available Department test results for that project will be used. The initial  $G_{mm}$  will be the last available Department test result from a QMP project. If there is no available Department test result from a QMP project, the Department mix design verification test result will be used as the initial  $G_{mm}$ .”

In the Supplemental Specifications, replace the revision for the end of the third paragraph of Article 1030.09(h)(2) with the following:

“When establishing the target density, the HMA maximum theoretical specific gravity ( $G_{mm}$ ) will be the Department mix design verification test result.”

Revise the tenth paragraph of Article 1030.10 of the Standard Specifications to read:

“Production is not required to stop after a test strip has been constructed.”

## **HOT-MIX ASPHALT – LONGITUDINAL JOINT SEALANT (BDE)**

Effective: November 1, 2022

Revised: August 1, 2023

Add the following after the second sentence in the eighth paragraph of Article 406.06(h)(2) of the Standard Specifications:

“If rain is forecasted and traffic is to be on the LJS or if pickup/tracking of the LJS material is likely, the LJS shall be covered immediately following its application with FA 20 fine aggregate mechanically spread uniformly at a rate of  $1.5 \pm 0.5$  lb/sq yd ( $0.75 \pm 0.25$  kg/sq m). Fine aggregate landing outside of the LJS shall be removed prior to application of tack coat.”

Add the following after the first sentence in the ninth paragraph of Article 406.06(h)(2) of the Standard Specifications:

“LJS half-width shall be applied at a width of  $9 \pm 1$  in. ( $225 \pm 25$  mm) in the immediate lane to be placed with the outside edge flush with the joint of the next HMA lift. The vertical face of any longitudinal joint remaining in place shall also be coated.”

Add the following after the eleventh paragraph of Article 406.06(h)(2) of the Standard Specifications:

“LJS Half-Width Application Rate, lb/ft (kg/m) <sup>1/</sup>			
Lift Thickness, in. (mm)	Coarse Graded Mixture (IL-19.0, IL-19.0L, IL-9.5, IL-9.5L, IL-4.75)	Fine Graded Mixture (IL-9.5FG)	SMA Mixture (SMA-9.5, SMA-12.5)
¾ (19)	0.44 (0.66)		
1 (25)	0.58 (0.86)		
1 ¼ (32)	0.66 (0.98)	0.44 (0.66)	
1 ½ (38)	0.74 (1.10)	0.48 (0.71)	0.63 (0.94)
1 ¾ (44)	0.82 (1.22)	0.52 (0.77)	0.69 (1.03)
2 (50)	0.90 (1.34)	0.56 (0.83)	0.76 (1.13)
≥ 2 ¼ (60)	0.98 (1.46)		

1/ The application rate includes a surface demand for liquid. The thickness of the LJS may taper from the center of the application to a lesser thickness on the edge of the application, provided the correct width and application rate are maintained.”

Revise the second paragraph of Article 406.13(b) of the Standard Specifications to read:

“Aggregate for covering tack, LJS, or FLS will not be measured for payment.”

Add the following to the end of the second paragraph of Article 406.14 of the Standard Specifications:

“Longitudinal joint sealant (LJS) half-width will be paid for at the contract unit price per foot (meter) for LONGITUDINAL JOINT SEALANT, HALF-WIDTH.”

**MATERIAL TRANSFER DEVICE (BDE)**

Effective: June 15, 1999

Revised: January 1, 2022

Add the following to Article 406.03 of the Standard Specifications:

“(n) Material Transfer Device ..... 1102.02”

Add the following to the end of Article 406.06(f) of the Standard Specifications:

“When required, a material transfer device (MTD) shall be used to transfer the HMA from the haul trucks to the spreading and finishing machine. The particular HMA mixtures for which an MTD is required will be specified in the plans. When not required, an MTD may still be used at the Contractor’s option, subject to the requirements and restrictions herein. Use of MTDs shall be according to the following.

MTD Category	Usage
Category I	Any resurfacing application Full-Depth HMA where the in-place binder thickness is $\geq$ 10 in. (250 mm)
Category II	Full-Depth HMA where the in-place binder thickness is $<$ 10 in. (250 mm)

Category I MTD’s will only be allowed to travel over structures under the following conditions:

- (1) Approval will be given by the Engineer.
- (2) The MTD shall be emptied of HMA material prior to crossing the structure and shall travel at crawl speed across the structure.
- (3) The tires of the MTD shall travel on or in close proximity and parallel to the beam and/or girder lines of the structure.”

Add the following to the end of Article 406.13(b) of the Standard Specifications:

“The required use of an MTD will be measured for payment in tons (metric tons) of the HMA mixtures placed with the MTD. The use of an MTD at the Contractor’s option will not be measured for payment.”

Add the following between the second and third paragraphs of Article 406.14 of the Standard Specifications:

“The required use of an MTD will be paid for at the contract unit price per ton (metric ton) for MATERIAL TRANSFER DEVICE. The HMA mixtures placed with the MTD will be paid for separately according to their respective specifications.”

Revise Article 1102.02 of the Standard Specifications to read:

“**1102.02 Material Transfer Device (MTD).** The MTD shall be according to the following.

- (a) Requirements. The MTD shall have a minimum surge capacity of 15 tons (13.5 metric tons), shall be self-propelled and capable of moving independent of the paver, and shall be equipped with the following.
  - (1) Front-Dump Hopper and Conveyor. The conveyor shall provide a positive restraint along the sides of the conveyor to prevent material spillage. MTDs having paver style hoppers shall have a horizontal bar restraint placed across the foldable wings which prevents the wings from being folded.
  - (2) Paver Hopper Insert. The paver hopper insert shall have a minimum capacity of 14 tons (12.7 metric tons).
  - (3) Mixer/Agitator Mechanism. This re-mixing mechanism shall consist of a segmented, anti-segregation, re-mixing auger.
- (b) Qualification and Designation. The MTD shall be on the Department’s qualified product list with one of the following designations.
  - (1) Category I. The MTD has a documented maximum HMA carrying capacity contact pressure greater than 25 psi and has a central surge hopper of sufficient capacity to mix upstream HMA with downstream HMA.
  - (2) Category II. The MTD has a documented maximum HMA carrying capacity contact pressure less than or equal to 25 psi.”



**MECHANICALLY STABILIZED EARTH RETAINING WALLS (BDE)**

Effective: August 1, 2023

Revise the second sentence of Articles 1003.07(d) and 1004.06(d) of the Standard Specifications to read:

“The Illinois Modified AASHTO T 296 test with pore pressure measurement may be used in lieu of AASHTO T 236.”

Add the following to Article 522.02 of the Standard Specifications:

“(s) Metal Hardware Cast into Concrete..... 1006.13”

**PERFORMANCE GRADED ASPHALT BINDER (BDE)**

Effective: January 1, 2023

Revise Article 1032.05 of the Standard Specifications to read:

“**1032.05 Performance Graded Asphalt Binder.** These materials will be accepted according to the Bureau of Materials Policy Memorandum, “Performance Graded Asphalt Binder Qualification Procedure.” The Department will maintain a qualified producer list. These materials shall be free from water and shall not foam when heated to any temperature below the actual flash point. Air blown asphalt, recycle engine oil bottoms (ReOB), and polyphosphoric acid (PPA) modification shall not be used.

When requested, producers shall provide the Engineer with viscosity/temperature relationships for the performance graded asphalt binders delivered and incorporated in the work.

- (a) Performance Graded (PG) Asphalt Binder. The asphalt binder shall meet the requirements of AASHTO M 320, Table 1 “Standard Specification for Performance Graded Asphalt Binder” for the grade shown on the plans and the following.

Test	Parameter
Small Strain Parameter (AASHTO PP 113) BBR, $\Delta T_c$ , 40 hrs PAV (40 hrs continuous or 2 PAV at 20 hrs)	-5 °C min.

- (b) Modified Performance Graded (PG) Asphalt Binder. The asphalt binder shall meet the requirements of AASHTO M 320, Table 1 “Standard Specification for Performance Graded Asphalt Binder” for the grade shown on the plans.

Asphalt binder modification shall be performed at the source, as defined in the Bureau of Materials Policy Memorandum, “Performance Graded Asphalt Binder Qualification Procedure.”

Modified asphalt binder shall be safe to handle at asphalt binder production and storage temperatures or HMA construction temperatures. Safety Data Sheets (SDS) shall be provided for all asphalt modifiers.

- (1) Polymer Modification (SB/SBS or SBR). Elastomers shall be added to the base asphalt binder to achieve the specified performance grade and shall be either a styrene-butadiene diblock, triblock copolymer without oil extension, or a styrene-butadiene rubber. The polymer modified asphalt binder shall be smooth, homogeneous, and be according to the requirements shown in Table 1 or 2 for the grade shown on the plans.

Table 1 - Requirements for Styrene-Butadiene Copolymer (SB/SBS) Modified Asphalt Binders		
Test	Asphalt Grade SB/SBS PG 64-28 SB/SBS PG 70-22	Asphalt Grade SB/SBS PG 64-34 SB/SBS PG 70-28 SB/SBS PG 76-22 SB/SBS PG 76-28
Separation of Polymer ITP, "Separation of Polymer from Asphalt Binder" Difference in °F (°C) of the softening point between top and bottom portions	4 (2) max.	4 (2) max.
TESTS ON RESIDUE FROM ROLLING THIN FILM OVEN TEST (AASHTO T 240)		
Elastic Recovery ASTM D 6084, Procedure A, 77 °F (25 °C), 100 mm elongation, %	60 min.	70 min.

Table 2 - Requirements for Styrene-Butadiene Rubber (SBR) Modified Asphalt Binders		
Test	Asphalt Grade SBR PG 64-28 SBR PG 70-22	Asphalt Grade SB/SBS PG 64-34 SB/SBS PG 70-28 SBR PG 76-22 SBR PG 76-28
Separation of Polymer ITP, "Separation of Polymer from Asphalt Binder" Difference in °F (°C) of the softening point between top and bottom portions	4 (2) max.	4 (2) max.
Toughness ASTM D 5801, 77 °F (25 °C), 20 in./min. (500 mm/min.), in.-lbs (N-m)	110 (12.5) min.	110 (12.5) min.
Tenacity ASTM D 5801, 77 °F (25 °C), 20 in./min. (500 mm/min.), in.-lbs (N-m)	75 (8.5) min.	75 (8.5) min.
<b>TESTS ON RESIDUE FROM ROLLING THIN FILM OVEN TEST (AASHTO T 240)</b>		
Elastic Recovery ASTM D 6084, Procedure A, 77 °F (25 °C), 100 mm elongation, %	40 min.	50 min.

- (2) Ground Tire Rubber (GTR) Modification. GTR modification is the addition of recycled ground tire rubber to liquid asphalt binder to achieve the specified performance grade. GTR shall be produced from processing automobile and/or truck tires by the ambient grinding method or micronizing through a cryogenic process. GTR shall not exceed 1/16 in. (2 mm) in any dimension and shall not contain free metal particles, moisture that would cause foaming of the asphalt, or other foreign materials. A mineral powder (such as talc) meeting the requirements of AASHTO M 17 may be added, up to a maximum of four percent by weight of GTR to reduce sticking and caking of the GTR particles. When tested in accordance with Illinois Modified AASHTO T 27 "Standard Method of Test for Sieve Analysis of Fine and Coarse Aggregates" or AASHTO PP 74 "Standard Practice for Determination of Size and Shape of Glass Beads Used in Traffic Markings by Means of Computerized Optical Method", a 50 g sample of the GTR shall conform to the following gradation requirements.

Sieve Size	Percent Passing
No. 16 (1.18 mm)	100
No. 30 (600 μm)	95 ± 5
No. 50 (300 μm)	> 20

GTR modified asphalt binder shall be tested for rotational viscosity according to AASHTO T 316 using spindle S27. GTR modified asphalt binder shall be tested for original dynamic shear and RTFO dynamic shear according to AASHTO T 315 using a gap of 2 mm.

The GTR modified asphalt binder shall meet the requirements of Table 3.

Table 3 - Requirements for Ground Tire Rubber (GTR) Modified Asphalt Binders		
Test	Asphalt Grade GTR PG 64-28 GTR PG 70-22	Asphalt Grade GTR PG 76-22 GTR PG 76-28 GTR PG 70-28
<b>TESTS ON RESIDUE FROM ROLLING THIN FILM OVEN TEST (AASHTO T 240)</b>		
Elastic Recovery ASTM D 6084, Procedure A, 77 °F (25 °C), 100 mm elongation, %	60 min.	70 min.

- (3) Softener Modification (SM). Softener modification is the addition of organic compounds, such as engineered flux, bio-oil blends, modified vegetable oils, glycol amines, and fatty acid derivatives, to the base asphalt binder to achieve the specified performance grade. Softeners shall be dissolved, dispersed, or reacted in the asphalt binder to enhance its performance and shall remain compatible with the asphalt binder with no separation. Softeners shall not be added to modified PG asphalt binder as defined in Articles 1032.05(b)(1) or 1032.05(b)(2).

An Attenuated Total Reflectance-Fourier Transform Infrared spectrum (ATR-FTIR) shall be collected for both the softening compound as well as the softener modified asphalt binder at the dose intended for qualification. The ATR-FTIR spectra shall be collected on unaged softener modified binder, 20-hour Pressurized Aging Vessel (PAV) aged softener modified binder, and 40-hour PAV aged softener modified binder. The ATR-FTIR shall be collected in accordance with Illinois Test Procedure 601. The electronic files spectral files (in one of the following extensions or equivalent: \*.SPA, \*.SPG, \*.IRD, \*.IFG, \*.CSV, \*.SP, \*.IRS, \*.GAML, \*. [0-9], \*.IGM, \*.ABS, \*.DRT, \*.SBM, \*.RAS) shall be submitted to the Central Bureau of Materials.

Softener modified asphalt binders shall meet the requirements in Table 4.

Table 4 - Requirements for Softener Modified Asphalt Binders		
Test	Asphalt Grade	
	SM PG 46-28	SM PG 46-34
	SM PG 52-28	SM PG 52-34
	SM PG 58-22	SM PG 58-28
	SM PG 64-22	
Small Strain Parameter (AASHTO PP 113) BBR, ΔT <sub>c</sub> , 40 hrs PAV (40 hrs continuous or 2 PAV at 20 hrs)	-5°C min.	
Large Strain Parameter (Illinois Modified AASHTO T 391) DSR/LAS Fatigue Property, Δ G*  <sub>peak</sub> τ, 40 hrs PAV (40 hrs continuous or 2 PAV at 20 hrs)	≥ 54 %	

The following grades may be specified as tack coats.

Asphalt Grade	Use
PG 58-22, PG 58-28, PG 64-22	Tack Coat"

Revise Article 1031.06(c)(1) and 1031.06(c)(2) of the Standard Specifications to read:

“(1) RAP/RAS. When RAP is used alone or RAP is used in conjunction with RAS, the percentage of virgin ABR shall not exceed the amounts listed in the following table.

HMA Mixtures - RAP/RAS Maximum ABR % <sup>1/ 2/</sup>			
Ndesign	Binder	Surface	Polymer Modified Binder or Surface <sup>3/</sup>
30	30	30	10
50	25	15	10
70	15	10	10
90	10	10	10

- 1/ For Low ESAL HMA shoulder and stabilized subbase, the RAP/RAS ABR shall not exceed 50 percent of the mixture.
- 2/ When RAP/RAS ABR exceeds 20 percent, the high and low virgin asphalt binder grades shall each be reduced by one grade (i.e. 25 percent ABR would require a virgin asphalt binder grade of PG 64-22 to be reduced to a PG 58-28).
- 3/ The maximum ABR percentages for ground tire rubber (GTR) modified mixes shall be equivalent to the percentages specified for SBS/SBR polymer modified mixes.

(2) FRAP/RAS. When FRAP is used alone or FRAP is used in conjunction with RAS, the percentage of virgin asphalt binder replacement shall not exceed the amounts listed in the following table.

HMA Mixtures - FRAP/RAS Maximum ABR % <sup>1/ 2/</sup>			
Ndesign	Binder	Surface	Polymer Modified Binder or Surface <sup>3/</sup>
30	55	45	15
50	45	40	15
70	45	35	15
90	45	35	15
SMA	--	--	25
IL-4.75	--	--	35

- 1/ For Low ESAL HMA shoulder and stabilized subbase, the FRAP/RAS ABR shall not exceed 50 percent of the mixture.
- 2/ When FRAP/RAS ABR exceeds 20 percent for all mixes, the high and low virgin asphalt binder grades shall each be reduced by one grade (i.e. 25 percent ABR would require a virgin asphalt binder grade of PG 64-22 to be reduced to a PG 58-28).
- 3/ The maximum ABR percentages for GTR modified mixes shall be equivalent to the percentages specified for SBS/SBR polymer modified mixes.”

Add the following to the end of Note 2 of Article 1030.03 of the Standard Specifications.

“A dedicated storage tank for the ground tire rubber (GTR) modified asphalt binder shall be provided. This tank shall be capable of providing continuous mechanical mixing throughout and/or recirculation of the asphalt binder to provide a uniform mixture. The tank shall be heated and capable of maintaining the temperature of the asphalt binder at 300 °F to 350 °F (149 °C to 177 °C). The asphalt binder metering systems of dryer drum plants shall be calibrated with the actual GTR modified asphalt binder material with an accuracy of  $\pm 0.40$  percent.”

## **PORTLAND CEMENT CONCRETE (BDE)**

Effective: August 1, 2023

Revise the second paragraph of Article 1103.03(a)(4) the Standard Specifications to read:

“The dispenser system shall provide a visual indication that the liquid admixture is actually entering the batch, such as via a transparent or translucent section of tubing or by independent check with an integrated secondary metering device. If approved by the Engineer, an alternate indicator may be used for admixtures dosed at rates of 25 oz/cwt (1630 mL/100 kg) or greater, such as accelerating admixtures, corrosion inhibitors, and viscosity modifying admixtures.”

## **PREFORMED PLASTIC PAVEMENT MARKING (BDE)**

Effective: June 2, 2024

Revise Article 1095.03(h) of the Standard Specifications to read:

“(h) Glass Beads. Glass beads shall be colorless and uniformly distributed throughout the yellow and white portions of the material only. A top coating of beads shall be bonded to or directly embedded into the surface of the markings such that the beads are not easily removed when the film is scratched firmly with a thumb nail.

The glass bead refractive index shall be tested using the liquid immersion method.

Type B material shall have an inner mix of glass beads with a minimum refractive index of 1.50 and a top coating of ceramic beads bonded to top urethane wear surface with a minimum refractive index of 1.70. Beads with a refractive index greater than 1.80 shall not be used.

Type C material shall have glass beads with a minimum refractive index of 1.50 and a layer of skid resistant ceramic particles bonded to the top urethane wear surface. The urethane wear surface shall have a nominal thickness of 5 mils (0.13 mm).”

Revise Article 1095.03(n) of the Standard Specifications to read:

“(n) Sampling and Inspection.

(1) Sample. Prior to approval and use of preformed plastic pavement markings, the manufacturer shall submit a notarized certification from an independent laboratory, together with the results of all tests, stating that the material meets the requirements as set forth herein. The independent laboratory test report shall state the lot tested, the manufacturer’s name, and the date of manufacture.

After initial approval by the Department, samples and certification by the manufacturer shall be submitted for each subsequent batch used. The manufacturer shall submit a certification stating that the material meets the requirements as set forth herein and is essentially identical to the material sent for qualification. The certification shall state the lot tested, the manufacturer’s name, and the date of manufacture.

(2) Inspection. The Contractor shall provide a manufacturer’s certification to the Engineer stating the material meets all requirements of this specification. All material samples for acceptance tests will be taken or witnessed by a representative of the Bureau of Materials and will be submitted to the Engineer of Materials, 126 East Ash Street, Springfield, Illinois 62704-4766 at least 30 days in advance of the pavement marking operations.”

## REMOVAL AND DISPOSAL OF REGULATED SUBSTANCES (BDE)

Effective: January 1, 2024

Revised: April 1, 2024

Revise the first paragraph of Article 669.04 of the Standard Specifications to read:

**“669.04 Regulated Substances Monitoring.** Regulated substances monitoring includes environmental observation and field screening during regulated substances management activities. The excavated soil and groundwater within the work areas shall be managed as either uncontaminated soil, hazardous waste, special waste, or non-special waste.

As part of the regulated substances monitoring, the monitoring personnel shall perform and document the applicable duties listed on form BDE 2732 “Regulated Substances Monitoring Daily Record (RSMDR)”.

Revise the first two sentences of the nineteenth paragraph of Article 669.05 of the Standard Specifications to read:

“The Contractor shall coordinate waste disposal approvals with the disposal facility and provide the specific analytical testing requirements of that facility. The Contractor shall make all arrangements for collection, transportation, and analysis of landfill acceptance testing.”

Revise the last paragraph of Article 669.05 of the Standard Specifications to read:

“The Contractor shall select a permitted landfill facility or CCDD/USFO facility meeting the requirements of 35 Ill. Admin. Code Parts 810-814 or Part 1100, respectively. The Department will review and approve or reject the facility proposed by the Contractor based upon information provided in BDE 2730. The Contractor shall verify whether the selected facility is compliant with those applicable standards as mandated by their permit and whether the facility is presently, has previously been, or has never been, on the United States Environmental Protection Agency (U.S. EPA) National Priorities List or the Resource Conservation and Recovery Act (RCRA) List of Violating Facilities. The use of a Contractor selected facility shall in no manner delay the construction schedule or alter the Contractor's responsibilities as set forth.”

Revise the first paragraph of Article 669.07 of the Standard Specifications to read:

**“669.07 Temporary Staging.** Soil classified according to Articles 669.05(a)(2), (b)(1), or (c) may be temporarily staged at the Contractor's option. All other soil classified according to Articles 669.05(a)(1), (a)(3), (a)(4), (a)(5), (a)(6), or (b)(2) shall be managed and disposed of without temporary staging to the greatest extent practicable. If circumstances beyond the Contractor's control require temporary staging of these latter materials, the Contractor shall request approval from the Engineer in writing.



Topsoil for re-use as final cover which has been field screened and found not to exhibit PID readings over daily background readings as documented on the BDE 2732, visual staining or odors, and is classified according to Articles 669.05(a)(2), (a)(3), (a)(4), (b)(1), or (c) may be temporarily staged at the Contractor's option."

Add the following paragraph after the sixth paragraph of Article 669.11 of the Standard Specifications.

"The sampling and testing of effluent water derived from dewatering discharges for priority pollutants volatile organic compounds (VOCs), priority pollutants semi-volatile organic compounds (SVOCs), or priority pollutants metals, will be paid for at the contract unit price per each for VOCS GROUNDWATER ANALYSIS using EPA Method 8260B, SVOCs GROUNDWATER ANALYSIS using EPA Method 8270C, or RCRA METALS GROUNDWATER ANALYSIS using EPA Methods 6010B and 7471A. This price shall include transporting the sample from the job site to the laboratory."

Revise the first sentence of the eight paragraph of Article 669.11 of the Standard Specifications to read:

"Payment for temporary staging of soil classified according to Articles 669.05(a)(1), (a)(3), (a)(4), (a)(5), (a)(6), or (b)(2) to be managed and disposed of, if required and approved by the Engineer, will be paid according to Article 109.04."

## **SEEDING (BDE)**

Effective: November 1, 2022

Revise Article 250.07 of the Standard Specifications to read:

**"250.07 Seeding Mixtures.** The classes of seeding mixtures and combinations of mixtures will be designated in the plans.

When an area is to be seeded with two or more seeding classes, those mixtures shall be applied separately on the designated area within a seven day period. Seeding shall occur prior to placement of mulch cover. A Class 7 mixture can be applied at any time prior to applying any seeding class or added to them and applied at the same time.

TABLE 1 - SEEDING MIXTURES		
Class - Type	Seeds	lb/acre (kg/hectare)
1 Lawn Mixture 1/	Kentucky Bluegrass	100 (110)
	Perennial Ryegrass	60 (70)
	<i>Festuca rubra</i> ssp. <i>rubra</i> (Creeping Red Fescue)	40 (50)
1A Salt Tolerant Lawn Mixture 1/	Kentucky Bluegrass	60 (70)
	Perennial Ryegrass	20 (20)
	<i>Festuca rubra</i> ssp. <i>rubra</i> (Creeping Red Fescue)	20 (20)
	<i>Festuca brevipilla</i> (Hard Fescue)	20 (20)
	<i>Puccinellia distans</i> (Fults Saltgrass or Salty Alkaligrass)	60 (70)
1B Low Maintenance Lawn Mixture 1/	Turf-Type Fine Fescue 3/	150 (170)
	Perennial Ryegrass	20 (20)
	Red Top	10 (10)
	<i>Festuca rubra</i> ssp. <i>rubra</i> (Creeping Red Fescue)	20 (20)
2 Roadside Mixture 1/	<i>Lolium arundinaceum</i> (Tall Fescue)	100 (110)
	Perennial Ryegrass	50 (55)
	<i>Festuca rubra</i> ssp. <i>rubra</i> (Creeping Red Fescue)	40 (50)
	Red Top	10 (10)
2A Salt Tolerant Roadside Mixture 1/	<i>Lolium arundinaceum</i> (Tall Fescue)	60 (70)
	Perennial Ryegrass	20 (20)
	<i>Festuca rubra</i> ssp. <i>rubra</i> (Creeping Red Fescue)	30 (20)
	<i>Festuca brevipilla</i> (Hard Fescue)	30 (20)
	<i>Puccinellia distans</i> (Fults Saltgrass or Salty Alkaligrass)	60 (70)
3 Northern Illinois Slope Mixture 1/	<i>Elymus canadensis</i> (Canada Wild Rye) 5/	5 (5)
	Perennial Ryegrass	20 (20)
	Alsike Clover 4/	5 (5)
	<i>Desmanthus illinoensis</i> (Illinois Bundleflower) 4/ 5/	2 (2)
	<i>Schizachyrium scoparium</i> (Little Bluestem) 5/	12 (12)
	<i>Bouteloua curtipendula</i> (Side-Oats Grama) 5/	10 (10)
	<i>Puccinellia distans</i> (Fults Saltgrass or Salty Alkaligrass)	30 (35)
	Oats, Spring	50 (55)
	Slender Wheat Grass 5/	15 (15)
	Buffalo Grass 5/ 7/	5 (5)
	3A Southern Illinois Slope Mixture 1/	Perennial Ryegrass
<i>Elymus canadensis</i> (Canada Wild Rye) 5/		20 (20)
<i>Panicum virgatum</i> (Switchgrass) 5/		10 (10)
<i>Schizachyrium scoparium</i> (Little Blue Stem) 5/		12 (12)
<i>Bouteloua curtipendula</i> (Side-Oats Grama) 5/		10 (10)
<i>Dalea candida</i> (White Prairie Clover) 4/ 5/		5 (5)
<i>Rudbeckia hirta</i> (Black-Eyed Susan) 5/		5 (5)
Oats, Spring		50 (55)

Class – Type	Seeds	lb/acre (kg/hectare)
4 Native Grass 2/ 6/	<i>Andropogon gerardi</i> (Big Blue Stem) 5/	4 (4)
	<i>Schizachyrium scoparium</i> (Little Blue Stem) 5/	5 (5)
	<i>Bouteloua curtipendula</i> (Side-Oats Grama) 5/	5 (5)
	<i>Elymus canadensis</i> (Canada Wild Rye) 5/	1 (1)
	<i>Panicum virgatum</i> (Switch Grass) 5/	1 (1)
	<i>Sorghastrum nutans</i> (Indian Grass) 5/	2 (2)
	Annual Ryegrass	25 (25)
	Oats, Spring	25 (25)
	Perennial Ryegrass	15 (15)
	4A Low Profile Native Grass 2/ 6/	<i>Schizachyrium scoparium</i> (Little Blue Stem) 5/
<i>Bouteloua curtipendula</i> (Side-Oats Grama) 5/		5 (5)
<i>Elymus canadensis</i> (Canada Wild Rye) 5/		1 (1)
<i>Sporobolus heterolepis</i> (Prairie Dropseed) 5/		0.5 (0.5)
Annual Ryegrass		25 (25)
Oats, Spring		25 (25)
Perennial Ryegrass		15 (15)
4B Wetland Grass and Sedge Mixture 2/ 6/		Annual Ryegrass
	Oats, Spring	25 (25)
	Wetland Grasses (species below) 5/	6 (6)
<u>Species:</u>	<u>% By Weight</u>	
<i>Calamagrostis canadensis</i> (Blue Joint Grass)	12	
<i>Carex lacustris</i> (Lake-Bank Sedge)	6	
<i>Carex slipata</i> (Awl-Fruited Sedge)	6	
<i>Carex stricta</i> (Tussock Sedge)	6	
<i>Carex vulpinoidea</i> (Fox Sedge)	6	
<i>Eleocharis acicularis</i> (Needle Spike Rush)	3	
<i>Eleocharis obtusa</i> (Blunt Spike Rush)	3	
<i>Glyceria striata</i> (Fowl Manna Grass)	14	
<i>Juncus effusus</i> (Common Rush)	6	
<i>Juncus tenuis</i> (Slender Rush)	6	
<i>Juncus torreyi</i> (Torrey's Rush)	6	
<i>Leersia oryzoides</i> (Rice Cut Grass)	10	
<i>Scirpus acutus</i> (Hard-Stemmed Bulrush)	3	
<i>Scirpus atrovirens</i> (Dark Green Rush)	3	
<i>Bolboschoenus fluviatilis</i> (River Bulrush)	3	
<i>Schoenoplectus tabernaemontani</i> (Softstem Bulrush)	3	
<i>Spartina pectinata</i> (Cord Grass)	4	

Class – Type	Seeds	lb/acre (kg/hectare)
5	Forb with	1 (1)
	Annuals Mixture (Below)	
	Annuals Mixture 2/ 5/ 6/	10 (10)
	Forb Mixture (Below)	
	Annuals Mixture - Mixture not exceeding 25 % by weight of any one species, of the following:	
	<i>Coreopsis lanceolata</i> (Sand Coreopsis)	
	<i>Leucanthemum maximum</i> (Shasta Daisy)	
	<i>Gaillardia pulchella</i> (Blanket Flower)	
	<i>Ratibida columnifera</i> (Prairie Coneflower)	
	<i>Rudbeckia hirta</i> (Black-Eyed Susan)	
	Forb Mixture - Mixture not exceeding 5 % by weight PLS of any one species, of the following:	
	<i>Amorpha canescens</i> (Lead Plant) 4/	
	<i>Anemone cylindrica</i> (Thimble Weed)	
	<i>Asclepias tuberosa</i> (Butterfly Weed)	
	<i>Aster azureus</i> (Sky Blue Aster)	
	<i>Symphotrichum leave</i> (Smooth Aster)	
	<i>Aster novae-angliae</i> (New England Aster)	
	<i>Baptisia leucantha</i> (White Wild Indigo) 4/	
	<i>Coreopsis palmata</i> (Prairie Coreopsis)	
	<i>Echinacea pallida</i> (Pale Purple Coneflower)	
	<i>Eryngium yuccifolium</i> (Rattlesnake Master)	
	<i>Helianthus mollis</i> (Downy Sunflower)	
	<i>Heliopsis helianthoides</i> (Ox-Eye)	
	<i>Liatris aspera</i> (Rough Blazing Star)	
	<i>Liatris pycnostachya</i> (Prairie Blazing Star)	
	<i>Monarda fistulosa</i> (Prairie Bergamot)	
	<i>Parthenium integrifolium</i> (Wild Quinine)	
	<i>Dalea candida</i> (White Prairie Clover) 4/	
	<i>Dalea purpurea</i> (Purple Prairie Clover) 4/	
	<i>Physostegia virginiana</i> (False Dragonhead)	
	<i>Potentilla arguta</i> (Prairie Cinquefoil)	
	<i>Ratibida pinnata</i> (Yellow Coneflower)	
	<i>Rudbeckia subtomentosa</i> (Fragrant Coneflower)	
	<i>Silphium laciniatum</i> (Compass Plant)	
	<i>Silphium terebinthinaceum</i> (Prairie Dock)	
	<i>Oligoneuron rigidum</i> (Rigid Goldenrod)	
	<i>Tradescantia ohiensis</i> (Spiderwort)	
	<i>Veronicastrum virginicum</i> (Culver's Root)	

Class – Type	Seeds	lb/acre (kg/hectare)
5A Large Flower Native Forb Mixture 2/ 5/ 6/	Forb Mixture (see below)	5 (5)
	<u>Species:</u>	<u>% By Weight</u>
	<i>Aster novae-angliae</i> (New England Aster)	5
	<i>Echinacea pallida</i> (Pale Purple Coneflower)	10
	<i>Helianthus mollis</i> (Downy Sunflower)	10
	<i>Heliopsis helianthoides</i> (Ox-Eye)	10
	<i>Liatris pycnostachya</i> (Prairie Blazing Star)	10
	<i>Ratibida pinnata</i> (Yellow Coneflower)	5
	<i>Rudbeckia hirta</i> (Black-Eyed Susan)	10
	<i>Silphium laciniatum</i> (Compass Plant)	10
	<i>Silphium terebinthinaceum</i> (Prairie Dock)	20
	<i>Oligoneuron rigidum</i> (Rigid Goldenrod)	10
5B Wetland Forb 2/ 5/ 6/	Forb Mixture (see below)	2 (2)
	<u>Species:</u>	<u>% By Weight</u>
	<i>Acorus calamus</i> (Sweet Flag)	3
	<i>Angelica atropurpurea</i> (Angelica)	6
	<i>Asclepias incarnata</i> (Swamp Milkweed)	2
	<i>Aster puniceus</i> (Purple Stemmed Aster)	10
	<i>Bidens cernua</i> (Beggarticks)	7
	<i>Eutrochium maculatum</i> (Spotted Joe Pye Weed)	7
	<i>Eupatorium perfoliatum</i> (Boneset)	7
	<i>Helenium autumnale</i> (Autumn Sneezeweed)	2
	<i>Iris virginica shrevei</i> (Blue Flag Iris)	2
	<i>Lobelia cardinalis</i> (Cardinal Flower)	5
	<i>Lobelia siphilitica</i> (Great Blue Lobelia)	5
	<i>Lythrum alatum</i> (Winged Loosestrife)	2
	<i>Physostegia virginiana</i> (False Dragonhead)	5
	<i>Persicaria pensylvanica</i> (Pennsylvania Smartweed)	10
	<i>Persicaria lapathifolia</i> (Curlytop Knotweed)	10
	<i>Pycnanthemum virginianum</i> (Mountain Mint)	5
	<i>Rudbeckia laciniata</i> (Cut-leaf Coneflower)	5
	<i>Oligoneuron riddellii</i> (Riddell Goldenrod)	2
	<i>Sparganium eurycarpum</i> (Giant Burreed)	5
6 Conservation Mixture 2/ 6/	<i>Schizachyrium scoparium</i> (Little Blue Stem) 5/ <i>Elymus canadensis</i> (Canada Wild Rye) 5/ Buffalo Grass 5/ 7/ Vernal Alfalfa 4/ Oats, Spring	5 (5) 2 (2) 5 (5) 15 (15) 48 (55)
6A Salt Tolerant Conservation Mixture 2/ 6/	<i>Schizachyrium scoparium</i> (Little Blue Stem) 5/ <i>Elymus canadensis</i> (Canada Wild Rye) 5/ Buffalo Grass 5/ 7/ Vernal Alfalfa 4/ Oats, Spring <i>Puccinellia distans</i> (Fults Saltgrass or Salty Alkaligrass)	5 (5) 2 (2) 5 (5) 15 (15) 48 (55) 20 (20)
7 Temporary Turf Cover Mixture	Perennial Ryegrass Oats, Spring	50 (55) 64 (70)

Notes:

- 1/ Seeding shall be performed when the ambient temperature has been between 45 °F (7 °C) and 80 °F (27 °C) for a minimum of seven (7) consecutive days and is forecasted to be the same for the next five (5) days according to the National Weather Service.
- 2/ Seeding shall be performed in late fall through spring beginning when the ambient temperature has been below 45 °F (7 °C) for a minimum of seven (7) consecutive days and ending when the ambient temperature exceeds 80 °F (27 °C) according to the National Weather Service.
- 3/ Specific variety as shown in the plans or approved by the Engineer.
- 4/ Inoculation required.
- 5/ Pure Live Seed (PLS) shall be used.
- 6/ Fertilizer shall not be used.
- 7/ Seed shall be primed with KNO<sub>3</sub> to break dormancy and dyed to indicate such.

Seeding will be inspected after a period of establishment. The period of establishment shall be six (6) months minimum, but not to exceed nine (9) months. After the period of establishment, areas not exhibiting 75 percent uniform growth shall be interseeded or reseeded, as determined by the Engineer, at no additional cost to the Department.”

**SHORT TERM AND TEMPORARY PAVEMENT MARKINGS (BDE)**

Effective: April 1, 2024

Revised: April 2, 2024

Revise Article 701.02(d) of the Standard Specifications to read:

“(d) Pavement Marking Tapes (Note 3) .....1095.06”

Add the following Note to the end of Article 701.02 of the Standard Specifications:

“Note 3. White or yellow pavement marking tape that is to remain in place longer than 14 days shall be Type IV tape.”

Revise Article 703.02(c) of the Standard Specifications to read:

“(c) Pavement Marking Tapes (Note 1) .....1095.06”

Add the following Note to the end of Article 703.02 of the Standard Specifications:

“Note 1. White or yellow pavement marking tape that is to remain in place longer than 14 days shall be Type IV tape.”

Revise Article 1095.06 of the Standard Specifications to read:

**1095.06 Pavement Marking Tapes.** Type I white or yellow marking tape shall consist of glass spheres embedded into a binder on a foil backing that is precoated with a pressure sensitive adhesive. The spheres shall be of uniform gradation and distributed evenly over the surface of the tape.

Type IV tape shall consist of white or yellow tape with wet reflective media incorporated to provide immediate and continuing retroreflection in wet and dry conditions. The wet retroreflective media shall be bonded to a durable polyurethane surface. The patterned surface shall have approximately 40 ± 10 percent of the surface area raised and presenting a near vertical face to traffic from any direction. The channels between the raised areas shall be substantially free of exposed reflective elements or particles.

Blackout tape shall consist of a matte black, non-reflective, patterned surface that is precoated with a pressure sensitive adhesive.

- (a) Color. The white and yellow markings shall meet the following requirements for daylight reflectance and color, when tested, using a color spectrophotometer with 45 degrees circumferential/zero degree geometry, illuminant D65, and two degree observer angle. The color instrument shall measure the visible spectrum from 380 to 720 nm with a wavelength measurement interval and spectral bandpass of 10 nm.

Color	Daylight Reflectance %Y
White	65 min.
Yellow *	36 - 59

\*Shall match Aerospace Material Specification Standard 595 33538 (Orange Yellow) and the chromaticity limits as follows.

x	0.490	0.475	0.485	0.530
y	0.470	0.438	0.425	0.456

- (b) Retroreflectivity. The white and yellow markings shall be retroreflective. Reflective values measured in accordance with the photometric testing procedure of ASTM D 4061 shall not be less than those listed in the table below. The coefficient of retroreflected luminance,  $R_L$ , shall be expressed as average millicandelas/footcandle/sq ft (millicandelas/lux/sq m), measured on a 3.0 x 0.5 ft (900 mm x 150 mm) panel at 86 degree entrance angle.

Coefficient of Retroreflected Luminance, $R_L$ , Dry					
Type I			Type IV		
Observation Angle	White	Yellow	Observation Angle	White	Yellow
0.2°	2700	2400	0.2°	1300	1200
0.5°	2250	2000	0.5°	1100	1000

Wet retroreflectance shall be measured for Type IV under wet conditions according to ASTM E 2177 and meet the following.

Wet Retroreflectance, Initial R <sub>L</sub>	
Color	R <sub>L</sub> 1.05/88.76
White	300
Yellow	200

- (c) Skid Resistance. The surface of Type IV and blackout markings shall provide a minimum skid resistance of 45 BPN when tested according to ASTM E 303.
- (d) Application. The pavement marking tape shall have a precoated pressure sensitive adhesive and shall require no activation procedures. Test pieces of the tape shall be applied according to the manufacturer's instructions and tested according to ASTM D 1000, Method A, except that a stiff, short bristle roller brush and heavy hand pressure will be substituted for the weighted rubber roller in applying the test pieces to the metal test panel. Material tested as directed above shall show a minimum adhesion value of 750 g/in. (30 g/mm) width at the temperatures specified in ASTM D 1000. The adhesive shall be resistant to oils, acids, solvents, and water, and shall not leave objectionable stains or residue after removal. The material shall be flexible and conformable to the texture of the pavement.
- (e) Durability. Type IV and blackout tape shall be capable of performing for the duration of a normal construction season and shall then be capable of being removed intact or in large sections at pavement temperatures above 40 °F (4 °C) either manually or with a roll-up device without the use of sandblasting, solvents, or grinding. The Contractor shall provide a manufacturer's certification that the material meets the requirements for being removed after the following minimum traffic exposure based on transverse test decks with rolling traffic.
  - (1) Time in place - 400 days
  - (2) ADT per lane - 9,000 (28 percent trucks)
  - (3) Axle hits - 10,000,000 minimum

Samples of the material applied to standard specimen plates will be measured for thickness and tested for durability in accordance with ASTM D 4060, using a CS-17 wheel and 1000-gram load, and shall meet the following criteria showing no significant change in color after being tested for the number of cycles indicated.

Test	Type I	Type IV	Blackout
Minimum Initial Thickness, mils (mm)	20 (0.51)	65 (1.65) <sup>1/</sup> 20 (0.51) <sup>2/</sup>	65 (1.65) <sup>1/</sup> 20 (0.51) <sup>2/</sup>
Durability (cycles)	5,000	1,500	1,500



- 1/ Measured at the thickest point of the patterned surface.
- 2/ Measured at the thinnest point of the patterned surface.

The pavement marking tape, when applied according to the manufacturer's recommended procedures, shall be weather resistant and shall show no appreciable fading, lifting, or shrinkage during the useful life of the marking. The tape, as applied, shall be of good appearance, free of cracks, and edges shall be true, straight, and unbroken.

(f) Sampling and Inspection.

- (1) Sample. Prior to approval and use of Type IV pavement marking tape, the manufacturer shall submit a notarized certification from an independent laboratory, together with the results of all tests, stating that the material meets the requirements as set forth herein. The independent laboratory test report shall state the lot tested, the manufacturer's name, and the date of manufacture.

After initial approval by the Department, samples and certification by the manufacturer shall be submitted for each subsequent batch of Type IV tape used. The manufacturer shall submit a certification stating that the material meets the requirements as set forth herein and is essentially identical to the material sent for qualification. The certification shall state the lot tested, the manufacturer's name, and the date of manufacture.

- (2) Inspection. The Contractor shall provide a manufacturer's certification to the Engineer stating the material meets all requirements of this specification. All material samples for acceptance tests shall be taken or witnessed by a representative of the Bureau of Materials and shall be submitted to the Engineer of Materials, 126 East Ash Street, Springfield, Illinois 62704-4766 at least 30 days in advance of the pavement marking operations."

## **SOURCE OF SUPPLY AND QUALITY REQUIREMENTS (BDE)**

Effective: January 2, 2023

Add the following to Article 106.01 of the Standard Specifications:

“The final manufacturing process for construction materials and the immediately preceding manufacturing stage for construction materials shall occur within the United States. Construction materials shall include an article, material, or supply that is or consists primarily of the following.

- (a) Non-ferrous metals;
- (b) Plastic and polymer-based products (including polyvinylchloride, composite building materials, and polymers used in fiber optic cables);
- (c) Glass (including optic glass);
- (d) Lumber;
- (e) Drywall.

Items consisting of two or more of the listed construction materials that have been combined through a manufacturing process, and items including at least one of the listed materials combined with a material that is not listed through a manufacturing process shall be exempt.”

## **STEEL COST ADJUSTMENT (BDE)**

Effective: April 2, 2004

Revised: January 1, 2022

Description. Steel cost adjustments will be made to provide additional compensation to the Contractor, or a credit to the Department, for fluctuations in steel prices when optioned by the Contractor. The bidder shall indicate with their bid whether or not this special provision will be part of the contract. Failure to indicate “Yes” for any item of work will make that item of steel exempt from steel cost adjustment.

Types of Steel Products. An adjustment will be made for fluctuations in the cost of steel used in the manufacture of the following items:

- Metal Piling (excluding temporary sheet piling)
- Structural Steel
- Reinforcing Steel

Other steel materials such as dowel bars, tie bars, welded reinforcement, guardrail, steel traffic signal and light poles, towers and mast arms, metal railings (excluding wire fence), and frames and grates will be subject to a steel cost adjustment when the pay items they are used in have a contract value of \$10,000 or greater.

The adjustments shall apply to the above items when they are part of the original proposed construction, or added as extra work and paid for by agreed unit prices. The adjustments shall not apply when the item is added as extra work and paid for at a lump sum price or by force account.

Documentation. Sufficient documentation shall be furnished to the Engineer to verify the following:

- (a) The dates and quantity of steel, in lb (kg), shipped from the mill to the fabricator.
- (b) The quantity of steel, in lb (kg), incorporated into the various items of work covered by this special provision. The Department reserves the right to verify submitted quantities.

Method of Adjustment. Steel cost adjustments will be computed as follows:

$$SCA = Q \times D$$

Where: SCA = steel cost adjustment, in dollars  
Q = quantity of steel incorporated into the work, in lb (kg)  
D = price factor, in dollars per lb (kg)

$$D = MPI_M - MPI_L$$

Where:  $MPI_M$  = The Materials Cost Index for steel as published by the Engineering News-Record for the month the steel is shipped from the mill. The indices will be converted from dollars per 100 lb to dollars per lb (kg).

$MPI_L$  = The Materials Cost Index for steel as published by the Engineering News-Record for the month prior to the letting for work paid for at the contract price; or for the month the agreed unit price letter is submitted by the Contractor for extra work paid for by agreed unit price,. The indices will be converted from dollars per 100 lb to dollars per lb (kg).

The unit weights (masses) of steel that will be used to calculate the steel cost adjustment for the various items are shown in the attached table.

No steel cost adjustment will be made for any products manufactured from steel having a mill shipping date prior to the letting date.

If the Contractor fails to provide the required documentation, the method of adjustment will be calculated as described above; however, the  $MPI_M$  will be based on the date the steel arrives at the job site. In this case, an adjustment will only be made when there is a decrease in steel costs.

Basis of Payment. Steel cost adjustments may be positive or negative but will only be made when there is a difference between the  $MPI_L$  and  $MPI_M$  in excess of five percent, as calculated by:

$$\text{Percent Difference} = \{(MPI_L - MPI_M) \div MPI_L\} \times 100$$

Steel cost adjustments will be calculated by the Engineer and will be paid or deducted when all other contract requirements for the items of work are satisfied. Adjustments will only be made for fluctuations in the cost of the steel as described herein. No adjustment will be made for changes in the cost of manufacturing, fabrication, shipping, storage, etc.

The adjustments shall not apply during contract time subject to liquidated damages for completion of the entire contract.

**Attachment**

Item	Unit Mass (Weight)
Metal Piling (excluding temporary sheet piling)	
Furnishing Metal Pile Shells 12 in. (305 mm), 0.179 in. (3.80 mm) wall thickness)	23 lb/ft (34 kg/m)
Furnishing Metal Pile Shells 12 in. (305 mm), 0.250 in. (6.35 mm) wall thickness)	32 lb/ft (48 kg/m)
Furnishing Metal Pile Shells 14 in. (356 mm), 0.250 in. (6.35 mm) wall thickness)	37 lb/ft (55 kg/m)
Other piling	See plans
Structural Steel	See plans for weights (masses)
Reinforcing Steel	See plans for weights (masses)
Dowel Bars and Tie Bars	6 lb (3 kg) each
Welded Reinforcement	63 lb/100 sq ft (310 kg/sq m)
Guardrail	
Steel Plate Beam Guardrail, Type A w/steel posts	20 lb/ft (30 kg/m)
Steel Plate Beam Guardrail, Type B w/steel posts	30 lb/ft (45 kg/m)
Steel Plate Beam Guardrail, Types A and B w/wood posts	8 lb/ft (12 kg/m)
Steel Plate Beam Guardrail, Type 2	305 lb (140 kg) each
Steel Plate Beam Guardrail, Type 6	1260 lb (570 kg) each
Traffic Barrier Terminal, Type 1 Special (Tangent)	730 lb (330 kg) each
Traffic Barrier Terminal, Type 1 Special (Flared)	410 lb (185 kg) each
Steel Traffic Signal and Light Poles, Towers and Mast Arms	
Traffic Signal Post	11 lb/ft (16 kg/m)
Light Pole, Tenon Mount and Twin Mount, 30 - 40 ft (9 – 12 m)	14 lb/ft (21 kg/m)
Light Pole, Tenon Mount and Twin Mount, 45 - 55 ft (13.5 – 16.5 m)	21 lb/ft (31 kg/m)
Light Pole w/Mast Arm, 30 - 50 ft (9 – 15.2 m)	13 lb/ft (19 kg/m)
Light Pole w/Mast Arm, 55 - 60 ft (16.5 – 18 m)	19 lb/ft (28 kg/m)
Light Tower w/Luminaire Mount, 80 - 110 ft (24 – 33.5 m)	31 lb/ft (46 kg/m)
Light Tower w/Luminaire Mount, 120 - 140 ft (36.5 – 42.5 m)	65 lb/ft (97 kg/m)
Light Tower w/Luminaire Mount, 150 - 160 ft (45.5 – 48.5 m)	80 lb/ft (119 kg/m)
Metal Railings (excluding wire fence)	
Steel Railing, Type SM	64 lb/ft (95 kg/m)
Steel Railing, Type S-1	39 lb/ft (58 kg/m)
Steel Railing, Type T-1	53 lb/ft (79 kg/m)
Steel Bridge Rail	52 lb/ft (77 kg/m)
Frames and Grates	
Frame	250 lb (115 kg)
Lids and Grates	150 lb (70 kg)

**SUBCONTRACTOR AND DBE PAYMENT REPORTING (BDE)**

Effective: April 2, 2018

Add the following to Section 109 of the Standard Specifications.

**“109.14 Subcontractor and Disadvantaged Business Enterprise Payment Reporting.**  
 The Contractor shall report all payments made to the following parties:

- (a) first tier subcontractors;
- (b) lower tier subcontractors affecting disadvantaged business enterprise (DBE) goal credit;
- (c) material suppliers or trucking firms that are part of the Contractor’s submitted DBE utilization plan.

The report shall be made through the Department’s on-line subcontractor payment reporting system within 21 days of making the payment.”

**SUBCONTRACTOR MOBILIZATION PAYMENTS (BDE)**

Effective: November 2, 2017

Revised: April 1, 2019

Replace the second paragraph of Article 109.12 of the Standard Specifications with the following:

“This mobilization payment shall be made at least seven days prior to the subcontractor starting work. The amount paid shall be at the following percentage of the amount of the subcontract reported on form BC 260A submitted for the approval of the subcontractor’s work.

Value of Subcontract Reported on Form BC 260A	Mobilization Percentage
Less than \$10,000	25%
\$10,000 to less than \$20,000	20%
\$20,000 to less than \$40,000	18%
\$40,000 to less than \$60,000	16%
\$60,000 to less than \$80,000	14%
\$80,000 to less than \$100,000	12%
\$100,000 to less than \$250,000	10%
\$250,000 to less than \$500,000	9%
\$500,000 to \$750,000	8%
Over \$750,000	7%”

## **SUBMISSION OF PAYROLL RECORDS (BDE)**

Effective: April 1, 2021

Revised: November 2, 2023

FEDERAL AID CONTRACTS. Revise the following section of Check Sheet #1 of the Recurring Special Provisions to read:

### **“STATEMENTS AND PAYROLLS**

The payroll records shall include the worker’s name, social security number, last known address, telephone number, email address, classification(s) of work actually performed, hourly rates of wages paid (including rates of contributions or costs anticipated for bona fide fringe benefits or cash equivalents thereof), daily and weekly number of hours actually worked in total, deductions made, and actual wages paid.

The Contractor and each subcontractor shall submit certified payroll records to the Department each week from the start to the completion of their respective work, except that full social security numbers, last known addresses, telephone numbers, and email addresses shall not be included on weekly submittals. Instead, the payrolls need only include an identification number for each employee (e.g., the last four digits of the employee’s social security number). The submittals shall be made using LCPTracker Pro software. The software is web-based and can be accessed at <https://lcptracker.com/>. When there has been no activity during a work week, a payroll record shall still be submitted with the appropriate option (“No Work”, “Suspended”, or “Complete”) selected.”

STATE CONTRACTS. Revise Item 3 of Section IV of Check Sheet #5 of the Recurring Special Provisions to read:

- “3. Submission of Payroll Records. The Contractor and each subcontractor shall, no later than the 15<sup>th</sup> day of each calendar month, file a certified payroll for the immediately preceding month to the Illinois Department of Labor (IDOL) through the Illinois Prevailing Wage Portal in compliance with the State Prevailing Wage Act (820 ILCS 130). The portal can be found on the IDOL website at <https://www2.illinois.gov/idol/Laws-Rules/CONMED/Pages/Prevailing-Wage-Portal.aspx>. Payrolls shall be submitted in the format prescribed by the IDOL.

In addition to filing certified payroll(s) with the IDOL, the Contractor and each subcontractor shall certify and submit payroll records to the Department each week from the start to the completion of their respective work, except that full social security numbers shall not be included on weekly submittals. Instead, the payrolls shall include an identification number for each employee (e.g., the last four digits of the employee’s social security number). In addition, starting and ending times of work each day may be omitted from the payroll records submitted. The submittals shall be made using LCPTracker Pro software. The software is web-based and can be accessed at <https://lcptracker.com/>. When there has been no activity during a work week, a payroll record shall still be submitted with the appropriate option (“No Work”, “Suspended”, or “Complete”) selected.”

## **SURFACE TESTING OF PAVEMENTS – IRI (BDE)**

Effective: January 1, 2021

Revised: January 1, 2023

Description. This work shall consist of testing the ride quality of the finished surface of pavement sections with new concrete pavement, PCC overlays, full-depth HMA, and HMA overlays with at least 2.25 in. (57 mm) total thickness of new HMA combined with either HMA binder or HMA surface removal, according to Illinois Test Procedure 701, "Ride Quality Testing Using the International Roughness Index (IRI)". Work shall be according to Sections 406, 407, or 420 of the Standard Specifications, except as modified herein.

### **Hot-Mix Asphalt (HMA) Overlays**

Add the following to Article 406.03 of the Standard Specifications:

"(n) Pavement Surface Grinding Equipment..... 1101.04"

Revise Article 406.11 of the Standard Specifications to read:

**"406.11 Surface Tests.** Prior to HMA overlay pavement improvements, the Engineer will measure the smoothness of the existing high-speed mainline pavement. The Contractor shall measure the smoothness of the finished high-speed mainline, low-speed mainline, and miscellaneous pavements after the pavement improvement is complete but within the same construction season. Testing shall be performed in the presence of the Engineer and according to Illinois Test Procedure 701. The pavement will be identified as high-speed mainline, low-speed mainline, or miscellaneous as follows.

(a) Test Sections.

- (1) High-Speed Mainline Pavement. High-speed mainline pavement consists of pavements, ramps, and loops with a posted speed limit greater than 45 mph. These sections shall be tested with an inertial profiling system (IPS).
- (2) Low-Speed Mainline Pavement. Low-speed mainline pavement consists of pavements, ramps, and loops with a posted speed limit of 45 mph or less. These sections shall be tested using a 16 ft (5 m) straightedge or with an IPS analyzed using the rolling 16 ft (5 m) straightedge simulation in ProVAL.
- (3) Miscellaneous Pavement. Miscellaneous pavement are segments that either cannot readily be tested by an IPS or conditions beyond the control of the Contractor preclude the achievement of smoothness levels typically achievable with mainline pavement construction. This may include the following examples or as determined by the Engineer.



- a. Pavement on horizontal curves with a centerline radius of curvature of less than or equal to 1,000 ft (300 m) and the pavement within the superelevation transition of such curves;
- b. Pavement on vertical curves having a length less than or equal to 200 ft (60 m) in combination with an algebraic change in tangent grade greater than or equal to 3 percent as may occur on urban ramps or other constricted-space facilities;
- c. The first and last 50 ft (15 m) of a pavement section where the Contractor is not responsible for the adjoining surface;
- d. Intersections and the 25 ft (7.6 m) before and after an intersection or end of radius return;
- e. Variable width pavements;
- f. Side street returns, to the end of radius return;
- g. Crossovers;
- h. Pavement connector for bridge approach slab;
- i. Bridge approach slab;
- j. Pavement that must be constructed in segments of 600 ft (180 m) or less;
- k. Pavement within 25 ft (7.6 m) of manholes, utility structures, at-grade railroad crossings, or other appurtenances;
- l. Turn lanes; and
- m. Pavement within 5 ft (1.5 m) of jobsite sampling locations for HMA volumetric testing that fall within the wheel path.

Miscellaneous pavement shall be tested using a 16 ft (5 m) straightedge.

- (4) International Roughness Index (IRI). An index computed from a longitudinal profile measurement using a quarter-car simulation at a simulation speed of 50 mph (80 km/h).

- (5) Mean Roughness Index (MRI). The average of the IRI values for the right and left wheel tracks.
    - a.  $MRI_o$ . The MRI of the existing pavement prior to construction.
    - b.  $MRI_i$ . The MRI value that warrants an incentive payment.
    - c.  $MRI_f$ . The MRI value that warrants full payment.
    - d.  $MRI_D$ . The MRI value that warrants a financial disincentive.
  - (6) Areas of Localized Roughness (ALR). Isolated areas of roughness, which can cause significant increase in the calculated MRI for a given subplot.
  - (7) Sublot. A continuous strip of pavement 0.1 mile (160 m) long and one lane wide. A partial subplot greater than or equal to 264 ft (80 m) will be subject to the same evaluation as a whole subplot. Partial sublots less than 264 ft (80 m) shall be included with the previous subplot for evaluation purposes.
- (b) Corrective Work. Corrective work shall be completed according to the following.
- (1) High-Speed Mainline Pavement. For high-speed mainline pavement, any 25 ft (7.6 m) interval with an ALR in excess of 200 in./mile (3,200 mm/km) will be identified by the Engineer and shall be corrected by the Contractor. Any subplot having a MRI greater than  $MRI_D$ , including ALR, shall be corrected to reduce the MRI to the  $MRI_f$ , or replaced at the Contractor's option.
  - (2) Low-Speed Mainline Pavement. Surface variations in low-speed mainline pavement which exceed the 5/16 in. (8 mm) tolerance will be identified by the Engineer and shall be corrected by the Contractor.
  - (3) Miscellaneous Pavements. Surface variations in miscellaneous pavement which exceed the 5/16 in. (8 mm) tolerance will be identified by the Engineer and shall be corrected by the Contractor.

Corrective work shall be completed with pavement surface grinding equipment or by removing and replacing the pavement. Corrective work shall be applied to the full lane width. When completed, the corrected area shall have uniform texture and appearance, with the beginning and ending of the corrected area perpendicular to the centerline of the paved surface.

Upon completion of the corrective work, the surface of the subplot(s) shall be retested. The Contractor shall furnish the data and reports to the Engineer within 2 working days after corrections are made. If the MRI and/or ALR still do not meet the requirements, additional corrective work shall be performed.

Corrective work shall be at no additional cost to the Department.

(c) Smoothness Assessments. Assessments will be paid to or deducted from the Contractor for each subplot of high-speed mainline pavement per the Smoothness Assessment Schedule. Assessments will be based on the MRI of each subplot prior to performing any corrective work unless the Contractor has chosen to remove and replace the pavement. For pavement that is replaced, assessments will be based on the MRI determined after replacement.

The upper MRI thresholds for high-speed mainline pavement are dependent on the MRI of the existing pavement before construction ( $MRI_0$ ) and shall be determined as follows.

Upper MRI Thresholds <sup>1/</sup>	MRI Thresholds (High-Speed, HMA Overlay)	
	$MRI_0 \leq 125.0$ in./mile ( $\leq 1,975$ mm/km)	$MRI_0 > 125.0$ in./mile <sup>1/</sup> ( $> 1,975$ mm/km)
Incentive ( $MRI_I$ )	45.0 in./mile (710 mm/km)	$0.2 \times MRI_0 + 20$
Full Pay ( $MRI_F$ )	75.0 in./mile (1,190 mm/km)	$0.2 \times MRI_0 + 50$
Disincentive ( $MRI_D$ )	100.0 in./mile (1,975 mm/km)	$0.2 \times MRI_0 + 75$

1/  $MRI_0$ ,  $MRI_I$ ,  $MRI_F$ , and  $MRI_D$  shall be in in./mile for calculation.

Smoothness assessments for high-speed mainline pavement shall be determined as follows.

SMOOTHNESS ASSESSMENT SCHEDULE (High-Speed, HMA Overlay)	
Mainline Pavement MRI Range	Assessment Per Subplot <sup>1/</sup>
$MRI \leq MRI_I$	$+ (MRI_I - MRI) \times \$20.00$ <sup>2/</sup>
$MRI_I < MRI \leq MRI_F$	$+ \$0.00$
$MRI_F < MRI \leq MRI_D$	$- (MRI - MRI_F) \times \$8.00$
$MRI > MRI_D$	$- \$200.00$

1/  $MRI$ ,  $MRI_I$ ,  $MRI_F$ , and  $MRI_D$  shall be in in./mile for calculation.

2/ The maximum incentive amount shall not exceed \$300.00.

Smoothness assessments will not be paid or deducted until all other contract requirements for the pavement are satisfied. Pavement that is corrected or replaced for reasons other than smoothness, shall be retested as stated herein.”

**Hot-Mix Asphalt (HMA) Pavement (Full-Depth)**

Revise the first paragraph of Article 407.03 of the Standard Specifications to read:

**“407.03 Equipment.** Equipment shall be according to Article 406.03.”

Revise Article 407.09 of the Standard Specifications to read:

**“407.09 Surface Tests.** The finished surface of the pavement shall be tested for smoothness according to Article 406.11, except as follows:

The testing of the existing pavement prior to improvements shall not apply and the smoothness assessment for high-speed mainline pavement shall be determined according to the following table.

SMOOTHNESS ASSESSMENT SCHEDULE (High-Speed, Full-Depth HMA)	
Mainline Pavement MRI, in./mile (mm/km)	Assessment Per Sublot <sup>1/</sup>
≤ 45.0 (710)	+ (45 – MRI) × \$45.00 <sup>2/</sup>
> 45.0 (710) to 75.0 (1,190)	+ \$0.00
> 75.0 (1,190) to 100.0 (1,580)	– (MRI – 75) × \$20.00
> 100.0 (1,580)	– \$500.00

1/ MRI shall be in in./mile for calculation.

2/ The maximum incentive amount shall not exceed \$800.00.”

**Portland Cement Concrete Pavement**

Delete Article 420.03(i) of the Standard Specifications.

Revise Article 420.10 of the Standard Specifications to read:

**“420.10 Surface Tests.** The finished surface of the pavement shall be tested for smoothness according to Article 406.11, except as follows.

The testing of the existing pavement prior to improvements shall not apply. The Contractor shall measure the smoothness of the finished surface of the pavement after the pavement has attained a flexural strength of 250 psi (3,800 kPa) or a compressive strength of 1,600 psi (20,700 kPa).

Membrane curing damaged during testing shall be repaired as directed by the Engineer at no additional cost to the Department.

- (a) Corrective Work. No further texturing for skid resistance will be required for areas corrected by grinding. Protective coat shall be reapplied to areas ground according to Article 420.18 at no additional cost to the Department.

Jointed portland cement concrete pavement corrected by removal and replacement, shall be corrected in full panel sizes.

- (b) Smoothness Assessments. Smoothness assessment for high-speed mainline pavement shall be determined as follows.

SMOOTHNESS ASSESSMENT SCHEDULE (High-Speed, PCC)	
Mainline Pavement MRI, in./mile (mm/km) <sup>3/</sup>	Assessment Per Sublot <sup>1/</sup>
≤ 45.0 (710)	+ (45 – MRI) × \$60.00 <sup>2/</sup>
> 45.0 (710) to 75.0 (1,190)	+ \$0.00
> 75.0 (1,190) to 100.0 (1,580)	– (MRI – 75) × \$37.50
> 100.0 (1,580)	– \$750.00

1/ MRI shall be in in./mile for calculation.

2/ The maximum incentive amount shall not exceed \$1200.00.

3/ If pavement is constructed with traffic in the lane next to it, then an additional 10 in./mile will be added to the upper thresholds.”

**Removal of Existing Pavement and Appurtenances**

Revise the first paragraph of Article 440.04 of the Standard Specifications to read:

**“440.04 HMA Surface Removal for Subsequent Resurfacing.** The existing HMA surface shall be removed to the depth specified on the plans with a self-propelled milling machine. The removal depth may be varied slightly at the discretion of the Engineer to satisfy the smoothness requirements of the finished pavement. The temperature at which the work is performed, the nature and condition of the equipment, and the manner of performing the work shall be such that the milled surface is not torn, gouged, shoved or otherwise damaged by the milling operation. Sufficient cutting passes shall be made so that all irregularities or high spots are eliminated to the satisfaction of the Engineer. When tested with a 16 ft (5 m) straightedge, the milled surface shall have no surface variations in excess of 3/16 in. (5 mm).”

### **General Equipment**

Revise Article 1101.04 of the Standard Specifications to read:

**“1101.04 Pavement Surface Grinding Equipment.** The pavement surface grinding device shall have a minimum effective head width of 3 ft (0.9 m).

- (a) Diamond Saw Blade Machine. The machine shall be self-propelled with multiple diamond saw blades.
- (b) Profile Milling Machine. The profile milling machine shall be a drum device with carbide or diamond teeth with spacing of 0.315 in. (8 mm) or less and maintain proper forward speed for surface texture according to the manufacturer’s specifications.”

### **TRAFFIC SPOTTERS (BDE)**

Effective: January 1, 2019

Revise Article 701.13 of the Standard Specifications to read:

**“701.13 Flaggers and Spotters.** Flaggers shall be certified by an agency approved by the Department. While on the job site, each flagger shall have in his/her possession a current driver’s license and a current flagger certification I.D. card. For non-drivers, the Illinois Identification Card issued by the Secretary of State will meet the requirement for a current driver’s license. This certification requirement may be waived by the Engineer for emergency situations that arise due to actions beyond the Contractor’s control where flagging is needed to maintain safe traffic control on a temporary basis. Spotters are defined as certified flaggers that provide support to workers by monitoring traffic.

Flaggers and spotters shall be stationed to the satisfaction of the Engineer and be equipped with a fluorescent orange, fluorescent yellow/green, or a combination of fluorescent orange and fluorescent yellow/green vest meeting the requirements of ANSI/ISEA 107-2004 or ANSI/ISEA 107-2010 for Conspicuity Class 2 garments. Flaggers shall be equipped with a stop/slow traffic control sign. Spotters shall be equipped with a loud warning device. The warning sound shall be identifiable by workers so they can take evasive action when necessary. Other types of garments may be substituted for the vest as long as the garments have a manufacturer’s tag identifying them as meeting the ANSI Class 2 requirement. The longitudinal placement of the flagger may be increased up to 100 ft (30 m) from that shown on the plans to improve the visibility of the flagger. Flaggers shall not encroach on the open lane of traffic unless traffic has been stopped. Spotters shall not encroach on the open lane of traffic, nor interact with or control the flow of traffic.

For nighttime flagging, flaggers shall be illuminated by an overhead light source providing a minimum vertical illuminance of 10 fc (108 lux) measured 1 ft (300 mm) out from the flagger's chest. The bottom of any luminaire shall be a minimum of 10 ft (3 m) above the pavement. Luminaire(s) shall be shielded to minimize glare to approaching traffic and trespass light to adjoining properties. Nighttime flaggers shall be equipped with fluorescent orange or fluorescent orange and fluorescent yellow/green apparel meeting the requirements of ANSI/ISEA 107-2004 or ANSI/ISEA 107-2010 for Conspicuity Class 3 garments.

Flaggers and spotters shall be provided per the traffic control plan and as follows.

- (a) Two-Lane Highways. Two flaggers will be required for each separate operation where two-way traffic is maintained over one lane of pavement. Work operations controlled by flaggers shall be no more than 1 mile (1600 m) in length. Flaggers shall be in sight of each other or in direct communication at all times. Direct communication shall be obtained by using portable two-way radios or walkie-talkies.

The Engineer will determine when a side road or entrance shall be closed to traffic. A flagger will be required at each side road or entrance remaining open to traffic within the operation where two-way traffic is maintained on one lane of pavement. The flagger shall be positioned as shown on the plans or as directed by the Engineer.

- (b) Multi-Lane Highways. At all times where traffic is restricted to less than the normal number of lanes on a multilane pavement with a posted speed limit greater than 40 mph and the workers are present, but not separated from the traffic by physical barriers, a flagger or spotter shall be furnished as shown on the plans. Flaggers shall warn and direct traffic. Spotters shall monitor traffic conditions and warn workers of errant approaching vehicles or other hazardous conditions as they occur. One flagger will be required for each separate activity of an operation that requires frequent encroachment in a lane open to traffic. One spotter will be required for each separate activity with workers near the edge of the open lane or with their backs facing traffic.

Flaggers will not be required when no work is being performed, unless there is a lane closure on two-lane, two-way pavement.”

## **TRAINING SPECIAL PROVISIONS (BDE)**

Effective: October 15, 1975

Revised: September 2, 2021

This Training Special Provision supersedes Section 7b of the Special Provision entitled "Specific Equal Employment Opportunity Responsibilities," and is in implementation of 23 U.S.C. 140(a).

As part of the Contractor's equal employment opportunity affirmative action program, training shall be provided as follows:

The Contractor shall provide on-the-job training aimed at developing full journeyman in the type of trade or job classification involved. The number of trainees to be trained under this contract will be 3. In the event the Contractor subcontracts a portion of the contract work, it shall determine how many, if any, of the trainees are to be trained by the subcontractor, provided however, that the Contractor shall retain the primary responsibility for meeting the training requirements imposed by this special provision. The Contractor shall also ensure that this Training Special Provision is made applicable to such subcontract. Where feasible, 25 percent of apprentices or trainees in each occupation shall be in their first year of apprenticeship or training.

The number of trainees shall be distributed among the work classifications on the basis of the Contractor's needs and the availability of journeymen in the various classifications within the reasonable area of recruitment. Prior to commencing construction, the Contractor shall submit to the Illinois Department of Transportation for approval the number of trainees to be trained in each selected classification and training program to be used. Furthermore, the Contractor shall specify the starting time for training in each of the classifications. The Contractor will be credited for each trainee it employs on the contract work who is currently enrolled or becomes enrolled in an approved program and will be reimbursed for such trainees as provided hereinafter.

Training and upgrading of minorities and women toward journeyman status is a primary objective of this Training Special Provision. Accordingly, the Contractor shall make every effort to enroll minority trainees and women (e.g. by conducting systematic and direct recruitment through public and private sources likely to yield minority and women trainees) to the extent such persons are available within a reasonable area of recruitment. The Contractor will be responsible for demonstrating the steps it has taken in pursuance thereof, prior to a determination as to whether the Contractor is in compliance with this Training Special Provision. This training commitment is not intended, and shall not be used, to discriminate against any applicant for training, whether a member of a minority group or not.

No employee shall be employed as a trainee in any classification in which he or she has successfully completed a training course leading to journeyman status or in which he or she has been employed as a journeyman. The Contractor should satisfy this requirement by including appropriate questions in the employee application or by other suitable means. Regardless of the method used, the Contractor's records should document the findings in each case.



The minimum length and type of training for each classification will be as established in the training program selected by the Contractor and approved by the Illinois Department of Transportation and the Federal Highway Administration. The Illinois Department of Transportation and the Federal Highway Administration shall approve a program, if it is reasonably calculated to meet the equal employment opportunity obligations of the Contractor and to qualify the average trainee for journeyman status in the classification concerned by the end of the training period. Furthermore, apprenticeship programs registered with the U.S. Department of Labor, Bureau of Apprenticeship and Training, or with a State apprenticeship agency recognized by the Bureau and training programs approved by not necessarily sponsored by the U.S. Department of Labor Employment Training Administration shall also be considered acceptable provided it is being administered in a manner consistent with the equal employment obligations of Federal-aid highway construction contracts. Approval or acceptance of a training program shall be obtained from the State prior to commencing work on the classification covered by the program. It is the intention of these provisions that training is to be provided in the construction crafts rather than clerk-typists or secretarial-type positions. Training is permissible in lower level management positions such as office engineers, estimators, timekeepers, etc., where the training is oriented toward construction applications. Training in the laborer classification may be permitted provided that significant and meaningful training is provided and approved by the Illinois Department of Transportation and the Federal Highway Administration. Some offsite training is permissible as long as the training is an integral part of an approved training program and does not comprise a significant part of the overall training.

Except as otherwise noted below, the Contractor will be reimbursed 80 cents per hour of training given an employee on this contract in accordance with an approved training program. As approved by the Engineer, reimbursement will be made for training of persons in excess of the number specified herein. This reimbursement will be made even though the Contractor receives additional training program funds from other sources, provided such other source does not specifically prohibit the Contractor from receiving other reimbursement. Reimbursement for offsite training indicated above may only be made to the Contractor where he does one or more of the following and the trainees are concurrently employed on a Federal-aid project; contributes to the cost of the training, provides the instruction to the trainee or pays the trainee's wages during the offsite training period.

No payment shall be made to the Contractor if either the failure to provide the required training, or the failure to hire the trainee as a journeyman, is caused by the Contractor and evidences a lack of good faith on the part of the Contractor in meeting the requirement of this Training Special Provision. It is normally expected that a trainee will begin his training on the project as soon as feasible after start of work utilizing the skill involved and remain on the project as long as training opportunities exist in his work classification or until he has completed his training program.

It is not required that all trainees be on board for the entire length of the contract. A Contractor will have fulfilled his responsibilities under this Training Special Provision if he has provided acceptable training to the number of trainees specified. The number trained shall be determined on the basis of the total number enrolled on the contract for a significant period.

Trainees will be paid at least 60 percent of the appropriate minimum journeyman's rate specified in the contract for the first half of the training period, 75 percent for the third quarter of the training period, and 90 percent for the last quarter of the training period, unless apprentices or trainees in an approved existing program are enrolled as trainees on this project. In that case, the appropriate rates approved by the Departments of Labor or Transportation in connection with the existing program shall apply to all trainees being trained for the same classification who are covered by this Training Special Provision.

The Contractor shall furnish the trainee a copy of the program he will follow in providing the training. The Contractor shall provide each trainee with a certification showing the type and length of training satisfactorily complete.

The Contractor shall provide for the maintenance of records and furnish periodic reports documenting its performance under this Training Special Provision.

For contracts with an awarded contract value of \$500,000 or more, the Contractor is required to comply with the Illinois Works Apprenticeship Initiative (30 ILCS 559/20-20 to 20-25) and all applicable administrative rules to the extent permitted by Section 20-20(g). For federally funded projects, the number of trainees to be trained under this contract, as stated in the Training Special Provisions, will be the established goal for the Illinois Works Apprenticeship Initiative 30 ILCS 559/20-20(g). The Contractor shall make a good faith effort to meet this goal. For federally funded projects, the Illinois Works Apprenticeship Initiative will be implemented using the FHWA approved OJT procedures. The Contractor must comply with the recordkeeping and reporting obligations of the Illinois Works Apprenticeship Initiative for the life of the project, including the certification as to whether the trainee/apprentice labor hour goals were met.

Method of Measurement. The unit of measurement is in hours.

Basis of Payment. This work will be paid for at the contract unit price of 80 cents per hour for TRAINEES. The estimated total number of hours, unit price, and total price have been included in the schedule of prices.

## **IDOT TRAINING PROGRAM GRADUATE ON-THE-JOB TRAINING SPECIAL PROVISION**

Effective: August 1, 2012

Revised: February 2, 2017

In addition to the Contractor's equal employment opportunity (EEO) affirmative action efforts undertaken as required by this Contract, the Contractor is encouraged to participate in the incentive program described below to provide additional on-the-job training to certified graduates of the IDOT pre-apprenticeship training program, as outlined in this Special Provision.

IDOT funds, and various Illinois community colleges operate, pre-apprenticeship training programs throughout the State to provide training and skill-improvement opportunities to promote the increased employment of minority groups, disadvantaged persons and women in all aspects of the highway construction industry. The intent of this IDOT Pre-Apprenticeship Training Program Graduate (TPG) special provision (Special Provision) is to place these certified program graduates on the project site for this Contract in order to provide the graduates with meaningful on-the-job training. Pursuant to this Special Provision, the Contractor must make every reasonable effort to recruit and employ certified TPG trainees to the extent such individuals are available within a practicable distance of the project site.

Specifically, participation of the Contractor or its subcontractor in the Program entitles the participant to reimbursement for graduates' hourly wages at \$15.00 per hour per utilized TPG trainee, subject to the terms of this Special Provision. Reimbursement payment will be made even though the Contractor or subcontractor may also receive additional training program funds from other non-IDOT sources for other non-TPG trainees on the Contract, provided such other source does not specifically prohibit the Contractor or subcontractor from receiving reimbursement from another entity through another program, such as IDOT through the TPG program. With regard to any IDOT funded construction training program other than TPG, however, additional reimbursement for other IDOT programs will not be made beyond the TPG Program described in this Special Provision when the TPG Program is utilized.

No payment will be made to the Contractor if the Contractor or subcontractor fails to provide the required on-site training to TPG trainees, as solely determined by IDOT. A TPG trainee must begin training on the project as soon as the start of work that utilizes the relevant trade skill and the TPG trainee must remain on the project site through completion of the Contract, so long as training opportunities continue to exist in the relevant work classification. Should a TPG trainee's employment end in advance of the completion of the Contract, the Contractor must promptly notify the IDOT District EEO Officer for the Contract that the TPG's involvement in the Contract has ended. The Contractor must supply a written report for the reason the TPG trainee involvement terminated, the hours completed by the TPG trainee on the Contract, and the number of hours for which the incentive payment provided under this Special Provision will be, or has been claimed for the separated TPG trainee.

Finally, the Contractor must maintain all records it creates as a result of participation in the Program on the Contract, and furnish periodic written reports to the IDOT District EEO Officer that document its contractual performance under and compliance with this Special Provision. Finally, through participation in the Program and reimbursement of wages, the Contractor is not relieved of, and IDOT has not waived, the requirements of any federal or state labor or employment law applicable to TPG workers, including compliance with the Illinois Prevailing Wage Act.

**Method of Measurement:** The unit of measurement is in hours.

**Basis of Payment:** This work will be paid for at the contract unit price of \$15.00 per hour for each utilized certified TPG Program trainee (TRAINEES TRAINING PROGRAM GRADUATE). The estimated total number of hours, unit price, and total price must be included in the schedule of prices for the Contract submitted by Contractor prior to beginning work. The initial number of TPG trainees for which the incentive is available for this contract is 3.

The Department has contracted with several educational institutions to provide screening, tutoring and pre-training to individuals interested in working as a TPG trainee in various areas of common construction trade work. Only individuals who have successfully completed a Pre-Apprenticeship Training Program at these IDOT approved institutions are eligible to be TPG trainees. To obtain a list of institutions that can connect the Contractor with eligible TPG trainees, the Contractor may contact: HCCTP TPG Program Coordinator, Office of Business and Workforce Diversity (IDOT OBWD), Room 319, Illinois Department of Transportation, 2300 S. Dirksen Parkway, Springfield, Illinois 62764. Prior to commencing construction with the utilization of a TPG trainee, the Contractor must submit documentation to the IDOT District EEO Officer for the Contract that provides the names and contact information of the TPG trainee(s) to be trained in each selected work classification, proof that the TPG trainee(s) has successfully completed a Pre-Apprenticeship Training Program, proof that the TPG is in an Apprenticeship Training Program approved by the U.S. Department of Labor Bureau of Apprenticeship Training, and the start date for training in each of the applicable work classifications.

To receive payment, the Contractor must provide training opportunities aimed at developing a full journeyworker in the type of trade or job classification involved. During the course of performance of the Contract, the Contractor may seek approval from the IDOT District EEO Officer to employ additional eligible TPG trainees. In the event the Contractor subcontracts a portion of the contracted work, it must determine how many, if any, of the TPGs will be trained by the subcontractor. Though a subcontractor may conduct training, the Contractor retains the responsibility for meeting all requirements imposed by this Special Provision. The Contractor must also include this Special Provision in any subcontract where payment for contracted work performed by a TPG trainee will be passed on to a subcontractor.

Training through the Program is intended to move TPGs toward journeyman status, which is the primary objective of this Special Provision. Accordingly, the Contractor must make every effort to enroll TPG trainees by recruitment through the Program participant educational institutions to the extent eligible TPGs are available within a reasonable geographic area of the project. The Contractor is responsible for demonstrating, through documentation, the recruitment efforts it has undertaken prior to the determination by IDOT whether the Contractor is in compliance with this Special Provision, and therefore, entitled to the Training Program Graduate reimbursement of \$15.00 per hour.

Notwithstanding the on-the-job training requirement of this TPG Special Provision, some minimal off-site training is permissible as long as the offsite training is an integral part of the work of the contract, and does not compromise or conflict with the required on-site training that is central to the purpose of the Program. No individual may be employed as a TPG trainee in any work classification in which he/she has previously successfully completed a training program leading to journeyman status in any trade, or in which he/she has worked at a journeyman level or higher.

**VEHICLE AND EQUIPMENT WARNING LIGHTS (BDE)**

Effective: November 1, 2021

Revised: November 1, 2022

Add the following paragraph after the first paragraph of Article 701.08 of the Standard Specifications:

“The Contractor shall equip all vehicles and equipment with high-intensity oscillating, rotating, or flashing, amber or amber-and-white, warning lights which are visible from all directions. In accordance with 625 ILCS 5/12-215, the lights may only be in operation while the vehicle or equipment is engaged in construction operations.”

**WEEKLY DBE TRUCKING REPORTS (BDE)**

Effective: June 2, 2012

Revised: November 1, 2021

The Contractor shall submit a weekly report of Disadvantaged Business Enterprise (DBE) trucks hired by the Contractor or subcontractors (i.e. not owned by the Contractor or subcontractors) that are used for DBE goal credit.

The report shall be submitted to the Engineer on Department form “SBE 723” within ten business days following the reporting period. The reporting period shall be Sunday through Saturday for each week reportable trucking activities occur.

Any costs associated with providing weekly DBE trucking reports shall be considered as included in the contract unit prices bid for the various items of work involved and no additional compensation will be allowed.

**WOOD SIGN SUPPORT (BDE)**

Effective: November 1, 2023

Add the following to Article 730.02 of the Standard Specifications:

“(c) Preservative Treatment .....1007.12”

Revise the first paragraph of Article 730.03 of the Standard Specifications to read:

“**730.03 General.** Wood sign supports shall be treated. When the 4 x 6 in. (100 x 150 mm) posts are used, they shall be modified to satisfy the breakaway requirements by drilling 1 1/2 in. (38 mm) diameter holes centered at 4 and 18 in. (100 and 450 mm) above the groundline and perpendicular to the centerline of the roadway.”

**WORK ZONE TRAFFIC CONTROL DEVICES (BDE)**

Effective: March 2, 2020

Add the following to Article 701.03 of the Standard Specifications:

“(q) Temporary Sign Supports ..... 1106.02”

Revise the third paragraph of Article 701.14 of the Standard Specifications to read:

“For temporary sign supports, the Contractor shall provide a FHWA eligibility letter for each device used on the contract. The letter shall provide information for the set-up and use of the device as well as a detailed drawing of the device. The signs shall be supported within 20 degrees of vertical. Weights used to stabilize signs shall be attached to the sign support per the manufacturer’s specifications.”

Revise the first paragraph of Article 701.15 of the Standard Specifications to read:

**“701.15 Traffic Control Devices.** For devices that must meet crashworthiness standards, the Contractor shall provide a manufacturer’s self-certification or a FHWA eligibility letter for each Category 1 device and a FHWA eligibility letter for each Category 2 and Category 3 device used on the contract. The self-certification or letter shall provide information for the set-up and use of the device as well as a detailed drawing of the device.”

Revise the first six paragraphs of Article 1106.02 of the Standard Specifications to read:

**“1106.02 Devices.** Work zone traffic control devices and combinations of devices shall meet crashworthiness standards for their respective categories. The categories are as follows.

Category 1 includes small, lightweight, channelizing and delineating devices that have been in common use for many years and are known to be crashworthy by crash testing of similar devices or years of demonstrable safe performance. These include cones, tubular markers, plastic drums, and delineators, with no attachments (e.g. lights). Category 1 devices manufactured after December 31, 2019 shall be MASH-16 compliant. Category 1 devices manufactured on or before December 31, 2019, and compliant with NCHRP 350 or MASH 2009, may be used on contracts let before December 31, 2024.

Category 2 includes devices that are not expected to produce significant vehicular velocity change but may otherwise be hazardous. These include vertical panels with lights, barricades, temporary sign supports, and Category 1 devices with attachments (e.g. drums with lights). Category 2 devices manufactured after December 31, 2019 shall be MASH-16 compliant. Category 2 devices manufactured on or before December 31, 2019, and compliant with NCHRP 350 or MASH 2009, may be used on contracts let before December 31, 2024.

Category 3 includes devices that are expected to cause significant velocity changes or other potentially harmful reactions to impacting vehicles. These include crash cushions (impact attenuators), truck mounted attenuators, and other devices not meeting the definitions of Category 1 or 2. Category 3 devices manufactured after December 31, 2019 shall be MASH-16 compliant. Category 3 devices manufactured on or before December 31, 2019, and compliant with NCHRP 350 or MASH 2009, may be used on contracts let before December 31, 2029. Category 3 devices shall be crash tested for Test Level 3 or the test level specified.

Category 4 includes portable or trailer-mounted devices such as arrow boards, changeable message signs, temporary traffic signals, and area lighting supports. It is preferable for Category 4 devices manufactured after December 31, 2019 to be MASH-16 compliant; however, there are currently no crash tested devices in this category, so it remains exempt from the NCHRP 350 or MASH compliance requirement.

For each type of device, when no more than one MASH-16 compliant is available, an NCHRP 350 or MASH-2009 compliant device may be used, even if manufactured after December 31, 2019.”

Revise Articles 1106.02(g), 1106.02(k), and 1106.02(l) to read:

“(g) Truck Mounted/Trailer Mounted Attenuators. The attenuator shall be approved for use at Test Level 3. Test Level 2 may be used for normal posted speeds less than or equal to 45 mph.

(k) Temporary Water Filled Barrier. The water filled barrier shall be a lightweight plastic shell designed to accept water ballast and be on the Department’s qualified product list.

Shop drawings shall be furnished by the manufacturer and shall indicate the deflection of the barrier as determined by acceptance testing; the configuration of the barrier in that test; and the vehicle weight, velocity, and angle of impact of the deflection test. The Engineer shall be provided one copy of the shop drawings.

(l) Movable Traffic Barrier. The movable traffic barrier shall be on the Department’s qualified product list.

Shop drawings shall be furnished by the manufacturer and shall indicate the deflection of the barrier as determined by acceptance testing; the configuration of the barrier in that test; and the vehicle weight, velocity, and angle of impact of the deflection test. The Engineer shall be provided one copy of the shop drawings. The barrier shall be capable of being moved on and off the roadway on a daily basis.”

## **MENTOR-PROTÉGÉ PROGRAM**

Effective: June 1, 2007      Revised: February 1, 2013

**Eligibility.** This contract is eligible for the Department's Mentor-Protégé Program for those bidders with an approved Mentor-Protégé Development Plan.

In order for a Mentor-Protégé relationship to be recognized as part of this contract, the Protégé shall be used as a subcontractor and a Mentor-Protégé Agreement for Contract Assistance and Training shall be fully executed and approved. The Mentor-Protégé Agreement for Contract Assistance and Training shall be completed on the form provided by the Department and submitted with the DBE Utilization Plan for approval by the Department. If approved, the Mentor-Protégé Agreement for Contract Assistance and Training shall become part of the contract. In the event the Mentor-Protégé Agreement for Contract Assistance and Training is not approved, the contract shall be performed in accordance with the DBE Utilization Plan exclusive of the Agreement.

**DBE Goal Reduction.** The DBE participation goal set for this contract may, at the discretion of the Department, be reduced according to the Mentor-Protégé Program Guidelines when the Protégé is used as a subcontractor. When submitting the DBE Utilization Plan, the bidder shall indicate whether the Protégé will be used as a subcontractor and to what extent.

**Quarterly Reports.** The Mentor shall submit quarterly progress reports as outlined in the Mentor-Protégé Program Implementation document. The reports shall indicate the progress toward each of the Plan's stated goals. The reports shall be signed by an authorized principal of each firm and submitted to the Engineer of Construction.

Failure to timely submit reports, or submission of incomplete reports may result in dissolution of relationship.

**Reimbursement of Mentor Expenses.** The direct and indirect expenses of the Mentor, as detailed in the approved Mentor-Protégé Agreement for Contract Assistance and Training will be reimbursed by the Department.



## **PROJECT LABOR AGREEMENT**

Effective: May 18, 2007

Revised: August 1, 2019

**Description.** The Illinois Project Labor Agreements Act, 30 ILCS 571, states that the State of Illinois has a compelling interest in awarding public works contracts so as to ensure the highest standards of quality and efficiency at the lowest responsible cost. A project labor agreement (PLA) is a form of pre-hire collective bargaining agreement covering all terms and conditions of employment on a specific project that is intended to support this compelling interest. It has been determined by the Department that a PLA is appropriate for the project that is the subject of this contract. The PLA document, provided below, only applies to the construction site for this contract. It is the policy of the Department on this contract, and all construction projects, to allow all contractors and subcontractors to compete for contracts and subcontracts without regard to whether they are otherwise parties to collective bargaining agreements.

**Execution of Letter of Assent.** A copy of the PLA applicable to this project is included as part of this special provision. As a condition of the award of the contract, the successful bidder and each of its subcontractors shall execute a "Contractor Letter of Assent", in the form attached to the PLA as Exhibit A. The successful bidder shall submit a Subcontractor's Contractor Letter of Assent to the Department prior to the subcontractor's performance of work on the project. Upon request, copies of the applicable collective bargaining agreements will be provided by the appropriate signatory labor organization at the pre-job conference.

**Quarterly Reporting.** Section 37 of the Illinois Project Labor Agreements Act requires the Department to submit quarterly reports regarding the number of minorities and females employed under PLAs. To assist in this reporting effort, the Contractor shall provide a quarterly workforce participation report for all minority and female employees working under the PLA of this contract. The data shall be reported on Construction Form BC 820, Project Labor Agreement (PLA) Workforce Participation Quarterly Reporting Form available on the Department's website <http://www.idot.illinois.gov/Assets/uploads/files/IDOT-Forms/BC/BC%20820.docx>.

The report shall be submitted no later than the 15th of the month following the end of each quarter (i.e., April 15 for the January – March reporting period). The form shall be emailed to [DOT.PLA.Reporting@illinois.gov](mailto:DOT.PLA.Reporting@illinois.gov) or faxed to (217) 524-4922.

Any costs associated with complying with this provision shall be considered as included in the contract unit prices bid for the various items of work involved and no additional compensation will be allowed.

Illinois Department of Transportation

**PROJECT LABOR AGREEMENT**

This Project Labor Agreement (“PLA” or “Agreement”) is entered into this \_\_\_\_\_ day of \_\_\_\_\_, 2024, by and between the Illinois Department of Transportation (“IDOT” or “Department”) in its proprietary capacity, and each relevant Illinois AFL-CIO Building Trades signatory hereto as determined by the Illinois AFL-CIO Statewide Project Labor Agreement Committee on behalf of each of its affiliated members (individually and collectively, the “Unions”). This PLA shall apply to Construction Work (as defined herein) to be performed by IDOT’s Prime Contractor and each of its subcontractors of whatever tier (“Subcontractor” or “Subcontractors”) on Contract No. 62R26(hereinafter, the “Project”).

**ARTICLE 1 - INTENT AND PURPOSES**

- 1.1 This PLA is entered into in accordance with the Project Labor Agreement Act (“Act”, 30 ILCS 571). It is mutually understood and agreed that the terms and conditions of this PLA are intended to promote the public interest in obtaining timely and economical completion of the Project by encouraging productive and efficient construction operations; by establishing a spirit of harmony and cooperation among the parties; and by providing for peaceful and prompt settlement of any and all labor grievances or jurisdictional disputes of any kind without strikes, lockouts, slowdowns, delays, or other disruptions to the prosecution of the work. The parties acknowledge the obligations of the Contractors and Subcontractors to comply with the provisions of the Act. The parties will work with the Contractors and Subcontractors within the parameters of other statutory and regulatory requirements to implement the Act’s goals and objectives.
  
- 1.2 As a condition of the award of the contract for performance of work on the Project, IDOT’s Prime Contractor and each of its Subcontractors shall execute a “Contractor Letter of Assent”, in the form attached hereto as Exhibit A, prior to commencing Construction Work on the Project. The Contractor shall submit a Subcontractor’s Contractor Letter of Assent to the Department prior to the Subcontractor’s performance of Construction Work on the Project. Upon request copies of the applicable collective bargaining agreements will be provided by the appropriate signatory labor organization consistent with this Agreement and at the pre-job conference referenced in Article III, Section 3.1.

- 1.3 Each Union affiliate and separate local representing workers engaged in Construction Work on the Project in accordance with this PLA are bound to this agreement by the Illinois AFL-CIO Statewide Project Labor Agreement Committee which is the central committee established with full authority to negotiate and sign PLAs with the State on behalf of all respective crafts. Upon their signing the Contractor Letter of Assent, the Prime Contractor, each Subcontractor, and the individual Unions shall thereafter be deemed a party to this PLA. No party signatory to this PLA shall, contract or subcontract, nor permit any other person, firm, company, or entity to contract or subcontract for the performance of Construction Work for the Project to any person, firm, company, or entity that does not agree in writing to become bound for the term of this Project by the terms of this PLA prior to commencing such work and to the applicable area-wide collective bargaining agreement(s) with the Union(s) signatory hereto.
- 1.4 It is understood that the Prime Contractor(s) and each Subcontractor will be considered and accepted by the Unions as separate employers for the purposes of collective bargaining, and it is further agreed that the employees working under this PLA shall constitute a bargaining unit separate and distinct from all others. The parties hereto also agree that this PLA shall be applicable solely with respect to this Project, and shall have no bearing on the interpretation of any other collective bargaining agreement or as to the recognition of any bargaining unit other than for the specific purposes of this Project.
- 1.5 In the event of a variance or conflict, whether explicit or implicit, between the terms and conditions of this PLA and the provisions of any other applicable national, area, or local collective bargaining agreement, the terms and conditions of this PLA shall supersede and control. For any work performed under the NTL Articles of Agreement, the National Stack/Chimney Agreement, the National Cooling Tower Agreement, the National Agreement of the International Union of Elevator Constructors, and for any instrument calibration work and loop checking performed under the UA/IBEW Joint National Agreement for Instrument and Control Systems Technicians, the preceding sentence shall apply only with respect to Articles I, II, V, VI, and VII.

- 1.6 Subject to the provisions of paragraph 1.5 of this Article, it is the parties' intent to respect the provisions of any other collective bargaining agreements that may now or hereafter pertain, whether between the Prime Contractor and one or more of the Unions or between a Subcontractor and one or more of the Unions. Accordingly, except and to the extent of any contrary provision set forth in this PLA, the Prime Contractor and each of its Subcontractors agrees to be bound and abide by the terms of the following in order of precedence: (a) the applicable collective bargaining agreement between the Prime Contractor and one or more of the Unions made signatory hereto; (b) the applicable collective bargaining agreement between a Subcontractor and one or more of the Unions made signatory hereto; or (c) the current applicable area collective bargaining agreement for the relevant Union that is the agreement certified by the Illinois Department of Labor for purposes of establishing the Prevailing Wage applicable to the Project. The Union will provide copies of the applicable collective bargaining agreements pursuant to part (c) of the preceding sentence to the Prime Contractor. Assignments by the Contractors or Subcontractors amongst the trades shall be consistent with area practices; in the event of unresolved disagreements as to the propriety of such assignments, the provisions of Article VI shall apply.
- 1.7 Subject to the limitations of paragraphs 1.4 to 1.6 of this Article, the terms of each applicable collective bargaining agreement as determined in accordance with paragraph 1.6 are incorporated herein by reference, and the terms of this PLA shall be deemed incorporated into such other applicable collective bargaining agreements only for purposes of their application to the Project.
- 1.8 To the extent necessary to comply with the requirements of any fringe benefit fund to which the Prime Contractor or Subcontractor is required to contribute under the terms of an applicable collective bargaining agreement pursuant to the preceding paragraph, the Prime Contractor or Subcontractor shall execute all "Participation Agreements" as may be reasonably required by the Union to accomplish such purpose; provided, however, that such Participation Agreements shall, when applicable to the Prime Contractor or Subcontractor solely as a result of this PLA, be amended as reasonably necessary to reflect such fact. Upon written notice in the form of a lien of a Contractor's or Subcontractor's delinquency from any applicable fringe benefit fund, IDOT will withhold from the Contractor's periodic pay request an amount sufficient to extinguish any delinquency obligation of the Contractor or Subcontractor arising out of the Project.
- 1.9 In the event that the applicable collective bargaining agreement between a Prime Contractor and the Union or between the Subcontractor and the Union expires prior to the completion of this Project, the expired applicable contract's terms will be maintained until a new applicable collective bargaining agreement is ratified. The wages and fringe benefits included in any new applicable collective bargaining agreement will apply on and after the effective date of the newly negotiated collective bargaining agreement, except to the extent wage and fringe benefit retroactivity is specifically agreed upon by the relevant bargaining parties.

**ARTICLE II – APPLICABILITY, RECOGNITION, AND COMMITMENTS**

- 2.1 The term Construction Work as used herein shall include all “construction, demolition, rehabilitation, renovation, or repair” work performed by a “laborer or mechanic” at the “site of the work” for the purpose of “building” the specific structures and improvements that constitute the Project. Terms appearing within quotation marks in the preceding sentence shall have the meaning ascribed to them pursuant to 29 CFR Part 5 and Illinois labor laws.
- 2.2 By executing the Letters of Assent, Prime Contractor and each of its Subcontractors recognizes the Unions signatory to this PLA as the sole and exclusive bargaining representatives for their craft employees employed on the jobsite for this Project. Unions who are signatory to this PLA will have recognition on the Project for their craft.
- 2.3 The Prime Contractor and each of its Subcontractors retains and shall be permitted to exercise full and exclusive authority and responsibility for the management of its operations, except as expressly limited by the terms of this PLA or by the terms and conditions of the applicable collective bargaining agreement.
- 2.4 Except to the extent contrary to an express provision of the relevant collective bargaining agreement, equipment or materials used in the Project may be pre-assembled or pre-fabricated, and there shall be no refusal by the Union to handle, transport, install, or connect such equipment or materials. Equipment or materials delivered to the job-site will be unloaded and handled promptly without regard to potential jurisdictional disputes; any such disputes shall be handled in accordance with the provisions of this PLA.
- 2.5 The parties are mutually committed to promoting a safe working environment for all personnel at the job-site. It shall be the responsibility of each employer to which this PLA applies to provide and maintain safe working conditions for its employees, and to comply with all applicable federal, state, and local health and safety laws and regulations.
- 2.6 The use or furnishing of alcohol or drugs and the conduct of any other illegal activity at the job-site is strictly prohibited. The parties shall take every practical measure consistent with the terms of applicable collective bargaining agreements to ensure that the job-site is free of alcohol and drugs.
- 2.7 All parties to this PLA agree that they will not discriminate against any employee based on race, creed, religion, color, national origin, union activity, age, gender or sexual orientation and shall comply with all applicable federal, state, and local laws.

- 2.8 In accordance with the Act and to promote diversity in employment, IDOT will establish, in cooperation with the other parties, the apprenticeship hours which are to be performed by minorities and females on the Project. IDOT shall consider the total hours to be performed by these underrepresented groups, as a percentage of the workforce, and create aspirational goals for each Project, based on the level of underutilization for the service area of the Project (together "Project Employment Objectives"). IDOT shall provide a quarterly report regarding the racial and gender composition of the workforce on the Project.

Persons currently lacking qualifications to enter apprenticeship programs will have the opportunity to obtain skills through basic training programs as have been established by the Department. The parties will endeavor to support such training programs to allow participants to obtain the requisite qualifications for the Project Employment Objectives.

The parties agree that all Contractors and Subcontractors working on the Project shall be encouraged to utilize the maximum number of apprentices as permitted under the terms of the applicable collective bargaining agreements to realize the Project Employment Objectives.

The Unions shall assist the Contractor and each Subcontractor in efforts to satisfy Project Employment Objectives. A Contractor or Subcontractor may request from a Union specific categories of workers necessary to satisfy Project Employment Objectives. The application of this section shall be consistent with all local Union collective bargaining agreements, and the hiring hall rules and regulations established for the hiring of personnel, as well as the apprenticeship standards set forth by each individual Union.

- 2.9 The parties hereto agree that engineering consultants and materials testing employees, to the extent subject to the terms of this PLA, shall be fully expected to objectively and responsibly perform their duties and obligations owed to the Department without regard to the potential union affiliation of such employees or of other employees on the Project.
- 2.10 This Agreement shall not apply to IDOT employees or employees of any other governmental entity.

### **ARTICLE III - ADMINISTRATION OF AGREEMENT**

- 3.1 In order to assure that all parties have a clear understanding of the PLA, and to promote harmony, at the request of the Unions a post-award pre-job conference will be held among the Prime Contractor, all Subcontractors and Union representatives prior to the start of any Construction Work on the Project. No later than the conclusion of such pre-job conference, the parties shall, among other matters, provide to one another contact information for their respective representatives (including name, address, phone number, facsimile number, e-mail). Nothing herein shall be construed to limit the right of the Department to discuss or explain the purpose and intent of this PLA with prospective bidders or other interested parties prior to or following its award of the job.
- 3.2 Representatives of the Prime Contractor and the Unions shall meet as often as reasonably necessary following award until completion of the Project to assure the effective implementation of this PLA.
- 3.3 Any notice contemplated under Article VI and VII of this Agreement to a signatory labor organization shall be made in writing to the Local Union with copies to the local union's International Representative.

### **ARTICLE IV - HOURS OF WORK AND GENERAL CONDITIONS**

- 4.1 The standard work day and work week for Construction Work on the Project shall be consistent with the respective collective bargaining agreements. In the event Project site or other job conditions dictate a change in the established starting time and/or a staggered lunch period for portions of the Project or for specific crafts, the Prime Contractor, relevant Subcontractors and business managers of the specific crafts involved shall confer and mutually agree to such changes as appropriate. If proposed work schedule changes cannot be mutually agreed upon between the parties, the hours fixed at the time of the pre-job meeting shall prevail.
- 4.2 Shift work may be established and directed by the Prime Contractor or relevant Subcontractor as reasonably necessary or appropriate to fulfill the terms of its contract with the Department. If used, shift hours, rates and conditions shall be as provided in the applicable collective bargaining agreement.
- 4.3 The parties agree that chronic and/or unexcused absenteeism is undesirable and must be controlled in accordance with procedures established by the applicable collective bargaining agreement. Any employee disciplined for absenteeism in accordance with such procedures shall be suspended from all work on the Project for not less than the maximum period permitted under the applicable collective bargaining agreement.

- 4.4 Except as may be otherwise expressly provided by the applicable collective bargaining agreement, employment begins and ends at the Project site; employees shall be at their place of work at the starting time; and employees shall remain at their place of work until quitting time.
- 4.5 Except as may be otherwise expressly provided by the applicable collective bargaining agreement, there shall be no limit on production by workmen, no restrictions on the full use of tools or equipment, and no restrictions on efficient use of manpower or techniques of construction other than as may be required by safety regulations.
- 4.6 The parties recognize that specialized or unusual equipment may be installed on the Project. In such cases, the Union recognizes the right of the Prime Contractor or Subcontractor to involve the equipment supplier or vendor's personnel in supervising the setting up of the equipment, making modifications and final alignment, and performing similar activities that may be reasonably necessary prior to and during the start-up procedure in order to protect factory warranties. The Prime Contractor or Subcontractor shall notify the Union representatives in advance of any work at the job-site by such vendor personnel in order to promote a harmonious relationship between the equipment vendor's personnel and other Project employees.
- 4.7 For the purpose of promoting full and effective implementation of this PLA, authorized Union representatives shall have access to the Project job-site during scheduled work hours. Such access shall be conditioned upon adherence to all reasonable visitor and security rules of general applicability that may be established for the Project site at the pre-job conference or from time to time thereafter.

**ARTICLE V – GRIEVANCE PROCEDURES FOR DISPUTES ARISING UNDER A PARTICULAR COLLECTIVE BARGAINING AGREEMENT**

- 5.1 In the event a dispute arises under a particular collective bargaining agreement specifically not including jurisdictional disputes referenced in Article VI below, said dispute shall be resolved by the Grievance/Arbitration procedure of the applicable collective bargaining agreement. The resulting determination from this process shall be final and binding on all parties bound to its process.
- 5.2 Employers covered under this Agreement shall have the right to discharge or discipline any employee who violates the provisions of this Agreement. Such discharge or discipline by a contractor or subcontractor shall be subject to Grievance/Arbitration procedure of the applicable collective bargaining agreement only as to the fact of such violation of this agreement. If such fact is established, the penalty imposed shall not be disturbed. Work at the Project site shall continue without disruption or hindrance of any kind as a result of a Grievance/Arbitration procedure under this Article.



- 5.3 In the event there is a deadlock in the foregoing procedure, the parties agree that the matter shall be submitted to arbitration for the selection and decision of an Arbitrator governed under paragraph 6.8.

#### **ARTICLE VI –DISPUTES: GENERAL PRINCIPLES**

- 6.1 This Agreement is entered into to prevent strikes, lost time, lockouts and to facilitate the peaceful adjustment of jurisdictional disputes in the building and construction industry and to prevent waste and unnecessary avoidable delays and expense, and for the further purpose of at all times securing for the employer sufficient skilled workers.
- 6.2 A panel of Permanent Arbitrators are attached as addendum (A) to this agreement. By mutual agreement between IDOT and the Unions, the parties can open this section of the agreement as needed to make changes to the list of permanent arbitrators.

The arbitrator is not authorized to award back pay or any other damages for a miss assignment of work. Nor may any party bring an independent action for back pay or any other damages, based upon a decision of an arbitrator.

- 6.3 The PLA Jurisdictional Dispute Resolution Process (“Process”) sets forth the procedures below to resolve jurisdictional disputes between and among Contractors, Subcontractors, and Unions engaged in the building and construction industry. Further, the Process will be followed for any grievance or dispute arising out of the interpretation or application of this PLA by the parties except for the prohibition on attorneys contained in 6.11. All decisions made through the Process are final and binding upon all parties.

#### **DISPUTE PROCESS**

- 6.4 Administrative functions under the Process shall be performed through the offices of the President and/or Secretary-Treasurer of the Illinois State Federation of Labor, or their designated representative, called the Administrator. In no event shall any officer, employee, agent, attorney, or other representative of the Illinois Federation of Labor, AFL- CIO be subject to any subpoena to appear or testify at any jurisdictional dispute hearing.
- 6.5 There shall be no abandonment of work during any case participating in this Process or in violation of the arbitration decision. All parties to this Process release the Illinois State Federation of Labor (“Federation”) from any liability arising from its action or inaction and covenant not to sue the Federation, nor its officers, employees, agents or attorneys.

- 6.6 In the event of a dispute relating to trade or work jurisdiction, all parties, including the employers, Contractors or Subcontractors, agree that a final and binding resolution of the dispute shall be resolved as follows:
- (a) Representatives of the affected trades and the Contractor or Subcontractor shall meet on the job site within two (2) business days after receiving written notice in an effort to resolve the dispute. (In the event there is a dispute between local unions affiliated with the same International Union, the decision of the General President, or his/her designee, as the internal jurisdictional authority of that International Union, shall constitute a final and binding decision and determination as to the jurisdiction of work.)
  - (b) If no settlement is achieved subsequent to the preceding Paragraph, the matter shall be referred to the local area Building & Construction Trades Council, which shall meet with the affected trades within two (2) business days subsequent to receiving written notice. In the event the parties do not wish to avail themselves of the local Building & Construction Trades Council, the parties may elect to invoke the services of their respective International Representatives with no extension of the time limitations. An agreement reached at this Step shall be final and binding upon all parties.
  - (c) If no settlement agreement is reached during the proceedings contemplated by Paragraphs "a" or "b" above, the matter shall be immediately referred to the Illinois Jurisdictional Dispute Process for final and binding resolution of said dispute. Said referral submission shall be in writing and served upon the Illinois State Federation of Labor, or the Administrator, pursuant to paragraph 6.4 of this agreement. The Administrator shall, within three (3) days, provide for the selection of an available Arbitrator to hear said dispute within this time period. Upon good cause shown and determined by the Administrator, an additional three (3) day extension for said hearing shall be granted at the sole discretion of the Administrator. Only upon mutual agreement of all parties may the Administrator extend the hearing for a period in excess of the time frames contemplated under this Paragraph. Business days are defined as Monday through Friday, excluding contract holidays.
- 6.7 The primary concern of the Process shall be the adjustment of jurisdictional disputes arising out of the Project. A sufficient number of Arbitrators shall be selected from list of approved Arbitrators as referenced Sec. 6.2 and shall be assigned per Sec. 6.8. Decisions shall be only for the Project and shall become effective immediately upon issuance and complied with by all parties. The authority of the Arbitrator shall be restricted and limited specifically to the terms and provisions of Article VI and generally to this Agreement as a whole.

- 6.8 Arbitrator chosen shall be randomly selected based on the list of Arbitrators in Sec. 6.2 and geographical location of the jurisdictional dispute and upon his/her availability, and ability to conduct a Hearing within two (2) business days of said notice. The Arbitrator may issue a "bench" decision immediately following the Hearing or he/she may elect to only issue a written decision, said decision must be issued within two (2) business days subsequent to the completion of the Hearing. Copies of all notices, pleadings, supporting memoranda, decisions, etc. shall be provided to all disputing parties and the Illinois State Federation of Labor.

Any written decision shall be in accordance with this Process and shall be final and binding upon all parties to the dispute and may be a "short form" decision. Fees and costs of the arbitrator shall be divided evenly between the contesting parties except that any party wishing a full opinion and decision beyond the short form decision shall bear the reasonable fees and costs of such full opinion. The decision of the Arbitrator shall be final and binding upon the parties hereto, their members, and affiliates.

In cases of jurisdictional disputes or other disputes between a signatory labor organization and another labor organization, both of which is an affiliate or member of the same International Union, the matter or dispute shall be settled in the manner set forth by their International Constitution and/or as determined by the International Union's General President whose decision shall be final and binding upon all parties. In no event shall there be an abandonment of work.

- 6.9 In rendering a decision, the Arbitrator shall determine:
- (a) First, whether a previous agreement of record or applicable agreement, including a disclaimer agreement, between National or International Unions to the dispute or agreements between local unions involved in the dispute, governs;
  - (b) Only if the Arbitrator finds that the dispute is not covered by an appropriate or applicable agreement of record or agreement between the crafts to the dispute, he shall then consider the established trade practice in the industry and prevailing practice in the locality. Where there is a previous decision of record governing the case, the Arbitrator shall give equal weight to such decision of record, unless the prevailing practice in the locality in the past ten years favors one craft. In that case, the Arbitrator shall base his decision on the prevailing practice in the locality. Except, that if the Arbitrator finds that a craft has improperly obtained the prevailing practice in the locality through raiding, the undercutting of wages or by the use of vertical agreements, the Arbitrator shall rely on the decision of record and established trade practice in the industry rather than the prevailing practice in the locality; and,

- (c) Only if none of the above criteria is found to exist, the Arbitrator shall then consider that because efficiency, cost or continuity and good management are essential to the well being of the industry, the interests of the consumer or the past practices of the employer shall not be ignored.
- (d) The arbitrator is not authorized to award back pay or any other damages for a mis-assignment of work. Nor may any party bring an independent action for back pay or any other damages, based upon a decision of an arbitrator.
- 6.10 The Arbitrator shall set forth the basis for his/her decision and shall explain his/her findings regarding the applicability of the above criteria. If lower ranked criteria are relied upon, the Arbitrator shall explain why the higher-ranked criteria were not deemed applicable. The Arbitrator's decision shall only apply to the Project. Agreements of Record, for other PLA projects, are applicable only to those parties signatory to such agreements. Decisions of Record are those that were either attested to by the former Impartial Jurisdictional Disputes Board or adopted by the National Arbitration Panel.
- 6.11 All interested parties, as determined by the Arbitrator, shall be entitled to make presentations to the Arbitrator. Any interested labor organization affiliated to the PLA Committee and party present at the Hearing, whether making a presentation or not, by such presence shall be deemed to accept the jurisdiction of the Arbitrator and to agree to be bound by its decision. In addition to the representative of the local labor organization, a representative of the labor organization's International Union may appear on behalf of the parties. Each party is responsible for arranging for its witnesses. In the event an Arbitrator's subpoena is required, the party requiring said subpoena shall prepare the subpoena for the Arbitrator to execute. Service of the subpoena upon any witness shall be the responsibility of the issuing party.

Attorneys shall not be permitted to attend or participate in any portion of a Hearing.

The parties are encouraged to determine, prior to Hearing, documentary evidence which may be presented to the Arbitrator on a joint basis.

- 6.12 The Order of Presentation in all Hearings before an Arbitrator shall be
- I. Identification and Stipulation of the Parties
  - II. Unions(s) claiming the disputed work presents its case
  - III. Union(s) assigned the disputed work presents its case
  - IV. Employer assigning the disputed work presents its case
  - V. Evidence from other interested parties (i.e., general contractor, project manager, owner)
  - VI. Rebuttal by union(s) claiming the disputed work
  - VII. Additional submissions permitted and requested by Arbitrator
  - VIII. Closing arguments by the parties

FAI Route 80 (I-80)  
Project NHHP-HISX(002)  
Section FAI 80 21 STRUCTURE 5  
Will County  
Contract No. 62R26

- 6.13 All parties bound to the provisions of this Process hereby release the Illinois State Federation of Labor and IDOT, their respective officers, agents, employees or designated representatives, specifically including any Arbitrator participating in said Process, from any and all liability or claim, of whatsoever nature, and specifically incorporating the protections provided in the Illinois Arbitration Act, as amended from time to time.
- 6.14 The Process, as an arbitration panel, nor its Administrator, shall have any authority to undertake any action to enforce its decision(s). Rather, it shall be the responsibility of the prevailing party to seek appropriate enforcement of a decision, including findings, orders or awards of the Arbitrator or Administrator determining non-compliance with a prior award or decision.
- 6.15 If at any time there is a question as to the jurisdiction of the Illinois Jurisdictional Dispute Resolution Process, the primary responsibility for any determination of the arbitrability of a dispute and the jurisdiction of the Arbitrator shall be borne by the party requesting the Arbitrator to hear the underlying jurisdictional dispute. The affected party or parties may proceed before the Arbitrator even in the absence or one or more stipulated parties with the issue of jurisdiction as an additional item to be decided by the Arbitrator. The Administrator may participate in proceedings seeking a declaration or determination that the underlying dispute is subject to the jurisdiction and process of the Illinois Jurisdictional Dispute Resolution Process. In any such proceedings, the non-prevailing party and/or the party challenging the jurisdiction of the Illinois Jurisdictional Dispute Resolution Process shall bear all the costs, expenses and attorneys' fees incurred by the Illinois Jurisdictional Dispute Resolution Process and/or its Administrator in establishing its jurisdiction.

#### **ARTICLE VII - WORK STOPPAGES AND LOCKOUTS**

- 7.1 During the term of this PLA, no Union or any of its members, officers, stewards, employees, agents or representatives shall instigate, support, sanction, maintain, or participate in any strike, picketing, walkout, work stoppage, slow down or other activity that interferes with the routine and timely prosecution of work at the Project site or at any other contractor's or supplier's facility that is necessary to performance of work at the Project site. Hand billing at the Project site during the designated lunch period and before commencement or following conclusion of the established standard workday shall not, in itself, be deemed an activity that interferes with the routine and timely prosecution of work on the Project.

7.2 Should any activity prohibited by paragraph 7.1 of this Article occur, the Union shall undertake all steps reasonably necessary to promptly end such prohibited activities.

7.2.A No Union complying with its obligations under this Article shall be liable for acts of employees for which it has no responsibility or for the unauthorized acts of employees it represents. Any employee who participates or encourages any activity prohibited by paragraph 7.1 shall be immediately suspended from all work on the Project for a period equal to the greater of (a) 60 days; or (b) the maximum disciplinary period allowed under the applicable collective bargaining agreement for engaging in comparable unauthorized or prohibited activity.

7.2.B Neither the PLA Committee nor its affiliates shall be liable for acts of employees for which it has no responsibility. The principal officer or officers of the PLA Committee will immediately instruct, order and use the best efforts of his office to cause the affiliated union or unions to cease any violations of this Article. The PLA Committee in its compliance with this obligation shall not be liable for acts of its affiliates. The principal officer or officers of any involved affiliate will immediately instruct, order or use the best effort of his office to cause the employees the union represents to cease any violations of this Article. A union complying with this obligation shall not be liable for unauthorized acts of employees it represents. The failure of the Contractor to exercise its rights in any instance shall not be deemed a waiver of its rights in any other instance.

During the term of this PLA, the Prime Contractor and its Subcontractors shall not engage in any lockout at the Project site of employees covered by this Agreement.

7.3 Upon notification of violations of this Article, the principal officer or officers of the local area Building and Construction Trades Council, and the Illinois AFL-CIO Statewide Project Labor Agreement Committee as appropriate, will immediately instruct, order and use their best efforts to cause the affiliated union or unions to cease any violations of this Article. A Trades Council and the Committee otherwise in compliance with the obligations under this paragraph shall not be liable for unauthorized acts of its affiliates.

7.4 In the event that activities in violation of this Article are not immediately halted through the efforts of the parties, any aggrieved party may invoke the special arbitration provisions set forth in paragraph 7.5 of this Article.

- 7.5 Upon written notice to the other involved parties by the most expeditious means available, any aggrieved party may institute the following special arbitration procedure when a breach of this Article is alleged:
- 7.5.A The party invoking this procedure shall notify the individual designated as the Permanent Arbitrator pursuant to paragraph 6.8 of the nature of the alleged violation; such notice shall be by the most expeditious means possible. The initiating party may also furnish such additional factual information as may be reasonably necessary for the Permanent Arbitrator to understand the relevant circumstances. Copies of any written materials provided to the arbitrator shall also be contemporaneously provided by the most expeditious means possible to the party alleged to be in violation and to all other involved parties.
- 7.5.B Upon receipt of said notice the Permanent Arbitrator shall set and hold a hearing within twenty-four (24) hours if it is contended the violation is ongoing, but not before twenty-four (24) hours after the written notice to all parties involved as required above.
- 7.5.C The Permanent Arbitrator shall notify the parties by facsimile or any other effective written means, of the place and time chosen by the Permanent Arbitrator for this hearing. Said hearing shall be completed in one session. A failure of any party or parties to attend said hearing shall not delay the hearing of evidence or issuance of an Award by the Permanent Arbitrator.
- 7.5.D The sole issue at the hearing shall be whether a violation of this Article has, in fact, occurred. An Award shall be issued in writing within three (3) hours after the close of the hearing, and may be issued without a written opinion. If any party desires a written opinion, one shall be issued within fifteen (15) days, but its issuance shall not delay compliance with, or enforcement of, the Award. The Permanent Arbitrator may order cessation of the violation of this Article, and such Award shall be served on all parties by hand or registered mail upon issuance.
- 7.5.E Such Award may be enforced by any court of competent jurisdiction upon the filing of the Award and such other relevant documents as may be required. Facsimile or other hardcopy written notice of the filing of such enforcement proceedings shall be given to the other relevant parties. In a proceeding to obtain a temporary order enforcing the Permanent Arbitrator's Award as issued under this Article, all parties waive the right to a hearing and agree that such proceedings may be ex parte. Such agreement does not waive any party's right to participate in a hearing for a final order of enforcement. The Court's order or orders enforcing the Permanent Arbitrator's Award shall be served on all parties by hand or by delivery to their last known address or by registered mail.



- 7.6 Individuals found to have violated the provisions of this Article are subject to immediate termination. In addition, IDOT reserves the right to terminate this PLA as to any party found to have violated the provisions of this Article.
- 7.7 Any rights created by statute or law governing arbitration proceedings inconsistent with the above procedure or which interfere with compliance therewith are hereby waived by parties to whom they accrue.
- 7.8 The fees and expenses of the Permanent Arbitrator shall be borne by the party or parties found in violation, or in the event no violation is found, such fees and expenses shall be borne by the moving party.

#### **ARTICLE VIII – TERMS OF AGREEMENT**

- 8.1 If any Article or provision of this Agreement shall be declared invalid, inoperative or unenforceable by operation of law or by any of the above mentioned tribunals of competent jurisdiction, the remainder of this Agreement or the application of such Article or provision to persons or circumstances other than those as to which it has been held invalid, inoperative or unenforceable shall not be affected thereby.
- 8.2 This Agreement shall be in full force as of and from the date of the Notice of Award until the Project contract is closed.
- 8.3 This PLA may not be changed or modified except by the subsequent written agreement of the parties. All parties represent that they have the full legal authority to enter into this PLA. This PLA may be executed by the parties in one or more counterparts.
- 8.4 Any liability arising out of this PLA shall be several and not joint. IDOT shall not be liable to any person or other party for any violation of this PLA by any other party, and no Contractor or Union shall be liable for any violation of this PLA by any other Contractor or Union.
- 8.5 The failure or refusal of a party to exercise its rights hereunder in one or more instances shall not be deemed a waiver of any such rights in respect of a separate instance of the same or similar nature.

[The Balance of This Page Intentionally Left Blank]

Addendum A

IDOT Slate of Permanent Arbitrators

1. Bruce Feldacker
2. Thomas F. Gibbons
3. Edward J. Harrick
4. Brent L. Motchan
5. Robert Perkovich
6. Byron Yaffee
7. Glenn A. Zipp

Exhibit A - Contractor Letter of Assent

(Date)

To All Parties:

In accordance with the terms and conditions of the contract for Construction Work on [Contract No. 62R26], this Letter of Assent hereby confirms that the undersigned Prime Contractor or Subcontractor agrees to be bound by the terms and conditions of the Project Labor Agreement established and entered into by the Illinois Department of Transportation in connection with said Project.

It is the understanding and intent of the undersigned party that this Project Labor Agreement shall pertain only to the identified Project. In the event it is necessary for the undersigned party to become signatory to a collective bargaining agreement to which it is not otherwise a party in order that it may lawfully make certain required contributions to applicable fringe benefit funds, the undersigned party hereby expressly conditions its acceptance of and limits its participation in such collective bargaining agreement to its work on the Project.

(Authorized Company Officer)

(Company)

## **WORKFORCE SUPPORTIVE SERVICES**

To strengthen existing workforce diversity initiatives, the Department has partnered with the Chicago Women in Trades to create a workforce supportive services program that connects stakeholders to achieve a stronger workforce equity outcome. This program applies to the Contractor and each subcontractor as defined below. The Contractor shall include the following in each subcontract the Contractor signs with a subcontractor.

ACHIEVING WORKFORCE HIRING GOALS. In order to increase the Contractor's good faith efforts to meet or exceed the workforce goals outlined in Check Sheet #3 "EEO" of the Recurring Special Provisions, the Contractor shall cooperate with the Workforce Supportive Services Committee (WSSC) assigned to this contract. Cooperation will include meeting regularly with the WSSC to discuss ongoing workforce utilization efforts. It may also include implementing recommendations when hiring goals are not being met. The WSSC is also available to assist with retention barriers and should be utilized to review concerns being experienced by workers on site.

PARTICIPATION IN THE WORKFORCE SUPPORTIVE SERVICES COMMITTEE. The Contractor shall meet with the WSSC at least once a month to discuss recruitment and placement to achieve workforce diversity goals. Subcontractors who need assistance in efforts for increasing diversity on the jobsite may also be required to attend. The Contractor shall work closely with the WSSC to obtain guidance and implement strategies for retaining and supporting diverse workers on the site, including connecting workers with available supportive services.

The Contractor shall display a WSSC provided poster in a visible location where workers on site may access it.

The Contractor shall cooperate with the WSSC should they make periodic site visits or provide feedback on a company's code of conduct.

CODE OF CONDUCT. The Contractor is expected to uphold a code of conduct reflecting zero tolerance for harassment. The Contractor shall submit copies of its established code of conduct and code of conduct for each subcontractor to the Engineer and the WSSC prior to the start of work.

RISE-UP WORKSITE CONDUCT TRAINING. The Contractor shall participate in Rise-Up training for their executive, management, and worker staff unless evidence of a previous attendance is submitted. The trainings shall be scheduled through the WSSC and conducted according to the following.

- (a) Executive Training. Each executive that has an active role in or jurisdiction over the project shall attend Rise-Up's "Executive Team Training and Coaching" within 30 days of the Contractor or any subcontractor beginning work.

(b) Management Training. Within 30 days of the Contractor or any subcontractor beginning work on the jobsite, each foreman, superintendent, project engineer, or any supervisor on site shall attend Rise-Up’s “Field Supervisor Skills Training” and a select group of these individuals shall also attend Rise-Up’s “Site Implementation Training” and “Job Box Talk Train-the-Trainer”.

The select group of supervisors and/or managers shall conduct the Welcome Introduction and 5-15 minute Job Box Talks to workers and each subcontractor on site on a regular basis. They shall also help Rise-Up conduct “Worker Orientation” training.

(c) Worker Training. Each worker performing prevailing wage covered work for 40 hours or more shall attend Rise-Up’s “Worker Orientation” training within 30 days of their start of work on the jobsite, as well as the supervisor/manager conducted Welcome Introduction and 5-15 minute Job Box Talks.

Each subcontractor on site shall attend the Welcome Introduction and 5-15 minute Job Box Talks. Subcontractors on site performing prevailing wage covered work for at least one month shall also attend Rise-Up’s “Field Supervisor Skills Training” and “Worker Orientation” as they become available. A select group of subcontractor supervisors and/or managers shall also attend Rise-Up’s “Job Box Talk Train-the-Trainer”.

**BASIS OF PAYMENT.** Rise-Up training will be paid for by others and organized through the WSSC. Costs associated with employee participation in the training shall be included in the cost of the contract. The expected length of each training, for the purpose of including manhours in the bid, will be according to the following.

<b>Executive Team Training and Coaching</b> (For information only)	
Training Purpose	The Rise-Up Executive Leadership Training will allow executive leaders the ability to set a leadership example for the rest of their organization to foster an inclusive workplace. Leaders will learn how diversity, equity, and inclusion affect productivity and bottom line, learn the framework of the Rise-Up Program, recognize implicit bias and subtle acts of exclusion, and discuss pathways to an inclusive workplace.
Learning Outcome	<ul style="list-style-type: none"> <li>• Identify the impacts of implementing a diversity equity and inclusion program.</li> <li>• Identify and practice ways to interrupt/challenge implicit bias.</li> <li>• Establish five goals for the organization.</li> <li>• Establish metrics for organizational goals.</li> </ul>
Target Audience	Contractor Executives
Training Deliverer	Certified Trainer (by others)
Training Length	~3 h
Training Cadence	Initial training
Training Type	In-Person Instructor-Led Training preferred

<b>Site Implementation Training</b> (For information only)	
Training Purpose	The Rise-Up Site Implementation training will allow leadership and/or managers to understand the process of implementing Rise-Up on a jobsite, what those steps are, and why it's important. Rise-Up staff will meet with jobsite leaders prior to implementing the program to ensure an understanding and set expectations of a respectable worksite. In turn, participants will help to reduce their job's/jobsites' turnover rates, enhance productivity, and meet financial obligations.
Learning Outcome	<ul style="list-style-type: none"> <li>• What is Rise-Up</li> <li>• The process of implementing Rise-Up education on a jobsite as well as any roadblocks one might face in the process</li> </ul>
Target Audience	Select Group of Supervisors and/or Managers on a Jobsite (~10 individuals)
Training Deliverer	Certified Trainer (by others)
Training Length	~2 h 30 m
Training Cadence	Initial training
Training Type	In-Person Instructor-Led Training preferred

<b>Field Supervisor Skills Training</b> (For information only)	
Training Purpose	The Rise-Up Field Supervisor Skills Training will allow supervisors and/or managers to discuss the items that impact the cultural norms of the site. Managers have a huge influence on their teams and on the cultures of their teams. They are dealing with day-to-day issues, like the conflicts that arise from diverse teams, and they need to set the tone and resolve problems. People leave managers more often than companies. This training will give your managers the tools they need to work in diverse team environments, and understand, identify and stop behaviors that jeopardize worker safety and retention. Training topics include identifying, addressing and resolving inappropriate behavior, prevention and response, and intention vs. impact. Training includes real life scenarios and other activities designed to challenge and grow supervisory skills. Managers will also learn how to facilitate the Welcome Introduction for incoming employees.
Learning Outcome	<ul style="list-style-type: none"> <li>• Gain awareness of implicit bias and stereotypes.</li> <li>• Gain knowledge on what is expected in a respectful workplace and be able to identify and define harassment, hazing and bullying, gender and racial discrimination, and retaliation.</li> <li>• Receive tools for conflict resolution, bystander intervention, and giving and receiving feedback.</li> <li>• Learn how to facilitate Welcome Introduction to new employees.</li> </ul>
Target Audience	Supervisors and/or Managers on a Job Site: project managers, foremen, superintendents, of the contractor, sub-contractors, or owners.
Training Deliverer	Certified Trainer (by others)
Training Length	~3 h
Training Cadence	~Monthly (or as management turns over on the jobsite)
Training Type	In-Person Instruction-Led Training preferred

<b>Welcome Introduction</b> (For information only)	
Training Purpose	Supervisors will welcome in-coming workers to the jobsite. The orientation will enable supervisors to set the stage for the project, including discussing the jobsite's code of conduct and the reporting procedures and consequences for not following it. Managers will also be responsible for signing up new workers for the regularly scheduled employee training.
Learning Outcome	<ul style="list-style-type: none"> <li>• Understanding the jobsite's code of conduct, including expectations and consequences.</li> <li>• Being made aware of reporting procedures for workplace harassment.</li> <li>• Knowing expectations for attending further training offerings.</li> </ul>
Target Audience	Workers new to the jobsite, preferably within the first 3 days
Training Deliverer	Supervisors and/or Managers on a Jobsite: project managers, foremen, superintendents, of the contractor, sub-contractors, or owners (any position that will be instructing the Welcome Introduction course on the jobsite or within the Organization)
Training Length	~ 30 m
Training Cadence	Anytime new employees join the jobsite
Training Type	In-Person Instructor-Led Training preferred (could include video component).

<b>Worker Orientation</b> (For information only)	
Training Purpose	The Rise-Up Worker Orientation training provides participants with the knowledge, skills, and tools to be active participants in creating a respectful workplace. It includes information in accordance with your organization's policies and procedures, as well as relevant information resulting from collective bargaining agreements. This portion of the orientation will be provided by the supervisor or manager on-site and by a union representative or steward.
Learning Outcome	<ul style="list-style-type: none"> <li>• What a respectful workplace consists of.</li> <li>• Contributing factors that are harmful to a jobsite's psychological safety.</li> <li>• Receive tools for bystander intervention and how to handle harmful behaviors.</li> </ul>
Target Audience	Workers new to the jobsite, preferably within the first month
Training Deliverer	Certified Trainer (by others) and Supervisor and/or Managers on Site, Union Representative
Training Length	~ 2 h
Training Type	In-Person Instructor-Led Training preferred
Training Cadence	~Monthly

<b>Job Box Talk Train-the-Trainer</b> (For information only)	
Training Purpose	The Rise-Up Job Box Talk will allow supervisors and/or managers to discuss items impacting the site's cultural norms. Job Box Talks are created to be 5–15 minute training opportunities on a specific diversity, equity or inclusion subject. The train-the-trainer will teach up to 10 people in an organization how to utilize the job box talks and facilitate these conversations. In addition, the organization will receive the Job Box Talk materials and marketing package. Anyone will be able to effectively implement the talks after the training.
Learning Outcome	<ul style="list-style-type: none"> <li>• Reintroduce topics.</li> <li>• Gain knowledge on what is expected in a respectful workplace and be able to identify and define harassment, hazing and bullying, gender and racial discrimination, and retaliation.</li> <li>• Receive tools for conflict resolution, bystander intervention, and giving and receiving feedback.</li> </ul>
Target Audience	Select Group of Supervisors and/or Managers on a Job Site (~10 individuals)
Training Deliverer	Certified Trainer (by others)
Training Length	~2 h 30 m
Training Cadence	~Monthly (or as management turns over on the jobsite)
Training Type	In-Person Instructor-Led Training preferred

Through coordination with the WSSC, the Department may determine that additional training will be needed. Hours needed for employees to attend additional training, as directed by the Engineer, will be paid for according to Article 109.04.

The Department reserves the right to waive any training for any reason. This special provision shall not override or interfere with Article 105.01 Authority of the Engineer.



**REQUIRED CONTRACT PROVISIONS FEDERAL-AID CONSTRUCTION CONTRACTS**

- I. General
- II. Nondiscrimination
- III. Non-segregated Facilities
- IV. Davis-Bacon and Related Act Provisions
- V. Contract Work Hours and Safety Standards Act Provisions
- VI. Subletting or Assigning the Contract
- VII. Safety: Accident Prevention
- VIII. False Statements Concerning Highway Projects
- IX. Implementation of Clean Air Act and Federal Water Pollution Control Act
- X. Certification Regarding Debarment, Suspension, Ineligibility and Voluntary Exclusion
- XI. Certification Regarding Use of Contract Funds for Lobbying
- XII. Use of United States-Flag Vessels:

**ATTACHMENTS**

A. Employment and Materials Preference for Appalachian Development Highway System or Appalachian Local Access Road Contracts (included in Appalachian contracts only)

**I. GENERAL**

1. Form FHWA-1273 must be physically incorporated in each construction contract funded under title 23, United States Code, as required in 23 CFR 633.102(b) (excluding emergency contracts solely intended for debris removal). The contractor (or subcontractor) must insert this form in each subcontract and further require its inclusion in all lower tier subcontracts (excluding purchase orders, rental agreements and other agreements for supplies or services). 23 CFR 633.102(e).

The applicable requirements of Form FHWA-1273 are incorporated by reference for work done under any purchase order, rental agreement or agreement for other services. The prime contractor shall be responsible for compliance by any subcontractor, lower-tier subcontractor or service provider. 23 CFR 633.102(e).

Form FHWA-1273 must be included in all Federal-aid design-build contracts, in all subcontracts and in lower tier subcontracts (excluding subcontracts for design services, purchase orders, rental agreements and other agreements for supplies or services) in accordance with 23 CFR 633.102. The design-builder shall be responsible for compliance by any subcontractor, lower-tier subcontractor or service provider.

Contracting agencies may reference Form FHWA-1273 in solicitation-for-bids or request-for-proposals documents, however, the Form FHWA-1273 must be physically incorporated (not referenced) in all contracts, subcontracts and lower-tier subcontracts (excluding purchase orders, rental agreements and other agreements for supplies or services related to a construction contract). 23 CFR 633.102(b).

2. Subject to the applicability criteria noted in the following sections, these contract provisions shall apply to all work

performed on the contract by the contractor's own organization and with the assistance of workers under the contractor's immediate superintendence and to all work performed on the contract by piecework, station work, or by subcontract. 23 CFR 633.102(d).

3. A breach of any of the stipulations contained in these Required Contract Provisions may be sufficient grounds for withholding of progress payments, withholding of final payment, termination of the contract, suspension / debarment or any other action determined to be appropriate by the contracting agency and FHWA.

4. Selection of Labor: During the performance of this contract, the contractor shall not use convict labor for any purpose within the limits of a construction project on a Federal-aid highway unless it is labor performed by convicts who are on parole, supervised release, or probation. 23 U.S.C. 114(b). The term Federal-aid highway does not include roadways functionally classified as local roads or rural minor collectors. 23 U.S.C. 101(a).

**II. NONDISCRIMINATION** (23 CFR 230.107(a); 23 CFR Part 230, Subpart A, Appendix A; EO 11246)

The provisions of this section related to 23 CFR Part 230, Subpart A, Appendix A are applicable to all Federal-aid construction contracts and to all related construction subcontracts of \$10,000 or more. The provisions of 23 CFR Part 230 are not applicable to material supply, engineering, or architectural service contracts.

In addition, the contractor and all subcontractors must comply with the following policies: Executive Order 11246, 41 CFR Part 60, 29 CFR Parts 1625-1627, 23 U.S.C. 140, Section 504 of the Rehabilitation Act of 1973, as amended (29 U.S.C. 794), Title VI of the Civil Rights Act of 1964, as amended (42 U.S.C. 2000d et seq.), and related regulations including 49 CFR Parts 21, 26, and 27; and 23 CFR Parts 200, 230, and 633.

The contractor and all subcontractors must comply with: the requirements of the Equal Opportunity Clause in 41 CFR 60-1.4(b) and, for all construction contracts exceeding \$10,000, the Standard Federal Equal Employment Opportunity Construction Contract Specifications in 41 CFR 60-4.3.

Note: The U.S. Department of Labor has exclusive authority to determine compliance with Executive Order 11246 and the policies of the Secretary of Labor including 41 CFR Part 60, and 29 CFR Parts 1625-1627. The contracting agency and the FHWA have the authority and the responsibility to ensure compliance with 23 U.S.C. 140, Section 504 of the Rehabilitation Act of 1973, as amended (29 U.S.C. 794), and Title VI of the Civil Rights Act of 1964, as amended (42 U.S.C. 2000d et seq.), and related regulations including 49 CFR Parts 21, 26, and 27; and 23 CFR Parts 200, 230, and 633.

The following provision is adopted from 23 CFR Part 230, Subpart A, Appendix A, with appropriate revisions to conform to the U.S. Department of Labor (US DOL) and FHWA requirements.

**1. Equal Employment Opportunity:** Equal Employment Opportunity (EEO) requirements not to discriminate and to take affirmative action to assure equal opportunity as set forth under laws, executive orders, rules, regulations (see 28 CFR Part 35, 29 CFR Part 1630, 29 CFR Parts 1625-1627, 41 CFR Part 60 and 49 CFR Part 27) and orders of the Secretary of Labor as modified by the provisions prescribed herein, and imposed pursuant to 23 U.S.C. 140, shall constitute the EEO and specific affirmative action standards for the contractor's project activities under this contract. The provisions of the Americans with Disabilities Act of 1990 (42 U.S.C. 12101 et seq.) set forth under 28 CFR Part 35 and 29 CFR Part 1630 are incorporated by reference in this contract. In the execution of this contract, the contractor agrees to comply with the following minimum specific requirement activities of EEO:

a. The contractor will work with the contracting agency and the Federal Government to ensure that it has made every good faith effort to provide equal opportunity with respect to all of its terms and conditions of employment and in their review of activities under the contract. 23 CFR 230.409 (g)(4) & (5).

b. The contractor will accept as its operating policy the following statement:

"It is the policy of this Company to assure that applicants are employed, and that employees are treated during employment, without regard to their race, religion, sex, sexual orientation, gender identity, color, national origin, age or disability. Such action shall include: employment, upgrading, demotion, or transfer; recruitment or recruitment advertising; layoff or termination; rates of pay or other forms of compensation; and selection for training, including apprenticeship, pre-apprenticeship, and/or on-the-job training."

**2. EEO Officer:** The contractor will designate and make known to the contracting officers an EEO Officer who will have the responsibility for and must be capable of effectively administering and promoting an active EEO program and who must be assigned adequate authority and responsibility to do so.

**3. Dissemination of Policy:** All members of the contractor's staff who are authorized to hire, supervise, promote, and discharge employees, or who recommend such action or are substantially involved in such action, will be made fully cognizant of and will implement the contractor's EEO policy and contractual responsibilities to provide EEO in each grade and classification of employment. To ensure that the above agreement will be met, the following actions will be taken as a minimum:

a. Periodic meetings of supervisory and personnel office employees will be conducted before the start of work and then not less often than once every six months, at which time the contractor's EEO policy and its implementation will be reviewed and explained. The meetings will be conducted by the EEO Officer or other knowledgeable company official.

b. All new supervisory or personnel office employees will be given a thorough indoctrination by the EEO Officer, covering all major aspects of the contractor's EEO obligations within thirty days following their reporting for duty with the contractor.

c. All personnel who are engaged in direct recruitment for the project will be instructed by the EEO Officer in the contractor's procedures for locating and hiring minorities and women.

d. Notices and posters setting forth the contractor's EEO policy will be placed in areas readily accessible to employees, applicants for employment and potential employees.

e. The contractor's EEO policy and the procedures to implement such policy will be brought to the attention of employees by means of meetings, employee handbooks, or other appropriate means.

**4. Recruitment:** When advertising for employees, the contractor will include in all advertisements for employees the notation: "An Equal Opportunity Employer." All such advertisements will be placed in publications having a large circulation among minorities and women in the area from which the project work force would normally be derived.

a. The contractor will, unless precluded by a valid bargaining agreement, conduct systematic and direct recruitment through public and private employee referral sources likely to yield qualified minorities and women. To meet this requirement, the contractor will identify sources of potential minority group employees and establish with such identified sources procedures whereby minority and women applicants may be referred to the contractor for employment consideration.

b. In the event the contractor has a valid bargaining agreement providing for exclusive hiring hall referrals, the contractor is expected to observe the provisions of that agreement to the extent that the system meets the contractor's compliance with EEO contract provisions. Where implementation of such an agreement has the effect of discriminating against minorities or women, or obligates the contractor to do the same, such implementation violates Federal nondiscrimination provisions.

c. The contractor will encourage its present employees to refer minorities and women as applicants for employment. Information and procedures with regard to referring such applicants will be discussed with employees.

**5. Personnel Actions:** Wages, working conditions, and employee benefits shall be established and administered, and personnel actions of every type, including hiring, upgrading, promotion, transfer, demotion, layoff, and termination, shall be taken without regard to race, color, religion, sex, sexual orientation, gender identity, national origin, age or disability. The following procedures shall be followed:

a. The contractor will conduct periodic inspections of project sites to ensure that working conditions and employee facilities do not indicate discriminatory treatment of project site personnel.

b. The contractor will periodically evaluate the spread of wages paid within each classification to determine any evidence of discriminatory wage practices.

c. The contractor will periodically review selected personnel actions in depth to determine whether there is evidence of discrimination. Where evidence is found, the contractor will promptly take corrective action. If the review indicates that the discrimination may extend beyond the actions reviewed, such corrective action shall include all affected persons.

d. The contractor will promptly investigate all complaints of alleged discrimination made to the contractor in connection with its obligations under this contract, will attempt to resolve such complaints, and will take appropriate corrective action

within a reasonable time. If the investigation indicates that the discrimination may affect persons other than the complainant, such corrective action shall include such other persons. Upon completion of each investigation, the contractor will inform every complainant of all of their avenues of appeal.

#### **6. Training and Promotion:**

a. The contractor will assist in locating, qualifying, and increasing the skills of minorities and women who are applicants for employment or current employees. Such efforts should be aimed at developing full journey level status employees in the type of trade or job classification involved.

b. Consistent with the contractor's work force requirements and as permissible under Federal and State regulations, the contractor shall make full use of training programs (i.e., apprenticeship and on-the-job training programs for the geographical area of contract performance). In the event a special provision for training is provided under this contract, this subparagraph will be superseded as indicated in the special provision. The contracting agency may reserve training positions for persons who receive welfare assistance in accordance with 23 U.S.C. 140(a).

c. The contractor will advise employees and applicants for employment of available training programs and entrance requirements for each.

d. The contractor will periodically review the training and promotion potential of employees who are minorities and women and will encourage eligible employees to apply for such training and promotion.

**7. Unions:** If the contractor relies in whole or in part upon unions as a source of employees, the contractor will use good faith efforts to obtain the cooperation of such unions to increase opportunities for minorities and women. 23 CFR 230.409. Actions by the contractor, either directly or through a contractor's association acting as agent, will include the procedures set forth below:

a. The contractor will use good faith efforts to develop, in cooperation with the unions, joint training programs aimed toward qualifying more minorities and women for membership in the unions and increasing the skills of minorities and women so that they may qualify for higher paying employment.

b. The contractor will use good faith efforts to incorporate an EEO clause into each union agreement to the end that such union will be contractually bound to refer applicants without regard to their race, color, religion, sex, sexual orientation, gender identity, national origin, age, or disability.

c. The contractor is to obtain information as to the referral practices and policies of the labor union except that to the extent such information is within the exclusive possession of the labor union and such labor union refuses to furnish such information to the contractor, the contractor shall so certify to the contracting agency and shall set forth what efforts have been made to obtain such information.

d. In the event the union is unable to provide the contractor with a reasonable flow of referrals within the time limit set forth in the collective bargaining agreement, the contractor will, through independent recruitment efforts, fill the employment vacancies without regard to race, color, religion, sex, sexual orientation, gender identity, national origin, age, or disability; making full efforts to obtain qualified and/or qualifiable minorities and women. The failure of a union to provide

sufficient referrals (even though it is obligated to provide exclusive referrals under the terms of a collective bargaining agreement) does not relieve the contractor from the requirements of this paragraph. In the event the union referral practice prevents the contractor from meeting the obligations pursuant to Executive Order 11246, as amended, and these special provisions, such contractor shall immediately notify the contracting agency.

#### **8. Reasonable Accommodation for Applicants /**

**Employees with Disabilities:** The contractor must be familiar with the requirements for and comply with the Americans with Disabilities Act and all rules and regulations established thereunder. Employers must provide reasonable accommodation in all employment activities unless to do so would cause an undue hardship.

#### **9. Selection of Subcontractors, Procurement of Materials and Leasing of Equipment:**

The contractor shall not discriminate on the grounds of race, color, religion, sex, sexual orientation, gender identity, national origin, age, or disability in the selection and retention of subcontractors, including procurement of materials and leases of equipment. The contractor shall take all necessary and reasonable steps to ensure nondiscrimination in the administration of this contract.

a. The contractor shall notify all potential subcontractors, suppliers, and lessors of their EEO obligations under this contract.

b. The contractor will use good faith efforts to ensure subcontractor compliance with their EEO obligations.

#### **10. Assurances Required:**

a. The requirements of 49 CFR Part 26 and the State DOT's FHWA-approved Disadvantaged Business Enterprise (DBE) program are incorporated by reference.

b. The contractor, subrecipient or subcontractor shall not discriminate on the basis of race, color, national origin, or sex in the performance of this contract. The contractor shall carry out applicable requirements of 49 CFR part 26 in the award and administration of DOT-assisted contracts. Failure by the contractor to carry out these requirements is a material breach of this contract, which may result in the termination of this contract or such other remedy as the recipient deems appropriate, which may include, but is not limited to:

- (1) Withholding monthly progress payments;
- (2) Assessing sanctions;
- (3) Liquidated damages; and/or
- (4) Disqualifying the contractor from future bidding as non-responsible.

c. The Title VI and nondiscrimination provisions of U.S. DOT Order 1050.2A at Appendixes A and E are incorporated by reference. 49 CFR Part 21.

**11. Records and Reports:** The contractor shall keep such records as necessary to document compliance with the EEO requirements. Such records shall be retained for a period of three years following the date of the final payment to the contractor for all contract work and shall be available at reasonable times and places for inspection by authorized representatives of the contracting agency and the FHWA.

a. The records kept by the contractor shall document the following:

(1) The number and work hours of minority and non-minority group members and women employed in each work classification on the project;

(2) The progress and efforts being made in cooperation with unions, when applicable, to increase employment opportunities for minorities and women; and

(3) The progress and efforts being made in locating, hiring, training, qualifying, and upgrading minorities and women.

b. The contractors and subcontractors will submit an annual report to the contracting agency each July for the duration of the project indicating the number of minority, women, and non-minority group employees currently engaged in each work classification required by the contract work. This information is to be reported on [Form FHWA-1391](#). The staffing data should represent the project work force on board in all or any part of the last payroll period preceding the end of July. If on-the-job training is being required by special provision, the contractor will be required to collect and report training data. The employment data should reflect the work force on board during all or any part of the last payroll period preceding the end of July.

### III. NONSEGREGATED FACILITIES

This provision is applicable to all Federal-aid construction contracts and to all related construction subcontracts of more than \$10,000. 41 CFR 60-1.5.

As prescribed by 41 CFR 60-1.8, the contractor must ensure that facilities provided for employees are provided in such a manner that segregation on the basis of race, color, religion, sex, sexual orientation, gender identity, or national origin cannot result. The contractor may neither require such segregated use by written or oral policies nor tolerate such use by employee custom. The contractor's obligation extends further to ensure that its employees are not assigned to perform their services at any location under the contractor's control where the facilities are segregated. The term "facilities" includes waiting rooms, work areas, restaurants and other eating areas, time clocks, restrooms, washrooms, locker rooms and other storage or dressing areas, parking lots, drinking fountains, recreation or entertainment areas, transportation, and housing provided for employees. The contractor shall provide separate or single-user restrooms and necessary dressing or sleeping areas to assure privacy between sexes.

### IV. DAVIS-BACON AND RELATED ACT PROVISIONS

This section is applicable to all Federal-aid construction projects exceeding \$2,000 and to all related subcontracts and lower-tier subcontracts (regardless of subcontract size), in accordance with 29 CFR 5.5. The requirements apply to all projects located within the right-of-way of a roadway that is functionally classified as Federal-aid highway. 23 U.S.C. 113. This excludes roadways functionally classified as local roads or rural minor collectors, which are exempt. 23 U.S.C. 101. Where applicable law requires that projects be treated as a project on a Federal-aid highway, the provisions of this subpart will apply regardless of the location of the project. Examples include: Surface Transportation Block Grant Program projects funded under 23 U.S.C. 133 [excluding recreational trails projects], the Nationally Significant Freight and Highway

Projects funded under 23 U.S.C. 117, and National Highway Freight Program projects funded under 23 U.S.C. 167.

The following provisions are from the U.S. Department of Labor regulations in 29 CFR 5.5 "Contract provisions and related matters" with minor revisions to conform to the FHWA- 1273 format and FHWA program requirements.

#### 1. Minimum wages (29 CFR 5.5)

a. *Wage rates and fringe benefits.* All laborers and mechanics employed or working upon the site of the work (or otherwise working in construction or development of the project under a development statute), will be paid unconditionally and not less often than once a week, and without subsequent deduction or rebate on any account (except such payroll deductions as are permitted by regulations issued by the Secretary of Labor under the Copeland Act ([29 CFR part 3](#))), the full amount of basic hourly wages and bona fide fringe benefits (or cash equivalents thereof) due at time of payment computed at rates not less than those contained in the wage determination of the Secretary of Labor which is attached hereto and made a part hereof, regardless of any contractual relationship which may be alleged to exist between the contractor and such laborers and mechanics. As provided in paragraphs (d) and (e) of 29 CFR 5.5, the appropriate wage determinations are effective by operation of law even if they have not been attached to the contract. Contributions made or costs reasonably anticipated for bona fide fringe benefits under the Davis-Bacon Act ([40 U.S.C. 3141\(2\)\(B\)](#)) on behalf of laborers or mechanics are considered wages paid to such laborers or mechanics, subject to the provisions of paragraph 1.e. of this section; also, regular contributions made or costs incurred for more than a weekly period (but not less often than quarterly) under plans, funds, or programs which cover the particular weekly period, are deemed to be constructively made or incurred during such weekly period. Such laborers and mechanics must be paid the appropriate wage rate and fringe benefits on the wage determination for the classification(s) of work actually performed, without regard to skill, except as provided in paragraph 4. of this section. Laborers or mechanics performing work in more than one classification may be compensated at the rate specified for each classification for the time actually worked therein: *Provided*, That the employer's payroll records accurately set forth the time spent in each classification in which work is performed. The wage determination (including any additional classifications and wage rates conformed under paragraph 1.c. of this section) and the Davis-Bacon poster (WH-1321) must be posted at all times by the contractor and its subcontractors at the site of the work in a prominent and accessible place where it can be easily seen by the workers.

b. *Frequently recurring classifications.* (1) In addition to wage and fringe benefit rates that have been determined to be prevailing under the procedures set forth in [29 CFR part 1](#), a wage determination may contain, pursuant to § 1.3(f), wage and fringe benefit rates for classifications of laborers and mechanics for which conformance requests are regularly submitted pursuant to paragraph 1.c. of this section, provided that:

(i) The work performed by the classification is not performed by a classification in the wage determination for which a prevailing wage rate has been determined;

(ii) The classification is used in the area by the construction industry; and

(iii) The wage rate for the classification bears a reasonable relationship to the prevailing wage rates contained in the wage determination.

(2) The Administrator will establish wage rates for such classifications in accordance with paragraph 1.c.(1)(iii) of this section. Work performed in such a classification must be paid at no less than the wage and fringe benefit rate listed on the wage determination for such classification.

**c. Conformance.** (1) The contracting officer must require that any class of laborers or mechanics, including helpers, which is not listed in the wage determination and which is to be employed under the contract be classified in conformance with the wage determination. Conformance of an additional classification and wage rate and fringe benefits is appropriate only when the following criteria have been met:

(i) The work to be performed by the classification requested is not performed by a classification in the wage determination; and

(ii) The classification is used in the area by the construction industry; and

(iii) The proposed wage rate, including any bona fide fringe benefits, bears a reasonable relationship to the wage rates contained in the wage determination.

(2) The conformance process may not be used to split, subdivide, or otherwise avoid application of classifications listed in the wage determination.

(3) If the contractor and the laborers and mechanics to be employed in the classification (if known), or their representatives, and the contracting officer agree on the classification and wage rate (including the amount designated for fringe benefits where appropriate), a report of the action taken will be sent by the contracting officer by email to [DBAconformance@dol.gov](mailto:DBAconformance@dol.gov). The Administrator, or an authorized representative, will approve, modify, or disapprove every additional classification action within 30 days of receipt and so advise the contracting officer or will notify the contracting officer within the 30-day period that additional time is necessary.

(4) In the event the contractor, the laborers or mechanics to be employed in the classification or their representatives, and the contracting officer do not agree on the proposed classification and wage rate (including the amount designated for fringe benefits, where appropriate), the contracting officer will, by email to [DBAconformance@dol.gov](mailto:DBAconformance@dol.gov), refer the questions, including the views of all interested parties and the recommendation of the contracting officer, to the Administrator for determination. The Administrator, or an authorized representative, will issue a determination within 30 days of receipt and so advise the contracting officer or will notify the contracting officer within the 30-day period that additional time is necessary.

(5) The contracting officer must promptly notify the contractor of the action taken by the Wage and Hour Division

under paragraphs 1.c.(3) and (4) of this section. The contractor must furnish a written copy of such determination to each affected worker or it must be posted as a part of the wage determination. The wage rate (including fringe benefits where appropriate) determined pursuant to paragraph 1.c.(3) or (4) of this section must be paid to all workers performing work in the classification under this contract from the first day on which work is performed in the classification.

**d. Fringe benefits not expressed as an hourly rate.**

Whenever the minimum wage rate prescribed in the contract for a class of laborers or mechanics includes a fringe benefit which is not expressed as an hourly rate, the contractor may either pay the benefit as stated in the wage determination or may pay another bona fide fringe benefit or an hourly cash equivalent thereof.

**e. Unfunded plans.** If the contractor does not make payments to a trustee or other third person, the contractor may consider as part of the wages of any laborer or mechanic the amount of any costs reasonably anticipated in providing bona fide fringe benefits under a plan or program, *Provided*, That the Secretary of Labor has found, upon the written request of the contractor, in accordance with the criteria set forth in § 5.28, that the applicable standards of the Davis-Bacon Act have been met. The Secretary of Labor may require the contractor to set aside in a separate account assets for the meeting of obligations under the plan or program.

**f. Interest.** In the event of a failure to pay all or part of the wages required by the contract, the contractor will be required to pay interest on any underpayment of wages.

## **2. Withholding (29 CFR 5.5)**

**a. Withholding requirements.** The contracting agency may, upon its own action, or must, upon written request of an authorized representative of the Department of Labor, withhold or cause to be withheld from the contractor so much of the accrued payments or advances as may be considered necessary to satisfy the liabilities of the prime contractor or any subcontractor for the full amount of wages and monetary relief, including interest, required by the clauses set forth in this section for violations of this contract, or to satisfy any such liabilities required by any other Federal contract, or federally assisted contract subject to Davis-Bacon labor standards, that is held by the same prime contractor (as defined in § 5.2). The necessary funds may be withheld from the contractor under this contract, any other Federal contract with the same prime contractor, or any other federally assisted contract that is subject to Davis-Bacon labor standards requirements and is held by the same prime contractor, regardless of whether the other contract was awarded or assisted by the same agency, and such funds may be used to satisfy the contractor liability for which the funds were withheld. In the event of a contractor's failure to pay any laborer or mechanic, including any apprentice or helper working on the site of the work all or part of the wages required by the contract, or upon the contractor's failure to submit the required records as discussed in paragraph 3.d. of this section, the contracting agency may on its own initiative and after written notice to the contractor, take such action as may be necessary to cause the suspension of any further payment, advance, or guarantee of funds until such violations have ceased.

**b. Priority to withheld funds.** The Department has priority to funds withheld or to be withheld in accordance with paragraph

2.a. of this section or Section V, paragraph 3.a., or both, over claims to those funds by:

- (1) A contractor's surety(ies), including without limitation performance bond sureties and payment bond sureties;
- (2) A contracting agency for its procurement costs;
- (3) A trustee(s) (either a court-appointed trustee or a U.S. trustee, or both) in bankruptcy of a contractor, or a contractor's bankruptcy estate;
- (4) A contractor's assignee(s);
- (5) A contractor's successor(s); or
- (6) A claim asserted under the Prompt Payment Act, [31 U.S.C. 3901–3907](#).

### 3. Records and certified payrolls (29 CFR 5.5)

*a. Basic record requirements (1) Length of record retention.* All regular payrolls and other basic records must be maintained by the contractor and any subcontractor during the course of the work and preserved for all laborers and mechanics working at the site of the work (or otherwise working in construction or development of the project under a development statute) for a period of at least 3 years after all the work on the prime contract is completed.

*(2) Information required.* Such records must contain the name; Social Security number; last known address, telephone number, and email address of each such worker; each worker's correct classification(s) of work actually performed; hourly rates of wages paid (including rates of contributions or costs anticipated for bona fide fringe benefits or cash equivalents thereof of the types described in [40 U.S.C. 3141\(2\)\(B\)](#) of the Davis-Bacon Act); daily and weekly number of hours actually worked in total and on each covered contract; deductions made; and actual wages paid.

*(3) Additional records relating to fringe benefits.* Whenever the Secretary of Labor has found under paragraph 1.e. of this section that the wages of any laborer or mechanic include the amount of any costs reasonably anticipated in providing benefits under a plan or program described in [40 U.S.C. 3141\(2\)\(B\)](#) of the Davis-Bacon Act, the contractor must maintain records which show that the commitment to provide such benefits is enforceable, that the plan or program is financially responsible, and that the plan or program has been communicated in writing to the laborers or mechanics affected, and records which show the costs anticipated or the actual cost incurred in providing such benefits.

*(4) Additional records relating to apprenticeship.* Contractors with apprentices working under approved programs must maintain written evidence of the registration of apprenticeship programs, the registration of the apprentices, and the ratios and wage rates prescribed in the applicable programs.

*b. Certified payroll requirements (1) Frequency and method of submission.* The contractor or subcontractor must submit weekly, for each week in which any DBA- or Related Acts-covered work is performed, certified payrolls to the contracting

agency. The prime contractor is responsible for the submission of all certified payrolls by all subcontractors. A contracting agency or prime contractor may permit or require contractors to submit certified payrolls through an electronic system, as long as the electronic system requires a legally valid electronic signature; the system allows the contractor, the contracting agency, and the Department of Labor to access the certified payrolls upon request for at least 3 years after the work on the prime contract has been completed; and the contracting agency or prime contractor permits other methods of submission in situations where the contractor is unable or limited in its ability to use or access the electronic system.

*(2) Information required.* The certified payrolls submitted must set out accurately and completely all of the information required to be maintained under paragraph 3.a.(2) of this section, except that full Social Security numbers and last known addresses, telephone numbers, and email addresses must not be included on weekly transmittals. Instead, the certified payrolls need only include an individually identifying number for each worker (e.g., the last four digits of the worker's Social Security number). The required weekly certified payroll information may be submitted using Optional Form WH-347 or in any other format desired. Optional Form WH-347 is available for this purpose from the Wage and Hour Division website at <https://www.dol.gov/sites/dolgov/files/WHDLegacy/files/wh347.pdf> or its successor website. It is not a violation of this section for a prime contractor to require a subcontractor to provide full Social Security numbers and last known addresses, telephone numbers, and email addresses to the prime contractor for its own records, without weekly submission by the subcontractor to the contracting agency.

*(3) Statement of Compliance.* Each certified payroll submitted must be accompanied by a "Statement of Compliance," signed by the contractor or subcontractor, or the contractor's or subcontractor's agent who pays or supervises the payment of the persons working on the contract, and must certify the following:

(i) That the certified payroll for the payroll period contains the information required to be provided under paragraph 3.b. of this section, the appropriate information and basic records are being maintained under paragraph 3.a. of this section, and such information and records are correct and complete;

(ii) That each laborer or mechanic (including each helper and apprentice) working on the contract during the payroll period has been paid the full weekly wages earned, without rebate, either directly or indirectly, and that no deductions have been made either directly or indirectly from the full wages earned, other than permissible deductions as set forth in [29 CFR part 3](#); and

(iii) That each laborer or mechanic has been paid not less than the applicable wage rates and fringe benefits or cash equivalents for the classification(s) of work actually performed, as specified in the applicable wage determination incorporated into the contract.

*(4) Use of Optional Form WH-347.* The weekly submission of a properly executed certification set forth on the reverse side of Optional Form WH-347 will satisfy the requirement for submission of the "Statement of Compliance" required by paragraph 3.b.(3) of this section.



(5) *Signature*. The signature by the contractor, subcontractor, or the contractor's or subcontractor's agent must be an original handwritten signature or a legally valid electronic signature.

(6) *Falsification*. The falsification of any of the above certifications may subject the contractor or subcontractor to civil or criminal prosecution under [18 U.S.C. 1001](#) and [31 U.S.C. 3729](#).

(7) *Length of certified payroll retention*. The contractor or subcontractor must preserve all certified payrolls during the course of the work and for a period of 3 years after all the work on the prime contract is completed.

c. *Contracts, subcontracts, and related documents*. The contractor or subcontractor must maintain this contract or subcontract and related documents including, without limitation, bids, proposals, amendments, modifications, and extensions. The contractor or subcontractor must preserve these contracts, subcontracts, and related documents during the course of the work and for a period of 3 years after all the work on the prime contract is completed.

d. *Required disclosures and access* (1) *Required record disclosures and access to workers*. The contractor or subcontractor must make the records required under paragraphs 3.a. through 3.c. of this section, and any other documents that the contracting agency, the State DOT, the FHWA, or the Department of Labor deems necessary to determine compliance with the labor standards provisions of any of the applicable statutes referenced by § 5.1, available for inspection, copying, or transcription by authorized representatives of the contracting agency, the State DOT, the FHWA, or the Department of Labor, and must permit such representatives to interview workers during working hours on the job.

(2) *Sanctions for non-compliance with records and worker access requirements*. If the contractor or subcontractor fails to submit the required records or to make them available, or refuses to permit worker interviews during working hours on the job, the Federal agency may, after written notice to the contractor, sponsor, applicant, owner, or other entity, as the case may be, that maintains such records or that employs such workers, take such action as may be necessary to cause the suspension of any further payment, advance, or guarantee of funds. Furthermore, failure to submit the required records upon request or to make such records available, or to permit worker interviews during working hours on the job, may be grounds for debarment action pursuant to § 5.12. In addition, any contractor or other person that fails to submit the required records or make those records available to WHD within the time WHD requests that the records be produced will be precluded from introducing as evidence in an administrative proceeding under [29 CFR part 6](#) any of the required records that were not provided or made available to WHD. WHD will take into consideration a reasonable request from the contractor or person for an extension of the time for submission of records. WHD will determine the reasonableness of the request and may consider, among other things, the location of the records and the volume of production.

(3) *Required information disclosures*. Contractors and subcontractors must maintain the full Social Security number and last known address, telephone number, and email address

of each covered worker, and must provide them upon request to the contracting agency, the State DOT, the FHWA, the contractor, or the Wage and Hour Division of the Department of Labor for purposes of an investigation or other compliance action.

#### 4. Apprentices and equal employment opportunity (29 CFR 5.5)

a. *Apprentices* (1) *Rate of pay*. Apprentices will be permitted to work at less than the predetermined rate for the work they perform when they are employed pursuant to and individually registered in a bona fide apprenticeship program registered with the U.S. Department of Labor, Employment and Training Administration, Office of Apprenticeship (OA), or with a State Apprenticeship Agency recognized by the OA. A person who is not individually registered in the program, but who has been certified by the OA or a State Apprenticeship Agency (where appropriate) to be eligible for probationary employment as an apprentice, will be permitted to work at less than the predetermined rate for the work they perform in the first 90 days of probationary employment as an apprentice in such a program. In the event the OA or a State Apprenticeship Agency recognized by the OA withdraws approval of an apprenticeship program, the contractor will no longer be permitted to use apprentices at less than the applicable predetermined rate for the work performed until an acceptable program is approved.

(2) *Fringe benefits*. Apprentices must be paid fringe benefits in accordance with the provisions of the apprenticeship program. If the apprenticeship program does not specify fringe benefits, apprentices must be paid the full amount of fringe benefits listed on the wage determination for the applicable classification. If the Administrator determines that a different practice prevails for the applicable apprentice classification, fringe benefits must be paid in accordance with that determination.

(3) *Apprenticeship ratio*. The allowable ratio of apprentices to journeyworkers on the job site in any craft classification must not be greater than the ratio permitted to the contractor as to the entire work force under the registered program or the ratio applicable to the locality of the project pursuant to paragraph 4.a.(4) of this section. Any worker listed on a payroll at an apprentice wage rate, who is not registered or otherwise employed as stated in paragraph 4.a.(1) of this section, must be paid not less than the applicable wage rate on the wage determination for the classification of work actually performed. In addition, any apprentice performing work on the job site in excess of the ratio permitted under this section must be paid not less than the applicable wage rate on the wage determination for the work actually performed.

(4) *Reciprocity of ratios and wage rates*. Where a contractor is performing construction on a project in a locality other than the locality in which its program is registered, the ratios and wage rates (expressed in percentages of the journeyworker's hourly rate) applicable within the locality in which the construction is being performed must be observed. If there is no applicable ratio or wage rate for the locality of the project, the ratio and wage rate specified in the contractor's registered program must be observed.

b. *Equal employment opportunity*. The use of apprentices and journeyworkers under this part must be in conformity with

the equal employment opportunity requirements of Executive Order 11246, as amended, and [29 CFR part 30](#).

c. Apprentices and Trainees (programs of the U.S. DOT).

Apprentices and trainees working under apprenticeship and skill training programs which have been certified by the Secretary of Transportation as promoting EEO in connection with Federal-aid highway construction programs are not subject to the requirements of paragraph 4 of this Section IV. 23 CFR 230.111(e)(2). The straight time hourly wage rates for apprentices and trainees under such programs will be established by the particular programs. The ratio of apprentices and trainees to journeyworkers shall not be greater than permitted by the terms of the particular program.

**5. Compliance with Copeland Act requirements.** The contractor shall comply with the requirements of 29 CFR part 3, which are incorporated by reference in this contract as provided in 29 CFR 5.5.

**6. Subcontracts.** The contractor or subcontractor must insert FHWA-1273 in any subcontracts, along with the applicable wage determination(s) and such other clauses or contract modifications as the contracting agency may by appropriate instructions require, and a clause requiring the subcontractors to include these clauses and wage determination(s) in any lower tier subcontracts. The prime contractor is responsible for the compliance by any subcontractor or lower tier subcontractor with all the contract clauses in this section. In the event of any violations of these clauses, the prime contractor and any subcontractor(s) responsible will be liable for any unpaid wages and monetary relief, including interest from the date of the underpayment or loss, due to any workers of lower-tier subcontractors, and may be subject to debarment, as appropriate. 29 CFR 5.5.

**7. Contract termination: debarment.** A breach of the contract clauses in 29 CFR 5.5 may be grounds for termination of the contract, and for debarment as a contractor and a subcontractor as provided in 29 CFR 5.12.

**8. Compliance with Davis-Bacon and Related Act requirements.** All rulings and interpretations of the Davis-Bacon and Related Acts contained in 29 CFR parts 1, 3, and 5 are herein incorporated by reference in this contract as provided in 29 CFR 5.5.

**9. Disputes concerning labor standards.** As provided in 29 CFR 5.5, disputes arising out of the labor standards provisions of this contract shall not be subject to the general disputes clause of this contract. Such disputes shall be resolved in accordance with the procedures of the Department of Labor set forth in 29 CFR parts 5, 6, and 7. Disputes within the meaning of this clause include disputes between the contractor (or any of its subcontractors) and the contracting agency, the U.S. Department of Labor, or the employees or their representatives.

**10. Certification of eligibility.** a. By entering into this contract, the contractor certifies that neither it nor any person or firm who has an interest in the contractor's firm is a person or firm ineligible to be awarded Government contracts by virtue of [40 U.S.C. 3144\(b\)](#) or § 5.12(a).

b. No part of this contract shall be subcontracted to any person or firm ineligible for award of a Government contract by virtue of [40 U.S.C. 3144\(b\)](#) or § 5.12(a).

c. The penalty for making false statements is prescribed in the U.S. Code, Title 18 Crimes and Criminal Procedure, [18 U.S.C. 1001](#).

**11. Anti-retaliation.** It is unlawful for any person to discharge, demote, intimidate, threaten, restrain, coerce, blacklist, harass, or in any other manner discriminate against, or to cause any person to discharge, demote, intimidate, threaten, restrain, coerce, blacklist, harass, or in any other manner discriminate against, any worker or job applicant for:

a. Notifying any contractor of any conduct which the worker reasonably believes constitutes a violation of the DBA, Related Acts, this part, or [29 CFR part 1](#) or [3](#);

b. Filing any complaint, initiating or causing to be initiated any proceeding, or otherwise asserting or seeking to assert on behalf of themselves or others any right or protection under the DBA, Related Acts, this part, or [29 CFR part 1](#) or [3](#);

c. Cooperating in any investigation or other compliance action, or testifying in any proceeding under the DBA, Related Acts, this part, or [29 CFR part 1](#) or [3](#); or

d. Informing any other person about their rights under the DBA, Related Acts, this part, or [29 CFR part 1](#) or [3](#).

## V. CONTRACT WORK HOURS AND SAFETY STANDARDS ACT

Pursuant to 29 CFR 5.5(b), the following clauses apply to any Federal-aid construction contract in an amount in excess of \$100,000 and subject to the overtime provisions of the Contract Work Hours and Safety Standards Act. These clauses shall be inserted in addition to the clauses required by 29 CFR 5.5(a) or 29 CFR 4.6. As used in this paragraph, the terms laborers and mechanics include watchpersons and guards.

**1. Overtime requirements.** No contractor or subcontractor contracting for any part of the contract work which may require or involve the employment of laborers or mechanics shall require or permit any such laborer or mechanic in any workweek in which he or she is employed on such work to work in excess of forty hours in such workweek unless such laborer or mechanic receives compensation at a rate not less than one and one-half times the basic rate of pay for all hours worked in excess of forty hours in such workweek. 29 CFR 5.5.

**2. Violation; liability for unpaid wages; liquidated damages.** In the event of any violation of the clause set forth in paragraph 1. of this section the contractor and any subcontractor responsible therefor shall be liable for the unpaid wages and interest from the date of the underpayment. In addition, such contractor and subcontractor shall be liable to the United States (in the case of work done under contract for the District of Columbia or a territory, to such District or to such territory), for liquidated damages. Such liquidated damages shall be computed with respect to each individual laborer or



mechanic, including watchpersons and guards, employed in violation of the clause set forth in paragraph 1. of this section, in the sum currently provided in 29 CFR 5.5(b)(2)\* for each calendar day on which such individual was required or permitted to work in excess of the standard workweek of forty hours without payment of the overtime wages required by the clause set forth in paragraph 1. of this section.

\* \$31 as of January 15, 2023 (See 88 FR 88 FR 2210) as may be adjusted annually by the Department of Labor, pursuant to the Federal Civil Penalties Inflation Adjustment Act of 1990.

### 3. Withholding for unpaid wages and liquidated damages

a. *Withholding process.* The FHWA or the contracting agency may, upon its own action, or must, upon written request of an authorized representative of the Department of Labor, withhold or cause to be withheld from the contractor so much of the accrued payments or advances as may be considered necessary to satisfy the liabilities of the prime contractor or any subcontractor for any unpaid wages; monetary relief, including interest; and liquidated damages required by the clauses set forth in this section on this contract, any other Federal contract with the same prime contractor, or any other federally assisted contract subject to the Contract Work Hours and Safety Standards Act that is held by the same prime contractor (as defined in § 5.2). The necessary funds may be withheld from the contractor under this contract, any other Federal contract with the same prime contractor, or any other federally assisted contract that is subject to the Contract Work Hours and Safety Standards Act and is held by the same prime contractor, regardless of whether the other contract was awarded or assisted by the same agency, and such funds may be used to satisfy the contractor liability for which the funds were withheld.

b. *Priority to withheld funds.* The Department has priority to funds withheld or to be withheld in accordance with Section IV paragraph 2.a. or paragraph 3.a. of this section, or both, over claims to those funds by:

- (1) A contractor's surety(ies), including without limitation performance bond sureties and payment bond sureties;
- (2) A contracting agency for its procurement costs;
- (3) A trustee(s) (either a court-appointed trustee or a U.S. trustee, or both) in bankruptcy of a contractor, or a contractor's bankruptcy estate;
- (4) A contractor's assignee(s);
- (5) A contractor's successor(s); or
- (6) A claim asserted under the Prompt Payment Act, [31 U.S.C. 3901](#)–3907.

**4. Subcontracts.** The contractor or subcontractor must insert in any subcontracts the clauses set forth in paragraphs 1. through 5. of this section and a clause requiring the subcontractors to include these clauses in any lower tier subcontracts. The prime contractor is responsible for compliance by any subcontractor or lower tier subcontractor with the clauses set forth in paragraphs 1. through 5. In the

event of any violations of these clauses, the prime contractor and any subcontractor(s) responsible will be liable for any unpaid wages and monetary relief, including interest from the date of the underpayment or loss, due to any workers of lower-tier subcontractors, and associated liquidated damages and may be subject to debarment, as appropriate.

**5. Anti-retaliation.** It is unlawful for any person to discharge, demote, intimidate, threaten, restrain, coerce, blacklist, harass, or in any other manner discriminate against, or to cause any person to discharge, demote, intimidate, threaten, restrain, coerce, blacklist, harass, or in any other manner discriminate against, any worker or job applicant for:

- a. Notifying any contractor of any conduct which the worker reasonably believes constitutes a violation of the Contract Work Hours and Safety Standards Act (CWHSSA) or its implementing regulations in this part;
- b. Filing any complaint, initiating or causing to be initiated any proceeding, or otherwise asserting or seeking to assert on behalf of themselves or others any right or protection under CWHSSA or this part;
- c. Cooperating in any investigation or other compliance action, or testifying in any proceeding under CWHSSA or this part; or
- d. Informing any other person about their rights under CWHSSA or this part.

### VI. SUBLETTING OR ASSIGNING THE CONTRACT

This provision is applicable to all Federal-aid construction contracts on the National Highway System pursuant to 23 CFR 635.116.

1. The contractor shall perform with its own organization contract work amounting to not less than 30 percent (or a greater percentage if specified elsewhere in the contract) of the total original contract price, excluding any specialty items designated by the contracting agency. Specialty items may be performed by subcontract and the amount of any such specialty items performed may be deducted from the total original contract price before computing the amount of work required to be performed by the contractor's own organization (23 CFR 635.116).

a. The term "perform work with its own organization" in paragraph 1 of Section VI refers to workers employed or leased by the prime contractor, and equipment owned or rented by the prime contractor, with or without operators. Such term does not include employees or equipment of a subcontractor or lower tier subcontractor, agents of the prime contractor, or any other assignees. The term may include payments for the costs of hiring leased employees from an employee leasing firm meeting all relevant Federal and State regulatory requirements. Leased employees may only be included in this term if the prime contractor meets all of the following conditions: (based on longstanding interpretation)

- (1) the prime contractor maintains control over the supervision of the day-to-day activities of the leased employees;
- (2) the prime contractor remains responsible for the quality of the work of the leased employees;

- (3) the prime contractor retains all power to accept or exclude individual employees from work on the project; and
- (4) the prime contractor remains ultimately responsible for the payment of predetermined minimum wages, the submission of payrolls, statements of compliance and all other Federal regulatory requirements.

b. "Specialty Items" shall be construed to be limited to work that requires highly specialized knowledge, abilities, or equipment not ordinarily available in the type of contracting organizations qualified and expected to bid or propose on the contract as a whole and in general are to be limited to minor components of the overall contract. 23 CFR 635.102.

2. Pursuant to 23 CFR 635.116(a), the contract amount upon which the requirements set forth in paragraph (1) of Section VI is computed includes the cost of material and manufactured products which are to be purchased or produced by the contractor under the contract provisions.

3. Pursuant to 23 CFR 635.116(c), the contractor shall furnish (a) a competent superintendent or supervisor who is employed by the firm, has full authority to direct performance of the work in accordance with the contract requirements, and is in charge of all construction operations (regardless of who performs the work) and (b) such other of its own organizational resources (supervision, management, and engineering services) as the contracting officer determines is necessary to assure the performance of the contract.

4. No portion of the contract shall be sublet, assigned or otherwise disposed of except with the written consent of the contracting officer, or authorized representative, and such consent when given shall not be construed to relieve the contractor of any responsibility for the fulfillment of the contract. Written consent will be given only after the contracting agency has assured that each subcontract is evidenced in writing and that it contains all pertinent provisions and requirements of the prime contract. (based on long-standing interpretation of 23 CFR 635.116).

5. The 30-percent self-performance requirement of paragraph (1) is not applicable to design-build contracts; however, contracting agencies may establish their own self-performance requirements. 23 CFR 635.116(d).

## VII. SAFETY: ACCIDENT PREVENTION

This provision is applicable to all Federal-aid construction contracts and to all related subcontracts.

1. In the performance of this contract the contractor shall comply with all applicable Federal, State, and local laws governing safety, health, and sanitation (23 CFR Part 635). The contractor shall provide all safeguards, safety devices and protective equipment and take any other needed actions as it determines, or as the contracting officer may determine, to be reasonably necessary to protect the life and health of employees on the job and the safety of the public and to protect property in connection with the performance of the work covered by the contract. 23 CFR 635.108.

2. It is a condition of this contract, and shall be made a condition of each subcontract, which the contractor enters into pursuant to this contract, that the contractor and any subcontractor shall not permit any employee, in performance of the contract, to work in surroundings or under conditions which are unsanitary, hazardous or dangerous to his/her health or safety, as determined under construction safety and

health standards (29 CFR Part 1926) promulgated by the Secretary of Labor, in accordance with Section 107 of the Contract Work Hours and Safety Standards Act (40 U.S.C. 3704). 29 CFR 1926.10.

3. Pursuant to 29 CFR 1926.3, it is a condition of this contract that the Secretary of Labor or authorized representative thereof, shall have right of entry to any site of contract performance to inspect or investigate the matter of compliance with the construction safety and health standards and to carry out the duties of the Secretary under Section 107 of the Contract Work Hours and Safety Standards Act (40 U.S.C. 3704).

## VIII. FALSE STATEMENTS CONCERNING HIGHWAY PROJECTS

This provision is applicable to all Federal-aid construction contracts and to all related subcontracts.

In order to assure high quality and durable construction in conformity with approved plans and specifications and a high degree of reliability on statements and representations made by engineers, contractors, suppliers, and workers on Federal-aid highway projects, it is essential that all persons concerned with the project perform their functions as carefully, thoroughly, and honestly as possible. Willful falsification, distortion, or misrepresentation with respect to any facts related to the project is a violation of Federal law. To prevent any misunderstanding regarding the seriousness of these and similar acts, Form FHWA-1022 shall be posted on each Federal-aid highway project (23 CFR Part 635) in one or more places where it is readily available to all persons concerned with the project:

18 U.S.C. 1020 reads as follows:

"Whoever, being an officer, agent, or employee of the United States, or of any State or Territory, or whoever, whether a person, association, firm, or corporation, knowingly makes any false statement, false representation, or false report as to the character, quality, quantity, or cost of the material used or to be used, or the quantity or quality of the work performed or to be performed, or the cost thereof in connection with the submission of plans, maps, specifications, contracts, or costs of construction on any highway or related project submitted for approval to the Secretary of Transportation; or

Whoever knowingly makes any false statement, false representation, false report or false claim with respect to the character, quality, quantity, or cost of any work performed or to be performed, or materials furnished or to be furnished, in connection with the construction of any highway or related project approved by the Secretary of Transportation; or

Whoever knowingly makes any false statement or false representation as to material fact in any statement, certificate, or report submitted pursuant to provisions of the Federal-aid Roads Act approved July 11, 1916, (39 Stat. 355), as amended and supplemented;

Shall be fined under this title or imprisoned not more than 5 years or both."

**IX. IMPLEMENTATION OF CLEAN AIR ACT AND FEDERAL WATER POLLUTION CONTROL ACT (42 U.S.C. 7606; 2 CFR 200.88; EO 11738)**

This provision is applicable to all Federal-aid construction contracts in excess of \$150,000 and to all related subcontracts. 48 CFR 2.101; 2 CFR 200.327.

By submission of this bid/proposal or the execution of this contract or subcontract, as appropriate, the bidder, proposer, Federal-aid construction contractor, subcontractor, supplier, or vendor agrees to comply with all applicable standards, orders or regulations issued pursuant to the Clean Air Act (42 U.S.C. 7401-7671q) and the Federal Water Pollution Control Act, as amended (33 U.S.C. 1251-1387). Violations must be reported to the Federal Highway Administration and the Regional Office of the Environmental Protection Agency. 2 CFR Part 200, Appendix II.

The contractor agrees to include or cause to be included the requirements of this Section in every subcontract, and further agrees to take such action as the contracting agency may direct as a means of enforcing such requirements. 2 CFR 200.327.

**X. CERTIFICATION REGARDING DEBARMENT, SUSPENSION, INELIGIBILITY AND VOLUNTARY EXCLUSION**

This provision is applicable to all Federal-aid construction contracts, design-build contracts, subcontracts, lower-tier subcontracts, purchase orders, lease agreements, consultant contracts or any other covered transaction requiring FHWA approval or that is estimated to cost \$25,000 or more – as defined in 2 CFR Parts 180 and 1200. 2 CFR 180.220 and 1200.220.

**1. Instructions for Certification – First Tier Participants:**

a. By signing and submitting this proposal, the prospective first tier participant is providing the certification set out below.

b. The inability of a person to provide the certification set out below will not necessarily result in denial of participation in this covered transaction. The prospective first tier participant shall submit an explanation of why it cannot provide the certification set out below. The certification or explanation will be considered in connection with the department or agency's determination whether to enter into this transaction. However, failure of the prospective first tier participant to furnish a certification or an explanation shall disqualify such a person from participation in this transaction. 2 CFR 180.320.

c. The certification in this clause is a material representation of fact upon which reliance was placed when the contracting agency determined to enter into this transaction. If it is later determined that the prospective participant knowingly rendered an erroneous certification, in addition to other remedies available to the Federal Government, the contracting agency may terminate this transaction for cause of default. 2 CFR 180.325.

d. The prospective first tier participant shall provide immediate written notice to the contracting agency to whom this proposal is submitted if any time the prospective first tier participant learns that its certification was erroneous when submitted or has become erroneous by reason of changed circumstances. 2 CFR 180.345 and 180.350.

e. The terms "covered transaction," "debarred," "suspended," "ineligible," "participant," "person," "principal," and "voluntarily excluded," as used in this clause, are defined in 2 CFR Parts 180, Subpart I, 180.900-180.1020, and 1200. "First Tier Covered Transactions" refers to any covered transaction between a recipient or subrecipient of Federal funds and a participant (such as the prime or general contract). "Lower Tier Covered Transactions" refers to any covered transaction under a First Tier Covered Transaction (such as subcontracts). "First Tier Participant" refers to the participant who has entered into a covered transaction with a recipient or subrecipient of Federal funds (such as the prime or general contractor). "Lower Tier Participant" refers any participant who has entered into a covered transaction with a First Tier Participant or other Lower Tier Participants (such as subcontractors and suppliers).

f. The prospective first tier participant agrees by submitting this proposal that, should the proposed covered transaction be entered into, it shall not knowingly enter into any lower tier covered transaction with a person who is debarred, suspended, declared ineligible, or voluntarily excluded from participation in this covered transaction, unless authorized by the department or agency entering into this transaction. 2 CFR 180.330.

g. The prospective first tier participant further agrees by submitting this proposal that it will include the clause titled "Certification Regarding Debarment, Suspension, Ineligibility and Voluntary Exclusion-Lower Tier Covered Transactions," provided by the department or contracting agency, entering into this covered transaction, without modification, in all lower tier covered transactions and in all solicitations for lower tier covered transactions exceeding the \$25,000 threshold. 2 CFR 180.220 and 180.300.

h. A participant in a covered transaction may rely upon a certification of a prospective participant in a lower tier covered transaction that is not debarred, suspended, ineligible, or voluntarily excluded from the covered transaction, unless it knows that the certification is erroneous. 2 CFR 180.300; 180.320, and 180.325. A participant is responsible for ensuring that its principals are not suspended, debarred, or otherwise ineligible to participate in covered transactions. 2 CFR 180.335. To verify the eligibility of its principals, as well as the eligibility of any lower tier prospective participants, each participant may, but is not required to, check the System for Award Management website (<https://www.sam.gov>). 2 CFR 180.300, 180.320, and 180.325.

i. Nothing contained in the foregoing shall be construed to require the establishment of a system of records in order to render in good faith the certification required by this clause. The knowledge and information of the prospective participant is not required to exceed that which is normally possessed by a prudent person in the ordinary course of business dealings.

j. Except for transactions authorized under paragraph (f) of these instructions, if a participant in a covered transaction knowingly enters into a lower tier covered transaction with a person who is suspended, debarred, ineligible, or voluntarily excluded from participation in this transaction, in addition to other remedies available to the Federal Government, the department or agency may terminate this transaction for cause or default. 2 CFR 180.325.

\* \* \* \* \*

**2. Certification Regarding Debarment, Suspension, Ineligibility and Voluntary Exclusion – First Tier Participants:**

a. The prospective first tier participant certifies to the best of its knowledge and belief, that it and its principals:

(1) Are not presently debarred, suspended, proposed for debarment, declared ineligible, or voluntarily excluded from participating in covered transactions by any Federal department or agency, 2 CFR 180.335;

(2) Have not within a three-year period preceding this proposal been convicted of or had a civil judgment rendered against them for commission of fraud or a criminal offense in connection with obtaining, attempting to obtain, or performing a public (Federal, State, or local) transaction or contract under a public transaction; violation of Federal or State antitrust statutes or commission of embezzlement, theft, forgery, bribery, falsification or destruction of records, making false statements, or receiving stolen property, 2 CFR 180.800;

(3) Are not presently indicted for or otherwise criminally or civilly charged by a governmental entity (Federal, State or local) with commission of any of the offenses enumerated in paragraph (a)(2) of this certification, 2 CFR 180.700 and 180.800; and

(4) Have not within a three-year period preceding this application/proposal had one or more public transactions (Federal, State or local) terminated for cause or default. 2 CFR 180.335(d).

(5) Are not a corporation that has been convicted of a felony violation under any Federal law within the two-year period preceding this proposal (USDOT Order 4200.6 implementing appropriations act requirements); and

(6) Are not a corporation with any unpaid Federal tax liability that has been assessed, for which all judicial and administrative remedies have been exhausted, or have lapsed, and that is not being paid in a timely manner pursuant to an agreement with the authority responsible for collecting the tax liability (USDOT Order 4200.6 implementing appropriations act requirements).

b. Where the prospective participant is unable to certify to any of the statements in this certification, such prospective participant should attach an explanation to this proposal. 2 CFR 180.335 and 180.340.

\* \* \* \* \*

**3. Instructions for Certification - Lower Tier Participants:**

(Applicable to all subcontracts, purchase orders, and other lower tier transactions requiring prior FHWA approval or estimated to cost \$25,000 or more - 2 CFR Parts 180 and 1200). 2 CFR 180.220 and 1200.220.

a. By signing and submitting this proposal, the prospective lower tier participant is providing the certification set out below.

b. The certification in this clause is a material representation of fact upon which reliance was placed when this transaction was entered into. If it is later determined that the prospective lower tier participant knowingly rendered an erroneous certification, in addition to other remedies available to the Federal Government, the department, or agency with which

this transaction originated may pursue available remedies, including suspension and/or debarment.

c. The prospective lower tier participant shall provide immediate written notice to the person to which this proposal is submitted if at any time the prospective lower tier participant learns that its certification was erroneous by reason of changed circumstances. 2 CFR 180.365.

d. The terms "covered transaction," "debarred," "suspended," "ineligible," "participant," "person," "principal," and "voluntarily excluded," as used in this clause, are defined in 2 CFR Parts 180, Subpart I, 180.900 – 180.1020, and 1200. You may contact the person to which this proposal is submitted for assistance in obtaining a copy of those regulations. "First Tier Covered Transactions" refers to any covered transaction between a recipient or subrecipient of Federal funds and a participant (such as the prime or general contract). "Lower Tier Covered Transactions" refers to any covered transaction under a First Tier Covered Transaction (such as subcontracts). "First Tier Participant" refers to the participant who has entered into a covered transaction with a recipient or subrecipient of Federal funds (such as the prime or general contractor). "Lower Tier Participant" refers any participant who has entered into a covered transaction with a First Tier Participant or other Lower Tier Participants (such as subcontractors and suppliers).

e. The prospective lower tier participant agrees by submitting this proposal that, should the proposed covered transaction be entered into, it shall not knowingly enter into any lower tier covered transaction with a person who is debarred, suspended, declared ineligible, or voluntarily excluded from participation in this covered transaction, unless authorized by the department or agency with which this transaction originated. 2 CFR 1200.220 and 1200.332.

f. The prospective lower tier participant further agrees by submitting this proposal that it will include this clause titled "Certification Regarding Debarment, Suspension, Ineligibility and Voluntary Exclusion-Lower Tier Covered Transaction," without modification, in all lower tier covered transactions and in all solicitations for lower tier covered transactions exceeding the \$25,000 threshold. 2 CFR 180.220 and 1200.220.

g. A participant in a covered transaction may rely upon a certification of a prospective participant in a lower tier covered transaction that is not debarred, suspended, ineligible, or voluntarily excluded from the covered transaction, unless it knows that the certification is erroneous. A participant is responsible for ensuring that its principals are not suspended, debarred, or otherwise ineligible to participate in covered transactions. To verify the eligibility of its principals, as well as the eligibility of any lower tier prospective participants, each participant may, but is not required to, check the System for Award Management website (<https://www.sam.gov>), which is compiled by the General Services Administration. 2 CFR 180.300, 180.320, 180.330, and 180.335.

h. Nothing contained in the foregoing shall be construed to require establishment of a system of records in order to render in good faith the certification required by this clause. The knowledge and information of participant is not required to exceed that which is normally possessed by a prudent person in the ordinary course of business dealings.

i. Except for transactions authorized under paragraph e of these instructions, if a participant in a covered transaction knowingly enters into a lower tier covered transaction with a person who is suspended, debarred, ineligible, or voluntarily

excluded from participation in this transaction, in addition to other remedies available to the Federal Government, the department or agency with which this transaction originated may pursue available remedies, including suspension and/or debarment. 2 CFR 180.325.

\* \* \* \* \*

**4. Certification Regarding Debarment, Suspension, Ineligibility and Voluntary Exclusion--Lower Tier Participants:**

a. The prospective lower tier participant certifies, by submission of this proposal, that neither it nor its principals:

(1) is presently debarred, suspended, proposed for debarment, declared ineligible, or voluntarily excluded from participating in covered transactions by any Federal department or agency, 2 CFR 180.355;

(2) is a corporation that has been convicted of a felony violation under any Federal law within the two-year period preceding this proposal (USDOT Order 4200.6 implementing appropriations act requirements); and

(3) is a corporation with any unpaid Federal tax liability that has been assessed, for which all judicial and administrative remedies have been exhausted, or have lapsed, and that is not being paid in a timely manner pursuant to an agreement with the authority responsible for collecting the tax liability. (USDOT Order 4200.6 implementing appropriations act requirements)

b. Where the prospective lower tier participant is unable to certify to any of the statements in this certification, such prospective participant should attach an explanation to this proposal.

\* \* \* \* \*

**XI. CERTIFICATION REGARDING USE OF CONTRACT FUNDS FOR LOBBYING**

This provision is applicable to all Federal-aid construction contracts and to all related subcontracts which exceed \$100,000. 49 CFR Part 20, App. A.

1. The prospective participant certifies, by signing and submitting this bid or proposal, to the best of his or her knowledge and belief, that:

a. No Federal appropriated funds have been paid or will be paid, by or on behalf of the undersigned, to any person for influencing or attempting to influence an officer or employee of any Federal agency, a Member of Congress, an officer or employee of Congress, or an employee of a Member of Congress in connection with the awarding of any Federal contract, the making of any Federal grant, the making of any Federal loan, the entering into of any cooperative agreement, and the extension, continuation, renewal, amendment, or modification of any Federal contract, grant, loan, or cooperative agreement.

b. If any funds other than Federal appropriated funds have been paid or will be paid to any person for influencing or attempting to influence an officer or employee of any Federal agency, a Member of Congress, an officer or employee of Congress, or an employee of a Member of Congress in connection with this Federal contract, grant, loan, or

cooperative agreement, the undersigned shall complete and submit Standard Form-LLL, "Disclosure Form to Report Lobbying," in accordance with its instructions.

2. This certification is a material representation of fact upon which reliance was placed when this transaction was made or entered into. Submission of this certification is a prerequisite for making or entering into this transaction imposed by 31 U.S.C. 1352. Any person who fails to file the required certification shall be subject to a civil penalty of not less than \$10,000 and not more than \$100,000 for each such failure.

3. The prospective participant also agrees by submitting its bid or proposal that the participant shall require that the language of this certification be included in all lower tier subcontracts, which exceed \$100,000 and that all such recipients shall certify and disclose accordingly.

**XII. USE OF UNITED STATES-FLAG VESSELS:**

This provision is applicable to all Federal-aid construction contracts, design-build contracts, subcontracts, lower-tier subcontracts, purchase orders, lease agreements, or any other covered transaction. 46 CFR Part 381.

This requirement applies to material or equipment that is acquired for a specific Federal-aid highway project. 46 CFR 381.7. It is not applicable to goods or materials that come into inventories independent of an FHWA funded-contract.

When oceanic shipments (or shipments across the Great Lakes) are necessary for materials or equipment acquired for a specific Federal-aid construction project, the bidder, proposer, contractor, subcontractor, or vendor agrees:

1. To utilize privately owned United States-flag commercial vessels to ship at least 50 percent of the gross tonnage (computed separately for dry bulk carriers, dry cargo liners, and tankers) involved, whenever shipping any equipment, material, or commodities pursuant to this contract, to the extent such vessels are available at fair and reasonable rates for United States-flag commercial vessels. 46 CFR 381.7.

2. To furnish within 20 days following the date of loading for shipments originating within the United States or within 30 working days following the date of loading for shipments originating outside the United States, a legible copy of a rated, 'on-board' commercial ocean bill-of-lading in English for each shipment of cargo described in paragraph (b)(1) of this section to both the Contracting Officer (through the prime contractor in the case of subcontractor bills-of-lading) and to the Office of Cargo and Commercial Sealift (MAR-620), Maritime Administration, Washington, DC 20590. (MARAD requires copies of the ocean carrier's (master) bills of lading, certified onboard, dated, with rates and charges. These bills of lading may contain business sensitive information and therefore may be submitted directly to MARAD by the Ocean Transportation Intermediary on behalf of the contractor). 46 CFR 381.7.

**ATTACHMENT A - EMPLOYMENT AND MATERIALS  
PREFERENCE FOR APPALACHIAN DEVELOPMENT HIGHWAY  
SYSTEM OR APPALACHIAN LOCAL ACCESS**

**ROAD CONTRACTS** (23 CFR 633, Subpart B, Appendix B)

This provision is applicable to all Federal-aid projects funded under the Appalachian Regional Development Act of 1965.

1. During the performance of this contract, the contractor undertaking to do work which is, or reasonably may be, done as on-site work, shall give preference to qualified persons who regularly reside in the labor area as designated by the DOL wherein the contract work is situated, or the subregion, or the Appalachian counties of the State wherein the contract work is situated, except:

a. To the extent that qualified persons regularly residing in the area are not available.

b. For the reasonable needs of the contractor to employ supervisory or specially experienced personnel necessary to assure an efficient execution of the contract work.

c. For the obligation of the contractor to offer employment to present or former employees as the result of a lawful collective bargaining contract, provided that the number of nonresident persons employed under this subparagraph (1c) shall not exceed 20 percent of the total number of employees employed by the contractor on the contract work, except as provided in subparagraph (4) below.

2. The contractor shall place a job order with the State Employment Service indicating (a) the classifications of the laborers, mechanics and other employees required to perform the contract work, (b) the number of employees required in each classification, (c) the date on which the participant estimates such employees will be required, and (d) any other pertinent information required by the State Employment Service to complete the job order form. The job order may be placed with the State Employment Service in writing or by telephone. If during the course of the contract work, the information submitted by the contractor in the original job order is substantially modified, the participant shall promptly notify the State Employment Service.

3. The contractor shall give full consideration to all qualified job applicants referred to him by the State Employment Service. The contractor is not required to grant employment to any job applicants who, in his opinion, are not qualified to perform the classification of work required.

4. If, within one week following the placing of a job order by the contractor with the State Employment Service, the State Employment Service is unable to refer any qualified job applicants to the contractor, or less than the number requested, the State Employment Service will forward a certificate to the contractor indicating the unavailability of applicants. Such certificate shall be made a part of the contractor's permanent project records. Upon receipt of this certificate, the contractor may employ persons who do not normally reside in the labor area to fill positions covered by the certificate, notwithstanding the provisions of subparagraph (1c) above.

5. The provisions of 23 CFR 633.207(e) allow the contracting agency to provide a contractual preference for the use of mineral resource materials native to the Appalachian region.

6. The contractor shall include the provisions of Sections 1 through 4 of this Attachment A in every subcontract for work which is, or reasonably may be, done as on-site work.