

STATE OF ILLINOIS
DEPARTMENT OF TRANSPORTATION

ROUTE NO.	SECTION	COUNTY	WORKS	SHEET	SHEET NO. 23
FAP 716	*	MACON	95	57	28 SHEETS
FED. ROAD DIST. NO.	ILLINOIS	FED. AID PROJECT			
CONTRACT NO. 74166					(130BR-1)B-1

* Granular or solid flux filled headed studs conforming to Article 1006.32 of the Std. Specs., automatically end welded.

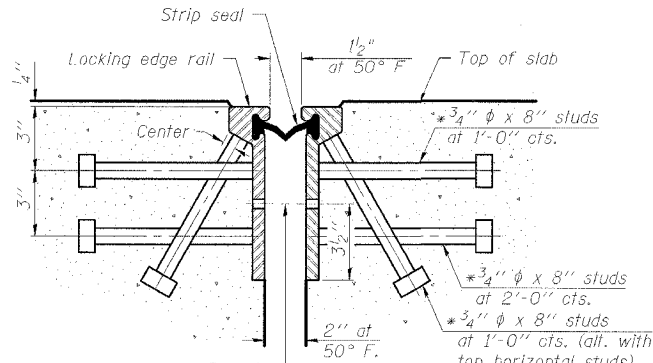

7/16" ϕ holes at 4'-0" cts. for 3/8" ϕ bolts. All bolts shall be burned, sawed, or chipped off flush with the plates after forms are removed, typ.

SECTION THRU
ROLLED RAIL JOINT

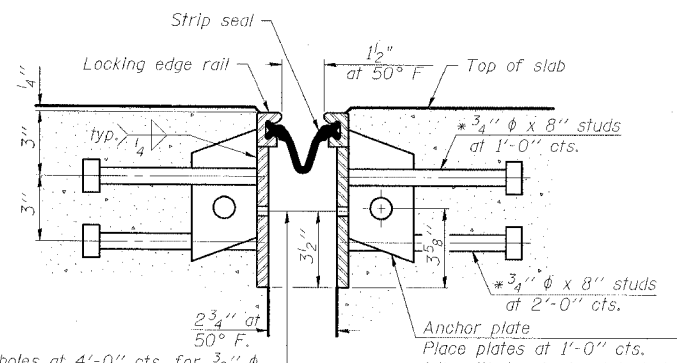

7/16" ϕ holes at 4'-0" cts. for 3/8" ϕ bolts. All bolts shall be burned, sawed, or chipped off flush with the plates after forms are removed, typ.

SECTION THRU
WELDED RAIL JOINT

Notes:
The strip seal shall be made continuous and shall have a minimum thickness of 1/4". The configuration of the strip seal shall match the configuration of the Locking Edge Rails. Open or "webbed" strip seal gland configurations are not permitted. The gland shall be sized for a maximum rated movement of 4 inches.
The height and thickness of the Locking Edge Rails shown are minimum dimensions. The actual configuration of the Locking Edge Rails and matching strip seal may vary from manufacturer to manufacturer. Flanged edge rails will not be allowed. Locking Edge Rails may be spliced at slope discontinuities and stage construction joints.
The manufacturer's recommended installation methods shall be followed. The joint opening and deck dimensions detailed on the superstructure are based on a rolled rail expansion joint. If the Contractor elects to use the welded rail expansion joint, the opening and deck dimensions shall be modified according to the dimensions detailed on this sheet. Required modifications shall be made at no additional cost to the State.
All steel components shall be galvanized after fabrication according to Article 520.03 of the Standard Specifications.

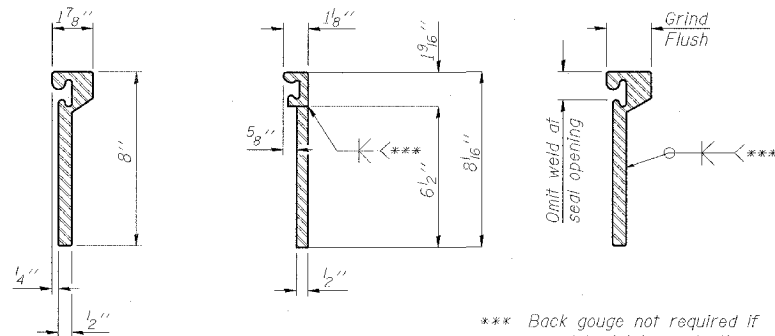

ROLLED
(EXTRUDED) RAIL WELDED RAIL

*** Back gouge not required if complete joint penetration is verified by mock-up.

LOCKING EDGE
RAIL SPLICE

The inside of the locking edge rail groove shall be free of weld residue.

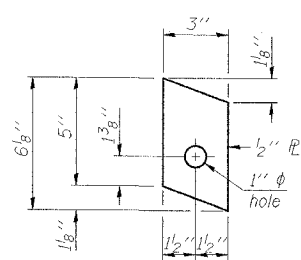

ANCHOR PLATE
(for welded rail)

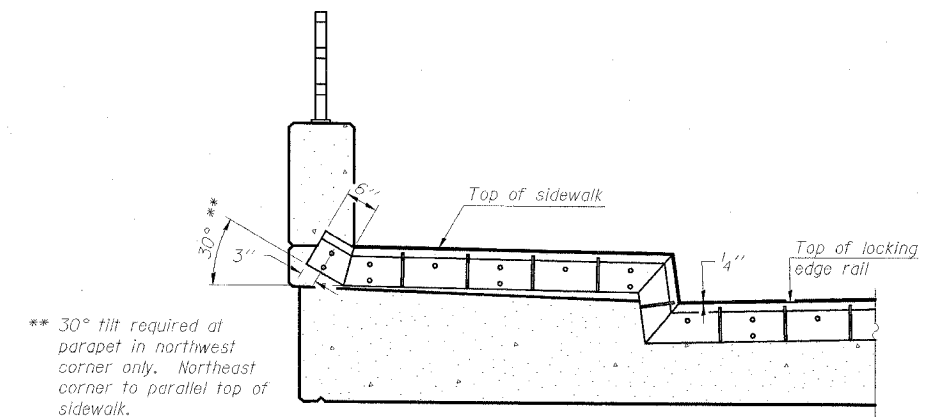

END TREATMENT AT SIDEWALK

Shorter plates with a single row of studs at 12" cts. may be necessary on medians which are shallower than 9". See manufacturer's recommendation.

LOCKING EDGE RAILS

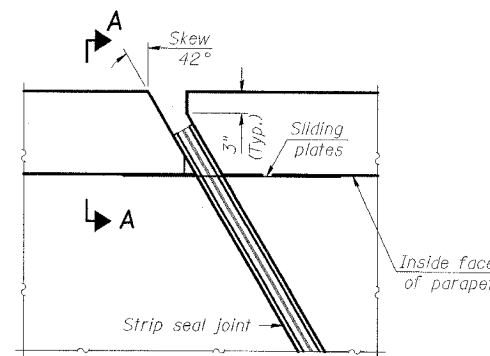

PLAN

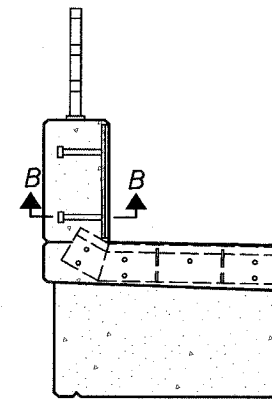

SECTION A-A

TYPICAL END TREATMENTS

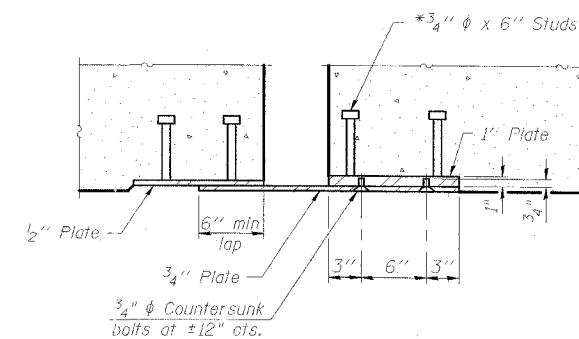

SECTION B-B

BILL OF MATERIAL

Item	Unit	Total
Preformed Joint Strip Seal	Foot	110

PERFORMED JOINT STRIP SEAL
IL ROUTE 48
OVER SPRING CREEK
FAP ROUTE 716-SECTION (130BR-1)B-1
MACON COUNTY
STATION 135+77.11
STRUCTURE NO. 058-0135

ESCA
CONSULTANTS, INC.

DESIGNED BY:	ELH	03/07
DRAWN BY:	HAS	03/07
CHECKED BY:	ELH	06/07
APPROVED BY:	RDP	06/07