

STATE OF ILLINOIS  
DEPARTMENT OF TRANSPORTATION  
DIVISION OF HIGHWAYS

# PLANS FOR PROPOSED FEDERAL AID HIGHWAY

VARIOUS STREETS  
KEDZIE AVENUE TO EAST VILLAGE LIMIT;  
115TH STREET TO 119TH STREET  
LOCAL AGENCY PAVEMENT PRESERVATION  
STREET RESURFACING  
PROJECT: HPP-3013(001)  
C-91-096-07  
SECTION NO.: 06-00026-00PV  
VILLAGE OF MERRIONETTE PARK  
COOK COUNTY

P. A. V. SHE.	SECTION	COUNTY	TOTAL SHEETS	SHEET NO.
	06-00026-00-PV	COOK	11	1
STA.		TO STA.		
FED. ROAD DIST. NO.	ILLINOIS	FED. AID PROJECT	HPP-3013(001)	

CONTRACT NO. 83958

- INDEX OF SHEETS**
1. COVER SHEET, INDEX OF SHEETS, LOCATION MAP  
INDEX OF STATE STANDARDS
  2. SUMMARY OF QUANTITIES & GENERAL NOTES
  3. TYPICAL CROSS SECTION
  - 4.-10. ROADWAY AND PAVEMENT MARKING PLANS
  11. DISTRICT ONE PAVEMENT MARKINGS

- STATE STANDARDS**
- |           |   |
|-----------|---|
| 000001-04 | STANDARD SYMBOLS, ABBREVIATIONS AND PATTERNS                        |
| 424001-04 | CURB RAMPS FOR SIDEWALKS  |
| 442201-02 | CLASS C AND D PATCHES   |
| 606001-03 | CONCRETE CURB TYPE B AND COMBINATION<br>CURB AND GUTTER             |
| 701501-03 | URBAN LANE CLOSURE, 2-L, 2-W, UNDIVIDED                             |
| 701801-03 | LANE CLOSURE, MULTILANE, 1W OR 2W, CROSSWALK<br>OR SIDEWALK CLOSURE |
| 702001-06 | TRAFFIC CONTROL DEVICES   |
| 780001-01 | TYPICAL PAVEMENT MARKINGS   |

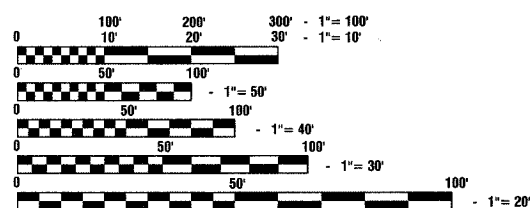
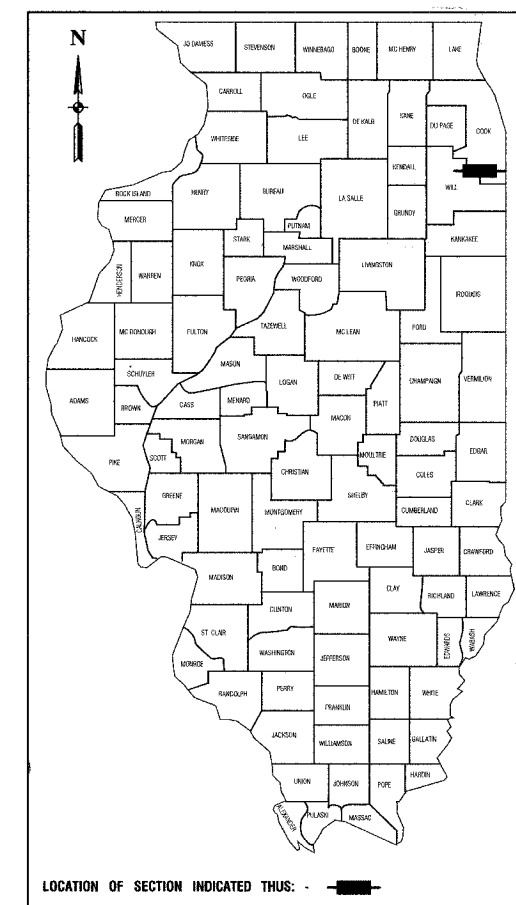

FULL SIZE PLANS HAVE BEEN PREPARED USING STANDARD ENGINEERING SCALES, REDUCED SIZED PLANS WILL NOT CONFORM TO STANDARD SCALES, IN MAKING MEASUREMENTS ON REDUCED PLANS, THE ABOVE SCALES MAY BE USED.

J. U. L. I. E.  
JOINT UTILITY LOCATION INFORMATION FOR EXCAVATION  
1-800-892-0123

CONTRACT NO. 83958

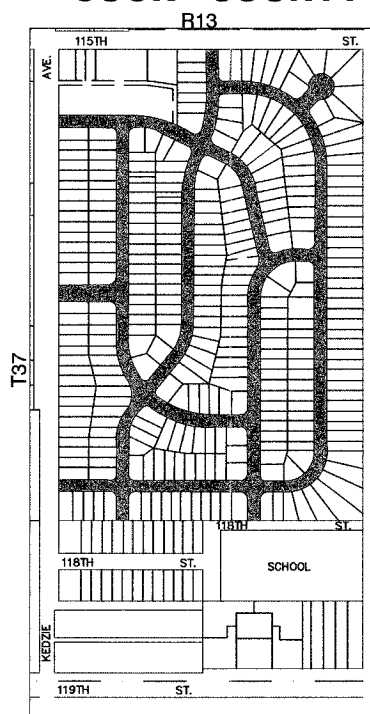

LOCATION MAP

GROSS LENGTH OF PROJECT: 11446 FEET (2.17 MILES)  
NET LENGTH OF PROJECT: 11446 FEET (2.17 MILES)

TRAFFIC DATA  
2007 ADT = 400  
2030 ADT = 400  
SPEED LIMIT = 20 MPH

DESIGN DESIGNATION  
LOCAL ROAD

STATE OF ILLINOIS  
DEPARTMENT OF TRANSPORTATION  
DIVISION OF HIGHWAYS

APPROVED: May 31 2007  
*Alan C. Helm*  
DIRECTOR OF PUBLIC WORKS, VILLAGE OF MERRIONETTE PARK

PASSED: July 20 2007  
*C. A. S. CHRISTOPHER HOLT*  
REGION ONE ENGINEER OF LOCAL ROADS & STREETS

RELEASING FOR  
BID BASED ON  
LIMITED REVIEW: July 20 2007  
*Miane O'Keefe*  
DEPUTY DIRECTOR OF HIGHWAYS, REGION ONE ENGINEER

PRINTED BY AUTHORITY OF THE STATE OF ILLINOIS

PREPARED BY OR UNDER THE  
DIRECT SUPERVISION OF:

*William P. Dolan*  
May 31, 2007

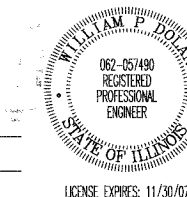

I.D.O.T. FEDERAL AID DESIGN ENGINEER: KEVIN STALLWORTH 847-705-4169  
CONSULTANTS: ROBINSON ENGINEERING, LTD. 708-331-6700

F. A. U. NO.	SECTION	COUNTY	TOTAL SHEETS	SHEET NO.
	06-00026-00-PV	COOK	11	2
STA.	TO STA.			
FED. ROAD DIST. NO.	ILLINOIS	FED. AID PROJECT	HPP-3013(001)	

**CONTRACT NO. 83958**

SUMMARY OF QUANTITIES					PAVEMENT	MARKINGS	SIGNS	LANDSCAPE	LIGHTS	SIGNALS	TRAINING
S.I.	CODE NO.	PAY ITEM	UNIT	QUAN	CONSTRUCTION TYPE CODE						
					I000	SFTY-1D	Y002-1C	Y003	Y030-1E	Y031	Y080
	25200650	SODDING, SALT TOLERANT (SPECIAL)	SQ YD	2000	2000						
	35800100	PREPARATION OF BASE	SQ YD	400	400						
	40600100	BITUMINOUS MATERIALS (PRIME COAT)	GALLON	3151	3151						
	40600300	AGGREGATE (PRIME COAT)	TON	63	63						
	40600825	POLYMERIZED LEVELING BINDER (MACHINE METHOD), N50	TON	640	640						
	40603310	HOT-MIX ASPHALT SURFACE COURSE, MIX "C", N50	TON	2647	2647						
	42300200	PORTLAND CEMENT CONCRETE DRIVEWAY PAVEMENT, 6 INCH	SQ YD	311	311						
	42400200	PORTLAND CEMENT CONCRETE SIDEWALK 5 INCH	SQ FT	4076	4076						
	42400800	DETECTABLE WARNINGS	SQ FT	384	384						
	44000157	HOT-MIX ASPHALT SURFACE REMOVAL, 2"	SQ YD	31507	31507						
	44000200	DRIVEWAY PAVEMENT REMOVAL	SQ YD	1079	1079						
	44000500	COMBINATION CURB AND GUTTER REMOVAL	FOOT	6029	6029						
	44000600	SIDEWALK REMOVAL	SQ FT	4076	4076						
	44201717	CLASS D PATCHES, TYPE II, 6 INCH	SQ YD	43	43						
	44201721	CLASS D PATCHES, TYPE III, 6 INCH	SQ YD	41	41						
	44201723	CLASS D PATCHES, TYPE IV, 6 INCH	SQ YD	61	61						
	60250400	CATCH BASINS TO BE ADJUSTED WITH NEW TYPE 1 FRAME, OPEN LID	EACH	2	2						
	60252800	CATCH BASINS TO BE RECONSTRUCTED	EACH	7	7						
	60257900	MANHOLES TO BE RECONSTRUCTED	EACH	3	3						
	60266600	VALVE BOXES TO BE ADJUSTED	EACH	2	2						
	60300305	FRAMES AND LIDS TO BE ADJUSTED	EACH	144	144						
	60611600	COMBINATION CONCRETE CURB AND GUTTER, (SPECIAL)	FOOT	6029	6029						
	67100100	MOBILIZATION	L SUM	1	1						
	70102620	TRAFFIC CONTROL AND PROTECTION, STANDARD 701501	L SUM	1	1						
	70102640	TRAFFIC CONTROL AND PROTECTION, STANDARD 701801	L SUM	1	1						
*	78000600	THERMOPLASTIC PAVEMENT MARKING - LINE 12"	FOOT	200		200					
*	78000650	THERMOPLASTIC PAVEMENT MARKING - LINE 24"	FOOT	50		50					
	Z0000940	AGGREGATE FOR DRIVEWAY MAINTENANCE	TON	100	100						
	XX006806	HOT-MIX ASPHALT DRIVEWAY PAVEMENT	SQ YD	768	768						

\* - INDICATES SPECIALTY ITEMS

**GENERAL NOTES**

ROBINSON ENGINEERING FIELD OFFICE SHALL BE NOTIFIED TWO (2) WORKING DAYS PRIOR TO CONSTRUCTION. CALL (708) 331-6700

THE CONTRACTOR SHALL PROVIDE AND INSTALL TWO (2) WEIGHTED SANDBAGS ON EACH TYPE 1 AND TYPE 2 BARRICADE USED. ONE (1) WEIGHTED SANDBAG SHALL BE INSTALLED ON EACH BOTTOM RAIL.

THE REMOVAL OF ANY DRIVEWAYS, PAVEMENT, CURB, ETC. SHALL BE ACCOMPLISHED BY MEANS OF A SAW CUT JOINT, AT THE DIRECTION OF THE ENGINEER. THIS WORK SHALL NOT BE PAID FOR SEPARATELY, BUT SHALL BE INCLUDED IN THE UNIT PRICE BID FOR THE VARIOUS REMOVAL ITEMS.

WHEN, IN THE CONSTRUCTION OPERATION, ANY LOOSE MATERIAL IS DEPOSITED IN THE FLOW LINE OF DITCHES, GUTTERS OR OTHER DRAINAGE STRUCTURES SO THAT THE NATURAL FLOW OF WATER IS OBSTRUCTED, IT SHALL BE REMOVED AT THE CLOSE OF EACH DAY BY THE CONTRACTOR AT HIS EXPENSE. AT THE CONCLUSION OF THE CONSTRUCTION OPERATIONS, ALL DRAINAGE STRUCTURES SHALL BE FREE FROM ALL DIRT AND DEBRIS. THIS WORK SHALL NOT BE PAID FOR SEPARATELY BUT SHALL BE CONSIDERED INCIDENTAL TO THE CONTRACT.

BEFORE STARTING ANY EXCAVATION, THE CONTRACTOR SHALL CALL J.U.L.I.E. AT (800) 892-0123 FOR FIELD LOCATIONS OF BURIED ELECTRIC, COMMUNICATIONS, AND GAS UTILITIES. (48 HOUR NOTIFICATION REQUIRED.)

IT SHALL BE THE CONTRACTORS RESPONSIBILITY TO VERIFY ALL DIMENSIONS AND CONDITIONS EXISTING IN THE FIELD PRIOR TO CONSTRUCTION AND ORDERING OF MATERIALS.

SCHEDULES INCLUDED IN THE PLANS HAVE BEEN PREPARED FROM FIELD NOTES. EXACT LOCATIONS FOR PATCHING SHALL BE DETERMINED IN THE FIELD BY THE ENGINEER.

AREAS DISTURBED BY CONSTRUCTION SHALL BE KEPT TO A MINIMUM. ALL AREAS DISTURBED UNNECESSARILY SHALL BE RESTORED AT THE CONTRACTORS EXPENSE.

UTILITIES INDICATED ON THE PLANS ARE PROVIDED OR THE CONTRACTORS USE AND ARE BASED UPON INFORMATION AVAILABLE AT THE TIME OF THE ADVERTISEMENT FOR BIDS. THE OWNER AND ENGINEER DO NOT GUARANTEE THE ACCURACY OF THE UTILITY INFORMATION.

ITEMS OF WORK LISTED IN THE SUMMARY OF QUANTITIES NOT SPECIFICALLY CALLED OUT ON THE PLANS SHALL BE PERFORMED AS DIRECTED BY THE ENGINEER.

ANY REFERENCE TO THE STANDARDS THROUGHOUT THE PLANS OR SPECIAL PROVISIONS SHALL BE INTERPRETED TO BE THE LATEST STANDARDS OF THE ILLINOIS DEPARTMENT OF TRANSPORTATION.

THE NOMINAL THICKNESS OF HOT-MIX ASPHALT MIXTURE STATED IN THE SPECIFICATIONS IS THE NOMINAL THICKNESS. DEVIATIONS FROM THE NOMINAL THICKNESS WILL BE PERMITTED WHEN SUCH DEVIATIONS OCCUR DUE TO IRREGULARITIES IN THE EXISTING SURFACE OR BASE ON WHICH THE HOT-MIX ASPHALT SURFACE IS PLACED.

CONTRACTOR SHALL MILL EXISTING PAVEMENT PRIOR TO PATCHING.

REVISIONS	
NAME	DATE

ILLINOIS DEPARTMENT OF TRANSPORTATION

VARIOUS STREETS

SCHEDULE OF QUANTITIES  
AND GENERAL NOTES

SCALE: VERT. NA  
HORIZ. NA  
DATE 03/22/07

DRAWN BY JZ  
CHECKED BY WD

F. A. U. NO.	SECTION	COUNTY	TOTAL SHEETS	SHEET NO.
	06-00026-00-PV	COOK	11	3
STA.	TO STA.			
FED. ROAD DIST. NO.	BLADE	FED. AID PROJECT	HPP-3013(001)	

**CONTRACT NO. 83958**

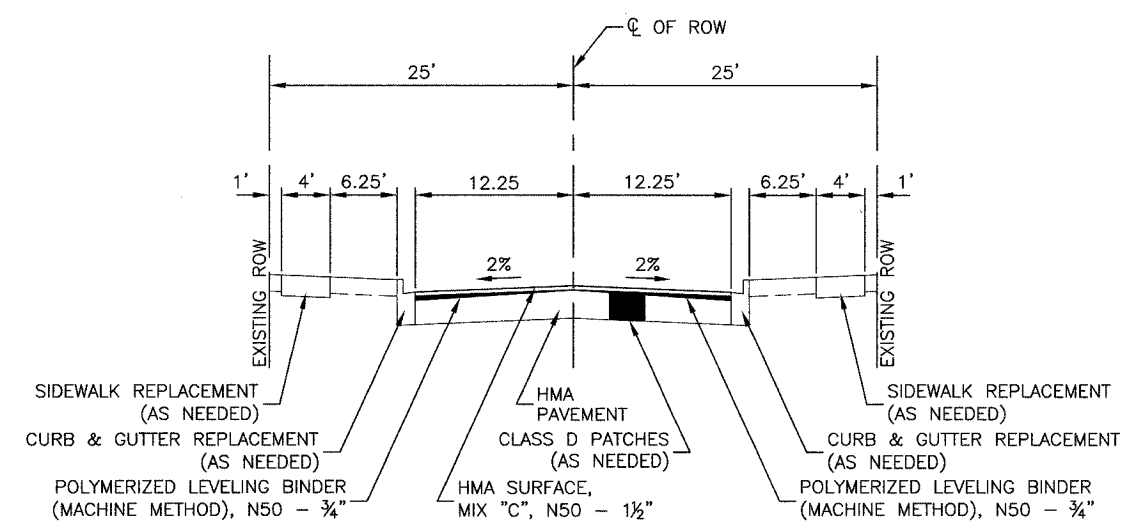

**PROPOSED TYPICAL SECTION**  
VARIOUS STREETS

**HOT-MIX ASPHALT MIXTURE REQUIREMENTS**

MIXTURE TYPE	AC TYPE	VOIDS
HOT-MIX ASPHALT SURFACE COURSE, MIX C, N50 (IL-9.5mm)	PG 64-22	4% @ 50 GYR
POLYMERIZED LEVELING BINDER (MACHINE METHOD), N50 (IL-4.75mm)	SBS/SBR PG 76-28/-22	4% @ 50 GYR
CLASS D PATCHES, TYPE II, III, IV, 6 INCH (BINDER IL-19MM)	*PG 64-22	4% @ 70 GYR
DRIVEWAYS		
HOT-MIX ASPHALT SURFACE COURSE, MIX "C", N50 (IL 9.5mm)-2"	PG 64-22	4% @ 50 GYR
HOT-MIX ASPHALT BASE COURSE (BINDER IL-19 mm); PE-6", CE-8"	*PG 64-22	4% @ 50 GYR

- NOTE:
1. THE UNIT WEIGHT USED TO CALCULATE ALL HOT-MIX ASPHALT SURFACE MIXTURE QUANTITIES IS 112 LBS/SY/IN.
  2. \*WHEN RAP EXCEEDS 20%, THE NEW ASPHALT BINDER IN THE MIX SHALL BE PG 58-22.

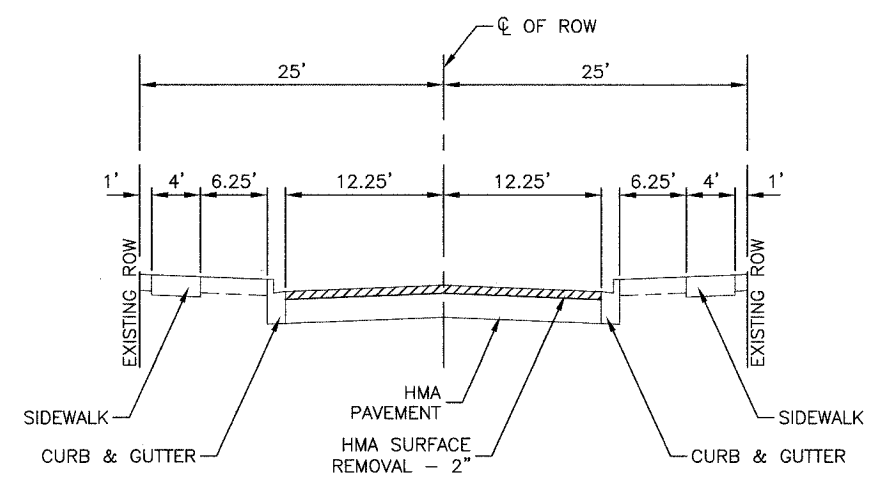

**EXISTING TYPICAL SECTION**  
VARIOUS STREETS

REVISIONS	
NAME	DATE

ILLINOIS DEPARTMENT OF TRANSPORTATION  
VARIOUS STREETS  
TYPICAL CROSS SECTIONS

SCALE: VERT. NA  
HORIZ. NA  
DATE 03/22/07

DRAWN BY JZ  
CHECKED BY WD

F. A. NO.	SECTION	COUNTY	TOTAL SHEETS	SHEET NO.
	06-00026-00-PV	COOK	11	4
STA.	TO STA.			
FED. ROAD DIST. NO.	KLINGS	FED. AID PROJECT	HPP-3013(001)	

**CONTRACT NO. 83958**

**STRIPING LEGEND:**

- ① THERMOPLASTIC PAVEMENT MARKING-12" (WHITE CROSSWALK)
- ② THERMOPLASTIC PAVEMENT MARKING-24" (WHITE STOP BAR)

**LEGEND:**

- P.C.C. SIDEWALK REMOVAL AND REPLACEMENT
- CONCRETE CURB AND GUTTER REMOVAL AND REPLACEMENT
- LIMITS OF HOT-MIX ASPHALT SURFACE REMOVAL, 2"
- CLASS D PATCHES
- HOT-MIX ASPHALT DRIVEWAY REMOVAL AND REPLACEMENT
- P.C.C. DRIVEWAY REMOVAL AND REPLACEMENT

**LOCATION MAP**

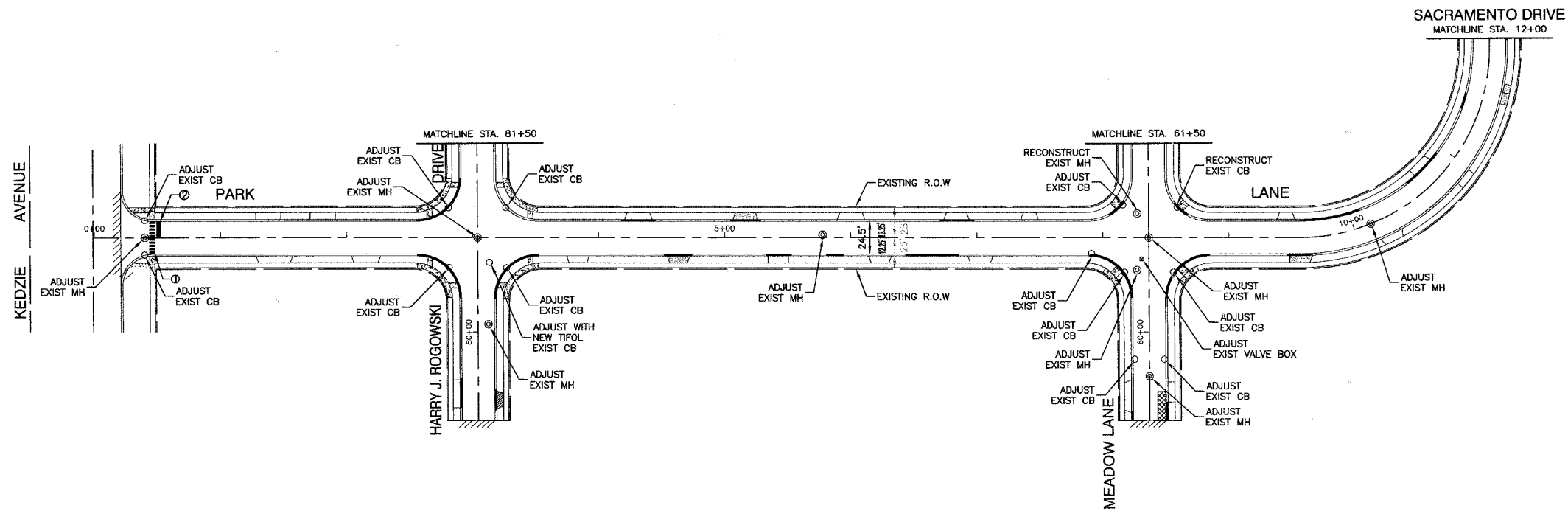
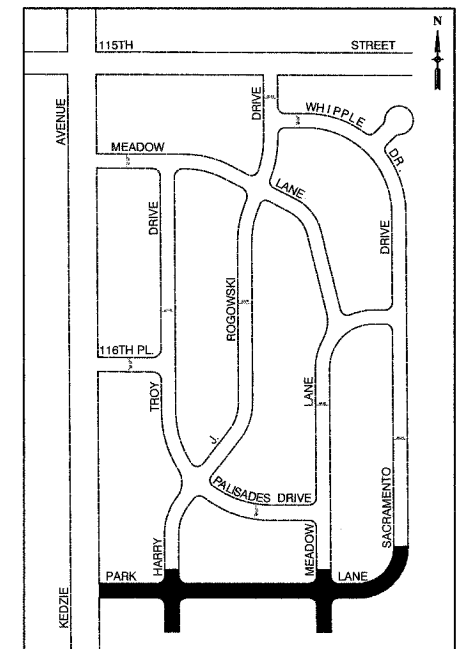

REVISIONS	
NAME	DATE

ILLINOIS DEPARTMENT OF TRANSPORTATION

**LAPP RESURFACING**

**PARK LANE**  
KEDZIE AVENUE TO STA. 12+00

SCALE: VERT. N/A  
HORIZ. 1" = 50'

DATE 03/22/07

DRAWN BY JZ  
CHECKED BY WD

F. A. NO.	SECTION	COUNTY	TOTAL SHEETS	SHEET NO.
06-00026-00-PV	06-00026-00-PV	COOK	11	5
STA.	TO STA.			
FED. ROAD DIST. NO.	ILLINOIS	FED. AID PROJECT	HPP-3013(001)	

CONTRACT NO. 83958

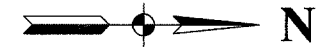

**STRIPING LEGEND:**

- ① THERMOPLASTIC PAVEMENT MARKING-12" (WHITE CROSSWALK)
- ② THERMOPLASTIC PAVEMENT MARKING-24" (WHITE STOP BAR)

**LEGEND:**

- P.C.C. SIDEWALK REMOVAL AND REPLACEMENT
- CONCRETE CURB AND GUTTER REMOVAL AND REPLACEMENT
- LIMITS OF HOT-MIX ASPHALT SURFACE REMOVAL, 2'
- CLASS D PATCHES
- HOT-MIX ASPHALT DRIVEWAY REMOVAL AND REPLACEMENT
- P.C.C. DRIVEWAY REMOVAL AND REPLACEMENT

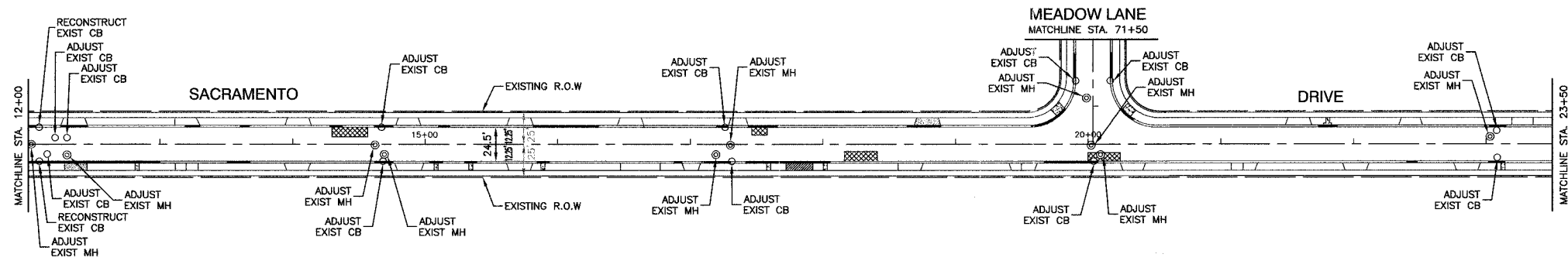

**LOCATION MAP**

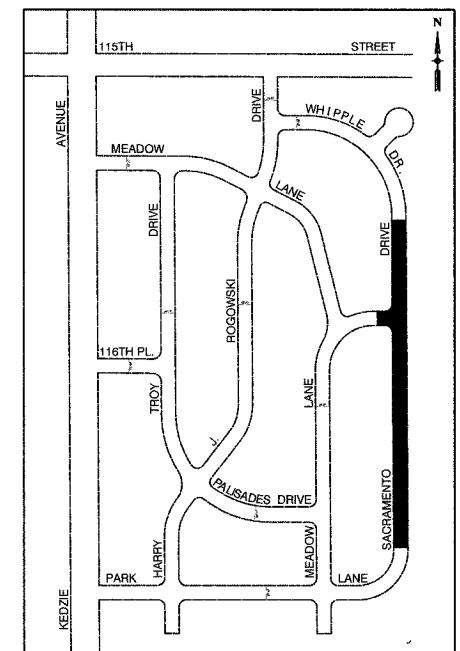

REVISIONS	
NAME	DATE

ILLINOIS DEPARTMENT OF TRANSPORTATION

**LAPP RESURFACING**

**SACRAMENTO DRIVE**

**STA. 12+00 TO STA. 23+50**

VERT. N/A  
SCALE: HORIZ. 1" = 50'  
DATE 03/22/07

DRAWN BY JZ  
CHECKED BY WD

F. A. NO.	SECTION	COUNTY	TOTAL SHEETS	SHEET NO.
	06-00026-00-PV	COOK	11	6
STA.	TO STA.			
FED. ROAD DIST. NO.	ILLINOIS	FED. AID PROJECT	HPP-3013(001)	

CONTRACT NO. 83958

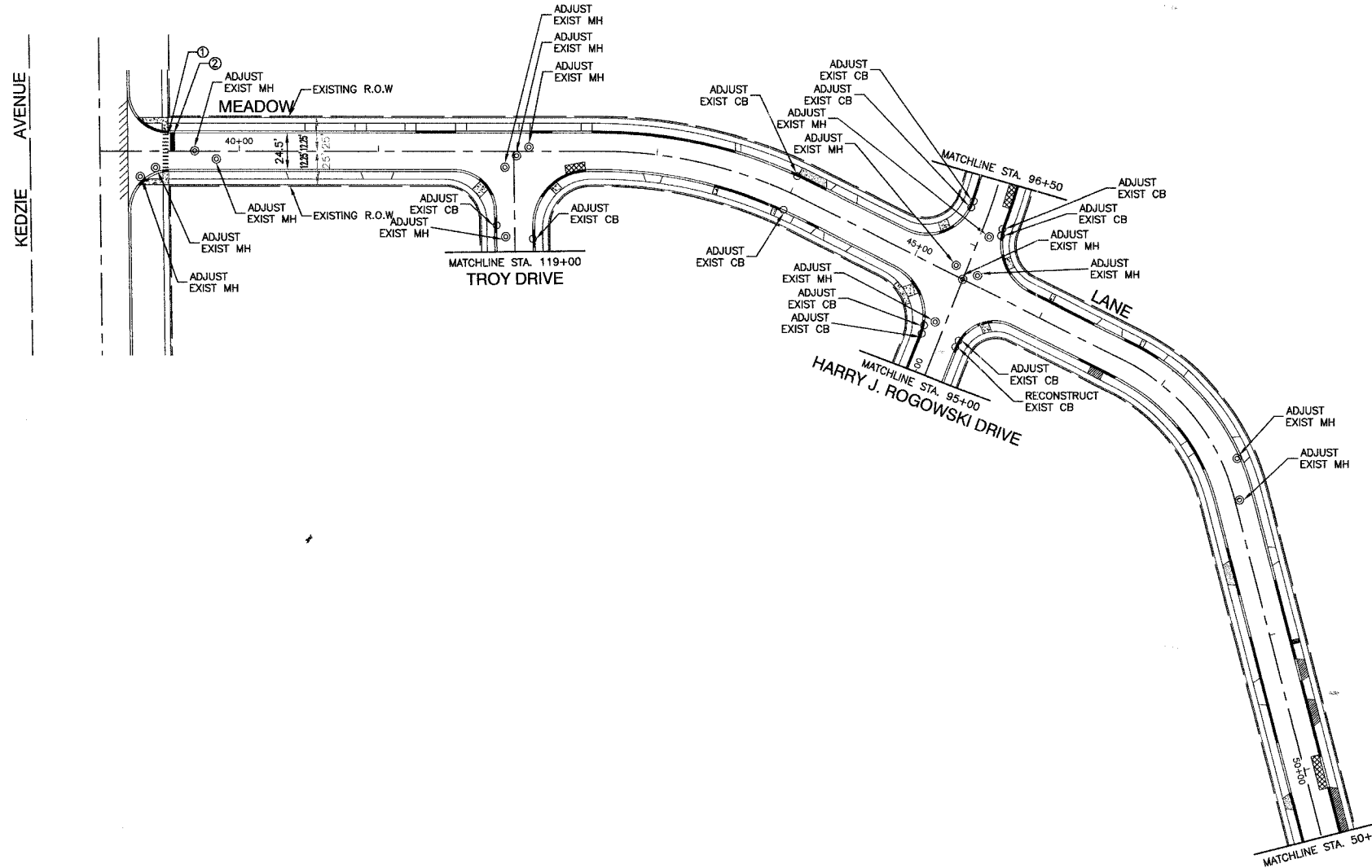

**STRIPING LEGEND:**

- ① THERMOPLASTIC PAVEMENT MARKING-12" (WHITE CROSSWALK)
- ② THERMOPLASTIC PAVEMENT MARKING-24" (WHITE STOP BAR)

**LEGEND:**

- P.C.C. SIDEWALK REMOVAL AND REPLACEMENT
- CONCRETE CURB AND GUTTER REMOVAL AND REPLACEMENT
- LIMITS OF HOT-MIX ASPHALT SURFACE REMOVAL, 2'
- CLASS D PATCHES
- HOT-MIX ASPHALT DRIVEWAY REMOVAL AND REPLACEMENT
- P.C.C. DRIVEWAY REMOVAL AND REPLACEMENT

**LOCATION MAP**

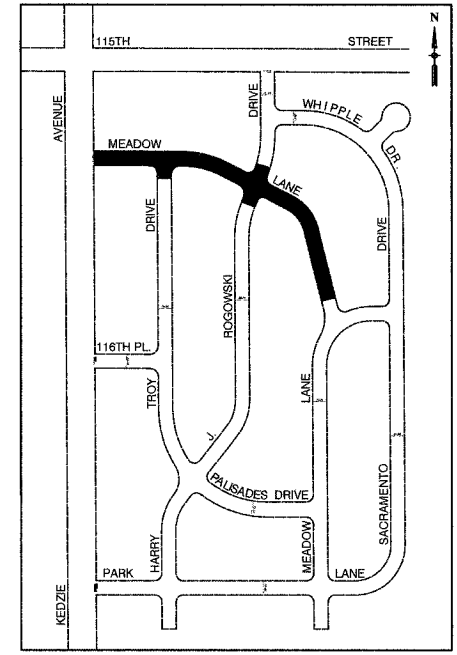

REVISIONS	
NAME	DATE

ILLINOIS DEPARTMENT OF TRANSPORTATION

LAPP RESURFACING

MEADOW LANE  
KEDZIE AVENUE TO STA. 50+50

SCALE: VERT. N/A  
HORIZ. 1" = 50'

DATE 03/22/07

DRAWN BY JZ  
CHECKED BY WD

F. A. SHEET	SECTION	COUNTY	TOTAL SHEETS	SHEET NO.
	06-00026-00-PV	COOK	11	7
STA.	TO STA.			
FED. ROAD DIST. NO.	ILLINOIS	FED. AID PROJECT	HPP-3013(001)	

CONTRACT NO. 83958



**STRIPING LEGEND:**

- ① THERMOPLASTIC PAVEMENT MARKING-12" (WHITE CROSSWALK)
- ② THERMOPLASTIC PAVEMENT MARKING-24" (WHITE STOP BAR)

**LEGEND:**

- P.C.C. SIDEWALK REMOVAL AND REPLACEMENT
- CONCRETE CURB AND GLITTER REMOVAL AND REPLACEMENT
- LIMITS OF HOT-MIX ASPHALT SURFACE REMOVAL, 2'
- CLASS D PATCHES
- HOT-MIX ASPHALT DRIVEWAY REMOVAL AND REPLACEMENT
- P.C.C. DRIVEWAY REMOVAL AND REPLACEMENT

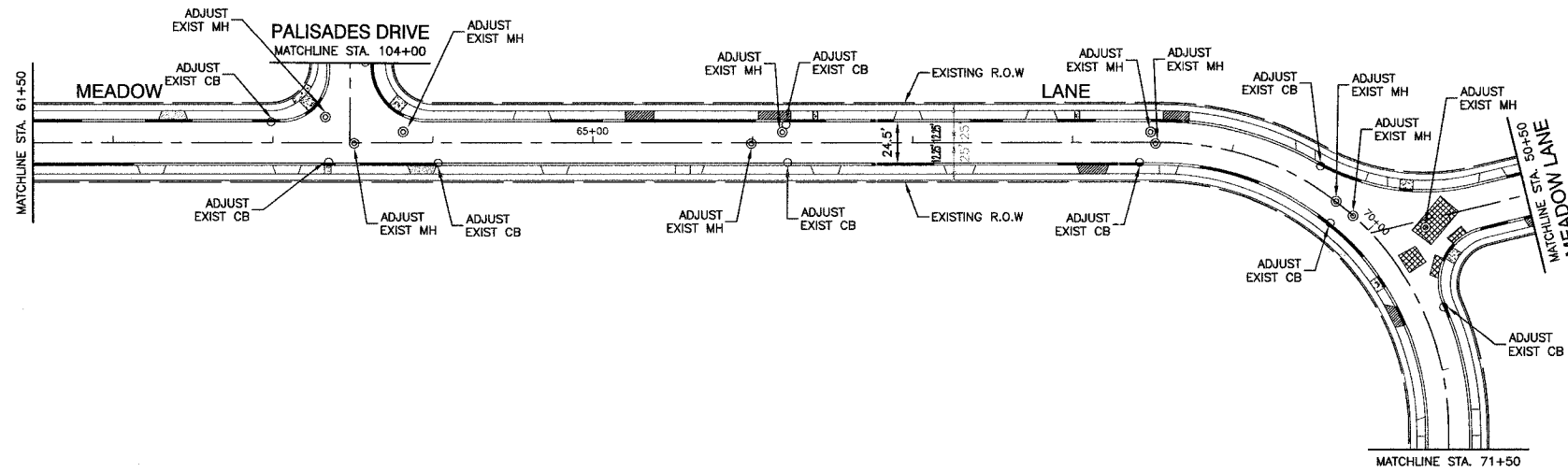

**LOCATION MAP**

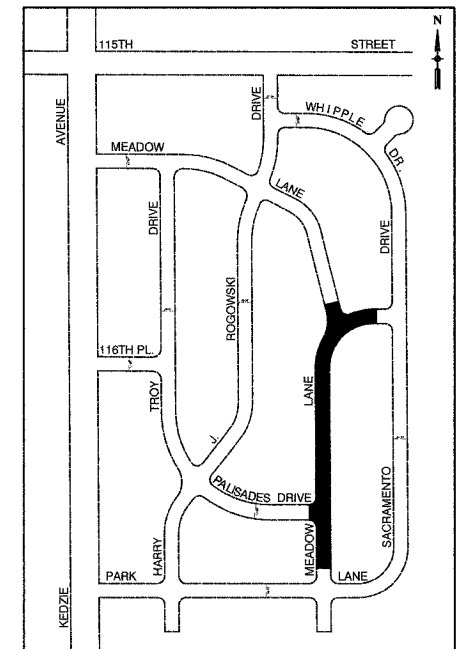

REVISIONS	
NAME	DATE

ILLINOIS DEPARTMENT OF TRANSPORTATION

**LAPP RESURFACING**

**MEADOW LANE**

**STA. 61+50 TO STA. 71+50**

SCALE: VERT. N/A  
 HORIZ. 1" = 50'  
 DATE 03/22/07

DRAWN BY JZ  
 CHECKED BY WD

F.A. SHEET	SECTION	COUNTY	TOTAL SHEETS	SHEET NO.
	06-00026-00-PV	COOK	11	8
STA.	TO STA.			
FED. ROAD DIST. NO.	BLANK	FED. AID PROJECT	HPP-3013(001)	

CONTRACT NO. 83958



**STRIPING LEGEND:**

- ① THERMOPLASTIC PAVEMENT MARKING-12" (WHITE CROSSWALK)
- ② THERMOPLASTIC PAVEMENT MARKING-24" (WHITE STOP BAR)

**LEGEND:**

- P.C.C. SIDEWALK REMOVAL AND REPLACEMENT
- CONCRETE CURB AND GUTTER REMOVAL AND REPLACEMENT
- LIMITS OF HOT-MIX ASPHALT SURFACE REMOVAL, 2"
- CLASS D PATCHES
- HOT-MIX ASPHALT DRIVEWAY REMOVAL AND REPLACEMENT
- P.C.C. DRIVEWAY REMOVAL AND REPLACEMENT

**LOCATION MAP**

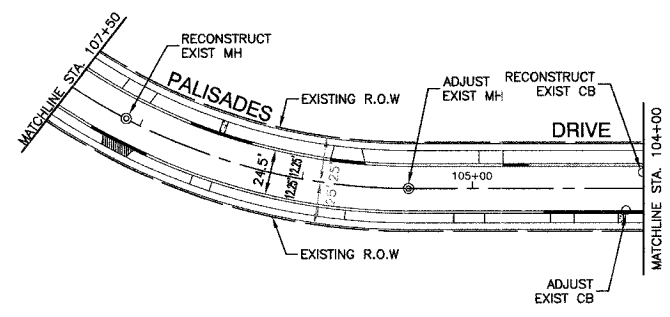
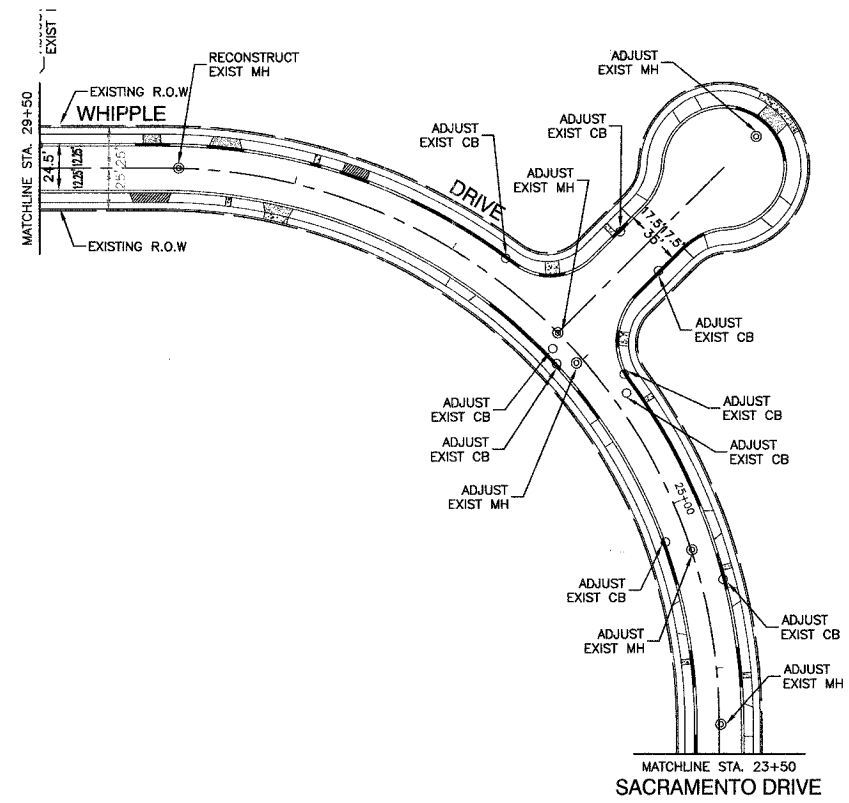
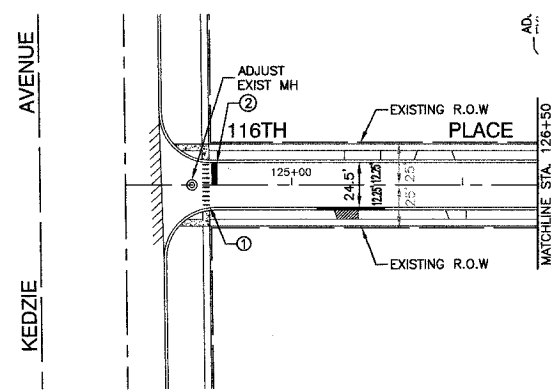
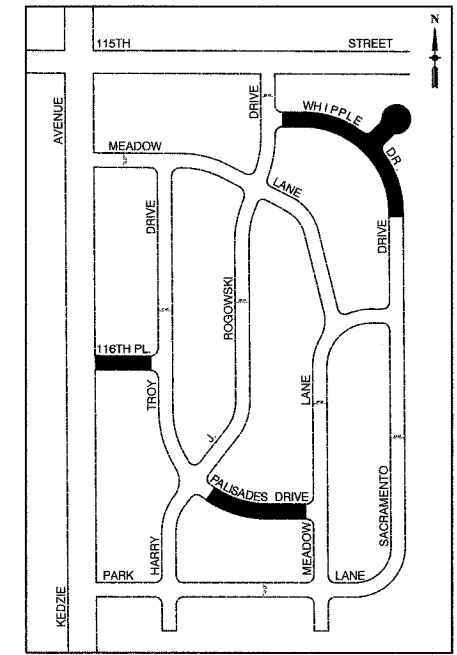

REVISIONS	
NAME	DATE

ILLINOIS DEPARTMENT OF TRANSPORTATION

LAPP RESURFACING

116TH PLACE, PALISADES DRIVE, & WHIPPLE DRIVE

VERT. NA  
 SCALE: HORIZ 1" = 50'  
 DATE 03/22/07

DRAWN BY JZ  
 CHECKED BY WD



SECTION 24, TOWNSHIP 37, RANGE 13

F. A. SHEET	SECTION	COUNTY	TOTAL SHEETS	SHEET NO.
	06-00026-00-PV	COOK	11	9
STA.	TO STA.			
FED. ROAD DIST. NO.	ALJMS	FED. AID PROJECT	HPP-3013(001)	

CONTRACT NO. 83958

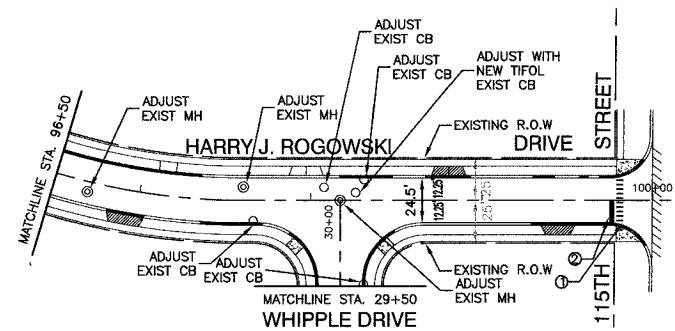
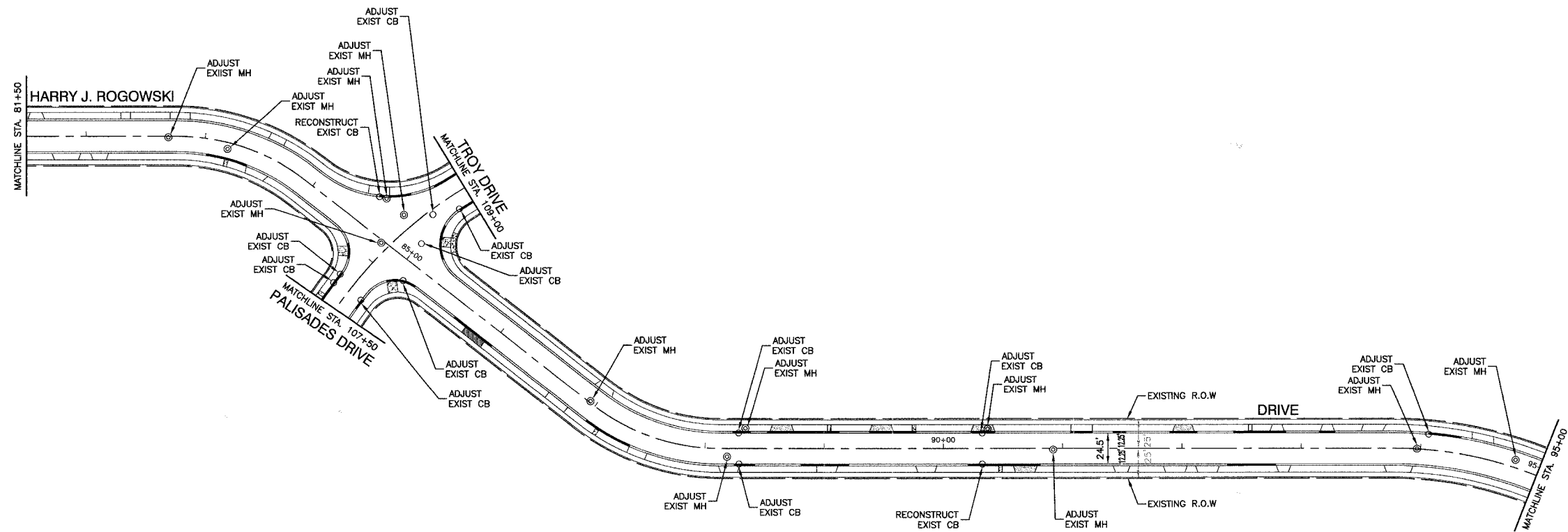

STRIPING LEGEND:

- ① THERMOPLASTIC PAVEMENT MARKING-12" (WHITE CROSSWALK)
- ② THERMOPLASTIC PAVEMENT MARKING-24" (WHITE STOP BAR)

LEGEND:

- P.C.C. SIDEWALK REMOVAL AND REPLACEMENT
- CONCRETE CURB AND GUTTER REMOVAL AND REPLACEMENT
- LIMITS OF HOT-MIX ASPHALT SURFACE REMOVAL, 2"
- CLASS D PATCHES
- HOT-MIX ASPHALT DRIVEWAY REMOVAL AND REPLACEMENT
- P.C.C. DRIVEWAY REMOVAL AND REPLACEMENT

LOCATION MAP

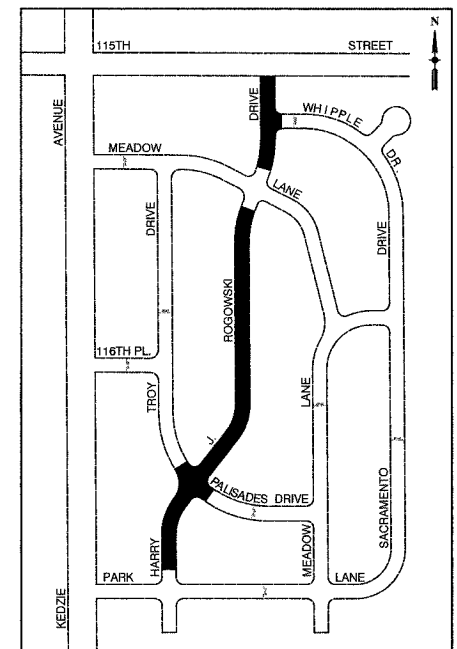

REVISIONS	
NAME	DATE

ILLINOIS DEPARTMENT OF TRANSPORTATION

LAPP RESURFACING  
 HARRY J. ROGOWSKI DRIVE  
 STA. 81+50 TO STA. 95+00 &  
 STA. 96+50 TO 115TH STREET

SCALE: VERT. N/A  
 HORIZ. 1" = 50'

DATE 03/22/07

DRAWN BY JZ  
 CHECKED BY WD

F. A. U. NO.	SECTION	COUNTY	TOTAL SHEETS	SHEET NO.
	06-0026-00-PV	COOK	11	10
STA. 109+00	TO STA. 119+00			
FED. ROAD DIST. NO.	LINE	FED. AID PROJECT	HPP-3013(001)	

**CONTRACT NO. 83958**



**STRIPING LEGEND:**

- ① THERMOPLASTIC PAVEMENT MARKING-12" (WHITE CROSSWALK)
- ② THERMOPLASTIC PAVEMENT MARKING-24" (WHITE STOP BAR)

**LEGEND:**

- P.C.C. SIDEWALK REMOVAL AND REPLACEMENT
- CONCRETE CURB AND GUTTER REMOVAL AND REPLACEMENT
- LIMITS OF HOT-MIX ASPHALT SURFACE REMOVAL, 2"
- CLASS D PATCHES
- HOT-MIX ASPHALT DRIVEWAY REMOVAL AND REPLACEMENT
- P.C.C. DRIVEWAY REMOVAL AND REPLACEMENT

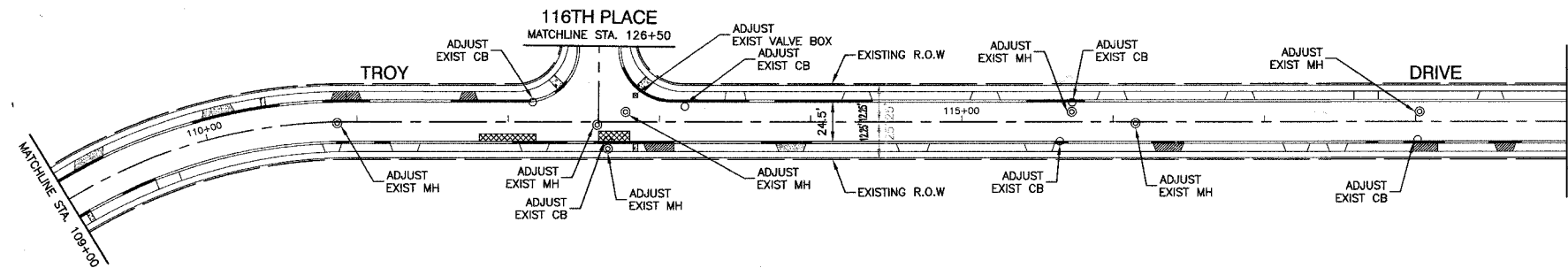

**LOCATION MAP**

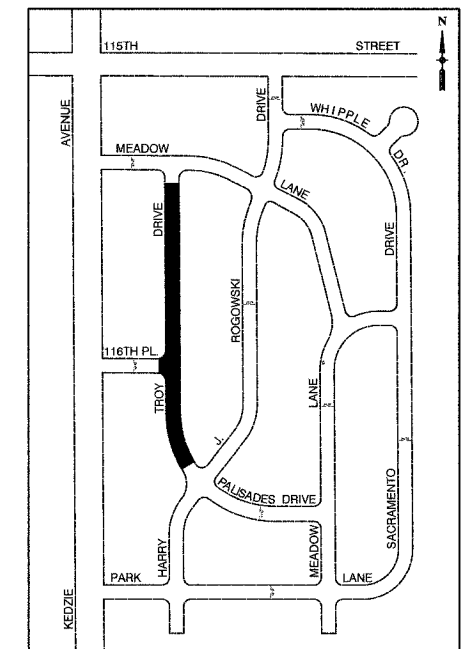

REVISIONS	
NAME	DATE

ILLINOIS DEPARTMENT OF TRANSPORTATION

**LAPP RESURFACING**

TROY DRIVE  
STA. 109+00 TO STA. 119+00

SCALE: VERT. 1" = 50'  
HORIZ. 1" = 50'

DATE 03/22/07

DRAWN BY JZ  
CHECKED BY WD

FAU. RITE.	SECTION	COUNTY	TOTAL SHEETS	SHEET NO.
	06-00026-00-PV	COOK	11	11
STA.	TO STA.			
FED. ROAD DIST. NO.	ILLINOIS	FED. AID PROJECT HPP-3013(001)		

**CONTRACT NO.83958**

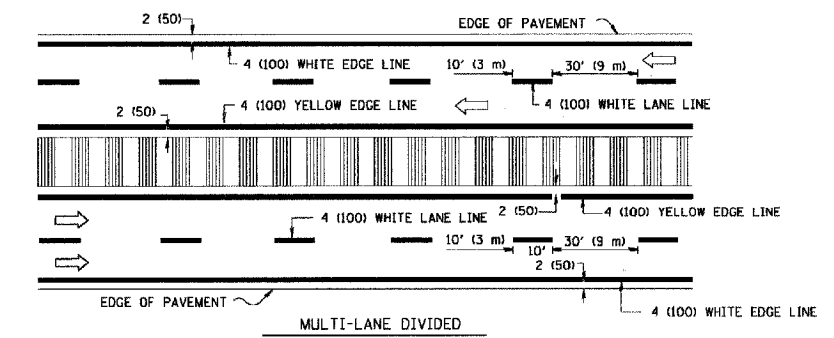
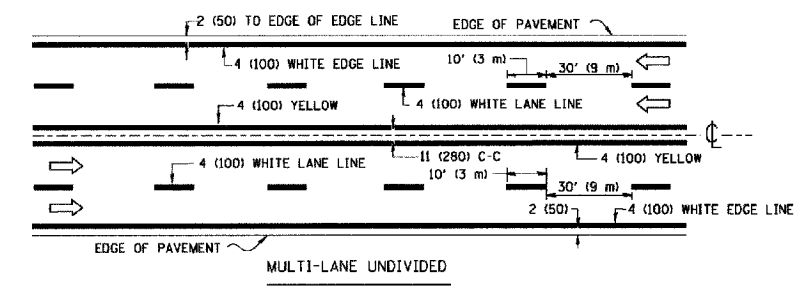
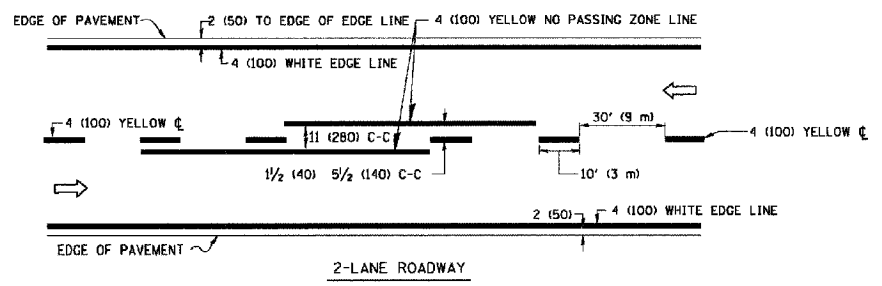

NOTE: MEDIANS WITH BARRIER CURB DO NOT REQUIRE AN EDGE LINE

**TYPICAL LANE AND EDGE LINE MARKING**

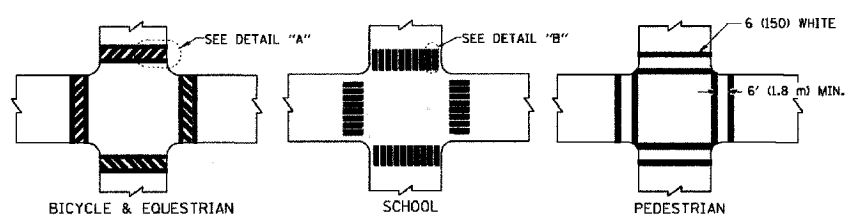

**TYPICAL CROSSWALK MARKING**

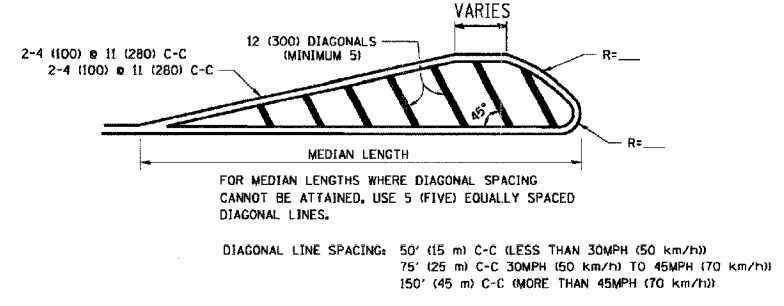
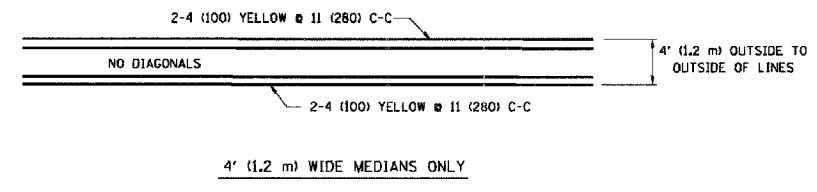

DIAGONAL LINE SPACING: 50' (15 m) C-C (LESS THAN 30MPH (50 km/h))  
75' (25 m) C-C 30MPH (50 km/h) TO 45MPH (70 km/h)  
150' (45 m) C-C (MORE THAN 45MPH (70 km/h))

**MEDIANS OVER 4' (1.2 m) WIDE**

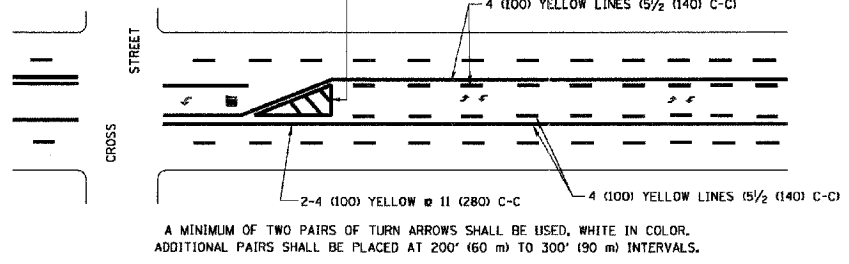

A MINIMUM OF TWO PAIRS OF TURN ARROWS SHALL BE USED, WHITE IN COLOR. ADDITIONAL PAIRS SHALL BE PLACED AT 200' (60 m) TO 300' (90 m) INTERVALS.

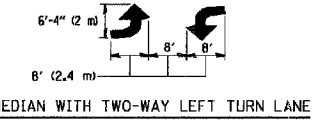

**TYPICAL PAINTED MEDIAN MARKING**

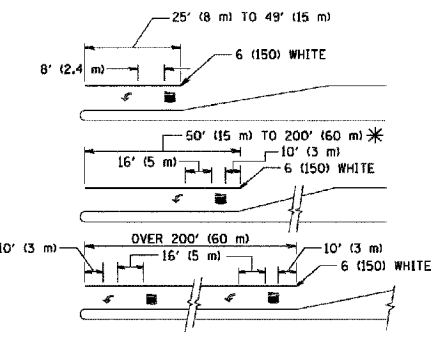

FULL SIZE LETTERS 8' (2.4 m) AND ARROWS SHALL BE USED.  
AREA = 15.6 SQ. FT. (1.5 m<sup>2</sup>) ONLY AREA = 20.8 SQ. FT. (1.9 m<sup>2</sup>)  
\* TURN LANES IN EXCESS OF 400' (120 m) IN LENGTH MAY HAVE AN ADDITIONAL SET OF ARROW - "ONLY" INSTALLED MIDWAY BETWEEN THE OTHER TWO SETS OF ARROW - "ONLY".

**TYPICAL TURN LANE MARKING**

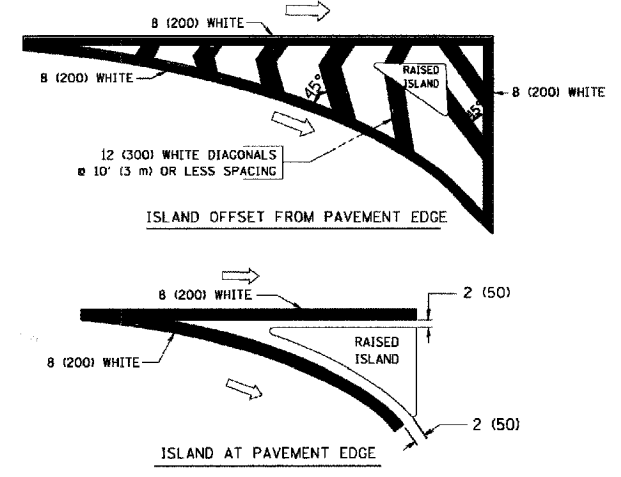

**TYPICAL ISLAND MARKING**

TYPE OF MARKING	WIDTH OF LINE	PATTERN	COLOR	SPACING / REMARKS
CENTERLINE ON 2 LANE PAVEMENT	4 (100)	SKIP-DASH	YELLOW	10' (3 m) LINE WITH 30' (9 m) SPACE
CENTERLINE ON MULTI-LANE UNDIVIDED PAVEMENT	2 @ 4 (100)	SOLID	YELLOW	11 (280) C-C
NO PASSING ZONE LINES: FOR ONE DIRECTION FOR BOTH DIRECTIONS	4 (100) 2 @ 4 (100)	SOLID SOLID	YELLOW YELLOW	5/2 (140) C-C FROM SKIP-DASH CENTERLINE 11 (280) C-C OMIT SKIP-DASH CENTERLINE BETWEEN
LANE LINES	4 (100) 5 (125) ON FREEWAYS	SKIP-DASH SKIP-DASH	WHITE WHITE	10' (3 m) LINE WITH 30' (9 m) SPACE
DOTTED LINES (EXTENSIONS OF CENTER, LANE OR TURN LANE MARKINGS)	SAME AS LINE BEING EXTENDED	SKIP-DASH	SAME AS LINE BEING EXTENDED	2' (600) LINE WITH 6' (1.8 m) SPACE
EDGE LINES	4 (100)	SOLID	YELLOW-LEFT WHITE-RIGHT	OUTLINE MOUNTABLE MEDIANS IN YELLOW; EDGE LINES ARE NOT USED NEXT TO BARRIER CURB
TURN LANE MARKINGS	6 (150) LINE; FULL SIZE LETTERS & SYMBOLS (8' (2.4m))	SOLID	WHITE	SEE TYPICAL TURN LANE MARKING DETAIL
TWO WAY LEFT TURN MARKING	2 @ 4 (100) EACH DIRECTION 8' (2.4m) LEFT ARROW	SKIP-DASH AND SOLID IN PAIRS	YELLOW WHITE	10' (3 m) LINE WITH 30' (9 m) SPACE FOR SKIP-DASH; 5/2 (140) C-C BETWEEN SOLID LINE AND SKIP-DASH LINE SEE TYPICAL TWO-WAY LEFT TURN MARKING DETAIL
CROSSWALK LINES (PEDESTRIAN) A. DIAGONALS (BIKE & EQUESTRIAN) B. LONGITUDINAL BARS (SCHOOL)	2 @ 6 (150) 12 (300) @ 45° 12 (300) @ 90°	SOLID SOLID SOLID	WHITE WHITE WHITE	NOT LESS THAN 6' (1.8 m) APART 2' (600) APART SEE TYPICAL CROSSWALK MARKING DETAILS.
STOP LINES	24 (600)	SOLID	WHITE	PLACE 4' (1.2 m) IN ADVANCE OF AND PARALLEL TO CROSSWALK, IF PRESENT. OTHERWISE, PLACE AT DESIRED STOPPING POINT. PARALLEL TO CROSSROAD CENTERLINE, WHERE POSSIBLE
PAINTED MEDIANS	2 @ 4 (100) WITH 12 (300) DIAGONALS @ 45° NO DIAGONALS USED FOR 4' (1.2 m) WIDE MEDIANS	SOLID	YELLOW: TWO WAY TRAFFIC WHITE: ONE WAY TRAFFIC	11 (280) C-C FOR THE DOUBLE LINE SEE TYPICAL PAINTED MEDIAN MARKING.
GORE MARKING AND CHANNELIZING LINES	8 (200) WITH 12 (300) DIAGONALS @ 45°	SOLID	WHITE	DIAGONALS: 15' (4.5 m) C-C (LESS THAN 30MPH (50 km/h)) 20' (6 m) C-C 30MPH (50 km/h) TO 45MPH (70 km/h) 30' (9 m) C-C (OVER 45MPH (70 km/h))
RAILROAD CROSSING	24 (600) TRANSVERSE LINES; "RR" IS 6' (1.8 m) LETTERS; 16 (400) LINE FOR "X"	SOLID	WHITE	SEE STATE STANDARD 780001 AREA OF: "R"=3.6 SQ. FT. (0.33 m <sup>2</sup> ) EACH "X"=54.0 SQ. FT. (5.0 m <sup>2</sup> )
SHOULDER DIAGONALS	12 (300) @ 45°	SOLID	WHITE - RIGHT YELLOW - LEFT	50' (15 m) C-C (LESS THAN 30MPH (50 km/h)) 75' (25 m) C-C (30 MPH (50 km/h) TO 45MPH (70 km/h)) 150' (45 m) C-C (OVER 45MPH (70 km/h))

FOR FURTHER DETAILS ON PAVEMENT MARKING REFER TO STANDARD SPECIFICATIONS FOR ROAD AND BRIDGE CONSTRUCTION AND STATE STANDARD 780001.

All dimensions are in inches (millimeters) unless otherwise shown.

REVISIONS	
NAME	DATE
EVERS	03-19-90
T. RAMMACHER	10-27-94
ALEX HOUSEH	10-09-96
ALEX HOUSEH	10-17-96
T. RAMMACHER	01-06-00

ILLINOIS DEPARTMENT OF TRANSPORTATION  
**DISTRICT ONE  
TYPICAL PAVEMENT  
MARKINGS**

SCALE: NONE  
DRAWN BY CADD  
CHECKED BY  
TC-13