

NOTES:

1. EACH CURRENT-CARRYING CABLE MAKING A CONNECTION IN THE LIGHT BASE SHALL HAVE A MINIMUM 4' SLACK LOOP COILED NEATLY INSIDE THE LIGHT BASE. (SLACK LOOP NOT REQUIRED FOR CABLE PASSING THROUGH LIGHT BASE WITHOUT CONNECTION).
2. THE UPPER CABLE ASSEMBLY SHALL BE TWO 14 AWG STRANDED THWN CABLES AND ELASTIMOLD WATERTIGHT PLUG CONNECTOR, STYLE 90P-58 FOR LIGHT BARS MOUNTED ON EMT SUPPORTS (EXCEPT THRESHOLD BAR), AT THE THRESHOLD BAR AND FOR STEADY-BURNING LAMPS MOUNTED ON LIR TOWERS. THE UPPER CABLE ASSEMBLY SHALL BE TWO 12 AWG STRANDED THWN CABLES AND ELASTIMOLD WATERTIGHT PLUG CONNECTOR, STYLE 90P-56.
3. THE LOWER CABLE ASSEMBLY SHALL BE TWO 10 AWG TYPE U.S.E. CABLES WITH ELASTIMOLD RECEPTACLE CONNECTOR, STYLE NO. 90R-86 AT LIGHT BARS MOUNTED ON EMT SUPPORTS (INCLUDING THE THRESHOLD BAR). FOR STEADY-BURNING LIGHT BARS MOUNTED ON LIR TOWERS, THE LOWER CABLE ASSEMBLY SHALL BE TWO 8 AWG TYPE U.S.E. CABLES WITH ELASTIMOLD RECEPTACLE CONNECTOR, STYLE NO. 90R-C4.
4. CONNECTIONS OF 10 AWG CABLES TO 2 AWG CABLES ARE MADE WITH BURNDY CAT. NO. YPC2ABU STREET LIGHTING TAPS. CONNECTIONS OF 2 AWG CABLES TO 1/0 AWG CABLES, IN FEED-THROUGH SPLICES ONLY, ARE MADE WITH BURNDY CAT. NO. YC26C2 COPPER CRIMPITS. SPLICE BODIES ARE MADE WITH 3M SCOTCHCAST MULTI-MOLD SPLICING KITS, 3M NO. 85-16.
5. ALL CONNECTIONS TO GROUNDING RODS SHALL BE MADE USING EXOTHERMIC WELDS PER SPECIFICATIONS.
6. ALL THREADS ON BOLTS SHALL BE COATED WITH ANTI-SEIZE COMPOUND.
7. A SILICONE RUBBER INSULATOR DISK (GFM) SHALL BE SECURELY INSTALLED BETWEEN THE LAMPHOLDER AND THE PAR-56 LAMP (THRESHOLD BAR ONLY).
8. EACH GREEN GLASS FILTER (THRESHOLD BAR ONLY) IS SECURED WITH THREE STAINLESS STEEL FILTER CLIPS, THE CONTRACTOR SHALL BEND THE FILTER CLIPS SUCH THAT THEY HOLD THE FILTER SECURELY WHEN THEY ARE BOLTED.
9. THE CONTRACTOR SHALL FURNISH AND INSTALL AN NBP PAR-56 LAMPHOLDER RING ON EACH PAR-56 LAMPHOLDER (THRESHOLD BAR ONLY). THIS RING FITS OVER THE LAMP-RETAINING CLIPS, AND HOLDS THE LAMP POSITIVELY IN PLACE. THE RING COMES WITH AN ATTACHED CHAIN HAVING A SS BOLT AT THE FREE END. REPLACE THE LAMPHOLDER'S EXISTING STAINLESS STEEL GROUNDING BOLT WITH THE CHAIN'S BOLT.
10. WHEN INSTALLING PAR-38 LAMPHOLDER, FEED PIGTAIL ENDS OF CABLE INTO LAMPHOLDER AND CONNECT TO TERMINALS IN LAMPHOLDER SOCKET. USE CARE TO PREVENT THE SOCKET RETENTION BOLTS FROM DAMAGING CABLE INSULATION.
11. SEE PLAN AND PROFILE DRAWING FOR LAMP CENTERLINE ELEVATION TO DETERMINE LENGTH OF 2' EMT REQUIRED AT EACH EMT LIGHT BAR. AT THE THRESHOLD BAR, THE CONDUIT SHALL BE SIZED SO THAT THE BOTTOM OF THE PAR-56 LAMPHOLDER BASE IS IN CONTACT WITH THE TOP OF THE FRANGIBLE COUPLING. THE LAMP CENTERLINE ELEVATION SHALL FOLLOW THE CROWN ELEVATION AT THE THRESHOLD BAR.

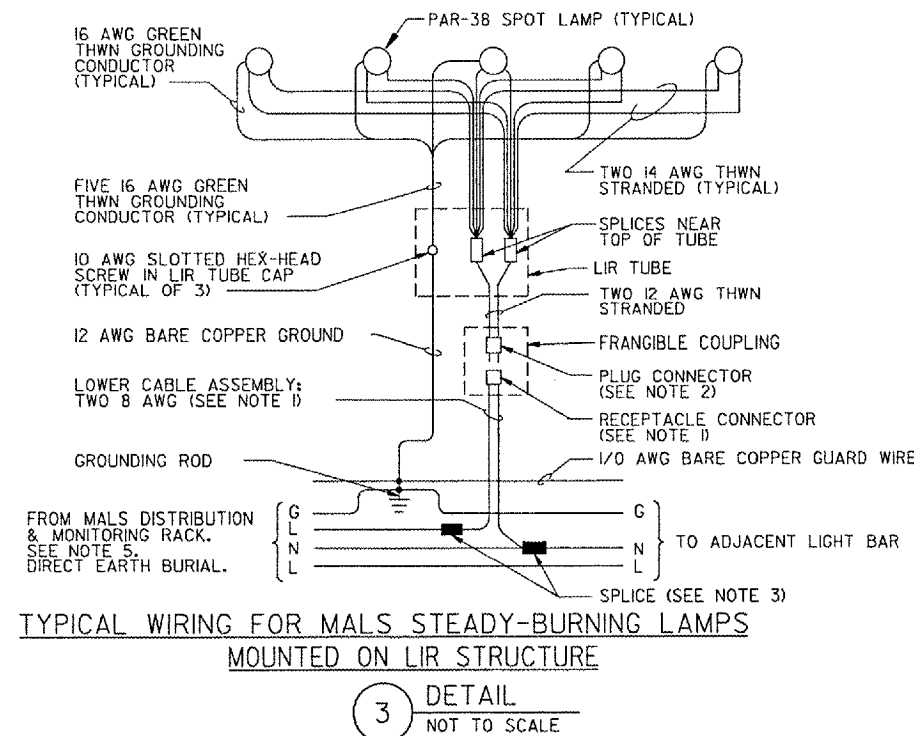
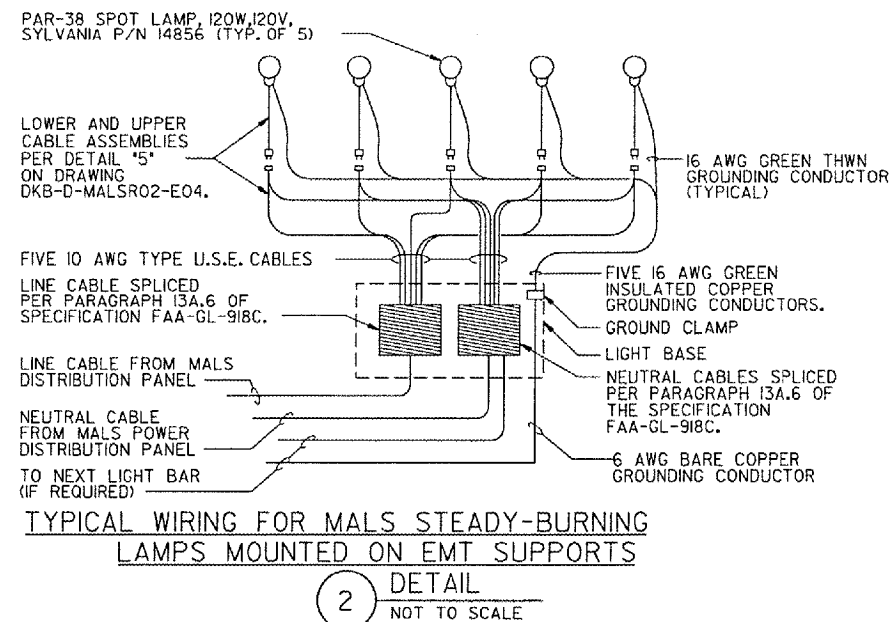

PLOT DATE = 03/26/2007 04:04 PM  
 FILE NAME = I:\a\m\DEKALB\BFB-98ELEC\Air-port\Sheets\Micro-Station Sheets\WIRING DIAGRAMS FOR STEADY-BURNING LT BARS.dgn  
 PLOT SCALE = 2.868 1/16"  
 USER NAME = kdb

DEPARTMENT OF TRANSPORTATION FEDERAL AVIATION ADMINISTRATION GREAT LAKES REGION CHICAGO, ILLINOIS			
MALS WIRING DIAGRAMS FOR STEADY-BURNING LIGHT BARS RUNWAY 02			
DEKALB		DEKALB TAYLOR MUNICIPAL AIRPORT	
REVIEWED BY	SUBMITTED BY	APPROVED BY	
PROJ. ENGR.		PLATFORM MGR.	
DATE	TAD	DATE	JCN
DRAWN	TAD	CHICAGO HAS IMPLEMENTATION CENTER	
DRAWN	EGS	DRAWING NO.	REV
		DKB-D-MALSRO2-E03	

DATE	DESCRIPTION	JCN	REV	DATE	APPROVED