

DETAIL - "A"
3 CABLE LOWERING & SUPPORT MECHANISM SHOWN.

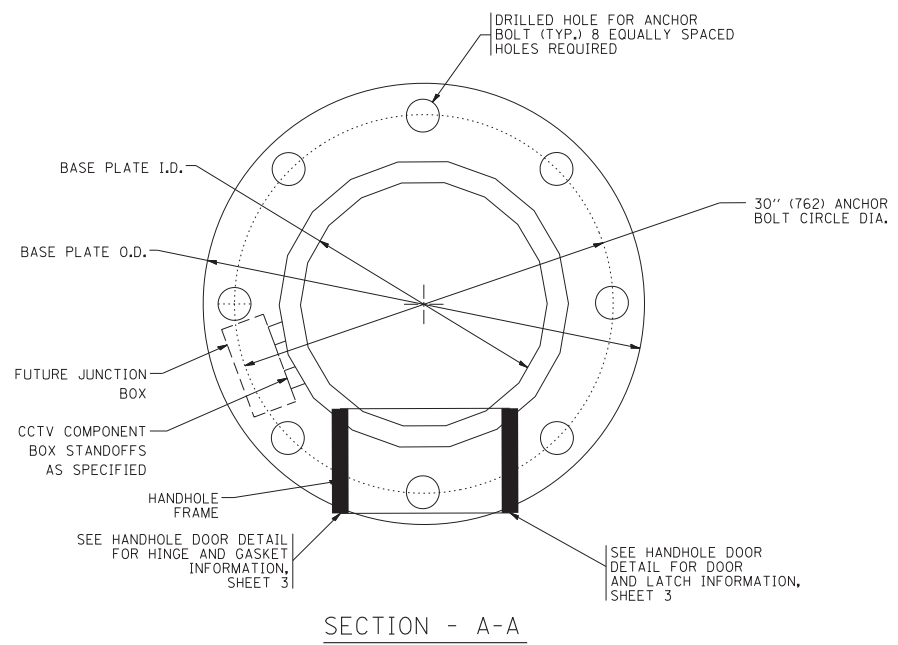

SECTION - A-A

- NOTES:**
- ALL DIMENSIONS ARE IN INCHES (MILLIMETERS) UNLESS OTHERWISE SHOWN.
 - THE DESIGN SHALL BE BASED UPON AASHTO "STANDARD SPECIFICATIONS FOR STRUCTURAL SUPPORTS FOR HIGHWAY SIGNS, LUMINAIRES AND TRAFFIC SIGNALS" CURRENT AT THE TIME THE PROJECT IS ADVERTISED AND A TOTAL COMBINED LUMINAIRE WEIGHT OF 720 LBS. (326 kg) AND HAVING A TOTAL PROJECTED AREA OF 24 SQ. FT. (7.3 sq. m).
 - ALL TOWER SHAFT COMPONENTS, INCLUDING, BUT NOT LIMITED TO THE SHAFT SECTIONS, BASE PLATE, LADDER CLIPS, HANDHOLE DOOR, HANDHOLE REINFORCING, RAIN GUTTER, AND BASE PLATE, SHALL BE FABRICATED FROM HIGH-STRENGTH, LOW ALLOY, STEEL WITH A MINIMUM YIELD STRENGTH OF 50,000 PSI (345 K PA) ACCORDING TO AASHTO M 223 (ASTM A 572 GR50)
 - THE ELECTRIC MOTOR, MOTOR GEAR REDUCER, WINCH DRUM ASSEMBLY AND AUTOMATIC SHUTOFF SWITCH OF THE LOWERING DEVICE SHALL BE ACCESSIBLE FROM THE FRONT OF THE TOWER FOR EASY REMOVAL AND MAINTENANCE. ALL COMPONENTS SHALL BE REMOVABLE THROUGH THE HANDHOLE.
 - THE LIGHT TOWER SHAFT SHALL HAVE LADDER CLIPS. CLIPS SHALL BEGIN 6 FT. (1.8 m) ABOVE THE BASE PLATE WITH ALTERNATE 36 INCH (900) AND 10 INCH (250) SPACING THEREAFTER, FOR THE ENTIRE LENGTH. THE TOP 10 FT. (3 m) OF THE POLE SHAFT SHALL HAVE 3 SETS OF CLIPS. EACH SET OF CLIPS SHALL BE 120 DEGREES APART. CLIPS SHALL BE 0.25 X 2 INCHES (6 X 50) WELDED TO THE SHAFT TO PRODUCE A SLOT 0.625 INCHES (15.9) DEEP AND 1.625 INCHES (41.3) LONG. THE TOP INSIDE EDGE SHALL BE CHAMFERED.
 - A COPPER BONDING JUMPER SHALL BOND SLIP-FIT POLE SECTIONS TOGETHER WITH A FLAT COPPER MESH AND STAINLESS STEEL GROUND LUGS.
 - ALL TOWER SHAFT HARDWARE, SUCH AS GROUND LUGS, JUNCTION BOXES, HARDWARE FOR THE HANDHOLE DOOR, INCLUDING THE HANDLE/LATCH MECHANISM, HINGE AND DOOR STOP, SHALL BE STAINLESS STEEL. ALL CONDUIT AND CONDUIT FITTINGS SHALL BE PVC COATED GALVANIZED STEEL.
 - THE ENTIRE TOWER INCLUDING THE SHAFT, HANDHOLE, HANDHOLE DOOR, BASE PLATE AND ALL OTHER ELEMENTS WELDED TO THE SHAFT SHALL BE GALVANIZED IN ACCORDANCE WITH AASHTO M 111 (ASTM A 123) AND THEN PAINTED AS SPECIFIED. THE LUMINAIRE RING SHALL BE PRIMED AND PAINTED AS SPECIFIED.
 - THE FINISH COAT SHALL BE ANSI 70, SKY GREY COLOR SAMPLE TO BE SUBMITTED FOR APPROVAL. ON LIGHT TOWERS DESIGNED FOR A CCTV CAMERA TO BE INSTALLED, THE TOP SECTION OR 30 FT. WHICH EVER IS GREATER OF THE TOWER SHAFT SHALL BE PAINTED FLAT BLACK. OTHER SECTIONS SHALL BE ANSI 70, SKY GREY.
 - ALL MULTI-CONDUCTOR CABLES SHALL BE FITTED WITH A HEAT-SHRINK MULTI-LEG BOOT. THE BOOT SHALL MEET MILITARY SPECIFICATION MIL-I-81765/1.
 - THE LIGHT TOWER SHALL BE STRAIGHT AND CENTERED ON ITS LONGITUDINAL AXIS, UNDER NO-WIND CONDITIONS, SO WHEN EXAMINED FROM ANY DIRECTION, THE DEVIATION FROM THE NORMAL SHALL NOT EXCEED 1/8 IN. IN 3 FT (2 mm IN 1 m) WITHIN ANY 5 FT (1.5 m) OF HEIGHT, WITH TOTAL DEVIATION NOT TO EXCEED 3 IN. (75) FROM THE VERTICAL AXIS THROUGH THE CENTER OF THE POLE BASE.
 - PVC CONDUIT WILL NOT BE ALLOWED FOR ANY LIGHT TOWER COMPONENT.
 - COUNTER WEIGHTS TO BE INCLUDED AS A PART OF THE LIGHT TOWER PAY ITEM.

| | | | | | | | | | | | | |
|---|-------------------|-------------------------------|--|---|---|------|---------|---------------|---------|--------------|--------------|-----------|
| FILE NAME = W:\diststd\22x34\be500.dgn | USER NAME = leuso | DESIGNED - DRAWN - | REVISED - R. TOMSONS 08-04-03 REVISED - R. TOMSONS 05-11-09 | STATE OF ILLINOIS DEPARTMENT OF TRANSPORTATION | HIGH MAST LIGHT TOWER 90 FT TO 110 FT (27 m TO 34 m) | | | F.A. RTE. | SECTION | COUNTY | TOTAL SHEETS | SHEET NO. |
| PLOT SCALE = 50.0000 ' / IN. | CHECKED - | REVISED - R. TOMSONS 09-02-10 | SCALE: NONE | | SHEET NO. 1 OF 3 SHEETS | STA. | TO STA. | BE-500 | | CONTRACT NO. | 507 | 214 |
| PLOT DATE = 11/22/2010 | DATE - | REVISED - | FED. ROAD DIST. NO. 1 ILLINOIS FED. AID PROJECT | | | | | | | | | |