

NOTE: PIPE AUXILIARY DRAINS (IF ANY) WITH CLEANABLE P-TRAP.

3 CONDENSATE DRAIN PIPING DETAIL
N.T.S.

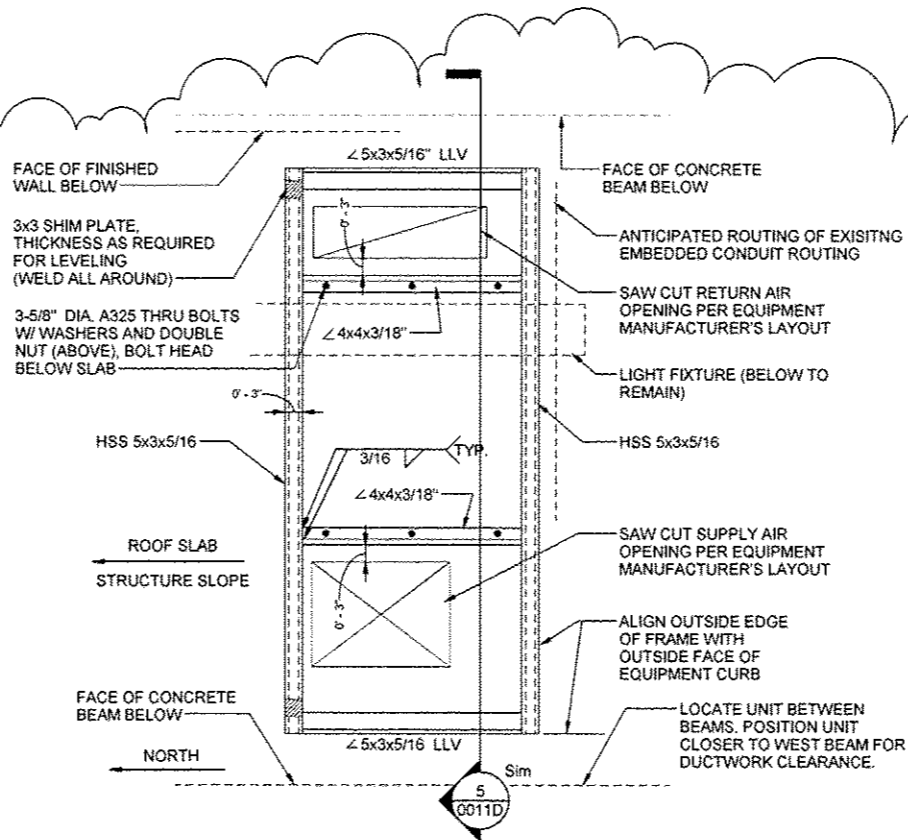

4 RTU STRUCTURAL SUPPORT PLAN
N.T.S. (INCLUDED WITH MECHANICAL WORK, COMPLETE)

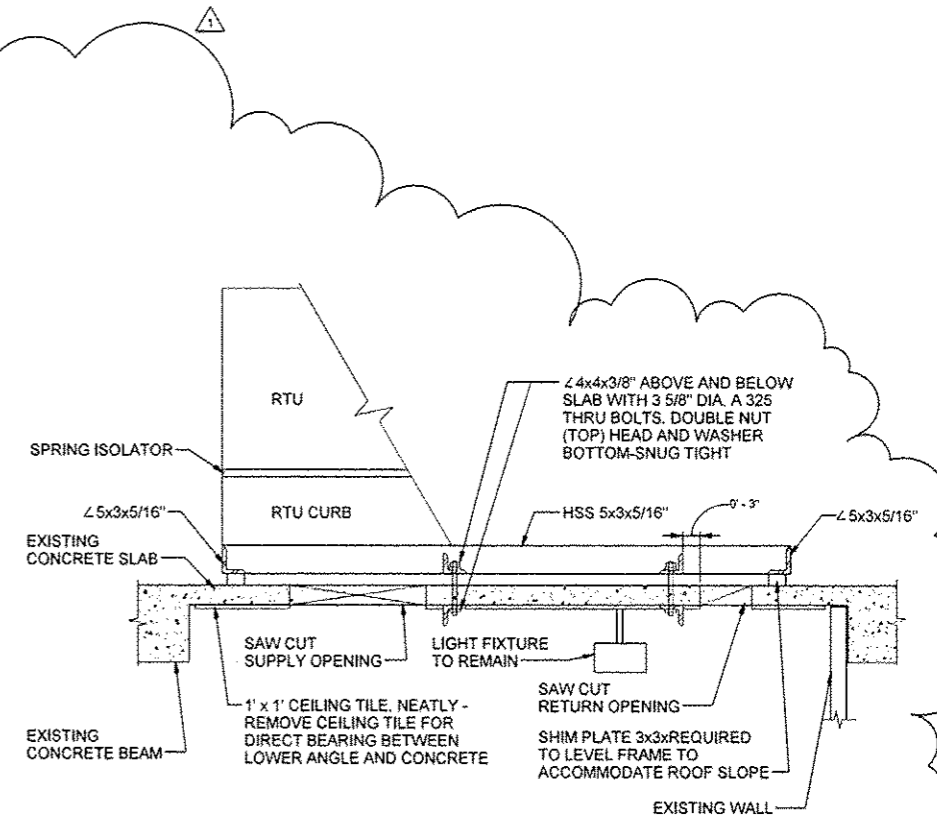

5 RTU STRUCTURAL SUPPORT SECTION
N.T.S.

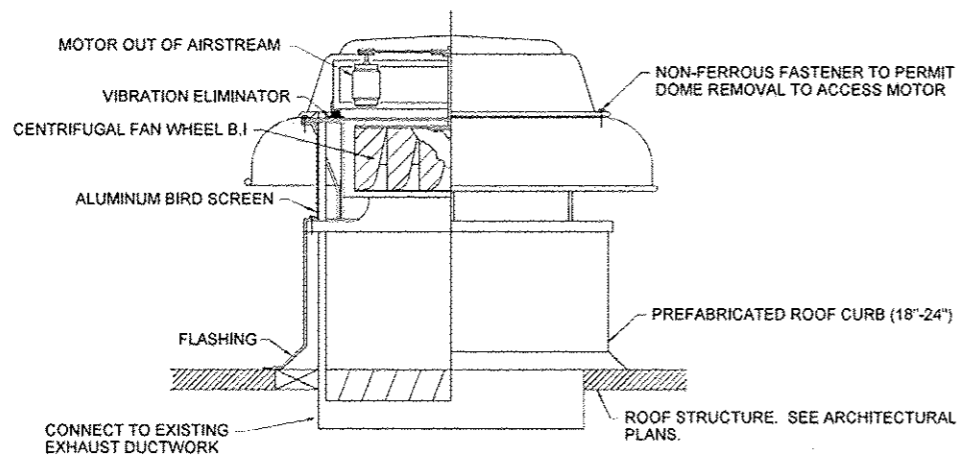

1 ROOF MOUNTED EXHAUST FAN
N.T.S.

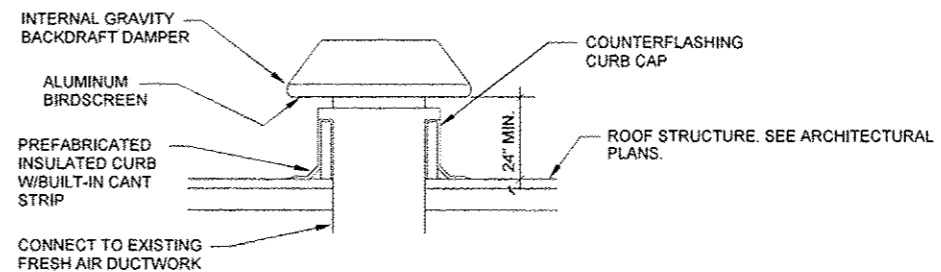

2 ROOF MOUNTED INTAKE VENTILATOR DETAIL
N.T.S.



USER NAME =	DESIGNED - JPD/ATK	REVISED - 09/04/12 NEWLY ADDED SHEET
PLOT SCALE =	DRAWN - HWH	REVISED
PLOT DATE =	CHECKED - JPD	REVISED
	APPROVED - ATK	REVISED

STATE OF ILLINOIS
DEPARTMENT OF
TRANSPORTATION

MECHANICAL DETAILS

Scale SHEET NO. 11 OF 11 SHEETS Station From Station To

F.A.P. RTE.	SECTION	COUNTY	TOTAL SHEETS	SHEET NO.
	2012-0451	WILL	11	0011D
CONTRACT NO. 60V37				
ILLINOIS FED. AID PROJECT				