

WEST ABUTMENT BILL OF MATERIAL

Bar	No.	Size	Length	Shape
h80(E)	42	#5	22'-3"	—
h81(E)	84	#5	24'-3"	—
h82(E)	16	#5	10'-4"	└
h83(E)	16	#5	10'-4"	└
h84(E)	30	#6	25'-3"	—
h85(E)	10	#6	27'-3"	—
h86(E)	24	#4	17'-8"	—
h87(E)	10	#4	16'-7"	—
h88(E)	2	#4	16'-4"	—
h89(E)	10	#4	18'-11"	—
h90(E)	2	#4	19'-0"	—
n80(E)	31	#6	13'-4"	—
n81(E)	12	#6	6'-8"	—
p80(E)	20	#7	32'-9"	—
p81(E)	40	#7	35'-9"	—
p82(E)	6	#7	17'-10"	—
p83(E)	6	#7	19'-6"	—
p84(E)	8	#5	19'-5"	—
p85(E)	12	#5	23'-6"	—
p86(E)	4	#5	4'-6"	—
p87(E)	12	#5	20'-4"	—
p88(E)	4	#5	8'-3"	—
s80(E)	325	#4	15'-11"	□
s81(E)	55	#4	9'-5"	□
s82(E)	2	#4	21'-3"	□
s83(E)	170	#5	8'-5"	□
s84(E)	2	#5	11'-1"	□
u80(E)	20	#6	12'-1"	—
u81(E)	4	#6	10'-10"	—
u82(E)	5	#6	14'-9"	—
v80(E)	121	#5	3'-9"	└
v81(E)	189	#4	3'-0"	└
v82(E)	38	#6	9'-10"	—
v83(E)	6	#6	9'-10"	—
v84(E)	31	#6	10'-0"	—
v85(E)	189	#5	8'-9"	—
v86(E)	189	#5	7'-5"	—
Structure Excavation	Cu. Yd.		874	
Concrete Structures	Cu. Yd.		234.5	
Reinforcement Bars, Epoxy Coated	Pound		22,830	
Furnishing Metal Shell Piles 12" x 0.250"	Foot		2,720	
Driving Piles	Foot		2,720	
Test Pile Metal Shells	Each		1	
Concrete Sealer	Sq. Ft.		1,738	

Bars indicated thus 10x2 - #7 etc. indicates 10 lines of bars with 2 lengths per line.

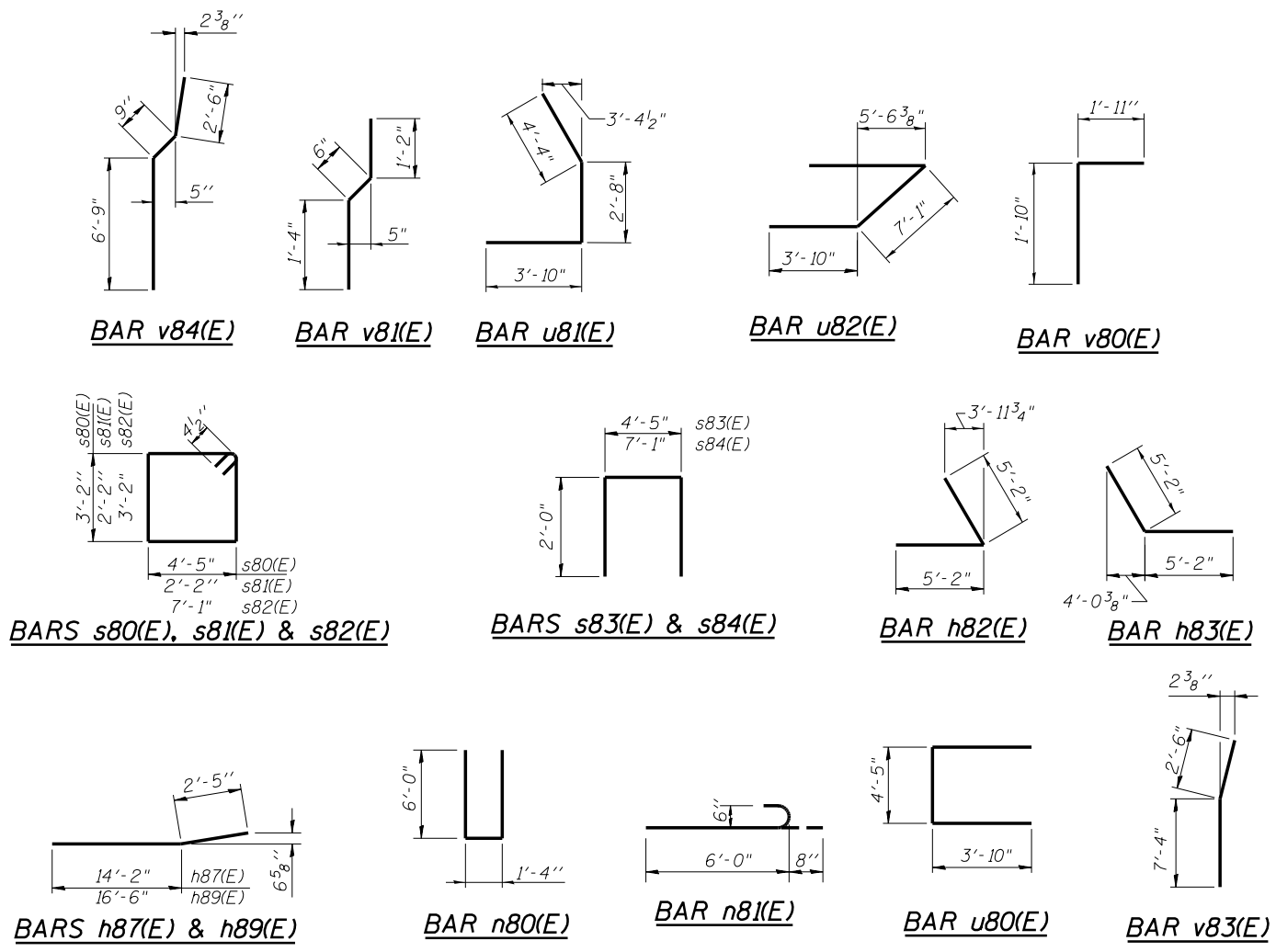

- NOTES:**
- Quantity of concrete in end post included with Concrete Superstructure on sheet SB17.
 - For details of Bar Splicers, see sheet SB53.
 - Quantity of concrete in hatch block included with Concrete Superstructure on sheet SB17.
 - For details of piles, see sheet SB52.

FILE NAME =	USER NAME = mbecker	DESIGNED - DTS	REVISED -
0900167.68620.37.wabut7.dgn		CHECKED - SLD	REVISED -
	PLOT SCALE =	DRAWN - PRT/DTS	REVISED -
	PLOT DATE = 7/16/2012	CHECKED - SLD	REVISED -

**STATE OF ILLINOIS
DEPARTMENT OF TRANSPORTATION**

**WEST ABUTMENT DETAILS 2 OF 2
STRUCTURE NO. 090-0167**

F.A.I. RTE.	SECTION	COUNTY	TOTAL SHEETS	SHEET NO.
74	90-[14R;14HB-4;14,14HVB]BR	TAZEWELL	2433	1948
CONTRACT NO. 68620			ILLINOIS FED. AID PROJECT	

x:\10000s\10056\engineer-ing-documents-phase-1\174over-Jefferson\Final\0900167.68620.37.wabut7.dgn 11:08:46 AM 7/16/2012