

DRAIN DETAIL

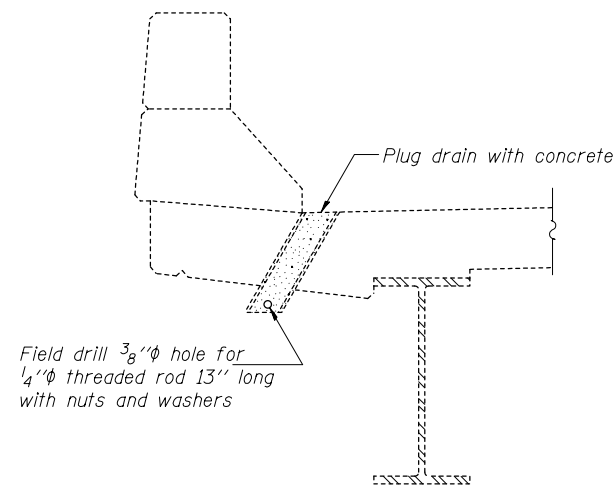

PLUG DRAIN DETAIL

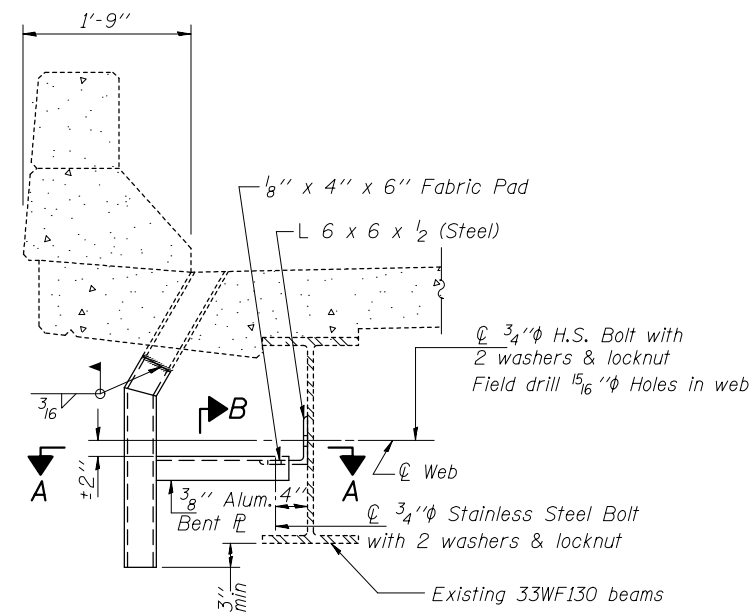

SECTION AT DRAIN

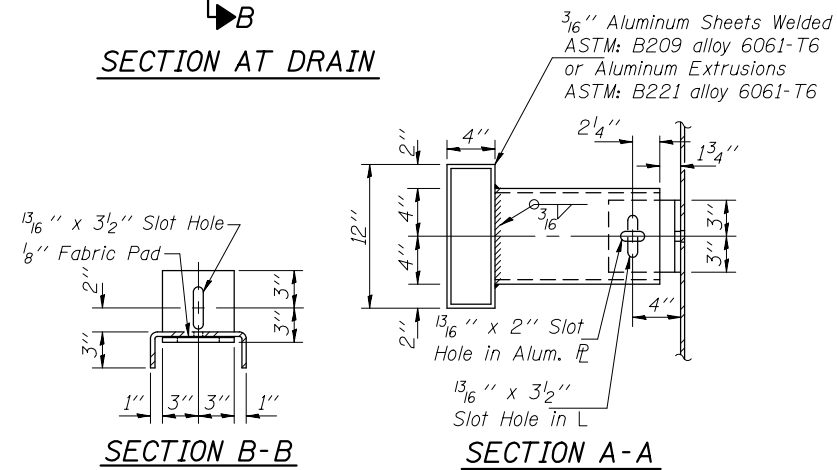

SECTION B-B

SECTION A-A

DESIGNED - A.Y.V.	EXAMINED	DATE -
CHECKED -	ENGINEER OF STRUCTURAL SERVICES	
DRAWN - A.Y.V.	PASSED	REVISED
CHECKED -	ENGINEER OF BRIDGES AND STRUCTURES	REVISED

**STATE OF ILLINOIS
DEPARTMENT OF TRANSPORTATION**

**DRAIN DETAILS
SN 060-0160**

SHEET NO. 10 OF 13 SHEETS

RTE.	SECTION	COUNTY	TOTAL SHEETS	SHEET NO.
CH 1	1-HB-1	MADISON	28	24
			CONTRACT NO. 76F62	
ILLINOIS FED. AID PROJECT				