

STATE OF ILLINOIS
DEPARTMENT OF TRANSPORTATION

ROUTE NO.	SECTION	COUNTY	TOTAL SHEETS	SHEET NO.	SHEET NO. 12
FAJ-55	**	WILL	505	353	32 SHEETS
FED. ROAD DIST. NO. 7	ILLINOIS	FED. AID PROJECT			

** SECTION 2006-032 BY
CONTRACT NO. 60B86

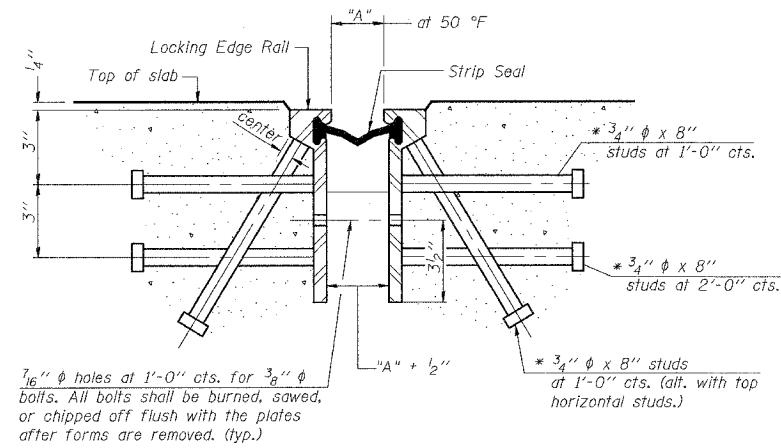

Required Strip Seal rated movement	"A"
1"	1 1/8"
2"	1 3/4"

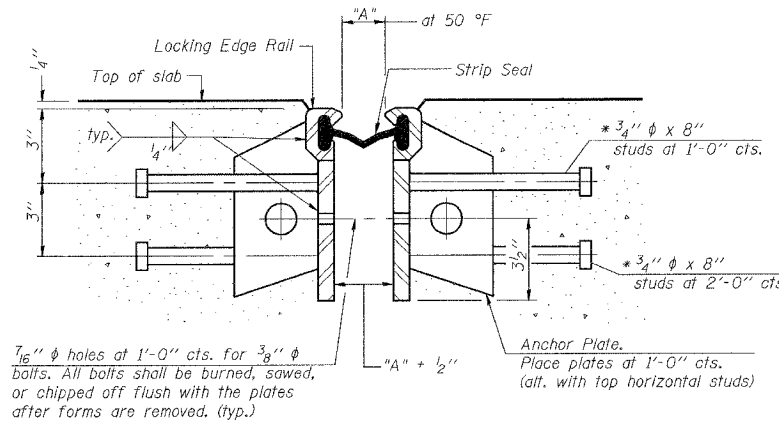

GENERAL NOTES

1. The strip seal shall be made continuous and shall have a minimum thickness of 1/4". The configuration of the strip seal shall match the configuration of the Locking Edge Rails.
2. The height and thickness of the Locking Edge Rails shown are minimum dimensions. The actual configuration of the Locking Edge Rails and matching strip seal may vary from manufacturer to manufacturer. Flanged edge rails will not be allowed.
3. Locking Edge Rails may be spliced at slope discontinuities and stage construction joints.
4. The manufacturer's recommended installation methods shall be followed.
5. The joint opening and deck dimensions detailed on the superstructure are based on a preformed joint seal. If the contractor elects to use the alternate strip seal joint, the opening and deck dimensions shall be modified according to the dimensions detailed on this sheet. Required modifications shall be made at no additional cost to the State.

SECTION THRU ROLLED RAIL EXP. JOINT

(324 Studs Required For SB Bridge)
(324 Studs Required For NB Bridge)

* Granular or solid flux filled headed studs conforming to Article 1006.32 of the Std. Specs., automatically end welded.

SECTION THRU WELDED RAIL EXP. JOINT

(216 Studs & 108 Anchor Plates Required for SB Bridge)
(216 Studs & 108 Anchor Plates Required for NB Bridge)

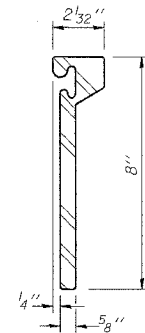

ROLLED (EXTRUDED) RAIL

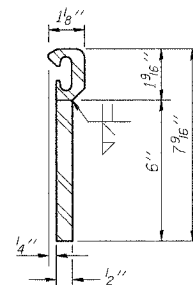

WELDED RAIL

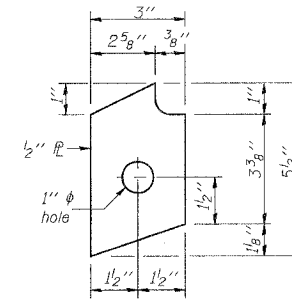

ANCHOR PL
(for welded rail)

LOCKING EDGE RAILS

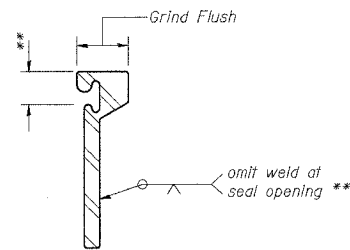

LOCKING EDGE RAIL SPLICE

The inside of the locking edge rail groove shall be free of weld residue.

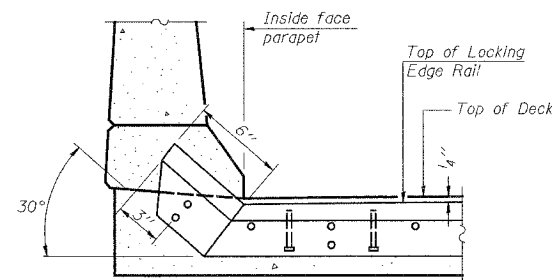

AT PARAPETS

DESIGNED	S.CHELBIAN
CHECKED	J.GRAINAWI
DRAWN	S.CHELBIAN
CHECKED	J.GRAINAWI

Date: 6/30/2006

(Sheet 2 of 2)
**BRIDGE JOINT SYSTEM-EXPANSION
(ALTERNATE STRIP SEAL)
I-55 OVER MS (ABANDONED) R.R.
FAI ROUTE 55-SEC. 2006-032 BY
WILL COUNTY
STA. 710+34.86
STRUCTURE NO. 099-0022 (NB)
STRUCTURE NO. 099-0023 (SB)**

