

Doweled contraction joint (typ.)  
(Placed in prolongation with pavement joints)  
construction option:  
1. Form with 3 (3/8) thick steel template  
50 (2) deep, and seal.  
2. Saw at 4 to 24 hours, and seal.

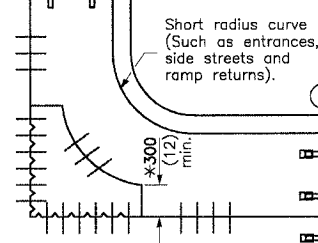

Pavement expansion joint with (or without) dowels

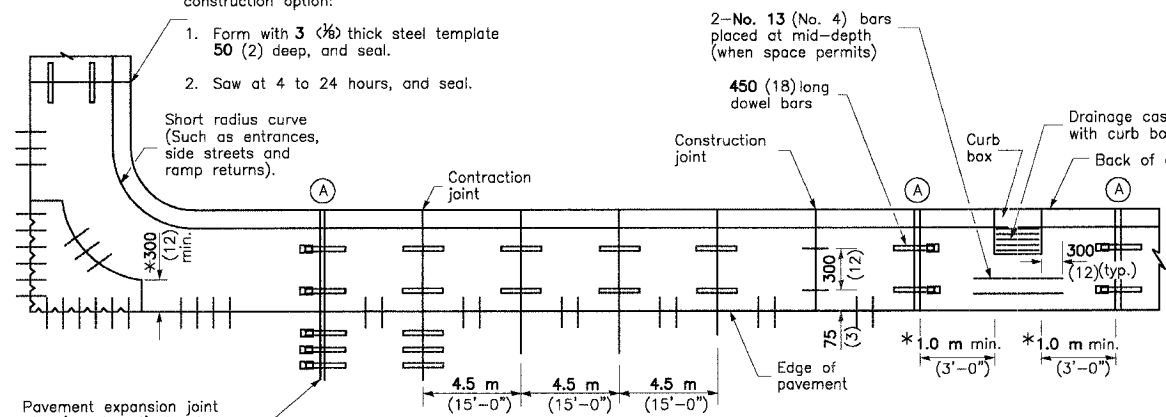

PLAN

ADJACENT TO PCC PAVEMENT OR PCC BASE COURSE

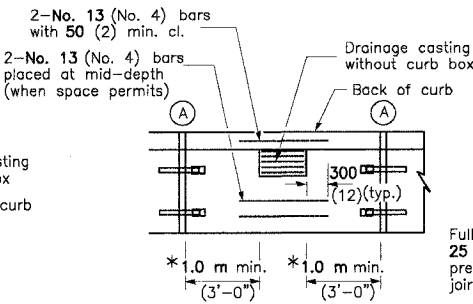

\* This dimension shall be adjusted to align with joint on the adjacent pavement

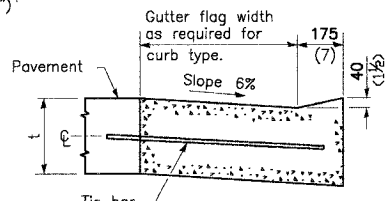

DEPRESSED CURB (TYPICAL)

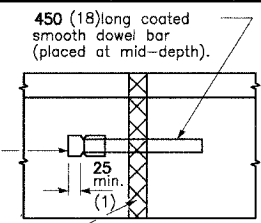

DETAIL A  
EXPANSION JOINT

Full depth & width 25 (1) - thick (min.)  
preformed expansion joint filler.

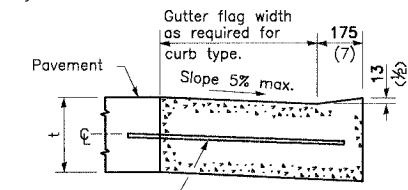

DEPRESSED CURB ADJACENT TO CURB RAMP ACCESSIBLE TO THE DISABLED

GENERAL NOTES

The bottom slope of combination curb and gutter constructed adjacent to pcc pavement shall be the same slope as the subbase or 6% when subbase is omitted.

t = Thickness of pavement.

Longitudinal joint tie bars shall be No. 20 (No. 6) at 600 mm (24") centers in accordance with details for longitudinal construction joint shown on Standard 420001.

A minimum clearance of 50 mm (2") between the end of the tie bar and the back of the curb shall be maintained.

All dimensions are in millimeters (inches) unless otherwise shown.

CONCRETE CURB TYPE B AND COMBINATION CONCRETE CURB AND GUTTER

(Sheet 1 of 2)

STANDARD 606001-02

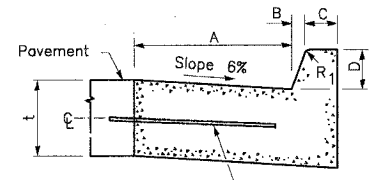

BARRIER CURB

TABLE OF DIMENSIONS BARRIER CURB					
TYPE	A	B	C	D	R <sub>1</sub>
B-15.30 (B-6.12)	300 (12)	25 (1)	150 (6)	150 (6)	25 (1)
B-15.45 (B-6.18)	450 (18)	25 (1)	150 (6)	150 (6)	25 (1)
B-15.60 (B-6.24)	600 (24)	25 (1)	150 (6)	150 (6)	25 (1)
B-22.30 (B-9.12)	300 (12)	50 (2)	125 (5)	225 (9)	25 (1)
B-22.45 (B-9.18)	450 (18)	50 (2)	125 (5)	225 (9)	25 (1)
B-22.60 (B-9.24)	600 (24)	50 (2)	125 (5)	225 (9)	25 (1)

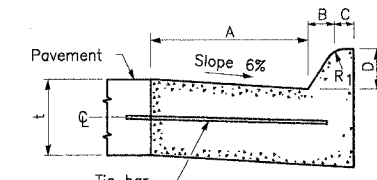

MOUNTABLE CURB

TABLE OF DIMENSIONS MOUNTABLE CURB						
TYPE	A	B	C	D	R <sub>1</sub>	R <sub>2</sub>
M-5.15 (M-2.06)	150 (6)	50 (2)	100 (4)	50 (2)	75 (3)	50 (2)
M-5.30 (M-2.12)	300 (12)	50 (2)	100 (4)	50 (2)	75 (3)	50 (2)
M-10.15 (M-4.06)	150 (6)	100 (4)	75 (3)	100 (4)	75 (3)	NA
M-10.30 (M-4.12)	300 (12)	100 (4)	75 (3)	100 (4)	75 (3)	NA
M-10.45 (M-4.18)	450 (18)	100 (4)	75 (3)	100 (4)	75 (3)	NA
M-10.60 (M-4.24)	600 (24)	100 (4)	75 (3)	100 (4)	75 (3)	NA
M-15.15 (M-6.06)	150 (6)	150 (6)	50 (2)	150 (6)	50 (2)	NA
M-15.30 (M-6.12)	300 (12)	150 (6)	50 (2)	150 (6)	50 (2)	NA
M-15.45 (M-6.18)	450 (18)	150 (6)	50 (2)	150 (6)	50 (2)	NA
M-15.60 (M-6.24)	600 (24)	150 (6)	50 (2)	150 (6)	50 (2)	NA

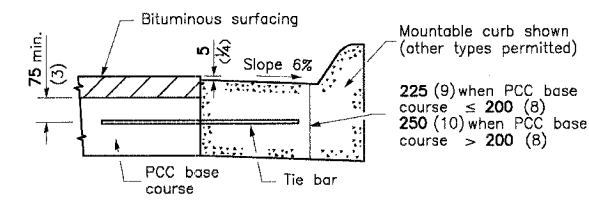

ADJACENT TO PCC BASE COURSE AND BITUMINOUS SURFACING

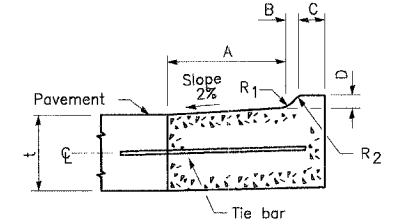

M-5.15 (M-2.06) and M-5.30 (M-2.12)

**MORRIS ENGINEERING, INC.**  
5100 S. LINCOLN • SUITE 100 • LISLE, ILLINOIS 60532  
PHONE: (630)271-0770 • EMAIL: ECIVIL.COM  
DWG LOCATION: H\04-PH\3004\PLANS-ENG\REV-1  
DRAWN BY: CJS/CMM FLD. BK. / PG. NO.: . . .  
COMPLETION DATE: 4/26/06 JOB NO.: 04-PH-3004

**HARLEM AVENUE MEDIAN IMPROVEMENTS**

**DETAIL SHEET**

DATE	REVISIONS	BY	SHEET
1 6/1/06	PER IDOT 5/18/06	OSC	<b>15</b> OF 31 SHEETS
2			
3			