

CONTRACT NO. 95480

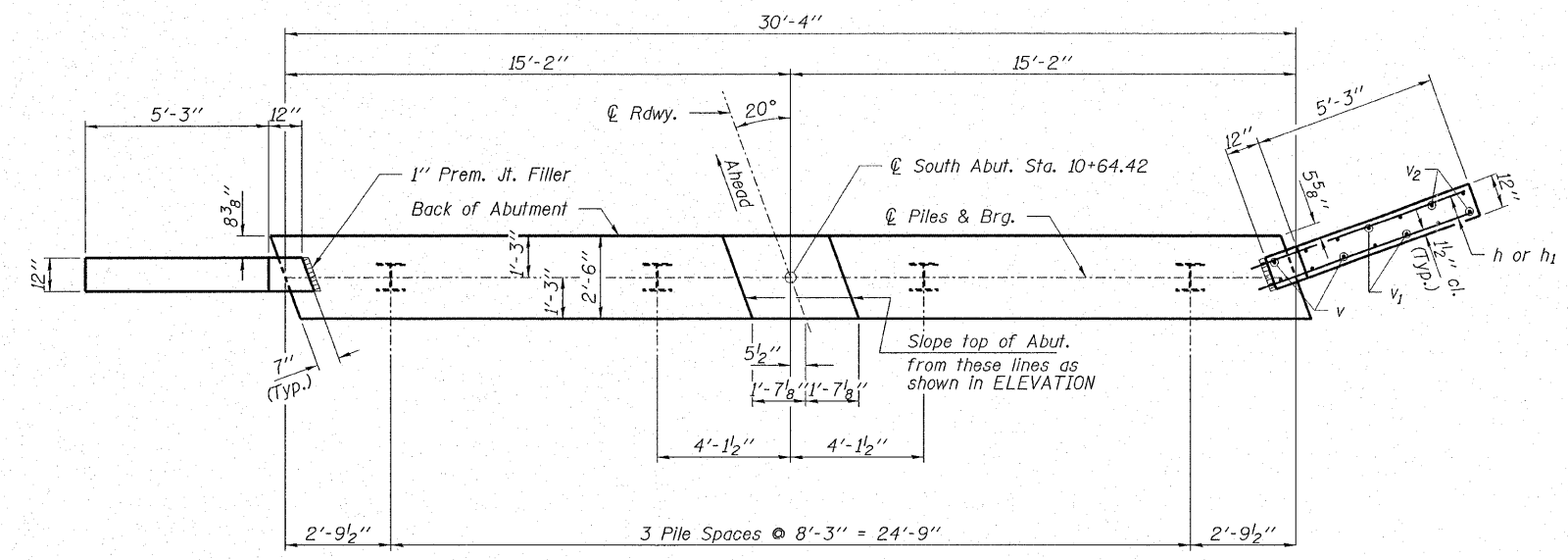

**PLAN**

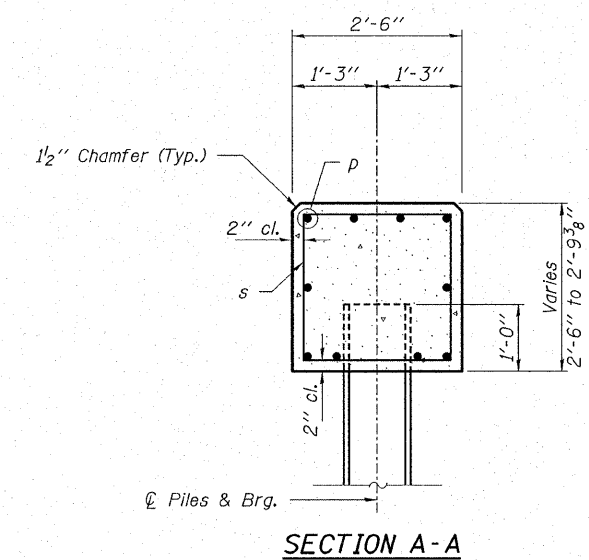

**SECTION A-A**

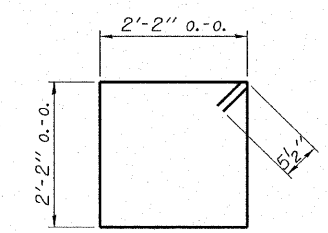

**BAR s**

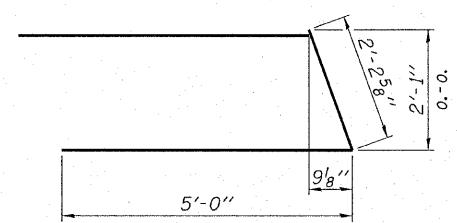

**BAR u**

Note: Extend h bars into abut. cap.

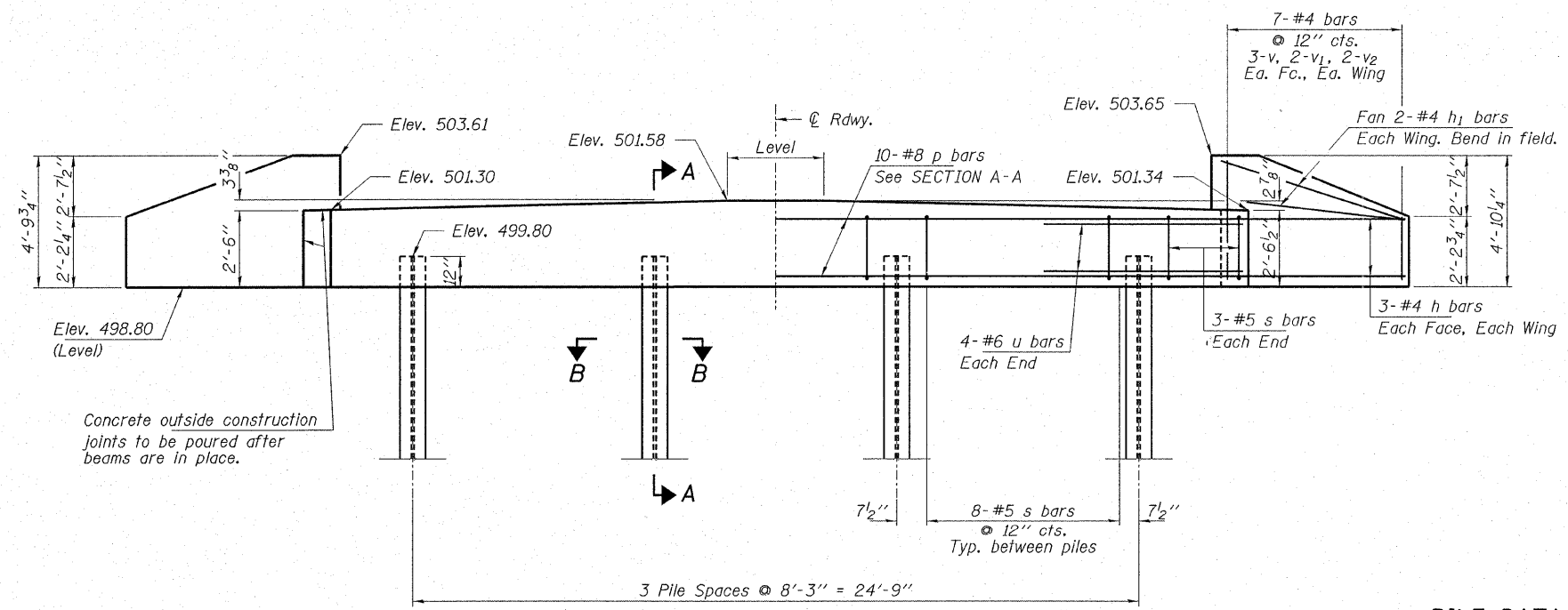

**ELEVATION**  
(Looking North)

**PILE DATA**

Type.....Steel HP10x42  
 No. Req'd.....4\*  
 Capacity.....Drive To Refusal  
 Est. Length.....20 Feet/Pile

\* Includes one steel test pile to be driven in a permanent location at the North Abutment.

**BILL OF MATERIAL - N. ABUT.**

BAR	NO.	SIZE	LENGTH	SHAPE
h	12	#4	7'-0"	—
h <sub>1</sub>	8	#4	6'-0"	—
p	10	#8	30'-0"	—
s	30	#5	9'-7"	□
u	8	#6	12'-3"	U
v	12	#4	4'-0"	—
v <sub>1</sub>	8	#4	3'-0"	—
v <sub>2</sub>	8	#4	2'-0"	—
Concrete Structures		Cu. Yd.	9.1	
Reinforcement Bars		Pound	1,400	
Furnishing Steel Piles HP10x42		Foot	60	
Driving Steel Piles		Foot	60	
Test Pile Steel HP10x42		Each	1	

**HAMPTON, LENZINI & RENWICK, INC.**  
 CIVIL & STRUCTURAL ENGINEERS

**HLR** 3085 STEVENSON DRIVE, SUITE 201  
 SPRINGFIELD, ILLINOIS 62703  
 (217) 546-3400

ELGIN • SPRINGFIELD • DUQUOIN

PROJECT NUMBER: 12-23-0025-1 DATE: 05/10/06  
 DESIGNED: J.W.F. CHECKED: S.W.M. DRAWN: D.T.M.

**NORTH ABUTMENT**  
 SECTION 05-00261-00-BR  
 F.A.S. 690 / C.H. 22 / FOX ROAD  
 CLARK COUNTY  
 STRUCTURE NO. 012-3333 / STATION 10+00