

FOR INDEX OF SHEETS, SEE SHEET NO. 3

09-22-2023 LETTING ITEM 013

STATE OF ILLINOIS  
DEPARTMENT OF TRANSPORTATION

F.A.I. RTE.	SECTION	COUNTY	TOTAL SHEETS	SHEET NO.
80	FAI 80 21 STRUCTURE 6	WILL	999-	1
		ILLINOIS	CONTRACT NO. 62R27	

\* 898 + 2 = 900 TOTAL SHEETS

D-91-207-19

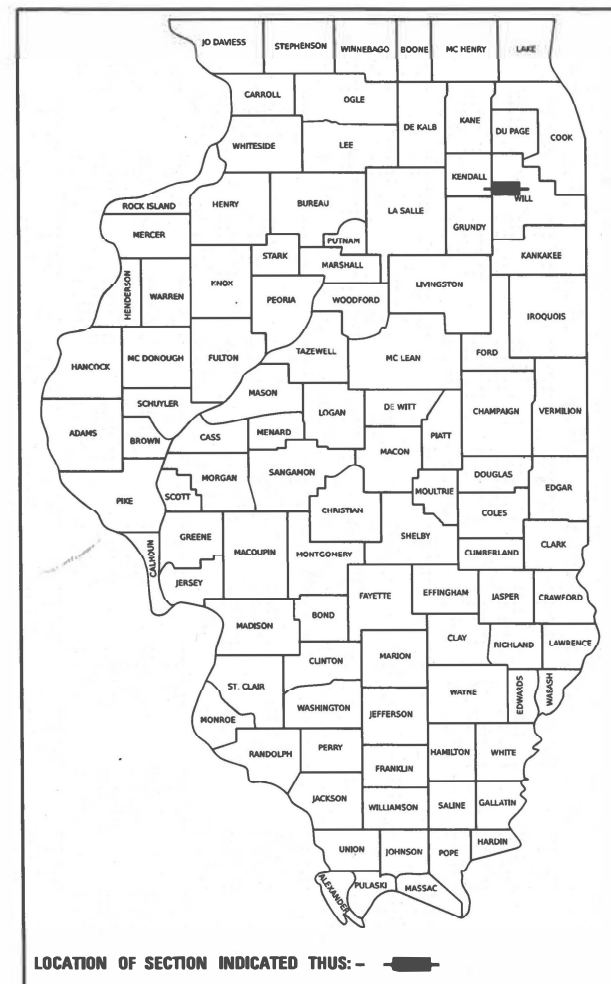

LOCATION OF SECTION INDICATED THIS: -

**TRANSYSTEMS** 1475 EAST WOODFIELD ROAD, SUITE 600  
SCHALMERSBURG, IL 60133  
PHONE: (847) 605-9600  
FAX: (847) 463-0565

**PROPOSED  
HIGHWAY PLANS**

**F.A.I. ROUTE 80 (I-80)  
SECTION FAI 80 21 STRUCTURE 6  
PROJECT NHPP-T8V5(526)  
RECONSTRUCTION, BRIDGE SUPERSTRUCTURE  
REPLACE, BRIDGE WIDENING, CULVERT (NEW),  
RAMP MODIFICATIONS, SHOULDER  
RECONSTRUCTION  
WILL COUNTY**

C-91-114-22

R 9 E

3rd PM

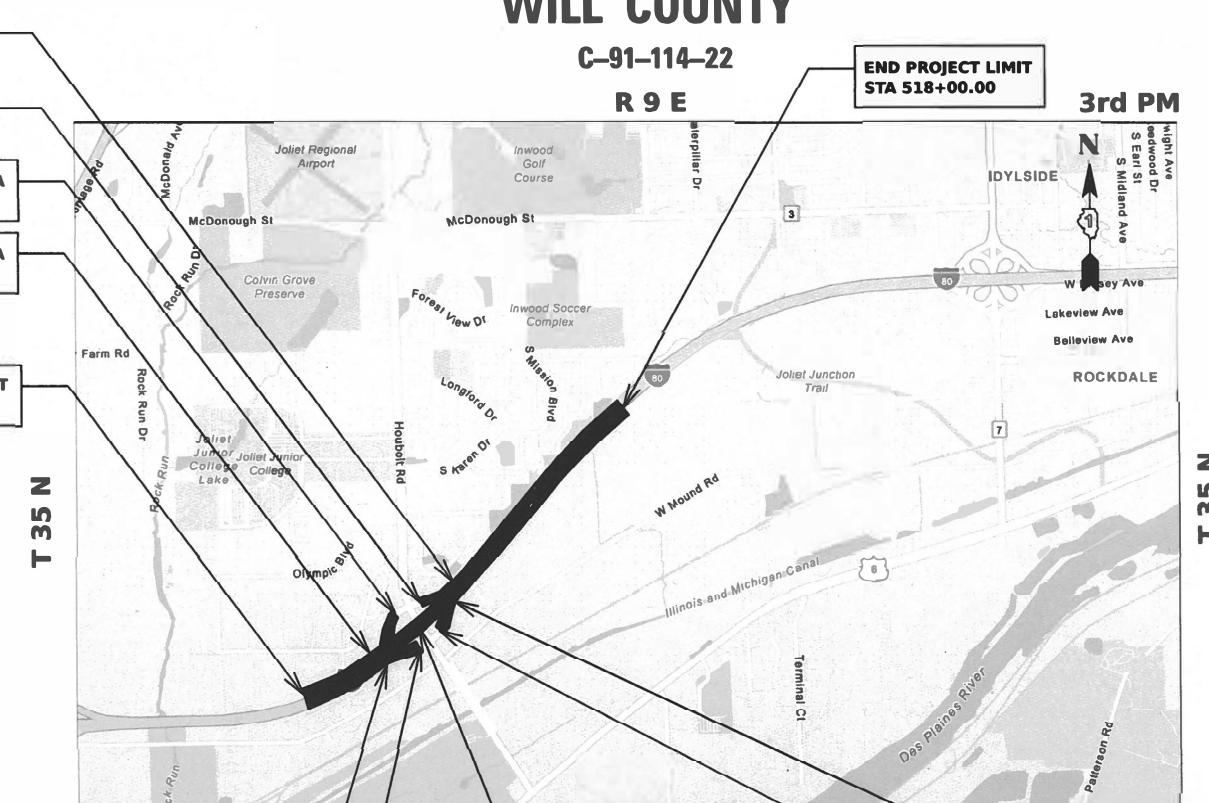

BEGIN HOUBOLT RAMP B  
STA 304+26.41

END HOUBOLT RAMP B  
STA 308+59.91

BEGIN HOUBOLT RAMP A  
STA 406+00.00

END HOUBOLT RAMP A  
STA 414+02.20

BEGIN PROJECT LIMIT  
STA 410+00.00

END PROJECT LIMIT  
STA 518+00.00

T 35 N

T 35 N

R 9 E

I-80 OVER HOUBOLT RD BRIDGE  
SN 099-0301 & 099-0302  
STA 443+94.70 TO  
STA 445+43.76

END HOUBOLT RAMP C  
STA 212+01.32

BEGIN HOUBOLT RAMP C  
STA 208+20.00

BEGIN HOUBOLT RAMP D  
STA 103+67.58

END HOUBOLT RAMP D  
STA 106+50.00

NOT TO SCALE  
GROSS LENGTH = 10,800.00 FT. = 2.045 MILE  
NET LENGTH = 10,800.00 FT. = 2.045 MILE

**DESIGN DESIGNATION**

14,400(35) INTERSTATE 135 (CRC-20)

**TRAFFIC DATA**

I-80 (I-55 TO HOUBOLT RD)  
EXISTING ADT: 65,200 (2019)  
DESIGN ADT: 93,900 (2040)  
DESIGN SPEED LIMIT: 70 MPH  
POSTED SPEED LIMIT: 65 MPH

I-80 (HOUBOLT RD TO LARKIN AVE)

EXISTING ADT: 67,430 (2019)  
DESIGN ADT: 90,100 (2040)  
DESIGN SPEED LIMIT: 70 MPH  
POSTED SPEED LIMIT: 65 MPH

**DESIGN DESIGNATION**

2,100(35) INTERSTATE RAMPS 135 (PCC-20)

**TRAFFIC DATA**

HOUBOLT RAMP A  
EXISTING ADT: 6,900 (2020)  
DESIGN ADT: 17,200 (2040)  
DESIGN SPEED LIMIT: 50 MPH  
POSTED SPEED LIMIT: 50 MPH

HOUBOLT RAMP B

EXISTING ADT: 5,400 (2020)  
DESIGN ADT: 11,000 (2040)  
DESIGN SPEED LIMIT: 50 MPH  
POSTED SPEED LIMIT: 50 MPH

HOUBOLT RAMP C

EXISTING ADT: 6,200 (2020)  
DESIGN ADT: 12,300 (2040)  
DESIGN SPEED LIMIT: 50 MPH  
POSTED SPEED LIMIT: 50 MPH

HOUBOLT RAMP D

EXISTING ADT: 6,900 (2020)  
DESIGN ADT: 17,400 (2040)  
DESIGN SPEED LIMIT: 50 MPH  
POSTED SPEED LIMIT: 50 MPH

**PROJECT LOCATED IN THE CITY OF JOLIET**

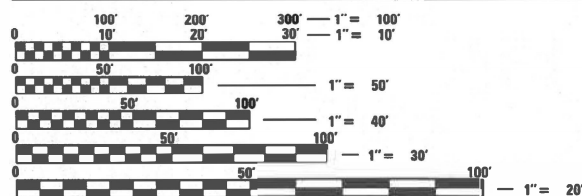

FULL SIZE PLANS HAVE BEEN PREPARED USING STANDARD ENGINEERING SCALES. REDUCED SIZED PLANS WILL NOT CONFORM TO STANDARD SCALES. IN MAKING MEASUREMENTS ON REDUCED PLANS, THE ABOVE SCALES MAY BE USED.

**FOR PROFESSIONAL SEALS  
SEE SHEET 2**

J.U.L.I.E.  
JOINT UTILITY LOCATION INFORMATION FOR EXCAVATION  
1-800-892-0123  
OR 811

MEADE ELECTRIC CO. DISTRICT ONE ELECTRICAL  
MAINTENANCE CONTRACTOR LOCATES IDOT ELECTRICAL  
EQUIPMENT AND UNDERGROUND CABLES  
773-287-7672

PROJECT ENGINEER: KEN PARK, PE  
PROJECT MANAGER: SULEYMAN TULGAR, PE

CONTRACT NO. 62R27

STATE OF ILLINOIS  
DEPARTMENT OF TRANSPORTATION

SUBMITTED JUNE 12 20 23  
Ken Park REGIONAL ENGINEER  
August 18, 2023  
Steph A. Etk  
ENGINEER OF DESIGN AND ENVIRONMENT  
August 18, 2023  
Steph M. Smith  
DIRECTOR OF HIGHWAYS PROJECT IMPLEMENTATION

PRINTED BY THE AUTHORITY  
OF THE STATE OF ILLINOIS

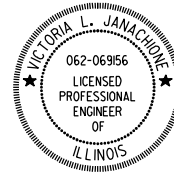

*Victoria L. Janachione* 6/5/2023  
**VICTORIA L. JANACHIONE** DATE  
 LICENSE EXPIRES 11/30/2023  
 SHEET RANGE 1-105, 295-304, 333-365, 397-407, 650, 661-898

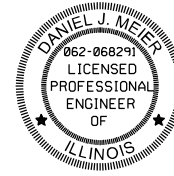

*Dan Meier* 6/5/2023  
**DANIEL J. MEIER** DATE  
 LICENSE EXPIRES 11/30/2023  
 SHEET RANGE 461-496

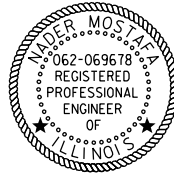

*Nader Mostafa* 6/5/2023  
**NADER MOSTAFA** DATE  
 LICENSE EXPIRES 11/30/2023  
 SHEET RANGE 106-212

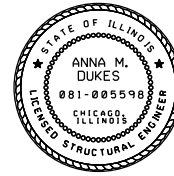

*Anna M. Dukes* 6/5/2023  
**ANNA M. DUKES** DATE  
 LICENSE EXPIRES 11/30/2024  
 SHEET RANGE 512-606



*Matthew T. Kuehl* 6/5/2023  
**MATTHEW T. KUEHL** DATE  
 LICENSE EXPIRES 11/30/2023  
 SHEET RANGE 213-257



*Demir Dabezic* 6/5/2023  
**DEMIR DABEZIC** DATE  
 LICENSE EXPIRES 11/30/2024  
 SHEET RANGE 607-616



*Dave Cook* 6/5/2023  
**DAVE COOK** DATE  
 LICENSE EXPIRES 11/30/2023  
 SHEET RANGE 258-294



*Patrick T. Jordan* 6/5/2023  
**PATRICK T. JORDAN** DATE  
 LICENSE EXPIRES 11/30/2023  
 SHEET RANGE 408-426



*Ahmed I. BEE* 6/5/2023  
**AHMEDI BEE** DATE  
 LICENSE EXPIRES 11/30/2023  
 SHEET RANGE 305-332, 366-373

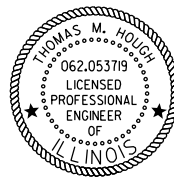

*Thomas M. Hough* 6/5/2023  
**THOMAS M. HOUGH** DATE  
 LICENSE EXPIRES 11/30/2023  
 SHEET RANGE 497-511



*Moussa A. Issa* 6/5/2023  
**MOUSSA A. ISSA** DATE  
 LICENSE EXPIRES 11/30/2024  
 SHEET RANGE 374-396, 617-649, 651-660

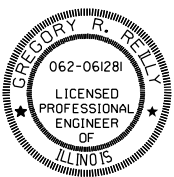

*Gregory R. Reilly* 6/5/2023  
**GREGORY R. REILLY** DATE  
 LICENSE EXPIRES 11/30/2023  
 SHEET RANGE 427-460

MODEL: SE-A-01  
 FILE NAME: p:\transystems\pwwork\transystems\pwwork\hosted\Documents\Projects\_2018\CH401\401180022\02-TransSystems\CAD\62R27\Sheets\01-General\0162R27-Cover\_Sheet

**TRANSYSTEMS**

USER NAME = amkluver	DESIGNED - VLJ	REVISED -
PLOT SCALE = 0.16666633 1/ in.	DRAWN - AMK	REVISED -
PLOT DATE = 6/5/2023	CHECKED - JMG	REVISED -
	DATE - 6/26/23	REVISED -

**STATE OF ILLINOIS  
 DEPARTMENT OF TRANSPORTATION**

**PROFESSIONAL SEALS**  
 SCALE: NONE SHEET 1 OF 1 SHEETS STA. TO STA.

F.A.I. RTE.	SECTION	COUNTY	TOTAL SHEETS	SHEET NO.
I-80	FAI 80 21 STRUCTURE 6	WILL	898	2
CONTRACT NO. 62R27				
ILLINOIS FED. AID PROJECT				



MODEL: GEN-01  
 FILE NAME: p:\transystems-pw\kentley.com\transyscorp-pw\hosted\Documents\Projects\_2018\CH-401\401180022\02-TransSystems\CD\62R27\62R27-Index\_Sheet

SHEET NO.	INDEX OF SHEETS DESCRIPTION
1	COVER SHEET
2	PROFESSIONAL SEALS
3	INDEX OF SHEETS AND STANDARDS
4	GENERAL NOTES
5-20	SUMMARY OF QUANTITIES
21-31	TYPICAL SECTIONS
32-34	ROADWAY SCHEDULES
35-42	ALIGNMENT, TIES AND BENCHMARKS
43	KEY PLAN
44-53	REMOVAL PLAN
54-63	ROADWAY PLAN
64-75	ROADWAY PROFILE
76-85	JOINTING AND SUPERELEVATION PLANS
86-91	SUPERELEVATION DETAILS
92-95	JOINTING DETAILS
96-103	GORE GRADING DETAILS
104-105	ROADWAY DETAILS
106	SUGGESTED STAGES OF CONSTRUCTION AND TRAFFIC CONTROL PLAN - GENERAL NOTES
107-128	SUGGESTED STAGES OF CONSTRUCTION AND TRAFFIC CONTROL PLAN - DETAILS
129-147	SUGGESTED STAGES OF CONSTRUCTION AND TRAFFIC CONTROL PLAN - PRE-STAGE 1
148-157	SUGGESTED STAGES OF CONSTRUCTION AND TRAFFIC CONTROL PLAN - PRE-STAGE 2
158-167	SUGGESTED STAGES OF CONSTRUCTION AND TRAFFIC CONTROL PLAN - PRE-STAGE 3
168-178	SUGGESTED STAGES OF CONSTRUCTION AND TRAFFIC CONTROL PLAN - STAGE 1
179	SUGGESTED STAGES OF CONSTRUCTION AND TRAFFIC CONTROL PLAN - STAGE 2
180-192	SUGGESTED STAGES OF CONSTRUCTION AND TRAFFIC CONTROL PLAN - STAGE 2A
193-202	SUGGESTED STAGES OF CONSTRUCTION AND TRAFFIC CONTROL PLAN - STAGE 2B
203-212	SUGGESTED STAGES OF CONSTRUCTION AND TRAFFIC CONTROL PLAN - STAGE 3
213-214	EROSION AND SEDIMENTATION CONTROL - GENERAL NOTES
215-216	EROSION AND SEDIMENTATION CONTROL - SCHEDULE
217-256	EROSION AND SEDIMENTATION CONTROL - PLAN
257	EROSION AND SEDIMENTATION CONTROL - DETAILS
258-260	DRAINAGE AND UTILITY SCHEDULES
261-270	EXISTING DRAINAGE AND UTILITIES PLAN
271-280	PROPOSED DRAINAGE AND UTILITIES PLAN
281-290	DRAINAGE AND UTILITIES PROFILE
291-294	DRAINAGE AND UTILITIES: DETAILS
295-304	UTILITY LOCATION PLANS
305	PAVEMENT MARKING AND SIGNING GENERAL NOTES
306-307	PAVEMENT MARKING SCHEDULE
308-317	PAVEMENT MARKING PLAN
318-322	SIGNING SCHEDULE
323-332	SIGNING PLAN
333-365	SIGN PANEL DETAILS
366-373	SIGN MOUNTING DETAILS
374-396	OVERHEAD SIGN STRUCTURE DETAILS (STANDARD)
397-407	LANDSCAPING PLANS
408-414	TRAFFIC SIGNAL - DISTRICT 1 DETAILS
415-426	TRAFFIC SIGNAL PLAN
427	IDOT ELECTRICAL SYMBOLS
428	LIGHTING NOTES, ABBREVIATIONS, AND QUANTITIES
429-433	EXISTING LIGHTING PLAN
434-438	HOUBOLT INTERCHANGE TEMPORARY LIGHTING PLAN
439-448	PROPOSED LIGHTING PLAN
449	HOUBOLT ROAD UNDERPASS LIGHTING PLAN
450	WIRING DIAGRAMS
451-460	LIGHTING DETAILS
461-463	GENERAL ITS
464-473	ITS REMOVAL PLANS
474-484	ITS INFRASTRUCTURE PLANS
485-495	ITS INFRASTRUCTURE DETAILS
496	SMART TRAFFIC MONITORING SYSTEM
497-499	ITS CROSS SECTIONS
500-511	ITS OVERHEAD SIGN STRUCTURES
512-558	PROPOSED BRIDGE PLANS (SN 099-0301 & 099-0302)
559-606	EXISTING BRIDGE PLANS (SN 099-0301 & 099-0302)
607-616	PROPOSED CULVERT PLANS (SN 099-0760)
617-650	NOISE ABATEMENT WALLS
651-660	ANCHORAGE SLABS
661-680	DISTRICT 1 STANDARD DETAILS

SHEET NO.	INDEX OF SHEETS (CONT.) DESCRIPTION
681-723	CROSS SECTIONS PRE-STAGE - I-80
724-770	CROSS SECTIONS STAGE 1 - I-80
771-853	CROSS SECTIONS STAGE 2 - I-80
854-855	CROSS SECTIONS CROSSING CULVERT
856-862	CROSS SECTIONS STAGE 2 - HOUBOLT RAMP A
863-871	CROSS SECTIONS STAGE 2 - HOUBOLT RAMP B
872-880	CROSS SECTIONS STAGE 3 - HOUBOLT RAMP B
881-884	CROSS SECTIONS STAGE 2 - HOUBOLT RAMP C
885-889	CROSS SECTIONS STAGE 3 - HOUBOLT RAMP C
890-898	CROSS SECTIONS STAGE 2 - HOUBOLT RAMP D

STANDARD NO.	IDOT HIGHWAY STANDARDS DESCRIPTION
000001 - 08	STANDARD SYMBOLS, ABBREVIATIONS AND PATTERNS
001001 - 02	AREAS OF REINFORCEMENT BARS
001006	DECIMAL OF AN INCH AND OF A FOOT
280001 - 07	TEMPORARY EROSION CONTROL SYSTEMS
420001 - 10	PAVEMENT JOINTS
420101 - 07	24' (7.2m) JOINTED PCC PAVEMENT
420106 - 07	36' (10.8m) JOINTED PCC PAVEMENT
420111 - 04	PCC PAVEMENT ROUNDOUTS
420206 - 13	ENTRANCE RAMP TERMINAL JOINTED PCC RAMP PAVEMENT ADJACENT TO CRC MAINLINE PAVEMENT
420306 - 11	EXIT RAMP TERMINAL JOINTED PCC RAMP PAVEMENT ADJACENT TO CRC MAINLINE PAVEMENT
420401 - 13	PAVEMENT CONNECTOR (PCC) FOR BRIDGE APPROACH SLAB
420701 - 03	PAVEMENT WELDED WIRE REINFORCEMENT
421001 - 03	BAR REINFORCEMENT FOR CRC PAVEMENT
421201 - 07	24' (7.2m) CRC PAVEMENT (WITH LUG SYSTEM)
421206 - 07	36' (10.8m) CRC PAVEMENT (WITH LUG SYSTEM)
483001 - 06	PCC SHOULDER
515001 - 04	NAME PLATE FOR BRIDGES
542001 - 06	CONCRETE END SECTIONS FOR PIPE CULVERTS 15" (375mm) THRU 84" (2100mm) DIA.
601001 - 05	PIPE UNDERDRAINS
602001 - 02	CATCH BASIN, TYPE A
602011 - 02	CATCH BASIN, TYPE C
602106 - 03	DRAINAGE STRUCTURES, TYPES 4 & 5
602301 - 04	INLET - TYPE A
602401 - 07	PRECAST MANHOLE TYPE A 4' (1.22m) DIAMETER
602402 - 03	PRECAST MANHOLE TYPE A 5' (1.52m) DIAMETER
602406 - 11	PRECAST MANHOLE TYPE A 6' (1.83m) DIAMETER
602411 - 09	PRECAST MANHOLE TYPE A, 7' (2.13m) DIAMETER
602416 - 09	PRECAST MANHOLE TYPE A 8' (2.44m) DIAMETER
602421 - 09	PRECAST MANHOLE TYPE A 9' (2.74m) DIAMETER
602426 - 03	PRECAST MANHOLE TYPE A 10' (3.05m) DIAMETER
602601 - 06	PRECAST REINFORCED CONCRETE FLAT SLAB TOP
602701 - 02	MANHOLE STEPS
604001 - 04	FRAME AND LIDS TYPE 1
604031 - 03	GRATE, TYPE 7
604036 - 03	GRATE TYPE 8
604046 - 03	FRAME AND GRATE TYPE 10
604071 - 05	FRAME AND GRATE TYPE 20
604081 - 06	FRAMES AND GRATES, TYPE 22
606001 - 08	CONCRETE CURB TYPE B AND COMBINATION CONCRETE CURB AND GUTTER
606101 - 05	TYPE A GUTTER (INLET, OUTLET & ENTRANCE)
630001 - 12	STEEL PLATE BEAM GUARDRAIL
630106 - 02	LONG-SPAN GUARDRAIL OVER CULVERT
630201 - 07	PCC/HMA STABILIZATION AT STEEL PLATE BEAM GUARDRAIL
630301 - 09	SHOULDER WIDENING FOR TYPE 1 (SPECIAL) GUARDRAIL TERMINALS
631031 - 18	TRAFFIC BARRIER TERMINAL, TYPE 6
635001 - 02	DELINEATORS
637006 - 05	CONCRETE BARRIER, DOUBLE FACE, 44 IN (1120mm) HEIGHT
642001 - 03	SHOULDER RUMBLE STRIPS, 16 in
643001 - 02	SAND MODULE IMPACT ATTENUATORS
664001 - 02	CHAIN LINK FENCE
701001 - 02	OFF-ROAD OPERATIONS, 2L, 2W, MORE THAN 15' (4.5 m) AWAY
701006 - 05	OFF-ROAD OPERATIONS, 2L, 2W, 15' (4.5 m) TO 24" (600 m) FROM PAVEMENT EDGE
701011 - 04	OFF-ROAD MOVING OPERATIONS, 2L, 2W, DAY ONLY
701106 - 02	OFF-ROAD OPERATION, MULTILANE, MORE THAN 15' (4.5m) AWAY
701400 - 11	APPROACH TO LANE CLOSURE, FREEWAY/EXPRESSWAY
701401 - 13	LANE CLOSURE, FREEWAY/EXPRESSWAY
701411 - 09	LANE CLOSURE, MULTILANE, AT ENTRANCE OR EXIT RAMP, FOR SPEEDS GREATER THAN OR EQUAL TO 45 MPH
701428 - 01	TRAFFIC CONTROL, SETUP AND REMOVAL, FREEWAY/EXPRESSWAY
701446 - 09	TWO LANE CLOSURE, FREEWAY/EXPRESSWAY
701601 - 09	URBAN LANE CLOSURE, MULTILANE, 1W OR 2W WITH NONTRAVERSABLE MEDIAN
701606 - 10	URBAN SINGLE LANE CLOSURE, MULTILANE, 2W WITH MOUNTABLE MEDIAN
701801 - 06	SIDEWALK, CORNER OR CROSSWALK CLOSURE
701901 - 08	TRAFFIC CONTROL DEVICES
704001 - 08	TEMPORARY CONCRETE BARRIER
720001 - 01	SIGN PANEL MOUNTING DETAILS
720006 - 04	SIGN PANEL ERECTION DETAILS
720011 - 01	METAL POSTS FOR SIGNS MARKERS AND DELINEATORS
725001 - 01	OBJECT AND TERMINAL MARKERS
728001 - 01	TELESCOPING STEEL SIGN SUPPORT
729001 - 01	APPLICATIONS OF TYPES A & B METAL POSTS (FOR SIGN & MARKERS)
731001 - 01	BASE FOR TELESCOPING STEEL SIGN SUPPORT
780001 - 05	TYPICAL PAVEMENT MARKINGS
781001 - 04	TYPICAL APPLICATIONS RAISED REFLECTIVE PAVEMENT MARKERS
782006 - 01	GUARDRAIL AND BARRIER WALL REFLECTOR MOUNTING DETAILS
814001 - 03	HANDHOLES
878001 - 11	CONCRETE FOUNDATION DETAILS

**DISTRICT DETAILS**

IDOT D1 STANDARD NO.	DESCRIPTION
BD-07	DETAIL OF STORM SEWER CONNECTION TO EXISTING SEWER
BD-08	DETAILS FOR FRAMES AND LIDS ADJUSTMENT WITH MILLING
BD-34	DETAILS FOR DEPRESSED CURB & GUTTER AND SHOULDER TREATMENT AT TBT TY. 1 SPL.
BD-48	PCC PAVEMENT ROUNDOUTS AT CURB AND GUTTER
BD-49	DETAIL FOR CENTERLINE SAW CUT 16' (4.9m) AND VARIABLE JOINT PCC PAVEMENT FOR RAMP
BD-51	BENCHING DETAIL FOR EMBANKMENT WIDENING
TC-08	ENTRANCE AND EXIT RAMP CLOSURE DETAILS
TC-09	TRAFFIC CONTROL DETAILS FOR FREEWAY SINGLE & MULTI-LANE WEAVE
TC-10	TRAFFIC CONTROL AND PROTECTION FOR SIDE ROADS, INTERSECTIONS, AND DRIVEWAYS
TC-11	TYPICAL APPLICATIONS RAISED REFLECTIVE PAVEMENT MARKERS (SNOW PLOW RESISTANT)
TC-12	MULTI-LANE FREEWAY PAVEMENT MARKING DETAILS (2 SHEETS)
TC-13	DISTRICT ONE TYPICAL PAVEMENT MARKINGS
TC-16	SHORT TERM PAVEMENT MARKING LETTERS AND SYMBOLS
TC-17	TRAFFIC CONTROL DETAILS FOR FREEWAY SHOULDER CLOSURES AND PARTIAL RAMP CLOSURES
TC-18	FREEWAY/EXPRESSWAY SIGNING FOR FLAGGING OPERATIONS AT WORK ZONE
TC-22	OPENINGS ON FREEWAY/EXPRESSWAYS
TC-25	ARTERIAL ROAD INFORMATION SIGN
TC-27	FREEWAY CENTER LANE CLOSURE SHOULDER LANE
TC-33	MILE POST MARKERS - GORE SIGNS - MAJOR GUIDE SIGN LAYOUT - ARROWS
	SMART TRAFFIC MONITORING SYSTEM - TYPICAL LAYOUT



USER NAME = amkluver	DESIGNED - VLJ	REVISED -
PLOT SCALE = 0.16666633' / in.	DRAWN - AMK	REVISED -
PLOT DATE = 8/10/2023	CHECKED - JMG	REVISED -
	DATE - 8/10/2023	REVISED -

**STATE OF ILLINOIS  
DEPARTMENT OF TRANSPORTATION**

<b>INDEX OF SHEETS AND STANDARDS</b>				
SCALE:	SHEET 1	OF 2	SHEETS	STA. TO STA.

F.A.I. RTE.	SECTION	COUNTY	TOTAL SHEETS	SHEET NO.
I-80	FAI 80 21 STRUCTURE 6	WILL	898	3
			CONTRACT NO. 62R27	
		ILLINOIS	FED. AID PROJECT	

**GENERAL NOTES**

1. ALL ELEVATIONS IN THE PLANS ARE BASED UPON THE NORTH AMERICAN VERTICAL DATUM OF 1988 (NAVD88), UNLESS OTHERWISE NOTED. HORIZONTAL DATUM IS REFERENCED TO ILLINOIS STATE PLAN COORDINATE SYSTEM, EAST ZONE, NAD83 (2011) UNLESS OTHERWISE NOTED.
2. A MINIMUM OF SEVENTY-TWO (72) HOURS BEFORE STARTING ANY EXCAVATION, THE CONTRACTOR SHALL CALL J.U.L.I.E. AT (800-892-0123) OR 811 TO HAVE THE LOCATION OF EXISTING UNDERGROUND UTILITIES MARKED IN THE FIELD.
3. TWO (2) WEEKS PRIOR TO PLACING PERMANENT PAVEMENT MARKINGS, THE ENGINEER SHALL CONTACT THE ARTERIAL TRAFFIC FIELD ENGINEER ERIC CAMPOS AT ERIC.CAMPOS@ILLINOIS.GOV FOR ARTERIAL ROADWAYS, AND THE EXPRESSWAY TRAFFIC FIELD ENGINEER REGINA COOPER AT REGINA.COOPER2@ILLINOIS.GOV FOR EXPRESSWAYS OR CALL THE BUREAU OF TRAFFIC AT (847) 705-4151.
4. THE CONTRACTOR SHALL CONTACT THE DISTRICT ONE TRAFFIC CONTROL SUPERVISOR AT (847) 705-4151 FOR EXPRESSWAYS AND (847) 705-4470 FOR ARTERIALS A MINIMUM OF 72 HOURS IN ADVANCE OF BEGINNING WORK.
5. THE CONTRACTOR MUST CALL THE IDOT ELECTRICAL MAINTENANCE CONTRACTOR TO LOCATE IDOT FACILITY CABLES.
6. PLAN DIMENSIONS AND DETAILS RELATIVE TO EXISTING PLANS ARE SUBJECT TO ROUTINE VARIATIONS. IT SHALL BE THE CONTRACTOR'S RESPONSIBILITY TO VERIFY ALL DIMENSIONS AND CONDITIONS EXISTING IN THE FIELD PRIOR TO CONSTRUCTION AND ORDERING OF MATERIALS. SUCH VARIATIONS SHALL NOT BE CAUSE FOR ADDITIONAL COMPENSATION FOR A CHANGE IN THE SCOPE OF THE WORK, HOWEVER, THE CONTRACTOR WILL BE PAID FOR THE QUANTITY ACTUALLY FURNISHED BASED UPON THE UNIT PRICE BID FOR THE WORK. CONTRACTOR SHALL NOT SCALE DIMENSIONS FROM THE CONTRACT PLANS FOR CONSTRUCTION PURPOSES.
7. THE CONTRACTOR WILL NOT BE ALLOWED TO SET UP A YARD OR FIELD OFFICE ON STATE OR CITY PROPERTY WITHOUT WRITTEN PERMISSION FROM THE DEPARTMENT.
8. ALL ROADWAY WIDTHS AND RADII SHOWN ON THE PLANS ARE TO THE EDGE OF PAVEMENT UNLESS OTHERWISE NOTED.
9. THE LOCATIONS AND/OR DEPTHS OF PUBLIC OR PRIVATE UTILITIES SHOWN ON THE PLAN ARE APPROXIMATE AND THEIR ACCURACY IS NOT GUARANTEED. THE CONTRACTOR SHALL VERIFY THE EXACT LOCATION AND ELEVATION OF ALL UTILITIES. THE CONTRACTOR SHALL REPORT ANY ENCOUNTERED DISCREPANCIES TO THE ENGINEER AT ONCE. THE CONTRACTOR SHALL TAKE DUE CARE. THE CONTRACTOR SHALL BE RESPONSIBLE FOR THE PROTECTION OF ALL UNDERGROUND OR SURFACE UTILITIES EVEN THOUGH THEY MAY NOT BE SHOWN IN THE PLANS. ANY UTILITY THAT IS DAMAGED DURING CONSTRUCTION SHALL BE REPAIRED OR REPLACED TO THE SATISFACTION OF THE ENGINEER. THIS WORK SHALL BE AT THE CONTRACTOR'S EXPENSE.
10. FRAMES AND GRATES ADJUSTMENT OF PRIVATE UTILITIES WITHIN THE LIMITS OF THE IMPROVEMENTS SHALL BE DONE BY THEIR RESPECTIVE OWNERS AND ARE NOT PART OF THIS CONTRACT.
11. THE PAVEMENT ELEVATIONS SHOWN ON THE PLANS ARE FINISHED GRADES OR SURFACE COURSE, UNLESS OTHERWISE INDICATED.
12. THE ACTUAL LOCATION OF PROPOSED LANDSCAPING WILL BE ADJUSTED IN THE FIELD TO AVOID UTILITIES. INTERFERE WITH CONSTRUCTION OPERATIONS.
13. DRAINAGE
  - A) THE OFFSETS AND TOP OF FRAME OR LID ELEVATIONS FOR DRAINAGE STRUCTURES WERE DETERMINED USING THE CRITERIA LISTED BELOW UNLESS OTHERWISE NOTED:
    - I. THE OFFSETS TO ALL INLETS AND CATCH BASINS IN ROADWAYS WITH BARRIER WALL ARE TO THE FLOWLINE. SEE DRAINAGE DETAILS SHEET NO. 292 FOR ADDITIONAL INFORMATION. STRUCTURES SHALL BE TURNED SO THAT THE FRAME IS CLOSEST TO THE CENTER LINE OF THE ROAD UNLESS OTHERWISE NOTED ON THE PLANS.
    - II. THE OFFSETS TO ALL INLETS AND CATCH BASINS IN CURBED ROADWAYS ARE TO THE FLOWLINE, STRUCTURES LOCATED IN THE GUTTER SHALL BE TURNED SO THAT THE FRAME IS CLOSEST TO THE CENTER LINE OF THE ROAD UNLESS OTHERWISE NOTED ON THE PLANS
    - III. THE OFFSETS TO MANHOLES, STRUCTURES IN GORE AREAS, AND STRUCTURES IN INFIELD AREAS ARE TO THE CENTER OF THE STRUCTURE. STRUCTURES LOCATED SHALL BE TURNED SO THAT THE FRAME IS CLOSEST TO THE CENTER LINE OF THE ROAD UNLESS OTHERWISE NOTED ON THE PLANS.
    - IV. THE OFFSETS TO INLETS AND CATCH BASINS IN CONCRETE GUTTERS BEHIND BARRIER WALLS ARE TO BE THE FLOWLINE. SEE DRAINAGE DETAILS SHEET NO. 292 FOR ADDITIONAL INFORMATION. STRUCTURES LOCATED SHALL BE TURNED SO THAT THE FRAME IS CLOSEST TO THE CENTER LINE OF THE ROAD UNLESS OTHERWISE NOTED ON THE PLANS.
  - B) DRAINAGE GRADES SHALL BE VERIFIED IN FIELD PRIOR TO INSTALLATION OF DRAINAGE ITEMS.
  - C) DRAINAGE ADJUSTMENT OR RECONSTRUCTION LOCATIONS WILL BE DETERMINED IN THE FIELD BY THE ENGINEER
  - D) STORM SEWER CONSTRUCTED UNDER THE ROADWAY SHALL BE BACKFILLED ACCORDING TO METHOD 1 OF ARTICLE 550.07 OF THE STANDARD SPECIFICATIONS.
  - E) THE CONTRACTOR SHALL BE REQUIRED TO KEEP A RECORD OF THE LOCATIONS OF PLATED STRUCTURES BY STATION AND OFFSET LEFT OR RIGHT OF THE CENTERLINE OF PAVEMENT.
  - F) THE CONTRACTOR SHALL BE REQUIRED TO KEEP A RECORD OF THE LOCATIONS OF THE BURIED STRUCTURES ACCORDING TO THE STATION AND DISTANCE LEFT OR RIGHT OF THE CENTERLINE OF PAVEMENT. UPON COMPLETION OF THE WORK, THE CONTRACTOR SHALL DELIVER THE RECORD TO THE ENGINEER.
  - G) EXISTING BROKEN FRAMES AND LIDS SHALL BE REMOVED AND DISPOSED OF BY THE CONTRACTOR AND SHALL BE REPLACED AS DIRECTED BY THE ENGINEER. REPLACEMENT FRAMES AND LIDS WILL BE PAID FOR ACCORDING TO ARTICLE 109.04 OF THE STANDARD SPECIFICATIONS UNLESS A SEPARATE PAY ITEM HAS BEEN PROVIDED.
  - H) THE CONTRACTOR SHALL VERIFY THE EXISTING OUTLET STRUCTURE LOCATIONS AND INVERTS PRIOR TO STARTING UPSTREAM STORM SEWER CONNECTION AND CONSTRUCTION.
  - I) PROPOSED RIM AND INVERT ELEVATIONS ARE BASED ON EXISTING THEORETICAL GRADES. ACTUAL FINAL GRADES ARE SUBJECT TO NOMINAL VARIATIONS. ADJUSTMENTS OF PROPOSED CASTINGS TO FINAL GRADES IS INCLUDED IN THE COST OF THE RELATED DRAINAGE STRUCTURE. ADJUSTMENT OF THE PROPOSED PIPE INVERTS TO FINAL GRADES IS INCLUDED IN THE COST OF THE RELATED DRAINAGE PIPE.

14. FOR WORK OUTSIDE THE LIMITS OF BRIDGE APPROACH PAVEMENT, ALL REFERENCES IN THE HIGHWAY STANDARDS AND STANDARD SPECIFICATIONS FOR REINFORCEMENT, DOWEL BARS AND TIE BARS IN PAVEMENT, SHOULDERS, CURB, GUTTER, COMBINATION CURB AND GUTTER AND MEDIAN, AND CHAIR SUPPORTS FOR CRC PAVEMENT, SHALL BE EPOXY COATED, UNLESS NOTED ON THE PLAN.
15. THE THICKNESS OF THE HOT-MIX ASPHALT MIXTURE SHOWN ON THE PLANS IS THE NOMINAL THICKNESS. DEVIATIONS FROM THE NOMINAL THICKNESS WILL BE PERMITTED WHEN SUCH DEVIATIONS OCCUR DUE TO IRREGULARITIES IN THE EXISTING SURFACE OR BASE ON WHICH THE HOT-MIX ASPHALT MIXTURE IS PLACED.
16. THE DEPARTMENT HAS NOT OBTAINED ANY PERMITS FOR OFFSITE BORROW, WASTE, USE (BWU) AREAS PRIOR TO WORKING IN BWU AREAS, IF THE CONTRACTOR CHOOSES TO USE ACTIVITIES REQUIRING PERMITS IT IS THE CONTRACTOR'S RESPONSIBILITY TO SECURE THE PROPER PERMITS. IN ADDITION TO THE BORROW REVIEW (BDE 2289) AND USE/WASTE REVIEW (BDE 2290) SUBMITTALS, THE CONTRACTOR SHALL SUBMIT AN EROSION AND SEDIMENT CONTROL (ESC) PLAN FOR EVERY BWU SITE TO THE DEPARTMENT FOR ACCEPTANCE. GUIDELINES FOR ACCEPTABLE BWU PRACTICES CAN BE FOUND IN SECTION II.G.1 AND 2 OF THE SWPPP. THE COST OF ALL MATERIALS AND LABOR NECESSARY TO COMPLY WITH THE ABOVE PROVISIONS TO PREPARE AND IMPLEMENT ESC PLANS WILL NOT BE PAID FOR SEPARATELY, BUT SHALL BE CONSIDERED AS INCLUDED IN THE UNIT BID PRICES OF THE CONTRACT AND NO ADDITIONAL COMPENSATION WILL BE ALLOWED.
17. REMOVAL OF EXISTING PIPE UNDERDRAIN AND PIPE UNDERDRAIN OUTFALL STRUCTURES ARE INCLUDED IN THE PRICE OF EARTH EXCAVATION.
18. WHEN ARTIFICIAL LIGHTING IS USED IN NIGHT OPERATIONS THE CONTRACTOR SHALL EXERCISE THE UTMOST PRECAUTIONS IN PREVENTING ADVERSE VISIBILITY TO THE MOTORING PUBLIC, AIR TRAFFIC AND ADJOINING RESIDENTIAL AND COMMERCIAL AREAS.
19. THIS PROJECT REQUIRES A US ARMY CORPS OF ENGINEERS (USACE) 404 PERMIT THAT WILL BE SECURED BY THE DEPARTMENT. AS A CONDITION OF THIS PERMIT, THE CONTRACTOR WILL NEED TO SUBMIT AN IN-STREAM WORK PLAN TO THE DEPARTMENT FOR APPROVAL. GUIDELINES ON ACCEPTABLE IN-STREAM WORK TECHNIQUES CAN BE FOUND ON THE USACE WEBSITE. THE USACE DEFINES AND DETERMINES IN-STREAM WORK. THE COST OF ALL MATERIALS AND LABOR NECESSARY TO COMPLY WITH THE ABOVE PROVISIONS TO PREPARE AND IMPLEMENT AN IN-STREAM WORK PLAN WILL NOT BE PAID FOR SEPERATELY, BUT SHALL BE CONSIDERED AS INCLUDED IN THE UNIT BID PRICES OF THE CONTRACT AND NO ADDITIONAL COMPENSATION WILL BE ALLOWED.
20. PIPE UNDERDRAINS SHALL BE INSTALLED ACCORDING TO SECTION 601 OF THE SSRBC AND STANDARD 601001-05. TOP OF PIPE UNDERDRAINS SHALL BE PLACED A MINIMUM OF 6" BELOW THE AGGREGATE SUBGRADE IMPROVEMENT LAYER. THE COST OF MAKING PIPE UNDERDRAINS CONNECTIONS TO DRAINAGE STRUCTURES SHALL BE INCLUDED IN THE COST OF THE PIPE UNDERDRAINS.
21. BACKFILLING STORM SEWER CONSTRUCTED UNDER THE ROADWAY SPECIFIED UNDER ART. 550.07(b, c) OF THE SSRBC WILL NOT BE ALLOWED.
22. CONTRACTOR SHALL CONTACT THE ROADSIDE DEVELOPMENT UNIT AT (847) 705-4171 AT LEAST 2 WEEKS PRIOR TO WEED CONTROL AND FORESTRY WORK TO IDENTIFY AND MARK TREES TO SAVE WITHIN TREE REMOVAL AND CLEARING AREAS.
23. PAY ITEMS 42100360 CONT REINF PCC PVT 13, 48300800 PCC SHOULDERS 13, 42000531 PCC PVT 11½" (JOINTED) & 48300610 PCC SHOULDERS 11½" SHALL BE CONSTRUCTED FOLLOWING THE EXTENDED LIFE CONCRETE PAVEMENT SPECIAL PROVISION.
24. THE "ARTERIAL ROAD INFORMATION SIGN (TC-22)" IS APPLICABLE ONLY TO ARTERIAL ROADS AND SHALL NOT BE APPLIED TO EXPRESSWAYS/TOLLWAYS
25. IDOT FACILITIES ARE NOT LOCATED BY JULIE OR DIGGER. IDOT ELECTRICAL FACILITIES INCLUDING ROADWAY LIGHTING, FIBER OPTIC, ITS EQUIPMENT, TRAFFIC SIGNAL FACILITIES ARE LOCATED BY THE DEPARTMENT'S ELECTRICAL MAINTENANCE CONTRACTOR. AS OF THE LETTING DATE, CONTACT MEADE ELECTRIC COMPANY AT 773-287-7672.
26. ROCK EXCAVATION IS EXPECTED FOR PLACEMENT OF A PORTION OF PROPOSED STORM SEWER. AN APPROX. QUANTITY OF ROCK EXCAVATION BASED OFF PLAN BORINGS IS SHOWN IN THE DRAIN SCHEDULES BUT SHOULD BE CONFIRMED BY THE ENGINEER IN THE FIELD. ROCK ECAVATION RELATED TO PLACEMENT OF PROPOSED STORM SEWER WILL BE PAID FOR EACH PIPE SECTION PER SECTION 550.10 AND 502.12 OF THE IDOT SSRBC.

**COMMITMENTS**

1. TO AVOID AND MINIMIZE IMPACTS TO THE INDIANA BAT AND NORTHERN LONG-EARED BAT, NO TREE CLEARING SHALL OCCUR FROM APRIL 1 TO OCTOBER 31. SEE REMOVAL PLANS.
2. THE CONTRACTOR SHALL IMPLEMENT A STANDARD DUST CONTROL PLAN TO MINIMIZE DUST FROM THE CONSTRUCTION SITE AND ACTIVITIES. REFER TO DUST CONTROL WATERING AND STANDARD SPECIFICATION ARTICLE 107.36 FOR DETAILS.

MODEL: GEN-03  
 FILE NAME: p:\transystems-pw\hntb\comtransyscorp\pw-hntb\Documents\Projects\_2018\C440118002702-Transystems\CAD\62R27\Sheets\01-General\01-62R27-General.dwg



USER NAME = amkluver	DESIGNED - VLJ	REVISED -
	DRAWN - AMK	REVISED -
PLOT SCALE = 0.16666000 ' / in.	CHECKED - JMG	REVISED -
PLOT DATE = 6/22/2023	DATE - 6/26/23	REVISED -

**STATE OF ILLINOIS  
DEPARTMENT OF TRANSPORTATION**

**GENERAL NOTES**

SCALE: SHEET 2 OF 2 SHEETS STA. TO STA.

F.A.I. RTE.	SECTION	COUNTY	TOTAL SHEETS	SHEET NO.
I-80	FAI 80 21 STRUCTURE 6	WILL	898	4
CONTRACT NO. 62R27				
		ILLINOIS	FED. AID PROJECT	

MODEL: S00-01  
 FILE NAME: p:\transys\transys\comp\pw\_bentley.com\transys\comp\pw\_bentled\Documents\Projects\_2018\CH401401180022\02-TransSystems\CAD\02R27\02R27\02R27-SHT-S00.dgn

CODE NUMBER	PAY ITEM	UNIT	TOTAL QUANTITY	ROADWAY	ROADWAY	CULVERT	BRIDGE REHAB	BRIDGE REHAB	NOISE ABATEMENT WALLS ①	SAFETY	SAFETY
				90% FED		90% FED	90% FED	90% FED	90% FED	90% FED	90% FED
				10% STATE	100% STATE	10% STATE	10% STATE	10% STATE	10% STATE	10% STATE	100% STATE
				URBAN							
				0003	0003	0004	0013	0013	0020	0021	0021
				RURAL	RURAL	099-0760	099-0301	099-0302	RURAL	LIGHTING	LIGHTING
* 20100110	TREE REMOVAL (6 TO 15 UNITS DIAMETER)	UNIT	580	580							
* 20100210	TREE REMOVAL (OVER 15 UNITS DIAMETER)	UNIT	481	481							
* 20100500	TREE REMOVAL, ACRES	ACRE	7.25	7.25							
20101000	TEMPORARY FENCE	FOOT	3,814	3,814							
* 20101100	TREE TRUNK PROTECTION	EACH	8	8							
* 20101200	TREE ROOT PRUNING	EACH	8	8							
* 20101300	TREE PRUNING (1 TO 10 INCH DIAMETER)	EACH	32	32							
* 20101350	TREE PRUNING (OVER 10 INCH DIAMETER)	EACH	63	63							
20200100	EARTH EXCAVATION	CU YD	114,135	114,135							
20200200	ROCK EXCAVATION	CU YD	205	5						200	
20201200	REMOVAL AND DISPOSAL OF UNSUITABLE MATERIAL	CU YD	12,582	12,582							
20400800	FURNISHED EXCAVATION	CU YD	15,410	15,410							
20700220	POROUS GRANULAR EMBANKMENT	CU YD	353			353					
20800150	TRENCH BACKFILL	CU YD	19,672.0	19,672.0							
21001000	GEOTECHNICAL FABRIC FOR GROUND STABILIZATION	SQ YD	35,644	35,153		491					
21101505	TOPSOIL EXCAVATION AND PLACEMENT	CU YD	37,435	37,435							
21101615	TOPSOIL FURNISH AND PLACE, 4"	SQ YD	39,477	39,477							
21101805	COMPOST FURNISH AND PLACE, 2"	SQ YD	1,349	1,349							
* 25000115	SEEDING, CLASS 1B	ACRE	1.25	1.25							
* 25000210	SEEDING, CLASS 2A	ACRE	12.50	12.50							
* 25000310	SEEDING, CLASS 4	ACRE	13.25	13.25							

\* DENOTES SPECIALTY ITEM

① SN 099-N1009, SN 099-N1010, SN 099-N1011, SN 099-N1012, SN 099-N1013, SN 099-N1014 & SN 099-N1015

**TRANSYSTEMS**

USER NAME = amkluver	DESIGNED - VLJ	REVISED -
PLOT SCALE = 0.16666633 1/ in.	DRAWN - AMK	REVISED -
PLOT DATE = 8/18/2023	CHECKED - JMG	REVISED -
	DATE - 6/26/23	REVISED -

**STATE OF ILLINOIS  
DEPARTMENT OF TRANSPORTATION**

**SUMMARY OF QUANTITIES**

SCALE: NONE SHEET 1 OF 16 SHEETS STA. TO STA.

F.A.I. RTE.	SECTION	COUNTY	TOTAL SHEETS	SHEET NO.
I-80	FAI 80 21 STRUCTURE 6	WILL	898	5
			CONTRACT NO. 62R27	
			ILLINOIS FED. AID PROJECT	

MODEL: S00-Q2  
 FILE NAME: p:\transys\transys\comp\pw\_bentley.com\transys\comp\pw\_bentled\Documents\Projects\_2018\CH401\401180022\02-TransSystems\CAD\02R27\02R27\03-SCheck\03-SCheck.dwg\01E2R27-SHT-S00.dgn

CODE NUMBER	PAY ITEM	UNIT	TOTAL QUANTITY	ROADWAY	ROADWAY	CULVERT	BRIDGE REHAB	BRIDGE REHAB	NOISE ABATEMENT WALLS ①	SAFETY	SAFETY
				90% FED		90% FED	90% FED	90% FED	90% FED	90% FED	90% FED
				10% STATE	100% STATE	10% STATE	10% STATE	10% STATE	10% STATE	10% STATE	100% STATE
				0003	0003	0004	0013	0013	0020	0021	0021
				RURAL	RURAL	099-0760	099-0301	099-0302	RURAL	LIGHTING	LIGHTING
* 25000314	SEEDING, CLASS 4B	ACRE	5.50	5.50							
* 25000400	NITROGEN FERTILIZER NUTRIENT	POUND	1,244	1,244							
* 25000600	POTASSIUM FERTILIZER NUTRIENT	POUND	1,244	1,244							
* 25100115	MULCH, METHOD 2	ACRE	22.00	22.00							
* 25100630	EROSION CONTROL BLANKET	SQ YD	125,753	125,753							
25200200	SUPPLEMENTAL WATERING	UNIT	0.7	0.7							
28000200	EARTH EXCAVATION FOR EROSION CONTROL	CU YD	100								
28000250	TEMPORARY EROSION CONTROL SEEDING	POUND	337,640	337,640							
28000305	TEMPORARY DITCH CHECKS	FOOT	445	445							
* 28000400	PERIMETER EROSION BARRIER	FOOT	10,322	10,322							
* 28000510	INLET FILTERS	EACH	193	193							
28001000	AGGREGATE (EROSION CONTROL)	TON	60	60							
28001100	TEMPORARY EROSION CONTROL BLANKET	SQ YD	209,511	209,511							
28001200	TEMPORARY HEAVY DUTY EROSION CONTROL BLANKET	SQ YD	4,238	4,238							
28100105	STONE RIPRAP, CLASS A3	SQ YD	246	246							
28100107	STONE RIPRAP, CLASS A4	SQ YD	376	376							
* 28200200	FILTER FABRIC	SQ YD	992	992							
30300001	AGGREGATE SUBGRADE IMPROVEMENT	CU YD	12,582	12,582							
30300112	AGGREGATE SUBGRADE IMPROVEMENT 12"	SQ YD	171,226	171,226							
31101100	SUBBASE GRANULAR MATERIAL, TYPE B	CU YD	200							200	
31101200	SUBBASE GRANULAR MATERIAL, TYPE B 4"	SQ YD	2,024	2,024							

\* DENOTES SPECIALTY ITEM

① SN 099-N1009, SN 099-N1010, SN 099-N1011, SN 099-N1012, SN 099-N1013, SN 099-N1014 & SN 099-N1015

**TRANSYSTEMS**

USER NAME = amkluver  
 PLOT SCALE = 0.16666633 1/ in.  
 PLOT DATE = 8/18/2023

DESIGNED - VLJ  
 DRAWN - AMK  
 CHECKED - JMG  
 DATE - 6/26/23

REVISED -  
 REVISED -  
 REVISED -  
 REVISED -

**STATE OF ILLINOIS  
DEPARTMENT OF TRANSPORTATION**

**SUMMARY OF QUANTITIES**

SCALE: NONE SHEET 2 OF 16 SHEETS STA. TO STA.

F.A.I. RTE.	SECTION	COUNTY	TOTAL SHEETS	SHEET NO.
I-80	FAI 80 21 STRUCTURE 6	WILL	898	6
CONTRACT NO. 62R27			ILLINOIS FED. AID PROJECT	

MODEL: S00-03  
 FILE NAME: p:\transys\transys\comp\pw\_bentby.com\transys\comp\pw\_bentby.com\Documents\Projects\_2018\CH401\401180022\02-TransSystems\CAD\02R27\02R27\03-Schedule\03-Schedule.dwg

CODE NUMBER	PAY ITEM	UNIT	TOTAL QUANTITY	ROADWAY	ROADWAY	CULVERT	BRIDGE REHAB	BRIDGE REHAB	NOISE ABATEMENT WALLS ①	SAFETY	SAFETY
				90% FED		90% FED	90% FED	90% FED	90% FED	90% FED	90% FED
				10% STATE	100% STATE	10% STATE	10% STATE	10% STATE	10% STATE	10% STATE	100% STATE
				0003	0003	0004	0013	0013	0020	0021	0021
				RURAL	RURAL	099-0760	099-0301	099-0302	RURAL	LIGHTING	LIGHTING
31101600	SUBBASE GRANULAR MATERIAL, TYPE B 8"	SQ YD	38,495	38,495							
31102100	SUBBASE GRANULAR MATERIAL, TYPE C 4"	SQ YD	29,752	29,752							
31200500	STABILIZED SUBBASE - HOT-MIX ASPHALT, 4"	SQ YD	136,531	136,531							
35101800	AGGREGATE BASE COURSE, TYPE B 6"	SQ YD	718	718							
40600290	BITUMINOUS MATERIALS (TACK COAT)	POUND	11,659	11,659							
40604062	HOT-MIX ASPHALT SURFACE COURSE, IL-9.5, MIX "D", N70	TON	4,643	4,643							
42000080	PAVEMENT CONNECTOR (PCC) FOR BRIDGE APPROACH SLAB	SQ YD	310	310							
42000531	PORTLAND CEMENT CONCRETE PAVEMENT 11 ½" (JOINTED)	SQ YD	7,924	7,924							
42001300	PROTECTIVE COAT	SQ YD	176,014	176,014							
42100360	CONTINUOUSLY REINFORCED PORTLAND CEMENT CONCRETE PAVEMENT 13"	SQ YD	95,891	95,891							
42100615	PAVEMENT REINFORCEMENT	SQ YD	95,891	95,891							
42101436	LUG SYSTEM COMPLETE 36'	EACH	6	6							
44000100	PAVEMENT REMOVAL	SQ YD	123,398	123,398							
44000157	HOT-MIX ASPHALT SURFACE REMOVAL, 2"	SQ YD	16,875	16,875							
44004000	PAVED DITCH REMOVAL	FOOT	14	14							
44004250	PAVED SHOULDER REMOVAL	SQ YD	37,672	37,672							
44201794	CLASS D PATCHES, TYPE III, 12 INCH	SQ YD	144	144							
48101500	AGGREGATE SHOULDERS, TYPE B 6"	SQ YD	8,262	8,262							
48300610	PORTLAND CEMENT CONCRETE SHOULDERS 11 ½"	SQ YD	5,969	5,969							
48300800	PORTLAND CEMENT CONCRETE SHOULDERS 13"	SQ YD	53,752	53,752							
50100100	REMOVAL OF EXISTING STRUCTURES	EACH	1			1					

\* DENOTES SPECIALTY ITEM

① SN 099-N1009, SN 099-N1010, SN 099-N1011, SN 099-N1012, SN 099-N1013, SN 099-N1014 & SN 099-N1015



USER NAME = amkluver	DESIGNED - VLJ	REVISED -
PLOT SCALE = 0.16666633 1/ in.	DRAWN - AMK	REVISED -
PLOT DATE = 8/18/2023	CHECKED - JMG	REVISED -
	DATE - 6/26/23	REVISED -

**STATE OF ILLINOIS  
DEPARTMENT OF TRANSPORTATION**

**SUMMARY OF QUANTITIES**

SCALE: NONE SHEET 3 OF 16 SHEETS STA. TO STA.

F.A.I. RTE.	SECTION	COUNTY	TOTAL SHEETS	SHEET NO.
I-80	FAI 80 21 STRUCTURE 6	WILL	898	7
			CONTRACT NO. 62R27	
		ILLINOIS	FED. AID PROJECT	



MODEL: S00-04  
FILE NAME: p:\transystems\pw\_bentley.com\transyscorp\pw\_1\hosted\Documents\Projects\_2018\CH40118002202-TransSystems\CAD\2R27\Sheets\03-Schedule\01E2R27-SHT-S00.dgn

CODE NUMBER	PAY ITEM	UNIT	TOTAL QUANTITY	ROADWAY	ROADWAY	CULVERT	BRIDGE REHAB	BRIDGE REHAB	NOISE ABATEMENT WALLS ①	SAFETY	SAFETY
				90% FED		90% FED	90% FED	90% FED	90% FED	90% FED	90% FED
				10% STATE	100% STATE	10% STATE	10% STATE	10% STATE	10% STATE	10% STATE	100% STATE
				0003	0003	0004	0013	0013	0020	0021	0021
			URBAN	RURAL	RURAL	099-0760	099-0301	099-0302	RURAL	LIGHTING	LIGHTING
50102400	CONCRETE REMOVAL	CU YD	130.5				65.3	65.2			
50104650	SLOPE WALL REMOVAL	SQ YD	252				127	125			
50104701	REMOVAL OF EXISTING CONCRETE DECK NO. 1	EACH	1				1				
50104702	REMOVAL OF EXISTING CONCRETE DECK NO. 2	EACH	1					1			
50157300	PROTECTIVE SHIELD	SQ YD	1,201				638	563			
50105220	PIPE CULVERT REMOVAL	FOOT	152	152							
50200100	STRUCTURE EXCAVATION	CU YD	3,345.6			2,646	350.2	349.4			
50200400	ROCK EXCAVATION FOR STRUCTURES	CU YD	115	107						8	
50200450	REMOVAL AND DISPOSAL OF UNSUITABLE MATERIAL FOR STRUCTURES	CU YD	203			203					
50300100	FLOOR DRAINS	EACH	4				2	2			
50300225	CONCRETE STRUCTURES	CU YD	166.7				79.6	87.1			
50300255	CONCRETE SUPERSTRUCTURE	CU YD	1,408.2	471.9			488.6	447.7			
50300300	PROTECTIVE COAT	SQ YD	3,902	357			1,797	1,748			
50301350	CONCRETE SUPERSTRUCTURE (APPROACH SLAB)	CU YD	390.4				195.2	195.2			
50500105	FURNISHING AND ERECTING STRUCTURAL STEEL	L SUM	1.0				0.5	0.5			
50500505	STUD SHEAR CONNECTORS	EACH	1,920				960	960			
50800105	REINFORCEMENT BARS	POUND	103,010			103,010					
50800205	REINFORCEMENT BARS, EPOXY COATED	POUND	456,170	111,040			174,600	170,530			
50800515	BAR SPLICERS	EACH	2,552			296	1,128	1,128			
50800530	MECHANICAL SPLICERS	EACH	48				24	24			
51100100	SLOPE WALL 4 INCH	SQ YD	222				111	111			

\* DENOTES SPECIALTY ITEM

① SN 099-N1009, SN 099-N1010, SN 099-N1011, SN 099-N1012, SN 099-N1013, SN 099-N1014 & SN 099-N1015



USER NAME = amkluver	DESIGNED - VLJ	REVISED -
PLOT SCALE = 0.16666633 ' / in.	DRAWN - AMK	REVISED -
PLOT DATE = 8/18/2023	CHECKED - JMG	REVISED -
	DATE - 6/26/23	REVISED -

**STATE OF ILLINOIS  
DEPARTMENT OF TRANSPORTATION**

**SUMMARY OF QUANTITIES**

SCALE: NONE SHEET 4 OF 16 SHEETS STA. TO STA.

F.A.I. RTE.	SECTION	COUNTY	TOTAL SHEETS	SHEET NO.
I-80	FAI 80 21 STRUCTURE 6	WILL	898	8
			CONTRACT NO. 62R27	
		ILLINOIS	FED. AID PROJECT	

MODEL: SDO-05  
 FILE NAME: p:\trnsys\transyscomp\p\4-bested\Documents\Projects\_2018\CI-401\401180022\02-TransSystems\CAD\2R27\Sheet\03-Schedule\03-Schedule.dwg

CODE NUMBER	PAY ITEM	UNIT	TOTAL QUANTITY	ROADWAY	ROADWAY	CULVERT	BRIDGE REHAB	BRIDGE REHAB	NOISE ABATEMENT WALLS ①	SAFETY	SAFETY
				90% FED	100% STATE	90% FED	90% FED	90% FED	90% FED	90% FED	90% FED
				10% STATE	100% STATE	10% STATE	10% STATE	10% STATE	10% STATE	10% STATE	100% STATE
				0003	0003	0004	0013	0013	0020	0021	
	RURAL	RURAL	099-0760	099-0301	099-0302	RURAL	LIGHTING	LIGHTING			
* 51201800	FURNISHING STEEL PILES HP14X73	FOOT	962				485	477			
* 51202305	DRIVING PILES	FOOT	962				485	477			
* 51203800	TEST PILE STEEL HP14X73	EACH	2				1	1			
* 51204650	PILE SHOES	EACH	28				14	14			
* 51500100	NAME PLATES	EACH	10			1	1	1	7		
52000040	PREFORMED JOINT SEAL 3 1/2"	FOOT	210.0				210.0				
52100520	ANCHOR BOLTS, 1"	EACH	32				16	16			
52200020	TEMPORARY SOIL RETENTION SYSTEM	SQ FT	3,806			3,066	364	376			
54003000	CONCRETE BOX CULVERTS	CU YD	415			415					
54213657	PRECAST REINFORCED CONCRETE FLARED END SECTIONS 12"	EACH	13	13							
54213660	PRECAST REINFORCED CONCRETE FLARED END SECTIONS 15"	EACH	4	4							
54213663	PRECAST REINFORCED CONCRETE FLARED END SECTIONS 18"	EACH	1	1							
54213669	PRECAST REINFORCED CONCRETE FLARED END SECTIONS 24"	EACH	3	3							
54213675	PRECAST REINFORCED CONCRETE FLARED END SECTIONS 30"	EACH	1	1							
54213681	PRECAST REINFORCED CONCRETE FLARED END SECTIONS 36"	EACH	7	7							
5422D012	PIPE CULVERTS, CLASS D, TYPE 2 12" (TEMPORARY)	FOOT	798	798							
5422D024	PIPE CULVERTS, CLASS D, TYPE 2 24" (TEMPORARY)	FOOT	20	20							
5422D030	PIPE CULVERTS, CLASS D, TYPE 2 30" (TEMPORARY)	FOOT	14	14							
542A1069	PIPE CULVERTS, CLASS A, TYPE 2 24"	FOOT	184	184							
550A0050	STORM SEWERS, CLASS A, TYPE 1 12"	FOOT	135	135							
550A0070	STORM SEWERS, CLASS A, TYPE 1 15"	FOOT	20	20							

\* DENOTES SPECIALTY ITEM

① SN 099-N1009, SN 099-N1010, SN 099-N1011, SN 099-N1012, SN 099-N1013, SN 099-N1014 & SN 099-N1015

USER NAME = amkluver	DESIGNED - VLJ	REVISED -
	DRAWN - AMK	REVISED -
PLOT SCALE = 0.16666633 ' / in.	CHECKED - JMG	REVISED -
PLOT DATE = 8/18/2023	DATE - 6/26/23	REVISED -

**STATE OF ILLINOIS  
DEPARTMENT OF TRANSPORTATION**

**SUMMARY OF QUANTITIES**

SCALE: NONE SHEET 5 OF 16 SHEETS STA. TO STA.

F.A.I. RTE.	SECTION	COUNTY	TOTAL SHEETS	SHEET NO.
I-80	FAI 80 21 STRUCTURE 6	WILL	898	9
CONTRACT NO. 62R27				
ILLINOIS		FED. AID PROJECT		

MODEL: SDO-06  
 FILE NAME: p:\transystems\pw\_bentley.com\transyscorp\pw1\hosted\Documents\Projects\_2018\CH401\401180022\02-TransSystems\CAD\2R27\Sheets\03-Schedule\03ER27-SHT-SDO.dgn

CODE NUMBER	PAY ITEM	UNIT	TOTAL QUANTITY	ROADWAY	ROADWAY	CULVERT	BRIDGE REHAB	BRIDGE REHAB	NOISE ABATEMENT WALLS ①	SAFETY	SAFETY
				90% FED		90% FED	90% FED	90% FED	90% FED	90% FED	90% FED
				10% STATE	100% STATE	10% STATE	10% STATE	10% STATE	10% STATE	10% STATE	100% STATE
				0003	0003	0004	0013	0013	0020	0021	0021
				RURAL	RURAL	099-0760	099-0301	099-0302	RURAL	LIGHTING	LIGHTING
550A0090	STORM SEWERS, CLASS A, TYPE 1 18"	FOOT	442	442							
550A0110	STORM SEWERS, CLASS A, TYPE 1 21"	FOOT	126	126							
550A0120	STORM SEWERS, CLASS A, TYPE 1 24"	FOOT	240	240							
550A0140	STORM SEWERS, CLASS A, TYPE 1 30"	FOOT	1,251	1,251							
550A0160	STORM SEWERS, CLASS A, TYPE 1 36"	FOOT	2,139	2,139							
550A0180	STORM SEWERS, CLASS A, TYPE 1 42"	FOOT	96	96							
550A0340	STORM SEWERS, CLASS A, TYPE 2 12"	FOOT	88	88							
550A0360	STORM SEWERS, CLASS A, TYPE 2 15"	FOOT	1,541	1,541							
550A0380	STORM SEWERS, CLASS A, TYPE 2 18"	FOOT	1,410	1,410							
550A0410	STORM SEWERS, CLASS A, TYPE 2 24"	FOOT	1,189	1,189							
550A0430	STORM SEWERS, CLASS A, TYPE 2 30"	FOOT	660	660							
550A0450	STORM SEWERS, CLASS A, TYPE 2 36"	FOOT	3,457	3,457							
550A0680	STORM SEWERS, CLASS A, TYPE 3 18"	FOOT	96	96							
55101600	STORM SEWER REMOVAL 36"	FOOT	400	400							
55200900	STORM SEWERS JACKED IN PLACE, 24"	FOOT	77	77							
55201100	STORM SEWERS JACKED IN PLACE, 30"	FOOT	386	386							
55201300	STORM SEWERS JACKED IN PLACE, 36"	FOOT	476	476							
55201500	STORM SEWERS JACKED IN PLACE, 42"	FOOT	93	93							
58600101	GRANULAR BACKFILL FOR STRUCTURES	CU YD	1,059.9			203	418	438.9			
59100100	GEOCOMPOSITE WALL DRAIN	SQ YD	2,247			624	173	177	1,273		
60100060	CONCRETE HEADWALLS FOR PIPE DRAINS	EACH	32	28			2	2			

\* DENOTES SPECIALTY ITEM

① SN 099-N1009, SN 099-N1010, SN 099-N1011, SN 099-N1012, SN 099-N1013, SN 099-N1014 & SN 099-N1015



USER NAME = amkluver	DESIGNED - VLJ	REVISED -
PLOT SCALE = 0.16666633 1/ in.	DRAWN - AMK	REVISED -
PLOT DATE = 8/18/2023	CHECKED - JMG	REVISED -
	DATE - 6/26/23	REVISED -

**STATE OF ILLINOIS  
DEPARTMENT OF TRANSPORTATION**

**SUMMARY OF QUANTITIES**

SCALE: NONE SHEET 6 OF 16 SHEETS STA. TO STA.

F.A.I. RTE.	SECTION	COUNTY	TOTAL SHEETS	SHEET NO.
I-80	FAI 80 21 STRUCTURE 6	WILL	898	10
			CONTRACT NO. 62R27	
		ILLINOIS	FED. AID PROJECT	

MODEL: S00-07  
 FILE NAME: p:\transys\transyscomp\pw-j\hosed\Documents\Projects\_2018\CH-401180022\02-Trans\Systems\CAD\62R27\Sheet\03-Systems\03-Sched\62R27-SHT-S00.dgn

CODE NUMBER	PAY ITEM	UNIT	TOTAL QUANTITY	ROADWAY	ROADWAY	CULVERT	BRIDGE REHAB	BRIDGE REHAB	NOISE ABATEMENT WALLS (1)	SAFETY	SAFETY
				90% FED	100% STATE	90% FED	90% FED	90% FED	90% FED	90% FED	90% FED
				10% STATE	100% STATE	10% STATE	10% STATE	10% STATE	10% STATE	10% STATE	100% STATE
				0003	0003	0004	0013	0013	0020	0021	0021
				RURAL	RURAL	099-0760	099-0301	099-0302	RURAL	LIGHTING	LIGHTING
60108200	PIPE UNDERDRAINS 6" (SPECIAL)	FOOT	874	874							
60108206	PIPE UNDERDRAINS, TYPE 2, 6"	FOOT	35,480	35,480							
60146304	PIPE UNDERDRAINS FOR STRUCTURES 4"	FOOT	6,426			173	171	6,082			
60146305	PIPE UNDERDRAINS FOR STRUCTURES (SPECIAL) 4"	FOOT	160			80	80				
60201310	CATCH BASINS, TYPE A, 4'-DIAMETER, TYPE 20 FRAME AND GRATE	EACH	100	100							
60205010	CATCH BASINS, TYPE A, 5'-DIAMETER, TYPE 20 FRAME AND GRATE	EACH	50	50							
60206600	CATCH BASINS, TYPE B, TYPE 7 GRATE	EACH	1	1							
60218400	MANHOLES, TYPE A, 4'-DIAMETER, TYPE 1 FRAME, CLOSED LID	EACH	1	1							
60219000	MANHOLES, TYPE A, 4'-DIAMETER, TYPE 8 GRATE	EACH	8	8							
60221100	MANHOLES, TYPE A, 5'-DIAMETER, TYPE 1 FRAME, CLOSED LID	EACH	1	1							
60224035	MANHOLES, TYPE A, 6'-DIAMETER, TYPE 20 FRAME AND GRATE	EACH	6	6							
60224440	MANHOLES, TYPE A, 7'-DIAMETER, TYPE 20 FRAME AND GRATE	EACH	5	5							
60224464	MANHOLES, TYPE A, 8'-DIAMETER, TYPE 20 FRAME AND GRATE	EACH	1	1							
60236200	INLETS, TYPE A, TYPE 8 GRATE	EACH	13	13							
60237420	INLETS, TYPE A, TYPE 20 FRAME AND GRATE	EACH	4	4							
60605000	COMBINATION CONCRETE CURB AND GUTTER, TYPE B-6,24	FOOT	784	784							
60602800	CONCRETE GUTTER, TYPE B	FOOT	4,991	4,991							
60618300	CONCRETE MEDIAN SURFACE, 4 INCH	SQ FT	718	718							
60623200	CONCRETE MEDIAN, TYPE SM-6,24	SQ FT	108	108							
60920036	PIPE CULVERTS TO BE CLEANED 36"	FOOT	262		262						
* 63000001	STEEL PLATE BEAM GUARDRAIL, TYPE A, 6 FOOT POSTS	FOOT	5,153	5,153							

\* DENOTES SPECIALTY ITEM

(1) SN 099-N1009, SN 099-N1010, SN 099-N1011, SN 099-N1012, SN 099-N1013, SN 099-N1014 & SN 099-N1015



USER NAME = amkluver	DESIGNED - VLJ	REVISED -
PLOT SCALE = 0.16666633 '"/>		

DRAWN - AMK	REVISED -
CHECKED - JMG	REVISED -
DATE - 6/26/23	REVISED -

**STATE OF ILLINOIS  
DEPARTMENT OF TRANSPORTATION**

**SUMMARY OF QUANTITIES**

SCALE: NONE SHEET 7 OF 16 SHEETS STA. TO STA.

F.A.I. RTE.	SECTION	COUNTY	TOTAL SHEETS	SHEET NO.
I-80	FAI 80 21 STRUCTURE 6	WILL	898	11
			CONTRACT NO. 62R27	
		ILLINOIS	FED. AID PROJECT	

MODEL: S00-08  
 FILE NAME: p:\transys\transys\comp\pw-j\hosted\Documents\Projects\_2018\CH401401180022\02-TransSystems\CAD\02R27\Sheet\03-Schedule\03-000.dgn

CODE NUMBER	PAY ITEM	UNIT	TOTAL QUANTITY	ROADWAY	ROADWAY	CULVERT	BRIDGE REHAB	BRIDGE REHAB	NOISE ABATEMENT WALLS ①	SAFETY	SAFETY
				90% FED		90% FED	90% FED	90% FED	90% FED	90% FED	90% FED
				10% STATE	100% STATE	10% STATE	10% STATE	10% STATE	10% STATE	10% STATE	100% STATE
				0003	0003	0004	0013	0013	0020	0021	0021
			URBAN	RURAL	RURAL	099-0760	099-0301	099-0302	RURAL	LIGHTING	LIGHTING
* 63100045	TRAFFIC BARRIER TERMINAL, TYPE 2	EACH	6	6							
* 63100070	TRAFFIC BARRIER TERMINAL, TYPE 5	EACH	2	2							
* 63100085	TRAFFIC BARRIER TERMINAL, TYPE 6	EACH	5	5							
* 63100167	TRAFFIC BARRIER TERMINAL, TYPE 1 (SPECIAL) TANGENT	EACH	8	8							
63200310	GUARDRAIL REMOVAL	FOOT	6,884	6,884							
63201100	HIGH TENSION CABLE MEDIAN BARRIER REMOVAL	FOOT	8,966	8,966							
63500105	DELINEATORS	EACH	89	89							
63700180	CONCRETE BARRIER, SINGLE FACE, 44 INCH HEIGHT	FOOT	1,050	1,050							
63700280	CONCRETE BARRIER, DOUBLE FACE, 44 INCH HEIGHT	FOOT	8,977	8,977							
63700380	CONCRETE BARRIER, VARIABLE CROSS SECTION 44 INCH HEIGHT	FOOT	781	781							
63700900	CONCRETE BARRIER BASE	FOOT	8,977	8,977							
63800920	MODULAR GLARE SCREEN SYSTEM, TEMPORARY	FOOT	700	700							
64200116	SHOULDER RUMBLE STRIPS, 16 INCH	FOOT	38,881	38,881							
64401300	HIGH TENSION CABLE MEDIAN BARRIER TERMINALS	EACH	3	3							
66400105	CHAIN LINK FENCE, 4'	FOOT	15,703	15,703							
66400705	CHAIN LINK GATES, 4' X 4' SINGLE	EACH	5	5							
67100100	MOBILIZATION	L SUM	1	1							
70103815	TRAFFIC CONTROL SURVEILLANCE	CAL DA	90	90							
70107025	CHANGEABLE MESSAGE SIGN	CAL DA	4,320	4,320							
70301100	TEMPORARY PAVEMENT MARKING LETTERS AND SYMBOLS - EPOXY	SQ FT	500	500							
70301120	TEMPORARY PAVEMENT MARKING - LINE 4" - EPOXY	FOOT	429,464	429,464							

\* DENOTES SPECIALTY ITEM

① SN 099-N1009, SN 099-N1010, SN 099-N1011, SN 099-N1012, SN 099-N1013, SN 099-N1014 & SN 099-N1015



USER NAME = amkluver	DESIGNED - VLJ	REVISED -
PLOT SCALE = 0.16666633 1/16 in.	DRAWN - AMK	REVISED -
PLOT DATE = 8/18/2023	CHECKED - JMG	REVISED -
	DATE - 6/26/23	REVISED -

**STATE OF ILLINOIS  
DEPARTMENT OF TRANSPORTATION**

**SUMMARY OF QUANTITIES**

SCALE: NONE SHEET 8 OF 16 SHEETS STA. TO STA.

F.A.I. RTE.	SECTION	COUNTY	TOTAL SHEETS	SHEET NO.
I-80	FAI 80 21 STRUCTURE 6	WILL	898	12
			CONTRACT NO. 62R27	
		ILLINOIS	FED. AID PROJECT	



MODEL: SDO-06  
 FILE NAME: p:\transys\transys\comp\pw\_1\res\res\Documents\Projects\_2018\CH401\401180022\02-TransSystems\CAD\62R27\62R27\62R27-SHT-SOO.dgn

CODE NUMBER	PAY ITEM	UNIT	TOTAL QUANTITY	ROADWAY	ROADWAY	CULVERT	BRIDGE REHAB	BRIDGE REHAB	NOISE ABATEMENT WALLS ①	SAFETY	SAFETY
				90% FED		90% FED	90% FED	90% FED	90% FED	90% FED	90% FED
				10% STATE	100% STATE	10% STATE	10% STATE	10% STATE	10% STATE	10% STATE	100% STATE
				URBAN							
				0003	0003	0004	0013	0013	0020	0021	0021
				RURAL	RURAL	099-0760	099-0301	099-0302	RURAL	LIGHTING	LIGHTING
70301125	TEMPORARY PAVEMENT MARKING - LINE 5" - EPOXY	FOOT	44,417	44,417							
70301130	TEMPORARY PAVEMENT MARKING - LINE 6" - EPOXY	FOOT	46,313	46,313							
70301140	TEMPORARY PAVEMENT MARKING - LINE 8" - EPOXY	FOOT	70,379	70,379							
70301160	TEMPORARY PAVEMENT MARKING - LINE 12" - EPOXY	FOOT	4,813	4,813							
70400100	TEMPORARY CONCRETE BARRIER	FOOT	46,312.5	46,312.5							
70400125	PINNING TEMPORARY CONCRETE BARRIER	EACH	13,347	13,347							
70400200	RELOCATE TEMPORARY CONCRETE BARRIER	FOOT	128,687.5	128,687.5							
70600280	IMPACT ATTENUATORS, TEMPORARY (SEVERE USE,NARROW), TEST LEVEL 3	EACH	15	15							
70600290	IMPACT ATTENUATORS, TEMPORARY (SEVERE USE,WIDE), TEST LEVEL 3	EACH	2	2							
70600360	IMPACT ATTENUATORS, RELOCATE (SEVERE USE), TEST LEVEL 3	EACH	2	2							
70600370	IMPACT ATTENUATORS, RELOCATE (SEVERE USE, NARROW), TEST LEVEL 3	EACH	61	61							
* 72000100	SIGN PANEL - TYPE 1	SQ FT	91	91							
* 72000200	SIGN PANEL - TYPE 2	SQ FT	364	364							
* 72000300	SIGN PANEL - TYPE 3	SQ FT	3,713	3,713							
* 72400310	REMOVE SIGN PANEL - TYPE 1	SQ FT	76	76							
* 72400320	REMOVE SIGN PANEL - TYPE 2	SQ FT	170	170							
* 72400330	REMOVE SIGN PANEL - TYPE 3	SQ FT	1,709	1,709							
* 72400500	RELOCATE SIGN PANEL ASSEMBLY - TYPE A	EACH	2	2							
* 72400710	RELOCATE SIGN PANEL - TYPE 1	SQ FT	33	33							
* 72400730	RELOCATE SIGN PANEL - TYPE 3	SQ FT	300	300							
* 72501000	TERMINAL MARKER - DIRECT APPLIED	EACH	8	8							

\* DENOTES SPECIALTY ITEM

① SN 099-N1009, SN 099-N1010, SN 099-N1011, SN 099-N1012, SN 099-N1013, SN 099-N1014 & SN 099-N1015



USER NAME = amkluver	DESIGNED - VLJ	REVISED -
PLOT SCALE = 0.16666633 1/ in.	DRAWN - AMK	REVISED -
PLOT DATE = 8/18/2023	CHECKED - JMG	REVISED -
	DATE - 6/26/23	REVISED -

**STATE OF ILLINOIS  
DEPARTMENT OF TRANSPORTATION**

**SUMMARY OF QUANTITIES**

SCALE: NONE SHEET 9 OF 16 SHEETS STA. TO STA.

F.A.I. RTE.	SECTION	COUNTY	TOTAL SHEETS	SHEET NO.
I-80	FAI 80 21 STRUCTURE 6	WILL	898	13
			CONTRACT NO. 62R27	
		ILLINOIS	FED. AID PROJECT	

MODEL: S00-10  
FILE NAME: p:\transystems\pwp\transystems\pwp\checked\Documents\Projects\_2018\CH401401180022\02-TransSystems\CAD\02R27\02R27\03-Structure\03-Structure.dwg\02R27-SHT-S00.dgn

CODE NUMBER	PAY ITEM	UNIT	TOTAL QUANTITY	ROADWAY	ROADWAY	CULVERT	BRIDGE REHAB	BRIDGE REHAB	NOISE ABATEMENT WALLS ①	SAFETY	SAFETY
				90% FED	100% STATE	90% FED	90% FED	90% FED	90% FED	90% FED	90% FED
				10% STATE	100% STATE	10% STATE	10% STATE	10% STATE	10% STATE	10% STATE	100% STATE
				0003	0003	0004	0013	0013	0020	0021	0021
				RURAL	RURAL	099-0760	099-0301	099-0302	RURAL	LIGHTING	LIGHTING
* 72600100	MILE POST MARKER ASSEMBLY	EACH	8	8							
* 72700100	STRUCTURAL STEEL SIGN SUPPORT - BREAKAWAY	POUND	20,580	20,580							
* 72800100	TELESCOPING STEEL SIGN SUPPORT	FOOT	226	226							
* 73000100	WOOD SIGN SUPPORT	FOOT	613	613							
* 73300100	OVERHEAD SIGN STRUCTURE - SPAN, TYPE I-A (4'-0" X 4'-6")	FOOT	83	83							
* 73300200	OVERHEAD SIGN STRUCTURE - SPAN, TYPE II-A (4'-6" X 5'-3")	FOOT	88	88							
* 73300300	OVERHEAD SIGN STRUCTURE - SPAN, TYPE III-A (5'-0" X 7'-0")	FOOT	85	85							
* 73301810	OVERHEAD SIGN STRUCTURE WALKWAY, TYPE A	FOOT	52	52							
* 73302210	OVERHEAD SIGN STRUCTURE - CANTILEVER, TYPE III-C-A (36" X 7'-0")	FOOT	65	65							
* 73400100	CONCRETE FOUNDATIONS	CU YD	53	53							
* 73400200	DRILLED SHAFT CONCRETE FOUNDATIONS	CU YD	104	104							
* 73500010	REMOVE OVERHEAD SIGN STRUCTURE - CANTILEVER	EACH	1	1							
* 73600100	REMOVE OVERHEAD SIGN STRUCTURE - SPAN	EACH	3	3							
* 73700100	REMOVE GROUND MOUNTED SIGN SUPPORT	EACH	42	42							
* 73700200	REMOVE CONCRETE FOUNDATION - GROUND MOUNT	EACH	42	42							
* 73700300	REMOVE CONCRETE FOUNDATION - OVERHEAD	EACH	9	9							
* 78004630	PREFORMED PLASTIC PAVEMENT MARKING, TYPE D - STANDARD - LINE 6"	FOOT	14,199	14,199							
* 78004635	PREFORMED PLASTIC PAVEMENT MARKING, TYPE D - STANDARD - LINE 7"	FOOT	818	818							
* 78004640	PREFORMED PLASTIC PAVEMENT MARKING, TYPE D - STANDARD - LINE 8"	FOOT	10,384	10,384							
* 78004645	PREFORMED PLASTIC PAVEMENT MARKING, TYPE D - STANDARD - LINE 9"	FOOT	5,460	5,460							
* 78004655	PREFORMED PLASTIC PAVEMENT MARKING, TYPE D - STANDARD - LINE 11"	FOOT	831	831							

\* DENOTES SPECIALTY ITEM

① SN 099-N1009, SN 099-N1010, SN 099-N1011, SN 099-N1012, SN 099-N1013, SN 099-N1014 & SN 099-N1015

**TRANSYSTEMS**

USER NAME = amkluver	DESIGNED - VLJ	REVISED -
PLOT SCALE = 0.16666633 1/ in.	DRAWN - AMK	REVISED -
PLOT DATE = 8/18/2023	CHECKED - JMG	REVISED -
	DATE - 6/26/23	REVISED -

**STATE OF ILLINOIS  
DEPARTMENT OF TRANSPORTATION**

**SUMMARY OF QUANTITIES**

SCALE: NONE SHEET 10 OF 16 SHEETS STA. TO STA.

F.A.I. RTE.	SECTION	COUNTY	TOTAL SHEETS	SHEET NO.
I-80	FAI 80 21 STRUCTURE 6	WILL	898	14
ILLINOIS FED. AID PROJECT			CONTRACT NO. 62R27	

MODEL: SPO-11  
 FILE NAME: p:\transystems\ppl\transystems\ppl\hosted\Documents\Projects\_2018\CH401180022\02-TransSystems\CAD\02R27\02R27\03-Schedule\03-Schedule.dwg/03-Schedule.dwg

CODE NUMBER	PAY ITEM	UNIT	TOTAL QUANTITY	ROADWAY	ROADWAY	CULVERT	BRIDGE REHAB	BRIDGE REHAB	NOISE ABATEMENT WALLS ①	SAFETY	SAFETY
				90% FED	100% STATE	90% FED	90% FED	90% FED	90% FED	90% FED	90% FED
				10% STATE	100% STATE	10% STATE	10% STATE	10% STATE	10% STATE	10% STATE	100% STATE
				0003	0003	0004	0013	0013	0020	0021	0021
				RURAL	RURAL	099-0760	099-0301	099-0302	RURAL	LIGHTING	LIGHTING
* 78009000	MODIFIED URETHANE PAVEMENT MARKING - LETTERS AND SYMBOLS	SQ FT	134	134							
* 78009006	MODIFIED URETHANE PAVEMENT MARKING - LINE 6"	FOOT	24,072	24,072							
* 78009008	MODIFIED URETHANE PAVEMENT MARKING - LINE 8"	FOOT	3,697	3,697							
* 78009012	MODIFIED URETHANE PAVEMENT MARKING - LINE 12"	FOOT	3,766	3,766							
* 78011035	GROOVING FOR RECESSED PAVEMENT MARKING 7"	FOOT	14,199	14,199							
* 78011040	GROOVING FOR RECESSED PAVEMENT MARKING 8"	FOOT	818	818							
* 78011045	GROOVING FOR RECESSED PAVEMENT MARKING 9"	FOOT	10,384	10,384							
* 78011050	GROOVING FOR RECESSED PAVEMENT MARKING 10"	FOOT	5,460	5,460							
* 78011060	GROOVING FOR RECESSED PAVEMENT MARKING 12"	FOOT	831	831							
* 78100100	RAISED REFLECTIVE PAVEMENT MARKER	EACH	731	731							
* 78200005	GUARDRAIL REFLECTORS, TYPE A	EACH	78	78							
* 78200011	BARRIER WALL REFLECTORS, TYPE C	EACH	3,691	3,691							
78300200	RAISED REFLECTIVE PAVEMENT MARKER REMOVAL	EACH	740	740							
78300202	PAVEMENT MARKING REMOVAL - WATER BLASTING	SQ FT	80,023	80,023							
* 80400100	ELECTRIC SERVICE INSTALLATION	EACH	1							1	
* 80400200	ELECTRIC UTILITY SERVICE CONNECTION	L SUM	1							1	
* 81024600	CONDUIT ENCASED, CONCRETE, 6" DIA., PVC 1 WIDE X 1 HIGH	FOOT	50							50	
* 81028200	UNDERGROUND CONDUIT, GALVANIZED STEEL, 2" DIA.	FOOT	608							608	
* 81028240	UNDERGROUND CONDUIT, GALVANIZED STEEL, 4" DIA.	FOOT	1,270							1,065	205
* 81028390	UNDERGROUND CONDUIT, PVC, 4" DIA.	FOOT	330							330	
* 81028750	UNDERGROUND CONDUIT, COILABLE NONMETALLIC CONDUIT, 2" DIA.	FOOT	12,775							12,775	

\* DENOTES SPECIALTY ITEM

① SN 099-N1009, SN 099-N1010, SN 099-N1011, SN 099-N1012, SN 099-N1013, SN 099-N1014 & SN 099-N1015

**TRANSYSTEMS**

USER NAME = amkluver  
 PLOT SCALE = 0.16666633 1/ in.  
 PLOT DATE = 8/18/2023

DESIGNED - VLJ  
 DRAWN - AMK  
 CHECKED - JMG  
 DATE - 6/26/23

REVISED -  
 REVISED -  
 REVISED -  
 REVISED -

**STATE OF ILLINOIS  
DEPARTMENT OF TRANSPORTATION**

**SUMMARY OF QUANTITIES**

SCALE: NONE SHEET 11 OF 16 SHEETS STA. TO STA.

F.A.I. RTE.	SECTION	COUNTY	TOTAL SHEETS	SHEET NO.
I-80	FAI 80 21 STRUCTURE 6	WILL	898	15
CONTRACT NO. 62R27				
ILLINOIS		FED. AID PROJECT		

MODEL: S00-12  
 FILE NAME: p:\transystems\ppl\ben\transystems\ppl\ben\transystems\CAD\62R27\Drawings\03-Structure\03-Structure.dwg\162R27-SHT-S00.dgn

CODE NUMBER	PAY ITEM	UNIT	TOTAL QUANTITY	ROADWAY	ROADWAY	CULVERT	BRIDGE REHAB	BRIDGE REHAB	NOISE ABATEMENT WALLS ①	SAFETY	SAFETY	
				90% FED		90% FED	90% FED	90% FED	90% FED	90% FED	90% FED	
				10% STATE	100% STATE	10% STATE	10% STATE	10% STATE	10% STATE	10% STATE	100% STATE	
				0003	0003	0004	0013	0013	0020	0021		
				RURAL	RURAL	099-0760	099-0301	099-0302	RURAL	LIGHTING	LIGHTING	
* 81100320	CONDUIT ATTACHED TO STRUCTURE, 1" DIA., PVC COATED GALVANIZED STEEL	FOOT	185								185	
* 81200230	CONDUIT EMBEDDED IN STRUCTURE, 2" DIA., PVC	FOOT	230								230	
* 81200270	CONDUIT EMBEDDED IN STRUCTURE, 4" DIA., PVC	FOOT	10,585								10,585	
* 81300220	JUNCTION BOX, STAINLESS STEEL, ATTACHED TO STRUCTURE, 6" X 6" X 4"	EACH	2								2	
* 81300530	JUNCTION BOX, STAINLESS STEEL, ATTACHED TO STRUCTURE, 12" X 10" X 6"	EACH	2								2	
* 81400200	HEAVY-DUTY HANDHOLE	EACH	20								20	
* 81603081	UNIT DUCT, 600V, 3-1C NO.2, 1/C NO.4 GROUND, (XLP-TYPE USE), 1 1/2" DIA. POLYETHYLENE	FOOT	705								705	
* 81603090	UNIT DUCT, 600V, 3-1C NO.4, 1/C NO.6 GROUND, (XLP-TYPE USE), 1 1/4" DIA. POLYETHYLENE	FOOT	7,505								7,505	
* 81702110	ELECTRIC CABLE IN CONDUIT, 600V (XLP-TYPE USE) 1/C NO. 10	FOOT	635								635	
* 81702130	ELECTRIC CABLE IN CONDUIT, 600V (XLP-TYPE USE) 1/C NO. 6	FOOT	3,300								3,300	
* 81702140	ELECTRIC CABLE IN CONDUIT, 600V (XLP-TYPE USE) 1/C NO. 4	FOOT	17,187								17,187	
* 81702150	ELECTRIC CABLE IN CONDUIT, 600V (XLP-TYPE USE) 1/C NO. 2	FOOT	22,086								22,086	
* 82110009	LUMINAIRE, LED, ROADWAY, OUTPUT DESIGNATION I	EACH	110								110	
* 82110026	LUMINAIRE, LED, UNDERPASS, SUSPENDED, OUTPUT DESIGNATION D	EACH	2								2	
* 83050810	LIGHT POLE, ALUMINUM, 47.5 FT. M.H., 15 FT. MAST ARM	EACH	26								26	
* 83050860	LIGHT POLE, ALUMINUM, 47.5 FT. M.H., 2-6 FT. MAST ARMS	EACH	42								42	
* 83600200	LIGHT POLE FOUNDATION, 24" DIAMETER	FOOT	182								182	
* 83800205	BREAKAWAY DEVICE, TRANSFORMER BASE, 15 INCH BOLT CIRCLE	EACH	26								26	
* 84200505	REMOVAL OF LIGHTING TOWER, SALVAGE	EACH	1								1	
* 84200605	REMOVAL OF LIGHTING TOWER, NO SALVAGE	EACH	22								22	
* 84200804	REMOVAL OF POLE FOUNDATION	EACH	7								7	

\* DENOTES SPECIALTY ITEM

① SN 099-N1009, SN 099-N1010, SN 099-N1011, SN 099-N1012, SN 099-N1013, SN 099-N1014 & SN 099-N1015



USER NAME = amkluver	DESIGNED - VLJ	REVISED -
PLOT SCALE = 0.16666633 1/ in.	DRAWN - AMK	REVISED -
PLOT DATE = 8/18/2023	CHECKED - JMG	REVISED -
	DATE - 6/26/23	REVISED -

**STATE OF ILLINOIS  
 DEPARTMENT OF TRANSPORTATION**

**SUMMARY OF QUANTITIES**

SCALE: NONE SHEET 12 OF 16 SHEETS STA. TO STA.

F.A.I. RTE.	SECTION	COUNTY	TOTAL SHEETS	SHEET NO.
I-80	FAI 80 21 STRUCTURE 6	WILL	898	16
ILLINOIS FED. AID PROJECT			CONTRACT NO. 62R27	

MODEL: S00-13  
 FILE NAME: p:\transys\transys\comp\pw\_bentley\transys\transys\comp\pw\_bentley\Documents\Projects\_2018\CH401\401180022\02-TransSystems\CAD\02R27\Sheet\03-Schedule\03-Schedule.dgn

CODE NUMBER	PAY ITEM	UNIT	TOTAL QUANTITY	ROADWAY	ROADWAY	CULVERT	BRIDGE REHAB	BRIDGE REHAB	NOISE ABATEMENT WALLS ①	SAFETY	SAFETY
				90% FED		90% FED	90% FED	90% FED	90% FED	90% FED	90% FED
				10% STATE	100% STATE	10% STATE	10% STATE	10% STATE	10% STATE	10% STATE	100% STATE
				0003	0003	0004	0013	0013	0020	0021	
			URBAN	RURAL	RURAL	099-0760	099-0301	099-0302	RURAL	LIGHTING	LIGHTING
* 85000200	MAINTENANCE OF EXISTING TRAFFIC SIGNAL INSTALLATION	EACH	1							1	
* 87800100	CONCRETE FOUNDATION, TYPE A	FOOT	15							15	
* 87800400	CONCRETE FOUNDATION, TYPE E 30-INCH DIAMETER	FOOT	50							50	
* 88600700	PREFORMED DETECTOR LOOP	FOOT	95							95	
* 89502300	REMOVE ELECTRIC CABLE FROM CONDUIT	FOOT	23,640							23,640	
* 89502350	REMOVE AND REINSTALL ELECTRIC CABLE FROM CONDUIT	FOOT	571							571	
* 89502380	REMOVE EXISTING HANDHOLE	EACH	26							26	
* 89502385	REMOVE EXISTING CONCRETE FOUNDATION	EACH	1							1	
* E20210G1	VINE-PARTHENOCISSUS QUINQUEFOLIA ENGEL MANNII (ENGELMANNII VIRGINIA CREEPER), 1-GALLON POT	EACH	3,712	3,712							
K1003660	MOWING CYCLES	EACH	21	21							
* K1004595	PRUNING FOR SAFETY AND EQUIPMENT CLEARANCE	L SUM	1	1							
X0301423	NOISE ABATEMENT WALL, GROUND MOUNTED	SQ FT	110,834						110,834		
X0323879	SERVICE PATROL	CAL DA	1,095	1,095							
X0324013	NOISE ABATEMENT WALL, STRUCTURE MOUNTED	SQ FT	5,048						5,048		
X0324097	COARSE SAND PLACEMENT, 2"	SQ YD	72,201	72,201							
X0324587	NOISE ABATEMENT WALL ANCHOR ROD ASSEMBLY	EACH	48						48		
X0325222	WEED CONTROL, BASAL TREATMENT	GALLON	50	50							
X0325734	SLOTTED DRAIN REMOVAL	FOOT	850	850							
* X0326944	ATMS INTEGRATION	L SUM	1							1	
X0327120	WEED CONTROL, NATIVE LANDSCAPE ENHANCEMENT	ACRE	1.75	1.75							
* X0327186	PORTABLE VIDEO TOWER STATIONS	CAL MO	1,411							1,411	

\* DENOTES SPECIALTY ITEM

① SN 099-N1009, SN 099-N1010, SN 099-N1011, SN 099-N1012, SN 099-N1013, SN 099-N1014 & SN 099-N1015



USER NAME = amkluver	DESIGNED - VLJ	REVISED -
PLOT SCALE = 0.16666633 1/16 in.	DRAWN - AMK	REVISED -
PLOT DATE = 8/18/2023	CHECKED - JMG	REVISED -
	DATE - 6/26/23	REVISED -

**STATE OF ILLINOIS  
DEPARTMENT OF TRANSPORTATION**

**SUMMARY OF QUANTITIES**

SCALE: NONE SHEET 13 OF 16 SHEETS STA. TO STA.

F.A.I. RTE.	SECTION	COUNTY	TOTAL SHEETS	SHEET NO.
I-80	FAI 80 21 STRUCTURE 6	WILL	898	17
			CONTRACT NO. 62R27	
		ILLINOIS	FED. AID PROJECT	



MODEL: S00-14  
 FILE NAME: p:\transys\transys\comp\pw\checked\Documents\Projects\_2018\CH401401180022\02-TransSystems\CAD\02R27\02R27\03-Schedule\03-Schedule.dwg\03-Schedule.dwg

CODE NUMBER	PAY ITEM	UNIT	TOTAL QUANTITY	ROADWAY	ROADWAY	CULVERT	BRIDGE REHAB	BRIDGE REHAB	NOISE ABATEMENT WALLS ①	SAFETY	SAFETY
				90% FED		90% FED	90% FED	90% FED	90% FED	90% FED	90% FED
				10% STATE	100% STATE	10% STATE	10% STATE	10% STATE	10% STATE	10% STATE	100% STATE
				0003	0003	0004	0013	0013	0020	0021	0021
				RURAL	RURAL	099-0760	099-0301	099-0302	RURAL	LIGHTING	LIGHTING
X0900064	MEMBRANE WATERPROOFING SYSTEM FOR BURIED STRUCTURES	SQ YD	624			624					
X0931400	INLET BOXES TO BE ADJUSTED (SPECIAL)	EACH	2	2							
X1400190	REMOVAL OF HIGH MAST LUMINAIRES, SALVAGE	EACH	82							82	
* X1400450	REBUILD EXISTING HEAVY-DUTY HANDHOLE	EACH	2							2	
X1700036	CONCRETE BARRIER BASE (SPECIAL NO. 1)	FOOT	781	781							
X1700037	CONCRETE BARRIER BASE (SPECIAL NO. 2)	FOOT	1,050	1,050							
* X2010350	TREE REMOVAL, ACRES (SPECIAL)	ACRE	1.75	1.75							
X4210400	LUG SYSTEM REMOVAL	EACH	12	12							
X5030250	BRIDGE DECK GROOVING (LONGITUDINAL)	SQ YD	1,674				837	837			
X5060601	CONTAINMENT AND DISPOSAL OF NON-LEAD PAINT CLEANING RESIDUES NO. 1	L SUM	1				1				
X5060602	CONTAINMENT AND DISPOSAL OF NON-LEAD PAINT CLEANING RESIDUES NO. 2	L SUM	1					1			
X5427602	REMOVE EXISTING FLARED END SECTION	EACH	8	8							
X5509900	ABANDON AND FILL EXISTING STORM SEWER	FOOT	400	400							
X6020073	INLETS, TYPE A, TYPE 8 GRATE, TEMPORARY	EACH	27	27							
X6420002	FILLING EXISTING RUMBLE STRIP	FOOT	120	120							
X6700410	ENGINEER'S FIELD OFFICE, TYPE A (SPECIAL)	CAL MO	36	36							
X7010216	TRAFFIC CONTROL AND PROTECTION, (SPECIAL)	L SUM	1	1							
X7010238	CHANGEABLE MESSAGE SIGN (SPECIAL)	CAL MO	157							157	
X7011015	TRAFFIC CONTROL AND PROTECTION (EXPRESSWAYS)	L SUM	1	1							
X7013820	TRAFFIC CONTROL SURVEILLANCE, EXPRESSWAYS	CAL DA	1,095	1,095							
X7040652	REMOVE TEMPORARY CONCRETE BARRIER, STATE OWNED	FOOT	12.5	12.5							

\* DENOTES SPECIALTY ITEM

① SN 099-N1009, SN 099-N1010, SN 099-N1011, SN 099-N1012, SN 099-N1013, SN 099-N1014 & SN 099-N1015



USER NAME = amkluver	DESIGNED - VLJ	REVISED -
PLOT SCALE = 0.16666633 1/16 in.	DRAWN - AMK	REVISED -
PLOT DATE = 8/18/2023	CHECKED - JMG	REVISED -
	DATE - 6/26/23	REVISED -

**STATE OF ILLINOIS  
DEPARTMENT OF TRANSPORTATION**

**SUMMARY OF QUANTITIES**

SCALE: NONE SHEET 14 OF 16 SHEETS STA. TO STA.

F.A.I. RTE.	SECTION	COUNTY	TOTAL SHEETS	SHEET NO.
I-80	FAI 80 21 STRUCTURE 6	WILL	898	18
			CONTRACT NO. 62R27	
		ILLINOIS	FED. AID PROJECT	

MODEL: SQO-15  
 FILE NAME: p:\transys\transys\comp\pw\_bentley.com\transys\comp\pw\_bentley.com\transys\transys\CAD\62R27\Drawings\03-Schedule\62R27-SHT-SQO.dgn

CODE NUMBER	PAY ITEM	UNIT	TOTAL QUANTITY	ROADWAY	ROADWAY	CULVERT	BRIDGE REHAB	BRIDGE REHAB	NOISE ABATEMENT WALLS ①	SAFETY	SAFETY
				90% FED		90% FED	90% FED	90% FED	90% FED	90% FED	90% FED
				10% STATE	100% STATE	10% STATE	10% STATE	10% STATE	10% STATE	10% STATE	100% STATE
				0003	0003	0008	0013	0013	0020	0021	
			URBAN	RURAL	RURAL	099-0760	099-0301	099-0302	RURAL	LIGHTING	LIGHTING
* X8130115	DRILL EXISTING JUNCTION BOX	EACH	2							2	
X8211002	PROTECT AND MAINTAIN EXISTING UNDERPASS LUMINAIRE	L SUM	1							1	
* X8360103	LIGHT POLE FOUNDATION, INTEGRAL WITH BARRIER WALL	EACH	43							43	
X8360105	LIGHT POLE FOUNDATION, INTEGRAL WITH BARRIER WALL, 24" DIAMETER	FOOT	301							301	
X8410122	DISCONNECT SIGN LIGHTING AND REMOVE WIRING TO NEAREST SPLICE	EACH	1							1	
* X8420510	REMOVAL OF TOWER FOUNDATION	EACH	23							23	
* X8710318	FIBER OPTIC UTILITY MARKER	EACH	63							42	21
* X8710402	FIBER OPTIC INNERDUCT 1 1/4" DIA.	FOOT	1,302							1,302	
* X8780200	CONCRETE FOUNDATION, SURVEILLANCE CABINET MODEL 334	EACH	1							1	
* X8950425	REMOVE EXISTING TRAFFIC SURVEILLANCE EQUIPMENT	L SUM	1							1	
* X8950450	REMOVE EXISTING UNDERGROUND CONDUIT	FOOT	16							16	
* X8950510	REMOVE FIBER OPTIC CABLE FROM CONDUIT	FOOT	25,376							25,376	
Z0004552	APPROACH SLAB REMOVAL	SQ YD	579	579							
Z0001904	STRUCTURAL STEEL REMOVAL	L SUM	1.0				0.5	0.5			
Z0010501	CLEANING AND PAINTING STEEL BRIDGE NO. 1	L SUM	1				1				
Z0010502	CLEANING AND PAINTING STEEL BRIDGE NO. 2	L SUM	1					1			
Z0013797	STABILIZED CONSTRUCTION ENTRANCE	SQ YD	5,560	5,560							
Z0013798	CONSTRUCTION LAYOUT	L SUM	1	1							
Z0018500	DRAINAGE STRUCTURES TO BE CLEANED	EACH	2		2						
Z0022800	FENCE REMOVAL	FOOT	17,157	17,157							
Z0029090	DIAMOND GRINDING (BRIDGE SECTION)	SQ YD	3,226				1,613	1,613			

\* DENOTES SPECIALTY ITEM

① SN 099-N1009, SN 099-N1010, SN 099-N1011, SN 099-N1012, SN 099-N1013, SN 099-N1014 & SN 099-N1015

**TRANSYSTEMS**

USER NAME = amkluver	DESIGNED - VLJ	REVISED -
PLOT SCALE = 0.16666633 1/ in.	DRAWN - AMK	REVISED -
PLOT DATE = 8/18/2023	CHECKED - JMG	REVISED -
	DATE - 6/26/23	REVISED -

**STATE OF ILLINOIS  
DEPARTMENT OF TRANSPORTATION**

**SUMMARY OF QUANTITIES**

SCALE: NONE SHEET 15 OF 16 SHEETS STA. TO STA.

F.A.I. RTE.	SECTION	COUNTY	TOTAL SHEETS	SHEET NO.
I-80	FAI 80 21 STRUCTURE 6	WILL	898	19
			CONTRACT NO. 62R27	
		ILLINOIS	FED. AID PROJECT	

MODEL: S00-16  
 FILE NAME: p:\transystems\pw\_bentley.com\transyscorp\pw1\hosted\Documents\Projects\_2018\CH40140118002202-TransSystems\CAD\2R27\Sheets\03-Schedule\03ER27-SHT-S00.dgn

CODE NUMBER	PAY ITEM	UNIT	TOTAL QUANTITY	ROADWAY	ROADWAY	CULVERT	BRIDGE REHAB	BRIDGE REHAB	NOISE ABATEMENT WALLS ①	SAFETY	SAFETY
				90% FED		90% FED	90% FED	90% FED	90% FED	90% FED	90% FED
				10% STATE	100% STATE	10% STATE	10% STATE	10% STATE	10% STATE	10% STATE	100% STATE
				URBAN							
				0003	0003	0004	0013	0013	0020	0021	0021
				RURAL	RURAL	099-0760	099-0301	099-0302	RURAL	LIGHTING	LIGHTING
Z0030850	TEMPORARY INFORMATION SIGNING	SQ FT	1,389	1,389							
Z0030910	TRANSFER SERVICE SIGN	EACH	52	52							
* Z0033020	LUMINAIRE SAFETY CABLE ASSEMBLY	EACH	110							110	
* Z0033028	MAINTENANCE OF LIGHTING SYSTEM	CAL MO	36							36	
* Z0033052	COMMUNICATIONS VAULT	EACH	21							14	7
Z0038121	PORTLAND CEMENT CONCRETE SURFACE REMOVAL 2"	SQ YD	9,034	9,034							
Z0062456	TEMPORARY PAVEMENT	SQ YD	54,253	54,253							
Z0065745	SLOTTED DRAIN 12" WITH 2 1/2" SLOT	FOOT	850	850							
* X8131170	JUNCTION BOX, NON-METALLIC, EMBEDDED IN STRUCTURE, 20" X 13" X 12"	EACH	1							1	
X3110112	COARSE SAND PLACEMENT, 12"	SQ YD	137	137							
* X8101102	UNDERGROUND CONDUIT, MULTI-DUCT, 7-18MM MICRODUCTS	FOOT	33,641							22,016	11,625
* 81101002	CONDUIT ATTACHED TO STRUCTURE, RIGID NONMETALLIC, 4" DIA.	FOOT	600							400	200
* X8570006	SMART TRAFFIC MONITORING SYSTEM	CAL MO	36							36	
X0325280	EXPRESSWAY SWEEPING CYCLES	EACH	15	15							
Ø Z0076600	TRAINEES	HOURS	2,500	2,500							
Ø Z0076604	TRAINEES - TRAINING PROGRAM GRADUATE	HOURS	2,500	2,500							

\* DENOTES SPECIALTY ITEM

① SN 099-N1009, SN 099-N1010, SN 099-N1011, SN 099-N1012, SN 099-N1013, SN 099-N1014 & SN 099-N1015



USER NAME = amkluver	DESIGNED - VLJ	REVISED -
DRAWN - AMK	REVISIONS -	
PLOT SCALE = 0.16666633 1/ in.	CHECKED - JMG	REVISED -
PLOT DATE = 8/18/2023	DATE - 6/26/23	REVISED -

**STATE OF ILLINOIS  
DEPARTMENT OF TRANSPORTATION**

**SUMMARY OF QUANTITIES**

SCALE: NONE SHEET 16 OF 16 SHEETS STA. TO STA.

F.A.I. RTE.	SECTION	COUNTY	TOTAL SHEETS	SHEET NO.
I-80	FAI 80 21 STRUCTURE 6	WILL	898	20
			CONTRACT NO. 62R27	
		ILLINOIS	FED. AID PROJECT	

0042

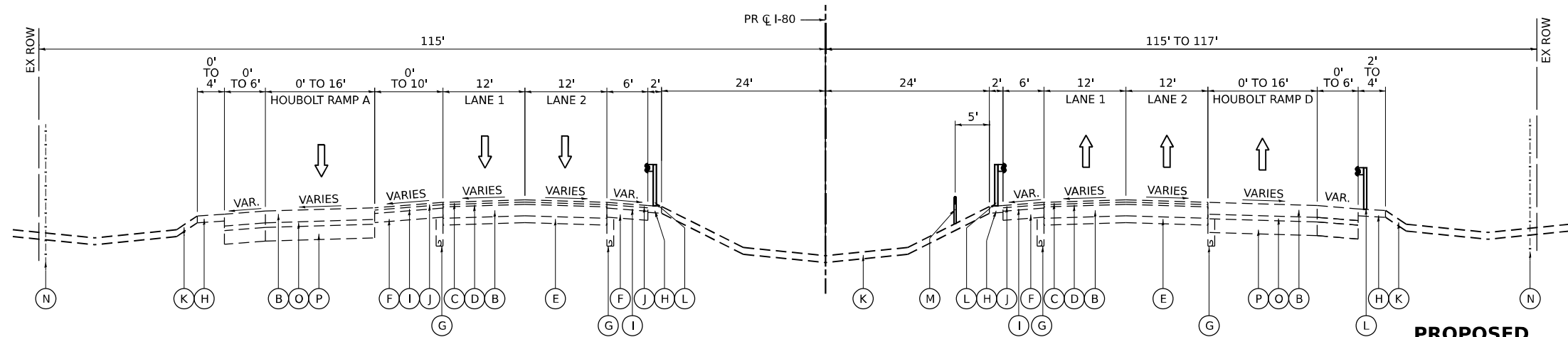

**EXISTING TYPICAL SECTION**

PR  $\bar{C}$  I-80  
 STA 410+00.00 TO STA 428+80.45

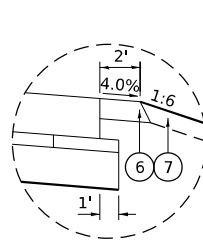

**DETAIL A**  
 AGGREGATE SHOULDER  
 ALL TYPICAL SECTIONS

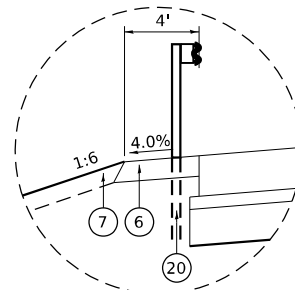

**DETAIL B**  
 STEEL PLATE BEAM GUARDRAIL  
 EB I-80 STA 410+00.00 TO STA 411+25.00  
 WB I-80 STA 415+29.95 TO STA 428+80.45  
 EB I-80 STA 427+67.13 TO STA 428+80.45

**PROPOSED**

- 1 CONTINUOUSLY REINFORCED PORTLAND CEMENT CONCRETE PAVEMENT 13"
- 2 STABILIZED SUBBASE - HOT-MIX ASPHALT, 4"
- 3 AGGREGATE SUBGRADE IMPROVEMENT 12"
- 4 PORTLAND CEMENT CONCRETE SHOULDERS 13"
- 5 SUBBASE GRANULAR MATERIAL, TYPE C 4"
- 6 AGGREGATE SHOULDERS, TYPE B 6" (SEE DETAIL A)
- 7 TOPSOIL EXCAVATION AND PLACEMENT AND SEEDING  
(SEE LANDSCAPING PLANS FOR DETAILS AND PAY ITEMS)
- 8 PIPE UNDERDRAINS, TYPE 2, 6"
- 9 DRILL AND GROUT TIE BARS PER STANDARD 420001-10 (INCLUDED IN THE COST CONCRETE MEDIAN AND PCC SHOULDERS OF THICKNESS SPECIFIED)
- 10 PORTLAND CEMENT CONCRETE PAVEMENT 11½" (JOINTED)
- 11 PORTLAND CEMENT CONCRETE SHOULDERS 11½"
- 12 TIE BARS PER STANDARD 420001-10 (INCLUDED IN THE COST OF PCC PAVEMENT, PCC BASE COURSE AND PCC SHOULDERS OF THICKNESS SPECIFIED) SEE JOINTING PLANS FOR ADDITIONAL INFORMATION
- 13 CONCRETE BARRIER, DOUBLE FACE, 44 INCH HEIGHT W/ HOOK BARS
- 14 CONCRETE BARRIER, VARIABLE CROSS SECTION 44 INCH HEIGHT W/ HOOK BARS
- 15 CONCRETE BARRIER, SINGLE FACE, 44 INCH HEIGHT
- 16 CONCRETE BARRIER BASE
- 17 CONCRETE BARRIER BASE (SPECIAL NO. 1)
- 18 CONCRETE BARRIER BASE (SPECIAL NO. 2)
- 19 SHOULDER RUMBLE STRIPS, 16 INCH
- 20 STEEL PLATE BEAM GUARDRAIL, TYPE A, 6 FOOT POSTS
- 21 CONCRETE MEDIAN, TYPE SM-6.24
- 22 COMBINATION CONCRETE CURB & GUTTER, TYPE B-6.24
- 23 NOISE ABATEMENT WALL (SEE PLANS FOR DETAILS)
- 24 CONSTRUCTION JOINT AND DOWEL BARS (INCLUDED IN THE COST OF CRC PAVEMENT) SEE JOINTING DETAILS FOR ADDITIONAL INFORMATION
- 25 CONCRETE GUTTER, TYPE B
- 26 CONCRETE MEDIAN SURFACE, 4"
- 27 CHAIN LINK FENCE, 4'
- 28 AGGREGATE BASE COURSE, TYPE B 6"

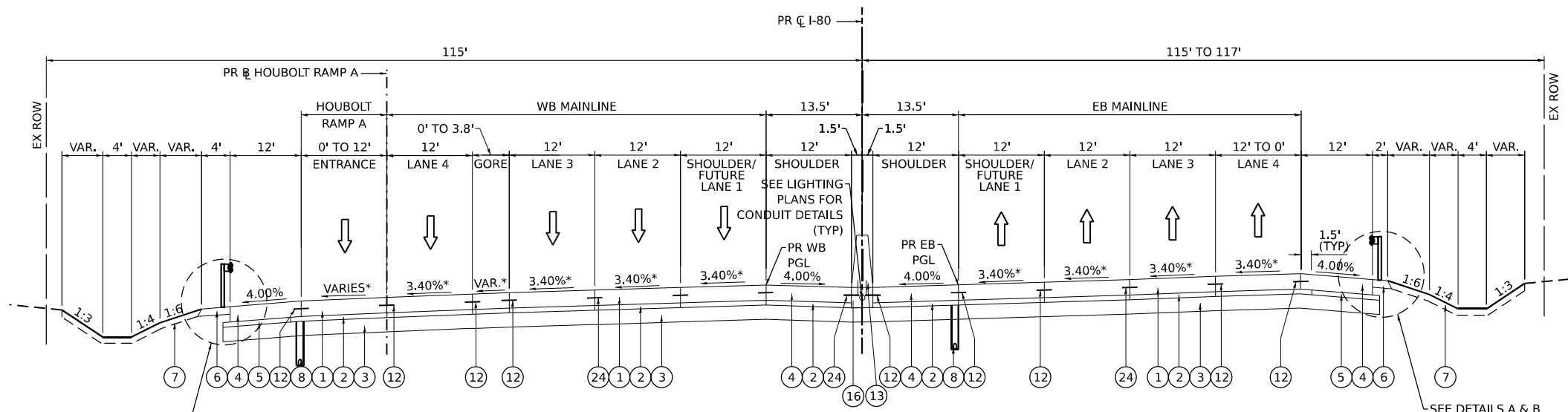

**PROPOSED TYPICAL SECTION**

PR  $\bar{C}$  I-80  
 STA 410+00.00 TO STA 428+88.98

**NOTES:**

1. THE MAXIMUM ROLLOVER BETWEEN THE PAVEMENT AND THE SHOULDER ON THE HIGH SIDE OF THE SUPERELEVATION IS 8%.
2. FOR CONTINUOUSLY REINFORCED PORTLAND CEMENT CONCRETE PAVEMENT (JOINTED) DETAILS SEE JOINTING AND SUPERELEVATION PLAN.
- \* 3. SEE SUPER ELEVATION SHEETS 86 TO 87 FOR TRANSITION CROSS SLOPE INFORMATION.



USER NAME = amkluver	DESIGNED - VLJ	REVISED -
PLOT SCALE = 0.16666633 1/16"	DRAWN - AMK	REVISED -
PLOT DATE = 6/23/2023	CHECKED - JMG	REVISED -
	DATE - 6/26/23	REVISED -

STATE OF ILLINOIS  
 DEPARTMENT OF TRANSPORTATION

TYPICAL SECTIONS  
 I-80

SCALE: NONE SHEET 1 OF 11 SHEETS STA. TO STA.

F.A.I. RTE.	SECTION	COUNTY	TOTAL SHEETS	SHEET NO.
I-80	FAI 80 21 STRUCTURE 6	WILL	898	21
CONTRACT NO. 62R27				
ILLINOIS FED. AID PROJECT				

MODEL: TYP-01  
 FILE NAME: p:\transystems\pmp\benby.com\transystems\pmp\shared\Documents\Projects\_2018\C401401180022\02-TransSystems\CAD\62R27\Sheets\03-TYP\_Sec D\62R27-SHT-TYPICAL

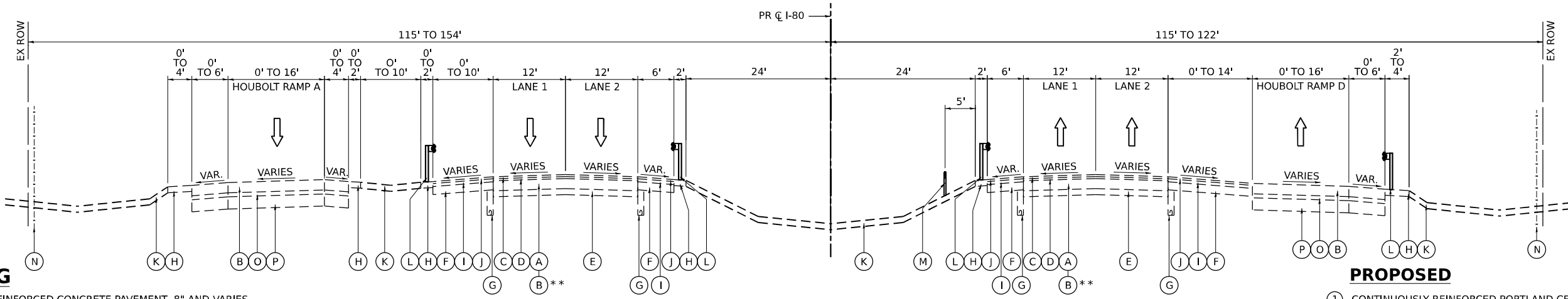

**EXISTING**

- (A) CONTINUOUSLY REINFORCED CONCRETE PAVEMENT, 8" AND VARIES
- (B) PORTLAND CEMENT CONCRETE PAVEMENT (10" AND VARIES)
- (C) STONE MATRIX ASPHALT, SURFACE COURSE, 2"
- (D) STONE MATRIX ASPHALT, BINDER COURSE, 2"
- (E) SUBBASE GRANULAR MATERIAL, 6"
- (F) HOT-MIX ASPHALT SHOULDER, 8"
- (G) PIPE UNDERDRAIN
- (H) AGGREGATE SHOULDER
- (I) EXISTING 3" HOT-MIX ASPHALT OVERLAY
- (J) BITUMINOUS CONCRETE SURFACE COURSE, SUPERPAVE MIX "C" N50, 2"
- (K) GROUND SURFACE (ASSUMED EXISTING 6" TOPSOIL DEPTH)
- (L) GUARDRAIL
- (M) CABLE BARRIER
- (N) EXISTING FENCE
- (O) STABILIZED SUBBASE (4" AND VARIES)
- (P) AGGREGATE SUBGRADE (12" AND VARIES)
- (Q) BIT. CONC. SURFACE CSE., MIX E, CLASS 1, TY. 2, 2"
- (R) BIT. CONC. BINDER CSE., MIX B, TY. 2, 1.5"
- (S) BITUMINOUS SHOULDER, 10"
- (T) PORTLAND CEMENT CONCRETE SHOULDER, 10"
- (U) BRIDGE PIER

\*\* FOR STA 428+78.90 TO STA 431+96.25

**EXISTING TYPICAL SECTION**

PR C I-80  
STA 428+80.45 TO STA 434+41.72

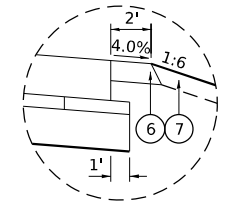

**DETAIL A**  
AGGREGATE SHOULDER  
ALL TYPICAL SECTIONS

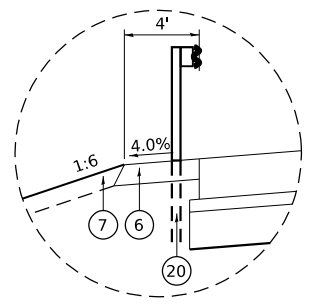

**DETAIL B**  
STEEL PLATE BEAM GUARDRAIL  
WB I-80 STA 428+80.45 TO STA 434+23.01  
EB I-80 STA 428+80.45 TO STA 434+41.72

**NOTES:**

1. THE MAXIMUM ROLLOVER BETWEEN THE PAVEMENT AND THE SHOULDER ON THE HIGH SIDE OF THE SUPERELEVATION IS 8%.
2. FOR CONTINUOUSLY REINFORCED PORTLAND CEMENT CONCRETE PAVEMENT (JOINTED) DETAILS SEE JOINTING AND SUPERELEVATION PLAN.
- \* 3. SEE SUPER ELEVATION SHEETS 86 TO 87 FOR TRANSITION CROSS SLOPE INFORMATION.

\*\*\* USE RAMP PCC PAVEMENT AND SHOULDER FROM STA 432+27.13 TO STA 433+43.73  
\*\*\*\* USE RAMP PCC PAVEMENT AND SHOULDER FROM STA 428+88.98 TO STA 433+43.73

**PROPOSED**

- (1) CONTINUOUSLY REINFORCED PORTLAND CEMENT CONCRETE PAVEMENT 13"
- (2) STABILIZED SUBBASE - HOT-MIX ASPHALT, 4"
- (3) AGGREGATE SUBGRADE IMPROVEMENT 12"
- (4) PORTLAND CEMENT CONCRETE SHOULDERS 13"
- (5) SUBBASE GRANULAR MATERIAL, TYPE C 4"
- (6) AGGREGATE SHOULDERS, TYPE B 6" (SEE DETAIL A)
- (7) TOPSOIL EXCAVATION AND PLACEMENT AND SEEDING (SEE LANDSCAPING PLANS FOR DETAILS AND PAY ITEMS)
- (8) PIPE UNDERDRAINS, TYPE 2, 6"
- (9) DRILL AND GROUT TIE BARS PER STANDARD 420001-10 (INCLUDED IN THE COST OF CONCRETE MEDIAN AND PCC SHOULDERS OF THICKNESS SPECIFIED)
- (10) PORTLAND CEMENT CONCRETE PAVEMENT 11 1/2" (JOINTED)
- (11) PORTLAND CEMENT CONCRETE SHOULDERS 11 1/2"
- (12) TIE BARS PER STANDARD 420001-10 (INCLUDED IN THE COST OF PCC PAVEMENT, PCC BASE COURSE AND PCC SHOULDERS OF THICKNESS SPECIFIED) SEE JOINTING PLANS FOR ADDITIONAL INFORMATION
- (13) CONCRETE BARRIER, DOUBLE FACE, 44 INCH HEIGHT W/ HOOK BARS
- (14) CONCRETE BARRIER, VARIABLE CROSS SECTION 44 INCH HEIGHT W/ HOOK BARS
- (15) CONCRETE BARRIER, SINGLE FACE, 44 INCH HEIGHT
- (16) CONCRETE BARRIER BASE
- (17) CONCRETE BARRIER BASE (SPECIAL NO. 1)
- (18) CONCRETE BARRIER BASE (SPECIAL NO. 2)
- (19) SHOULDER RUMBLE STRIPS, 16 INCH
- (20) STEEL PLATE BEAM GUARDRAIL, TYPE A, 6 FOOT POSTS
- (21) CONCRETE MEDIAN, TYPE SM-6.24
- (22) COMBINATION CONCRETE CURB & GUTTER, TYPE B-6.24
- (23) NOISE ABATEMENT WALL (SEE PLANS FOR DETAILS)
- (24) CONSTRUCTION JOINT AND DOWEL BARS (INCLUDED IN THE COST OF CRC PAVEMENT) SEE JOINTING DETAILS FOR ADDITIONAL INFORMATION
- (25) CONCRETE GUTTER, TYPE B
- (26) CONCRETE MEDIAN SURFACE, 4"
- (27) CHAIN LINK FENCE, 4'
- (28) AGGREGATE BASE COURSE, TYPE B 6"

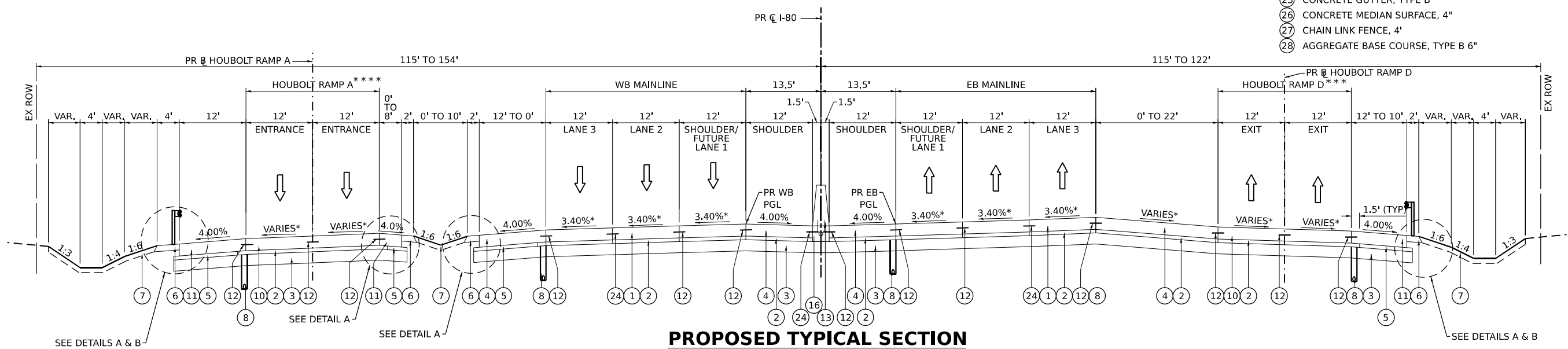

**PROPOSED TYPICAL SECTION**

PR C I-80  
STA 428+88.98 TO STA 434+41.72



USER NAME = amkluver	DESIGNED - VLJ	REVISED -
PLOT SCALE = 0.16666633 1/ in.	DRAWN - AMK	REVISED -
PLOT DATE = 6/23/2023	CHECKED - JMG	REVISED -
	DATE - 6/26/23	REVISED -

**STATE OF ILLINOIS  
DEPARTMENT OF TRANSPORTATION**

<b>TYPICAL SECTIONS</b>		F.A.I. RTE.	SECTION	COUNTY	TOTAL SHEETS	SHEET NO.
I-80		I-80	FAI 80 21 STRUCTURE 6	WILL	898	22
SCALE: NONE		SHEET 2 OF 11 SHEETS		STA.	TO STA.	

CONTRACT NO. 62R27		ILLINOIS	FED. AID PROJECT
--------------------	--	----------	------------------

MODEL: TYP-02  
FILE NAME: p:\transys\transys\comp\ppl\checked\Documents\Projects\_2018\CI-40114011.80022\02-TransSystems\CAD\022827\Figures\02-Typ\_Sec\022827-SH-T-TYPICAL



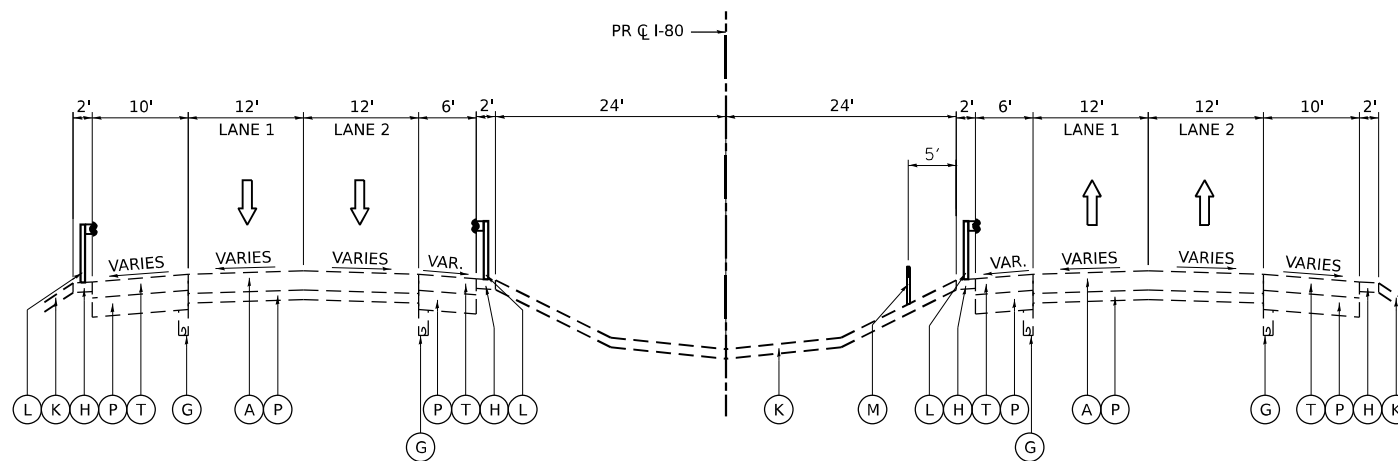

### EXISTING TYPICAL SECTION

PR C I-80  
 STA 434+41.72 TO STA 443+64.76  
 STA 445+73.76 TO STA 454+73.11

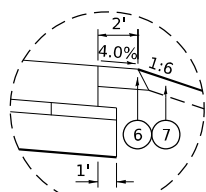

**DETAIL A**  
 AGGREGATE SHOULDER  
 ALL TYPICAL SECTIONS

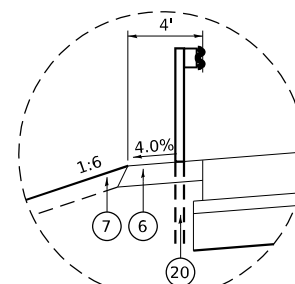

**DETAIL B**

STEEL PLATE BEAM GUARDRAIL  
 EB I-80 STA 434+41.72 TO STA 436+47.69  
 WB I-80 STA 435+02.16 TO STA 436+78.73  
 EB I-80 STA 437+44.44 TO STA 443+27.01  
 WB I-80 STA 442+69.06 TO STA 443+82.89  
 EB I-80 STA 445+54.95 TO STA 446+67.45  
 WB I-80 STA 446+12.72 TO STA 453+87.73

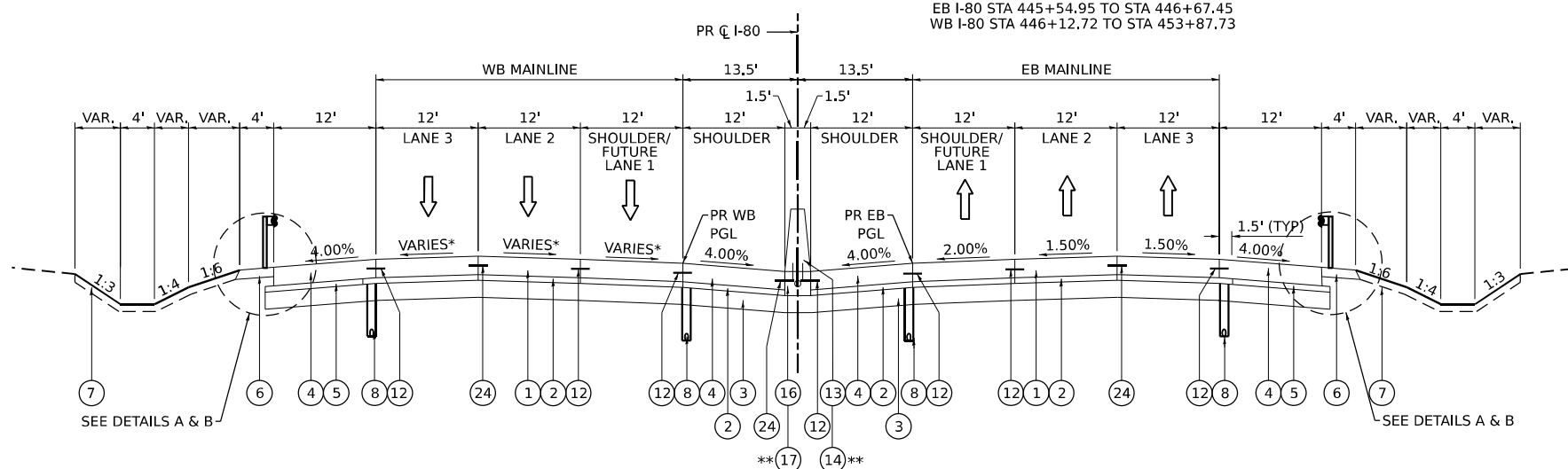

### PROPOSED TYPICAL SECTION

PR C I-80  
 STA 434+41.72 TO STA 443+64.76  
 STA 445+73.76 TO STA 454+73.11

BRIDGES (SN 099-0301 & SN 099-0302) INCLUDING APPROACH PAVEMENT  
 STA 443+64.76 TO STA 445+73.76

### PROPOSED

- 1 CONTINUOUSLY REINFORCED PORTLAND CEMENT CONCRETE PAVEMENT 13"
- 2 STABILIZED SUBBASE - HOT-MIX ASPHALT, 4"
- 3 AGGREGATE SUBGRADE IMPROVEMENT 12"
- 4 PORTLAND CEMENT CONCRETE SHOULDERS 13"
- 5 SUBBASE GRANULAR MATERIAL, TYPE C 4"
- 6 AGGREGATE SHOULDERS, TYPE B 6" (SEE DETAIL A)
- 7 TOPSOIL EXCAVATION AND PLACEMENT AND SEEDING (SEE LANDSCAPING PLANS FOR DETAILS AND PAY ITEMS)
- 8 PIPE UNDERDRAINS, TYPE 2, 6"
- 9 DRILL AND GROUT TIE BARS PER STANDARD 420001-10 (INCLUDED IN THE COST CONCRETE MEDIAN AND PCC SHOULDERS OF THICKNESS SPECIFIED)
- 10 PORTLAND CEMENT CONCRETE PAVEMENT 11½" (JOINTED)
- 11 PORTLAND CEMENT CONCRETE SHOULDERS 11½"
- 12 TIE BARS PER STANDARD 420001-10 (INCLUDED IN THE COST OF PCC PAVEMENT, PCC BASE COURSE AND PCC SHOULDERS OF THICKNESS SPECIFIED) SEE JOINTING PLANS FOR ADDITIONAL INFORMATION
- 13 CONCRETE BARRIER, DOUBLE FACE, 44 INCH HEIGHT W/ HOOK BARS
- 14 CONCRETE BARRIER, VARIABLE CROSS SECTION 44 INCH HEIGHT W/ HOOK BARS
- 15 CONCRETE BARRIER, SINGLE FACE, 44 INCH HEIGHT
- 16 CONCRETE BARRIER BASE
- 17 CONCRETE BARRIER BASE (SPECIAL NO. 1)
- 18 CONCRETE BARRIER BASE (SPECIAL NO. 2)
- 19 SHOULDER RUMBLE STRIPS, 16 INCH
- 20 STEEL PLATE BEAM GUARDRAIL, TYPE A, 6 FOOT POSTS
- 21 CONCRETE MEDIAN, TYPE SM-6.24
- 22 COMBINATION CONCRETE CURB & GUTTER, TYPE B-6.24
- 23 NOISE ABATEMENT WALL (SEE PLANS FOR DETAILS)
- 24 CONSTRUCTION JOINT AND DOWEL BARS (INCLUDED IN THE COST OF CRC PAVEMENT) SEE JOINTING DETAILS FOR ADDITIONAL INFORMATION
- 25 CONCRETE GUTTER, TYPE B
- 26 CONCRETE MEDIAN SURFACE, 4"
- 27 CHAIN LINK FENCE, 4"
- 28 AGGREGATE BASE COURSE, TYPE B 6"

### NOTES:

1. THE MAXIMUM ROLLOVER BETWEEN THE PAVEMENT AND THE SHOULDER ON THE HIGH SIDE OF THE SUPERELEVATION IS 8%.
2. FOR CONTINUOUSLY REINFORCED PORTLAND CEMENT CONCRETE PAVEMENT (JOINTED) DETAILS SEE JOINTING AND SUPERELEVATION PLAN.
- \* 3. SEE SUPER ELEVATION SHEETS 86 TO 87 FOR TRANSITION CROSS SLOPE INFORMATION.
- \*\* 4. CONCRETE BARRIER VARIABLE CROSS SECTION AND CONCRETE BARRIER BASE (SPECIAL NO. 1) FROM STA 439+14.38 TO STA 449+78.42.
5. SEE CONCRETE BARRIER DETAIL SHEETS FOR VARIABLE CROSS SECTION INFORMATION.

MODEL: TYP-03  
 FILE NAME: p:\transys\transys\comp\pw\homed\Documents\Projects\_2018\CI-401\401180022\02-TransSystemsCAD\0227\Sheet\03-Typ\_Sec\0227-SFT-TYPICAL



USER NAME = amkluver	DESIGNED - VLJ	REVISED -
PLOT SCALE = 0.16666633 1/ in.	DRAWN - AMK	REVISED -
PLOT DATE = 6/23/2023	CHECKED - JMG	REVISED -
	DATE - 6/26/23	REVISED -

**STATE OF ILLINOIS  
 DEPARTMENT OF TRANSPORTATION**

TYPICAL SECTIONS	
I-80	
SCALE: NONE	SHEET 3 OF 11 SHEETS STA. TO STA.

F.A.I. RTE.	SECTION	COUNTY	TOTAL SHEETS	SHEET NO.
I-80	FAI 80 21 STRUCTURE 6	WILL	898	23
			CONTRACT NO. 62R27	
ILLINOIS FED. AID PROJECT				

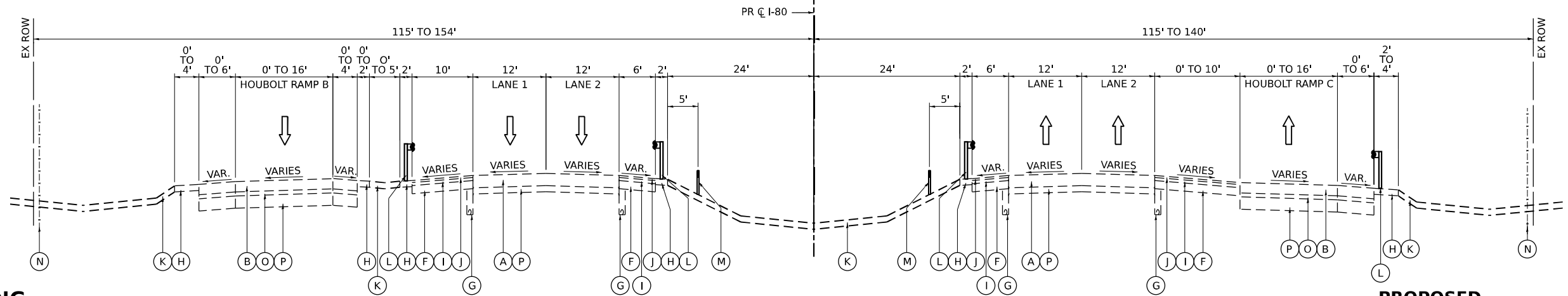

**EXISTING**

- (A) CONTINUOUSLY REINFORCED CONCRETE PAVEMENT, 8" AND VARIES
- (B) PORTLAND CEMENT CONCRETE PAVEMENT (10" AND VARIES)
- (C) STONE MATRIX ASPHALT, SURFACE COURSE, 2"
- (D) STONE MATRIX ASPHALT, BINDER COURSE, 2"
- (E) SUBBASE GRANULAR MATERIAL, 6"
- (F) HOT-MIX ASPHALT SHOULDER, 8"
- (G) PIPE UNDERDRAIN
- (H) AGGREGATE SHOULDER
- (I) EXISTING 3" HOT-MIX ASPHALT OVERLAY
- (J) BITUMINOUS CONCRETE SURFACE COURSE, SUPERPAVE MIX "C" N50, 2"
- (K) GROUND SURFACE (ASSUMED EXISTING 6" TOPSOIL DEPTH)
- (L) GUARDRAIL
- (M) CABLE BARRIER
- (N) EXISTING FENCE
- (O) STABILIZED SUBBASE (4" AND VARIES)
- (P) AGGREGATE SUBGRADE (12" AND VARIES)
- (Q) BIT. CONC. SURFACE CSE., MIX E, CLASS 1, TY. 2, 2"
- (R) BIT. CONC. BINDER CSE., MIX B, TY. 2, 1.5"
- (S) BITUMINOUS SHOULDER, 10"
- (T) PORTLAND CEMENT CONCRETE SHOULDER, 10"
- (U) BRIDGE PIER

- \* USE RAMP PCC PAVEMENT AND SHOULDER FROM STA 455+98.53 TO STA 458+76.12
- \*\* USE RAMP PCC PAVEMENT AND SHOULDER FROM STA 455+98.53 TO STA 458+11.19
- \*\*\* STA 455+98.53 TO STA 457+90.00

**EXISTING TYPICAL SECTION**

PR CL I-80  
STA 454+73.11 TO STA 460+24.95

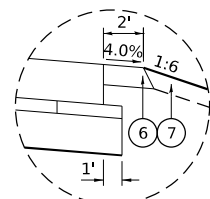

**DETAIL A**

AGGREGATE SHOULDER  
ALL TYPICAL SECTIONS

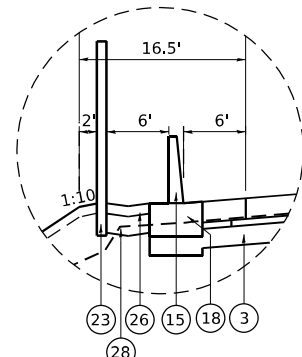

**DETAIL B**

NOISE ABATEMENT WALL  
W/ CONC BARRIER SINGLE  
FACE  
I-80 WESTBOUND  
STA 456+65.10 TO  
STA 457+66.61 LT

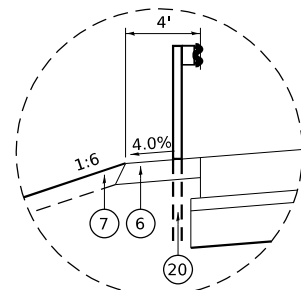

**DETAIL C**

STEEL PLATE BEAM GUARDRAIL  
WB I-80 STA 458+02.89 TO STA 460+24.95

**NOTES:**

1. THE MAXIMUM ROLLOVER BETWEEN THE PAVEMENT AND THE SHOULDER ON THE HIGH SIDE OF THE SUPERELEVATION IS 8%.
2. FOR CONTINUOUSLY REINFORCED PORTLAND CEMENT CONCRETE PAVEMENT (JOINTED) DETAILS SEE JOINTING AND SUPERELEVATION PLAN.

**PROPOSED**

- (1) CONTINUOUSLY REINFORCED PORTLAND CEMENT CONCRETE PAVEMENT 13"
- (2) STABILIZED SUBBASE - HOT-MIX ASPHALT, 4"
- (3) AGGREGATE SUBGRADE IMPROVEMENT 12"
- (4) PORTLAND CEMENT CONCRETE SHOULDERS 13"
- (5) SUBBASE GRANULAR MATERIAL, TYPE C 4"
- (6) AGGREGATE SHOULDERS, TYPE B 6" (SEE DETAIL A)
- (7) TOPSOIL EXCAVATION AND PLACEMENT AND SEEDING (SEE LANDSCAPING PLANS FOR DETAILS AND PAY ITEMS)
- (8) PIPE UNDERDRAINS, TYPE 2, 6"
- (9) DRILL AND GROUT TIE BARS PER STANDARD 420001-10 (INCLUDED IN THE COST OF CONCRETE MEDIAN AND PCC SHOULDERS OF THICKNESS SPECIFIED)
- (10) PORTLAND CEMENT CONCRETE PAVEMENT 11 1/2" (JOINTED)
- (11) PORTLAND CEMENT CONCRETE SHOULDERS 11 1/2"
- (12) TIE BARS PER STANDARD 420001-10 (INCLUDED IN THE COST OF PCC PAVEMENT, PCC BASE COURSE AND PCC SHOULDERS OF THICKNESS SPECIFIED) SEE JOINTING PLANS FOR ADDITIONAL INFORMATION
- (13) CONCRETE BARRIER, DOUBLE FACE, 44 INCH HEIGHT W/ HOOK BARS
- (14) CONCRETE BARRIER, VARIABLE CROSS SECTION 44 INCH HEIGHT W/ HOOK BARS
- (15) CONCRETE BARRIER, SINGLE FACE, 44 INCH HEIGHT
- (16) CONCRETE BARRIER BASE
- (17) CONCRETE BARRIER BASE (SPECIAL NO. 1)
- (18) CONCRETE BARRIER BASE (SPECIAL NO. 2)
- (19) SHOULDER RUMBLE STRIPS, 16 INCH
- (20) STEEL PLATE BEAM GUARDRAIL, TYPE A, 6 FOOT POSTS
- (21) CONCRETE MEDIAN, TYPE SM-6.24
- (22) COMBINATION CONCRETE CURB & GUTTER, TYPE B-6.24
- (23) NOISE ABATEMENT WALL (SEE PLANS FOR DETAILS)
- (24) CONSTRUCTION JOINT AND DOWEL BARS (INCLUDED IN THE COST OF CRC PAVEMENT) SEE JOINTING DETAILS FOR ADDITIONAL INFORMATION
- (25) CONCRETE GUTTER, TYPE B
- (26) CONCRETE MEDIAN SURFACE, 4"
- (27) CHAIN LINK FENCE, 4"
- (28) AGGREGATE BASE COURSE, TYPE B 6"

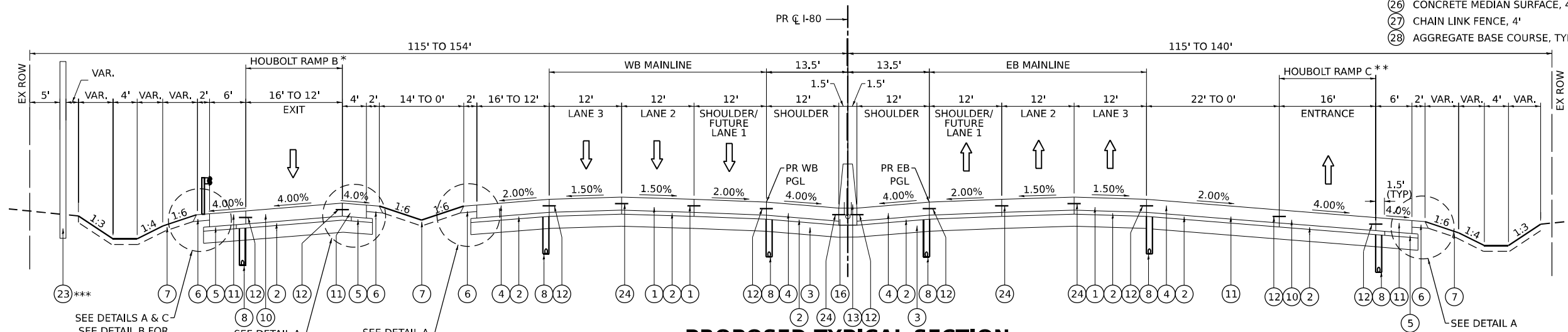

**PROPOSED TYPICAL SECTION**

PR CL I-80  
STA 454+73.11 TO STA 460+24.95



USER NAME = amkluver	DESIGNED - VLJ	REVISED -
PLOT SCALE = 0.16666633 1/16"	DRAWN - AMK	REVISED -
PLOT DATE = 6/23/2023	CHECKED - JMG	REVISED -
	DATE - 6/26/23	REVISED -

STATE OF ILLINOIS  
DEPARTMENT OF TRANSPORTATION

TYPICAL SECTIONS			
I-80			
SCALE: NONE	SHEET 4	OF 11 SHEETS	STA. TO STA.

F.A.I. RTE.	SECTION	COUNTY	TOTAL SHEETS	SHEET NO.
I-80	FAI 80 21 STRUCTURE 6	WILL	898	24
CONTRACT NO. 62R27				
ILLINOIS FED. AID PROJECT				

MODEL: TYP-04  
 FILE NAME: p:\transys\transys\comp\p4\checked\Documents\Projects\_2018\CH4011401180022\02-TransSystemsCAD\02R27\Structs\03-Typ\_Sec\02R27-SFT-TYPICAL

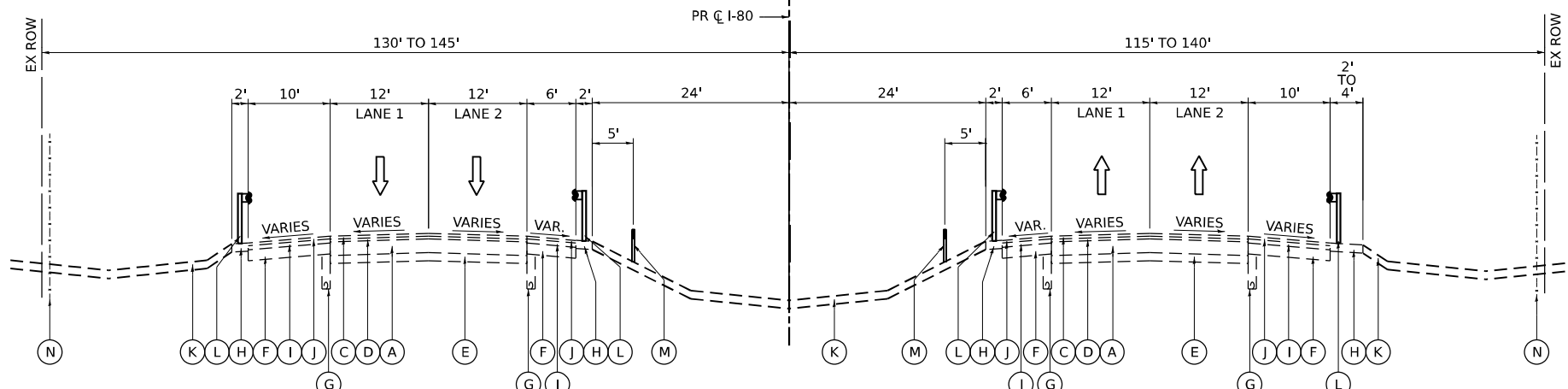

**EXISTING TYPICAL SECTION**

PR C I-80  
STA 460+24.95 TO STA 477+99.96

**EXISTING**

- (A) CONTINUOUSLY REINFORCED CONCRETE PAVEMENT, 8" AND VARIES
- (B) PORTLAND CEMENT CONCRETE PAVEMENT (10" AND VARIES)
- (C) STONE MATRIX ASPHALT, SURFACE COURSE, 2"
- (D) STONE MATRIX ASPHALT, BINDER COURSE, 2"
- (E) SUBBASE GRANULAR MATERIAL, 6"
- (F) HOT-MIX ASPHALT SHOULDER, 8"
- (G) PIPE UNDERDRAIN
- (H) AGGREGATE SHOULDER
- (I) EXISTING 3" HOT-MIX ASPHALT OVERLAY
- (J) BITUMINOUS CONCRETE SURFACE COURSE, SUPERPAVE MIX "C" N50, 2"
- (K) GROUND SURFACE (ASSUMED EXISTING 6" TOPSOIL DEPTH)
- (L) GUARDRAIL
- (M) CABLE BARRIER
- (N) EXISTING FENCE
- (O) STABILIZED SUBBASE (4" AND VARIES)
- (P) AGGREGATE SUBGRADE (12" AND VARIES)
- (Q) BIT. CONC. SURFACE CSE., MIX E, CLASS 1, TY. 2, 2"
- (R) BIT. CONC. BINDER CSE., MIX B, TY. 2, 1.5"
- (S) BITUMINOUS SHOULDER, 10"
- (T) PORTLAND CEMENT CONCRETE SHOULDER, 10"
- (U) BRIDGE PIER

**PROPOSED**

- (1) CONTINUOUSLY REINFORCED PORTLAND CEMENT CONCRETE PAVEMENT 13"
- (2) STABILIZED SUBBASE - HOT-MIX ASPHALT, 4"
- (3) AGGREGATE SUBGRADE IMPROVEMENT 12"
- (4) PORTLAND CEMENT CONCRETE SHOULDERS 13"
- (5) SUBBASE GRANULAR MATERIAL, TYPE C 4"
- (6) AGGREGATE SHOULDERS, TYPE B 6" (SEE DETAIL A)
- (7) TOPSOIL EXCAVATION AND PLACEMENT AND SEEDING (SEE LANDSCAPING PLANS FOR DETAILS AND PAY ITEMS)
- (8) PIPE UNDERDRAINS, TYPE 2, 6"
- (9) DRILL AND GROUT TIE BARS PER STANDARD 420001-10 (INCLUDED IN THE COST CONCRETE MEDIAN AND PCC SHOULDERS OF THICKNESS SPECIFIED)
- (10) PORTLAND CEMENT CONCRETE PAVEMENT 11½" (JOINTED)
- (11) PORTLAND CEMENT CONCRETE SHOULDERS 11½"
- (12) TIE BARS PER STANDARD 420001-10 (INCLUDED IN THE COST OF PCC PAVEMENT, PCC BASE COURSE AND PCC SHOULDERS OF THICKNESS SPECIFIED) SEE JOINTING PLANS FOR ADDITIONAL INFORMATION
- (13) CONCRETE BARRIER, DOUBLE FACE, 44 INCH HEIGHT W/ HOOK BARS
- (14) CONCRETE BARRIER, VARIABLE CROSS SECTION 44 INCH HEIGHT W/ HOOK BARS
- (15) CONCRETE BARRIER, SINGLE FACE, 44 INCH HEIGHT
- (16) CONCRETE BARRIER BASE
- (17) CONCRETE BARRIER BASE (SPECIAL NO. 1)
- (18) CONCRETE BARRIER BASE (SPECIAL NO. 2)
- (19) SHOULDER RUMBLE STRIPS, 16 INCH
- (20) STEEL PLATE BEAM GUARDRAIL, TYPE A, 6 FOOT POSTS
- (21) CONCRETE MEDIAN, TYPE SM-6.24
- (22) COMBINATION CONCRETE CURB & GUTTER, TYPE B-6.24
- (23) NOISE ABATEMENT WALL (SEE PLANS FOR DETAILS)
- (24) CONSTRUCTION JOINT AND DOWEL BARS (INCLUDED IN THE COST OF CRC PAVEMENT) SEE JOINTING DETAILS FOR ADDITIONAL INFORMATION
- (25) CONCRETE GUTTER, TYPE B
- (26) CONCRETE MEDIAN SURFACE, 4"
- (27) CHAIN LINK FENCE, 4"
- (28) AGGREGATE BASE COURSE, TYPE B 6"

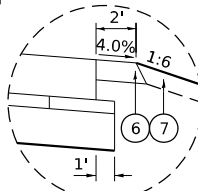

**DETAIL A**  
AGGREGATE SHOULDER  
ALL TYPICAL SECTIONS

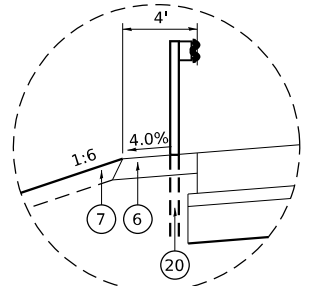

**DETAIL B**  
STEEL PLATE BEAM GUARDRAIL  
WB I-80 STA 460+24.95 TO STA 462+01.86

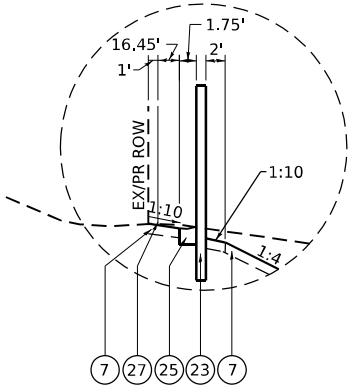

**DETAIL C**  
NOISE ABATEMENT WALL  
AT ROW  
ADJACENT PROPERTY  
DRAINING TO I-80 ROW  
I-80 WESTBOUND  
STA 472+25.00 TO STA  
477+99.96 LT

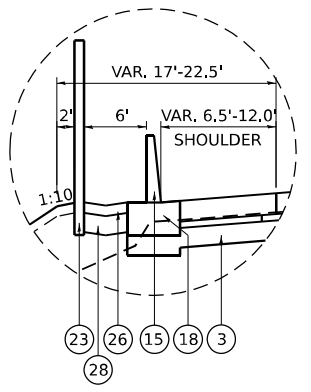

**DETAIL D**  
NOISE ABATEMENT WALL  
W/ CONC BARRIER SINGLE  
FACE  
I-80 WESTBOUND  
STA 476+75.00 TO STA  
477+99.96 LT

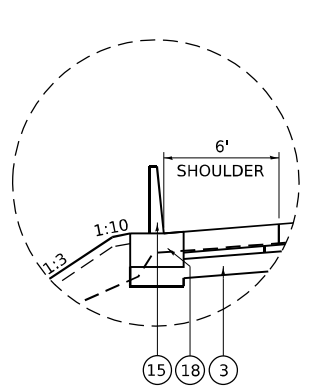

**DETAIL E**  
NOISE ABATEMENT WALL  
W/ CONC BARRIER SINGLE  
FACE  
I-80 WESTBOUND  
STA 475+00.00 TO  
STA 476+75.00 LT

\*\* STA 472+00.00 TO 477+99.96

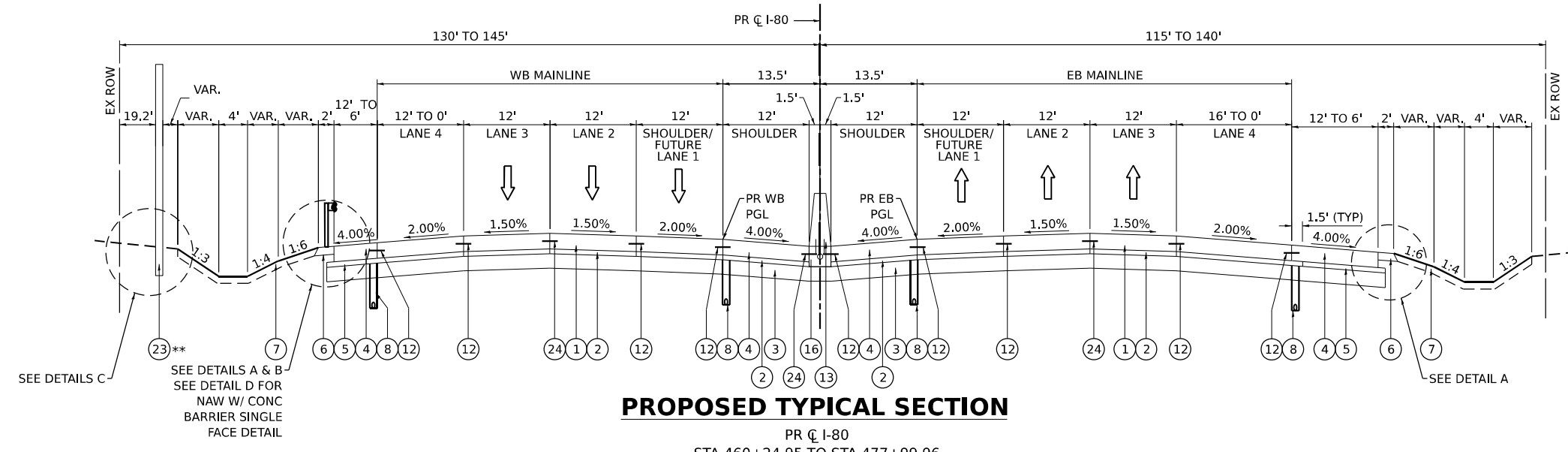

**PROPOSED TYPICAL SECTION**

PR C I-80  
STA 460+24.95 TO STA 477+99.96

**NOTES:**

1. THE MAXIMUM ROLLOVER BETWEEN THE PAVEMENT AND THE SHOULDER ON THE HIGH SIDE OF THE SUPERELEVATION IS 8%.
2. FOR CONTINUOUSLY REINFORCED PORTLAND CEMENT CONCRETE PAVEMENT (JOINTED) DETAILS SEE JOINTING AND SUPERELEVATION PLAN.

MODEL: TYP-05  
FILE NAME: p:\transys\transys\comp\ppl\checked\Documents\Projects\_2018\CH401180022\02-TransSystems\CAD\62R27\Structs\03-Typ\_Sec\0162R27-SHT-TYPICAL



USER NAME = amkluver	DESIGNED - VLJ	REVISED -
PLOT SCALE = 0.16666633 1/ in.	DRAWN - AMK	REVISED -
PLOT DATE = 6/23/2023	CHECKED - JMG	REVISED -
	DATE - 6/26/23	REVISED -

**STATE OF ILLINOIS  
DEPARTMENT OF TRANSPORTATION**

<b>TYPICAL SECTIONS</b>	
<b>I-80</b>	
SCALE: NONE	SHEET 5 OF 11 SHEETS
STA.	TO STA.

F.A.I. RTE.	SECTION	COUNTY	TOTAL SHEETS	SHEET NO.
I-80	FAI 80 21 STRUCTURE 6	WILL	898	25
CONTRACT NO. 62R27				
ILLINOIS FED. AID PROJECT				

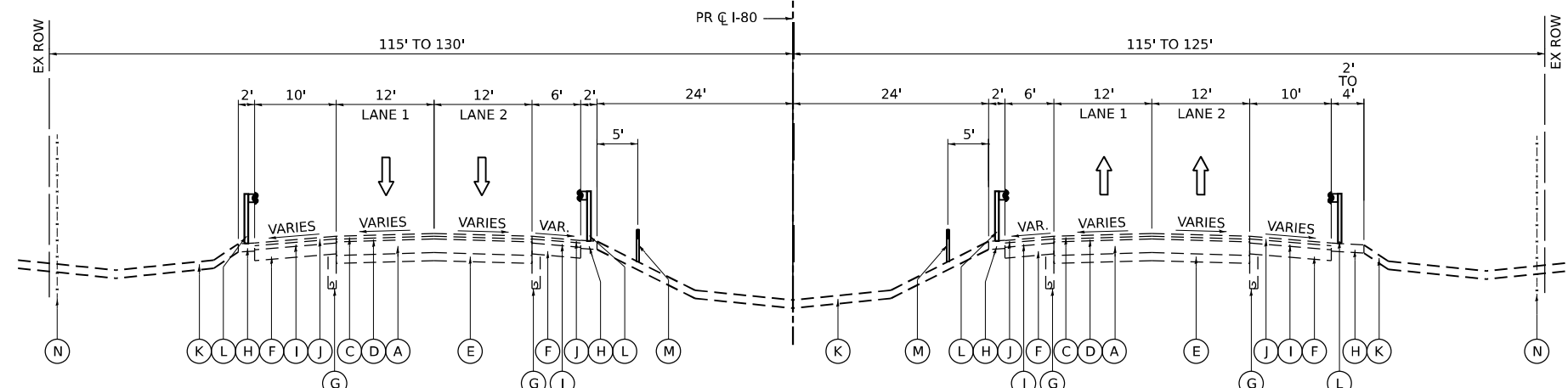

**EXISTING TYPICAL SECTION**

PR C I-80  
STA 477+99.96 TO STA 518+00.00

**EXISTING**

- (A) CONTINUOUSLY REINFORCED CONCRETE PAVEMENT, 8" AND VARIES
- (B) PORTLAND CEMENT CONCRETE PAVEMENT (10" AND VARIES)
- (C) STONE MATRIX ASPHALT, SURFACE COURSE, 2"
- (D) STONE MATRIX ASPHALT, BINDER COURSE, 2"
- (E) SUBBASE GRANULAR MATERIAL, 6"
- (F) HOT-MIX ASPHALT SHOULDER, 8"
- (G) PIPE UNDERDRAIN
- (H) AGGREGATE SHOULDER
- (I) EXISTING 3" HOT-MIX ASPHALT OVERLAY
- (J) BITUMINOUS CONCRETE SURFACE COURSE, SUPERPAVE MIX "C" N50, 2"
- (K) GROUND SURFACE (ASSUMED EXISTING 6" TOPSOIL DEPTH)
- (L) GUARDRAIL
- (M) CABLE BARRIER
- (N) EXISTING FENCE
- (O) STABILIZED SUBBASE (4" AND VARIES)
- (P) AGGREGATE SUBGRADE (12" AND VARIES)
- (Q) BIT. CONC. SURFACE CSE., MIX E, CLASS 1, TY. 2, 2"
- (R) BIT. CONC. BINDER CSE., MIX B, TY. 2, 1.5"
- (S) BITUMINOUS SHOULDER, 10"
- (T) PORTLAND CEMENT CONCRETE SHOULDER, 10"
- (U) BRIDGE PIER

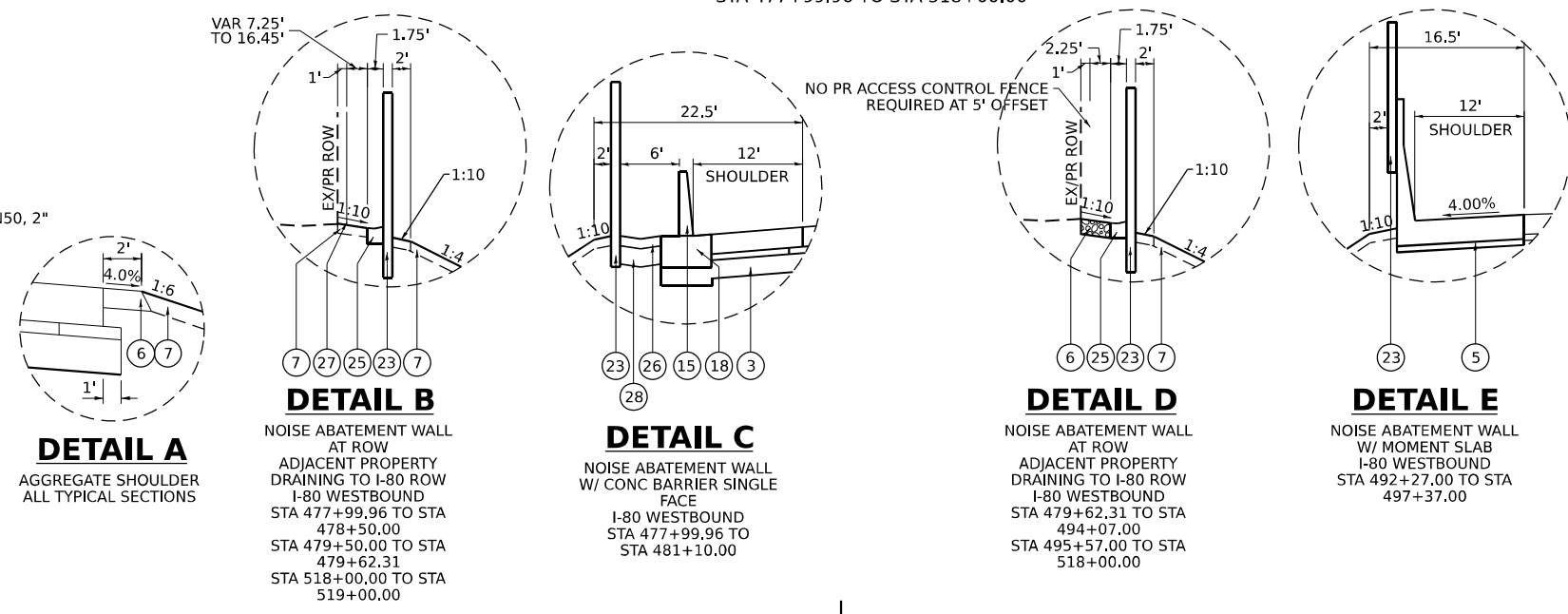

**PROPOSED**

- (1) CONTINUOUSLY REINFORCED PORTLAND CEMENT CONCRETE PAVEMENT 13"
- (2) STABILIZED SUBBASE - HOT-MIX ASPHALT, 4"
- (3) AGGREGATE SUBGRADE IMPROVEMENT 12"
- (4) PORTLAND CEMENT CONCRETE SHOULDERS 13"
- (5) SUBBASE GRANULAR MATERIAL, TYPE C 4"
- (6) AGGREGATE SHOULDERS, TYPE B 6" (SEE DETAIL A)
- (7) TOPSOIL EXCAVATION AND PLACEMENT AND SEEDING (SEE LANDSCAPING PLANS FOR DETAILS AND PAY ITEMS)
- (8) PIPE UNDERDRAINS, TYPE 2, 6"
- (9) DRILL AND GROUT TIE BARS PER STANDARD 420001-10 (INCLUDED IN THE COST CONCRETE MEDIAN AND PCC SHOULDERS OF THICKNESS SPECIFIED)
- (10) PORTLAND CEMENT CONCRETE PAVEMENT 11½" (JOINTED)
- (11) PORTLAND CEMENT CONCRETE SHOULDERS 11½"
- (12) TIE BARS PER STANDARD 420001-10 (INCLUDED IN THE COST OF PCC PAVEMENT, PCC BASE COURSE AND PCC SHOULDERS OF THICKNESS SPECIFIED) SEE JOINTING PLANS FOR ADDITIONAL INFORMATION
- (13) CONCRETE BARRIER, DOUBLE FACE, 44 INCH HEIGHT W/ HOOK BARS
- (14) CONCRETE BARRIER, VARIABLE CROSS SECTION 44 INCH HEIGHT W/ HOOK BARS
- (15) CONCRETE BARRIER, SINGLE FACE, 44 INCH HEIGHT
- (16) CONCRETE BARRIER BASE
- (17) CONCRETE BARRIER BASE (SPECIAL NO. 1)
- (18) CONCRETE BARRIER BASE (SPECIAL NO. 2)
- (19) SHOULDER RUMBLE STRIPS, 16 INCH
- (20) STEEL PLATE BEAM GUARDRAIL, TYPE A, 6 FOOT POSTS
- (21) CONCRETE MEDIAN, TYPE SM-6.24
- (22) COMBINATION CONCRETE CURB & GUTTER, TYPE B-6.24
- (23) NOISE ABATEMENT WALL (SEE PLANS FOR DETAILS)
- (24) CONSTRUCTION JOINT AND DOWEL BARS (INCLUDED IN THE COST OF CRC PAVEMENT) SEE JOINTING DETAILS FOR ADDITIONAL INFORMATION
- (25) CONCRETE GUTTER, TYPE B
- (26) CONCRETE MEDIAN SURFACE, 4"
- (27) CHAIN LINK FENCE, 4"
- (28) AGGREGATE BASE COURSE, TYPE B 6"

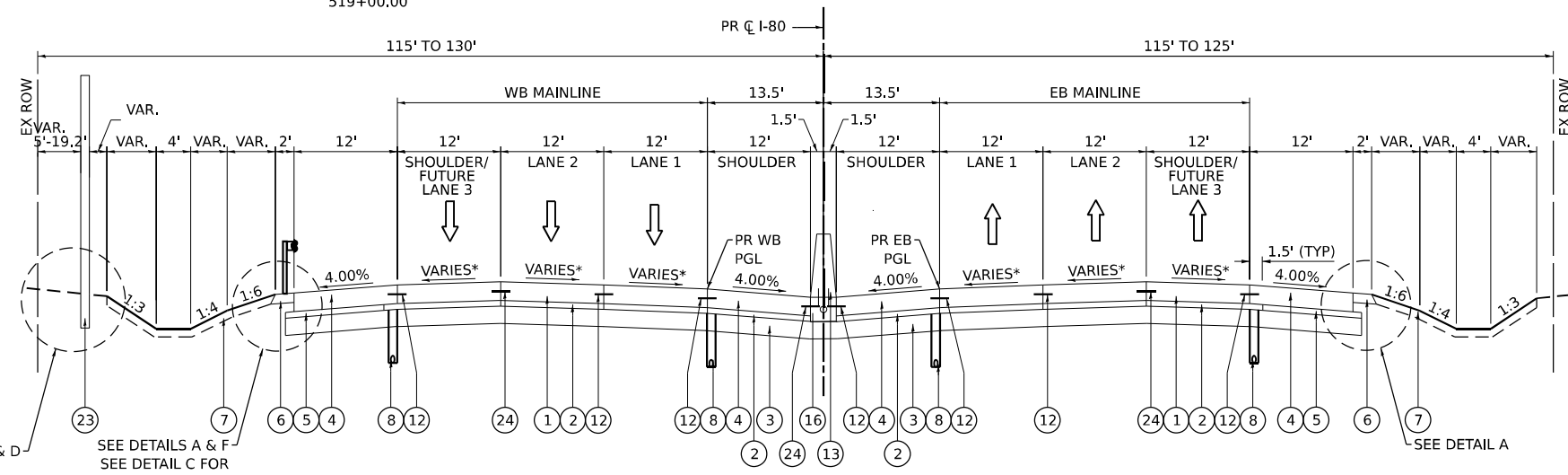

**PROPOSED TYPICAL SECTION**

PR C I-80  
STA 477+99.96 TO STA 518+00.00

**NOTES:**

1. THE MAXIMUM ROLLOVER BETWEEN THE PAVEMENT AND THE SHOULDER ON THE HIGH SIDE OF THE SUPERELEVATION IS 8%.
2. FOR CONTINUOUSLY REINFORCED PORTLAND CEMENT CONCRETE PAVEMENT (JOINTED) DETAILS SEE JOINTING AND SUPERELEVATION PLAN.
- \* 3. SEE SUPER ELEVATION SHEETS 86 TO 87 FOR TRANSITION CROSS SLOPE INFORMATION.

MODEL: TYP-06  
FILE NAME: p:\transys\transys\comp\p\p\checked\Documents\Projects\_2018\CI-401\4011.80022\02-TransSystemsCAD\022327\Struct\03-Typ\_Sec\01\02\03\Typ-TYPICAL



USER NAME = amkluver	DESIGNED - VLJ	REVISED -
	DRAWN - AMK	REVISED -
PLOT SCALE = 0.16666633 1/16"	CHECKED - JMG	REVISED -
PLOT DATE = 7/27/2023	DATE - 6/26/23	REVISED -

**STATE OF ILLINOIS  
DEPARTMENT OF TRANSPORTATION**

<b>TYPICAL SECTIONS</b>	
<b>I-80</b>	
SCALE: NONE	SHEET 6 OF 11 SHEETS
STA.	TO STA.

F.A.I. RTE.	SECTION	COUNTY	TOTAL SHEETS	SHEET NO.
I-80	FAI 80 21 STRUCTURE 6	WILL	898	26
			CONTRACT NO. 62R27	
ILLINOIS FED. AID PROJECT				

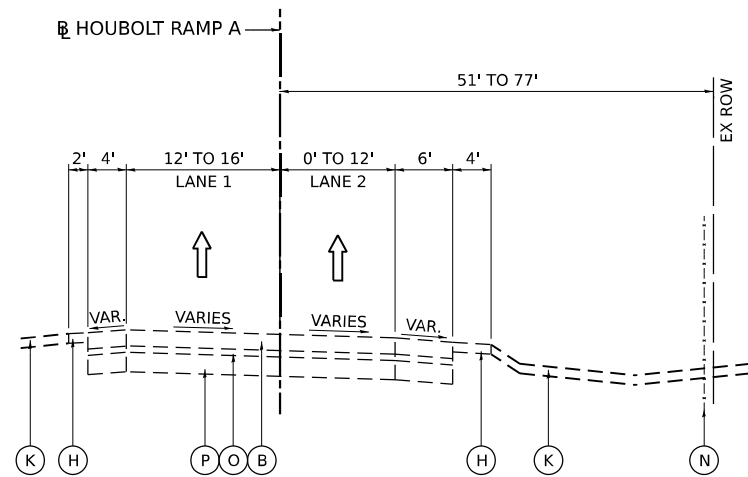

**EXISTING TYPICAL SECTION**

EX HOUBOLT RAMP A  
STA 1205+73.85 TO STA 1215+35.29

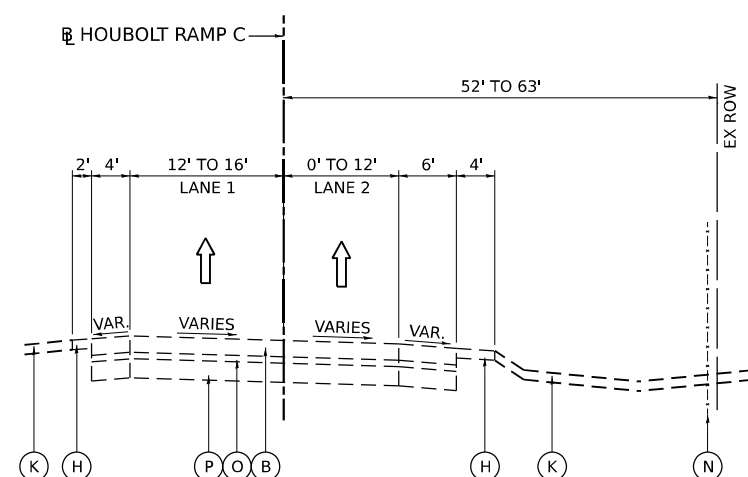

**EXISTING TYPICAL SECTION**

EX HOUBOLT RAMP C  
STA 308+14.11 TO STA 314+95.64

**EXISTING**

- (A) CONTINUOUSLY REINFORCED CONCRETE PAVEMENT, 8" AND VARIES
- (B) PORTLAND CEMENT CONCRETE PAVEMENT (10" AND VARIES)
- (C) STONE MATRIX ASPHALT, SURFACE COURSE, 2"
- (D) STONE MATRIX ASPHALT, BINDER COURSE, 2"
- (E) SUBBASE GRANULAR MATERIAL, 6"
- (F) HOT-MIX ASPHALT SHOULDER, 8"
- (G) PIPE UNDERDRAIN
- (H) AGGREGATE SHOULDER
- (I) EXISTING 3" HOT-MIX ASPHALT OVERLAY
- (J) BITUMINOUS CONCRETE SURFACE COURSE, SUPERPAVE MIX "C" N50, 2"
- (K) GROUND SURFACE (ASSUMED EXISTING 6" TOPSOIL DEPTH)
- (L) GUARDRAIL
- (M) CABLE BARRIER
- (N) EXISTING FENCE
- (O) STABILIZED SUBBASE (4" AND VARIES)
- (P) AGGREGATE SUBGRADE (12" AND VARIES)
- (Q) BIT. CONC. SURFACE CSE., MIX E, CLASS 1, TY. 2, 2"
- (R) BIT. CONC. BINDER CSE., MIX B, TY. 2, 1.5"
- (S) BITUMINOUS SHOULDER, 10"
- (T) PORTLAND CEMENT CONCRETE SHOULDER, 10"
- (U) BRIDGE PIER

**NOTES:**

1. THE MAXIMUM ROLLOVER BETWEEN THE PAVEMENT AND THE SHOULDER ON THE HIGH SIDE OF THE SUPERELEVATION IS 8%.
2. FOR CONTINUOUSLY REINFORCED PORTLAND CEMENT CONCRETE PAVEMENT (JOINTED) DETAILS SEE JOINTING AND SUPERELEVATION PLAN.
- \* 3. SEE SUPER ELEVATION SHEETS 86 TO 87 FOR TRANSITION CROSS SLOPE INFORMATION.

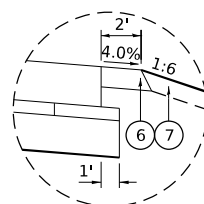

**DETAIL A**

AGGREGATE SHOULDER  
ALL TYPICAL SECTIONS

**PROPOSED**

- (1) CONTINUOUSLY REINFORCED PORTLAND CEMENT CONCRETE PAVEMENT 13"
- (2) STABILIZED SUBBASE - HOT-MIX ASPHALT, 4"
- (3) AGGREGATE SUBGRADE IMPROVEMENT 12"
- (4) PORTLAND CEMENT CONCRETE SHOULDERS 13"
- (5) SUBBASE GRANULAR MATERIAL, TYPE C 4"
- (6) AGGREGATE SHOULDERS, TYPE B 6" (SEE DETAIL A)
- (7) TOPSOIL EXCAVATION AND PLACEMENT AND SEEDING (SEE LANDSCAPING PLANS FOR DETAILS AND PAY ITEMS)
- (8) PIPE UNDERDRAINS, TYPE 2, 6"
- (9) DRILL AND GROUT TIE BARS PER STANDARD 420001-10 (INCLUDED IN THE COST OF CONCRETE MEDIAN AND PCC SHOULDERS OF THICKNESS SPECIFIED)
- (10) PORTLAND CEMENT CONCRETE PAVEMENT 11½" (JOINTED)
- (11) PORTLAND CEMENT CONCRETE SHOULDERS 11½"
- (12) TIE BARS PER STANDARD 420001-10 (INCLUDED IN THE COST OF PCC PAVEMENT, PCC BASE COURSE AND PCC SHOULDERS OF THICKNESS SPECIFIED) SEE JOINTING PLANS FOR ADDITIONAL INFORMATION
- (13) CONCRETE BARRIER, DOUBLE FACE, 44 INCH HEIGHT W/ HOOK BARS
- (14) CONCRETE BARRIER, VARIABLE CROSS SECTION 44 INCH HEIGHT W/ HOOK BARS
- (15) CONCRETE BARRIER, SINGLE FACE, 44 INCH HEIGHT
- (16) CONCRETE BARRIER BASE
- (17) CONCRETE BARRIER BASE (SPECIAL NO. 1)
- (18) CONCRETE BARRIER BASE (SPECIAL NO. 2)
- (19) SHOULDER RUMBLE STRIPS, 16 INCH
- (20) STEEL PLATE BEAM GUARDRAIL, TYPE A, 6 FOOT POSTS
- (21) CONCRETE MEDIAN, TYPE SM-6.24
- (22) COMBINATION CONCRETE CURB & GUTTER, TYPE B-6.24
- (23) NOISE ABATEMENT WALL (SEE PLANS FOR DETAILS)
- (24) CONSTRUCTION JOINT AND DOWEL BARS (INCLUDED IN THE COST OF CRC PAVEMENT) SEE JOINTING DETAILS FOR ADDITIONAL INFORMATION
- (25) CONCRETE GUTTER, TYPE B
- (26) CONCRETE MEDIAN SURFACE, 4"
- (27) CHAIN LINK FENCE, 4"
- (28) AGGREGATE BASE COURSE, TYPE B 6"

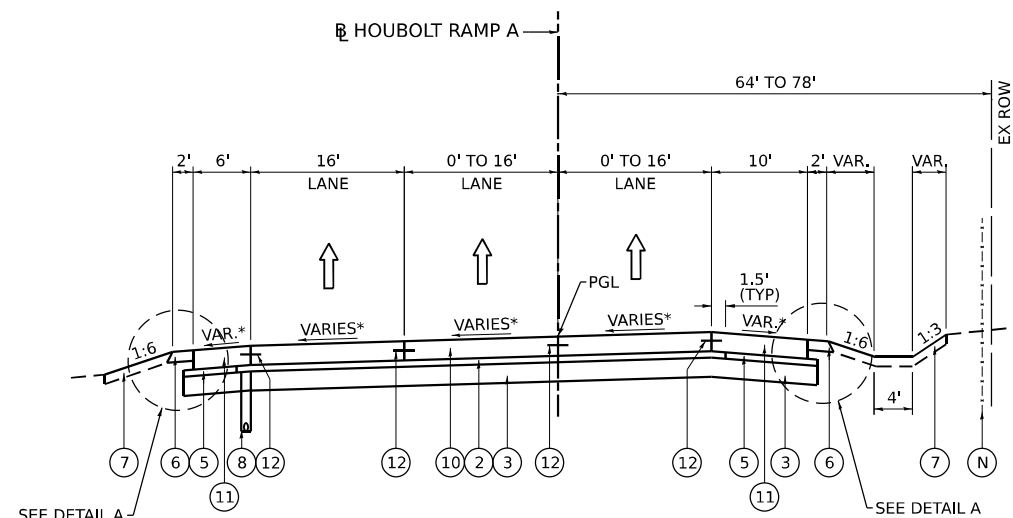

**PROPOSED TYPICAL SECTION**

PR HOUBOLT RAMP A  
STA 406+00.00 TO STA 415+71.27

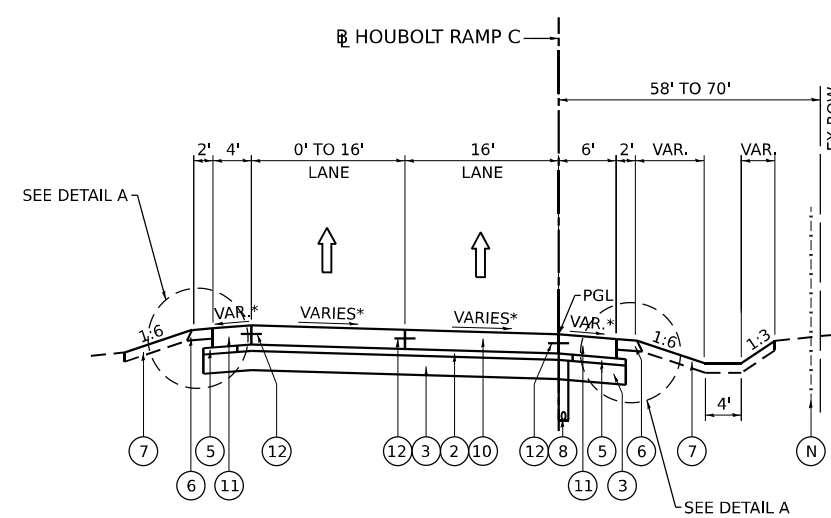

**PROPOSED TYPICAL SECTION**

PR HOUBOLT RAMP C  
STA 208+20.00 TO STA 215+03.68

MODEL: TYP-07  
FILE NAME: p:\transys\transys\comp\ppl\checked\Documents\Projects\_2018\CH401\401.180022\02-Transys\atms\CAD\022327\Figures\03-Typ\_Sec\012327-SH-TYPICAL

**TRANSYSTEMS**

USER NAME = amkluver	DESIGNED - VLJ	REVISED -
PLOT SCALE = 0.16666633 1/1 in.	DRAWN - AMK	REVISED -
PLOT DATE = 6/23/2023	CHECKED - JMG	REVISED -
	DATE - 6/26/23	REVISED -

**STATE OF ILLINOIS  
DEPARTMENT OF TRANSPORTATION**

**TYPICAL SECTIONS  
HOUBOLT INTERCHANGE RAMPS**

SCALE: NONE SHEET 7 OF 11 SHEETS STA. TO STA.

F.A.I. RTE.	SECTION	COUNTY	TOTAL SHEETS	SHEET NO.
I-80	FAI 80 21 STRUCTURE 6	WILL	898	27
CONTRACT NO. 62R27			ILLINOIS FED. AID PROJECT	

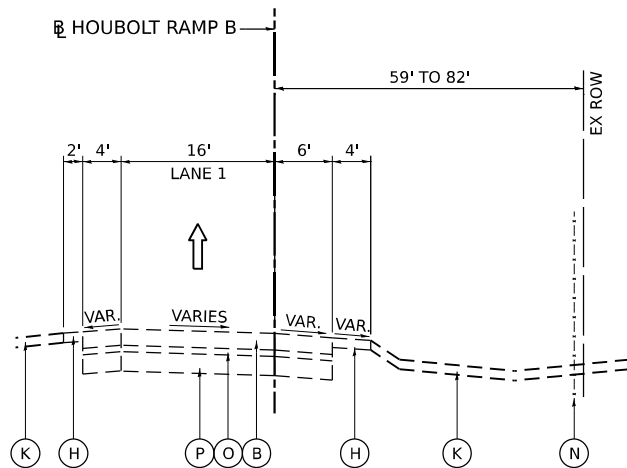

**EXISTING TYPICAL SECTION**

EX HOUBOLT RAMP B  
STA 200+00.00 TO STA 207+76.93

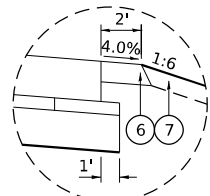

**DETAIL A**  
AGGREGATE SHOULDER  
ALL TYPICAL SECTIONS

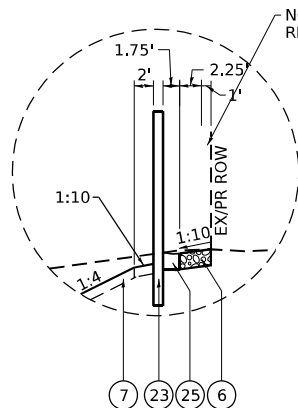

**DETAIL B**  
NOISE ABATEMENT WALL  
AT ROW  
ADJACENT PROPERTY  
DRAINING TO I-80 ROW  
HOUBOLT RAMP B  
STA 305+30.00 TO  
STA 312+19.82

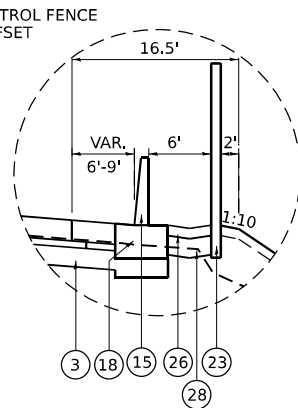

**DETAIL D**  
NOISE ABATEMENT WALL  
W/ CONC BARRIER SINGLE  
FACE  
HOUBOLT RAMP B  
STA 303+58.15 TO  
STA 307+00.00 RT

**EXISTING**

- (A) CONTINUOUSLY REINFORCED CONCRETE PAVEMENT, 8" AND VARIES
- (B) PORTLAND CEMENT CONCRETE PAVEMENT (10" AND VARIES)
- (C) STONE MATRIX ASPHALT, SURFACE COURSE, 2"
- (D) STONE MATRIX ASPHALT, BINDER COURSE, 2"
- (E) SUBBASE GRANULAR MATERIAL, 6"
- (F) HOT-MIX ASPHALT SHOULDER, 8"
- (G) PIPE UNDERDRAIN
- (H) AGGREGATE SHOULDER
- (I) EXISTING 3" HOT-MIX ASPHALT OVERLAY
- (J) BITUMINOUS CONCRETE SURFACE COURSE, SUPERPAVE MIX "C" N50, 2"
- (K) GROUND SURFACE (ASSUMED EXISTING 6" TOPSOIL DEPTH)
- (L) GUARDRAIL
- (M) CABLE BARRIER
- (N) EXISTING FENCE
- (O) STABILIZED SUBBASE (4" AND VARIES)
- (P) AGGREGATE SUBGRADE (12" AND VARIES)
- (Q) BIT. CONC. SURFACE CSE., MIX E, CLASS 1, TY. 2, 2"
- (R) BIT. CONC. BINDER CSE., MIX B, TY. 2, 1.5"
- (S) BITUMINOUS SHOULDER, 10"
- (T) PORTLAND CEMENT CONCRETE SHOULDER, 10"
- (U) BRIDGE PIER

**NOTES:**

1. THE MAXIMUM ROLLOVER BETWEEN THE PAVEMENT AND THE SHOULDER ON THE HIGH SIDE OF THE SUPERELEVATION IS 8%.
2. FOR CONTINUOUSLY REINFORCED PORTLAND CEMENT CONCRETE PAVEMENT (JOINTED) DETAILS SEE JOINTING AND SUPERELEVATION PLAN.
- \* 3. SEE SUPER ELEVATION SHEETS 86 TO 87 FOR TRANSITION CROSS SLOPE INFORMATION.

**PROPOSED**

- 1 CONTINUOUSLY REINFORCED PORTLAND CEMENT CONCRETE PAVEMENT 13"
- 2 STABILIZED SUBBASE - HOT-MIX ASPHALT, 4"
- 3 AGGREGATE SUBGRADE IMPROVEMENT 12"
- 4 PORTLAND CEMENT CONCRETE SHOULDERS 13"
- 5 SUBBASE GRANULAR MATERIAL, TYPE C 4"
- 6 AGGREGATE SHOULDERS, TYPE B 6" (SEE DETAIL A)
- 7 TOPSOIL EXCAVATION AND PLACEMENT AND SEEDING (SEE LANDSCAPING PLANS FOR DETAILS AND PAY ITEMS)
- 8 PIPE UNDERDRAINS, TYPE 2, 6"
- 9 DRILL AND GROUT TIE BARS PER STANDARD 420001-10 (INCLUDED IN THE COST OF CONCRETE MEDIAN AND PCC SHOULDERS OF THICKNESS SPECIFIED)
- 10 PORTLAND CEMENT CONCRETE PAVEMENT 11½" (JOINTED)
- 11 PORTLAND CEMENT CONCRETE SHOULDERS 11½"
- 12 TIE BARS PER STANDARD 420001-10 (INCLUDED IN THE COST OF PCC PAVEMENT, PCC BASE COURSE AND PCC SHOULDERS OF THICKNESS SPECIFIED) SEE JOINTING PLANS FOR ADDITIONAL INFORMATION
- 13 CONCRETE BARRIER, DOUBLE FACE, 44 INCH HEIGHT W/ HOOK BARS
- 14 CONCRETE BARRIER, VARIABLE CROSS SECTION 44 INCH HEIGHT W/ HOOK BARS
- 15 CONCRETE BARRIER, SINGLE FACE, 44 INCH HEIGHT
- 16 CONCRETE BARRIER BASE
- 17 CONCRETE BARRIER BASE (SPECIAL NO. 1)
- 18 CONCRETE BARRIER BASE (SPECIAL NO. 2)
- 19 SHOULDER RUMBLE STRIPS, 16 INCH
- 20 STEEL PLATE BEAM GUARDRAIL, TYPE A, 6 FOOT POSTS
- 21 CONCRETE MEDIAN, TYPE SM-6.24
- 22 COMBINATION CONCRETE CURB & GUTTER, TYPE B-6.24
- 23 NOISE ABATEMENT WALL (SEE PLANS FOR DETAILS)
- 24 CONSTRUCTION JOINT AND DOWEL BARS (INCLUDED IN THE COST OF CRC PAVEMENT) SEE JOINTING DETAILS FOR ADDITIONAL INFORMATION
- 25 CONCRETE GUTTER, TYPE B
- 26 CONCRETE MEDIAN SURFACE, 4"
- 27 CHAIN LINK FENCE, 4"
- 28 AGGREGATE BASE COURSE, TYPE B 6"

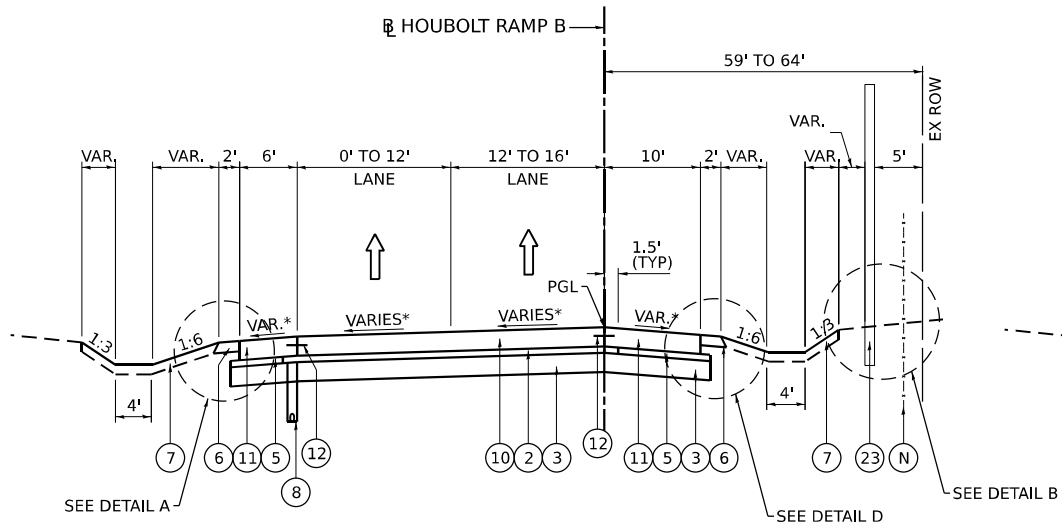

**PROPOSED TYPICAL SECTION**

PR HOUBOLT RAMP B  
STA 303+58.15 TO STA 308+59.91

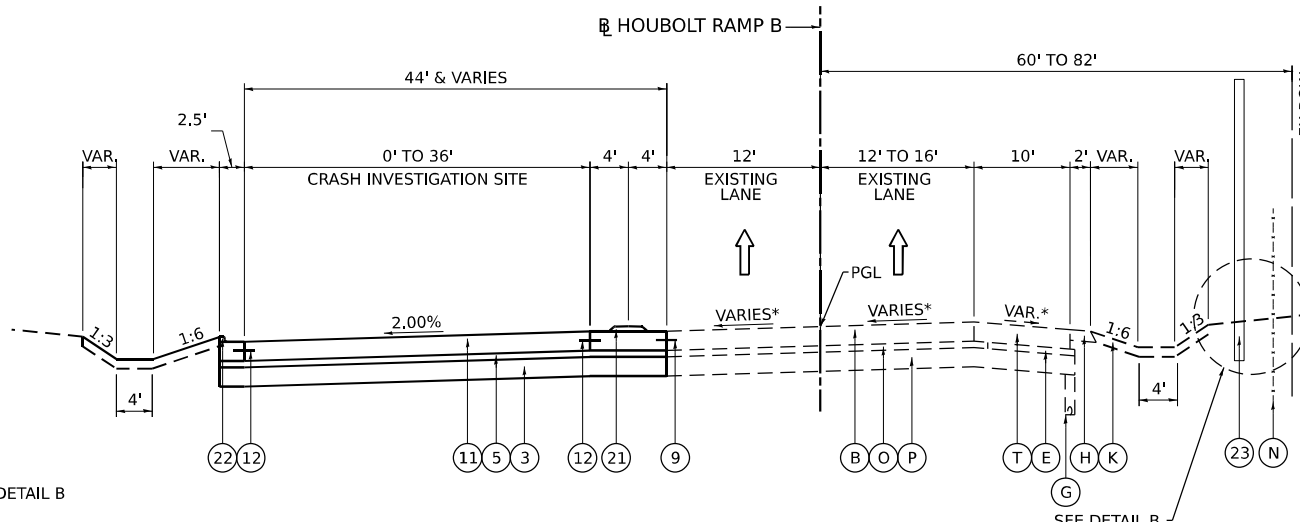

**PROPOSED TYPICAL SECTION**

CRASH INVESTIGATION SITE  
PR HBLT RAMP B STA 308+59.91 TO STA 311+35.00



USER NAME = amkluver	DESIGNED - VLJ	REVISED -
PLOT SCALE = 0.16666633 1/16"	DRAWN - AMK	REVISED -
PLOT DATE = 6/23/2023	CHECKED - JMG	REVISED -
	DATE - 6/26/23	REVISED -

**STATE OF ILLINOIS  
DEPARTMENT OF TRANSPORTATION**

<b>TYPICAL SECTIONS HOUBOLT INTERCHANGE RAMPS</b>			
SCALE: NONE	SHEET 8	OF 11 SHEETS	STA. TO STA.

F.A.I. RTE.	SECTION	COUNTY	TOTAL SHEETS	SHEET NO.
I-80	FAI 80 21 STRUCTURE 6	WILL	898	28
			CONTRACT NO. 62R27	
ILLINOIS FED. AID PROJECT				

MODEL: TYP-08  
 FILE NAME: pr:\transys\transys\comp\pwr\hatched\Documents\Projects\_2018\CH401180022\02-Transys\State\CAD\62R27\Figures\03-Typ\_Sec\0162R27-SHT-TYPICAL

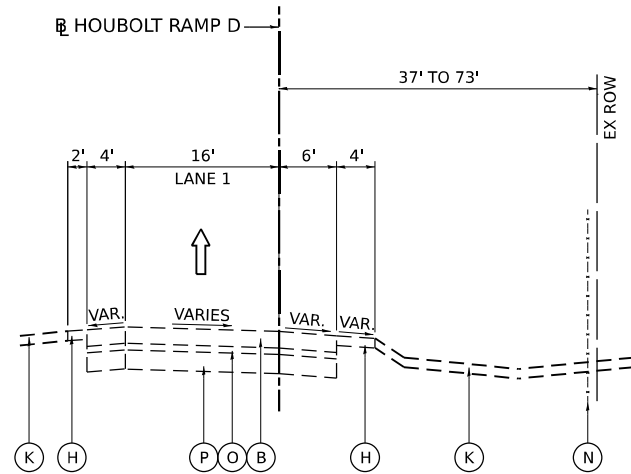

**EXISTING TYPICAL SECTION**

EX HOUBOLT RAMP D  
STA 400+00.00 TO STA 402+99.85

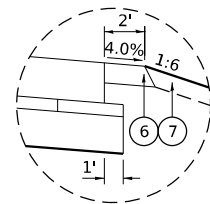

**DETAIL A**

AGGREGATE SHOULDER  
ALL TYPICAL SECTIONS

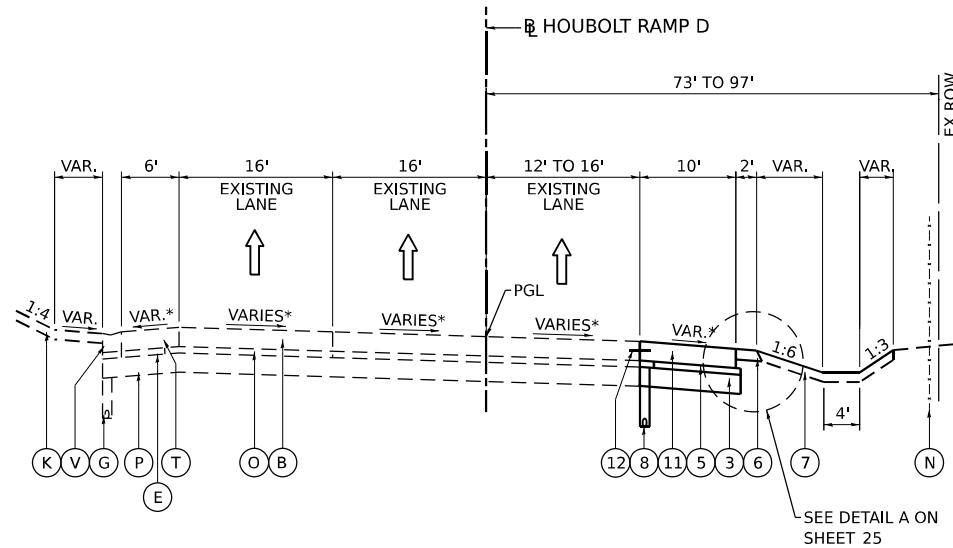

**PROPOSED TYPICAL SECTION**

PR HOUBOLT RAMP D SHOULDER  
STA 106+50.00 TO STA 108+22.43

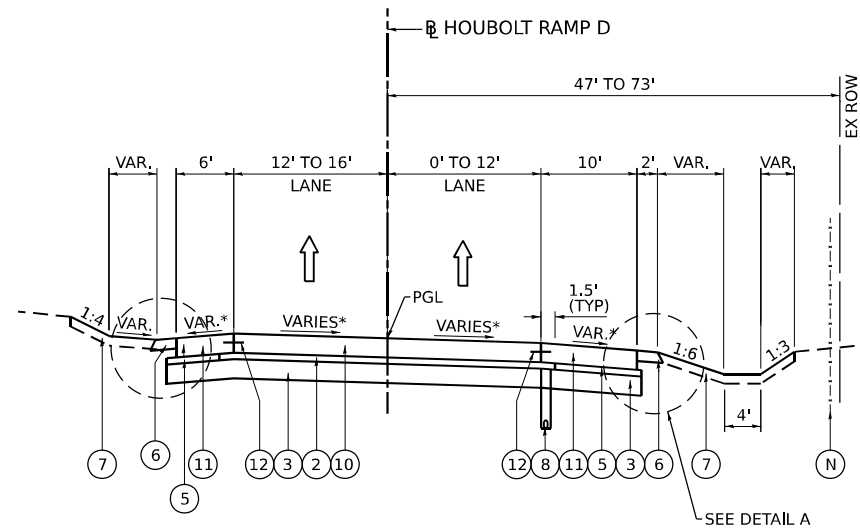

**PROPOSED TYPICAL SECTION**

PR HOUBOLT RAMP D  
STA 103+49.94 TO STA 106+50.00

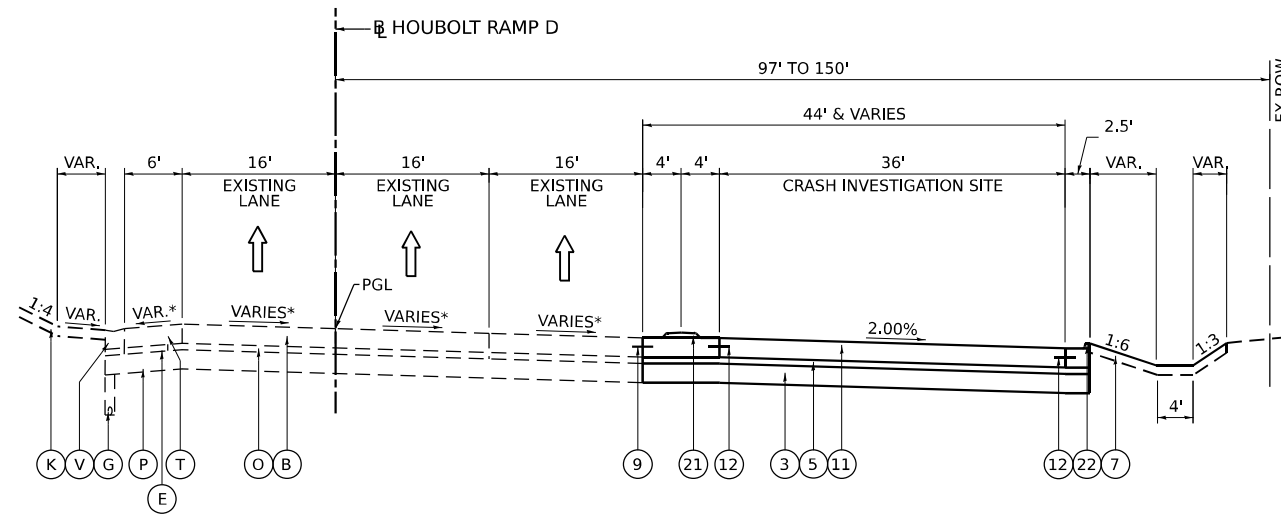

**PROPOSED TYPICAL SECTION**

CRASH INVESTIGATION SITE  
PR HBLT RAMP D STA 108+22.43 TO STA 111+77.13

**EXISTING**

- (A) CONTINUOUSLY REINFORCED CONCRETE PAVEMENT, 8" AND VARIES
- (B) PORTLAND CEMENT CONCRETE PAVEMENT (10" AND VARIES)
- (C) STONE MATRIX ASPHALT, SURFACE COURSE, 2"
- (D) STONE MATRIX ASPHALT, BINDER COURSE, 2"
- (E) SUBBASE GRANULAR MATERIAL, 6"
- (F) HOT-MIX ASPHALT SHOULDER, 8"
- (G) PIPE UNDERDRAIN
- (H) AGGREGATE SHOULDER
- (I) EXISTING 3" HOT-MIX ASPHALT OVERLAY
- (J) BITUMINOUS CONCRETE SURFACE COURSE, SUPERPAVE MIX "C" N50, 2"
- (K) GROUND SURFACE (ASSUMED EXISTING 6" TOPSOIL DEPTH)
- (L) GUARDRAIL
- (M) CABLE BARRIER
- (N) EXISTING FENCE
- (O) STABILIZED SUBBASE (4" AND VARIES)
- (P) AGGREGATE SUBGRADE (12" AND VARIES)
- (Q) BIT. CONC. SURFACE CSE., MIX E, CLASS 1, TY. 2, 2"
- (R) BIT. CONC. BINDER CSE., MIX B, TY. 2, 1.5"
- (S) BITUMINOUS SHOULDER, 10"
- (T) PORTLAND CEMENT CONCRETE SHOULDER, 10"
- (U) BRIDGE PIER

**NOTES:**

1. THE MAXIMUM ROLLOVER BETWEEN THE PAVEMENT AND THE SHOULDER ON THE HIGH SIDE OF THE SUPERELEVATION IS 8%.
2. FOR CONTINUOUSLY REINFORCED PORTLAND CEMENT CONCRETE PAVEMENT (JOINTED) DETAILS SEE JOINTING AND SUPERELEVATION PLAN.
- \* 3. SEE SUPER ELEVATION SHEETS 86 TO 87 FOR TRANSITION CROSS SLOPE INFORMATION.

**PROPOSED**

- (1) CONTINUOUSLY REINFORCED PORTLAND CEMENT CONCRETE PAVEMENT 13"
- (2) STABILIZED SUBBASE - HOT-MIX ASPHALT, 4"
- (3) AGGREGATE SUBGRADE IMPROVEMENT 12"
- (4) PORTLAND CEMENT CONCRETE SHOULDERS 13"
- (5) SUBBASE GRANULAR MATERIAL, TYPE C 4"
- (6) AGGREGATE SHOULDERS, TYPE B 6" (SEE DETAIL A)
- (7) TOPSOIL EXCAVATION AND PLACEMENT AND SEEDING (SEE LANDSCAPING PLANS FOR DETAILS AND PAY ITEMS)
- (8) PIPE UNDERDRAINS, TYPE 2, 6"
- (9) DRILL AND GROUT TIE BARS PER STANDARD 420001-10 (INCLUDED IN THE COST OF CONCRETE MEDIAN AND PCC SHOULDERS OF THICKNESS SPECIFIED)
- (10) PORTLAND CEMENT CONCRETE PAVEMENT 11 1/2" (JOINTED)
- (11) PORTLAND CEMENT CONCRETE SHOULDERS 11 1/2"
- (12) TIE BARS PER STANDARD 420001-10 (INCLUDED IN THE COST OF PCC PAVEMENT, PCC BASE COURSE AND PCC SHOULDERS OF THICKNESS SPECIFIED) SEE JOINTING PLANS FOR ADDITIONAL INFORMATION
- (13) CONCRETE BARRIER, DOUBLE FACE, 44 INCH HEIGHT W/ HOOK BARS
- (14) CONCRETE BARRIER, VARIABLE CROSS SECTION 44 INCH HEIGHT W/ HOOK BARS
- (15) CONCRETE BARRIER, SINGLE FACE, 44 INCH HEIGHT
- (16) CONCRETE BARRIER BASE
- (17) CONCRETE BARRIER BASE (SPECIAL NO. 1)
- (18) CONCRETE BARRIER BASE (SPECIAL NO. 2)
- (19) SHOULDER RUMBLE STRIPS, 16 INCH
- (20) STEEL PLATE BEAM GUARDRAIL, TYPE A, 6 FOOT POSTS
- (21) CONCRETE MEDIAN, TYPE SM-6.24
- (22) COMBINATION CONCRETE CURB & GUTTER, TYPE B-6.24
- (23) NOISE ABATEMENT WALL (SEE PLANS FOR DETAILS)
- (24) CONSTRUCTION JOINT AND DOWEL BARS (INCLUDED IN THE COST OF CRC PAVEMENT) SEE JOINTING DETAILS FOR ADDITIONAL INFORMATION
- (25) CONCRETE GUTTER, TYPE B
- (26) CONCRETE MEDIAN SURFACE, 4"
- (27) CHAIN LINK FENCE, 4"
- (28) AGGREGATE BASE COURSE, TYPE B 6"

### AGGREGATE SUBGRADE IMPROVEMENT

ALIGNMENT	START STATION	END STATION	OFFSET LEFT	OFFSET RIGHT	DEPTH (IN)	AREA (SQ FT)	AGGREGATE SUBGRADE IMPROVEMENT (CU YD)	GEOTECHNICAL FABRIC FOR GROUND STABILIZATION (SQ YD)
I-80 WB	412+00	416+50	84.50' LT	0.00' RT	12	35,733	1,323	4,089
CULVERT SN 099-0760 - STRUCTURAL								491
I-80	422+50	424+50	EXISTING MEDIAN		36	10,757	1,195	1,365
I-80	500+70	502+70	EXISTING MEDIAN		24	9,121	676	1,123
I-80 EB	514+60	516+70	63.70' LT	0.00' RT	12	12,871	477	1,491
ALLOWANCE FOR OTHER AREAS (25% OF TOTAL PAVEMENT AREA ASSUMED)							8,911	27,085
						<b>TOTAL</b>	<b>12,582</b>	<b>35,644</b>

### **NOTES:**

1. AGGREGATE SUBGRADE IMPROVEMENT (CU YD) SHALL BE USED TO REPLACE ANY UNSUITABLE SOILS BELOW THE BOTTOM OF THE IMPROVED SUBGRADE LAYER THAT ARE ENCOUNTERED IN THE FIELD DURING CONSTRUCTION. THE NEED FOR REMOVAL AND REPLACEMENT SHALL BE DETERMINED BY THE GEOTECHNICAL ENGINEER OR SOILS INSPECTOR. ALL POTENTIALLY UNSTABLE SOILS SHALL BE TESTED WITH A CONE PENETROMETER AND TREATED IN ACCORDANCE WITH ARTICLE 301.04 OF THE SSRBC AND THE UNDERCUT GUIDELINES IN THE IDOT SUBGRADE STABILITY MANUAL. ANY MATERIAL NOT NEEDED FOR UNDERCUT REPLACEMENT AT THE TIME OF CONSTRUCTION SHALL BE DELETED FROM THE CONTRACT WITH NO EXTRA COMPENSATION TO THE CONTRACTOR.
2. THE SUBGRADE STABILITY SHALL BE VERIFIED BY PROOF ROLLING WITH A FULLY LOADED TANDEM-AXLE TRUCK.
3. GEOTECHNICAL FABRIC FOR GROUND STABILIZATION AND/OR AGGREGATE SUBGRADE IMPROVEMENT (CU YD) HAVE BEEN PROVIDED FOR USE AT LOCATIONS INDICATED FOR SOILS THAT TEND TO BE UNSTABLE AND/OR UNSUITABLE. THE ACTUAL NEED FOR REMOVAL AND REPLACEMENT WITH ABOVE ITEM WILL BE DETERMINED IN THE FIELD AT THE TIME OF CONSTRUCTION BY THE GEOTECHNICAL ENGINEER. ALL POTENTIALLY UNSTABLE SOILS SHOULD BE TESTED WITH A STATIC OR DYNAMIC CONE PENETROMETER AND TREATED IN ACCORDANCE WITH ARTICLE 301.04 OF THE SSRBC AND IDOT SUBGRADE STABILITY MANUAL. IF UNSTABLE AND/OR UNSUITABLE SOILS ARE NOT ENCOUNTERED, THEN THE QUANTITY SHALL BE DEDUCTED AND NO ADDITIONAL COMPENSATION WILL BE DUE TO THE CONTRACTOR.
4. ANY AGGREGATE SUBGRADE IMPROVEMENT CONTAMINATED AND/OR DAMAGED BY THE CONTRACTOR'S VEHICLES AND/OR EQUIPMENT IS TO BE REMOVED AND REPLACED AS DIRECTED BY THE ENGINEER AT THE CONTRACTOR'S EXPENSE.
5. THE AGGREGATE GRADATION FOR THE AGGREGATE SUBGRADE IMPROVEMENT 12" LOWER LIFT SHALL BE CS 1 OR RR1.

MODEL: TYP-20  
 FILE NAME: p:\transystems\pww\transystems\comp\pw\checked\Documents\Projects\_2018\CI-401\401180022\02-TransSystems\CAD\62R27\62R27-Sheet-03.dwg\_Sec0162R27-S5-T-TYPICAL



USER NAME = amkluver	DESIGNED - VLJ	REVISED -
	DRAWN - AMK	REVISED -
PLOT SCALE = 0.16666633 1/ in.	CHECKED - JMG	REVISED -
PLOT DATE = 8/10/2023	DATE - 8/10/2023	REVISED -

**STATE OF ILLINOIS  
DEPARTMENT OF TRANSPORTATION**

**TYPICAL SECTIONS  
TEMPORARY PAVEMENT DETAILS AND HMA TABLE**

SCALE: SHEET 10 OF 11 SHEETS STA. TO STA.

F.A.I. RTE.	SECTION	COUNTY	TOTAL SHEETS	SHEET NO.
I-80	FAI 80 21 STRUCTURE 6	WILL	898	30
CONTRACT NO. 62R27				
ILLINOIS FED. AID PROJECT				



**TEMPORARY PAVEMENT DETAILS:**

**DETAIL A: FULL DEPTH TEMPORARY HMA PAVEMENT**

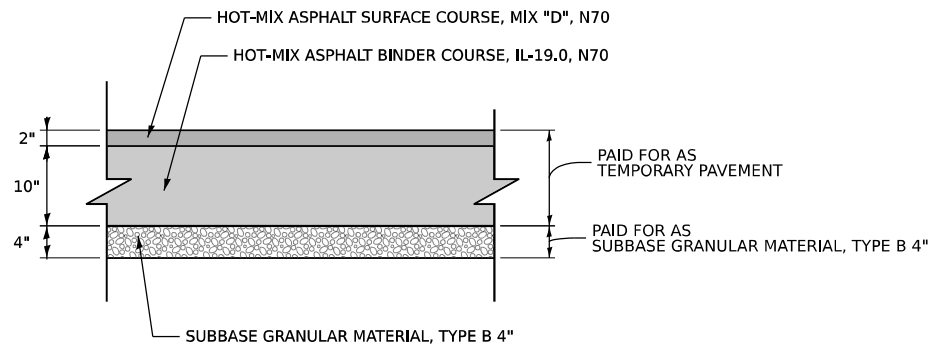

**TEMPORARY HMA PAVEMENT FOR RAMPS**

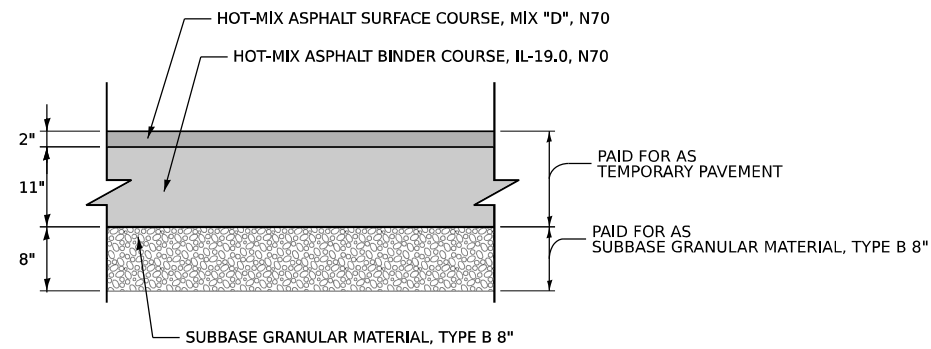

**TEMPORARY HMA PAVEMENT FOR I-80**

**DETAIL B: TEMPORARY PCC PAVEMENT**

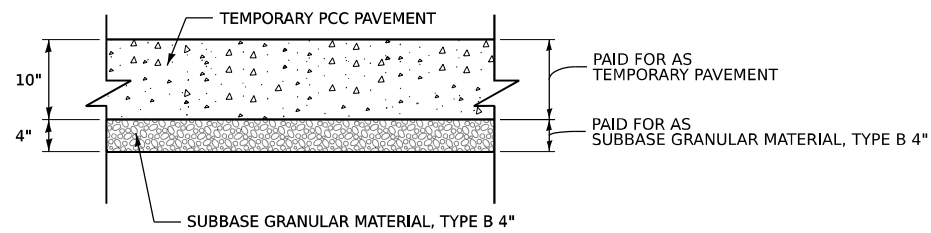

**TEMPORARY PCC PAVEMENT FOR RAMPS**

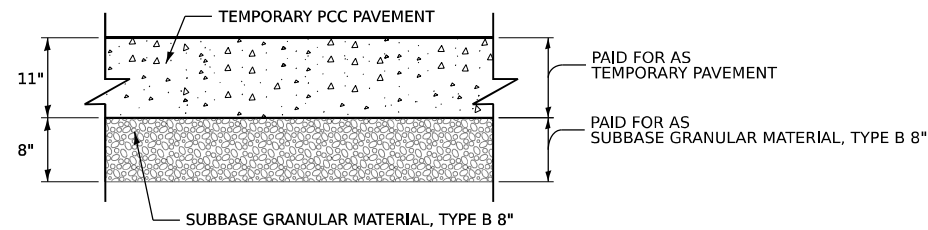

**TEMPORARY PCC PAVEMENT FOR I-80**

**HOT MIX ASPHALT MIXTURE REQUIREMENTS**

MIXTURE TYPE	AIR VOIDS (%) @NDES	QMP
PAVEMENT RECONSTRUCTION		
I-80 & RAMPS		
STABILIZED SUBBASE - HOT-MIX ASPHALT, 4" (HMA BINDER IL-19.0)	3% @ 50 GYR	QC/QA
TEMPORARY PAVEMENT (IF HMA OPTION IS SELECTED BY CONTRACTOR)		
I-80		
HOT-MIX ASPHALT SURFACE COURSE, MIX "D", N70, (IL-9.5 MM): 2"	4% @ 70 GYR	QC/QA
HOT-MIX ASPHALT BINDER COURSE, IL-19.0, N70: 11"	4% @ 70 GYR	QC/QA
RAMPS		
HOT-MIX ASPHALT SURFACE COURSE, MIX "D", N70, (IL-9.5 MM): 2"	4% @ 70 GYR	QC/QA
HOT-MIX ASPHALT BINDER COURSE, IL-19.0, N70: 10"	4% @ 70 GYR	QC/QA
SHOULDER RESURFACING		
HOT-MIX ASPHALT SURFACE COURSE, IL-9.5, MIX "D", N70: 2"	4% @ 70 GYR	QC/QA
QMP DESIGNATION: QUALITY CONTROL/QUALITY ASSURANCE (QC/QA); QUALITY CONTROL FOR PERFORMANCE (QCP)		

1. THE UNIT WEIGHT USED TO CALCULATE ALL HMA SURFACE MIXTURE QUANTITIES IS 112 LBS/SQ YD/IN.
2. THE "AC TYPE" FOR POLYMERIZED HMA MIXTURES SHALL BE "SBS/SBR PG 76-22" AND FOR NON-POLYMERIZED HMA THE AC TYPE SHALL BE "PG 64-22", UNLESS MODIFIED BY RECLAIMED MATERIALS SPECIFICATIONS.

**TEMPORARY PAVEMENT GENERAL NOTES**

1. THE CONTRACTOR SHALL HAVE THE OPTION OF USING HMA OR PCC SECTION FOR TEMPORARY PAVEMENT, UNLESS OTHERWISE SHOWN ON THE PLANS.
2. TEMPORARY HMA PAVEMENT SHALL CONSIST OF TWO ITEMS: HMA BINDER COURSE AND HMA SURFACE COURSE.
3. PORTLAND CEMENT CONCRETE TEMPORARY PAVEMENT SHALL CONSIST OF CLASS PV CONCRETE MEETING THE REQUIREMENTS OF ARTICLE 1020 OF THE STANDARD SPECIFICATIONS. TEMPORARY PCC PAVEMENT DOES NOT REQUIRE DOWEL BARS.

MODEL: TYP-11  
 FILE NAME: p:\transystems\ppl\ben\by.com\transystems\comp\ppl\hosed\Documents\Projects\_2018\CI-401\401180022\02-TransSystems\CAD\62R27\Sheets\03-Typ\_Sec\02R27-SHT-TYPICAL

**TRANSYSTEMS**

USER NAME = amkluver	DESIGNED - VLJ	REVISED -
PLOT SCALE = 0.16666633 1/ in.	DRAWN - AMK	REVISED -
PLOT DATE = 7/27/2023	CHECKED - JMG	REVISED -
	DATE - 6/26/23	REVISED -

**STATE OF ILLINOIS  
DEPARTMENT OF TRANSPORTATION**

**TYPICAL SECTIONS  
TEMPORARY PAVEMENT DETAILS AND HMA TABLE**

SCALE: NONE SHEET 11 OF 11 SHEETS STA. TO STA.

F.A.I. RTE.	SECTION	COUNTY	TOTAL SHEETS	SHEET NO.
I-80	FAI 80 21 STRUCTURE 6	WILL	898	31
				CONTRACT NO. 62R27
		ILLINOIS	FED. AID PROJECT	

# REMOVAL SCHEDULE

LOCATION	TREE REMOVAL (6 TO 15 UNITS DIAMETER)	TREE REMOVAL (OVER 15 UNITS DIAMETER)	TREE REMOVAL, ACRES	TREE TRUNK PROTECTION	TREE ROOT PRUNING	TREE PRUNING (1 TO 10 INCH DIAMETER)	TREE PRUNING (OVER 10 INCH DIAMETER)	PAVEMENT REMOVAL	PAVED DITCH REMOVAL	PAVED SHOULDER REMOVAL	GUARDRAIL REMOVAL	HIGH TENSION CABLE MEDIAN BARRIER REMOVAL	TREE REMOVAL, ACRES (SPECIAL)	LUG SYSTEM REMOVAL	APPROACH SLAB REMOVAL	FENCE REMOVAL
	UNIT	UNIT	ACRE	EACH	EACH	EACH	EACH	SQ YD	FOOT	SQ YD	FOOT	FOOT	ACRE	EACH	SQ YD	FOOT
STATION 410+00 TO STATION 417+00	24	78	1.00	-	1	-	-	3,890	-	2,099	356	787	-	-	-	1,402
STATION 417+00 TO STATION 429+00	40	37	0.75	-	1	-	-	7,618	-	3,493	1,503	698	0.25	-	-	2,402
STATION 429+00 TO STATION 441+00	295	90	0.25	1	1	4	-	11,265	-	6,993	1,179	1,205	0.25	-	-	2,162
STATION 441+00 TO STATION 453+00	68	-	0.50	-	-	-	-	6,240	-	4,466	1,115	909	-	12	579	536
STATION 453+00 TO STATION 465+00	6	51	0.25	1	1	8	-	10,221	-	4,746	1,182	1,200	0.25	-	-	1,921
STATION 465+00 TO STATION 477+00	59	78	0.75	1	1	-	28	6,867	-	4,056	716	489	0.50	-	-	2,333
STATION 477+00 TO STATION 489+00	36	66	1.25	1	1	-	24	6,721	-	3,522	102	1,099	0.25	-	-	2,102
STATION 489+00 TO STATION 501+00	43	32	1.00	-	1	-	-	6,724	14	3,460	731	874	0.25	-	-	1,981
STATION 501+00 TO STATION 513+00	9	-	1.00	4	1	20	11	6,780	-	3,402	-	1,203	-	-	-	1,468
STATION 513+00 TO STATION 518+00	-	49	0.50	-	-	-	-	2,819	-	1,435	-	502	-	-	-	850
<b>TOTAL</b>	<b>580</b>	<b>481</b>	<b>7.25</b>	<b>8</b>	<b>8</b>	<b>32</b>	<b>63</b>	<b>69,145</b>	<b>14</b>	<b>37,672</b>	<b>6,884</b>	<b>8,966</b>	<b>1.75</b>	<b>12</b>	<b>579</b>	<b>17,157</b>

MODEL: SCH-01  
 FILE NAME: p:\transystems\pw\beetby.com\transystems\comp\pw\_hosted\Documents\Projects\_2018\CH-401\401180022\02-TransSystems\CAD\62R27\62R27\62R27-SHT-SCHEDULES.dgn



USER NAME = amkluver	DESIGNED - VLJ	REVISED -
PLOT SCALE = 0.16666633 1/16 in.	DRAWN - AMK	REVISED -
PLOT DATE = 6/23/2023	CHECKED - JMG	REVISED -
	DATE - 6/26/23	REVISED -

**STATE OF ILLINOIS  
DEPARTMENT OF TRANSPORTATION**

**SCHEDULE OF QUANTITIES**

SCALE: NONE      SHEET 1 OF 3 SHEETS      STA.      TO STA.

F.A.I. RTE.	SECTION	COUNTY	TOTAL SHEETS	SHEET NO.
I-80	FAI 80 21 STRUCTURE 6	WILL	898	32
			CONTRACT NO. 62R27	
		ILLINOIS	FED. AID PROJECT	

# ROADWAY SCHEDULE

LOCATION	AGGREGATE SUBGRADE IMPROVEMENT 12"	SUBBASE GRANULAR MATERIAL, TYPE C 4"	STABILIZED SUBBASE - HOT-MIX ASPHALT, 4"	AGGREGATE BASE COURSE, TYPE B 6"	PAVEMENT CONNECTOR (PCC) FOR BRIDGE APPROACH SLAB	PORTLAND CEMENT CONCRETE PAVEMENT 11 1/2" (JOINTED)	PROTECTIVE COAT	CONTINUOUSLY REINFORCED PORTLAND CEMENT CONCRETE PAVEMENT 13"	PAVEMENT REINFORCEMENT	LUG SYSTEM COMPLETE 36'	AGGREGATE SHOULDERS, TYPE B 6"	PORTLAND CEMENT CONCRETE SHOULDERS 11 1/2"	PORTLAND CEMENT CONCRETE SHOULDERS 13"	COMBINATION CONCRETE CURB AND GUTTER, TYPE B-6.24	CONCRETE GUTTER, TYPE B	CONCRETE MEDIAN SURFACE, 4 INCH	CONCRETE MEDIAN, TYPE SM-6.24	STEEL PLATE BEAM GUARDRAIL, TYPE A, 6 FOOT POSTS	TRAFFIC BARRIER TERMINAL, TYPE 2	TRAFFIC BARRIER TERMINAL, TYPE 5	TRAFFIC BARRIER TERMINAL, TYPE 6	TRAFFIC BARRIER TERMINAL, TYPE 1 (SPECIAL) TANGENT	DELINEATORS	CONCRETE BARRIER, SINGLE FACE, 44 INCH HEIGHT	CONCRETE BARRIER, DOUBLE FACE, 44 INCH HEIGHT
	SQ YD	SQ YD	SQ YD	SQ YD	SQ YD	SQ YD	SQ YD	SQ YD	SQ YD	EACH	SQ YD	SQ YD	SQ YD	FOOT	FOOT	SQ FT	SQ FT	FOOT	EACH	EACH	EACH	EACH	EACH	FOOT	FOOT
STATION 410+00 TO STATION 417+00	11,977	1,647	9,955	-	-	-	176,014	7,855	7,855	-	390	-	3,734	-	-	-	-	293	2	-	-	-	4	-	640
STATION 417+00 TO STATION 429+00	21,489	2,932	18,023	-	-	30	-	14,392	14,392	-	841	16	6,387	-	-	-	-	1,320	-	-	-	1	-	-	1,100
STATION 429+00 TO STATION 441+00	26,826	6,461	19,793	-	-	5,227	-	10,396	10,396	-	1,567	3,923	6,279	284	-	-	54	1,822	2	-	-	3	23	-	935
STATION 441+00 TO STATION 453+00	15,248	4,327	10,523	-	310	705	-	6,755	6,755	4	1,034	1,143	5,949	500	471	-	54	1,142	2	2	2	-	19	-	302
STATION 453+00 TO STATION 465+00	21,021	2,769	17,537	366	-	1,962	-	11,612	11,612	-	910	887	5,554	-	203	366	-	488	-	-	1	2	17	440	1,100
STATION 465+00 TO STATION 477+00	18,033	1,375	16,068	10	-	-	-	12,468	12,468	-	489	-	4,797	-	475	10	-	-	-	-	-	-	6	200	1,100
STATION 477+00 TO STATION 489+00	16,785	2,889	13,245	342	-	-	-	9,645	9,645	-	830	-	6,265	-	1,087	342	-	75	-	-	1	1	5	410	1,120
STATION 489+00 TO STATION 501+00	16,667	3,195	13,119	-	-	-	-	9,600	9,600	-	828	-	5,720	-	1,050	-	-	13	-	-	1	1	5	-	1,100
STATION 501+00 TO STATION 513+00	16,667	2,934	13,200	-	-	-	-	9,600	9,600	-	973	-	6,400	-	1,216	-	-	-	-	-	-	-	6	-	1,103
STATION 513+00 TO STATION 518+00	6,513	1,223	5,068	-	-	-	-	3,568	3,568	2	400	-	2,667	-	489	-	-	-	-	-	-	-	4	-	477
<b>TOTAL</b>	<b>171,226</b>	<b>29,752</b>	<b>136,531</b>	<b>718</b>	<b>310</b>	<b>7,924</b>	<b>176,014</b>	<b>95,891</b>	<b>95,891</b>	<b>6</b>	<b>8,262</b>	<b>5,969</b>	<b>53,752</b>	<b>784</b>	<b>4,991</b>	<b>718</b>	<b>108</b>	<b>5,153</b>	<b>6</b>	<b>2</b>	<b>5</b>	<b>8</b>	<b>89</b>	<b>1,050</b>	<b>8,977</b>

LOCATION	CONCRETE BARRIER, VARIABLE CROSS SECTION 44 INCH HEIGHT	CONCRETE BARRIER BASE	CHAIN LINK FENCE, 4'	CHAIN LINK GATES, 4' X 4' SINGLE	TERMINAL MARKER - DIRECT APPLIED	GUARDRAIL REFLECTORS, TYPE A	BARRIER WALL REFLECTORS, TYPE C	CONCRETE BARRIER BASE (SPECIAL NO. 1)	CONCRETE BARRIER BASE (SPECIAL NO. 2)
	FOOT	FOOT	FOOT	EACH	EACH	EACH	EACH	FOOT	FOOT
STATION 410+00 TO STATION 417+00	-	640	1,402	-	-	6	8	-	-
STATION 417+00 TO STATION 429+00	-	1,100	2,402	-	1	15	12	-	-
STATION 429+00 TO STATION 441+00	166	935	2,543	-	3	26	12	166	-
STATION 441+00 TO STATION 453+00	615	302	206	1	-	15	12	615	-
STATION 453+00 TO STATION 465+00	-	1,100	2,213	1	2	8	24	-	440
STATION 465+00 TO STATION 477+00	-	1,100	2,408	-	-	-	14	-	200
STATION 477+00 TO STATION 489+00	-	1,120	1,423	1	1	4	22	-	410
STATION 489+00 TO STATION 501+00	-	1,100	1,427	2	1	4	22	-	-
STATION 501+00 TO STATION 513+00	-	1,103	1,185	-	-	-	12	-	-
STATION 513+00 TO STATION 518+00	-	477	494	-	-	-	8	-	-
<b>TOTAL</b>	<b>781</b>	<b>8,977</b>	<b>15,703</b>	<b>5</b>	<b>8</b>	<b>78</b>	<b>146</b>	<b>781</b>	<b>1,050</b>

MODEL: SCH-403  
 FILE NAME: p:\transys\transyscomp\pw\_bentley\comtransyscomp\pw\_bentley\Documents\Projects\_2018\CH-401\401180022\02-TransSystems\CAD\62R27\Sheet\03-Schedule\03-Schedule.dgn



USER NAME = amkluver	DESIGNED - VLJ	REVISED -
PLOT SCALE = 0.16666633 1/16 in.	DRAWN - AMK	REVISED -
PLOT DATE = 7/27/2023	CHECKED - JMG	REVISED -
	DATE - 6/26/23	REVISED -

**STATE OF ILLINOIS  
DEPARTMENT OF TRANSPORTATION**

<b>SCHEDULE OF QUANTITIES</b>			
SCALE: NONE	SHEET 2	OF 3 SHEETS	STA. TO STA.

F.A.I. RTE.	SECTION	COUNTY	TOTAL SHEETS	SHEET NO.
I-80	FAI 80 21 STRUCTURE 6	WILL	898	33
			CONTRACT NO. 62R27	
		ILLINOIS	FED. AID PROJECT	

# EARTHWORK SCHEDULE

EARTHWORK SUMMARY OF QUANTITIES												
PROJECT AREA	EARTH EXCAVATION	EARTH EXCAVATION (ADJUSTED 15% FOR SHRINKAGE) (SEE NOTE 1)	ROCK EXCAVATION (SEE NOTE 7)	EMBANKMENT (SEE NOTE 1)	EARTHWORK BALANCE WASTE (+), SHORTAGE (-) (SEE NOTE 1)	FURNISHED EXCAVATION	TOPSOIL EXCAVATION AND PLACEMENT (SEE NOTE 2)	TOPSOIL PLACEMENT (SEE NOTE 1)	TOPSOIL BALANCE WASTE (+) OR SHORTAGE (-) (SEE NOTE 1 & 5)	TOPSOIL FURNISH AND PLACE, (4")	AGGREGATE SUBGRADE IMPROVEMENT	REMOVAL AND DISPOSAL OF UNSUITABLE MATERIAL
	CU YD	CU YD		CU YD	CU YD	CU YD	CU YD	CU YD	CU YD	SY	CU YD	CU YD (UNDERCUT)
PRE-STAGE	6,818	5,795		19,876	-14,081	14,081	8,536	0	8,536	0		
STAGE 1 - MAINLINE	19,658	16,709		18,036	-1,327	1,327	15,807	0	15,807	0		
STAGE 2 - MAINLINE	77,497	65,872	205	8,523	57,349	0	13,092	17,478	-4,386	39,476		
STAGE 2 - RAMP A HOUBOLT RD INTERCHANGE	4,341	3,690		292	3,398	0						
STAGE 2 - RAMP B HOUBOLT RD INTERCHANGE	1,011	859		93	766	0						
STAGE 2 - RAMP C HOUBOLT RD INTERCHANGE	454	386		32	354	0						
STAGE 2 - RAMP D HOUBOLT RD INTERCHANGE	1,223	1,040		917	123	0						
STAGE 3 - RAMP B HOUBOLT RD INTERCHANGE	1,757	1,493		669	824	0						
STAGE 3 - RAMP C HOUBOLT RD INTERCHANGE	1,372	1,166		14	1,152	0						
UNDERCUT											12,582	12,582
TOTALS	114,131	97,011	205	48,452	48,559	15,407	37,434			39,476	12,582	12,582
ROUNDED TOTALS	114,135	97,015	205	48,455	48,560	15,410	37,435			39,477	12,582	12,582

## NOTES

- NOT A PAY ITEM
- "TOPSOIL EXCAVATION AND PLACEMENT" WILL BE MEASURED FOR PAYMENT BASED ON THE TOTAL VOLUME OF TOPSOIL EXCAVATED. THE CONTRACTOR SHALL REMOVE AND PROPERLY DISPOSE OF WASTE TOPSOIL FROM THE PROJECT SITE. THE COST TO REMOVE AND DISPOSE OF THIS MATERIAL SHALL BE INCLUDED IN THE BID UNIT PRICE PER CUBIC YARD FOR "TOPSOIL EXCAVATION AND PLACEMENT".
- TOPSOIL BALANCE VALUES ARE INCLUDED FOR INFORMATION PURPOSES ONLY.
- TOPSOIL IS ASSUMED TO HAVE 0% SHRINKAGE AFTER BEING EXCAVATED
- ASSUMED NO TOPSOIL SHOULD BE PLACED FOR INTERIM GRADING DURING PRE-STAGE CONSTRUCTION
- EXISTING DETENTION BASINS AT HOUBOLT ROAD INTERCHANGE SHALL NOT BE USED AS EARTHWORK STOCKPILING SITES.
- ROCK EXCAVATION INCLUDED HERE IS FOR EXCAVATION ASSOCIATED WITH ROADWAY WORK. QUANTITY IS ESTIMATED BASED ON INCLUDED BORING LOGS.
- TOPSOIL QUANTITIES WERE MEASURED CONTRACT WIDE AND NOT BROKEN UP BY RAMP SECTIONS

MODEL: SCH-03  
 FILE NAME: p:\transys\transys\comp\pw\_1\res\doc\Documents\Projects\_2018\CH-401\401180022\02-Trans\Systems\CAD\02R27\02R27\03-Schedule\03-Schedule.dgn

**TRANSYSTEMS**

USER NAME = amkluver	DESIGNED - VLJ	REVISED -
PLOT SCALE = 0.16666633 1/ in.	DRAWN - AMK	REVISED -
PLOT DATE = 8/10/2023	CHECKED - JMG	REVISED -
	DATE - 8/10/2023	REVISED -

**STATE OF ILLINOIS  
DEPARTMENT OF TRANSPORTATION**

**SCHEDULE OF QUANTITIES**

SCALE: NONE      SHEET 3      OF 3      SHEETS      STA.      TO STA.

F.A.I. RTE.	SECTION	COUNTY	TOTAL SHEETS	SHEET NO.
I-80	FAI 80 21 STRUCTURE 6	WILL	898	34
			CONTRACT NO. 62R27	
		ILLINOIS	FED. AID PROJECT	

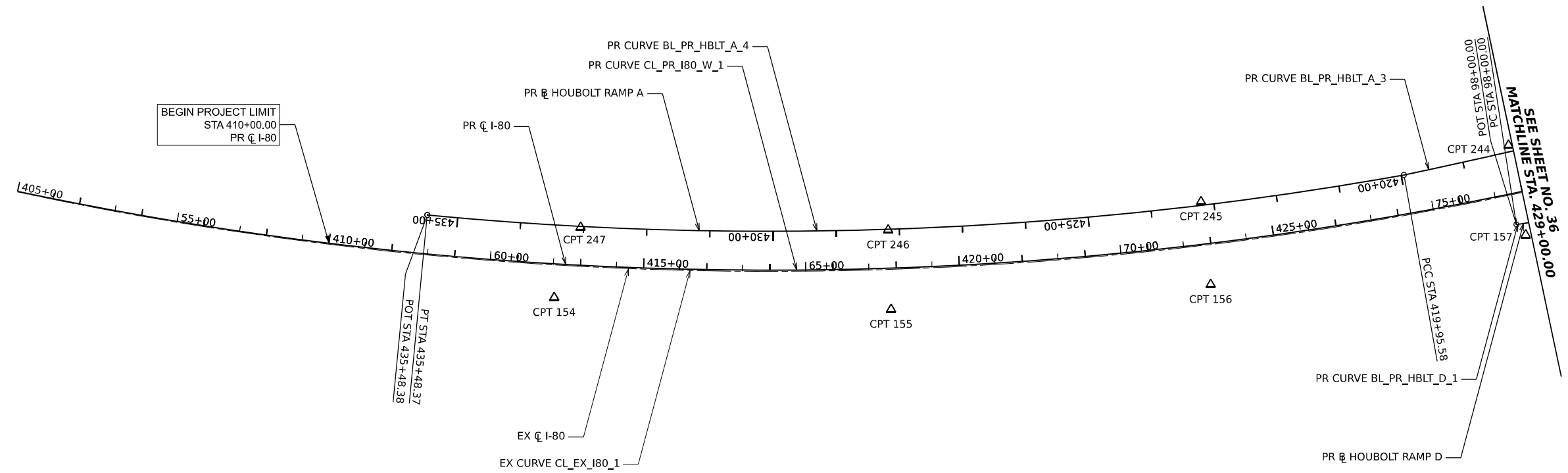
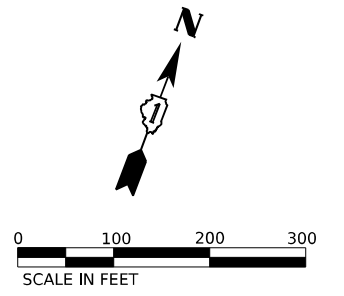

CONTROL POINT INFORMATION

POINT	NORTHING	EASTING	ELEVATION	DESCRIPTION
CPT 154	1755779.004	1027189.502	579.288	MAG NAIL
CPT 155	1755949.610	1027658.282	583.868	MAG NAIL
CPT 156	1756164.769	1028118.088	586.819	MAG NAIL
CPT 157	1756414.469	1028557.058	589.262	CUT CROSS
CPT 244	1756537.639	1028481.435	587.738	CUT CROSS
CPT 245	1756282.120	1028057.492	585.741	CUT CROSS
CPT 246	1756065.493	1027609.560	583.490	MAG NAIL
CPT 247	1755897.841	1027152.280	578.848	MAG NAIL

MODEL: BL\_PR\_I80\_W\_ATB\_1 (Sheet 1)  
 FILE NAME: P:\Projects\2023\62R27\Drawings\CAD\62R27\Drawings\04-Align & Ties\03\62R27-ATB-Sheets.dgn



USER NAME = amkluver	DESIGNED - VLJ	REVISED -
PLOT SCALE = 0.16666633 1/ in.	DRAWN - AMK	REVISED -
PLOT DATE = 6/23/2023	CHECKED - JMG	REVISED -
	DATE - 11/11/22	REVISED -

**STATE OF ILLINOIS  
DEPARTMENT OF TRANSPORTATION**

**ALIGNMENT, TIES AND BENCHMARKS**

SCALE: 1"=100'    SHEET 1    OF 8    SHEETS    STA. 410+00.00    TO STA. 429+00.00

F.A.I. RTE.	SECTION	COUNTY	TOTAL SHEETS	SHEET NO.
I-80	FAI 80 21 STRUCTURE 6	WILL	898	35
CONTRACT NO. 62R27				
ILLINOIS   FED. AID PROJECT				

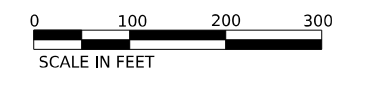
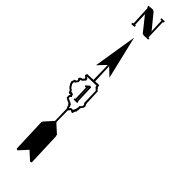

CONTROL POINT INFORMATION

POINT	NORTHING	EASTING	ELEVATION	DESCRIPTION
CPT 158	1756675.331	1028971.089	592.069	CUT CROSS
CPT 159	1757016.517	1029337.733	598.249	CUT CROSS
CPT 160	1757365.979	1029690.536	605.157	CUT CROSS
CPT 161	1757744.823	1030033.785	603.770	CUT CROSS
CPT 240	1757831.372	1029939.804	603.704	CUT CROSS
CPT 241	1757452.898	1029598.207	604.455	CUT CROSS
CPT 242	1757100.133	1029240.580	596.915	CUT CROSS
CPT 243	1756798.401	1028877.542	590.223	CUT CROSS
CPT 1400	1756776.347	1028849.208	590.086	CUT CROSS
CPT 1401	1757148.380	1029004.693	592.648	CUT CROSS
CPT 1402	1757626.078	1029110.117	588.066	CUT CROSS
CPT 1403	1757970.174	1029631.460	583.943	CUT CROSS
CPT 1404	1758105.233	1030004.153	591.663	CUT CROSS
CPT 1406	1757601.944	1030293.975	586.485	MAG NAIL
CPT 1407	1757261.684	1030016.088	578.339	MAG NAIL
CPT 1408	1756971.233	1029518.804	585.140	MAG NAIL
CPT 1409	1758446.821	1029345.590	592.905	MAG NAIL
CPT 1410	1757973.401	1029433.874	589.189	MAG NAIL
CPT 1411	1757558.467	1029633.199	584.561	MAG NAIL
CPT 1412	1757086.294	1029949.352	577.965	MAG NAIL
CPT 1413	1756867.982	1030095.505	571.513	MAG NAIL
CPT 1414	1756925.166	1030137.889	572.051	MAG NAIL
CPT 1415	1757121.963	1030006.432	577.898	MAG NAIL
CPT 1416	1757604.422	1029683.780	583.987	MAG NAIL
CPT 1417	1758002.651	1029497.063	587.746	MAG NAIL
CPT 1418	1758447.755	1029412.596	591.780	MAG NAIL

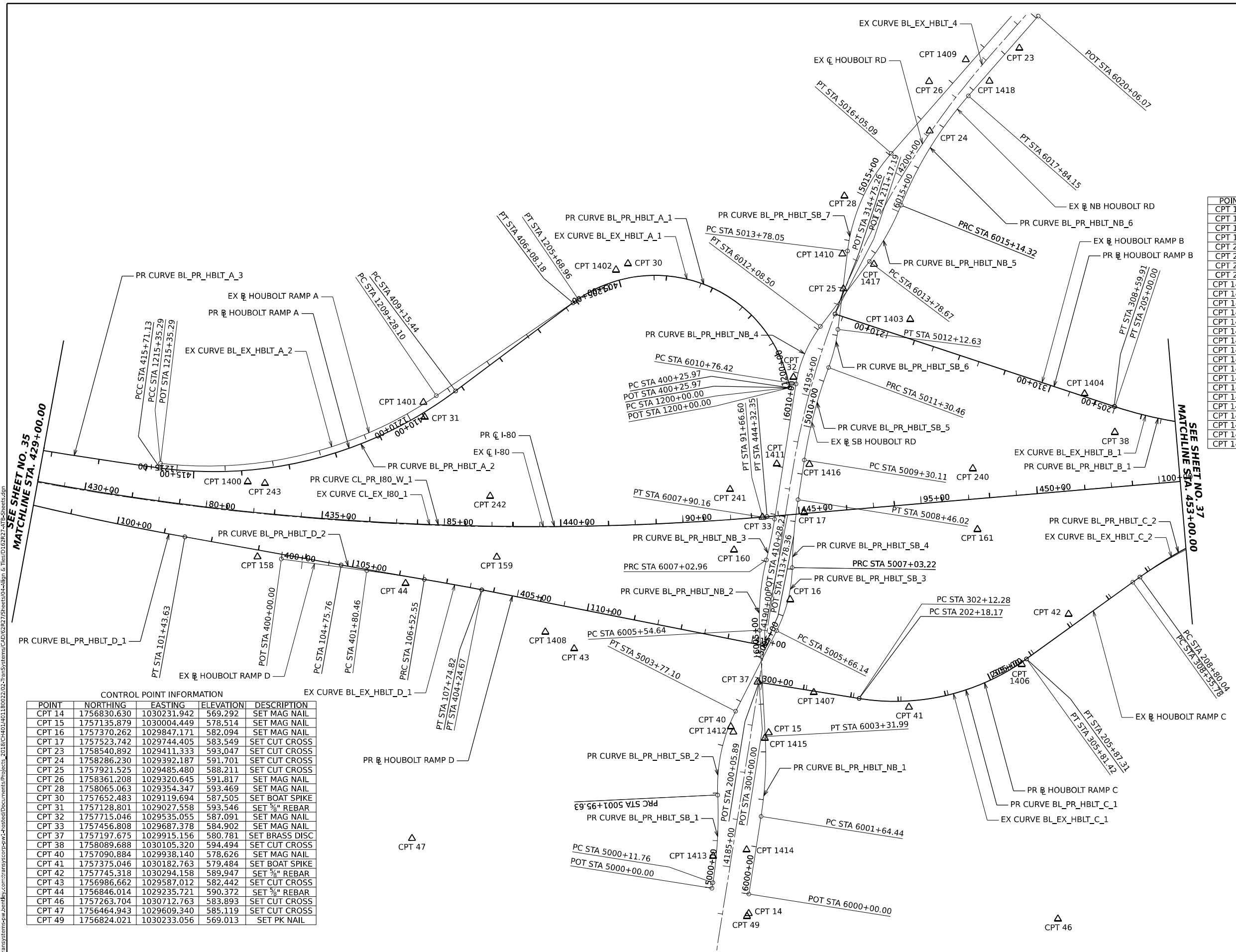

CONTROL POINT INFORMATION

POINT	NORTHING	EASTING	ELEVATION	DESCRIPTION
CPT 14	1756830.630	1030231.942	569.292	SET MAG NAIL
CPT 15	1757135.879	1030004.449	578.514	SET MAG NAIL
CPT 16	1757370.262	1029847.171	582.094	SET MAG NAIL
CPT 17	1757523.742	1029744.405	583.549	SET CUT CROSS
CPT 23	1758540.892	1029411.333	593.047	SET CUT CROSS
CPT 24	1758286.230	1029392.187	591.701	SET CUT CROSS
CPT 25	1757921.525	1029485.480	588.211	SET CUT CROSS
CPT 26	1758361.208	1029320.645	591.817	SET MAG NAIL
CPT 28	1758065.063	1029354.347	593.469	SET MAG NAIL
CPT 30	1757652.483	1029119.694	587.505	SET BOAT SPIKE
CPT 31	1757128.801	1029027.558	593.546	SET 3/4" REBAR
CPT 32	1757715.046	1029535.055	587.091	SET MAG NAIL
CPT 33	1757456.808	1029687.378	584.902	SET MAG NAIL
CPT 37	1757197.675	1029915.156	580.781	SET BRASS DISC
CPT 38	1758089.688	1030105.320	594.494	SET CUT CROSS
CPT 40	1757090.884	1029938.140	578.626	SET MAG NAIL
CPT 41	1757375.046	1030182.763	579.484	SET BOAT SPIKE
CPT 42	1757745.318	1030294.158	589.947	SET 3/4" REBAR
CPT 43	1756986.662	1029587.012	582.442	SET CUT CROSS
CPT 44	1756846.014	1029235.721	590.372	SET 3/4" REBAR
CPT 46	1757263.704	1030712.763	583.893	SET CUT CROSS
CPT 47	1756464.943	1029609.340	585.119	SET CUT CROSS
CPT 49	1756824.021	1030233.056	569.013	SET PK NAIL

MODEL: BL\_PR\_I80\_W\_ATB 2 (Sheet) FILE NAME: P:\Projects\Illinois\2018\20180222\2022\TransSystems\Drawings\2018\20180222\2022\TransSystems\CAD\62R27\62R27.dwg & The\03\62R27\62R27.dwg



USER NAME = amkljuv	DESIGNED - VLJ	REVISED -
PLOT SCALE = 0.16666633 1/ in.	DRAWN - AMK	REVISED -
PLOT DATE = 6/23/2023	CHECKED - JMG	REVISED -
	DATE - 11/11/22	REVISED -

**STATE OF ILLINOIS  
DEPARTMENT OF TRANSPORTATION**

**ALIGNMENT, TIES AND BENCHMARKS**

SCALE: 1"=100'    SHEET 2 OF 8 SHEETS    STA. 429+00.00 TO STA. 453+00.00

F.A.I. RTE.	SECTION	COUNTY	TOTAL SHEETS	SHEET NO.
I-80	FAI 80 21 STRUCTURE 6	WILL	898	36
CONTRACT NO. 62R27				
ILLINOIS		FED. AID PROJECT		

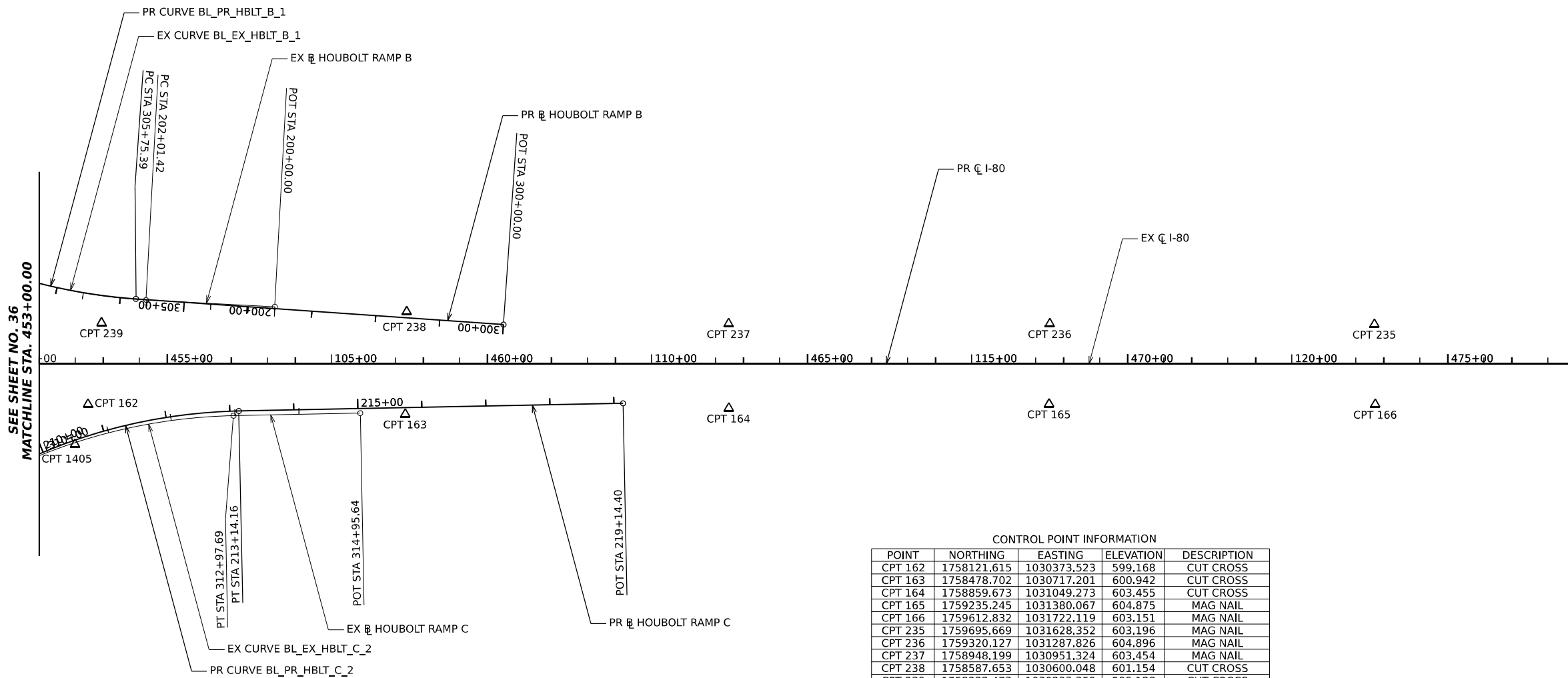
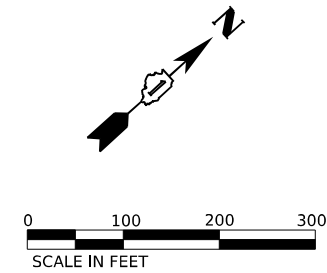

CONTROL POINT INFORMATION

POINT	NORTHING	EASTING	ELEVATION	DESCRIPTION
CPT 162	1758121.615	1030373.523	599.168	CUT CROSS
CPT 163	1758478.702	1030717.201	600.942	CUT CROSS
CPT 164	1758859.673	1031049.273	603.455	CUT CROSS
CPT 165	1759235.245	1031380.067	604.875	MAG NAIL
CPT 166	1759612.832	1031722.119	603.151	MAG NAIL
CPT 235	1759695.669	1031628.352	603.196	MAG NAIL
CPT 236	1759320.127	1031287.826	604.896	MAG NAIL
CPT 237	1758948.199	1030951.324	603.454	MAG NAIL
CPT 238	1758587.653	1030600.048	601.154	CUT CROSS
CPT 239	1758222.473	1030293.359	599.128	CUT CROSS
CPT 1405	1758064.488	1030406.543	597.227	MAG NAIL

MODEL: BL\_PR\_I80\_W-ATB 3 (Sheet)  
 FILE NAME: P:\Projects\2023\62R27\62R27-ATB-Sheets.dgn  
 PROJECT: I-80 Structure 6  
 SHEET: 37  
 DATE: 6/23/2023



USER NAME = amkluver	DESIGNED - VLJ	REVISED -
PLOT SCALE = 0.16666633 1/ in.	DRAWN - AMK	REVISED -
PLOT DATE = 6/23/2023	CHECKED - JMG	REVISED -
	DATE - 11/11/22	REVISED -

**STATE OF ILLINOIS**  
**DEPARTMENT OF TRANSPORTATION**

**ALIGNMENT, TIES AND BENCHMARKS**  
 SCALE: 1"=100'    SHEET 3 OF 8 SHEETS    STA. 453+00.00 TO STA. 477+00.00

F.A.I. RTE.	SECTION	COUNTY	TOTAL SHEETS	SHEET NO.
I-80	FAI 80 21 STRUCTURE 6	WILL	898	37
CONTRACT NO. 62R27				
ILLINOIS FED. AID PROJECT				

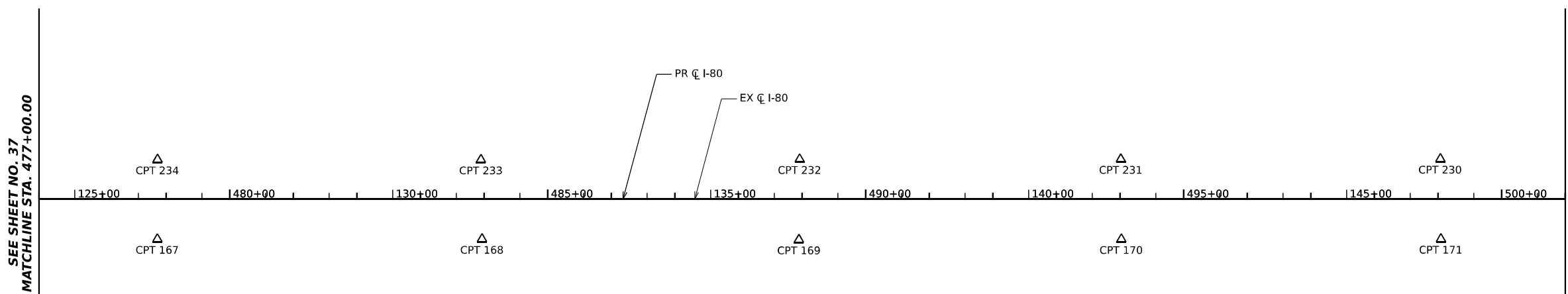
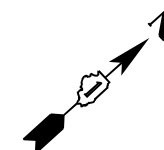

CONTROL POINT INFORMATION

POINT	NORTHING	EASTING	ELEVATION	DESCRIPTION
CPT 167	1759983.604	1032056.784	600.721	MAG NAIL
CPT 168	1760362.328	1032399.165	598.235	MAG NAIL
CPT 169	1760731.324	1032734.133	596.251	MAG NAIL
CPT 170	1761107.649	1033073.582	596.220	MAG NAIL
CPT 171	1761480.611	1033410.240	597.349	MAG NAIL
CPT 230	1761564.470	1033316.208	597.286	MAG NAIL
CPT 231	1761191.672	1032979.593	596.166	MAG NAIL
CPT 232	1760816.907	1032640.931	596.222	MAG NAIL
CPT 233	1760444.848	1032305.450	598.125	MAG NAIL
CPT 234	1760067.564	1031964.059	600.750	MAG NAIL

MODEL: BL\_IP\_00\_W\_ATB\_4 (Sheet)  
 FILE NAME: P:\Projects\2022\2022-23\TransSystems\CAD\62R27\Struct\04-Align & Ties\03\62R27-ATB-Sheets.dgn



USER NAME = amkluver	DESIGNED - VLJ	REVISED -
DRAWN - AMK	REVISIONS -	
PLOT SCALE = 0.16666633 1/16 in.	CHECKED - JMG	REVISED -
PLOT DATE = 6/23/2023	DATE - 11/11/22	REVISED -

**STATE OF ILLINOIS**  
**DEPARTMENT OF TRANSPORTATION**

**ALIGNMENT, TIES AND BENCHMARKS**  
 SCALE: 1"=100'    SHEET 4 OF 8 SHEETS    STA. 477+00.00 TO STA. 501+00.00

F.A.I. RTE.	SECTION	COUNTY	TOTAL SHEETS	SHEET NO.
I-80	FAI 80 21 STRUCTURE 6	WILL	898	38
CONTRACT NO. 62R27				
		ILLINOIS	FED. AID PROJECT	



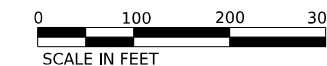
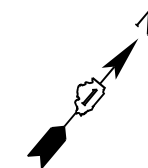

BENCHMARK INFORMATION

BENCHMARK	ELEVATION	NORTHING	EASTING	DESCRIPTION
16	591.589	1756836.1	1028909.5	CUT SQUARE ON EASTERLY SIDE OF CONCRETE FOUNDATION FOR THE OVERHEAD HIGHWAY SIGN "EXIT 126B" EAST OF THE GORE AT I-80 WESTBOUND AND I-80 WESTBOUND ON-RAMP FROM HOUBOLT ROAD, SOUTH OF THE RAMP ON THE NORTH SIDE OF WESTBOUND I-80
17	592.424	1757031.0	1029423.1	CUT CROSS ON TOP OF SOUTHERLY FOUNDATION BOLT OF THE FIRST LIGHT POLE EAST OF THE GORE AT I-80 AND I-80 OFF-RAMP TO HOUBOLT ROAD NORTH OF THE RAMP, ON THE SOUTH SIDE OF EASTBOUND I-80
18	597.850	1757941.5	1030272.8	CUT CROSS ON TOP OF SOUTHERLY FOUNDATION BOLT OF THE FIRST LIGHT POLE WEST OF THE GORE AT I-80 EAST BOUND AND I-80 ON-RAMP FROM HOUBOLT ROAD, NORTH OF THE RAMP, ON THE SOUTH SIDE OF EASTBOUND I-80
19	595.744	1758086.6	1030108.4	CUT CROSS ON TOP OF NORTHERLY FOUNDATION BOLT OF THE FIRST LIGHT POLE WEST OF THE GORE AT I-80 WEST BOUND AND I-80 OFF-RAMP TO HOUBOLT ROAD, SOUTH OF THE RAMP, ON THE NORTH SIDE OF WESTBOUND I-80
20	579.588	1757185.6	1029983.5	SET CUT SQUARE IN THE TOP WESTERLY SIDE OF CONCRETE TRAFFIC SIGNAL FOUNDATION AT THE SOUTHEAST QUADRANT OF HOUBOLT ROAD AND I-80 EAST BOUND ON RAMP
21	588.313	1757817.3	1029480.8	SET CUT SQUARE ON TOP OF CONCRETE FOUNDATION FOR CANTILEVERED TRAFFIC SIGNAL AT THE SOUTHWEST QUADRANT OF HOUBOLT ROAD AND I-80 WEST BOUND ON RAMP
22	593.579	1757796.8	1029195.3	SET 2" CWA ALUMINUM DISC ON THE TOP SOUTHERLY SIDE OF THE CONCRETE FOUNDATION FOR THE FIRST LIGHT POLE WEST OF HOUBOLT ROAD ON THE NORTH SIDE OF I-80 WEST BOUND ON RAMP

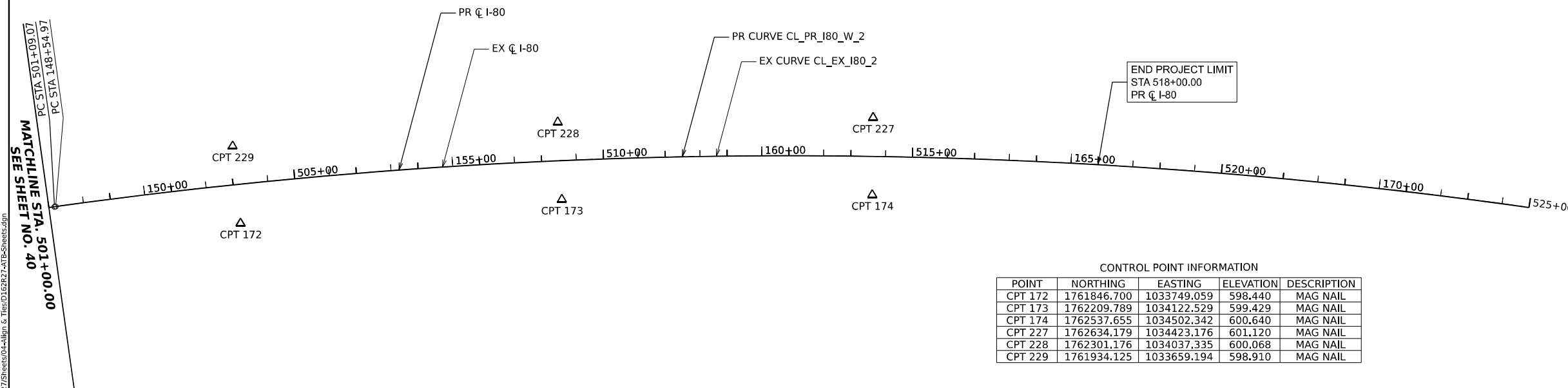

CONTROL POINT INFORMATION

POINT	NORTHING	EASTING	ELEVATION	DESCRIPTION
CPT 172	1761846.700	1033749.059	598.440	MAG NAIL
CPT 173	1762209.789	1034122.529	599.429	MAG NAIL
CPT 174	1762537.655	1034502.342	600.640	MAG NAIL
CPT 227	1762634.179	1034423.176	601.120	MAG NAIL
CPT 228	1762301.176	1034037.335	600.068	MAG NAIL
CPT 229	1761934.125	1033659.194	598.910	MAG NAIL

MODEL: BL\_PR\_I80\_W\_ATB\_5 (Sheet)  
 FILE NAME: P:\Projects\Illinois\Projects\2018\CI-401\401-180022\02-TransSystems\CAD\62R27\Structs\04-Align & Ties\03\62R27-ATB-Sheets.dgn  
 MODEL: BL\_PR\_I80\_W\_ATB\_5 (Sheet)  
 FILE NAME: P:\Projects\Illinois\Projects\2018\CI-401\401-180022\02-TransSystems\CAD\62R27\Structs\04-Align & Ties\03\62R27-ATB-Sheets.dgn

MATCHLINE STA. 501+00.00  
 SEE SHEET NO. 40

**TRANSYSTEMS**

USER NAME = amkluver	DESIGNED - VLJ	REVISED -
PLOT SCALE = 0.16666633 1/ in.	DRAWN - AMK	REVISED -
PLOT DATE = 6/23/2023	CHECKED - JMG	REVISED -
	DATE - 11/11/22	REVISED -

**STATE OF ILLINOIS  
DEPARTMENT OF TRANSPORTATION**

<b>ALIGNMENT, TIES AND BENCHMARKS</b>			
SCALE: 1"=100'	SHEET 5	OF 8 SHEETS	STA. 501+00.00 TO STA. 518+00.00

F.A.I. RTE.	SECTION	COUNTY	TOTAL SHEETS	SHEET NO.
I-80	FAI 80 21 STRUCTURE 6	WILL	898	39
				CONTRACT NO. 62R27
		ILLINOIS	FED. AID PROJECT	

**EXISTING CURVE DATA**

**EXISTING I-80 (CL\_EX\_I80)**

EX CURVE CL_EX_I80_1 PI STA = 69+94.82 Δ = 46°06'50" (LT) D = 01°00'01" R = 5,727.40' T = 2,437.86' L = 4609.64' E = 497.25' PC STA = 45+56.96 PT STA = 91+66.60	EX CURVE CL_EX_I80_2 PI STA = 184+67.47 Δ = 45°35'36" (RT) D = 00°40'00" R = 8,595.18' T = 3,612.50' L = 6839.66' E = 728.30' PC STA = 148+54.97 PT STA = 216+94.63
---	--

**EXISTING HOUBOLT RAMP A (BL\_EX\_HBLT\_A)**

EX CURVE BL_EX_HBLT_A_1 PI STA = 1204+40.25 Δ = 113°58'54" (LT) D = 20°02'01" R = 286.00' T = 440.25' L = 568.96' E = 238.99' PC STA = 1200+00.00 PT STA = 1205+68.96	EX CURVE BL_EX_HBLT_A_2 PI STA = 1212+45.34 Δ = 40°59'05" (RT) D = 06°45'00" R = 848.84' T = 317.24' L = 607.19' E = 57.34' PC STA = 1209+28.10 PT STA = 1215+35.29
--	--

**NOTES:**

- FOR PROPOSED SUPERELEVATION RATES AND TRANSITION LENGTHS, SEE PAVEMENT ELEVATION AND SUPERELEVATION DETAILS ON SHEETS 76 TO 87

**EXISTING HOUBOLT RAMP B (BL\_EX\_HBLT\_B)**

EX CURVE BL\_EX\_HBLT\_B\_1  
PI STA = 203+52.27  
Δ = 20°07'34" (RT)  
D = 06°44'26"  
R = 850.00'  
T = 150.84'  
L = 298.58'  
E = 13.28'  
PC STA = 202+01.42  
PT STA = 205+00.00

**EXISTING HOUBOLT RAMP C (BL\_EX\_HBLT\_C)**

EX CURVE BL_EX_HBLT_C_1 PI STA = 304+06.97 Δ = 45°00'00" (LT) D = 12°11'26" R = 470.00' T = 194.68' L = 369.14' E = 38.72' PC STA = 302+12.28 PT STA = 305+81.42	EX CURVE BL_EX_HBLT_C_2 PI STA = 310+81.85 Δ = 29°47'17" (RT) D = 06°44'26" R = 850.00' T = 226.07' L = 441.92' E = 29.55' PC STA = 308+55.78 PT STA = 312+97.69
---	---

**EXISTING HOUBOLT RAMP D (BL\_EX\_HBLT\_D)**

EX CURVE BL\_EX\_HBLT\_D\_1  
PI STA = 403+02.60  
Δ = 03°21'20" (RT)  
D = 01°22'26"  
R = 4,170.00'  
T = 122.14'  
L = 244.21'  
E = 1.79'  
PC STA = 401+80.46  
PT STA = 404+24.67

**EXISTING HOUBOLT ROAD (BL\_EX\_HBLT)**

EX CURVE BL_EX_HBLT_1 PI STA = 4142+13.34 Δ = 10°31'02" (LT) D = 02°51'53" R = 2,000.00' T = 184.08' L = 367.12' E = 8.45' PC STA = 4140+29.26 PT STA = 4143+96.38	EX CURVE BL_EX_HBLT_2 PI STA = 4168+39.48 Δ = 02°37'38" (LT) D = 00°52'53" R = 6,500.00' T = 149.05' L = 298.05' E = 1.71' PC STA = 4166+90.43 PT STA = 4169+88.48	EX CURVE BL_EX_HBLT_3 PI STA = 4164+46.79 Δ = 02°19'09" (RT) D = 00°52'53" R = 6,500.00' T = 131.58' L = 263.12' E = 1.33' PC STA = 4163+15.21 PT STA = 4165+78.33	EX CURVE BL_EX_HBLT_4 PI STA = 4198+28.43 Δ = 32°15'42" (RT) D = 03°15'00" R = 1,763.00' T = 509.89' L = 992.70' E = 72.25' PC STA = 4193+18.54 PT STA = 4203+11.24
---	---	---	--

**EXISTING NB HOUBOLT ROAD (BL\_PR\_HBLT\_NB)**

EX CURVE BL_PR_HBLT_NB_1 PI STA = 6002+48.53 Δ = 12°00'00" (LT) D = 07°09'43" R = 800.00' T = 84.08' L = 167.55' E = 4.41' PC STA = 6001+64.44 PT STA = 6003+31.99	EX CURVE BL_PR_HBLT_NB_2 PI STA = 6006+29.35 Δ = 16°59'46" (RT) D = 11°27'33" R = 500.00' T = 74.71' L = 148.32' E = 5.55' PC STA = 6005+54.64 PT STA = 6007+02.96	EX CURVE BL_PR_HBLT_NB_3 PI STA = 6007+46.59 Δ = 04°59'46" (LT) D = 05°43'46" R = 1,000.00' T = 43.63' L = 87.20' E = 0.95' PC STA = 6007+02.96 PT STA = 6007+90.16	EX CURVE BL_PR_HBLT_NB_4 PI STA = 6011+43.81 Δ = 28°01'42" (RT) D = 21°13'14" R = 270.00' T = 67.39' L = 132.08' E = 8.28' PC STA = 6010+76.42 PT STA = 6012+08.50	EX CURVE BL_PR_HBLT_NB_5 PI STA = 6014+46.89 Δ = 15°05'32" (LT) D = 11°07'31" R = 515.00' T = 68.22' L = 135.65' E = 4.50' PC STA = 6013+78.67 PT STA = 6015+14.32	EX CURVE BL_PR_HBLT_NB_6 PI STA = 6016+50.53 Δ = 19°19'31" (RT) D = 07°09'43" R = 800.00' T = 136.21' L = 269.83' E = 11.51' PC STA = 6015+14.32 PT STA = 6017+84.15
---	---	--	---	---	---

**EXISTING SB HOUBOLT ROAD (BL\_PR\_HBLT\_SB)**

EX CURVE BL_PR_HBLT_SB_1 PI STA = 5001+04.02 Δ = 11°42'21" (LT) D = 06°21'58" R = 900.00' T = 92.26' L = 183.88' E = 4.72' PC STA = 5000+11.76 PT STA = 5001+95.63	EX CURVE BL_PR_HBLT_SB_2 PI STA = 5002+88.45 Δ = 29°42'21" (RT) D = 16°22'13" R = 350.00' T = 92.82' L = 181.46' E = 12.10' PC STA = 5001+95.63 PT STA = 5003+77.10	EX CURVE BL_PR_HBLT_SB_3 PI STA = 5006+35.90 Δ = 26°10'55" (LT) D = 19°05'55" R = 300.00' T = 69.76' L = 137.09' E = 8.00' PC STA = 5005+66.14 PT STA = 5007+03.22	EX CURVE BL_PR_HBLT_SB_4 PI STA = 5007+74.75 Δ = 08°10'55" (RT) D = 05°43'46" R = 1,000.00' T = 71.52' L = 142.80' E = 2.55' PC STA = 5007+03.22 PT STA = 5008+46.02	EX CURVE BL_PR_HBLT_SB_5 PI STA = 5010+30.62 Δ = 11°28'45" (RT) D = 05°43'46" R = 1,000.00' T = 100.51' L = 200.35' E = 5.04' PC STA = 5009+30.11 PT STA = 5011+30.46	EX CURVE BL_PR_HBLT_SB_6 PI STA = 5011+71.73 Δ = 13°27'03" (LT) D = 16°22'13" R = 350.00' T = 41.27' L = 82.17' E = 2.43' PC STA = 5011+30.46 PT STA = 5012+12.63	EX CURVE BL_PR_HBLT_SB_7 PI STA = 5014+95.07 Δ = 34°14'00" (RT) D = 15°04'40" R = 380.00' T = 117.02' L = 227.04' E = 17.61' PC STA = 5013+78.05 PT STA = 5016+05.09
---	--	---	---	--	--	---

MODEL: ATB-Detail-01  
 FILE NAME: p:\transys\transys\comp\pw\checked\Documents\Projects\_2018\01\40118002\02-TransSystems\CAD\62R27\Struct\04-Align & Ties\03\62R27-ATB-Detail.dgn



USER NAME = amkluver	DESIGNED - VLJ	REVISED -
PLOT SCALE = 0.16666633 1/16"	CHECKED - JMG	REVISED -
PLOT DATE = 6/23/2023	DATE - 11/11/22	REVISED -

**STATE OF ILLINOIS  
DEPARTMENT OF TRANSPORTATION**

<b>ALIGNMENT, TIES AND BENCHMARKS</b>			
SCALE:	SHEET 6	OF 8 SHEETS	STA. TO STA.

F.A.I. RTE.	SECTION	COUNTY	TOTAL SHEETS	SHEET NO.
I-80	FAI 80 21 STRUCTURE 6	WILL	898	40
			CONTRACT NO. 62R27	
		ILLINOIS	FED. AID PROJECT	

## EXISTING ALIGNMENT INFORMATION

EX I-80				
POINT	DESCRIPTION	STATION	NORTHING	EASTING
POT		0+00.00	1,755,433.3950	1,021,060.6330
PC	BL_EX_I80_1	45+56.96	1,755,573.6240	1,025,615.4360
PI	BL_EX_I80_1	69+94.82	1,755,648.6430	1,028,052.1430
PT	BL_EX_I80_1	91+66.60	1,757,456.8310	1,029,687.2650
PC	BL_EX_I80_2	148+54.97	1,761,675.9550	1,033,502.5650
PI	BL_EX_I80_2	184+67.47	1,764,355.3860	1,035,925.5410
PT	BL_EX_I80_2	216+94.63	1,764,499.3500	1,039,535.1720
PC	BL_EX_I80_3	294+28.88	1,764,807.5720	1,047,263.2780
PI	BL_EX_I80_3	297+47.72	1,764,820.2780	1,047,581.8580
PT	BL_EX_I80_3	300+60.70	1,764,935.9620	1,047,878.9640
POT		310+67.18	1,765,301.1490	1,048,816.8550

EX HOUBOLT RAMP A				
POINT	DESCRIPTION	STATION	NORTHING	EASTING
PC	BL_EX_HBLT_A_1	1200+00.00	1,757,693.5000	1,029,544.1770
PI	BL_EX_HBLT_A_1	1204+40.25	1,757,956.7010	1,029,191.2700
PT	BL_EX_HBLT_A_1	1205+68.96	1,757,527.2810	1,029,094.2270
PC	BL_EX_HBLT_A_2	1209+28.10	1,757,176.9740	1,029,015.0630
PI	BL_EX_HBLT_A_2	1212+45.34	1,756,867.5360	1,028,945.1350
PT	BL_EX_HBLT_A_2	1215+35.29	1,756,679.8100	1,028,689.3900

EX HOUBOLT RAMP B				
POINT	DESCRIPTION	STATION	NORTHING	EASTING
POT		200+00.00	1,758,440.2490	1,030,456.1290
PC	BL_EX_HBLT_B_1	202+01.42	1,758,298.2560	1,030,313.2660
PI	BL_EX_HBLT_B_1	203+52.27	1,758,191.9210	1,030,206.2790
PT	BL_EX_HBLT_B_1	205+00.00	1,758,128.8920	1,030,069.2370
POT		211+17.19	1,757,871.0000	1,029,508.5120

EX HOUBOLT RAMP C				
POINT	DESCRIPTION	STATION	NORTHING	EASTING
POT		300+00.00	1,757,199.2100	1,029,917.7540
PC	BL_EX_HBLT_C_1	302+12.29	1,757,317.3390	1,030,094.1360
PI	BL_EX_HBLT_C_1	304+06.97	1,757,425.6720	1,030,255.8900
PT	BL_EX_HBLT_C_1	305+81.42	1,757,616.6520	1,030,293.6650
PC	BL_EX_HBLT_C_2	308+55.78	1,757,885.7940	1,030,346.8990
PI	BL_EX_HBLT_C_2	310+81.85	1,758,107.5710	1,030,390.7650
PT	BL_EX_HBLT_C_2	312+97.69	1,758,278.2520	1,030,539.0130
POT		314+95.64	1,758,427.6960	1,030,668.8160

EX HOUBOLT RAMP D				
POINT	DESCRIPTION	STATION	NORTHING	EASTING
POT		400+00.00	1,756,705.9540	1,029,010.7780
PC	BL_EX_HBLT_D_1	401+80.46	1,756,810.0070	1,029,158.2170
PI	BL_EX_HBLT_D_1	403+02.60	1,756,880.4330	1,029,258.0080
PT	BL_EX_HBLT_D_1	404+24.67	1,756,944.8980	1,029,361.7510
POT		410+28.21	1,757,263.4430	1,029,874.3830

EX HOUBOLT ROAD				
POINT	DESCRIPTION	STATION	NORTHING	EASTING
PC	BL_EX_HBLT_1	4140+29.26	1,753,136.0270	1,032,583.4070
PI	BL_EX_HBLT_1	4142+13.34	1,753,305.2160	1,032,510.8820
PT	BL_EX_HBLT_1	4143+96.38	1,753,458.3250	1,032,408.6920
PC	BL_EX_HBLT_2	4163+15.21	1,755,054.3210	1,031,343.4720
PI	BL_EX_HBLT_2	4164+46.79	1,755,163.7600	1,031,270.4290
PT	BL_EX_HBLT_2	4165+78.33	1,755,276.0650	1,031,201.8740
PC	BL_EX_HBLT_3	4166+90.43	1,755,371.7520	1,031,143.4640
PI	BL_EX_HBLT_3	4168+39.48	1,755,498.9730	1,031,065.8050
PT	BL_EX_HBLT_3	4169+88.48	1,755,622.4990	1,030,982.3960
PC	BL_EX_HBLT_4	4193+18.54	1,757,553.5630	1,029,678.4850
PI	BL_EX_HBLT_4	4198+28.43	1,757,976.1410	1,029,393.1480
PT	BL_EX_HBLT_4	4203+11.24	1,758,485.7900	1,029,377.4280
POT		4216+20.83	1,759,794.7600	1,029,337.0530

EX NB HOUBOLT ROAD				
POINT	DESCRIPTION	STATION	NORTHING	EASTING
POT		6000+00.00	1,756,860.6140	1,030,204.3020
PC	BL_PR_HBLT_NB_1	6001+64.44	1,756,996.8980	1,030,112.2800
PI	BL_PR_HBLT_NB_1	6002+48.53	1,757,066.5830	1,030,065.2260
PT	BL_PR_HBLT_NB_1	6003+31.99	1,757,124.9620	1,030,004.7130
PC	BL_PR_HBLT_NB_2	6005+54.64	1,757,279.5470	1,029,844.4760
PI	BL_PR_HBLT_NB_2	6006+29.35	1,757,331.4180	1,029,790.7090
PCC	BL_PR_HBLT_NB_2/BL_PR_HBLT_NB_3	6007+02.96	1,757,396.7390	1,029,754.4530
PI	BL_PR_HBLT_NB_3	6007+46.59	1,757,434.8850	1,029,733.2810
PT	BL_PR_HBLT_NB_3	6007+90.16	1,757,471.0420	1,029,708.8660
PC	BL_PR_HBLT_NB_4	6010+76.42	1,757,708.2790	1,029,548.6770
PI	BL_PR_HBLT_NB_4	6011+43.81	1,757,764.1290	1,029,510.9650
PT	BL_PR_HBLT_NB_4	6012+08.50	1,757,831.1500	1,029,503.9210
PC	BL_PR_HBLT_NB_5	6013+78.67	1,758,000.3830	1,029,486.1340
PI	BL_PR_HBLT_NB_5	6014+46.89	1,758,068.2320	1,029,479.0030
PCC	BL_PR_HBLT_NB_5/BL_PR_HBLT_NB_6	6015+14.32	1,758,131.8830	1,029,454.4520
PI	BL_PR_HBLT_NB_6	6016+50.53	1,758,258.9680	1,029,405.4340
PT	BL_PR_HBLT_NB_6	6017+84.15	1,758,395.1130	1,029,401.2350
POT		6020+06.07	1,758,616.9260	1,029,394.3930

EX SB HOUBOLT ROAD				
POINT	DESCRIPTION	STATION	NORTHING	EASTING
POT		5000+00.00	1,756,816.9650	1,030,139.6590
PC	BL_PR_HBLT_SB_1	5000+11.76	1,756,826.7090	1,030,133.0800
PI	BL_PR_HBLT_SB_1	5001+04.02	1,756,903.1690	1,030,081.4510
PCC	BL_PR_HBLT_SB_1/BL_PR_HBLT_SB_2	5001+95.63	1,756,967.5650	1,030,015.3840
PI	BL_PR_HBLT_SB_2	5002+88.45	1,757,032.3520	1,029,948.9150
PT	BL_PR_HBLT_SB_2	5003+77.10	1,757,121.5630	1,029,923.2860
PC	BL_PR_HBLT_SB_3	5005+66.14	1,757,303.2540	1,029,871.0890
PI	BL_PR_HBLT_SB_3	5006+35.90	1,757,370.3050	1,029,851.8270
PCC	BL_PR_HBLT_SB_3/BL_PR_HBLT_SB_4	5007+03.22	1,757,421.9760	1,029,804.9570
PI	BL_PR_HBLT_SB_4	5007+74.75	1,757,474.9520	1,029,756.9050
PT	BL_PR_HBLT_SB_4	5008+46.02	1,757,534.2260	1,029,716.8810
PC	BL_PR_HBLT_SB_5	5009+30.11	1,757,603.9120	1,029,669.8270
PI	BL_PR_HBLT_SB_5	5010+30.62	1,757,687.2120	1,029,613.5800
PCC	BL_PR_HBLT_SB_5/BL_PR_HBLT_SB_6	5011+30.46	1,757,780.0400	1,029,575.0360
PI	BL_PR_HBLT_SB_6	5011+71.73	1,757,818.1580	1,029,559.2090
PT	BL_PR_HBLT_SB_6	5012+12.63	1,757,851.5490	1,029,534.9490
PC	BL_PR_HBLT_SB_7	5013+78.05	1,757,985.3760	1,029,437.7180
PI	BL_PR_HBLT_SB_7	5014+95.07	1,758,080.0510	1,029,368.9330
PT	BL_PR_HBLT_SB_7	5016+05.09	1,758,197.0190	1,029,365.3250
POT		5020+23.90	1,758,615.6310	1,029,352.4130

MODEL: I:\Projects\I80\1100022\02-TransSystems\p-w-Tested\Documents\Projects\_2018\C1-401\401180022\02-TransSystems\CAD\222\Brects\04-Align & Test\03162827-ATB-Detail.dwg  
 FILE NAME: I:\Projects\I80\1100022\02-TransSystems\p-w-Tested\Documents\Projects\_2018\C1-401\401180022\02-TransSystems\CAD\222\Brects\04-Align & Test\03162827-ATB-Detail.dwg  
 USER: amkluver



USER NAME	= amkluver	DESIGNED -	V LJ	REVISED -	
PLOT SCALE	= 0.16666633 1/1 in.	DRAWN -	AMK	REVISED -	
PLOT DATE	= 6/23/2023	CHECKED -	JMG	REVISED -	
		DATE -	11/11/22	REVISED -	

**STATE OF ILLINOIS  
 DEPARTMENT OF TRANSPORTATION**

**ALIGNMENT, TIES AND BENCHMARKS**  
 SCALE: SHEET 7 OF 8 SHEETS STA. TO STA.

F.A.I. RTE.	SECTION	COUNTY	TOTAL SHEETS	SHEET NO.
I-80	FAI 80 21 STRUCTURE 6	WILL	898	41
ILLINOIS   FED. AID PROJECT			CONTRACT NO. 62R27	

**PROPOSED CURVE DATA**

**PROPOSED I-80 (CL\_PR\_I80\_W)**

PR CURVE CL_PR_I80_W_1 PI STA = 422+52.00 Δ = 46°06'50" (LT) D = 00°59'47" R = 5,750.00' T = 2,447.48' L = 4627.83' E = 499.21' e = -3.40% TR = 107' SE RUN = 255' PC STA = 398+04.52 PT STA = 444+32.35 DESIGN SPEED = 70MPH	PR CURVE CL_PR_I80_W_2 PI STA = 537+23.60 Δ = 45°35'36" (RT) D = 00°39'58" R = 8,600.00' T = 3,614.53' L = 6843.50 E = 728.71' e = 2.40% TR (PC) = 103' TR (PT) = 129' SE RUN (PC) = 144' SE RUN (PT) = 180' PC STA = 501+09.07 PT STA = 569+52.57 DESIGN SPEED = 70MPH
--	--

**PROPOSED HOUBOLT RAMP A (BL\_PR\_HBLT\_A)**

PR CURVE BL_PR_HBLT_A_1 PI STA = 404+89.39 Δ = 116°38'17" (LT) D = 20°02'01" R = 286.00' T = 463.42' L = 582.21' E = 258.56' e = -4.20% TR = 43' SE RUN = 87' PC STA = 400+25.97 PT STA = 406+08.18 DESIGN SPEED = 20MPH	PR CURVE BL_PR_HBLT_A_2 PI STA = 412+60.92 Δ = 44°37'04" (RT) D = 06°48'17" R = 842.00' T = 345.48' L = 655.69 E = 68.12' e = 6.00% TR (PC) = 0' TR (PT) = 0' SE RUN (PC) = 128' SE RUN (PT) = 78' PC STA = 409+15.44 PT STA = 415+71.13 DESIGN SPEED = 50MPH	PR CURVE BL_PR_HBLT_A_3 PI STA = 417+83.40 Δ = 02°49'40" (RT) D = 00°39'58" R = 8,600.00' T = 212.27' L = 424.45 E = 2.62' e = 3.40% TR = 0' SE RUN = 0' PC STA = 415+71.13 PT STA = 419+95.58 DESIGN SPEED = 70MPH	PR CURVE BL_PR_HBLT_A_4 PI STA = 427+76.83 Δ = 15°38'24" (RT) D = 01°00'26" R = 5,688.50' T = 781.25' L = 1552.79 E = 53.40' e = 3.40% TR = 0' SE RUN = 0' PC STA = 419+95.58 PT STA = 435+48.37 DESIGN SPEED = 70MPH
---	--	--	--

**NOTES:**

- FOR PROPOSED SUPERELEVATION RATES AND TRANSITION LENGTHS, SEE PAVEMENT ELEVATION AND SUPERELEVATION DETAILS ON SHEETS 76 TO 87

**PROPOSED HOUBOLT RAMP B (BL\_PR\_HBLT\_B)**

PR CURVE BL\_HBLT\_B\_1  
PI STA = 307+18.99  
Δ = 19°10'42" (RT)  
D = 06°44'26"  
R = 850.00'  
T = 143.60'  
L = 284.52  
E = 12.05'  
e = 6.00%  
TR = 64'  
SE RUN = 192'  
PC STA = 305+75.39  
PT STA = 308+59.91  
DESIGN SPEED = 50MPH

**PROPOSED HOUBOLT RAMP C (BL\_PR\_HBLT\_C)**

PR CURVE BL_PR_HBLT_C_1 PI STA = 204+12.86 Δ = 45°00'00" (LT) D = 12°11'26" R = 470.00' T = 194.68' L = 369.14' E = 38.72' PC STA = 202+18.17 PT STA = 205+87.31	PR CURVE BL_PR_HBLT_C_2 PI STA = 211+02.13 Δ = 29°47'19" (RT) D = 06°51'42" R = 835.00' T = 222.09' L = 434.12 E = 29.03' e = 6.00% TR (PC) = 0' TR (PT) = 0' SE RUN (PC) = 151' SE RUN (PT) = 128' PC STA = 208+80.04 PT STA = 213+14.16 DESIGN SPEED = 50MPH
---	---

**PROPOSED HOUBOLT RAMP D (BL\_PR\_HBLT\_D)**

PR CURVE BL_PR_HBLT_D_1 PI STA = 99+71.86 Δ = 03°23'57" (LT) D = 00°59'21" R = 5,792.13' T = 171.86' L = 343.63' E = 2.55' e = -3.40% TR (PT) = 73' SE RUN (PT) = 123' PC STA = 98+00.00 PT STA = 101+43.63 DESIGN SPEED = 50MPH	PR CURVE BL_PR_HBLT_D_2 PI STA = 105+64.16 Δ = 00°43'44" (LT) D = 00°24'44" R = 13,898.00' T = 88.40' L = 176.79' E = 0.28' e = 2.00% TR = NORMAL CROWN SE RUN = NORMAL CROWN PC STA = 104+75.76 PT STA = 106+52.55 DESIGN SPEED = 30MPH	PR CURVE BL_PR_HBLT_D_3 PI STA = 107+13.69 Δ = 01°40'48" (RT) D = 01°22'26" R = 4,170.00' T = 61.14' L = 122.27 E = 0.45' PC STA = 106+52.55 PT STA = 107+74.82
---	---	--

**PROPOSED ALIGNMENT INFORMATION**

PR I-80				
POINT	DESCRIPTION	STATION	NORTHING	EASTING
POT		352+57.18	1,755,433.3950	1,021,060.6330
PC	BL PR I80_W 1	398+04.52	1,755,573.3280	1,025,605.8210
PI	BL PR I80_W 1	422+52.00	1,755,648.6430	1,028,052.1430
PT	BL PR I80_W 1	444+32.35	1,757,463.9660	1,029,693.7170
PC	BL PR I80_W 2	501+09.07	1,761,674.4520	1,033,501.2070
PI	BL PR I80_W 2	537+23.60	1,764,355.3860	1,035,925.5410
PT	BL PR I80_W 2	569+52.57	1,764,499.4310	1,039,537.1960
PC	BL PR I80_W 3	644+38.47	1,764,797.7560	1,047,017.1490
PI	BL PR I80_W 3	647+80.53	1,764,811.3870	1,047,358.9430
PT	BL PR I80_W 3	16+79.15	1,764,923.8950	1,047,681.9770
POT		23+29.13	1,765,137.6770	1,048,295.7910

PR HOUBOLT RAMP A				
POINT	DESCRIPTION	STATION	NORTHING	EASTING
PC	BL PR HBLT A 1	400+25.97	1,757,693.5000	1,029,544.1770
PI	BL PR HBLT A 1	404+89.39	1,757,970.5520	1,029,172.6980
PT	BL PR HBLT A 1	406+08.19	1,757,514.2860	1,029,091.6060
PC	BL PR HBLT A 2	409+15.44	1,757,211.7700	1,029,037.8400
PI	BL PR HBLT A 2	412+60.92	1,756,871.6200	1,028,977.3850
PCC	BL PR HBLT A 2/BL PR HBLT A 3	415+71.13	1,756,671.9590	1,028,695.4400
PI	BL PR HBLT A 3	417+83.40	1,756,549.2850	1,028,522.2090
PCC	BL PR HBLT A 3/BL PR HBLT A 4	419+95.58	1,756,435.3060	1,028,343.1370
PI	BL PR HBLT A 4	427+76.83	1,756,035.0660	1,027,672.1970
PT	BL PR HBLT A 4	435+48.37	1,755,830.5250	1,026,918.1970
POT		435+48.38	1,755,830.5220	1,026,918.1860

PR HOUBOLT RAMP B				
POINT	DESCRIPTION	STATION	NORTHING	EASTING
POT		300+00.00	1,758,686.4750	1,030,716.3000
PC	BL PR HBLT B 1	305+75.39	1,758,287.6610	1,030,301.5430
PI	BL PR HBLT B 1	307+18.99	1,758,188.1280	1,030,198.0300
PT	BL PR HBLT B 1	308+59.91	1,758,128.1230	1,030,067.5650
POT		314+75.26	1,757,871.0000	1,029,508.5120

PR HOUBOLT RAMP C				
POINT	DESCRIPTION	STATION	NORTHING	EASTING
POT		200+05.89	1,757,199.2100	1,029,917.7540
PC	BL PR HBLT C 1	202+18.18	1,757,317.3390	1,030,094.1360
PI	BL PR HBLT C 1	204+12.86	1,757,425.6720	1,030,255.8900
PT	BL PR HBLT C 1	205+87.31	1,757,616.6520	1,030,293.6650
PC	BL PR HBLT C 2	208+80.04	1,757,903.8160	1,030,350.4640
PI	BL PR HBLT C 2	211+02.13	1,758,121.6820	1,030,393.5560
PT	BL PR HBLT C 2	213+14.16	1,758,289.3520	1,030,539.1910
POT		219+14.40	1,758,742.5160	1,030,932.7990

PR HOUBOLT RAMP D				
POINT	DESCRIPTION	STATION	NORTHING	EASTING
PC	BL PR HBLT D 1	98+00.00	1,756,424.6550	1,028,537.5570
PI	BL PR HBLT D 1	99+71.86	1,756,509.0460	1,028,687.2750
PT	BL PR HBLT D 1	101+43.63	1,756,602.1650	1,028,831.7250
PC	BL PR HBLT D 2	104+75.76	1,756,782.1200	1,029,110.8810
PI	BL PR HBLT D 2	105+64.16	1,756,830.0160	1,029,185.1780
PCC	BL PR HBLT D 2/BL PR HBLT D 3	106+52.55	1,756,878.8530	1,029,258.8610
PI	BL PR HBLT D 3	107+13.69	1,756,912.6300	1,029,309.8220
PT	BL PR HBLT D 3	107+74.82	1,756,944.8980	1,029,361.7510
POT		113+78.36	1,757,263.4430	1,029,874.3830

MODEL: ATB-Detail-03  
 FILE NAME: \\p:\transys\transys\comp\pw\_1\checked\Documents\Projects\_2018\CI-401\401180022\02-Trans\Systems\CAD\022827\Figures\04-Align & Ties\0363822-ATB-Detail-03.dwg



USER NAME = amkluver	DESIGNED - VLJ	REVISED -
PLOT SCALE = 0.16666633 1/16"	CHECKED - JMG	REVISED -
PLOT DATE = 6/23/2023	DATE - 11/11/22	REVISED -

**STATE OF ILLINOIS  
DEPARTMENT OF TRANSPORTATION**

**ALIGNMENT, TIES AND BENCHMARKS**

SCALE: SHEET 8 OF 8 SHEETS STA. TO STA.

F.A.I. RTE.	SECTION	COUNTY	TOTAL SHEETS	SHEET NO.
I-80	FAI 80 21 STRUCTURE 6	WILL	898	42
ILLINOIS FED. AID PROJECT			CONTRACT NO. 62R27	

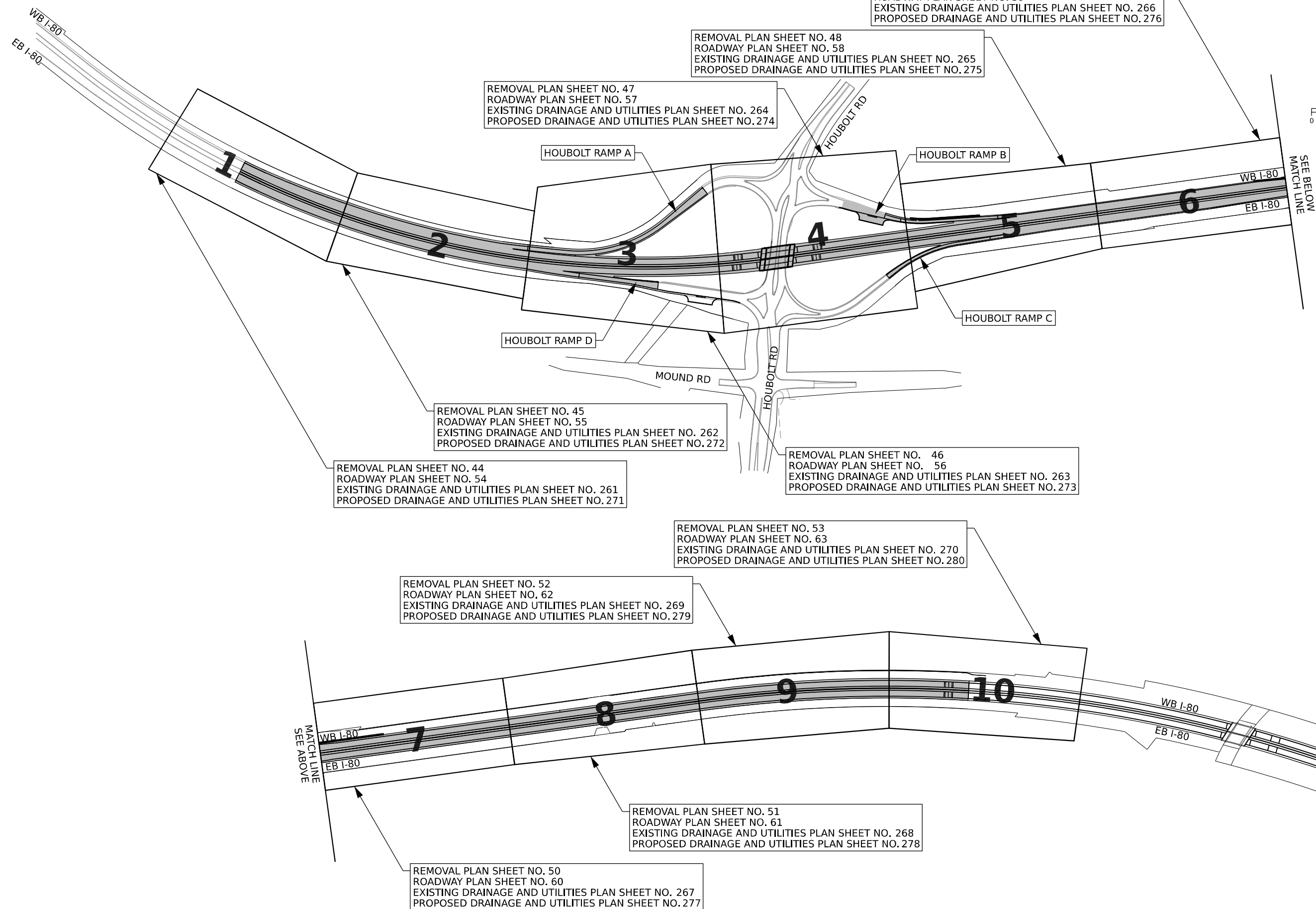
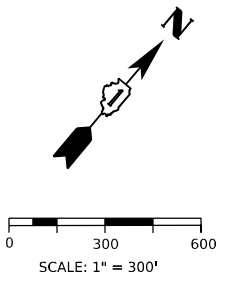

REMOVAL PLAN SHEET NO. 47  
ROADWAY PLAN SHEET NO. 57  
EXISTING DRAINAGE AND UTILITIES PLAN SHEET NO. 264  
PROPOSED DRAINAGE AND UTILITIES PLAN SHEET NO. 274

REMOVAL PLAN SHEET NO. 48  
ROADWAY PLAN SHEET NO. 58  
EXISTING DRAINAGE AND UTILITIES PLAN SHEET NO. 265  
PROPOSED DRAINAGE AND UTILITIES PLAN SHEET NO. 275

REMOVAL PLAN SHEET NO. 49  
ROADWAY PLAN SHEET NO. 59  
EXISTING DRAINAGE AND UTILITIES PLAN SHEET NO. 266  
PROPOSED DRAINAGE AND UTILITIES PLAN SHEET NO. 276

REMOVAL PLAN SHEET NO. 45  
ROADWAY PLAN SHEET NO. 55  
EXISTING DRAINAGE AND UTILITIES PLAN SHEET NO. 262  
PROPOSED DRAINAGE AND UTILITIES PLAN SHEET NO. 272

REMOVAL PLAN SHEET NO. 44  
ROADWAY PLAN SHEET NO. 54  
EXISTING DRAINAGE AND UTILITIES PLAN SHEET NO. 261  
PROPOSED DRAINAGE AND UTILITIES PLAN SHEET NO. 271

REMOVAL PLAN SHEET NO. 46  
ROADWAY PLAN SHEET NO. 56  
EXISTING DRAINAGE AND UTILITIES PLAN SHEET NO. 263  
PROPOSED DRAINAGE AND UTILITIES PLAN SHEET NO. 273

REMOVAL PLAN SHEET NO. 53  
ROADWAY PLAN SHEET NO. 63  
EXISTING DRAINAGE AND UTILITIES PLAN SHEET NO. 270  
PROPOSED DRAINAGE AND UTILITIES PLAN SHEET NO. 280

REMOVAL PLAN SHEET NO. 52  
ROADWAY PLAN SHEET NO. 62  
EXISTING DRAINAGE AND UTILITIES PLAN SHEET NO. 269  
PROPOSED DRAINAGE AND UTILITIES PLAN SHEET NO. 279

REMOVAL PLAN SHEET NO. 51  
ROADWAY PLAN SHEET NO. 61  
EXISTING DRAINAGE AND UTILITIES PLAN SHEET NO. 268  
PROPOSED DRAINAGE AND UTILITIES PLAN SHEET NO. 278

REMOVAL PLAN SHEET NO. 50  
ROADWAY PLAN SHEET NO. 60  
EXISTING DRAINAGE AND UTILITIES PLAN SHEET NO. 267  
PROPOSED DRAINAGE AND UTILITIES PLAN SHEET NO. 277

MODEL: KEY-01  
FILE NAME: p:\transystems\ppl\beetby.com\transystems\ppl\beetby.com\transystems\CAD\62R27\Structs\04-Align & Ties\03162R27-KeyPlan.dgn



USER NAME = amkluver	DESIGNED - VLJ	REVISED -
PLOT SCALE = 99.99980000' / in.	DRAWN - AMK	REVISED -
PLOT DATE = 6/23/2023	CHECKED - JMG	REVISED -
	DATE - 6/26/23	REVISED -

**STATE OF ILLINOIS  
DEPARTMENT OF TRANSPORTATION**

**ROADWAY KEY PLAN**

SCALE: 1"=300'    SHEET 1    OF 1    SHEETS    STA.    TO STA.

F.A.I. RTE.	SECTION	COUNTY	TOTAL SHEETS	SHEET NO.
I-80	FAI 80 21 STRUCTURE 6	WILL	898	43
			CONTRACT NO. 62R27	
ILLINOIS   FED. AID PROJECT				

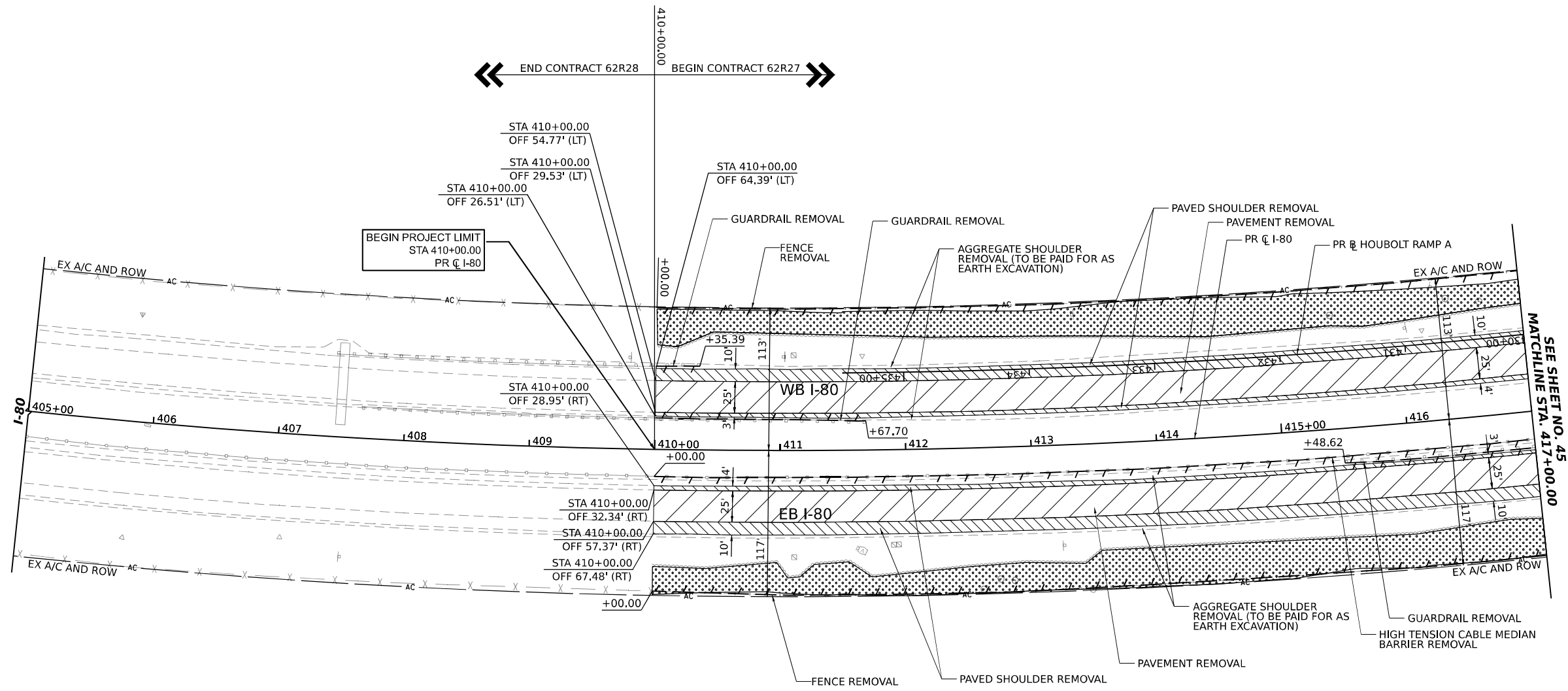
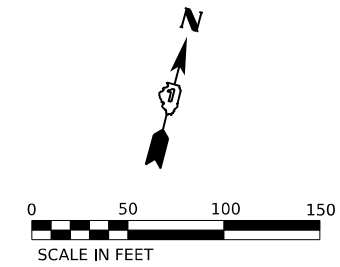

**LEGEND**

- PAVEMENT REMOVAL
- APPROACH SLAB REMOVAL
- PAVED SHOULDER REMOVAL
- TREE REMOVAL, ACRES
- TREE REMOVAL, ACRES (SPECIAL)  
WEED CONTROL, NATIVE  
LANDSCAPE ENHANCEMENT
- LINEAR REMOVAL
- TREE REMOVAL
- TREE TRUNK PROTECTION,  
TREE ROOT PRUNING &  
TREE PRUNING.

**NOTES:**

1. SEE ALIGNMENT AND TIES SHEETS FOR CURVE DATA.
2. ALL STATION AND OFFSETS ARE MEASURED FROM PR C I-80 UNLESS OTHERWISE NOTED.
3. SEE EROSION CONTROL PLANS FOR TEMPORARY FENCE BETWEEN TREE REMOVAL, ACRES AND TREE REMOVAL, ACRES (SPECIAL).

**KEY PLAN**

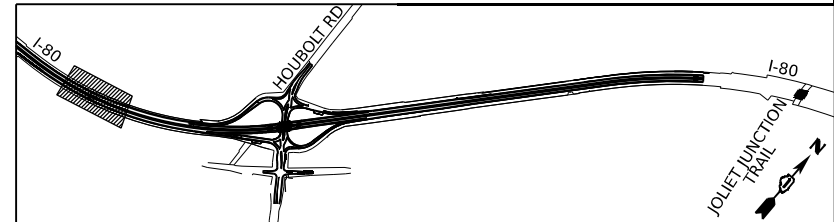

MODEL: BL\_I80\_Plan\_1 (Sheet)  
 FILE NAME: P:\TransSystems\Projects\2018\CH401\401180022\02-TransSystems\CAD\62R27\Structs\05-Road Rem\0162R27\_Removal Sheets



USER NAME = amkluver	DESIGNED - VLJ	REVISED -
PLOT SCALE = 0.16666633 1/ in.	DRAWN - AMK	REVISED -
PLOT DATE = 6/23/2023	CHECKED - JMG	REVISED -
	DATE - 6/26/23	REVISED -

**STATE OF ILLINOIS  
DEPARTMENT OF TRANSPORTATION**

**REMOVAL PLAN**

SCALE: 1"=50'    SHEET 1    OF 10    SHEETS    STA. 411+50.00    TO STA. 417+00.00

F.A.I. RTE.	SECTION	COUNTY	TOTAL SHEETS	SHEET NO.
I-80	FAI 80 21 STRUCTURE 6	WILL	898	44
CONTRACT NO. 62R27				
ILLINOIS   FED. AID PROJECT				

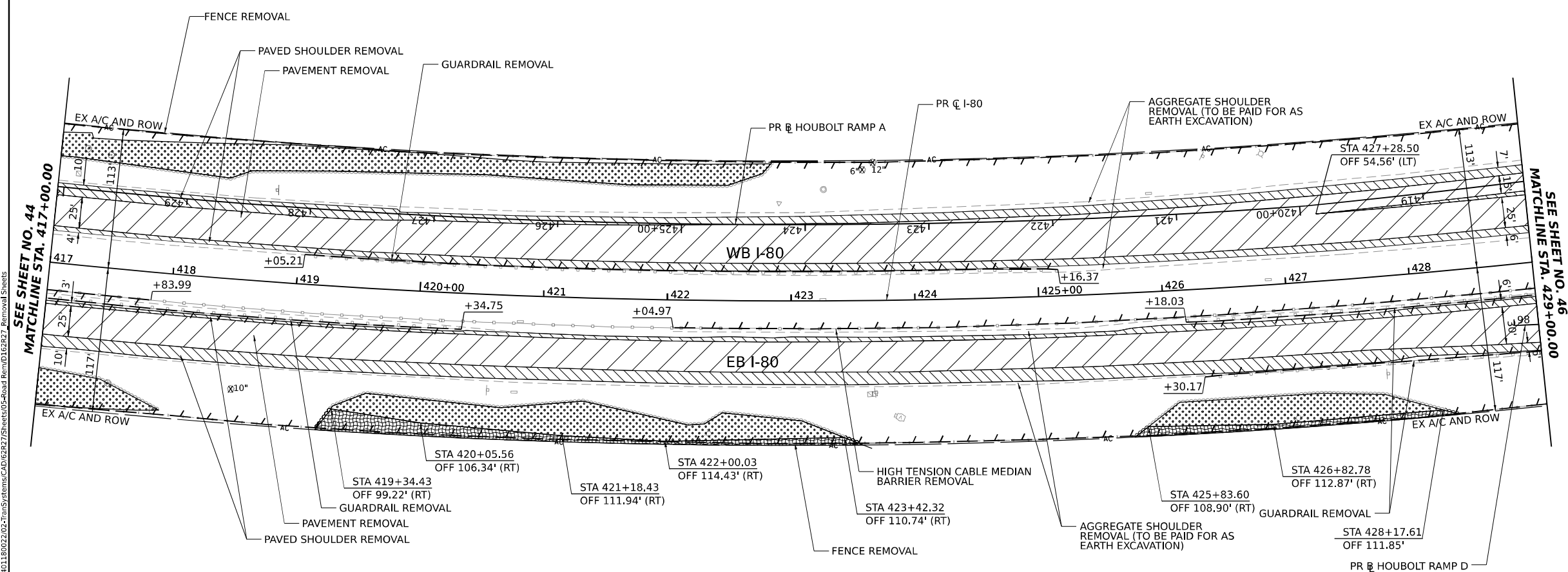
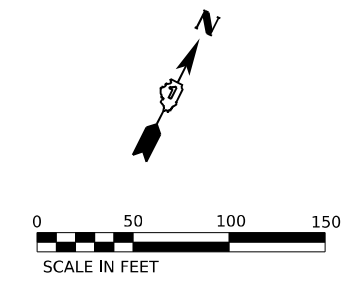

**LEGEND**

- PAVEMENT REMOVAL
- APPROACH SLAB REMOVAL
- PAVED SHOULDER REMOVAL
- TREE REMOVAL, ACRES
- TREE REMOVAL, ACRES (SPECIAL)  
WEED CONTROL, NATIVE  
LANDSCAPE ENHANCEMENT
- LINEAR REMOVAL
- TREE REMOVAL
- TREE TRUNK PROTECTION,  
TREE ROOT PRUNING &  
TREE PRUNING.

**NOTES:**

1. SEE ALIGNMENT AND TIES SHEETS FOR CURVE DATA.
2. ALL STATION AND OFFSETS ARE MEASURED FROM PR C I-80 UNLESS OTHERWISE NOTED.
3. SEE EROSION CONTROL PLANS FOR TEMPORARY FENCE BETWEEN TREE REMOVAL, ACRES AND TREE REMOVAL, ACRES (SPECIAL).

**KEY PLAN**

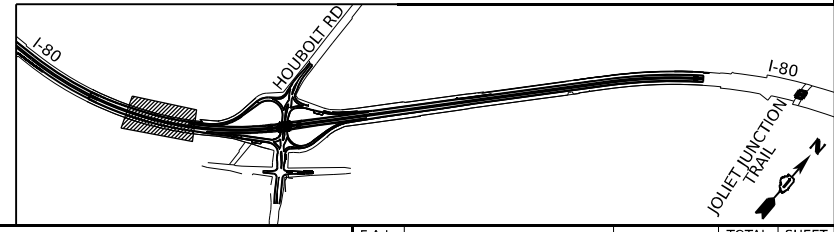

MODEL: BL\_I80\_Plan\_2 (Sheet)  
 FILE NAME: P:\Projects\Illinois\Transportation\I80-Removal\Documents\Projects\_2018\CH401\401180022\02-Traffic\Systems\CAD\62R27\Structs\05-Road Rem\0162R27\_Removal\_Sheets



USER NAME = amkluver	DESIGNED - VLJ	REVISED -
PLOT SCALE = 0.16666633 1/ in.	DRAWN - AMK	REVISED -
PLOT DATE = 6/23/2023	CHECKED - JMG	REVISED -
	DATE - 6/26/23	REVISED -

**STATE OF ILLINOIS  
DEPARTMENT OF TRANSPORTATION**

<b>REMOVAL PLAN</b>		
SCALE: 1"=50'	SHEET 2 OF 10 SHEETS	STA. 417+00.00 TO STA. 429+00.00

F.A.I. RTE.	SECTION	COUNTY	TOTAL SHEETS	SHEET NO.
I-80	FAI 80 21 STRUCTURE 6	WILL	898	45
			CONTRACT NO. 62R27	
ILLINOIS		FED. AID PROJECT		

MODEL: BL\_P0\_00 - Plan 3 (Sheet)  
 FILE NAME: P:\Drawings\Illinois\Projects\2018\01\401180022\02-TransSystemsCAD\62R27\Sheets\05-Road Rem\0162R27\_Removal\_Sheets

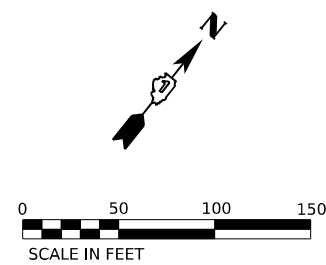
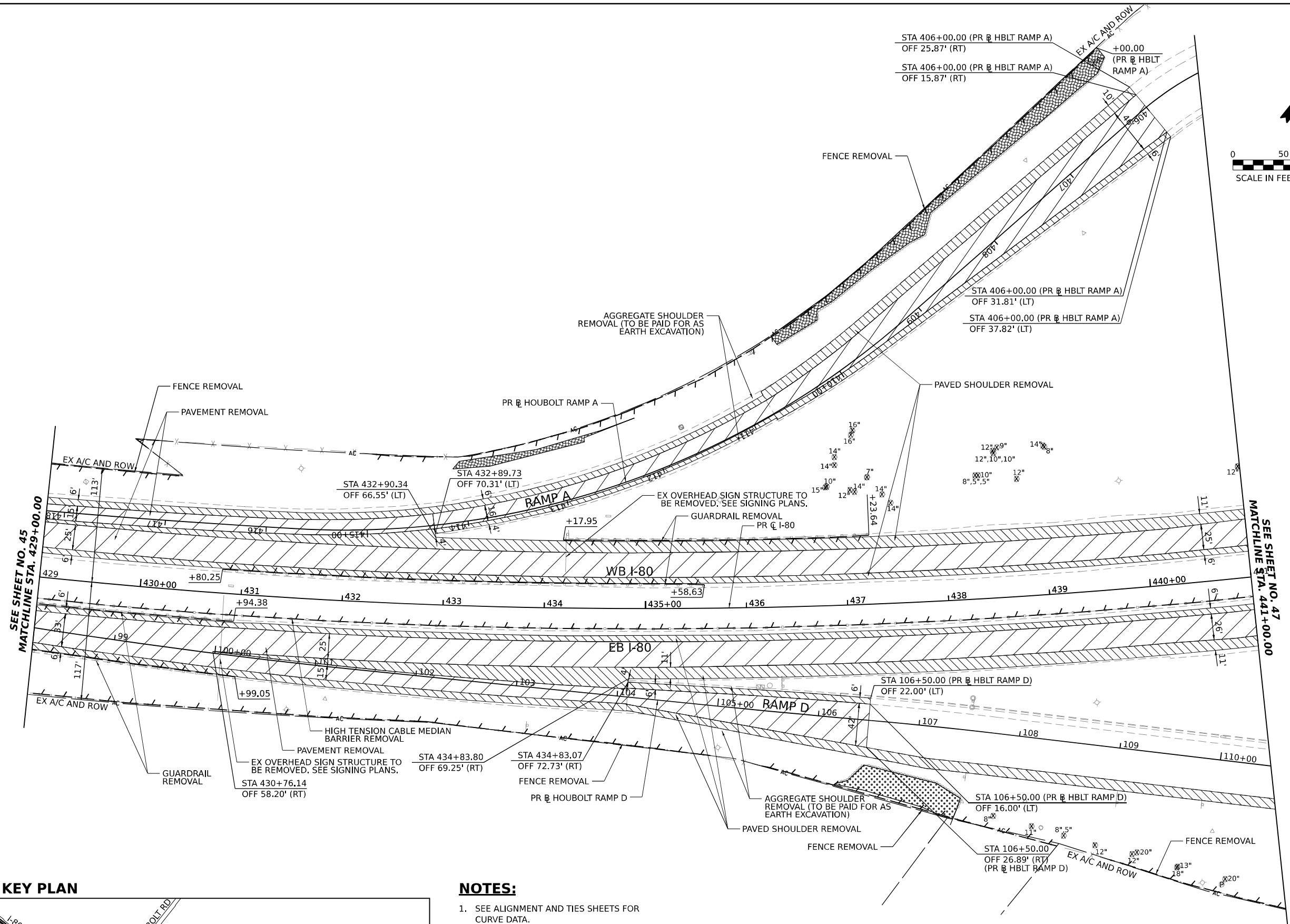

SEE SHEET NO. 45  
 MATCHLINE STA. 429+00.00

SEE SHEET NO. 47  
 MATCHLINE STA. 441+00.00

**LEGEND**

- PAVEMENT REMOVAL
- APPROACH SLAB REMOVAL
- PAVED SHOULDER REMOVAL
- TREE REMOVAL, ACRES
- TREE REMOVAL, ACRES (SPECIAL) WEED CONTROL, NATIVE LANDSCAPE ENHANCEMENT
- LINEAR REMOVAL
- TREE REMOVAL
- TREE TRUNK PROTECTION, TREE ROOT PRUNING & TREE PRUNING.

**KEY PLAN**

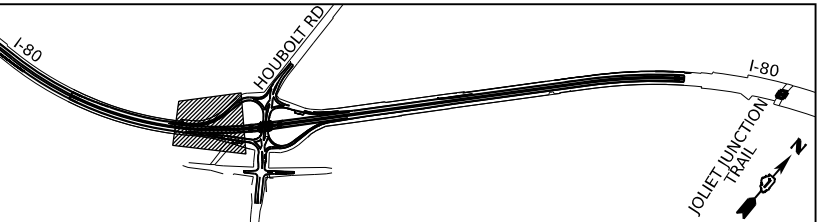

**NOTES:**

1. SEE ALIGNMENT AND TIES SHEETS FOR CURVE DATA.
2. ALL STATION AND OFFSETS ARE MEASURED FROM PR @ I-80 UNLESS OTHERWISE NOTED.
3. SEE EROSION CONTROL PLANS FOR TEMPORARY FENCE BETWEEN TREE REMOVAL, ACRES AND TREE REMOVAL, ACRES (SPECIAL).



USER NAME = amkluver	DESIGNED - VLJ	REVISED -
PLOT SCALE = 0.16666633 1/16"	DRAWN - AMK	REVISED -
PLOT DATE = 6/23/2023	CHECKED - JMG	REVISED -
	DATE - 6/26/23	REVISED -

**STATE OF ILLINOIS  
DEPARTMENT OF TRANSPORTATION**

<b>REMOVAL PLAN</b>			
SCALE: 1"=50'	SHEET 3	OF 10 SHEETS	STA. 429+00.00 TO STA. 441+00.00

F.A.I. RTE.	SECTION	COUNTY	TOTAL SHEETS	SHEET NO.
I-80	FAI 80 21 STRUCTURE 6	WILL	898	46
CONTRACT NO. 62R27				
ILLINOIS FED. AID PROJECT				



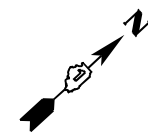



**NOTES:**

1. SEE ALIGNMENT AND TIES SHEETS FOR CURVE DATA.
2. ALL STATION AND OFFSETS ARE MEASURED FROM PR CL I-80 UNLESS OTHERWISE NOTED.
3. EXISTING LUG SYSTEMS TO BE REMOVED. APPROXIMATE LOCATIONS ARE SHOWN FOR INFORMATION ONLY. ACTUAL LOCATIONS OF REMOVAL SHALL BE VERIFIED IN THE FIELD.
4. SEE EROSION CONTROL PLANS FOR TEMPORARY FENCE BETWEEN TREE REMOVAL, ACRES AND TREE REMOVAL, ACRES (SPECIAL).

**LEGEND**

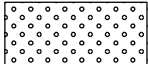
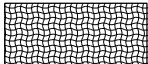
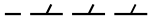
-  PAVEMENT REMOVAL
-  APPROACH SLAB REMOVAL
-  PAVED SHOULDER REMOVAL
-  TREE REMOVAL, ACRES
-  TREE REMOVAL, ACRES (SPECIAL)  
WEED CONTROL, NATIVE  
LANDSCAPE ENHANCEMENT
-  LINEAR REMOVAL
- TREE REMOVAL
- TREE TRUNK PROTECTION,  
TREE ROOT PRUNING &  
TREE PRUNING.

**KEY PLAN**

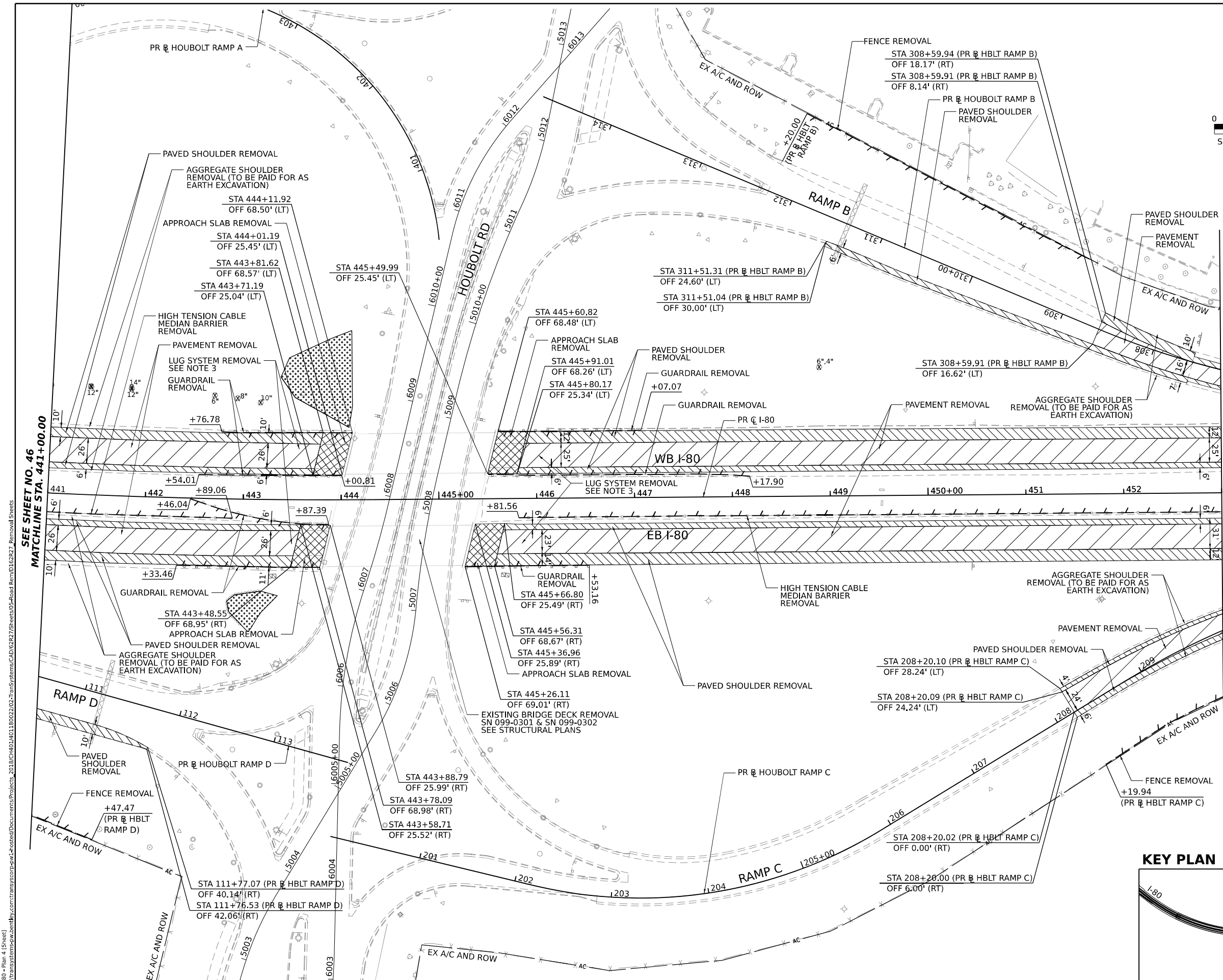
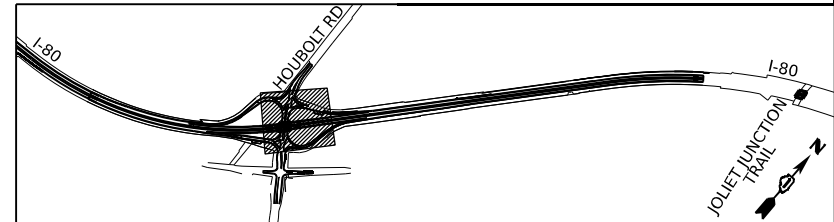

SEE SHEET NO. 46  
MATCHLINE STA. 441+00.00

SEE SHEET NO. 48  
MATCHLINE STA. 453+00.00

MODEL: BL\_PR\_00 - Plan - 4 (Sheet)  
 FILE NAME: P:\Projects\2022\2022-02-TransSystems\2022-02-TransSystems\CAD\2022\2022-02-TransSystems\05-Road Removal\05-Road Removal Sheets



USER NAME = amkluver	DESIGNED - VLJ	REVISED -
PLOT SCALE = 0.16666633 1/ in.	DRAWN - AMK	REVISED -
PLOT DATE = 6/23/2023	CHECKED - JMG	REVISED -
	DATE - 6/26/23	REVISED -

**STATE OF ILLINOIS  
DEPARTMENT OF TRANSPORTATION**

**REMOVAL PLAN**  
SCALE: 1"=50' SHEET 4 OF 10 SHEETS STA. 441+00.00 TO STA. 453+00.00

F.A.I. RTE.	SECTION	COUNTY	TOTAL SHEETS	SHEET NO.
I-80	FAI 80 21 STRUCTURE 6	WILL	898	47
CONTRACT NO. 62R27			ILLINOIS FED. AID PROJECT	

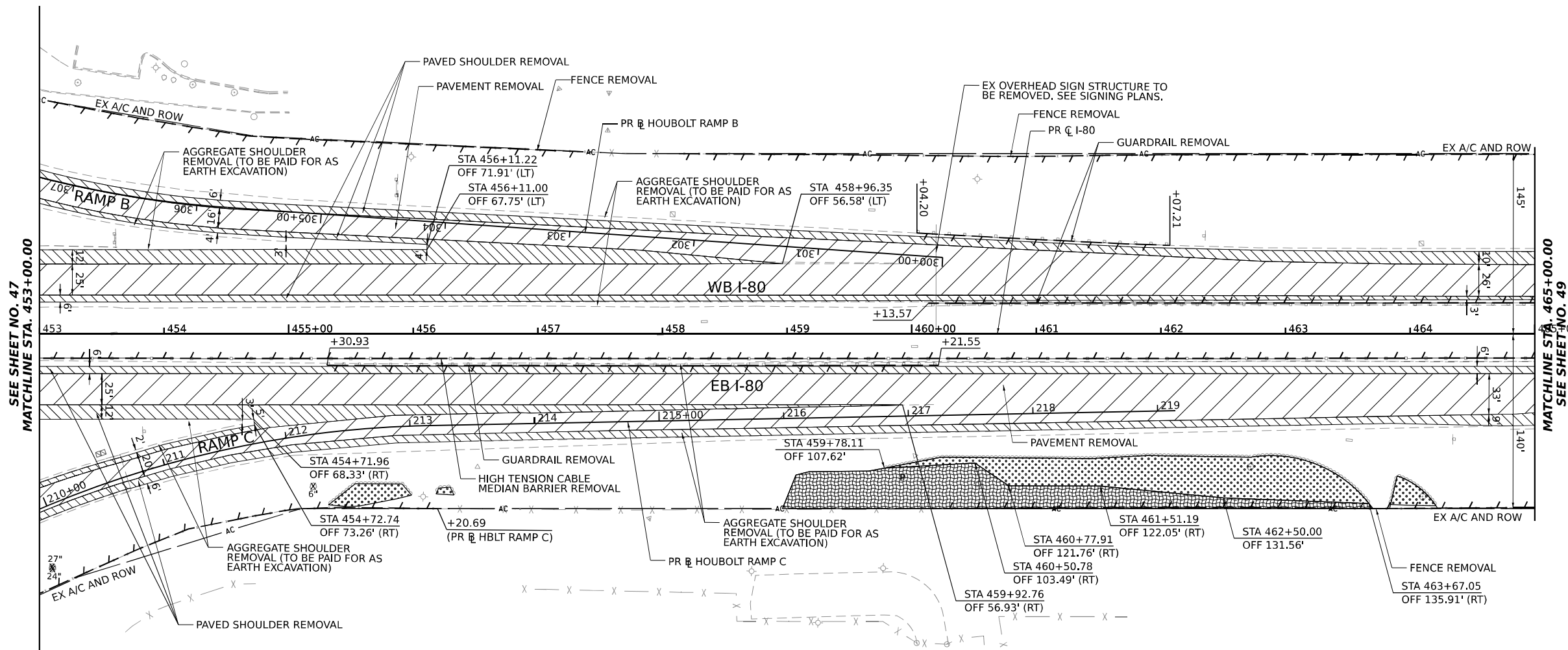
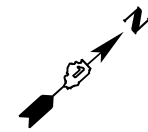

SEE SHEET NO. 47  
MATCHLINE STA. 453+00.00

MATCHLINE STA. 465+00.00  
SEE SHEET NO. 49

**LEGEND**

- PAVEMENT REMOVAL
- APPROACH SLAB REMOVAL
- PAVED SHOULDER REMOVAL
- TREE REMOVAL, ACRES
- TREE REMOVAL, ACRES (SPECIAL)  
WEED CONTROL, NATIVE  
LANDSCAPE ENHANCEMENT
- LINEAR REMOVAL
- TREE REMOVAL
- TREE TRUNK PROTECTION,  
TREE ROOT PRUNING &  
TREE PRUNING.

**NOTES:**

1. SEE ALIGNMENT AND TIES SHEETS FOR CURVE DATA.
2. ALL STATION AND OFFSETS ARE MEASURED FROM PR C I-80 UNLESS OTHERWISE NOTED.
3. SEE EROSION CONTROL PLANS FOR TEMPORARY FENCE BETWEEN TREE REMOVAL, ACRES AND TREE REMOVAL, ACRES (SPECIAL).

**KEY PLAN**

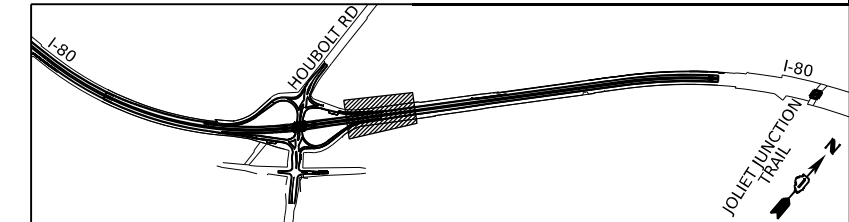

MODEL: BL\_PR\_00\_Plan\_3 (Sheet)  
 FILE NAME: P:\Projects\trans\trans\comp\pwr\hatched\Documents\Projects\_2018\CH401\401180022\02-Trans\Systems\CAD\62R27\Structs\05-Road Rem\0162R27 Removal Sheets



USER NAME = amkluver	DESIGNED - VLJ	REVISED -
PLOT SCALE = 0.16666633 1/ in.	DRAWN - AMK	REVISED -
PLOT DATE = 6/23/2023	CHECKED - JMG	REVISED -
	DATE - 6/26/23	REVISED -

**STATE OF ILLINOIS  
DEPARTMENT OF TRANSPORTATION**

**REMOVAL PLAN**

SCALE: 1"=50'      SHEET 5 OF 10 SHEETS      STA. 453+00.00 TO STA. 465+00.00

F.A.I. RTE.	SECTION	COUNTY	TOTAL SHEETS	SHEET NO.
I-80	FAI 80 21 STRUCTURE 6	WILL	898	48
			CONTRACT NO. 62R27	
ILLINOIS		FED. AID PROJECT		

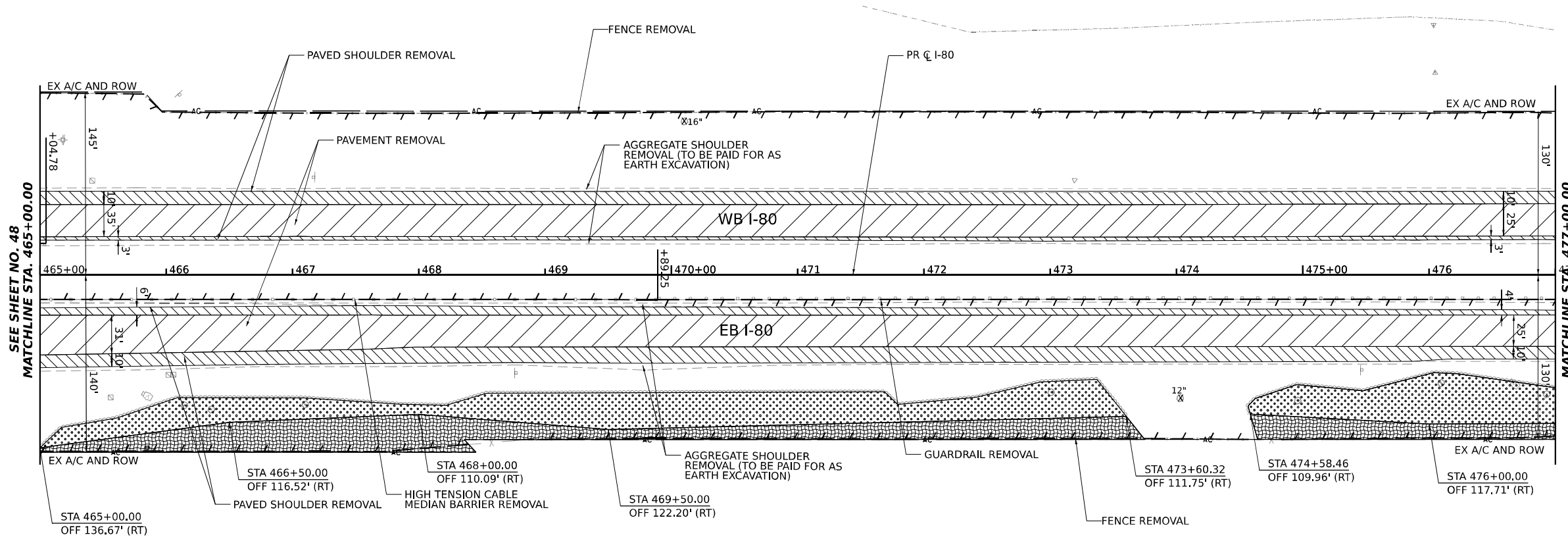
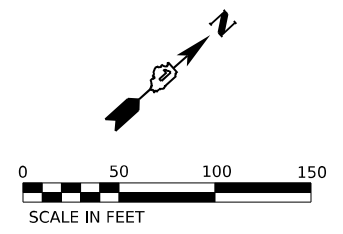

**LEGEND**

- PAVEMENT REMOVAL
- APPROACH SLAB REMOVAL
- PAVED SHOULDER REMOVAL
- TREE REMOVAL, ACRES
- TREE REMOVAL, ACRES (SPECIAL)  
WEED CONTROL, NATIVE LANDSCAPE ENHANCEMENT
- LINEAR REMOVAL
- TREE REMOVAL
- TREE TRUNK PROTECTION,  
TREE ROOT PRUNING &  
TREE PRUNING.

**NOTES:**

1. SEE ALIGNMENT AND TIES SHEETS FOR CURVE DATA.
2. ALL STATION AND OFFSETS ARE MEASURED FROM PR  $\phi$  I-80 UNLESS OTHERWISE NOTED.
3. SEE EROSION CONTROL PLANS FOR TEMPORARY FENCE BETWEEN TREE REMOVAL, ACRES AND TREE REMOVAL, ACRES (SPECIAL).

**KEY PLAN**

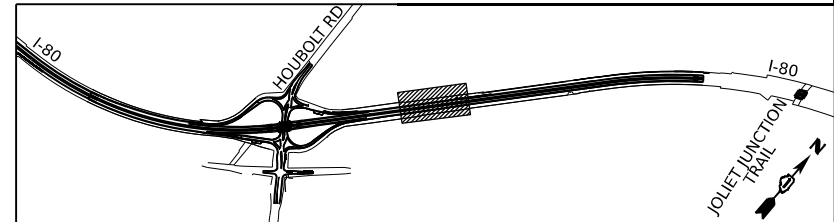

MODEL: BL\_IP\_00 - Plan 6 (Sheet)  
 FILE NAME: P:\Projects\Illinois\Transportation\Systems\CAD\62R27\Structs\05-Road Removal\62R27 Removal Sheets



USER NAME = amkluver	DESIGNED - VLJ	REVISED -
PLOT SCALE = 0.16666633 1/ in.	DRAWN - AMK	REVISED -
PLOT DATE = 6/23/2023	CHECKED - JMG	REVISED -
	DATE - 6/26/23	REVISED -

**STATE OF ILLINOIS  
DEPARTMENT OF TRANSPORTATION**

**REMOVAL PLAN**

SCALE: 1"=50'    SHEET 6 OF 10 SHEETS    STA. 465+00.00 TO STA. 477+00.00

F.A.I. RTE.	SECTION	COUNTY	TOTAL SHEETS	SHEET NO.
I-80	FAI 80 21 STRUCTURE 6	WILL	898	49
CONTRACT NO. 62R27				
ILLINOIS   FED. AID PROJECT				

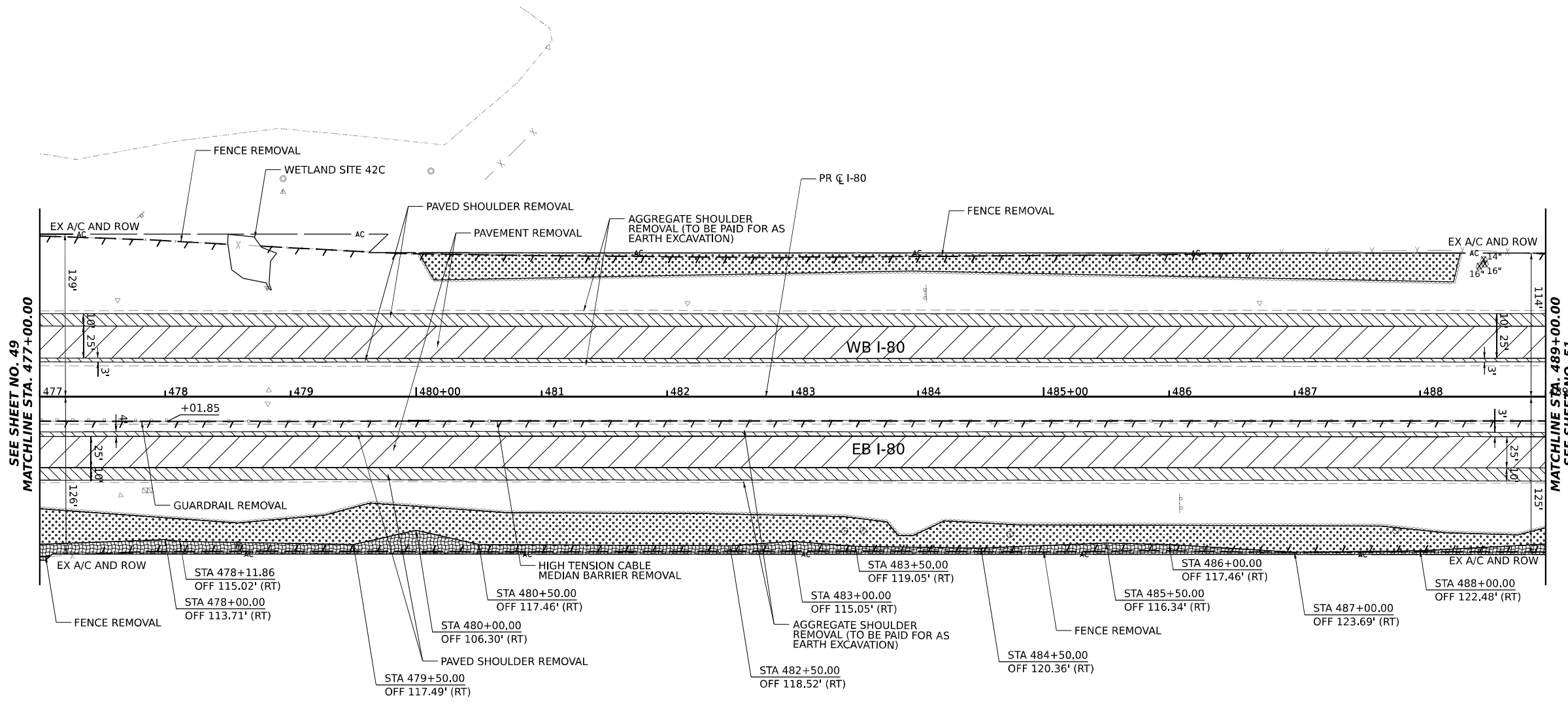
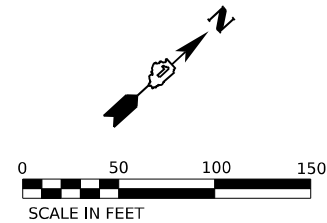

SEE SHEET NO. 49  
MATCHLINE STA. 477+00.00

MATCHLINE STA. 489+00.00  
SEE SHEET NO. 51

**LEGEND**

- PAVEMENT REMOVAL
- APPROACH SLAB REMOVAL
- PAVED SHOULDER REMOVAL
- TREE REMOVAL, ACRES
- TREE REMOVAL, ACRES (SPECIAL)  
WEED CONTROL, NATIVE  
LANDSCAPE ENHANCEMENT
- LINEAR REMOVAL
- TREE REMOVAL
- TREE TRUNK PROTECTION,  
TREE ROOT PRUNING &  
TREE PRUNING.

**NOTES:**

1. SEE ALIGNMENT AND TIES SHEETS FOR CURVE DATA.
2. ALL STATION AND OFFSETS ARE MEASURED FROM PR C I-80 UNLESS OTHERWISE NOTED.
3. SEE EROSION CONTROL PLANS FOR TEMPORARY FENCE BETWEEN TREE REMOVAL, ACRES AND TREE REMOVAL, ACRES (SPECIAL).

**KEY PLAN**

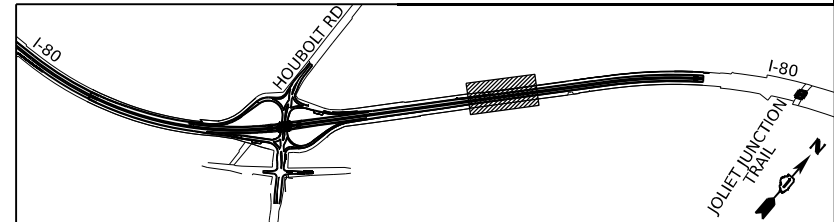

MODEL: BL\_I80\_Plan\_7 (Sheet)  
 FILE NAME: P:\TransSystems\app\client\trans\trans\comp\pw-headers\Documents\Projects\_2018\CH401\401180022\02-TransSystems\CAD\62R27\Structs\05-Road Rem\0162R27\_Removal Sheets



USER NAME = amkluver	DESIGNED - VLJ	REVISED -
PLOT SCALE = 0.16666633 1/ in.	DRAWN - AMK	REVISED -
PLOT DATE = 6/23/2023	CHECKED - JMG	REVISED -
	DATE - 6/26/23	REVISED -

**STATE OF ILLINOIS  
DEPARTMENT OF TRANSPORTATION**

**REMOVAL PLAN**

SCALE: 1"=50'      SHEET 7 OF 10 SHEETS      STA. 477+00.00 TO STA. 489+00.00



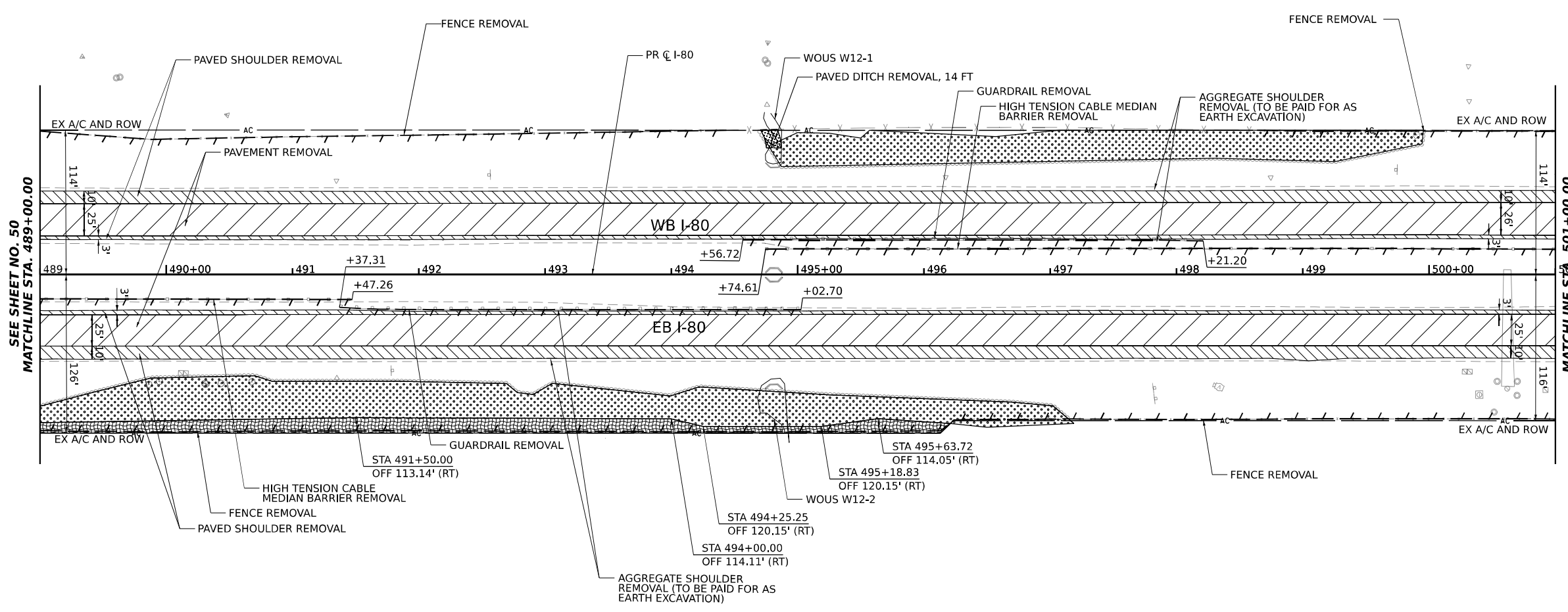
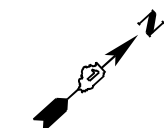



F.A.I. RTE.	SECTION	COUNTY	TOTAL SHEETS	SHEET NO.
I-80	FAI 80 21 STRUCTURE 6	WILL	898	50
CONTRACT NO. 62R27			ILLINOIS   FED. AID PROJECT	

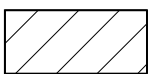

SEE SHEET NO. 50  
MATCHLINE STA. 489+00.00

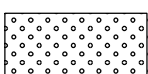
MATCHLINE STA. 501+00.00  
SEE SHEET NO. 52

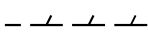
**LEGEND**

-  PAVEMENT REMOVAL
-  APPROACH SLAB REMOVAL
-  PAVED SHOULDER REMOVAL
-  TREE REMOVAL, ACRES
-  TREE REMOVAL, ACRES (SPECIAL)  
WEED CONTROL, NATIVE  
LANDSCAPE ENHANCEMENT
-  LINEAR REMOVAL
-  TREE REMOVAL
-  TREE TRUNK PROTECTION,  
TREE ROOT PRUNING &  
TREE PRUNING.

**NOTES:**

1. SEE ALIGNMENT AND TIES SHEETS FOR CURVE DATA.
2. ALL STATION AND OFFSETS ARE MEASURED FROM PR C I-80 UNLESS OTHERWISE NOTED.
3. SEE EROSION CONTROL PLANS FOR TEMPORARY FENCE BETWEEN TREE REMOVAL, ACRES AND TREE REMOVAL, ACRES (SPECIAL).

**KEY PLAN**

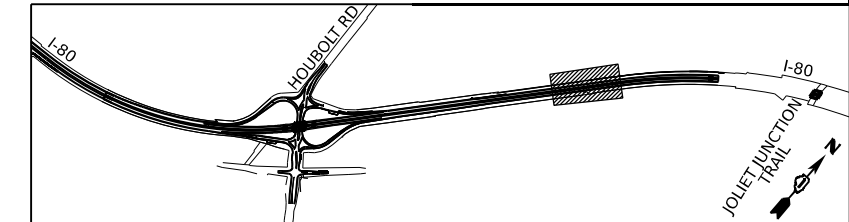

MODEL: BL\_P0\_P0 - Plan 8 (Sheet)  
 FILE NAME: P:\Projects\2023\Illinois\Transportation\Comp-pw-Hosted\Documents\Projects\_2018\CH401\401180022\02-TransSystems\CAD\62R27\Figures\05-Road Rem\0162R27\_Removal Sheets



USER NAME = amkluver	DESIGNED - VLJ	REVISED -
PLOT SCALE = 0.16666633 1/ in.	DRAWN - AMK	REVISED -
PLOT DATE = 6/23/2023	CHECKED - JMG	REVISED -
	DATE - 6/26/23	REVISED -

**STATE OF ILLINOIS  
DEPARTMENT OF TRANSPORTATION**





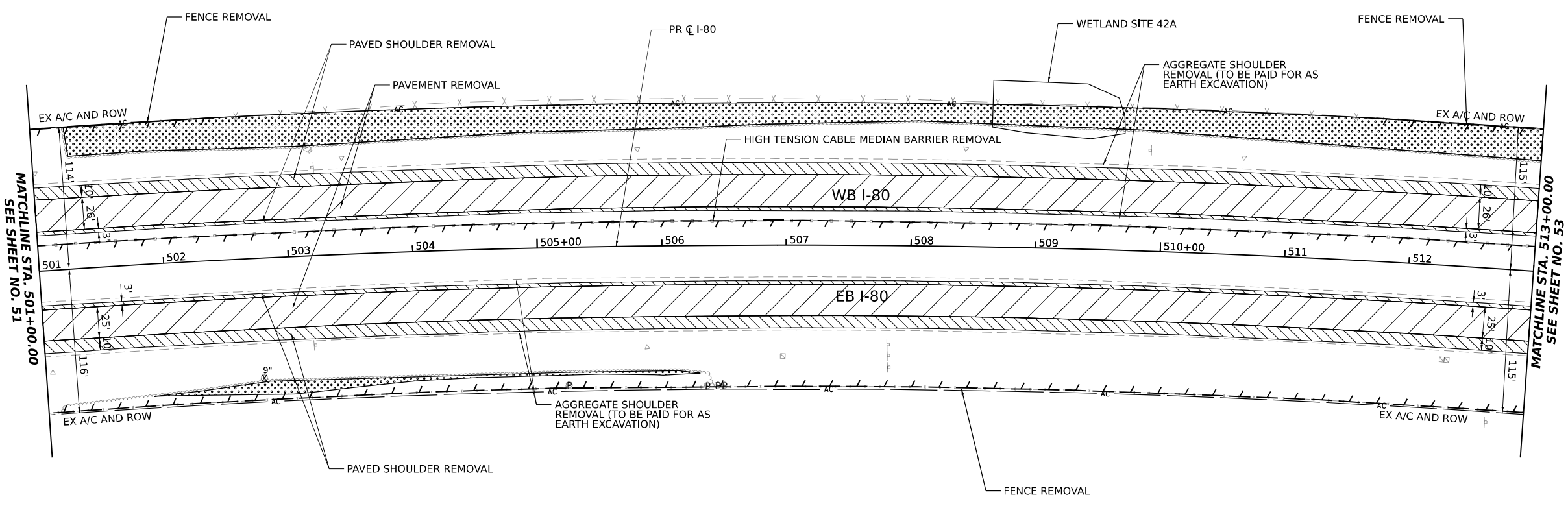
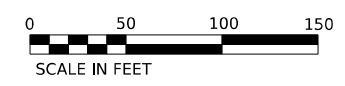
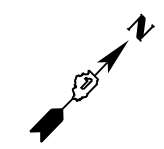

**REMOVAL PLAN**

SCALE: 1"=50'    SHEET 8 OF 10 SHEETS    STA. 489+00.00 TO STA. 501+00.00

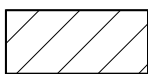
F.A.I. RTE.	SECTION	COUNTY	TOTAL SHEETS	SHEET NO.
I-80	FAI 80 21 STRUCTURE 6	WILL	898	51
CONTRACT NO. 62R27			ILLINOIS   FED. AID PROJECT	

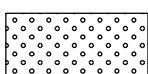

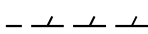
**LEGEND**

-  PAVEMENT REMOVAL
-  APPROACH SLAB REMOVAL
-  PAVED SHOULDER REMOVAL
-  TREE REMOVAL, ACRES
-  TREE REMOVAL, ACRES (SPECIAL)  
WEED CONTROL, NATIVE  
LANDSCAPE ENHANCEMENT
-  LINEAR REMOVAL
-  TREE REMOVAL
-  TREE TRUNK PROTECTION,  
TREE ROOT PRUNING &  
TREE PRUNING.

**NOTES:**

1. SEE ALIGNMENT AND TIES SHEETS FOR CURVE DATA.
2. ALL STATION AND OFFSETS ARE MEASURED FROM PR C I-80 UNLESS OTHERWISE NOTED.
3. SEE EROSION CONTROL PLANS FOR TEMPORARY FENCE BETWEEN TREE REMOVAL, ACRES AND TREE REMOVAL, ACRES (SPECIAL).

**KEY PLAN**

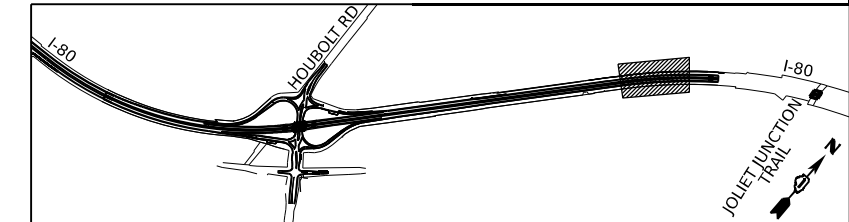

MODEL: BL\_IPD\_00 - Plan 9 (Sheet)  
 FILE NAME: \\p01\transys\compt\transys\comppw\homedocuments\projects\_2018\CH401\401180022\02-TransSystems\CAD\62R27\Structs\05-Road Rem\0162R27\_Removal Sheets



USER NAME = amkluver	DESIGNED - VLJ	REVISED -
PLOT SCALE = 0.16666633 1/ in.	DRAWN - AMK	REVISED -
PLOT DATE = 6/23/2023	CHECKED - JMG	REVISED -
	DATE - 6/26/23	REVISED -

**STATE OF ILLINOIS  
DEPARTMENT OF TRANSPORTATION**

**REMOVAL PLAN**

SCALE: 1"=50'      SHEET 9 OF 10 SHEETS      STA. 501+00.00 TO STA. 513+00.00

F.A.I. RTE.	SECTION	COUNTY	TOTAL SHEETS	SHEET NO.
I-80	FAI 80 21 STRUCTURE 6	WILL	898	52
			CONTRACT NO. 62R27	
		ILLINOIS	FED. AID PROJECT	

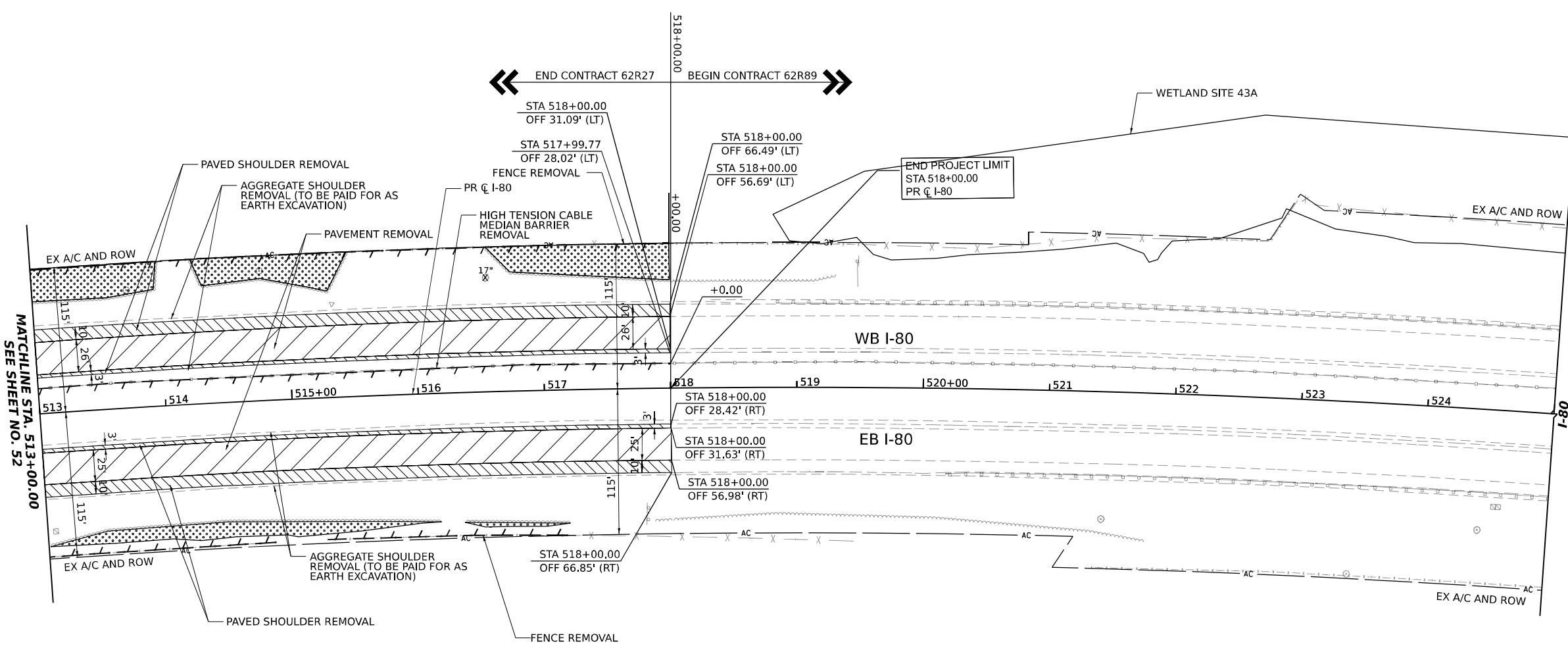
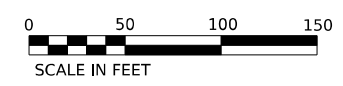

MATCHLINE STA. 513+00.00  
SEE SHEET NO. 52

**LEGEND**

- PAVEMENT REMOVAL
- APPROACH SLAB REMOVAL
- PAVED SHOULDER REMOVAL
- TREE REMOVAL, ACRES
- TREE REMOVAL, ACRES (SPECIAL)  
WEED CONTROL, NATIVE  
LANDSCAPE ENHANCEMENT
- LINEAR REMOVAL
- TREE REMOVAL
- TREE TRUNK PROTECTION,  
TREE ROOT PRUNING &  
TREE PRUNING.

**NOTES:**

1. SEE ALIGNMENT AND TIES SHEETS FOR CURVE DATA.
2. ALL STATION AND OFFSETS ARE MEASURED FROM PR C I-80 UNLESS OTHERWISE NOTED.
3. SEE EROSION CONTROL PLANS FOR TEMPORARY FENCE BETWEEN TREE REMOVAL, ACRES AND TREE REMOVAL, ACRES (SPECIAL).

**KEY PLAN**

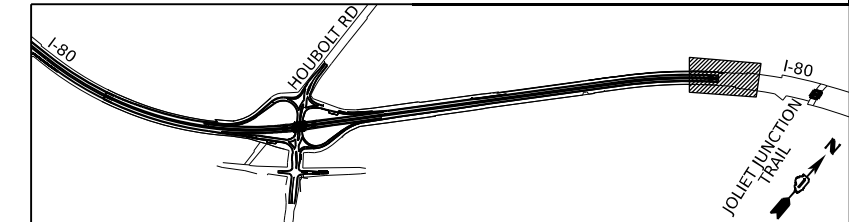

MODEL: BL\_PR\_00 - Plan 10 (Sheet)  
FILE NAME: P:\Projects\Illinois\Transportation\Comp-pw-Hosted\Documents\Projects\_2018\CH401\401180022\02-TrafficSystems\CAD\62R27\Structs\05-Road Rem\03.62R27\_Removal Sheets



USER NAME = amkluver	DESIGNED - VLJ	REVISED -
PLOT SCALE = 0.16666633 1/16 in.	DRAWN - AMK	REVISED -
PLOT DATE = 6/23/2023	CHECKED - JMG	REVISED -
	DATE - 6/26/23	REVISED -

**STATE OF ILLINOIS  
DEPARTMENT OF TRANSPORTATION**

**REMOVAL PLAN**

SCALE: 1"=50'      SHEET 10 OF 10 SHEETS      STA. 513+00.00 TO STA. 518+00.00

F.A.I. RTE.	SECTION	COUNTY	TOTAL SHEETS	SHEET NO.
I-80	FAI 80 21 STRUCTURE 6	WILL	898	53
CONTRACT NO. 62R27				
ILLINOIS   FED. AID PROJECT				



**NOTES:**

1. SEE ALIGNMENT AND TIES SHEETS FOR CURVE DATA.
2. ALL STATION AND OFFSET MEASURED FROM PR CL I-80 UNLESS OTHERWISE NOTED.
3. MEDIAN CONCRETE BARRIER AND CONCRETE BARRIER BASE TO BE OMITTED AT MEDIAN LIGHT POLE FOUNDATIONS. SEE LIGHTING PLANS FOR MORE INFORMATION.

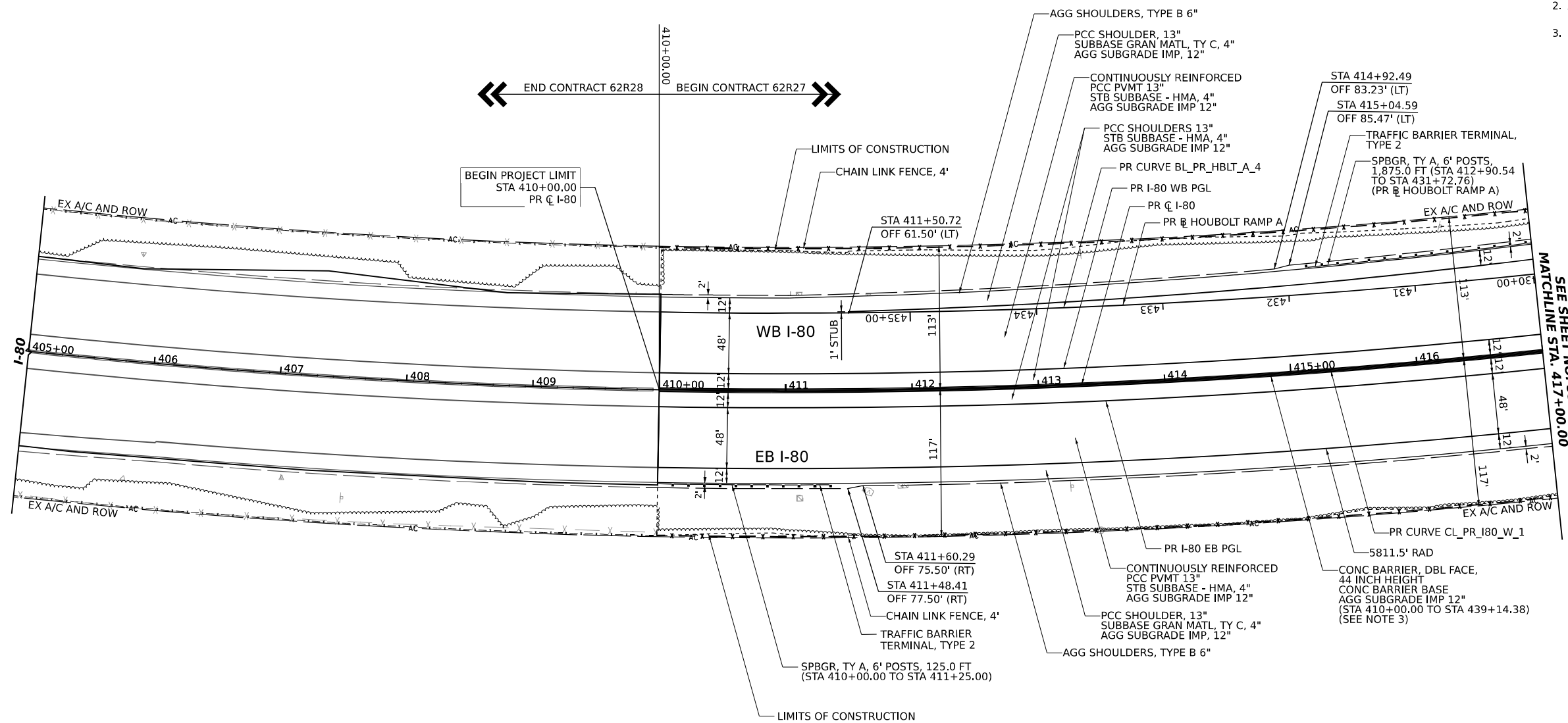

**KEY PLAN**

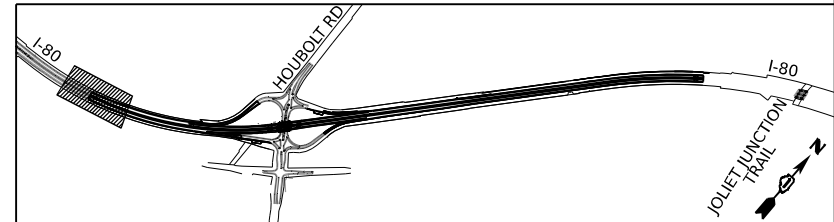

MODEL: BL\_PR\_I80\_Plan\_1 (Sheet)  
 FILE NAME: P:\Projects\Illinois\Projects\2018\CI-401\401180022\02-TransSystems\CAD\62R27\Sheets\06-Road Plan Profile\01I8027\_Plan\_Sheets



USER NAME = amkluver	DESIGNED - VLJ	REVISED -
PLOT SCALE = 0.16666633 1/ in.	DRAWN - AMK	REVISED -
PLOT DATE = 6/23/2023	CHECKED - JMG	REVISED -
	DATE - 11/11/22	REVISED -

**STATE OF ILLINOIS  
DEPARTMENT OF TRANSPORTATION**

<b>ROADWAY PLAN</b>		
<b>I-80</b>		
SCALE: 1"=50'	SHEET 1	OF 10 SHEETS
STA. 411+50.00	TO STA. 417+00.00	

F.A.P. RTE. I-80	SECTION FAI 80 21 STRUCTURE 6	COUNTY WILL	TOTAL SHEETS 898	SHEET NO. 54
CONTRACT NO. 62R27				
ILLINOIS   FED. AID PROJECT				



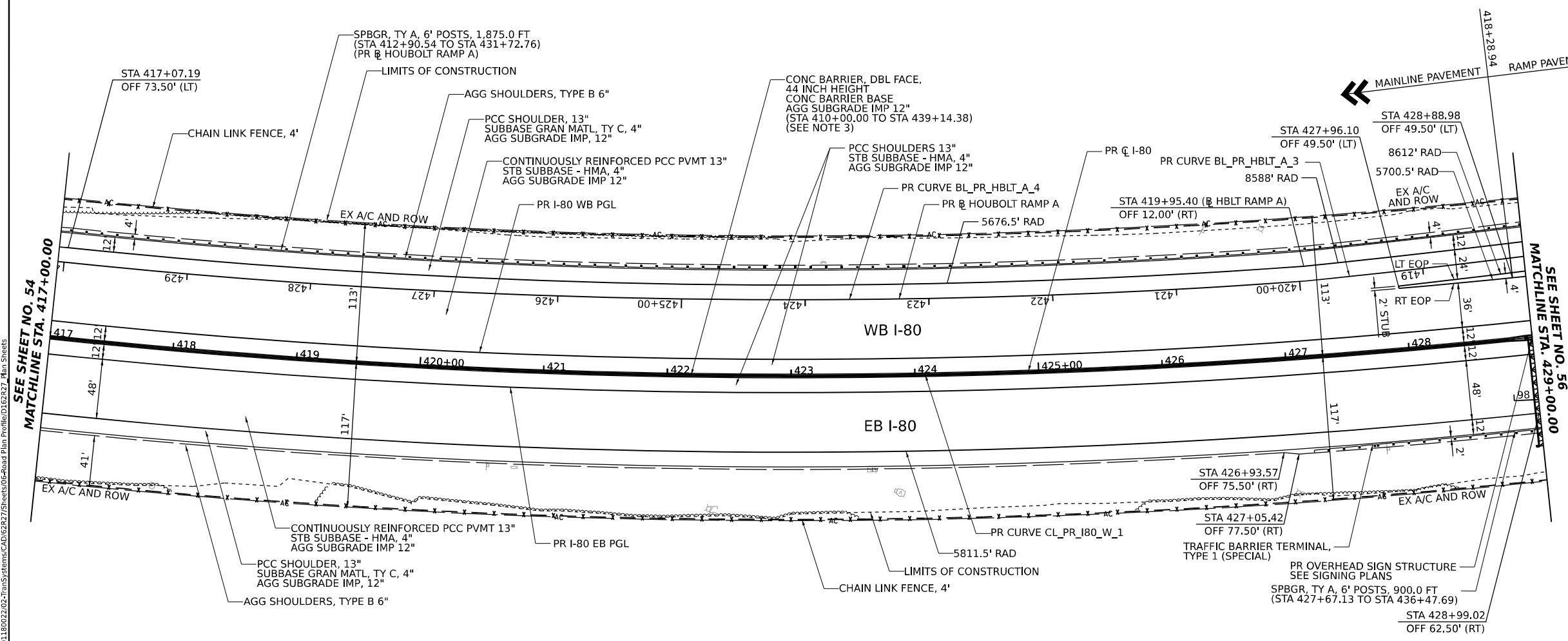
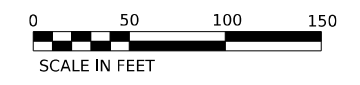

**NOTES:**

1. SEE ALIGNMENT AND TIES SHEETS FOR CURVE DATA.
2. ALL STATION AND OFFSET MEASUREDD FROM PR CL I-80 UNLESS OTHERWISE NOTED.
3. MEDIAN CONCRETE BARRIER AND CONCRETE BARRIER BASE TO BE OMITTED AT MEDIAN LIGHT POLE FOUNDATIONS. SEE LIGHTING PLANS FOR MORE INFORMATION.

**KEY PLAN**

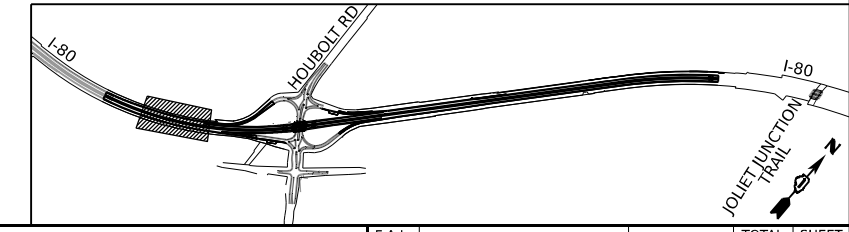

MODEL: BL\_PR\_I80\_Plan\_2 (Sheet)  
 FILE NAME: P:\Projects\Illinois\Projects\2018\CH401\401\80022\02-TransSystems\CAD\2022\Sheets\06-Road Plan Profile\012327\_Rln\_Sheets



USER NAME = amkluver	DESIGNED - VLJ	REVISED -
PLOT SCALE = 0.16666633 1/ in.	DRAWN - AMK	REVISED -
PLOT DATE = 6/23/2023	CHECKED - JMG	REVISED -
	DATE - 11/11/22	REVISED -

**STATE OF ILLINOIS  
DEPARTMENT OF TRANSPORTATION**

<b>ROADWAY PLAN</b>	
<b>I-80</b>	
SCALE: 1"=50'	SHEET 2 OF 10 SHEETS
STA. 417+00.00	TO STA. 429+00.00

F.A.I. RTE.	SECTION	COUNTY	TOTAL SHEETS	SHEET NO.
I-80	FAI 80 21 STRUCTURE 6	WILL	898	55
ILLINOIS			CONTRACT NO. 62R27	
FED. AID PROJECT				

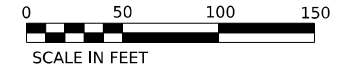
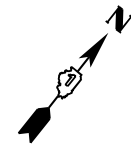

**NOTES:**

1. SEE ALIGNMENT AND TIES SHEETS FOR CURVE DATA.
2. ALL STATION AND OFFSET MEASURED FROM PR CL I-80 UNLESS OTHERWISE NOTED.
3. MEDIAN CONCRETE BARRIER AND CONCRETE BARRIER BASE TO BE OMITTED AT MEDIAN LIGHT POLE FOUNDATIONS. SEE LIGHTING PLANS FOR MORE INFORMATION.

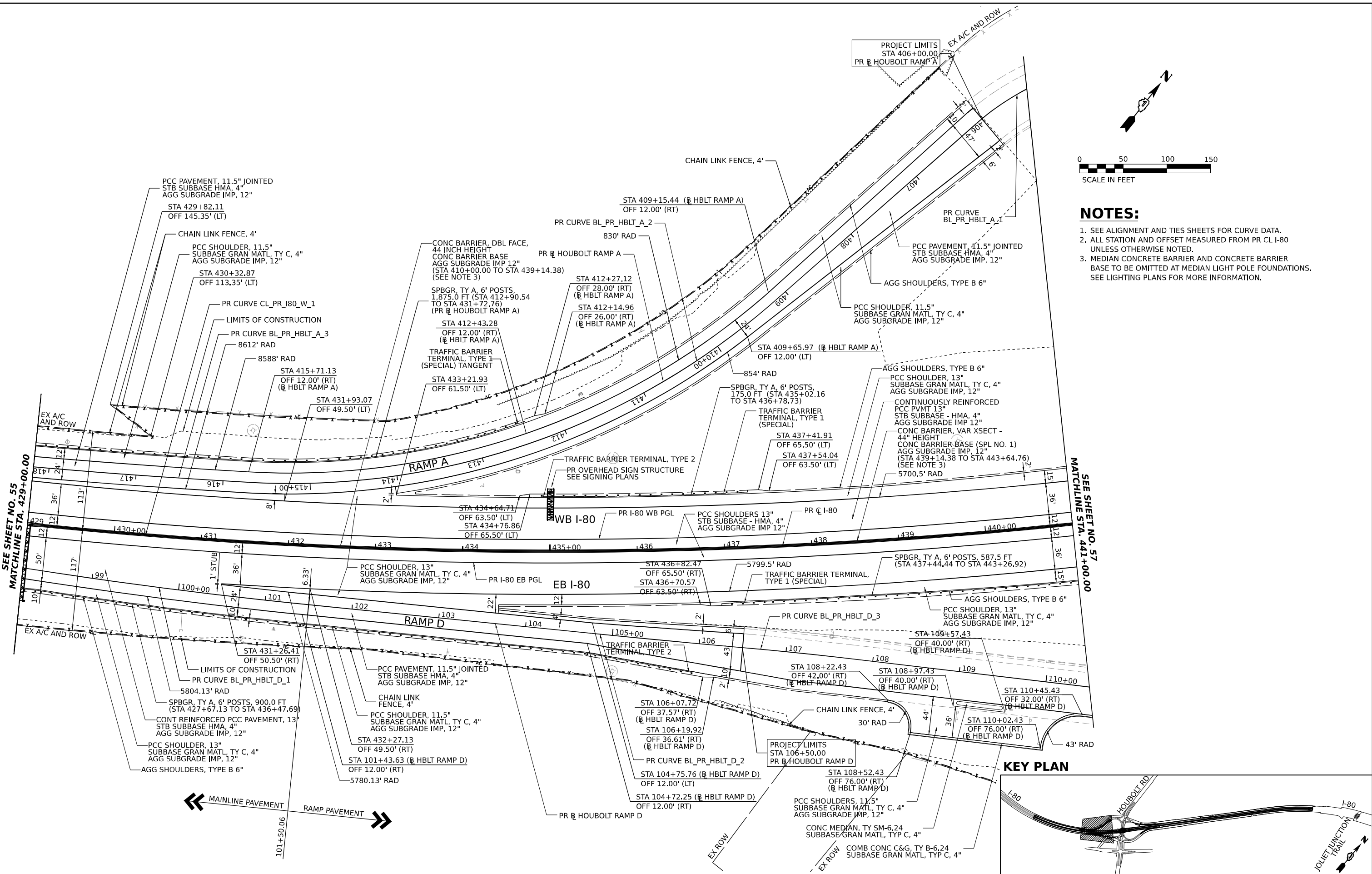

MODEL: BL\_PR\_I80\_Plan\_3 (Sheet)  
 FILE NAME: P:\Projects\2023\2023-06-27\TransSystems\CAD\62R27\Struct\06-Road\_Plan\_Profile\02\2327\_Rln\_Sheets



USER NAME = amkluver	DESIGNED - VLJ	REVISED -
DRAWN - AMK	REVISED -	
CHECKED - JMG	REVISED -	
DATE - 11/11/22	REVISED -	

**STATE OF ILLINOIS  
DEPARTMENT OF TRANSPORTATION**

<b>ROADWAY PLAN</b>	
<b>I-80</b>	
SCALE: 1"=50'	SHEET 3 OF 10 SHEETS
STA. 429+00.00	TO STA. 441+00.00

F.A.I. RTE.	SECTION	COUNTY	TOTAL SHEETS	SHEET NO.
I-80	FAI 80 21 STRUCTURE 6	WILL	898	56
CONTRACT NO. 62R27			ILLINOIS   FED. AID PROJECT	

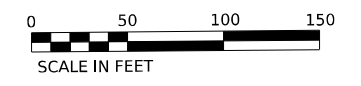
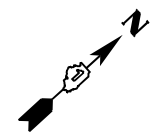

**NOTES:**

1. SEE ALIGNMENT AND TIES SHEETS FOR CURVE DATA.
2. ALL STATION AND OFFSET MEASURED FROM PR CL I-80 UNLESS OTHERWISE NOTED.
3. MEDIAN CONCRETE BARRIER AND CONCRETE BARRIER BASE TO BE OMITTED AT MEDIAN LIGHT POLE FOUNDATIONS SEE LIGHTING PLANS FOR MORE INFORMATION.

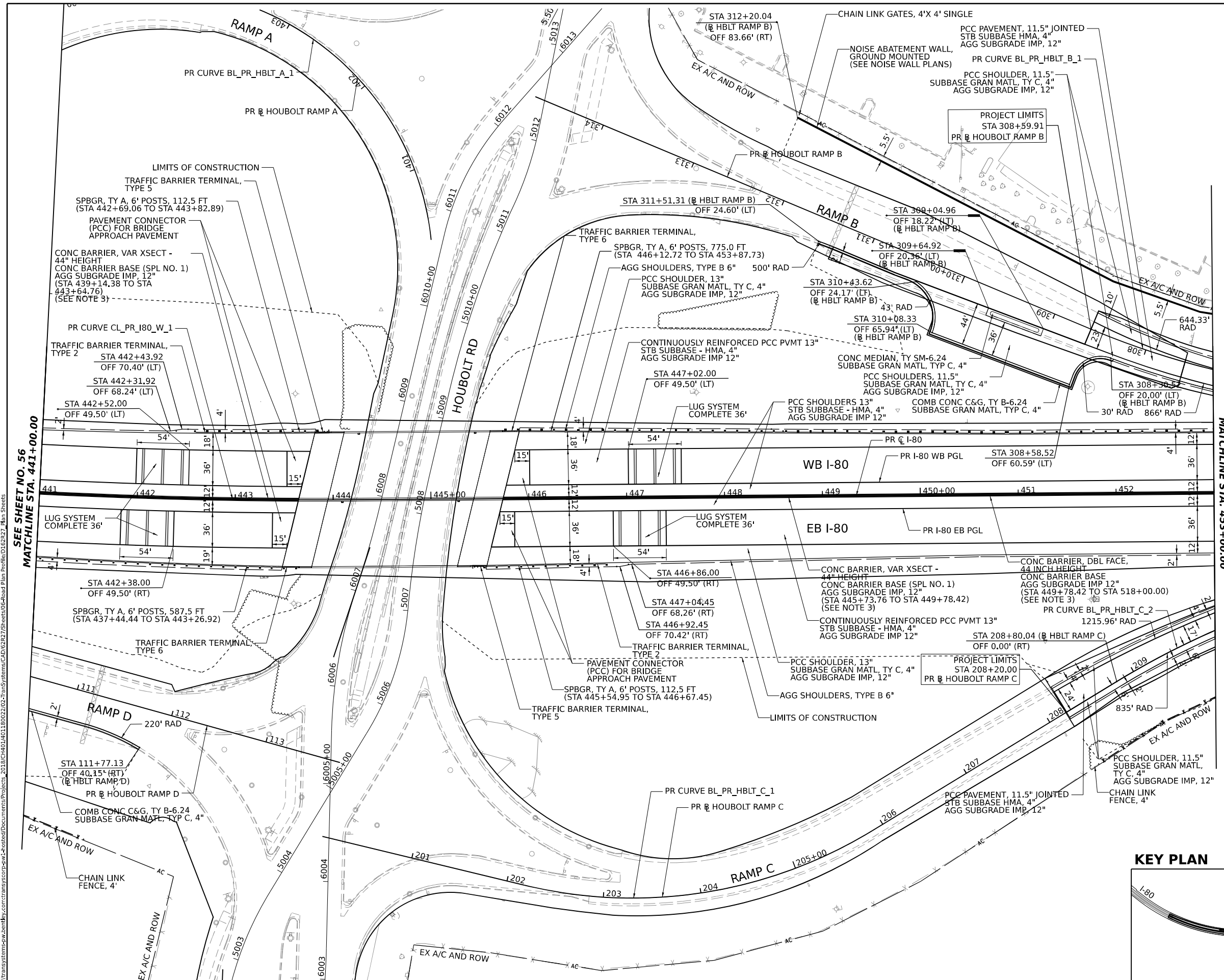

SEE SHEET NO. 56  
MATCHLINE STA. 441+00.00

SEE SHEET NO. 58  
MATCHLINE STA. 453+00.00

**KEY PLAN**

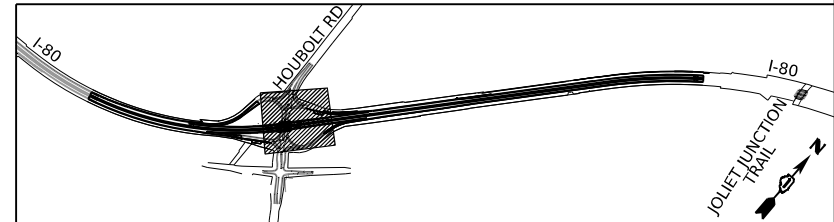

MODEL: BL\_PR\_I80\_Plan\_1 (Sheet)  
FILE NAME: P:\Projects\2022\2022-02-27\TransSystems\CAD\2022\2022-02-27\Struct\06-Road\_Plan\_Profile\02-27-22\_Bldg\_Sheets



USER NAME = amkluver	DESIGNED - VLJ	REVISED -
PLOT SCALE = 0.16666633 1/16"	DRAWN - AMK	REVISED -
PLOT DATE = 7/27/2023	CHECKED - JMG	REVISED -
	DATE - 7/28/23	REVISED -

**STATE OF ILLINOIS  
DEPARTMENT OF TRANSPORTATION**

**ROADWAY PLAN  
I-80**

SCALE: 1"=50' SHEET 4 OF 10 SHEETS STA. 441+00.00 TO STA. 453+00.00

F.A.I. RTE.	SECTION	COUNTY	TOTAL SHEETS	SHEET NO.
I-80	FAI 80 21 STRUCTURE 6	WILL	898	57
CONTRACT NO. 62R27				
ILLINOIS FED. AID PROJECT				

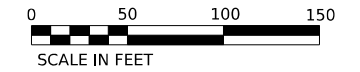
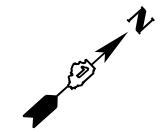

**NOTES:**

1. SEE ALIGNMENT AND TIES SHEETS FOR CURVE DATA.
2. ALL STATION AND OFFSET MEASURED FROM PR CL I-80 UNLESS OTHERWISE NOTED.
3. MEDIAN CONCRETE BARRIER AND CONCRETE BARRIER BASE TO BE OMITTED AT MEDIAN LIGHT POLE FOUNDATIONS. SEE LIGHTING PLANS FOR MORE INFORMATION.

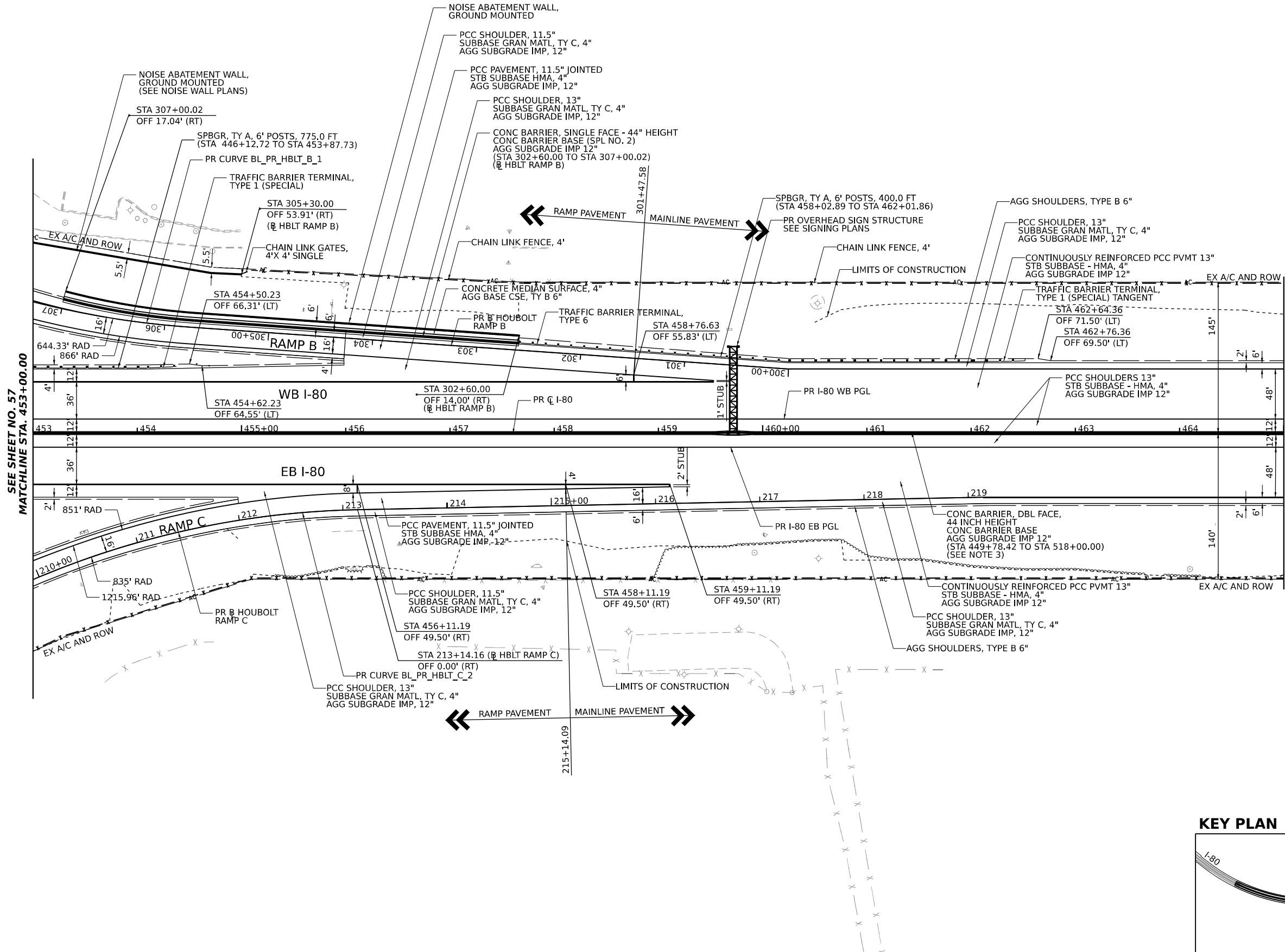

SEE SHEET NO. 57  
MATCHLINE STA. 453+00.00

MATCHLINE STA. 465+00.00  
SEE SHEET NO. 59

**KEY PLAN**

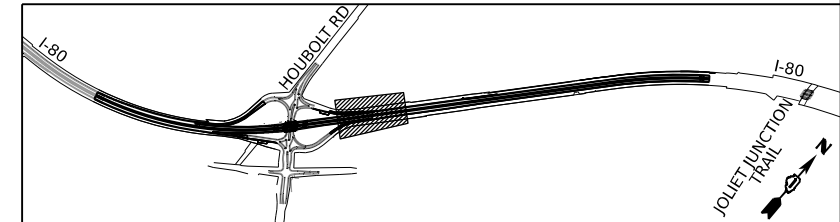

MODEL: BL\_PR\_I80\_Plan\_3 (Sheet)  
FILE NAME: P:\Projects\2022\2022-02-TransSystems\CAD\2022\2022-02-TransSystems\Road Plan Profile\02-27-22\Road Plan Profile\02-27-22\_Rln\_Sheets



USER NAME = amkluver	DESIGNED - VLJ	REVISED -
PLOT SCALE = 0.16666633 1/16"	DRAWN - AMK	REVISED -
PLOT DATE = 7/27/2023	CHECKED - JMG	REVISED -
	DATE - 7/28/23	REVISED -

**STATE OF ILLINOIS  
DEPARTMENT OF TRANSPORTATION**

**ROADWAY PLAN**  
**I-80**

SCALE: 1"=50'    SHEET 5 OF 10 SHEETS    STA. 453+00.00 TO STA. 465+00.00

F.A.I. RTE.	SECTION	COUNTY	TOTAL SHEETS	SHEET NO.
I-80	FAI 80 21 STRUCTURE 6	WILL	898	58
CONTRACT NO. 62R27				
ILLINOIS   FED. AID PROJECT				

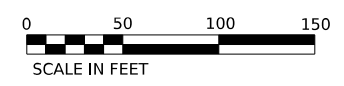
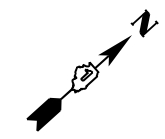

**NOTES:**

1. SEE ALIGNMENT AND TIES SHEETS FOR CURVE DATA.
2. ALL STATION AND OFFSET MEASURED FROM PR CL I-80 UNLESS OTHERWISE NOTED.
3. MEDIAN CONCRETE BARRIER AND CONCRETE BARRIER BASE TO BE OMITTED AT MEDIAN LIGHT POLE FOUNDATIONS. SEE LIGHTING PLANS FOR MORE INFORMATION.

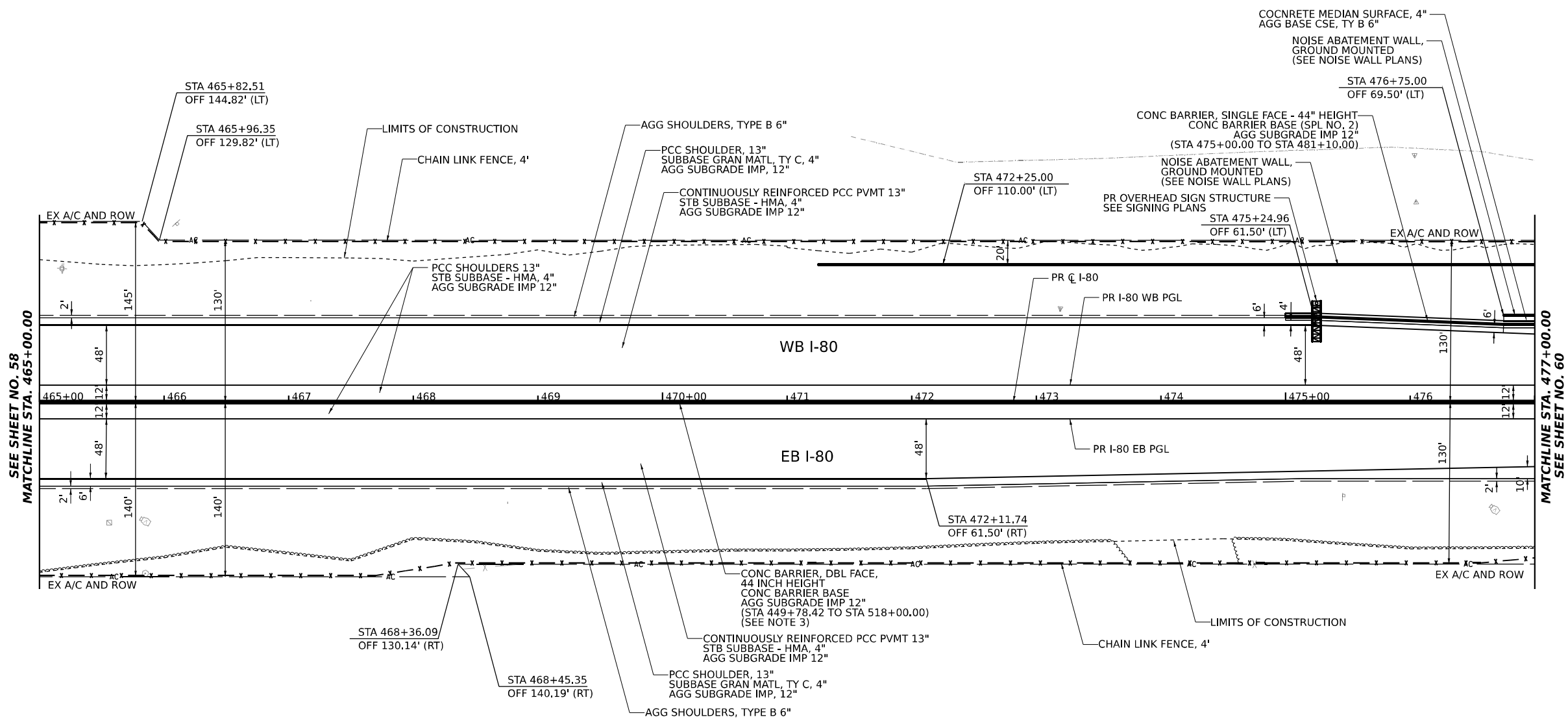

SEE SHEET NO. 58  
MATCHLINE STA. 465+00.00

MATCHLINE STA. 477+00.00  
SEE SHEET NO. 60

**KEY PLAN**

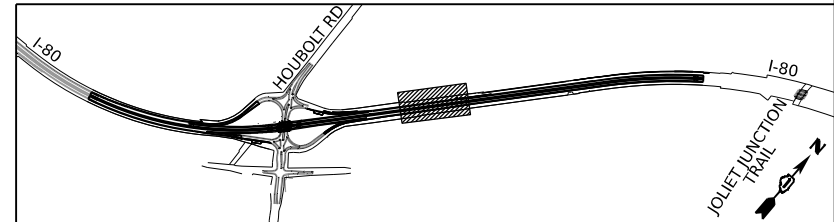

MODEL: I-80\_Plan\_6 (Sheet)  
 FILE NAME: P:\Projects\Illinois\Transportation\I-80\Drawings\Roadway\I-80\_Plan\_6.dwg  
 PROJECT: I-80 Structure 6  
 DATE: 11/11/22



USER NAME = amkluver	DESIGNED - VLJ	REVISED -
DRAWN - AMK	REVISIONS -	
PLOT SCALE = 0.16666633 1/16"	CHECKED - JMG	REVISED -
PLOT DATE = 6/23/2023	DATE - 11/11/22	REVISED -

**STATE OF ILLINOIS  
DEPARTMENT OF TRANSPORTATION**

<b>ROADWAY PLAN</b>			
<b>I-80</b>			
SCALE: 1"=50'	SHEET 6	OF 10 SHEETS	STA. 465+00.00 TO STA. 477+00.00

F.A.I. RTE.	SECTION	COUNTY	TOTAL SHEETS	SHEET NO.
I-80	FAI 80 21 STRUCTURE 6	WILL	898	59
CONTRACT NO. 62R27				
ILLINOIS FED. AID PROJECT				

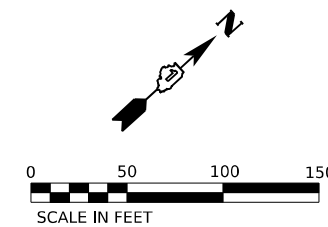

**NOTES:**

1. SEE ALIGNMENT AND TIES SHEETS FOR CURVE DATA.
2. ALL STATION AND OFFSET MEASURED FROM PR CL I-80 UNLESS OTHERWISE NOTED.
3. MEDIAN CONCRETE BARRIER AND CONCRETE BARRIER BASE TO BE OMITTED AT MEDIAN LIGHT POLE FOUNDATIONS. SEE LIGHTING PLANS FOR MORE INFORMATION.

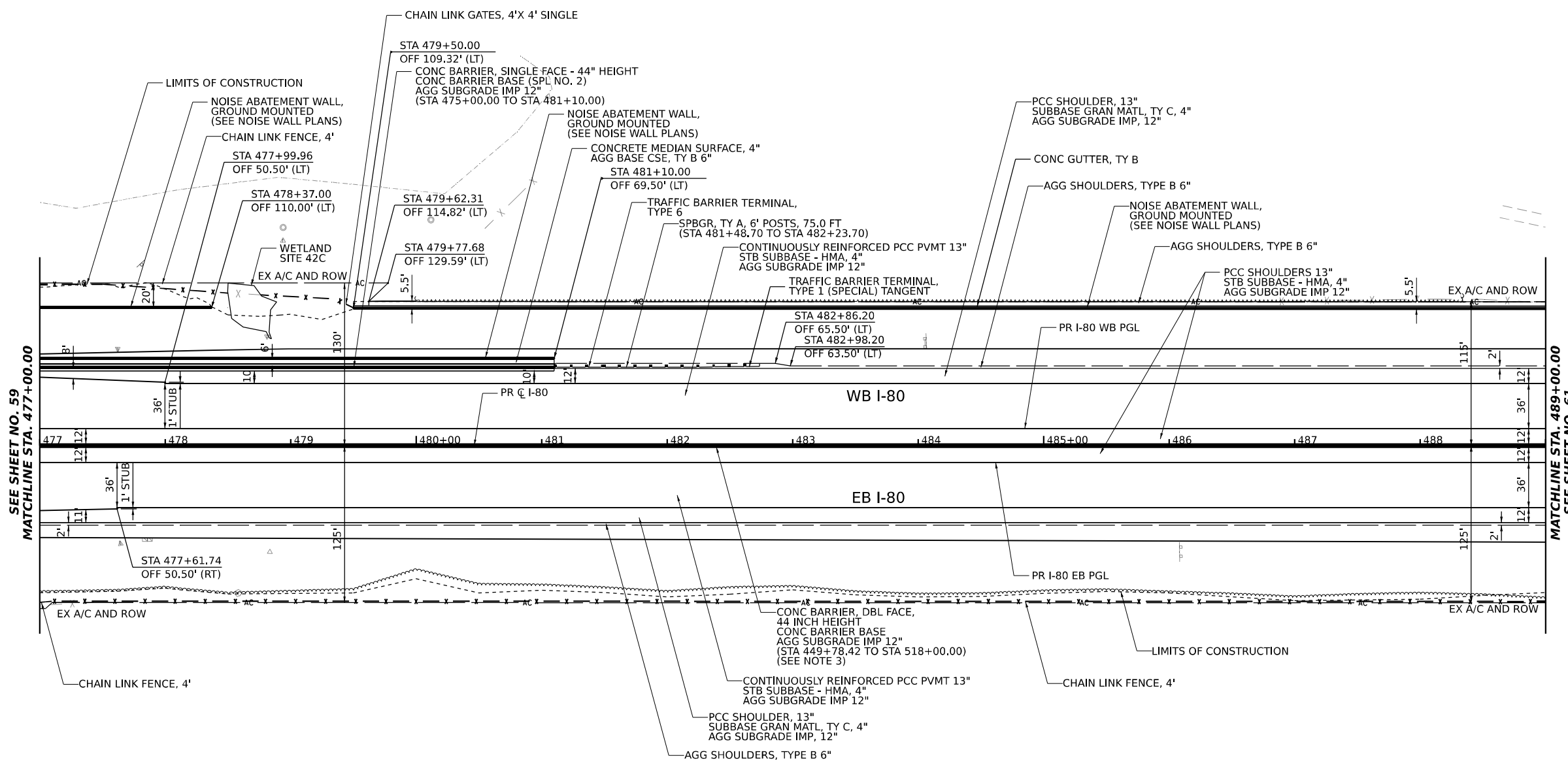

SEE SHEET NO. 59  
MATCHLINE STA. 477+00.00

MATCHLINE STA. 489+00.00  
SEE SHEET NO. 61

**KEY PLAN**

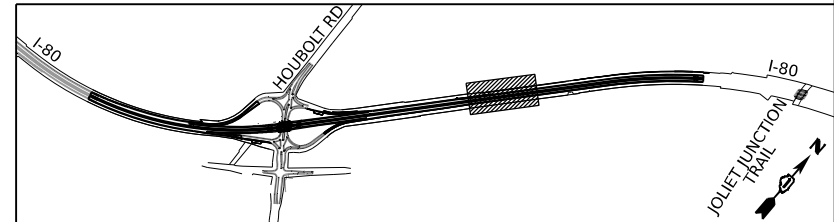

MODEL: BL\_I80\_Plan 7 (Sheet)  
 FILE NAME: P:\Projects\Illinois\Projects\2018\01\401\180022\02-TransSystems\CAD\2022\Drawings\Road\Plan\Profile\022227\Drawings\06-Road\Road\Plan\Profile\022227\_Rln\_Sheets



USER NAME = amkluver	DESIGNED - VLJ	REVISED -
DRAWN - AMK	REVISIONS -	
PLOT SCALE = 0.16666633 1/16 in.	CHECKED - JMG	REVISED -
PLOT DATE = 7/27/2023	DATE - 7/28/23	REVISED -

**STATE OF ILLINOIS  
DEPARTMENT OF TRANSPORTATION**

**ROADWAY PLAN  
I-80**  
SCALE: 1"=50' SHEET 7 OF 10 SHEETS STA. 477+00.00 TO STA. 489+00.00

F.A.I. RTE.	SECTION	COUNTY	TOTAL SHEETS	SHEET NO.
I-80	FAI 80 21 STRUCTURE 6	WILL	898	60
CONTRACT NO. 62R27				
ILLINOIS FED. AID PROJECT				

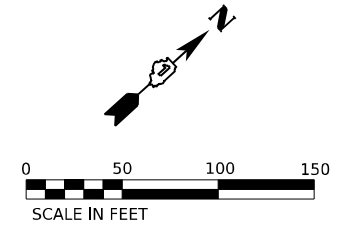

**NOTES:**

1. SEE ALIGNMENT AND TIES SHEETS FOR CURVE DATA.
2. ALL STATION AND OFFSET MEASURED FROM PR CL I-80 UNLESS OTHERWISE NOTED.
3. MEDIAN CONCRETE BARRIER AND CONCRETE BARRIER BASE TO BE OMITTED AT MEDIAN LIGHT POLE FOUNDATIONS. SEE LIGHTING PLANS FOR MORE INFORMATION.

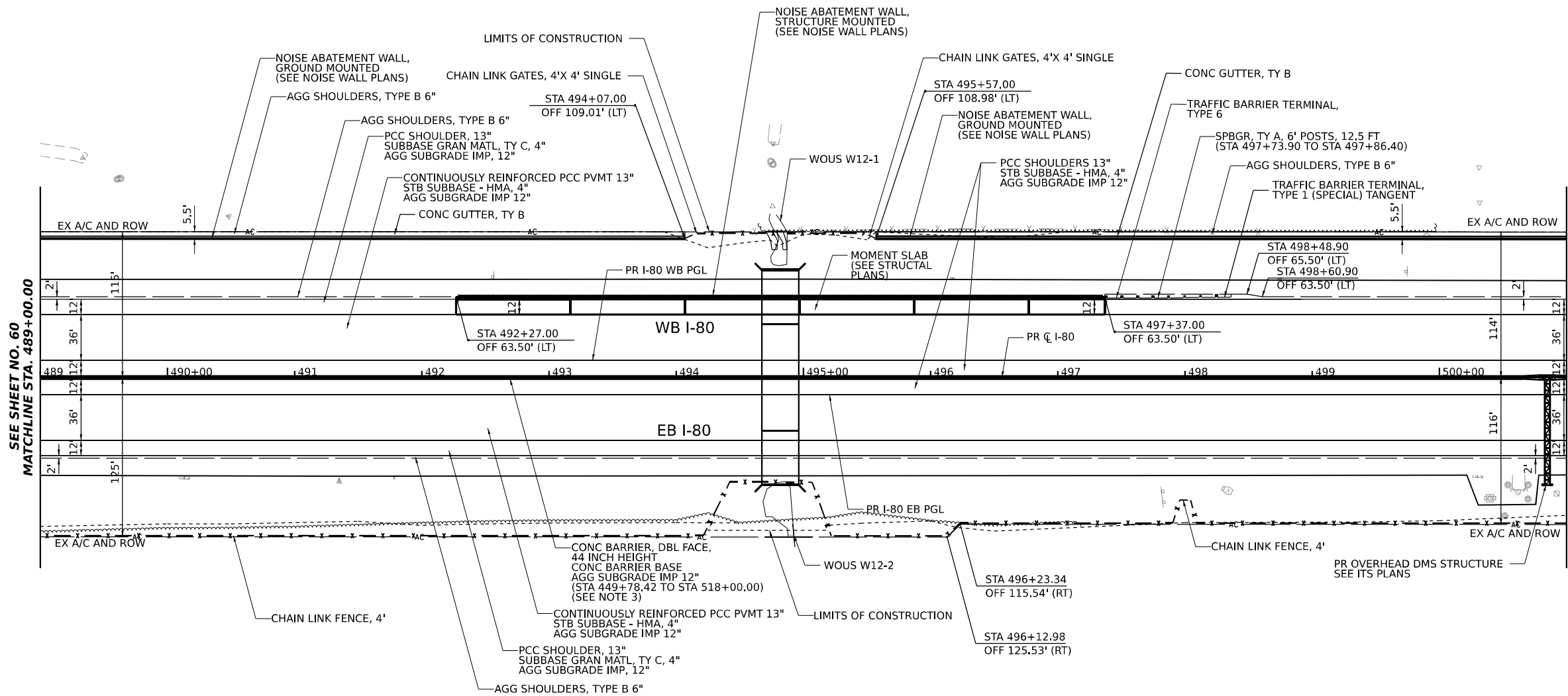

SEE SHEET NO. 60  
MATCHLINE STA. 489+00.00

MATCHLINE STA. 501+00.00  
SEE SHEET NO. 62

**KEY PLAN**

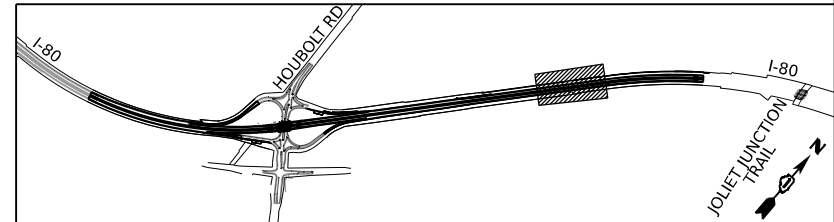

MODEL: I-80 - Plan 8 (Sheet)  
 FILE NAME: P:\Projects\2023\Illinois\Transportation\I-80\Drawings\Roadway\Roadway\I-80\I-80\_Plan\_8.dwg  
 PROJECT: I-80 Structure 6  
 DATE: 7/27/2023



USER NAME = amkluver	DESIGNED - VLJ	REVISED -
PLOT SCALE = 0.16666633 1/16 in.	DRAWN - AMK	REVISED -
PLOT DATE = 7/27/2023	CHECKED - JMG	REVISED -
	DATE - 7/28/23	REVISED -

**STATE OF ILLINOIS  
DEPARTMENT OF TRANSPORTATION**

**ROADWAY PLAN  
I-80**

SCALE: 1"=50'    SHEET 8 OF 10 SHEETS    STA. 489+00.00 TO STA. 501+00.00

F.A.I. RTE.	SECTION	COUNTY	TOTAL SHEETS	SHEET NO.
I-80	FAI 80 21 STRUCTURE 6	WILL	898	61
CONTRACT NO. 62R27				
ILLINOIS FED. AID PROJECT				

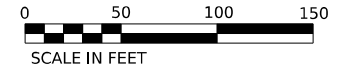
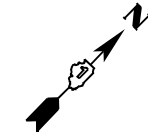

**NOTES:**

- 1. SEE ALIGNMENT AND TIES SHEETS FOR CURVE DATA.
- 2. ALL STATION AND OFFSET MEASURED FROM PR CL I-80 UNLESS OTHERWISE NOTED.
- 3. MEDIAN CONCRETE BARRIER AND CONCRETE BARRIER BASE TO BE OMITTED AT MEDIAN LIGHT POLE FOUNDATIONS. SEE LIGHTING PLANS FOR MORE INFORMATION.

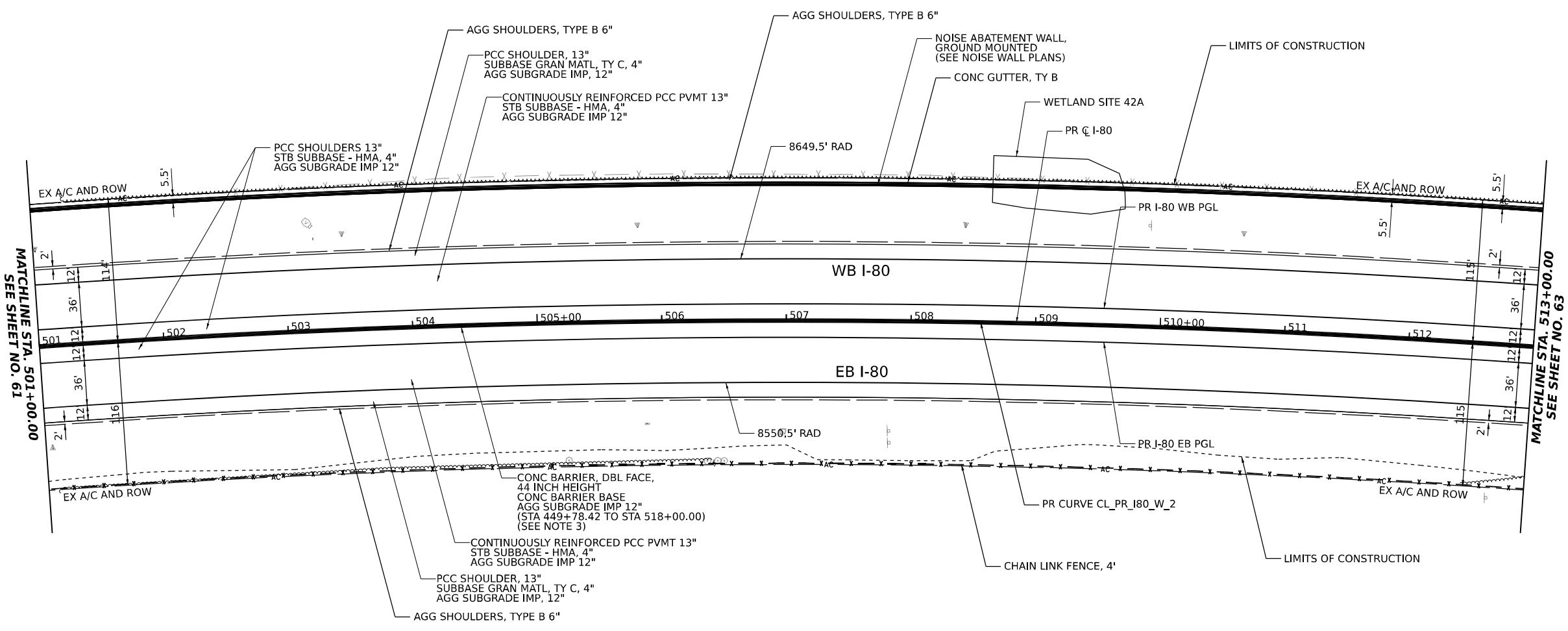

MATCHLINE STA. 501+00.00  
SEE SHEET NO. 61

MATCHLINE STA. 513+00.00  
SEE SHEET NO. 63

**KEY PLAN**

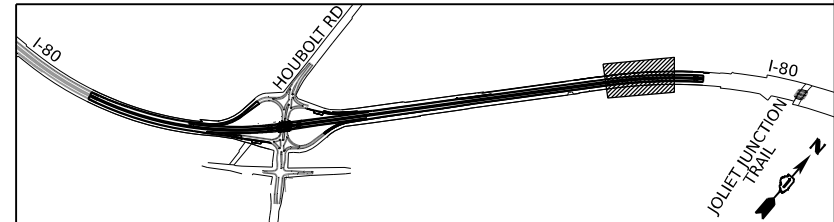

MODEL: BL\_PR\_I80 - Plan 9 (Sheet)  
FILE NAME: P:\transystems\p\client\transystems\comp\pw-1\sheet\Documents\Projects\_2018\C401401180022\02-Transystems\CAD\2227\Drawings\06-Road\_Plan\_Profile\012227\_Rln\_Sheets



USER NAME = amkluver	DESIGNED - VLJ	REVISED -
DRAWN - AMK	REVISED -	
PLOT SCALE = 0.16666633 1/ in.	CHECKED - JMG	REVISED -
PLOT DATE = 6/23/2023	DATE - 11/11/22	REVISED -

**STATE OF ILLINOIS  
DEPARTMENT OF TRANSPORTATION**

**ROADWAY PLAN  
I-80**

SCALE: 1"=50'    SHEET 9 OF 10 SHEETS    STA. 501+00.00 TO STA. 513+00.00

F.A.I. RTE.	SECTION	COUNTY	TOTAL SHEETS	SHEET NO.
I-80	FAI 80 21 STRUCTURE 6	WILL	898	62
CONTRACT NO. 62R27				
ILLINOIS FED. AID PROJECT				



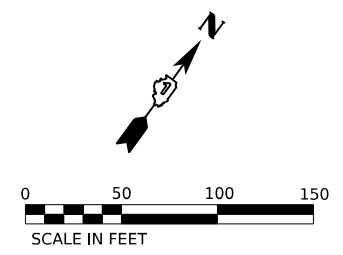

**NOTES:**

1. SEE ALIGNMENT AND TIES SHEETS FOR CURVE DATA.
2. ALL STATION AND OFFSET MEASURED FROM PR CL I-80 UNLESS OTHERWISE NOTED.
3. MEDIAN CONCRETE BARRIER AND CONCRETE BARRIER BASE TO BE OMITTED AT MEDIAN LIGHT POLE FOUNDATIONS. SEE LIGHTING PLANS FOR MORE INFORMATION.

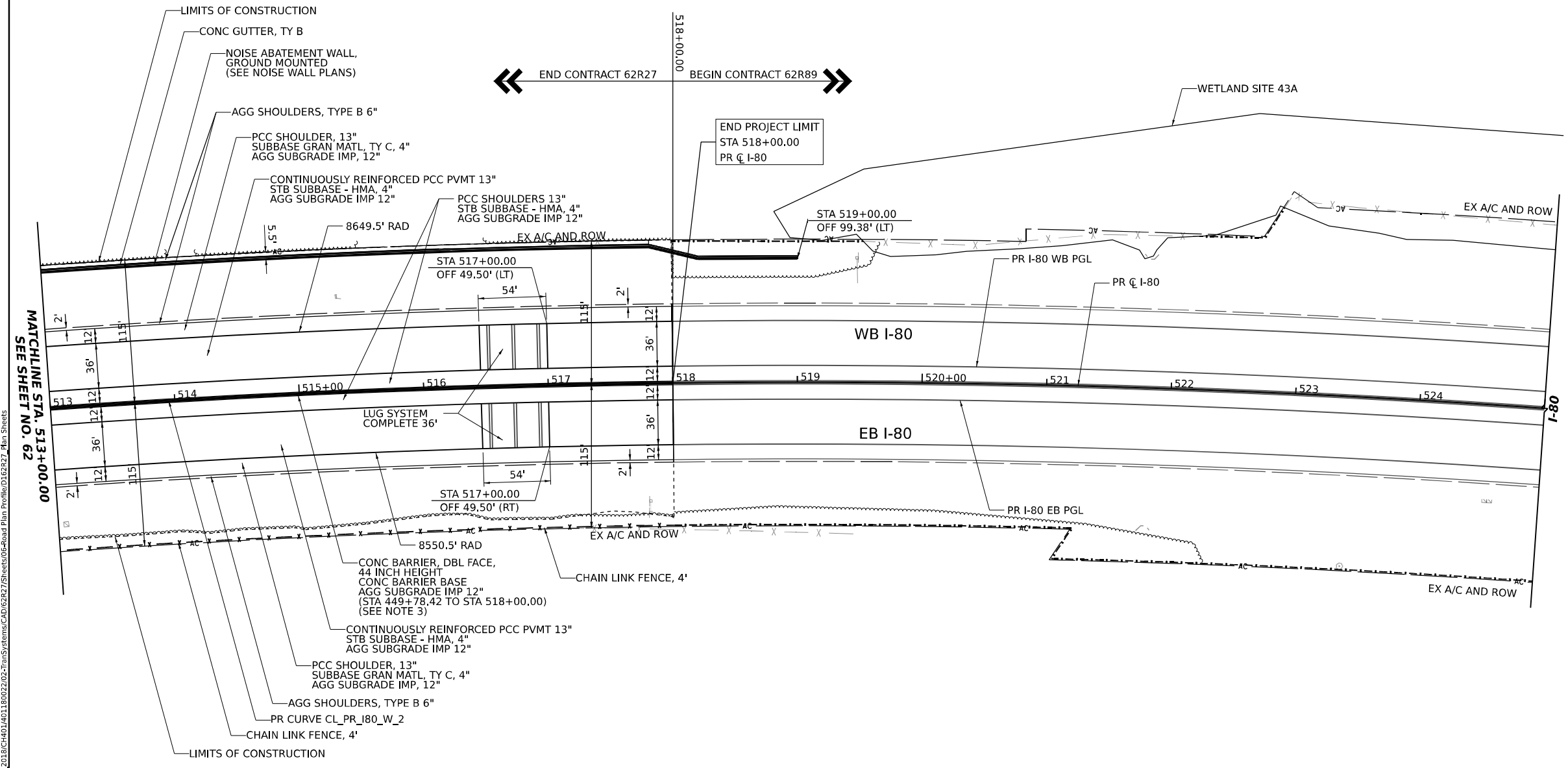

MATCHLINE STA. 513+00.00 SEE SHEET NO. 62

**KEY PLAN**

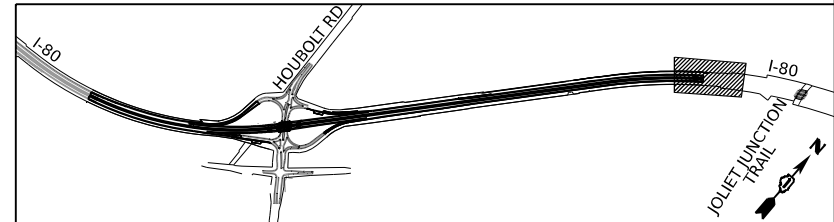

MODEL: BL\_PR\_I80 - Plan 10 (Sheet)  
 FILE NAME: C:\projects\trans\comp\pwr-headers\Documents\Projects\_2018\CH401401180022\02-Trans\Systems\CAD\62R27\Sheets\06-Road\Plan\_Profile\02I80R27\_Rln\_Sheets



USER NAME = amkluver	DESIGNED - VLJ	REVISED -
PLOT SCALE = 0.16666633 1/ in.	DRAWN - AMK	REVISED -
PLOT DATE = 6/23/2023	CHECKED - JMG	REVISED -
	DATE - 11/11/22	REVISED -

**STATE OF ILLINOIS  
 DEPARTMENT OF TRANSPORTATION**

**ROADWAY PLAN  
 I-80**

SCALE: 1"=50'    SHEET 10 OF 10 SHEETS    STA. 513+00.00 TO STA. 518+00.00

F.A.I. RTE.	SECTION	COUNTY	TOTAL SHEETS	SHEET NO.
I-80	FAI 80 21 STRUCTURE 6	WILL	898	63

CONTRACT NO. 62R27

ILLINOIS FED. AID PROJECT

MODEL: PR\_I80\_WB\_WV\_Profile\_1 (Sheet 1)  
 FILE NAME: \\p01\transys\app\transys\transys\p01\transys\transys\CAD\62R27\Sheets\06-Road\Plan Profile\01E2R27\_RoadProfile\_Sheets.dgn

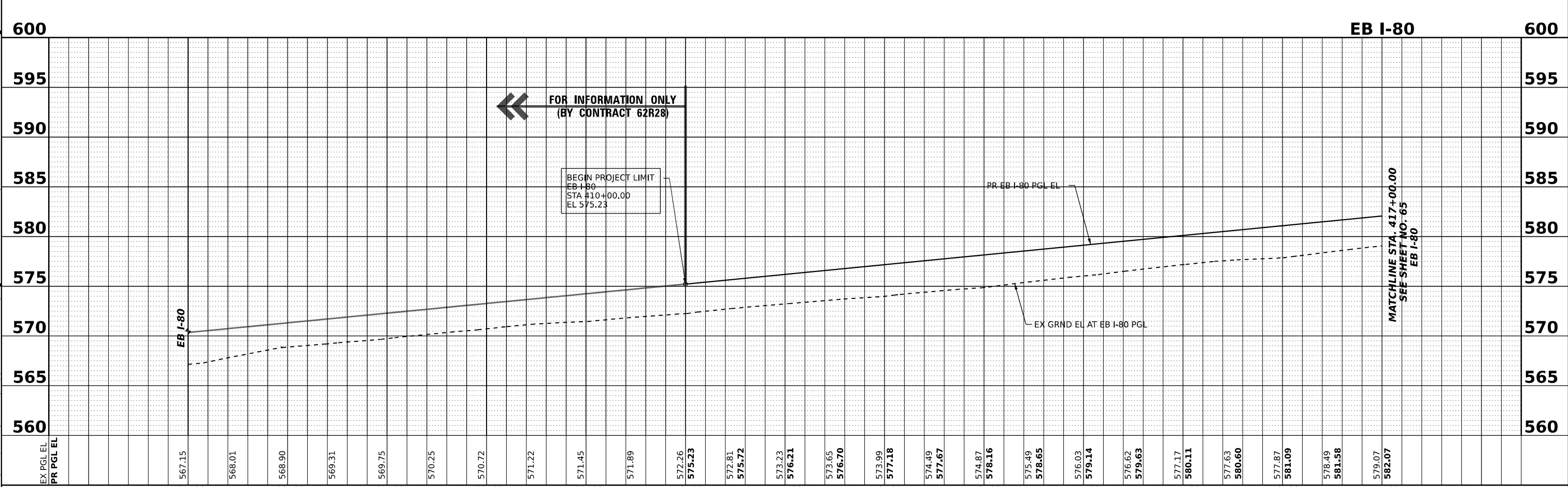
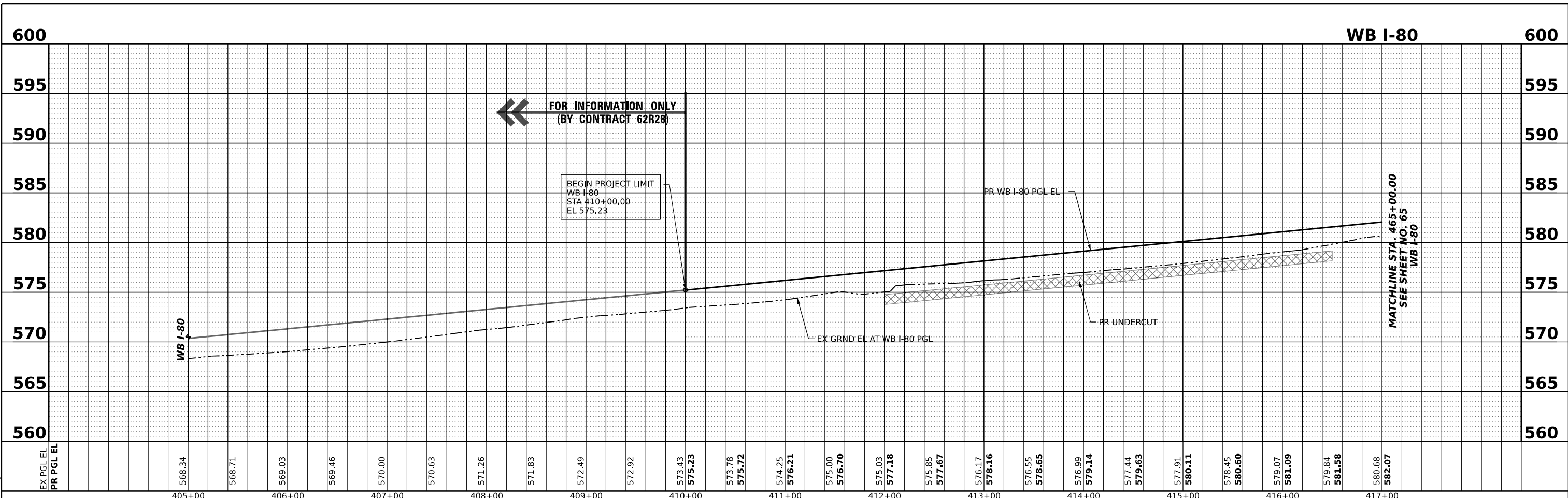

**TRANSYSTEMS**

USER NAME = amkluver	DESIGNED - VJ	REVISED -
PLOT SCALE = 0.16666633 1/ in.	DRAWN - AMK	REVISED -
PLOT DATE = 6/23/2023	CHECKED - JMG	REVISED -
	DATE - 6/26/23	REVISED -

**STATE OF ILLINOIS**  
**DEPARTMENT OF TRANSPORTATION**

**ROADWAY PROFILE**  
**I-80**  
 SCALE: HORIZ: 1"=50'  
 VERT: 1"=5'  
 SHEET 1 OF 12 SHEETS STA. 411+50.00 TO STA. 417+00.00

F.A.I. RTE.	SECTION	COUNTY	TOTAL SHEETS	SHEET NO.
I-80	FAI 80 21 STRUCTURE 6	WILL	898	64
CONTRACT NO. 62R27			ILLINOIS FED. AID PROJECT	

MODEL: PR\_I80\_WB\_WV\_Profile\_2 (Sheet)  
 FILE NAME: P:\projects\trans\2023\62R27\Roadway\Documents\Projects\_2018\C401401\_180022\02-TransSystemsCAD\62R27\Sheets\06-Road\_Plan\_Profile\01E2R27\_RoadProfile\_Sheets.dgn

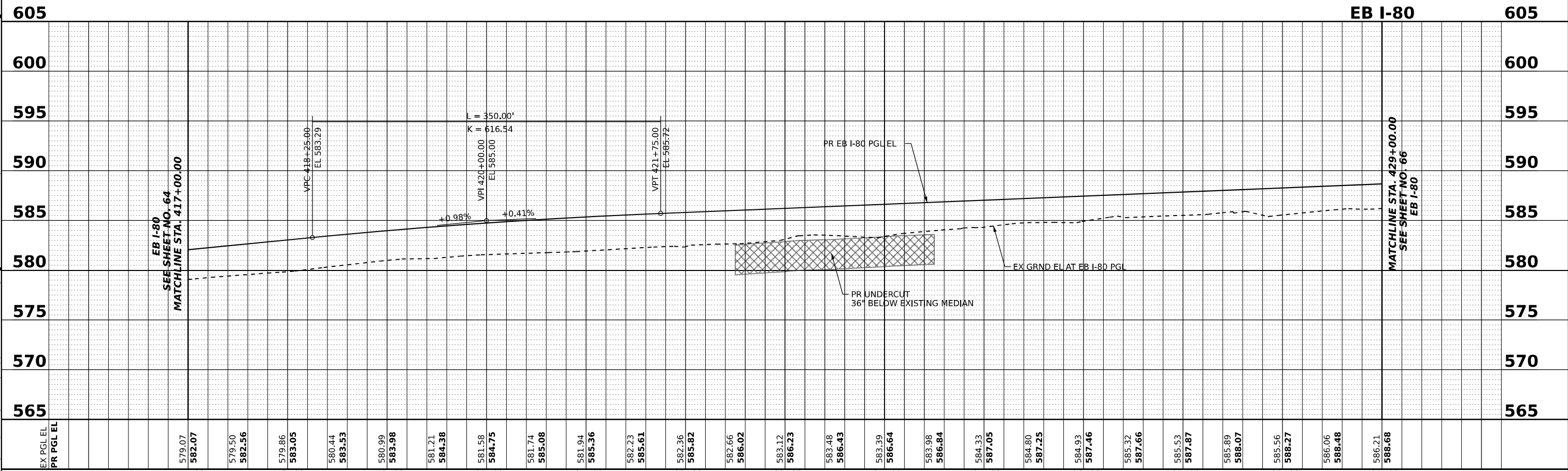
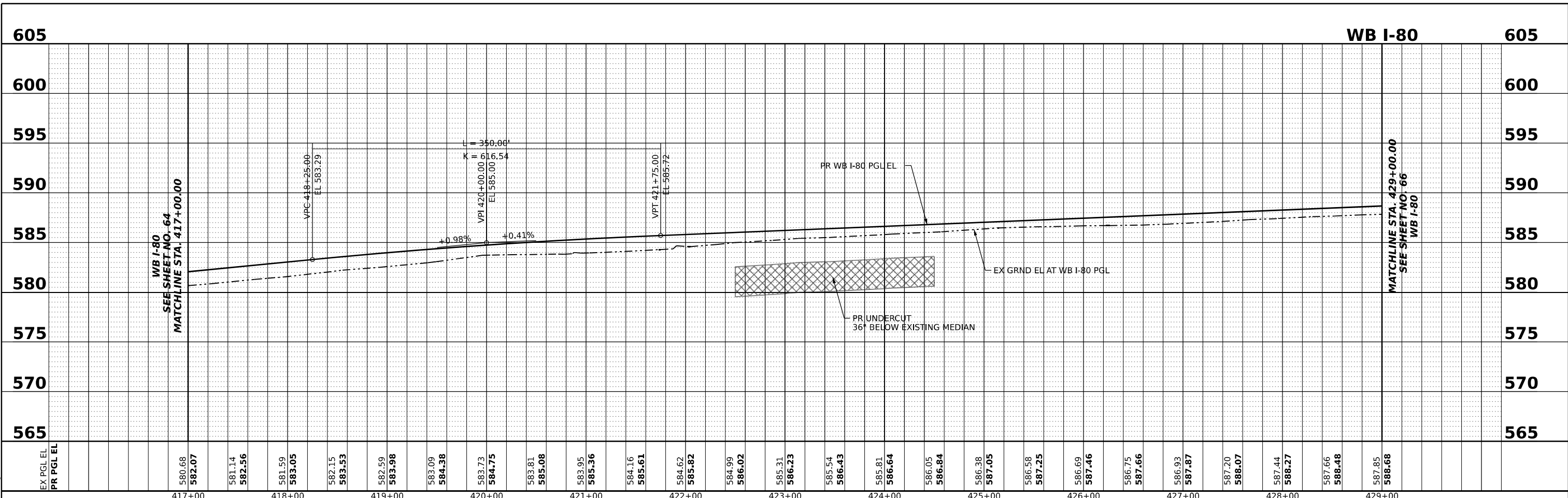

USER NAME = amkluver	DESIGNED - VLJ	REVISED -
PLOT SCALE = 0.16666633 1/ in.	DRAWN - AMK	REVISED -
PLOT DATE = 6/23/2023	CHECKED - JMG	REVISED -
	DATE - 6/26/23	REVISED -

**STATE OF ILLINOIS**  
**DEPARTMENT OF TRANSPORTATION**

**ROADWAY PROFILE**  
**I-80**  
 SCALE: HORIZ: 1"=50'  
 VERT: 1"=5'  
 SHEET 2 OF 12 SHEETS STA. 417+00.00 TO STA. 429+00.00

F.A.I. RTE.	SECTION	COUNTY	TOTAL SHEETS	SHEET NO.
I-80	FAI 80 21 STRUCTURE 6	WILL	898	65
CONTRACT NO. 62R27			ILLINOIS FED. AID PROJECT	

MODEL: PR\_I80\_WB\_WV\_Profile\_3 (Sheet 1)  
 FILE NAME: \\p:\projects\trans\proj\2018\02\2022\02\TransSystems\CAD\2022\Sheets\06-Road\_Plan\_Profile\02I8027\_RoadProfile\_Sheets.dgn

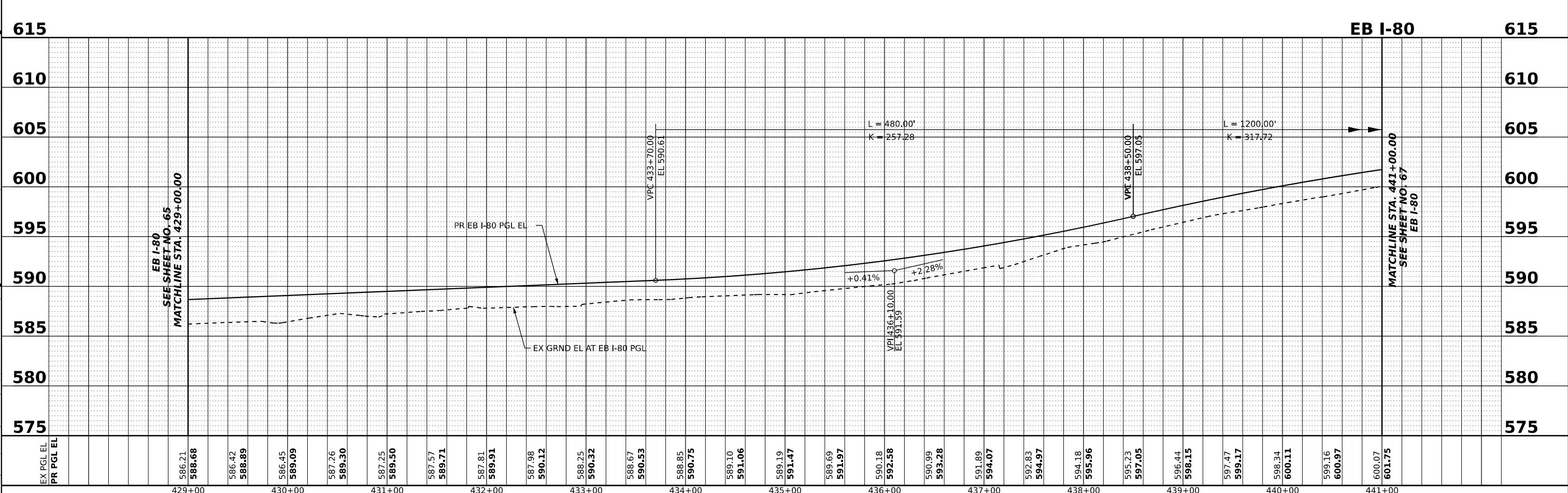
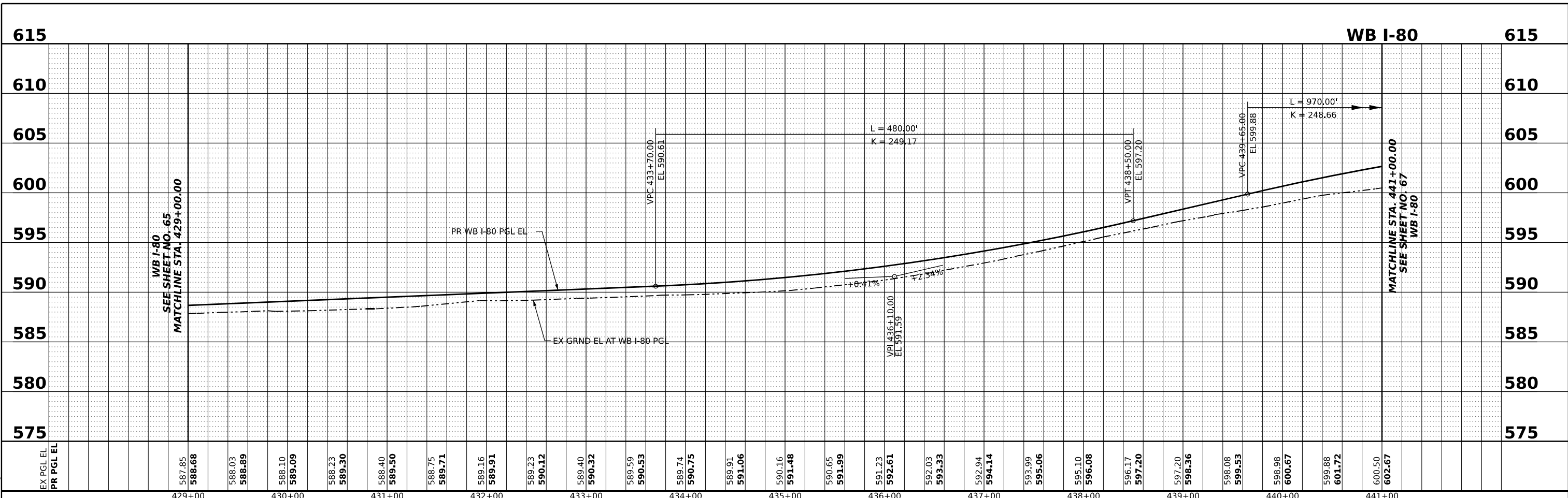

USER NAME = amkluver	DESIGNED - VLJ	REVISED -
PLOT SCALE = 0.16666633 1/ in.	DRAWN - AMK	REVISED -
PLOT DATE = 6/23/2023	CHECKED - JMG	REVISED -
	DATE - 6/26/23	REVISED -

**STATE OF ILLINOIS**  
**DEPARTMENT OF TRANSPORTATION**

<b>ROADWAY PROFILE</b>	
<b>I-80</b>	
SCALE: HORIZ: 1"=50'	SHEET 3 OF 12 SHEETS
VERT: 1"=5'	STA. 429+00.00 TO STA. 441+00.00

F.A.I. R.T.E.	SECTION	COUNTY	TOTAL SHEETS	SHEET NO.
I-80	FAI 80 21 STRUCTURE 6	WILL	898	66
			CONTRACT NO. 62R27	
		ILLINOIS FED. AID PROJECT		

MODEL: PR\_I80\_WB\_WV\_Profile 4 (Sheet 4)  
 FILE NAME: I:\projects\trans\comp\pwr\checked\Documents\Projects\_2018\C4401401\_180022\02-TransSystems\CAD\2327\Sheets\06-Road\_Plan\_Profile\02I80WB\_Profile\_Sheets.dgn

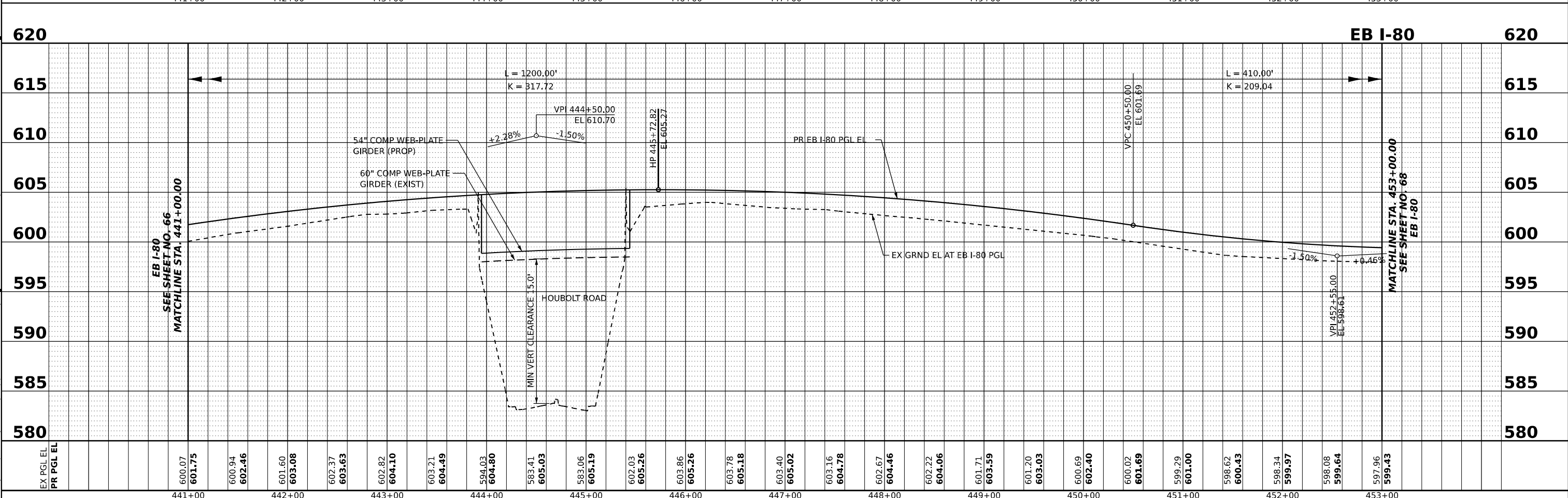
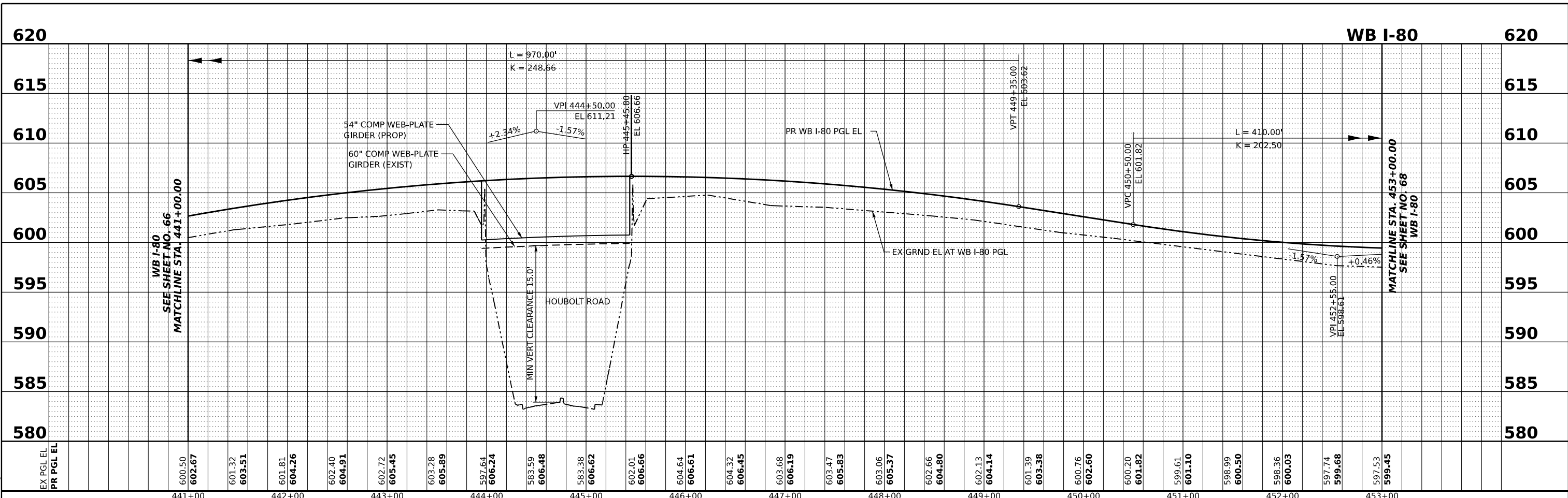

<b>TRANSYSTEMS</b>	USER NAME = amkluver	DESIGNED - VLJ	REVISED -	<b>STATE OF ILLINOIS DEPARTMENT OF TRANSPORTATION</b>	<b>ROADWAY PROFILE I-80</b>			F.A.I. RTE. I-80	SECTION FAI 80 21 STRUCTURE 6	COUNTY WILL	TOTAL SHEETS 898	SHEET NO. 67	
	PLOT SCALE = 0.16666633 1/ in.	CHECKED - JMG	REVISED -		SCALE: HORIZ: 1"=50'	SHEET 4	OF 12 SHEETS	STA. 441+00.00	TO STA. 453+00.00	CONTRACT NO. 62R27			
	PLOT DATE = 6/23/2023	DATE - 6/26/23	REVISED -		ILLINOIS FED. AID PROJECT								

MODEL: PR\_I80\_WB\_WV\_Profile 5 (Sheet 1)  
 FILE NAME: P:\projects\transys\comp\pwr\checked\Documents\Projects\_2018\C401401\_180022\02-TransSystems\CAD\2327\Sheets\06-Road\_Plan\_Profile\012327\_RoadProfile\_Sheets.dgn

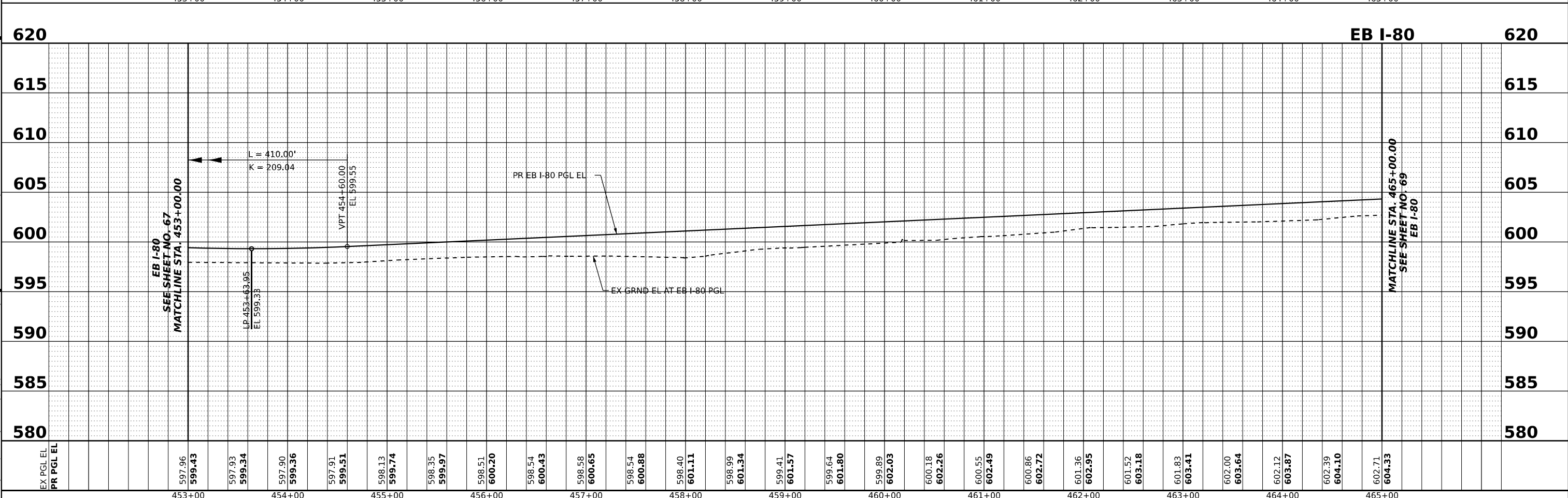
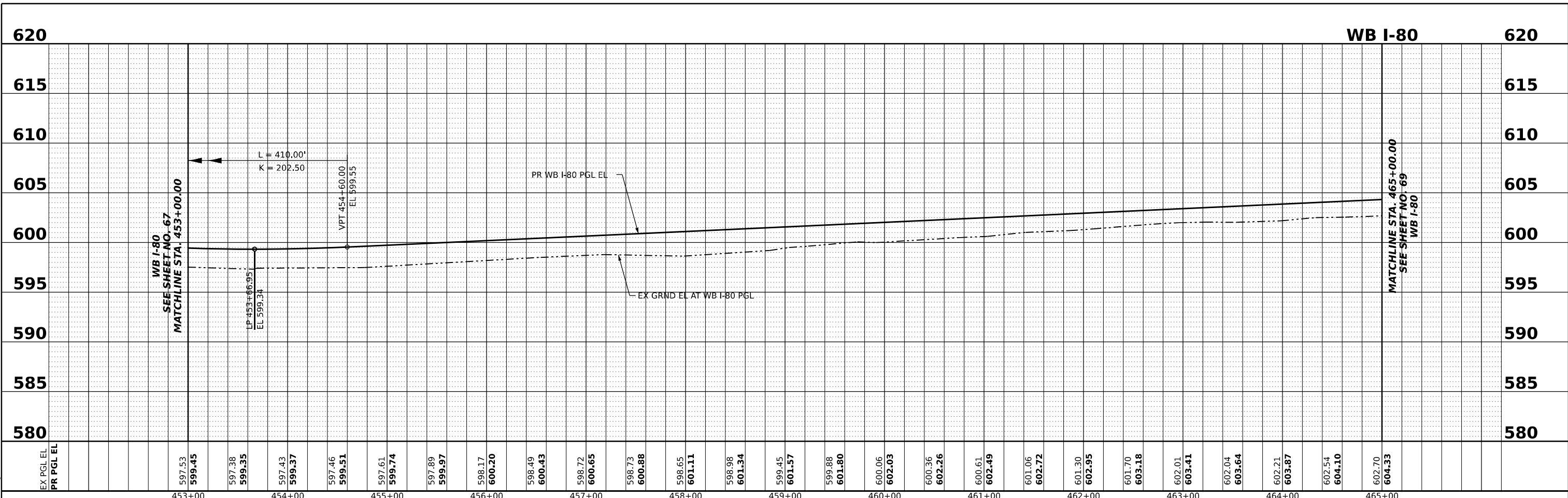

<b>TRANSYSTEMS</b>	USER NAME = amkluver	DESIGNED - VLJ	REVISED -	<b>STATE OF ILLINOIS DEPARTMENT OF TRANSPORTATION</b>	<b>ROADWAY PROFILE I-80</b>			F.A.I. RTE.	SECTION	COUNTY	TOTAL SHEETS	SHEET NO.
	PLOT SCALE = 0.16666633 1/ in.	CHECKED - JMG	REVISED -		I-80	FAI 80 21 STRUCTURE 6	WILL	898	68			
	PLOT DATE = 6/23/2023	DATE - 6/26/23	REVISED -		SCALE: HORIZ: 1"=50' VERT: 1"=5'			SHEET 5 OF 12 SHEETS		STA. 453+00.00 TO STA. 465+00.00	CONTRACT NO. 62R27	

MODEL: PR\_I80\_WB\_WV\_Profile 6 (Sheet)  
 FILE NAME: I:\projects\transys\p22\transys\p22\Road\Documents\Projects\_2018\C4401401\_180022\02-TransSystems\CAD\2227\Sheets\06-Road\Plan\_Profile\02I80WB\_Profile\02I80WB\_Profile.dgn

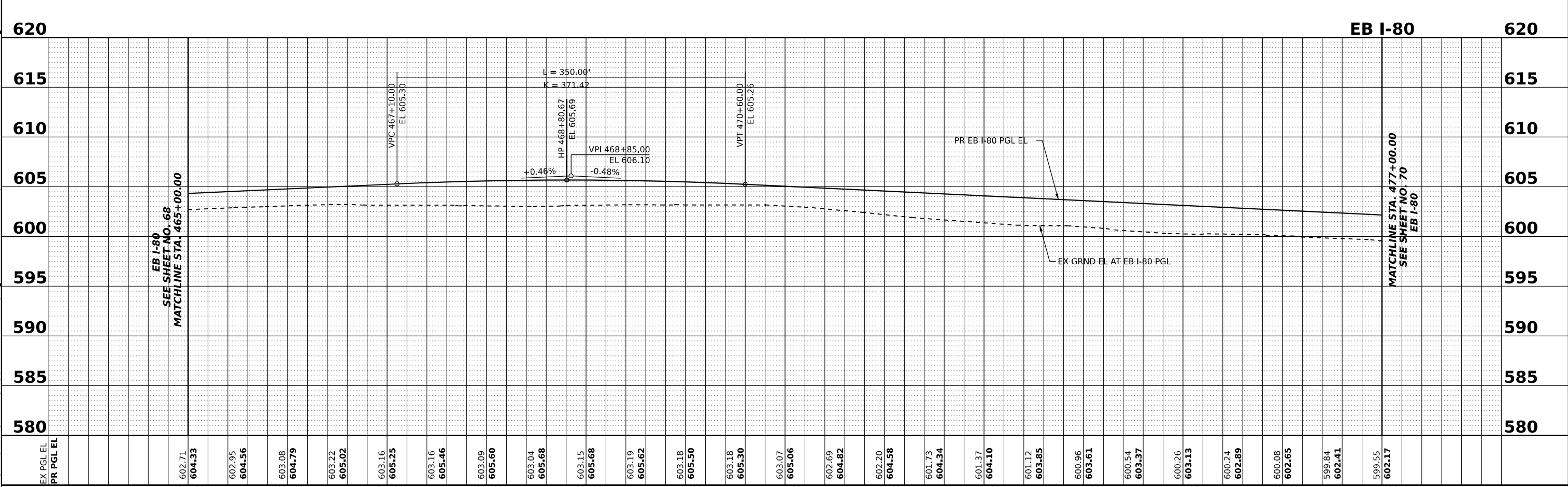
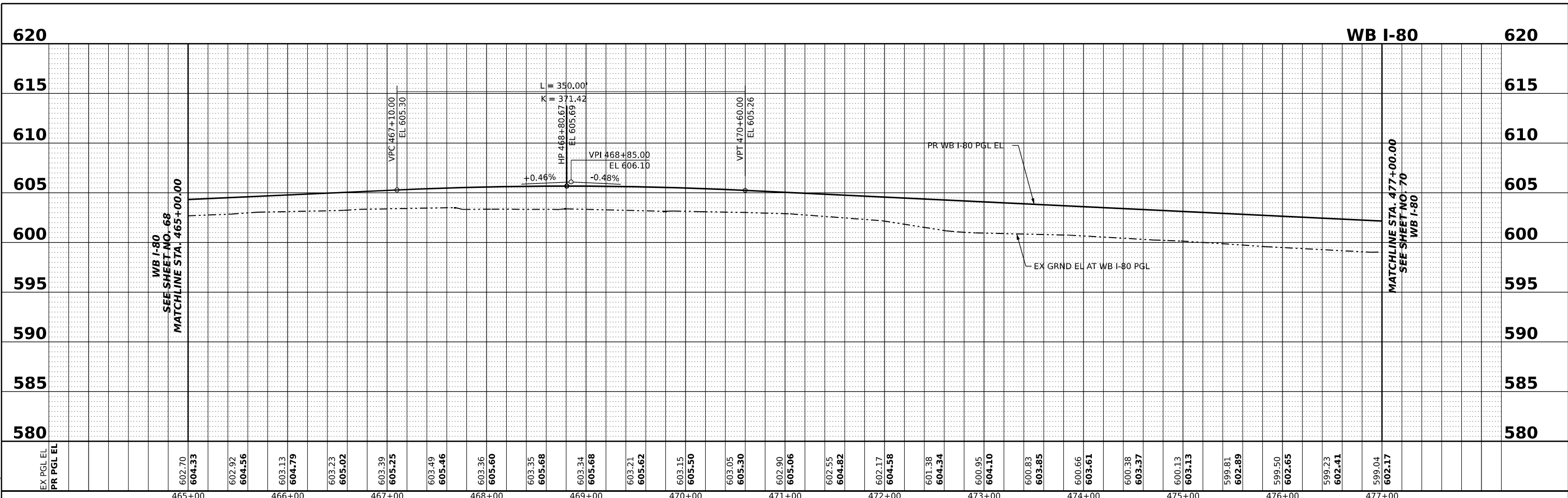

USER NAME = amkluver	DESIGNED - VLJ	REVISED -
PLOT SCALE = 0.16666633 1/ in.	DRAWN - AMK	REVISED -
PLOT DATE = 6/23/2023	CHECKED - JMG	REVISED -
	DATE - 6/26/23	REVISED -

**STATE OF ILLINOIS**  
**DEPARTMENT OF TRANSPORTATION**

**ROADWAY PROFILE**  
**I-80**  
 SCALE: HORIZ: 1"=50'  
 VERT: 1"=5'  
 SHEET 6 OF 12 SHEETS STA. 465+00.00 TO STA. 477+00.00

F.A.I. R.T.E.	SECTION	COUNTY	TOTAL SHEETS	SHEET NO.
I-80	FAI 80 21 STRUCTURE 6	WILL	898	69
CONTRACT NO. 62R27				
ILLINOIS FED. AID PROJECT				

MODEL: PR\_I80\_WB\_WV\_Profile 7 (Sheet)  
FILE NAME: I:\projects\transys\pwr\I80\2022\02-TransSystems\CAD\2022\Sheets\06-Road Plan Profile\012R27\_RlnProfile\_Sheets.dgn

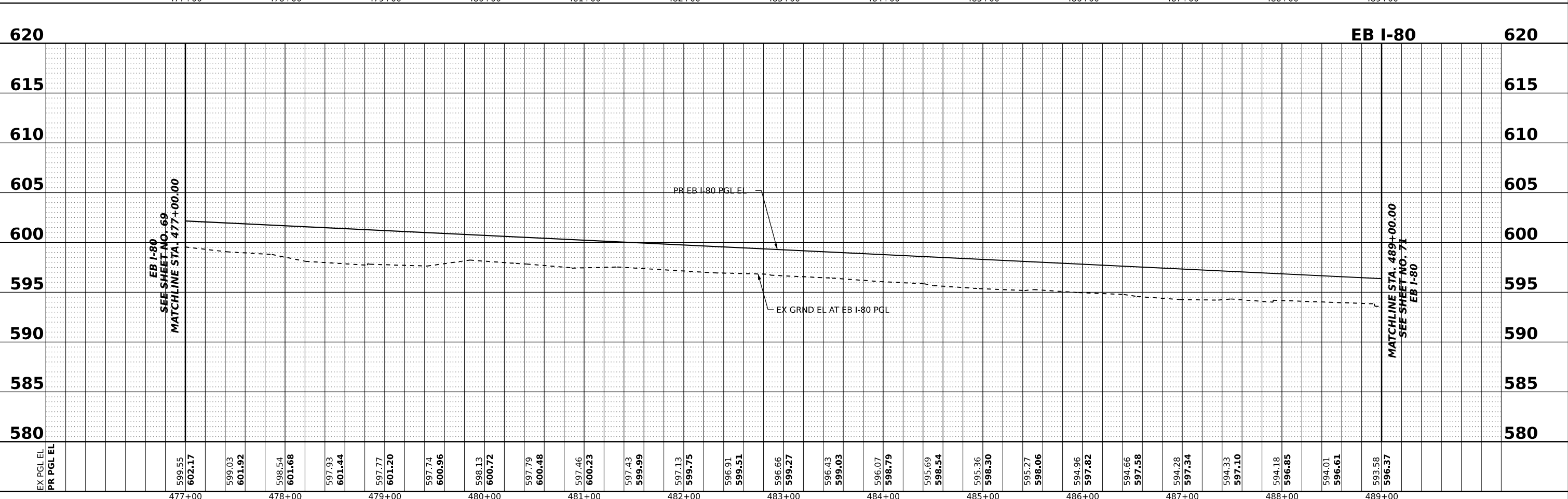
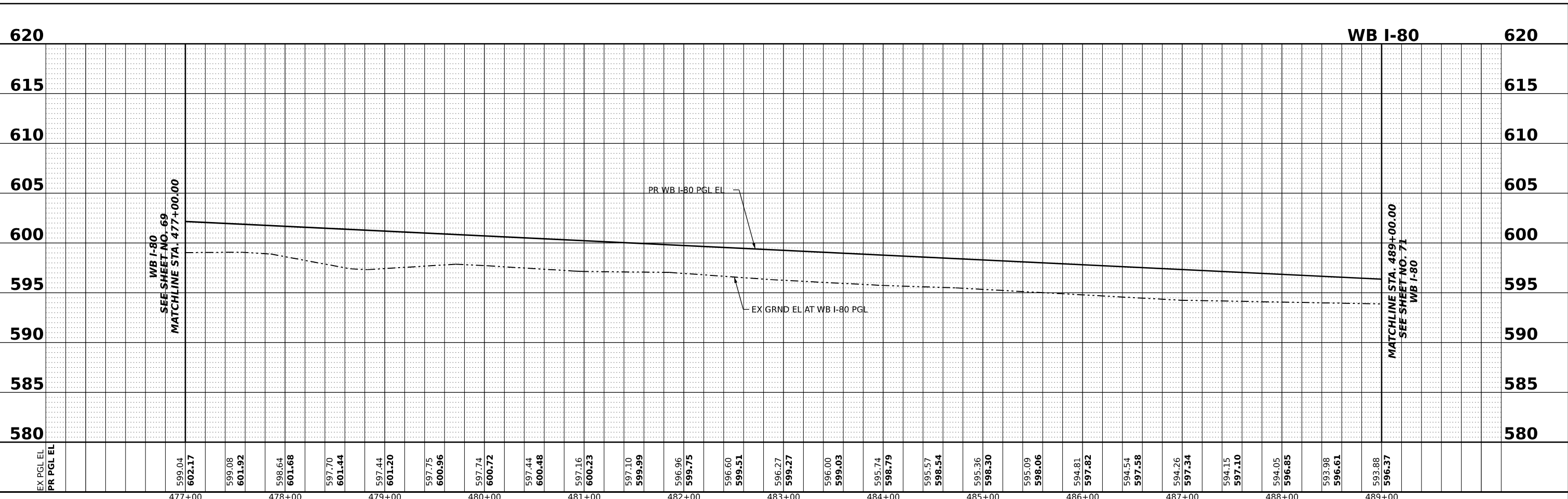

<b>TRANSYSTEMS</b>	USER NAME = amkluver	DESIGNED - VLJ	REVISED -	<b>STATE OF ILLINOIS DEPARTMENT OF TRANSPORTATION</b>	<b>ROADWAY PROFILE</b>			F.A.I. RTE.	SECTION	COUNTY	TOTAL SHEETS	SHEET NO.	
	PLOT SCALE = 0.16666633 1/ in.	CHECKED - JMG	REVISED -		<b>I-80</b>			I-80	FAI 80 21 STRUCTURE 6	WILL	898	70	
	PLOT DATE = 6/23/2023	DATE - 6/26/23	REVISED -		SCALE: HORIZ: 1"=50' VERT: 1"=5'			SHEET 7	OF 12 SHEETS	STA. 477+00.00	TO STA. 489+00.00	CONTRACT NO. 62R27	
											ILLINOIS	FED. AID PROJECT	



MODEL: PR\_I80\_WB\_WV\_Profile 6 (Sheet 8)  
 FILE NAME: \\p01\transys\comp\p01\transys\transys\comp\p01\transys\CAD\62R27\Sheets\06-Road\Plan Profile\012R27\_RoadProfile\_Sheets.dgn

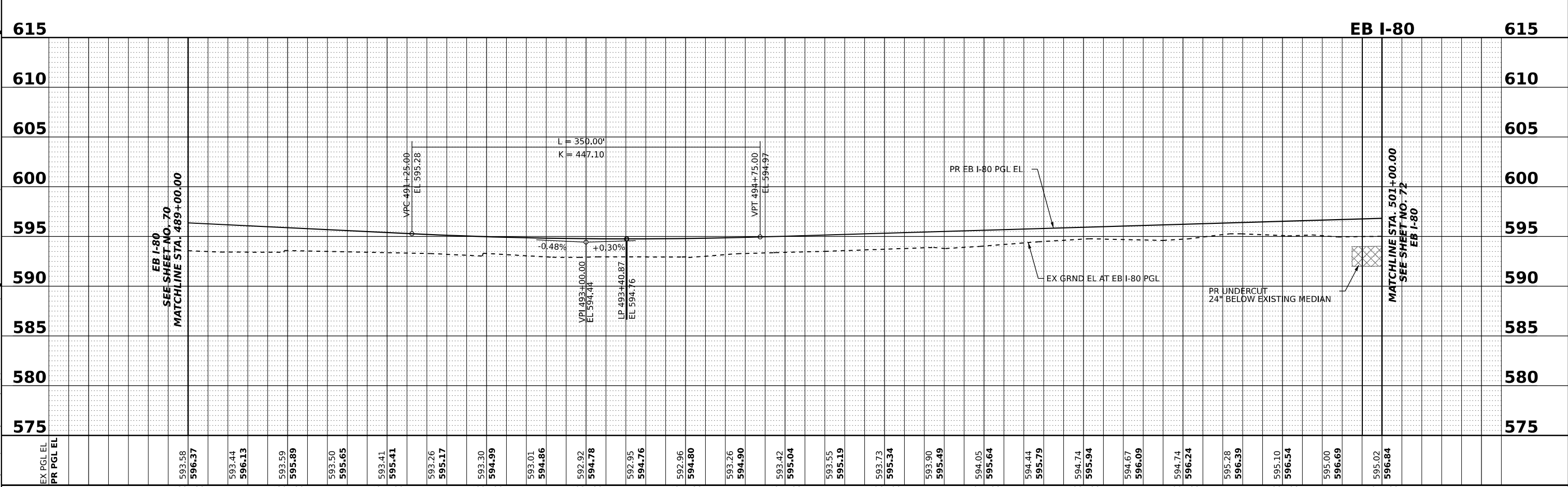
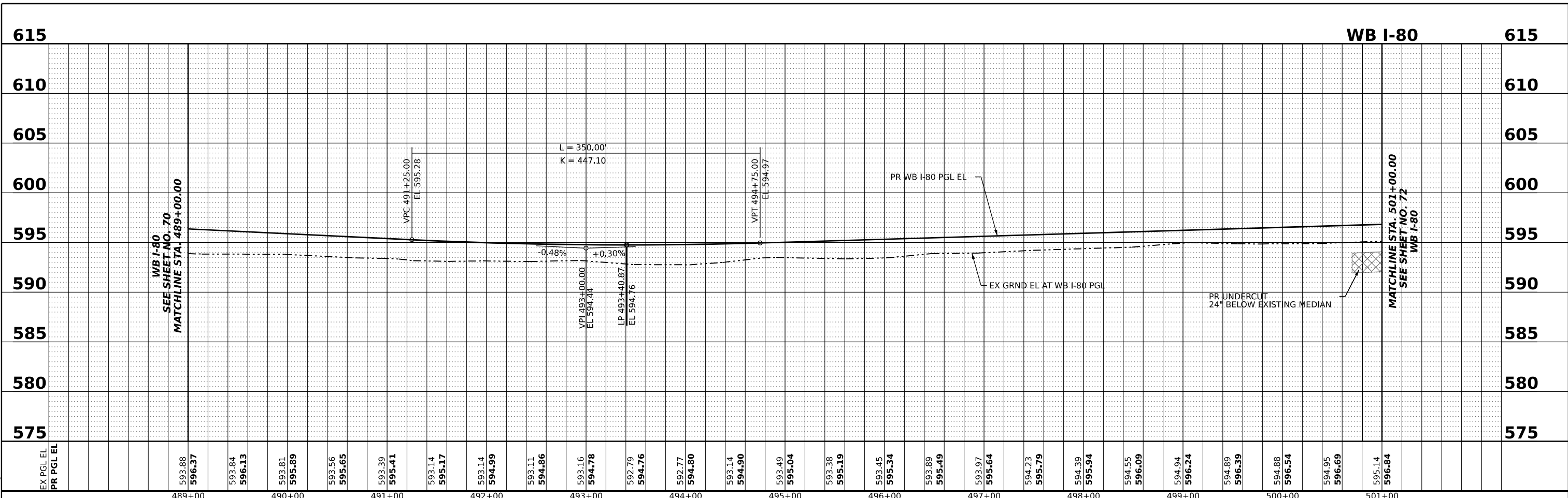

USER NAME = amkluver	DESIGNED - VLJ	REVISED -
PLOT SCALE = 0.16666633 1/ in.	DRAWN - AMK	REVISED -
PLOT DATE = 6/23/2023	CHECKED - JMG	REVISED -
	DATE - 6/26/23	REVISED -

**STATE OF ILLINOIS**  
**DEPARTMENT OF TRANSPORTATION**

**ROADWAY PROFILE**  
**I-80**  
 SCALE: HORIZ: 1"=50'  
 VERT: 1"=5'  
 SHEET 8 OF 12 SHEETS STA. 489+00.00 TO STA. 501+00.00

F.A.I. RTE.	SECTION	COUNTY	TOTAL SHEETS	SHEET NO.
I-80	FAI 80 21 STRUCTURE 6	WILL	898	71
CONTRACT NO. 62R27			ILLINOIS FED. AID PROJECT	

MODEL: PR\_I80\_WB\_WV\_Profile\_9 (Sheet)  
 FILE NAME: \\p:\projects\transys\comp\p\1\road\Documents\Projects\_2018\C401401\_180022\02-TransSystems\CAD\2327\Sheets\06-Road\_Plan\_Profile\02327\_RoadProfile\_Sheets.dgn

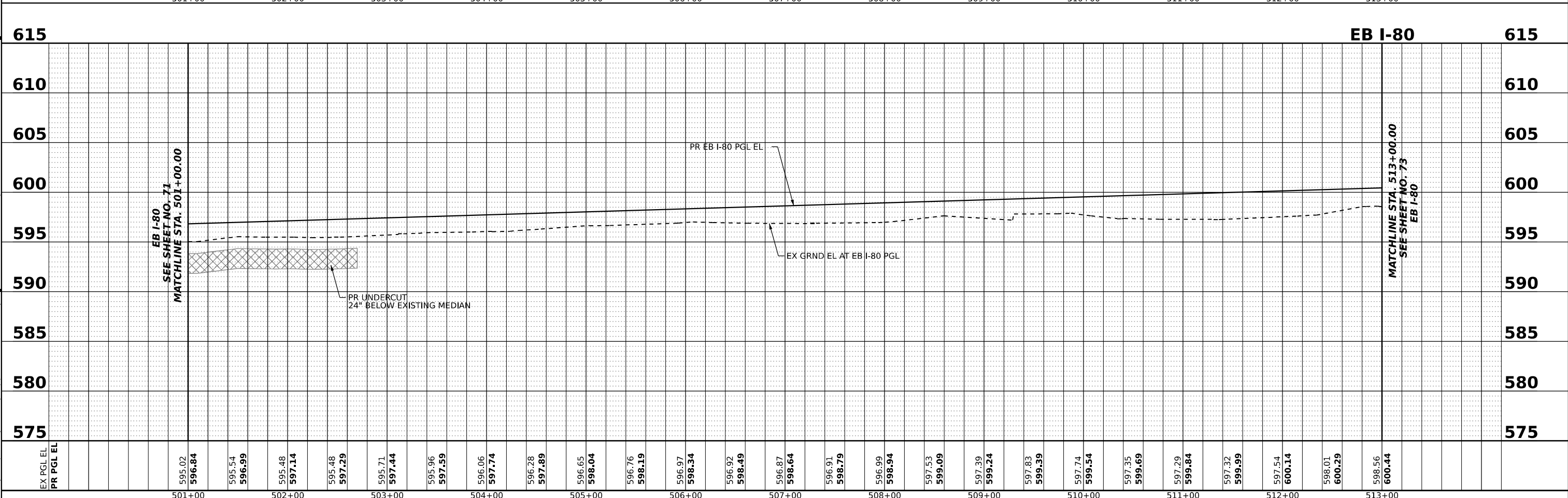
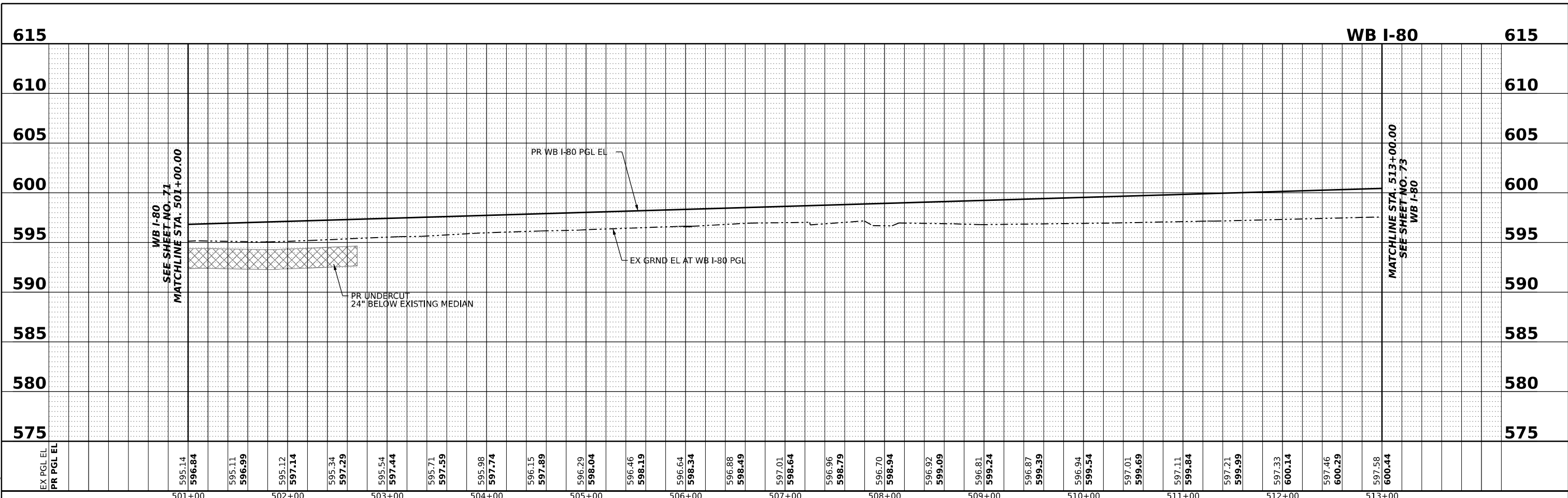

USER NAME = amkluver	DESIGNED - VLJ	REVISED -
PLOT SCALE = 0.16666633 1/ in.	DRAWN - AMK	REVISED -
PLOT DATE = 6/23/2023	CHECKED - JMG	REVISED -
	DATE - 6/26/23	REVISED -

**STATE OF ILLINOIS**  
**DEPARTMENT OF TRANSPORTATION**

SCALE: HORIZ: 1"=50'		SHEET 9	OF 12	SHEETS	STA. 501+00.00	TO STA. 513+00.00
VERT: 1"=5'						

**ROADWAY PROFILE**  
**I-80**

F.A.I. RTE.	SECTION	COUNTY	TOTAL SHEETS	SHEET NO.
I-80	FAI 80 21 STRUCTURE 6	WILL	898	72
CONTRACT NO. 62R27				
ILLINOIS   FED. AID PROJECT				

MODEL: PR\_I80\_WB\_WV\_Profile 10 (Sheet)  
 FILE NAME: P:\GIS\Systems\p1222022\TransSystems\p1222022\Road\Profile\062227\Sheets\062227\Road\Profile\062227\_RoadProfile\_Sheets.dgn

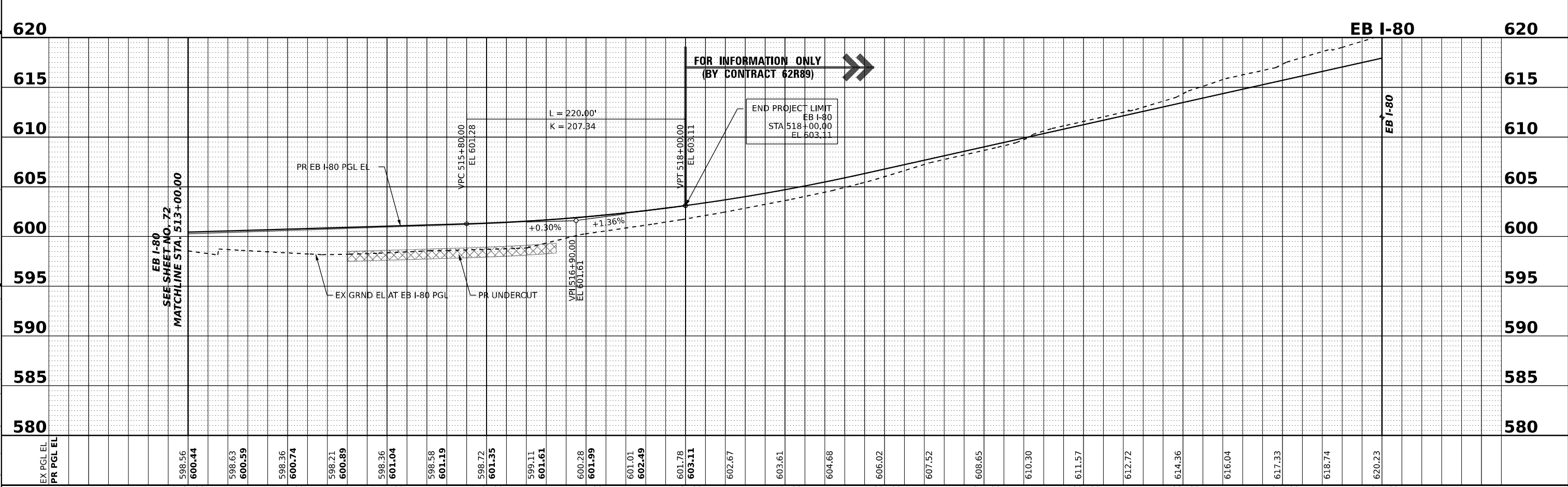
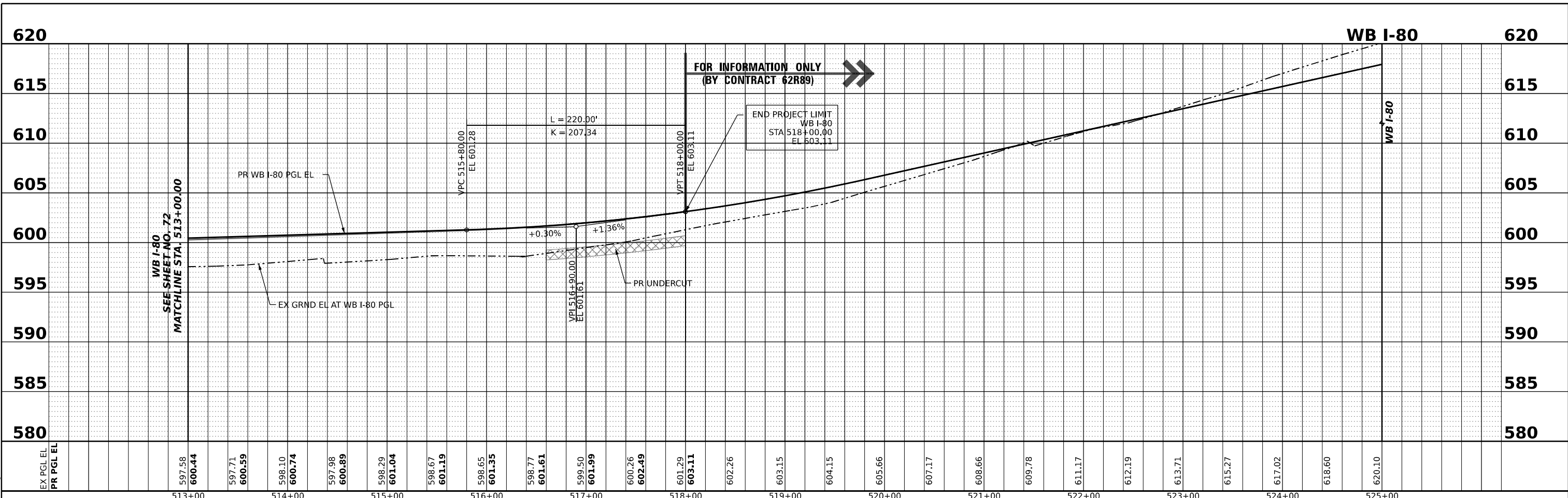

**TRANSYSTEMS**

USER NAME = amkluver	DESIGNED - VLJ	REVISED -
PLOT SCALE = 0.16666633 1/ in.	DRAWN - AMK	REVISED -
PLOT DATE = 6/23/2023	CHECKED - JMG	REVISED -
	DATE - 6/26/23	REVISED -

**STATE OF ILLINOIS**  
**DEPARTMENT OF TRANSPORTATION**

**ROADWAY PROFILE**  
**I-80**  
 SCALE: HORIZ: 1"=50'  
 VERT: 1"=5'  
 SHEET 10 OF 12 SHEETS STA. 513+00.00 TO STA. 518+00.00

F.A.I. RTE.	SECTION	COUNTY	TOTAL SHEETS	SHEET NO.
I-80	FAI 80 21 STRUCTURE 6	WILL	898	73
CONTRACT NO. 62R27				
ILLINOIS FED. AID PROJECT				

MODEL: BL\_HOBT\_A - Profile 1 (Sheet 1)  
 FILE NAME: P:\GIS\Projects\Roadway\Roadway\Documents\Projects\_2018\C401401\_180022\02-TransSystems\CAD\2022\Sheets\06-Road\_Plan\_Profile\022827\_Houbolt\_Profile\_Sheets.dgn

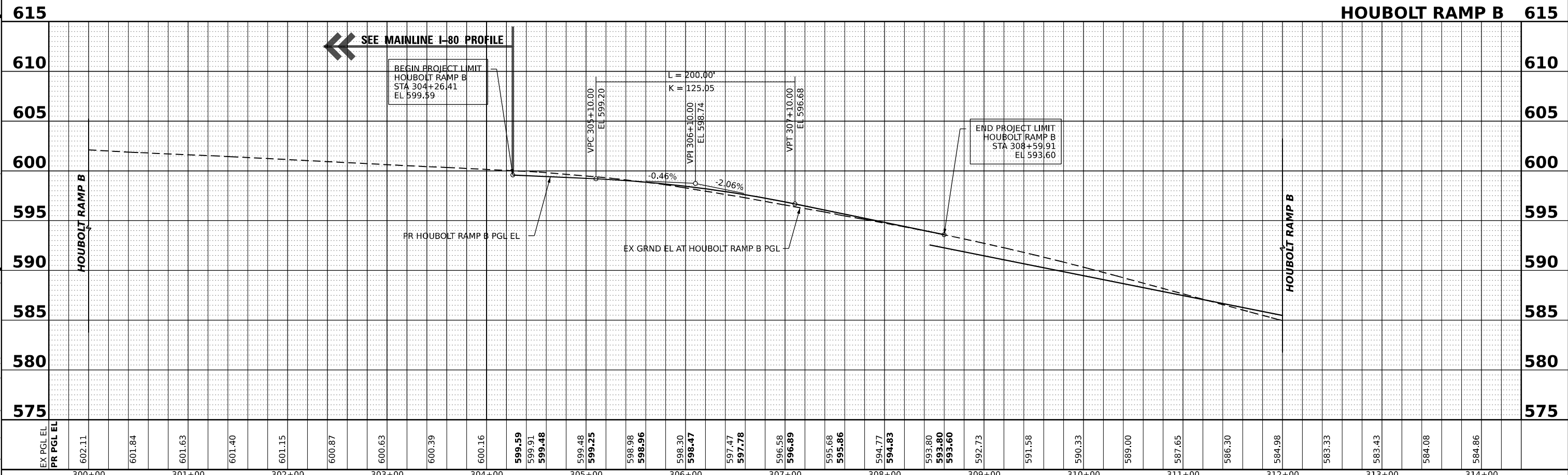
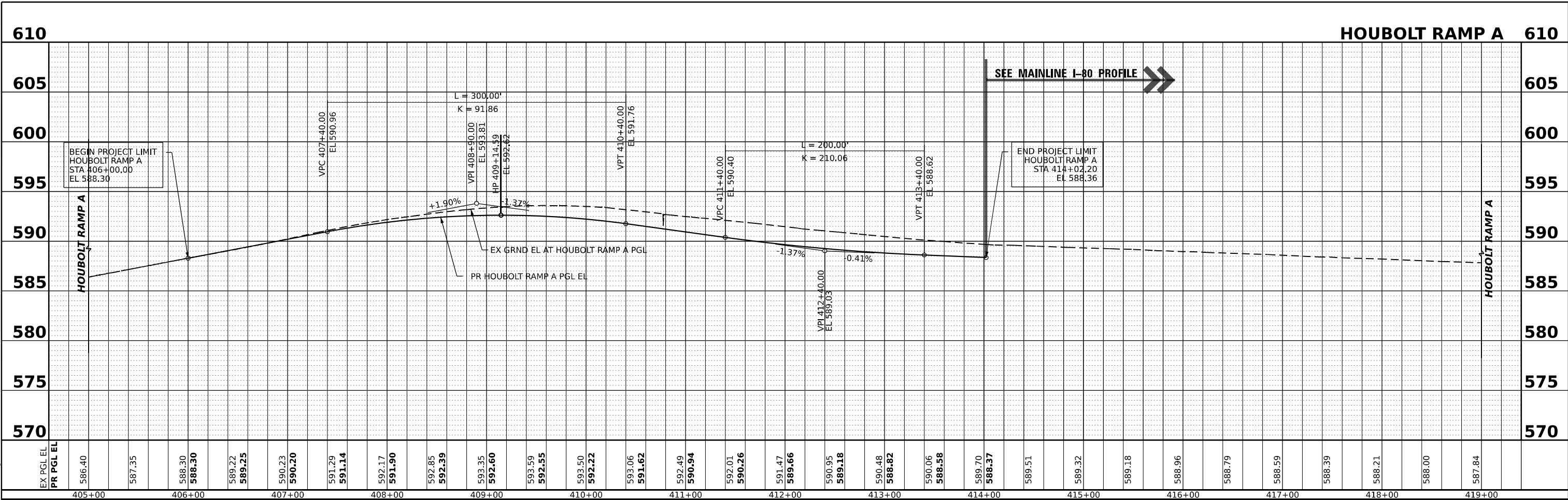

**TRANSYSTEMS**

USER NAME = amkluver	DESIGNED - VLJ	REVISED -
PLOT SCALE = 0.16666633 1/ in.	DRAWN - AMK	REVISED -
PLOT DATE = 6/23/2023	CHECKED - JMG	REVISED -
	DATE - 6/26/23	REVISED -

**STATE OF ILLINOIS  
DEPARTMENT OF TRANSPORTATION**

<b>ROADWAY PROFILE</b>		
<b>Houbolt Ramp A &amp; Ramp B</b>		
SCALE: 1"=50'	SHEET 11 OF 12 SHEETS	STA. TO STA.

F.A.I. RTE.	SECTION	COUNTY	TOTAL SHEETS	SHEET NO.
I-80	FAI 80 21 STRUCTURE 6	WILL	898	74
CONTRACT NO. 62R27			ILLINOIS FED. AID PROJECT	

MODEL: BL\_HOBT\_C\_Profile 1 (Sheet 1)  
 FILE NAME: P:\GIS\Projects\2018\CH401\01\180022\02-TransSystems\CAD\62R27\Sheets\06-Road Plan Profile\02\2827\_Houbolt\_Profile\_Sheets.dgn

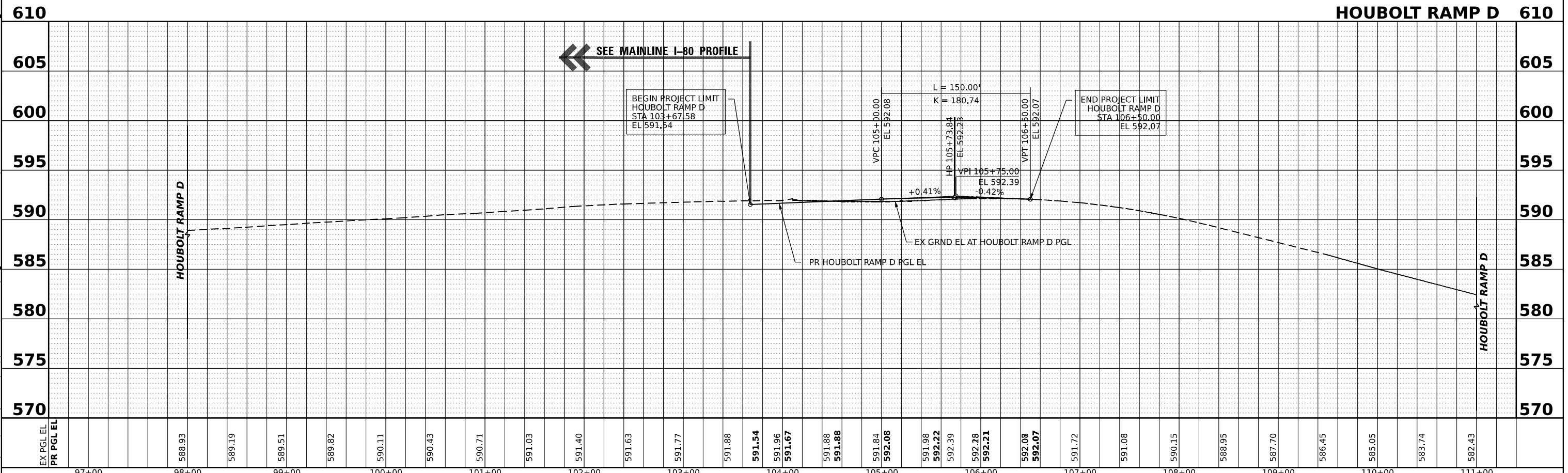
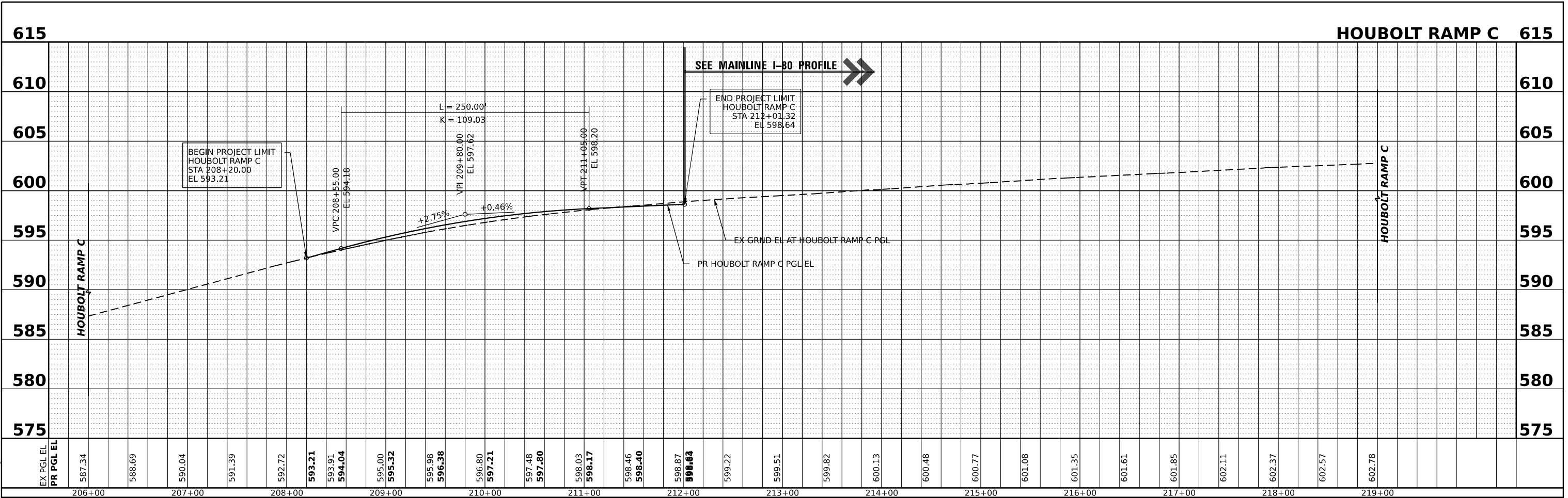

**TRANSYSTEMS**

USER NAME	= amkluver	DESIGNED	- VLJ	REVISED	-
PLOT SCALE	= 0.16666633 1/ in.	DRAWN	- AMK	REVISED	-
PLOT DATE	= 6/23/2023	CHECKED	- JMG	REVISED	-
		DATE	- 6/26/23	REVISED	-

**STATE OF ILLINOIS  
DEPARTMENT OF TRANSPORTATION**

SCALE: 1"=50'		ROADWAY PROFILE	
		HOUBOLT RAMP C & RAMP D	
SHEET 12	OF 12 SHEETS	STA.	TO STA.

F.A.I. RTE.	SECTION	COUNTY	TOTAL SHEETS	SHEET NO.
I-80	FAI 80 21 STRUCTURE 6	WILL	898	75
CONTRACT NO. 62R27				
ILLINOIS		FED. AID PROJECT		

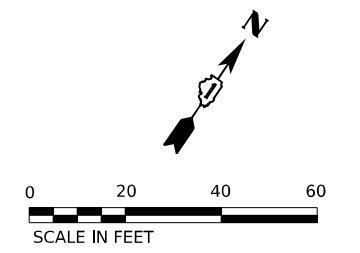
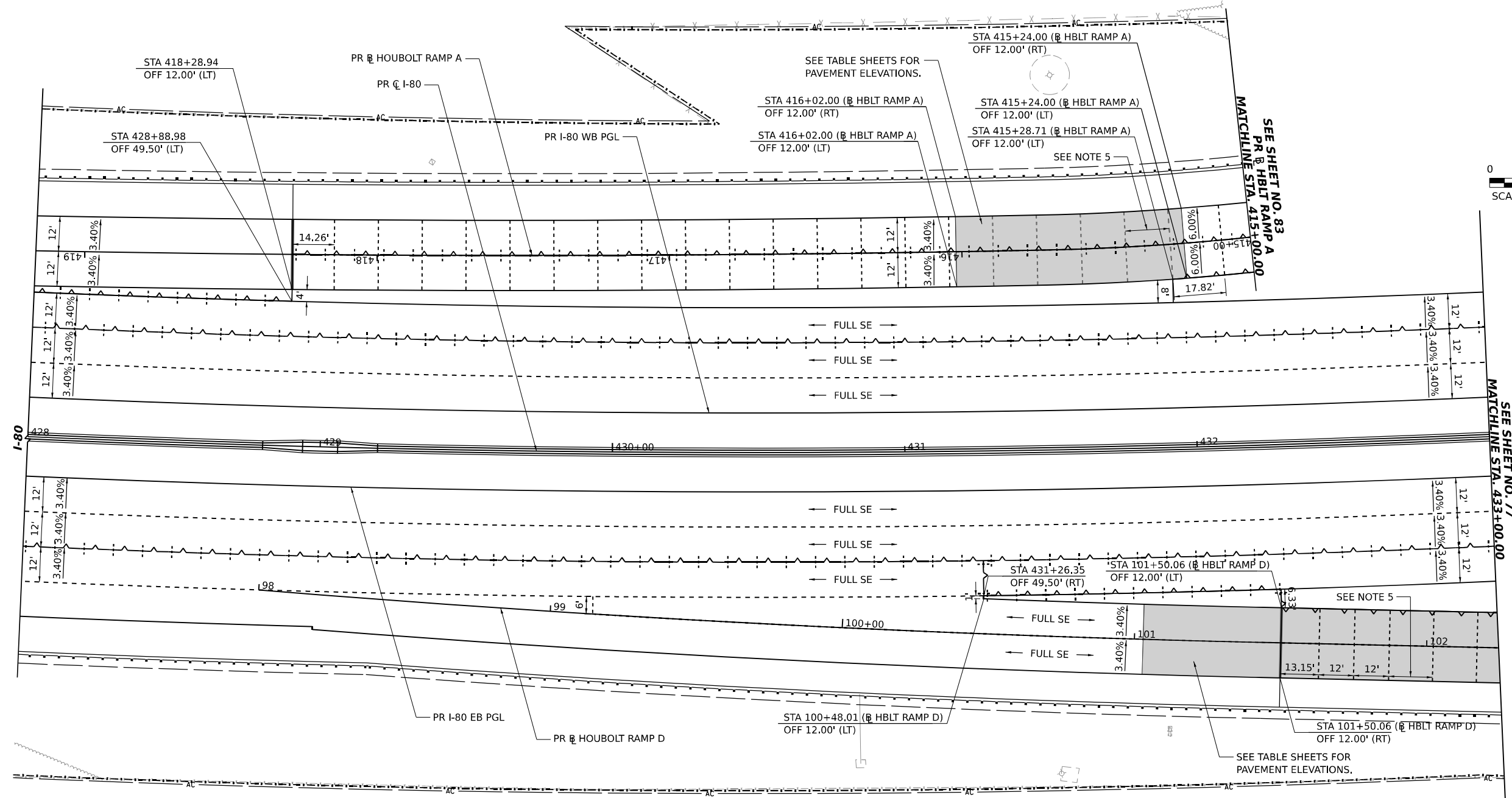

SEE SHEET NO. 83  
PR @ HOBLT RAMP A  
MATCHLINE STA. 415+00.00

SEE SHEET NO. 77  
MATCHLINE STA. 433+00.00

**LEGEND**

- +---+ CONSTRUCTION JOINT
  - LONGITUDINAL CONSTRUCTION JOINT
    - 1. NO. 6 X 2'-6" LONG DEFORMED TIE BARS (EPOXY COATED) FORMED IN PLACE OR MECHANICALLY INSERTED AT 3' C-C (STANDARD 420001-10) OR
    - 2. NO. 6 X 2' LONG DEFORMED TIE BARS (EPOXY COATED) GROUTED IN PLACE AT 3' C-C (STANDARD 420001-10)
  - TRANSVERSE CONSTRUCTION JOINT
    - 1'-6" LONG DOWEL BARS (EPOXY COATED) AT 1' C-C (STANDARD 420101-07)
- SAWED JOINT (MAINLINE)
  - LONGITUDINAL SAWED JOINT
    - NO. 6 X 2'-6" LONG DEFORMED TIE BARS (EPOXY COATED) AT 3' C-C (STANDARD 420001-10)
  - TRANSVERSE CONTRACTION JOINT
    - 1'-6" LONG DOWEL BARS, 1 1/2" DIAMETER (EPOXY COATED) AT 1' C-C (STANDARD 420001-10)
- SAWED JOINT (RAMPS)
  - LONGITUDINAL SAWED JOINT
    - NO. 6 X 3' LONG DEFORMED TIE BARS AT 1'-6" C-C (DISTRICT STANDARD BD-49)
  - TRANSVERSE CONTRACTION JOINT
    - 1'-6" LONG DOWEL BARS, 1 1/2" DIAMETER (EPOXY COATED) AT 1' C-C (DISTRICT STANDARD BD-49)
- EXPANSION JOINT
  - 1'-6" LONG DOWEL BARS, 1 1/2" DIAMETER (EPOXY COATED) AT 1' C-C (STANDARD 420001-10)
- KEYED JOINT
  - LONGITUDINAL KEYED JOINT WITHOUT TIE BARS
- +---+ CONSTRUCTION JOINT AT CROWN
  - LONGITUDINAL CONSTRUCTION JOINT
    - 1. NO. 6 X 2' LONG DOWEL BARS (EPOXY COATED) FORMED IN PLACE OR MECHANICALLY INSERTED AT 3'-C-C (SEE SHEET 53) OR
    - 2. NO. 6 X 2' LONG DOWEL BARS (EPOXY COATED) GROUTED IN PLACE AT 3' C-C (SEE SHEET 53)

PAVEMENT CROSS SLOPE TRANSITIONS

**NOTES:**

1. UNLESS NOTED OTHERWISE, ALL STATIONS AND OFFSETS ARE TAKEN FROM PR CL I-80.
2. FOR PAVEMENT, SHOULDER, AND BARRIER MATERIALS SEE ROADWAY PLANS 54 TO 63.
3. SEE SUPERELEVATION TABLE FOR SHOULDER SLOPES.
4. ADDITIONAL SAWED TRANSVERSE CONTRACTION JOINTS MAY BE REQUIRED IN THE FIELD, AS DIRECTED BY THE ENGINEER. EXACT LOCATIONS TO BE VERIFIED IN THE FIELD AND APPROVED BY THE ENGINEER.
5. ALL TRANSVERSE JOINTS SHALL BE 15.0 FEET TYPICAL AND MAXIMUM 18.0 FEET UNLESS OTHERWISE NOTED. SEE STANDARD 420101-07 FOR ADDITIONAL INFORMATION, REGARDING TRANSVERSE JOINT SPACING REQUIREMENTS.
6. SEE STANDARD 420001-10 FOR INFORMATION REGARDING SEALING REQUIREMENTS FOR TRANSVERSE EXPANSION JOINTS.
7. PAVEMENT ROUNDOUTS FOR MANHOLES AND VALVE VAULTS SHALL BE CONSTRUCTED IN ACCORDANCE WITH STANDARD 420111-04.
8. ALL ELEVATIONS NOT SHOWN SHALL FOLLOW THE TYPICAL SECTIONS AND PROFILES.
9. SEE STANDARD 420206-13 FOR ENTRANCE RAMP TERMINAL JOINTING INFORMATION AND 420306-11 FOR EXIT RAMP TERMINAL JOINTING INFORMATION.
10. ALL TRANSVERSE JOINTS ON RAMPS SHALL BE A MAXIMUM OF 12.0 FEET UNLESS OTHERWISE NOTED. SEE DISTRICT DETAIL BD-49 FOR ADDITIONAL INFORMATION, REGARDING TRANSVERSE JOINT SPACING REQUIREMENTS.

MODEL: BL\_IP\_00\_W\_Plan 5 (Sheet) FILE NAME: P:\projects\2023\20230627\transystems\pwr\checked\Documents\Projects\_2018\CI-401\401180022\02-Transystems\CAD\2023\20230627\20230627-SHT-01\TNTING.dwg



USER NAME = amkluver	DESIGNED - VLJ	REVISED -
PLOT SCALE = 0.16666633 1/ in.	DRAWN - AMK	REVISED -
PLOT DATE = 6/23/2023	CHECKED - JMG	REVISED -
	DATE - 6/26/23	REVISED -

**STATE OF ILLINOIS  
DEPARTMENT OF TRANSPORTATION**

**JOINTING AND SUPERELEVATION PLAN**  
**I-80**

SCALE: 1"=20'    SHEET 1 OF 10 SHEETS    STA.    TO STA.

F.A.I. RTE.	SECTION	COUNTY	TOTAL SHEETS	SHEET NO.
I-80	FAI 80 21 STRUCTURE 6	WILL	898	76
CONTRACT NO. 62R27				
ILLINOIS   FED. AID PROJECT				

**LEGEND**

- +---+ CONSTRUCTION JOINT
  - LONGITUDINAL CONSTRUCTION JOINT
    - 1. NO. 6 X 2'-6" LONG DEFORMED TIE BARS (EPOXY COATED) FORMED IN PLACE OR MECHANICALLY INSERTED AT 3' C-C (STANDARD 420001-10) OR
    - 2. NO. 6 X 2' LONG DEFORMED TIE BARS (EPOXY COATED) GROUTED IN PLACE AT 3' C-C (STANDARD 420001-10)
  - TRANSVERSE CONSTRUCTION JOINT
    - 1'-6" LONG DOWEL BARS (EPOXY COATED) AT 1' C-C (STANDARD 420101-07)
- SAWED JOINT (MAINLINE)
  - LONGITUDINAL SAWED JOINT
    - NO. 6 X 2'-6" LONG DEFORMED TIE BARS (EPOXY COATED) AT 3' C-C (STANDARD 420001-10)
  - TRANSVERSE CONTRACTION JOINT
    - 1'-6" LONG DOWEL BARS, 1½" DIAMETER (EPOXY COATED) AT 1' C-C (STANDARD 420001-10)
- SAWED JOINT (RAMP)
  - LONGITUDINAL SAWED JOINT
    - NO. 6 X 3' LONG DEFORMED TIE BARS AT 1'-6" C-C (DISTRICT STANDARD BD-49)
  - TRANSVERSE CONTRACTION JOINT
    - 1'-6" LONG DOWEL BARS, 1½" DIAMETER (EPOXY COATED) AT 1' C-C (DISTRICT STANDARD BD-49)
- EXPANSION JOINT
  - 1'-6" LONG DOWEL BARS, 1½" DIAMETER (EPOXY COATED) AT 1' C-C (STANDARD 420001-10)
- KEYED JOINT
  - LONGITUDINAL KEYED JOINT WITHOUT TIE BARS
- +---+ CONSTRUCTION JOINT AT CROWN
  - LONGITUDINAL CONSTRUCTION JOINT
    - 1. NO. 6 X 2' LONG DOWEL BARS (EPOXY COATED) FORMED IN PLACE OR MECHANICALLY INSERTED AT 3'-C-C (SEE SHEET53) OR
    - 2. NO. 6 X 2' LONG DOWEL BARS (EPOXY COATED) GROUTED IN PLACE AT 3' C-C (SEE SHEET53)
- PAVEMENT CROSS SLOPE TRANSITIONS

**NOTES:**

1. UNLESS NOTED OTHERWISE, ALL STATIONS AND OFFSETS ARE TAKEN FROM PR CL I-80.
2. FOR PAVEMENT, SHOULDER, AND BARRIER MATERIALS SEE ROADWAY PLANS 54 TO 63.
3. SEE SUPERELEVATION TABLE FOR SHOULDER SLOPES.
4. ADDITIONAL SAWED TRANSVERSE CONTRACTION JOINTS MAY BE REQUIRED IN THE FIELD, AS DIRECTED BY THE ENGINEER, EXACT LOCATIONS TO BE VERIFIED IN THE FIELD AND APPROVED BY THE ENGINEER.
5. ALL TRANSVERSE JOINTS SHALL BE A MAXIMUM OF 15.0 FEET UNLESS OTHERWISE NOTED. SEE STANDARD 420101-07 FOR ADDITIONAL INFORMATION, REGARDING TRANSVERSE JOINT SPACING REQUIREMENTS.
6. SEE STANDARD 420001-10 FOR INFORMATION REGARDING SEALING REQUIREMENTS FOR TRANSVERSE EXPANSION JOINTS.
7. PAVEMENT ROUNDOUTS FOR MANHOLES AND VALVE VAULTS SHALL BE CONSTRUCTED IN ACCORDANCE WITH STANDARD 420111-04.
8. ALL ELEVATIONS NOT SHOWN SHALL FOLLOW THE TYPICAL SECTIONS AND PROFILES.
9. SEE STANDARD 420206-13 FOR ENTRANCE RAMP TERMINAL JOINTING INFORMATION AND 420306-11 FOR EXIT RAMP TERMINAL JOINTING INFORMATION.
10. ALL TRANSVERSE JOINTS ON RAMPS SHALL BE A MAXIMUM OF 12.0 FEET UNLESS OTHERWISE NOTED. SEE DISTRICT DETAIL BD-49 FOR ADDITIONAL INFORMATION, REGARDING TRANSVERSE JOINT SPACING REQUIREMENTS.

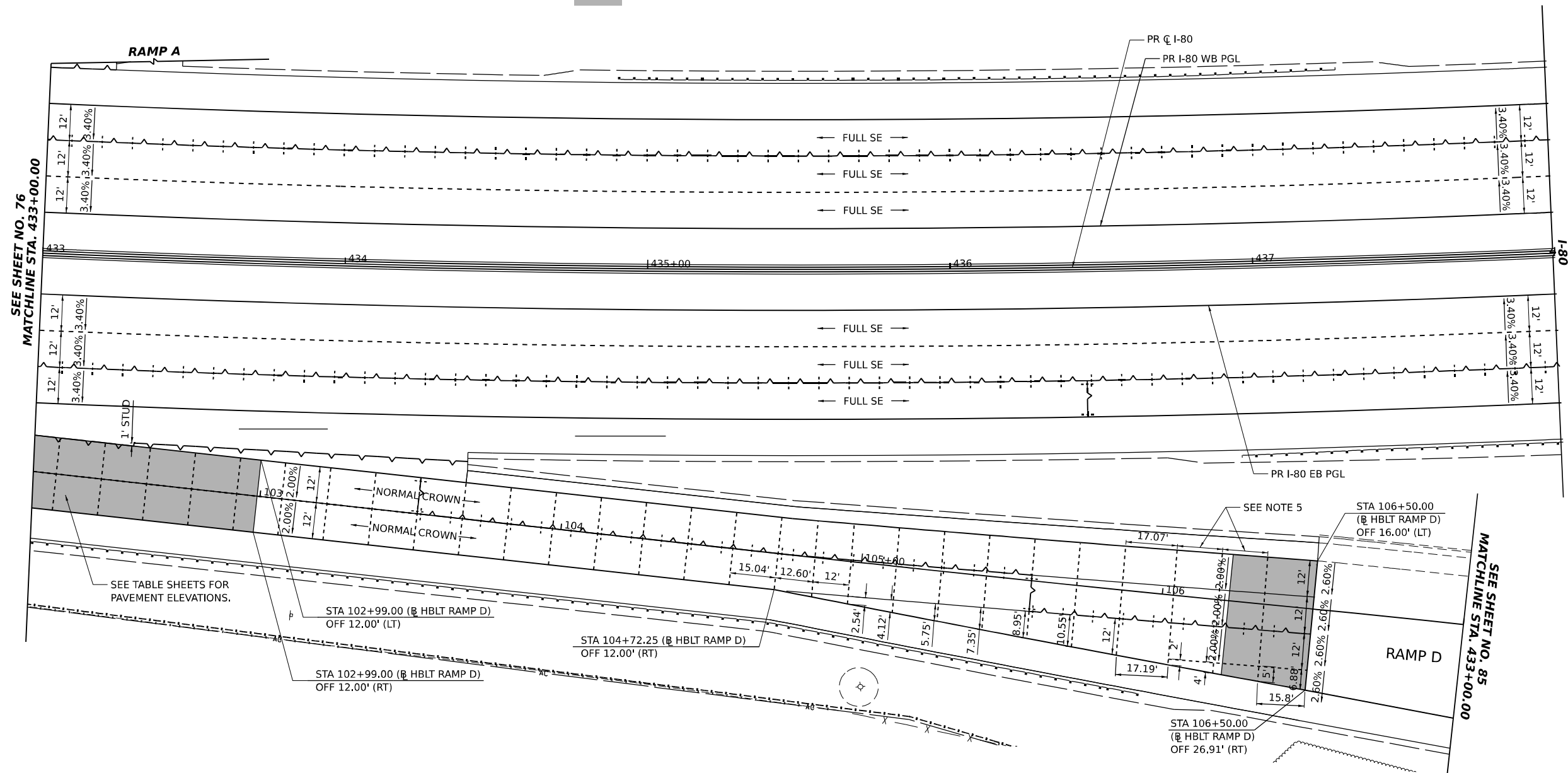
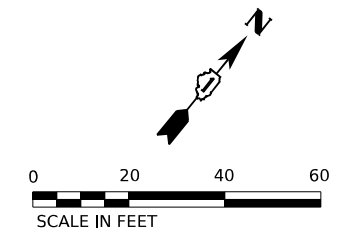

SEE SHEET NO. 76  
MATCHLINE STA. 433+00.00

SEE SHEET NO. 85  
MATCHLINE STA. 433+00.00



USER NAME = amkluver	DESIGNED - VLJ	REVISED -
PLOT SCALE = 0.16666633 1/ in.	DRAWN - AMK	REVISED -
PLOT DATE = 6/23/2023	CHECKED - JMG	REVISED -
	DATE - 6/26/23	REVISED -

**STATE OF ILLINOIS  
DEPARTMENT OF TRANSPORTATION**

<b>JOINTING AND SUPERELEVATION PLAN</b>			
<b>I-80</b>			
SCALE: 1"=20'	SHEET 2	OF 10 SHEETS	STA. TO STA.

F.A.I. RTE.	SECTION	COUNTY	TOTAL SHEETS	SHEET NO.
I-80	FAI 80 21 STRUCTURE 6	WILL	898	77
CONTRACT NO. 62R27				
ILLINOIS FED. AID PROJECT				

MODEL: BL\_PR\_80\_W\_Plan C (Sheet)  
 FILE NAME: P:\Projects\2022\62R27\Structure6\Drawings\CAD\62R27\Structure6\08-Cure and Super\0162R27-SHT-0101.DWG.dgn

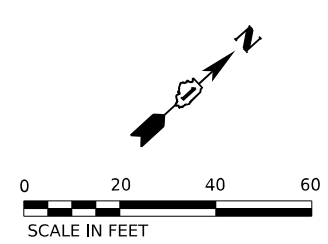
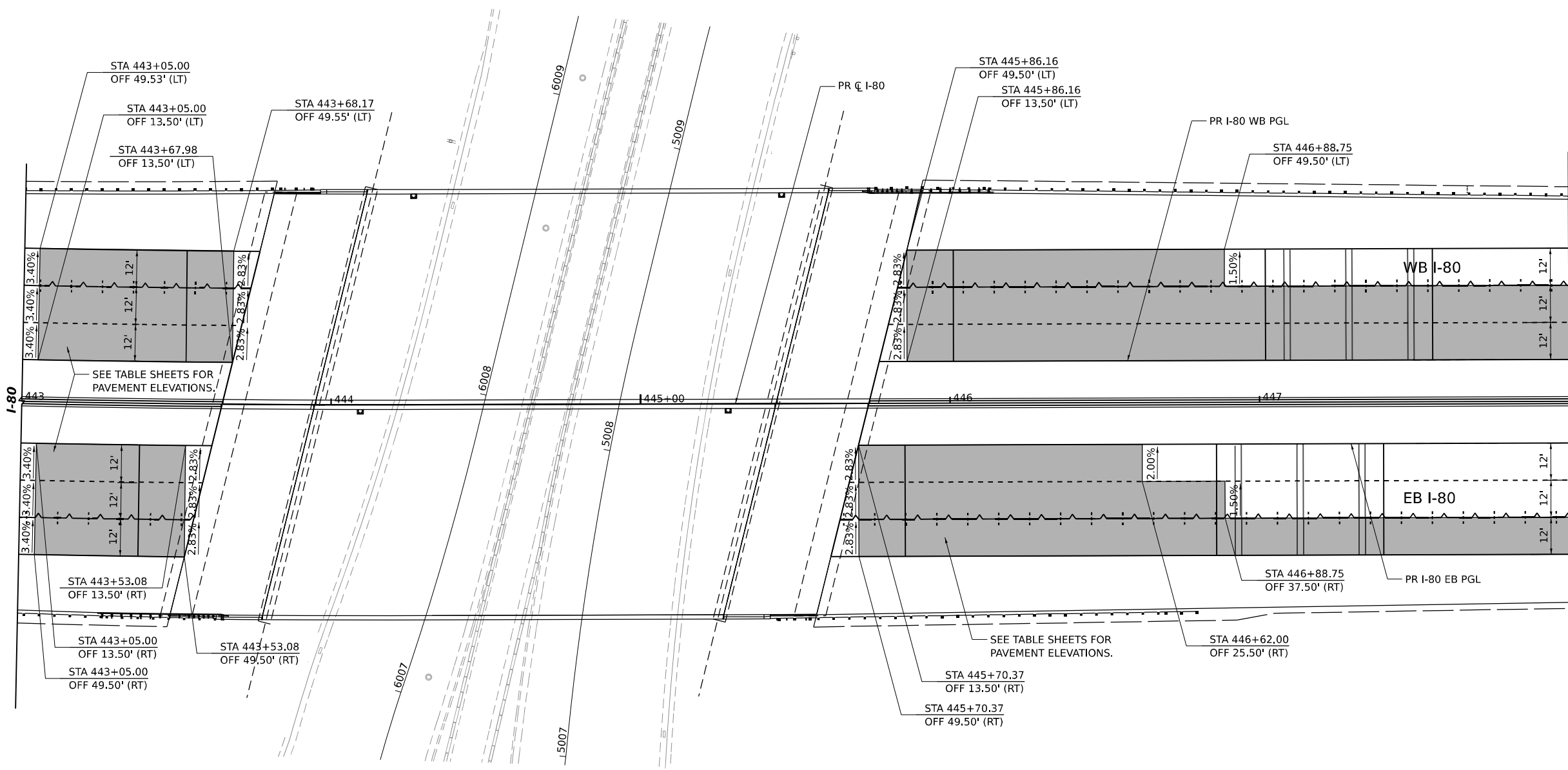

SEE SHEET NO. 79  
MATCHLINE STA. 448+00.00

**LEGEND**

- +---+ CONSTRUCTION JOINT
  - LONGITUDINAL CONSTRUCTION JOINT
    1. NO. 6 X 2'-6" LONG DEFORMED TIE BARS (EPOXY COATED) FORMED IN PLACE OR MECHANICALLY INSERTED AT 3' C-C (STANDARD 420001-10) OR
    2. NO. 6 X 2' LONG DEFORMED TIE BARS (EPOXY COATED) GROUTED IN PLACE AT 3' C-C (STANDARD 420001-10)
  - TRANSVERSE CONSTRUCTION JOINT
    - 1'-6" LONG DOWEL BARS (EPOXY COATED) AT 1' C-C (STANDARD 420101-07)
- SAWED JOINT (MAINLINE)
  - LONGITUDINAL SAWED JOINT
    - NO. 6 X 2'-6" LONG DEFORMED TIE BARS (EPOXY COATED) AT 3' C-C (STANDARD 420001-10)
  - TRANSVERSE CONTRACTION JOINT
    - 1'-6" LONG DOWEL BARS, 1 1/2" DIAMETER (EPOXY COATED) AT 1' C-C (STANDARD 420001-10)
- SAWED JOINT (RAMPS)
  - LONGITUDINAL SAWED JOINT
    - NO. 6 X 3' LONG DEFORMED TIE BARS AT 1'-6" C-C (DISTRICT STANDARD BD-49)
  - TRANSVERSE CONTRACTION JOINT
    - 1'-6" LONG DOWEL BARS, 1 1/2" DIAMETER (EPOXY COATED) AT 1' C-C (DISTRICT STANDARD BD-49)
- EXPANSION JOINT
  - 1'-6" LONG DOWEL BARS, 1 1/2" DIAMETER (EPOXY COATED) AT 1' C-C (STANDARD 420001-10)
- KEYED JOINT
  - LONGITUDINAL KEYED JOINT WITHOUT TIE BARS
- +---+ CONSTRUCTION JOINT AT CROWN
  - LONGITUDINAL CONSTRUCTION JOINT
    1. NO. 6 X 2' LONG DOWEL BARS (EPOXY COATED) FORMED IN PLACE OR MECHANICALLY INSERTED AT 3'-C-C (SEE SHEET 53) OR
    2. NO. 6 X 2' LONG DOWEL BARS (EPOXY COATED) GROUTED IN PLACE AT 3' C-C (SEE SHEET 53)

PAVEMENT CROSS SLOPE TRANSITIONS

**NOTES:**

1. UNLESS NOTED OTHERWISE, ALL STATIONS AND OFFSETS ARE TAKEN FROM PR CL I-80.
2. FOR PAVEMENT, SHOULDER, AND BARRIER MATERIALS SEE ROADWAY PLANS 54 TO 63.
3. SEE SUPERELEVATION TABLE FOR SHOULDER SLOPES.
4. ADDITIONAL SAWED TRANSVERSE CONTRACTION JOINTS MAY BE REQUIRED IN THE FIELD, AS DIRECTED BY THE ENGINEER. EXACT LOCATIONS TO BE VERIFIED IN THE FIELD AND APPROVED BY THE ENGINEER.
5. ALL TRANSVERSE JOINTS SHALL BE 15.0 FEET TYPICAL AND MAXIMUM 18.0 FEET UNLESS OTHERWISE NOTED. SEE STANDARD 420101-07 FOR ADDITIONAL INFORMATION, REGARDING TRANSVERSE JOINT SPACING REQUIREMENTS.
6. SEE STANDARD 420001-10 FOR INFORMATION REGARDING SEALING REQUIREMENTS FOR TRANSVERSE EXPANSION JOINTS.
7. PAVEMENT ROUNDOUTS FOR MANHOLES AND VALVE VAULTS SHALL BE CONSTRUCTED IN ACCORDANCE WITH STANDARD 420111-04.
8. ALL ELEVATIONS NOT SHOWN SHALL FOLLOW THE TYPICAL SECTIONS AND PROFILES.
9. SEE STANDARD 420206-13 FOR ENTRANCE RAMP TERMINAL JOINTING INFORMATION AND 420306-11 FOR EXIT RAMP TERMINAL JOINTING INFORMATION.
10. ALL TRANSVERSE JOINTS ON RAMPS SHALL BE A MAXIMUM OF 12.0 FEET UNLESS OTHERWISE NOTED. SEE DISTRICT DETAIL BD-49 FOR ADDITIONAL INFORMATION, REGARDING TRANSVERSE JOINT SPACING REQUIREMENTS.

MODEL: BL\_IP\_00\_W\_Plan 8 (Sheet) FILE NAME: P:\transys\comp\pwr\hosed\Documents\Projects\_2013\CI-401\401180022\02-TransSystems\CAD\62R27\Sheets\08-Cover and Super\052R27-SHTJOINTING.dgn



USER NAME	= amkluver
PLOT SCALE	= 0.16666633 1/ in.
PLOT DATE	= 6/23/2023

DESIGNED	- VLJ
DRAWN	- AMK
CHECKED	- JMG
DATE	- 6/26/23

REVISED	-
REVISED	-
REVISED	-
REVISED	-

**STATE OF ILLINOIS  
DEPARTMENT OF TRANSPORTATION**

**JOINTING AND SUPERELEVATION PLAN  
I-80**

SCALE: 1"=20' SHEET 3 OF 10 SHEETS STA. TO STA.

F.A.I. RTE.	SECTION	COUNTY	TOTAL SHEETS	SHEET NO.
I-80	FAI 80 21 STRUCTURE 6	WILL	898	78
CONTRACT NO. 62R27				
ILLINOIS FED. AID PROJECT				



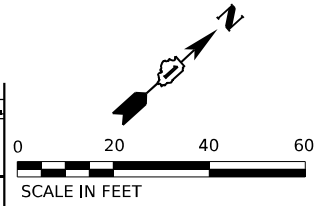
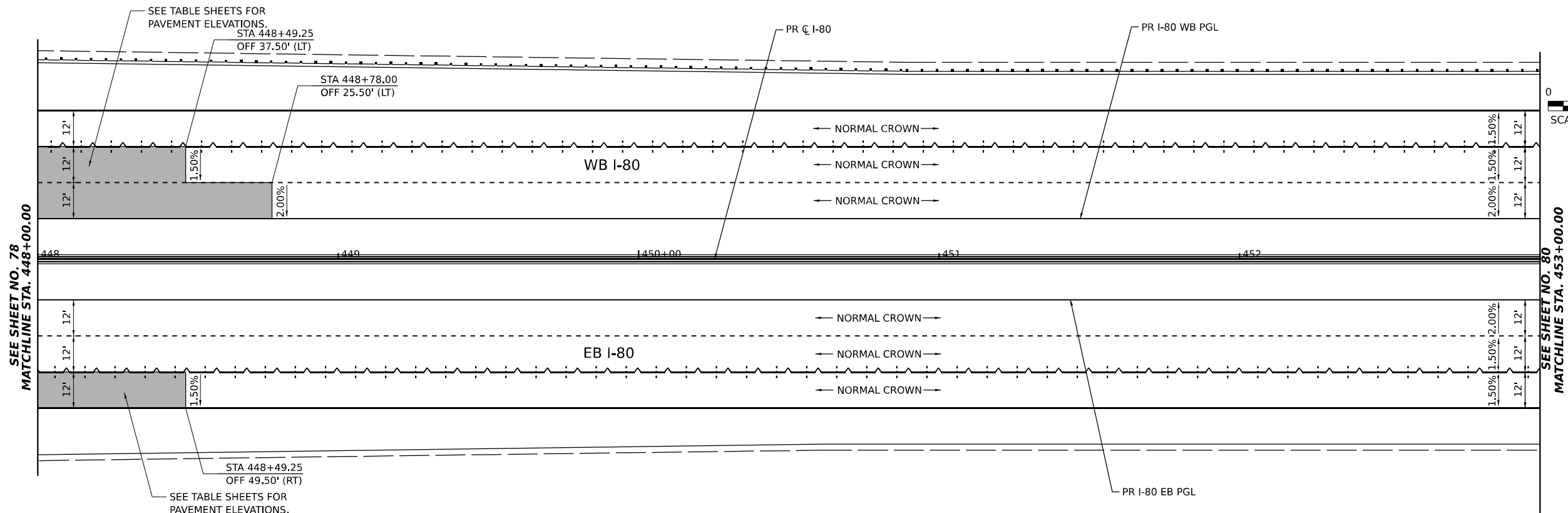

**LEGEND**

- CONSTRUCTION JOINT
  - LONGITUDINAL CONSTRUCTION JOINT
    1. NO. 6 X 2'-6" LONG DEFORMED TIE BARS (EPOXY COATED) FORMED IN PLACE OR MECHANICALLY INSERTED AT 3' C-C (STANDARD 420001-08) OR
    2. NO. 6 X 2' LONG DEFORMED TIE BARS (EPOXY COATED) GROUTED IN PLACE AT 3' C-C (STANDARD 420001-08)
  - TRANSVERSE CONSTRUCTION JOINT
    - 1'-6" LONG DOWEL BARS (EPOXY COATED) AT 1' C-C (STANDARD 420101-05)
- - - - SAWED JOINT (MAINLINE)
  - LONGITUDINAL SAWED JOINT
    - NO. 6 X 2'-6" LONG DEFORMED TIE BARS (EPOXY COATED) AT 3' C-C (STANDARD 420001-08)
  - TRANSVERSE CONTRACTION JOINT
    - 1'-6" LONG DOWEL BARS, 1 1/2" DIAMETER (EPOXY COATED) AT 1' C-C (STANDARD 420001-08)
- - - - SAWED JOINT (RAMPS)
  - LONGITUDINAL SAWED JOINT
    - NO. 6 X 3' LONG DEFORMED TIE BARS AT 1'-6" C-C (DISTRICT STANDARD BD-49)
  - TRANSVERSE CONTRACTION JOINT
    - 1'-6" LONG DOWEL BARS, 1 1/2" DIAMETER (EPOXY COATED) AT 1' C-C (DISTRICT STANDARD BD-49)
- ===== EXPANSION JOINT
  - 1'-6" LONG DOWEL BARS, 1 1/2" DIAMETER (EPOXY COATED) AT 1' C-C (STANDARD 42001-08)
- KEYED JOINT
  - LONGITUDINAL KEYED JOINT WITHOUT TIE BARS
- CONSTRUCTION JOINT AT CROWN
  - LONGITUDINAL CONSTRUCTION JOINT
    1. NO. 6 X 2'-6" LONG DEFORMED TIE BARS (EPOXY COATED) FORMED IN PLACE OR MECHANICALLY INSERTED AT 3'-C-C (SEE ON SHEETS3) OR
    2. NO. 6 X 2' LONG DEFORMED DOWEL BARS (EPOXY COATED) GROUTED IN PLACE AT 3'-C-C (SEE SHEET53)
- PAVEMENT CROSS SLOPE TRANSITIONS

**NOTES:**

1. UNLESS NOTED OTHERWISE, ALL STATIONING AND OFFSETS ARE TAKEN FROM PR CL I-80.
2. FOR PAVEMENT, SHOULDER, AND BARRIER MATERIALS SEE ROADWAY PLANS54TO .63
3. SEE SUPERELEVATION TABLE FOR SHOULDER SLOPES.
4. ADDITIONAL SAWED TRANSVERSE CONTRACTION JOINTS MAY BE REQUIRED IN THE FIELD, AS DIRECTED BY THE ENGINEER. EXACT LOCATIONS TO BE VERIFIED IN THE FIELD AND APPROVED BY THE ENGINEER.
5. ALL TRANSVERSE JOINTS SHALL BE A MAXIMUM OF 15.0 FEET UNLESS OTHERWISE NOTED. SEE STANDARD 420101-05 FOR ADDITIONAL INFORMATION, REGARDING TRANSVERSE JOINT SPACING REQUIREMENTS.
6. SEE STANDARD 420001-08 FOR INFORMATION REGARDING SEALING REQUIREMENTS FOR TRANSVERSE EXPANSION JOINTS.
7. PAVEMENT ROUNDOUTS FOR MANHOLES AND VALVE VAULTS SHALL BE CONSTRUCTED IN ACCORDANCE WITH STANDARD 420111-03.
8. ALL ELEVATIONS NOT SHOWN SHALL FOLLOW THE TYPICAL SECTIONS AND PROFILES.
9. SEE STANDARD 420206-13 FOR ENTRANCE RAMP TERMINAL JOINTING INFORMATION AND 420306-11 FOR EXIT RAMP TERMINAL JOINTING INFORMATION.
10. ALL TRANSVERSE JOINTS ON RAMPS SHALL BE A MAXIMUM OF 12.0 FEET UNLESS OTHERWISE NOTED. SEE DISTRICT DETAIL BD-49 FOR ADDITIONAL INFORMATION, REGARDING TRANSVERSE JOINT SPACING REQUIREMENTS.

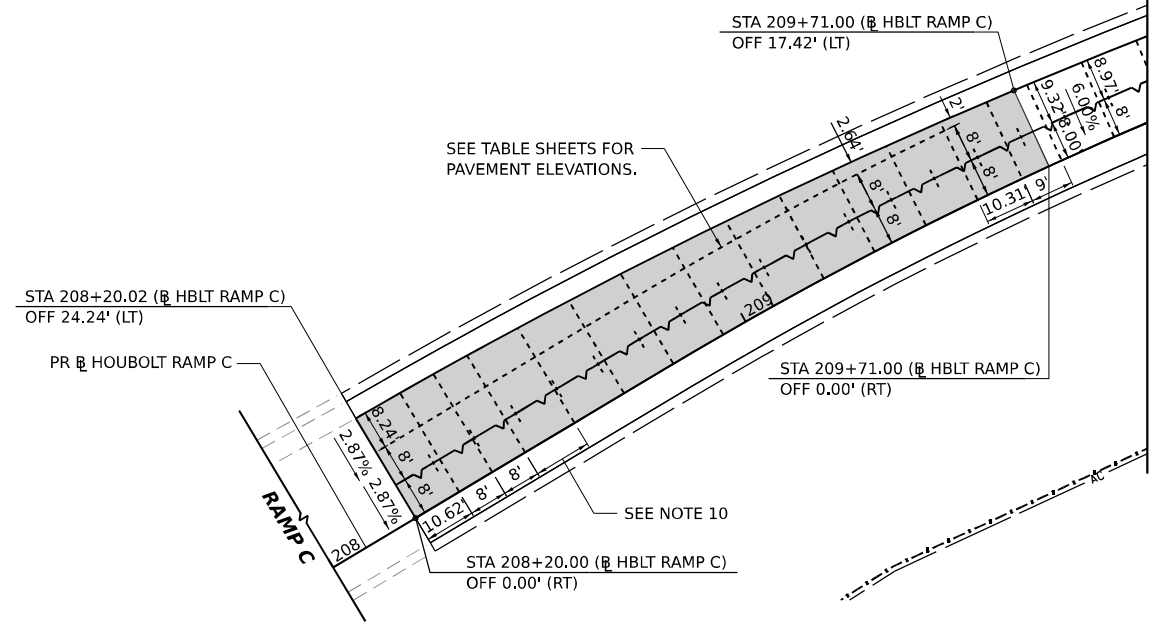

MODEL: BL\_00\_W\_Plan 9 (Sheet) FILE NAME: P:\Projects\Illinois\Projects\2018\CH401\401180022\02-TransSystems-CAD\2022\Drawings\08-Gore and Super\052827-SHTJOINTING.dgn



USER NAME = amkluver	DESIGNED - VLJ	REVISED -
PLOT SCALE = 0.16666633 1/16"	DRAWN - AMK	REVISED -
PLOT DATE = 6/23/2023	CHECKED - JMG	REVISED -
	DATE - 6/26/23	REVISED -

**STATE OF ILLINOIS DEPARTMENT OF TRANSPORTATION**

<b>JOINTING AND SUPERELEVATION PLAN</b>			
<b>I-80</b>			
SCALE: 1"=20'	SHEET 4	OF 10 SHEETS	STA. TO STA.

F.A.I. RTE.	SECTION	COUNTY	TOTAL SHEETS	SHEET NO.
I-80	FAI 80 21 STRUCTURE 6	WILL	898	79
CONTRACT NO. 62R27			ILLINOIS FED. AID PROJECT	



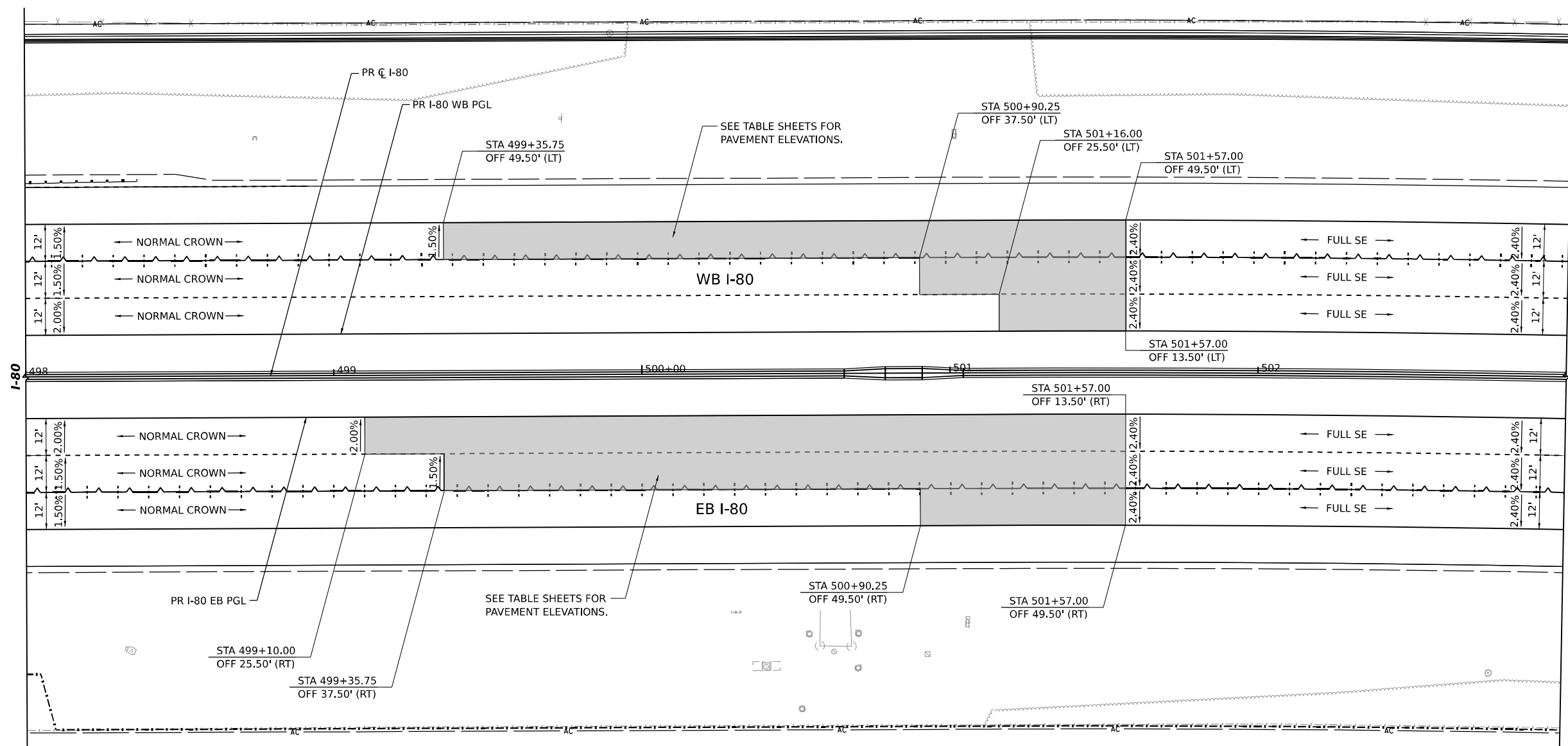
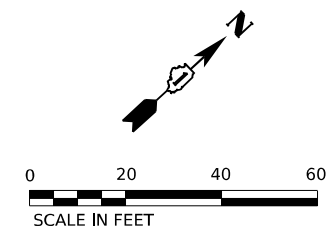

**LEGEND**

- CONSTRUCTION JOINT
  - LONGITUDINAL CONSTRUCTION JOINT
    - 1. NO. 6 X 2'-6" LONG DEFORMED TIE BARS (EPOXY COATED) FORMED IN PLACE OR MECHANICALLY INSERTED AT 3' C-C (STANDARD 420001-10) OR
    - 2. NO. 6 X 2' LONG DEFORMED TIE BARS (EPOXY COATED) GROUTED IN PLACE AT 3' C-C (STANDARD 420001-10)
  - TRANSVERSE CONSTRUCTION JOINT
    - 1'-6" LONG DOWEL BARS (EPOXY COATED) AT 1' C-C (STANDARD 420101-07)
- SAWED JOINT (MAINLINE)
  - LONGITUDINAL SAWED JOINT
    - NO. 6 X 2'-6" LONG DEFORMED TIE BARS (EPOXY COATED) AT 3' C-C (STANDARD 420001-10)
  - TRANSVERSE CONTRACTION JOINT
    - 1'-6" LONG DOWEL BARS, 1 1/2" DIAMETER (EPOXY COATED) AT 1' C-C (STANDARD 420001-10)
- SAWED JOINT (RAMPS)
  - LONGITUDINAL SAWED JOINT
    - NO. 6 X 3' LONG DEFORMED TIE BARS AT 1'-6" C-C (DISTRICT STANDARD BD-49)
  - TRANSVERSE CONTRACTION JOINT
    - 1'-6" LONG DOWEL BARS, 1 1/2" DIAMETER (EPOXY COATED) AT 1' C-C (DISTRICT STANDARD BD-49)
- EXPANSION JOINT
  - 1'-6" LONG DOWEL BARS, 1 1/2" DIAMETER (EPOXY COATED) AT 1' C-C (STANDARD 420001-10)
- KEYED JOINT
  - LONGITUDINAL KEYED JOINT WITHOUT TIE BARS
- CONSTRUCTION JOINT AT CROWN
  - LONGITUDINAL CONSTRUCTION JOINT
    - 1. NO. 6 X 2' LONG DOWEL BARS (EPOXY COATED) FORMED IN PLACE OR MECHANICALLY INSERTED AT 3'-C-C (SEE SHEET 53) OR
    - 2. NO. 6 X 2' LONG DOWEL BARS (EPOXY COATED) GROUTED IN PLACE AT 3' C-C (SEE SHEET 53)

PAVEMENT CROSS SLOPE TRANSITIONS

**NOTES:**

1. UNLESS NOTED OTHERWISE, ALL STATIONS AND OFFSETS ARE TAKEN FROM PR CL I-80.
2. FOR PAVEMENT, SHOULDER, AND BARRIER MATERIALS SEE ROADWAY PLANS 54 TO 63.
3. SEE SUPERELEVATION TABLE FOR SHOULDER SLOPES.
4. ADDITIONAL SAWED TRANSVERSE CONTRACTION JOINTS MAY BE REQUIRED IN THE FIELD, AS DIRECTED BY THE ENGINEER. EXACT LOCATIONS TO BE VERIFIED IN THE FIELD AND APPROVED BY THE ENGINEER.
5. ALL TRANSVERSE JOINTS SHALL BE 15.0 FEET TYPICAL AND MAXIMUM 18.0 FEET UNLESS OTHERWISE NOTED. SEE STANDARD 420101-07 FOR ADDITIONAL INFORMATION, REGARDING TRANSVERSE JOINT SPACING REQUIREMENTS.
6. SEE STANDARD 420001-10 FOR INFORMATION REGARDING SEALING REQUIREMENTS FOR TRANSVERSE EXPANSION JOINTS.
7. PAVEMENT ROUNDOUTS FOR MANHOLES AND VALVE VAULTS SHALL BE CONSTRUCTED IN ACCORDANCE WITH STANDARD 420111-04.
8. ALL ELEVATIONS NOT SHOWN SHALL FOLLOW THE TYPICAL SECTIONS AND PROFILES.
9. SEE STANDARD 420206-13 FOR ENTRANCE RAMP TERMINAL JOINTING INFORMATION AND 420306-11 FOR EXIT RAMP TERMINAL JOINTING INFORMATION.
10. ALL TRANSVERSE JOINTS ON RAMPS SHALL BE A MAXIMUM OF 12.0 FEET UNLESS OTHERWISE NOTED. SEE DISTRICT DETAIL BD-49 FOR ADDITIONAL INFORMATION, REGARDING TRANSVERSE JOINT SPACING REQUIREMENTS.

MODEL: BL\_IP\_80\_W\_Plan 19 (Sheet)  
 FILE NAME: P:\transys\comp\pwr\checked\Documents\Projects\_2018\CH401\401180022\02-TransSystems\CAD\62R27\Sheets\08-Cover and Super\08-SHT-01\I-80.dgn



USER NAME = amkluver	DESIGNED - VLJ	REVISED -
PLOT SCALE = 0.16666633 1/ in.	DRAWN - AMK	REVISED -
PLOT DATE = 6/23/2023	CHECKED - JMG	REVISED -
	DATE - 6/26/23	REVISED -

**STATE OF ILLINOIS  
DEPARTMENT OF TRANSPORTATION**

<b>JOINTING AND SUPERELEVATION PLAN</b>			
<b>I-80</b>			
SCALE: 1"=20'	SHEET 6	OF 10 SHEETS	STA. TO STA.

F.A.I. RTE.	SECTION	COUNTY	TOTAL SHEETS	SHEET NO.
I-80	FAI 80 21 STRUCTURE 6	WILL	898	81
CONTRACT NO. 62R27				
ILLINOIS FED. AID PROJECT				

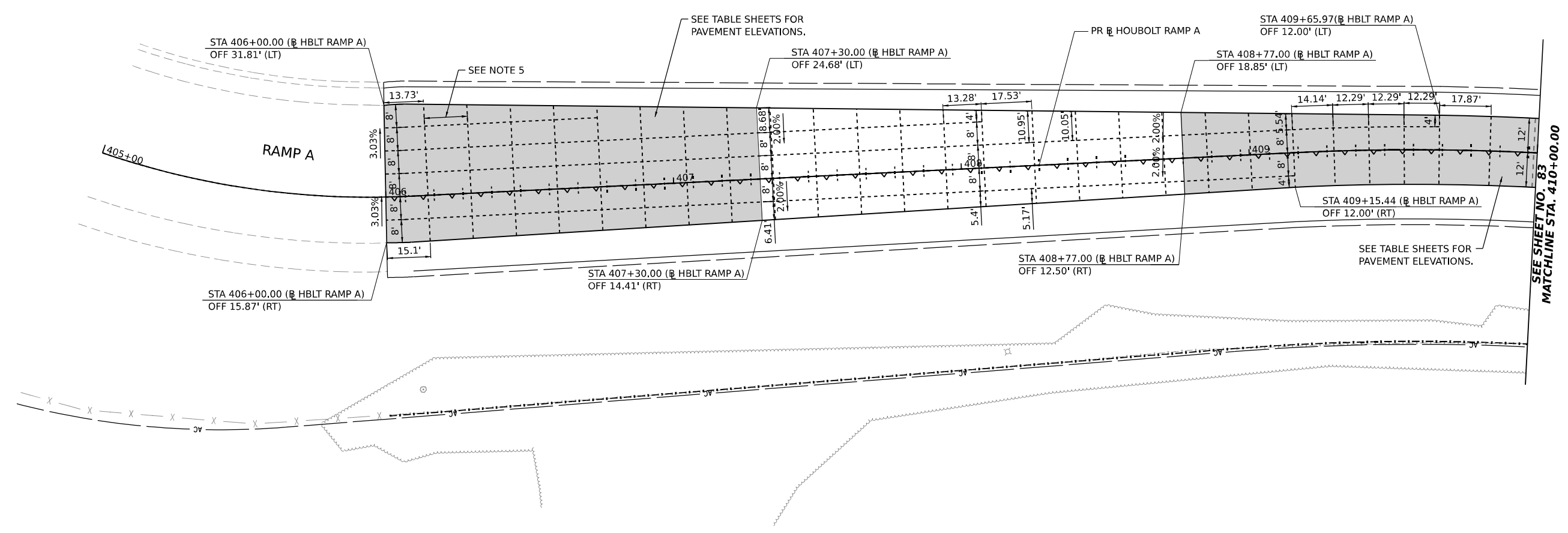

**LEGEND**

- +---+ CONSTRUCTION JOINT
  - LONGITUDINAL CONSTRUCTION JOINT
    - 1. NO. 6 X 2'-6" LONG DEFORMED TIE BARS (EPOXY COATED) FORMED IN PLACE OR MECHANICALLY INSERTED AT 3' C-C (STANDARD 420001-10) OR
    - 2. NO. 6 X 2' LONG DEFORMED TIE BARS (EPOXY COATED) GROUTED IN PLACE AT 3' C-C (STANDARD 420001-10)
  - TRANSVERSE CONSTRUCTION JOINT
    - 1'-6" LONG DOWEL BARS (EPOXY COATED) AT 1' C-C (STANDARD 420101-07)
- SAWED JOINT (MAINLINE)
  - LONGITUDINAL SAWED JOINT
    - NO. 6 X 2'-6" LONG DEFORMED TIE BARS (EPOXY COATED) AT 3' C-C (STANDARD 420001-10)
  - TRANSVERSE CONTRACTION JOINT
    - 1'-6" LONG DOWEL BARS, 1 1/2" DIAMETER (EPOXY COATED) AT 1' C-C (STANDARD 420001-10)
- SAWED JOINT (RAMPS)
  - LONGITUDINAL SAWED JOINT
    - NO. 6 X 3' LONG DEFORMED TIE BARS AT 1'-6" C-C (DISTRICT STANDARD BD-49)
  - TRANSVERSE CONTRACTION JOINT
    - 1'-6" LONG DOWEL BARS, 1 1/2" DIAMETER (EPOXY COATED) AT 1' C-C (DISTRICT STANDARD BD-49)
- EXPANSION JOINT
  - 1'-6" LONG DOWEL BARS, 1 1/2" DIAMETER (EPOXY COATED) AT 1' C-C (STANDARD 420001-10)
- KEYED JOINT
  - LONGITUDINAL KEYED JOINT WITHOUT TIE BARS
- +---+ CONSTRUCTION JOINT AT CROWN
  - LONGITUDINAL CONSTRUCTION JOINT
    - 1. NO. 6 X 2' LONG DOWEL BARS (EPOXY COATED) FORMED IN PLACE OR MECHANICALLY INSERTED AT 3'-C-C (SEE SHEET 53) OR
    - 2. NO. 6 X 2' LONG DOWEL BARS (EPOXY COATED) GROUTED IN PLACE AT 3' C-C (SEE SHEET 53)

PAVEMENT CROSS SLOPE TRANSITIONS

**NOTES:**

1. UNLESS NOTED OTHERWISE, ALL STATIONS AND OFFSETS ARE TAKEN FROM PR CL I-80.
2. FOR PAVEMENT, SHOULDER, AND BARRIER MATERIALS SEE ROADWAY PLANS 54 TO 63.
3. SEE SUPERELEVATION TABLE FOR SHOULDER SLOPES.
4. ADDITIONAL SAWED TRANSVERSE CONTRACTION JOINTS MAY BE REQUIRED IN THE FIELD, AS DIRECTED BY THE ENGINEER. EXACT LOCATIONS TO BE VERIFIED IN THE FIELD AND APPROVED BY THE ENGINEER.
5. ALL TRANSVERSE JOINTS SHALL BE 15.0 FEET TYPICAL AND MAXIMUM 18.0 FEET UNLESS OTHERWISE NOTED. SEE STANDARD 420101-07 FOR ADDITIONAL INFORMATION, REGARDING TRANSVERSE JOINT SPACING REQUIREMENTS.
6. SEE STANDARD 420001-10 FOR INFORMATION REGARDING SEALING REQUIREMENTS FOR TRANSVERSE EXPANSION JOINTS.
7. PAVEMENT ROUNDOUTS FOR MANHOLES AND VALVE VAULTS SHALL BE CONSTRUCTED IN ACCORDANCE WITH STANDARD 420111-04.
8. ALL ELEVATIONS NOT SHOWN SHALL FOLLOW THE TYPICAL SECTIONS AND PROFILES.
9. SEE STANDARD 420206-13 FOR ENTRANCE RAMP TERMINAL JOINTING INFORMATION AND 420306-11 FOR EXIT RAMP TERMINAL JOINTING INFORMATION.
10. ALL TRANSVERSE JOINTS ON RAMPS SHALL BE A MAXIMUM OF 12.0 FEET UNLESS OTHERWISE NOTED. SEE DISTRICT DETAIL BD-49 FOR ADDITIONAL INFORMATION, REGARDING TRANSVERSE JOINT SPACING REQUIREMENTS.

MODEL: BL\_PR\_00\_W\_Plan\_23 (Sheet)  
 FILE NAME: P:\Projects\2022\2022-02-TransSystems-CAD\62R27\Sheets\08-Core and Super\052R27-SHT-JOINTING.dgn

<b>TRANSYSTEMS</b>	USER NAME = amkluver	DESIGNED - VLJ	REVISED -	<b>STATE OF ILLINOIS DEPARTMENT OF TRANSPORTATION</b>	<b>JOINTING AND SUPERELEVATION PLAN</b>			F.A.I. RTE.	SECTION	COUNTY	TOTAL SHEETS	SHEET NO.
	PLOT SCALE = 0.16666633 1/ in.	DRAWN - AMK	REVISED -		<b>HOUBOLT RAMP A</b>			I-80	FAI 80 21 STRUCTURE 6	WILL	898	82
	PLOT DATE = 6/23/2023	CHECKED - JMG	REVISED -		SCALE: 1"=20'			SHEET 7 OF 10 SHEETS		STA. TO STA.		CONTRACT NO. 62R27
	DATE - 6/26/23	REVISED -					ILLINOIS		FED. AID PROJECT			

MODEL: BL\_IP\_00\_W\_Plan\_24 (Sheet)  
 FILE NAME: P:\Projects\2023\Illinois\Transportation\Projects\2023\CH401\401\_180022\02-TransSystems\CAD\2327\Sheets\08-Cover and Super\052R27-SHT-010118.dgn

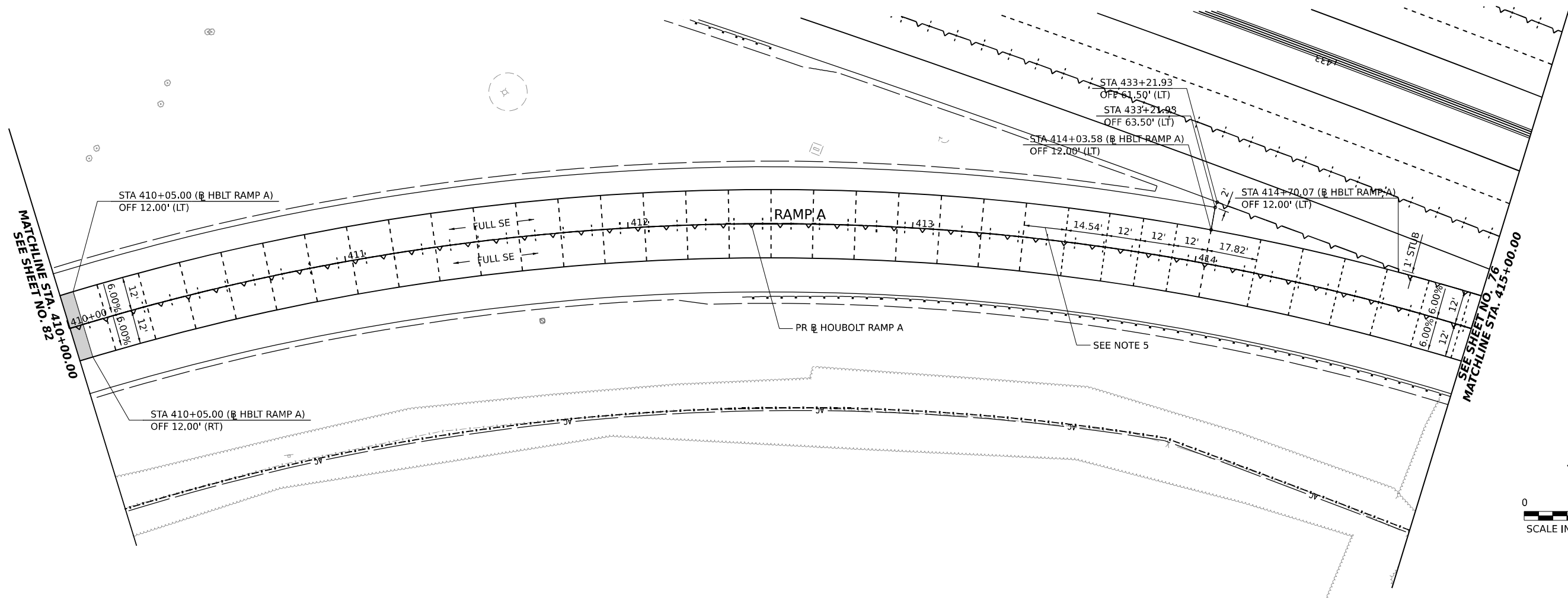

**LEGEND**

- +---+ CONSTRUCTION JOINT
  - LONGITUDINAL CONSTRUCTION JOINT
    - 1. NO. 6 X 2'-6" LONG DEFORMED TIE BARS (EPOXY COATED) FORMED IN PLACE OR MECHANICALLY INSERTED AT 3' C-C (STANDARD 420001-10) OR
    - 2. NO. 6 X 2' LONG DEFORMED TIE BARS (EPOXY COATED) GROUTED IN PLACE AT 3' C-C (STANDARD 420001-10)
  - TRANSVERSE CONSTRUCTION JOINT
    - 1'-6" LONG DOWEL BARS (EPOXY COATED) AT 1' C-C (STANDARD 420101-07)
- SAWED JOINT (MAINLINE)
  - LONGITUDINAL SAWED JOINT
    - NO. 6 X 2'-6" LONG DEFORMED TIE BARS (EPOXY COATED) AT 3' C-C (STANDARD 420001-10)
  - TRANSVERSE CONTRACTION JOINT
    - 1'-6" LONG DOWEL BARS, 1 1/2" DIAMETER (EPOXY COATED) AT 1' C-C (STANDARD 420001-10)
- SAWED JOINT (RAMPS)
  - LONGITUDINAL SAWED JOINT
    - NO. 6 X 3' LONG DEFORMED TIE BARS AT 1'-6" C-C (DISTRICT STANDARD BD-49)
  - TRANSVERSE CONTRACTION JOINT
    - 1'-6" LONG DOWEL BARS, 1 1/2" DIAMETER (EPOXY COATED) AT 1' C-C (DISTRICT STANDARD BD-49)
- EXPANSION JOINT
  - 1'-6" LONG DOWEL BARS, 1 1/2" DIAMETER (EPOXY COATED) AT 1' C-C (STANDARD 420001-10)
- KEYED JOINT
  - LONGITUDINAL KEYED JOINT WITHOUT TIE BARS
- +---+ CONSTRUCTION JOINT AT CROWN
  - LONGITUDINAL CONSTRUCTION JOINT
    - 1. NO. 6 X 2' LONG DOWEL BARS (EPOXY COATED) FORMED IN PLACE OR MECHANICALLY INSERTED AT 3'-C-C (SEE SHEET 53) OR
    - 2. NO. 6 X 2' LONG DOWEL BARS (EPOXY COATED) GROUTED IN PLACE AT 3' C-C (SEE SHEET 53)
- PAVEMENT CROSS SLOPE TRANSITIONS

**NOTES:**

1. UNLESS NOTED OTHERWISE, ALL STATIONS AND OFFSETS ARE TAKEN FROM PR CL I-80.
2. FOR PAVEMENT, SHOULDER, AND BARRIER MATERIALS SEE ROADWAY PLANS 54 TO 63.
3. SEE SUPERELEVATION TABLE FOR SHOULDER SLOPES.
4. ADDITIONAL SAWED TRANSVERSE CONTRACTION JOINTS MAY BE REQUIRED IN THE FIELD, AS DIRECTED BY THE ENGINEER. EXACT LOCATIONS TO BE VERIFIED IN THE FIELD AND APPROVED BY THE ENGINEER.
5. ALL TRANSVERSE JOINTS SHALL BE 15.0 FEET TYPICAL AND MAXIMUM 18.0 FEET UNLESS OTHERWISE NOTED. SEE STANDARD 420101-07 FOR ADDITIONAL INFORMATION, REGARDING TRANSVERSE JOINT SPACING REQUIREMENTS.
6. SEE STANDARD 420001-10 FOR INFORMATION REGARDING SEALING REQUIREMENTS FOR TRANSVERSE EXPANSION JOINTS.
7. PAVEMENT ROUNDOUTS FOR MANHOLES AND VALVE VAULTS SHALL BE CONSTRUCTED IN ACCORDANCE WITH STANDARD 420111-04.
8. ALL ELEVATIONS NOT SHOWN SHALL FOLLOW THE TYPICAL SECTIONS AND PROFILES.
9. SEE STANDARD 420206-13 FOR ENTRANCE RAMP TERMINAL JOINTING INFORMATION AND 420306-11 FOR EXIT RAMP TERMINAL JOINTING INFORMATION.
10. ALL TRANSVERSE JOINTS ON RAMPS SHALL BE A MAXIMUM OF 12.0 FEET UNLESS OTHERWISE NOTED. SEE DISTRICT DETAIL BD-49 FOR ADDITIONAL INFORMATION, REGARDING TRANSVERSE JOINT SPACING REQUIREMENTS.



USER NAME = amkluver	DESIGNED - VLJ	REVISED -
PLOT SCALE = 0.16666633 1/16"	DRAWN - AMK	REVISED -
PLOT DATE = 6/23/2023	CHECKED - JMG	REVISED -
	DATE - 6/26/23	REVISED -

**STATE OF ILLINOIS  
DEPARTMENT OF TRANSPORTATION**

**JOINTING AND SUPERELEVATION PLAN  
HOUBOLT RAMP A**

SCALE: 1"=20'      SHEET 8 OF 10 SHEETS      STA.      TO STA.

F.A.I. RTE.	SECTION	COUNTY	TOTAL SHEETS	SHEET NO.
I-80	FAI 80 21 STRUCTURE 6	WILL	898	83
CONTRACT NO. 62R27				
ILLINOIS   FED. AID PROJECT				

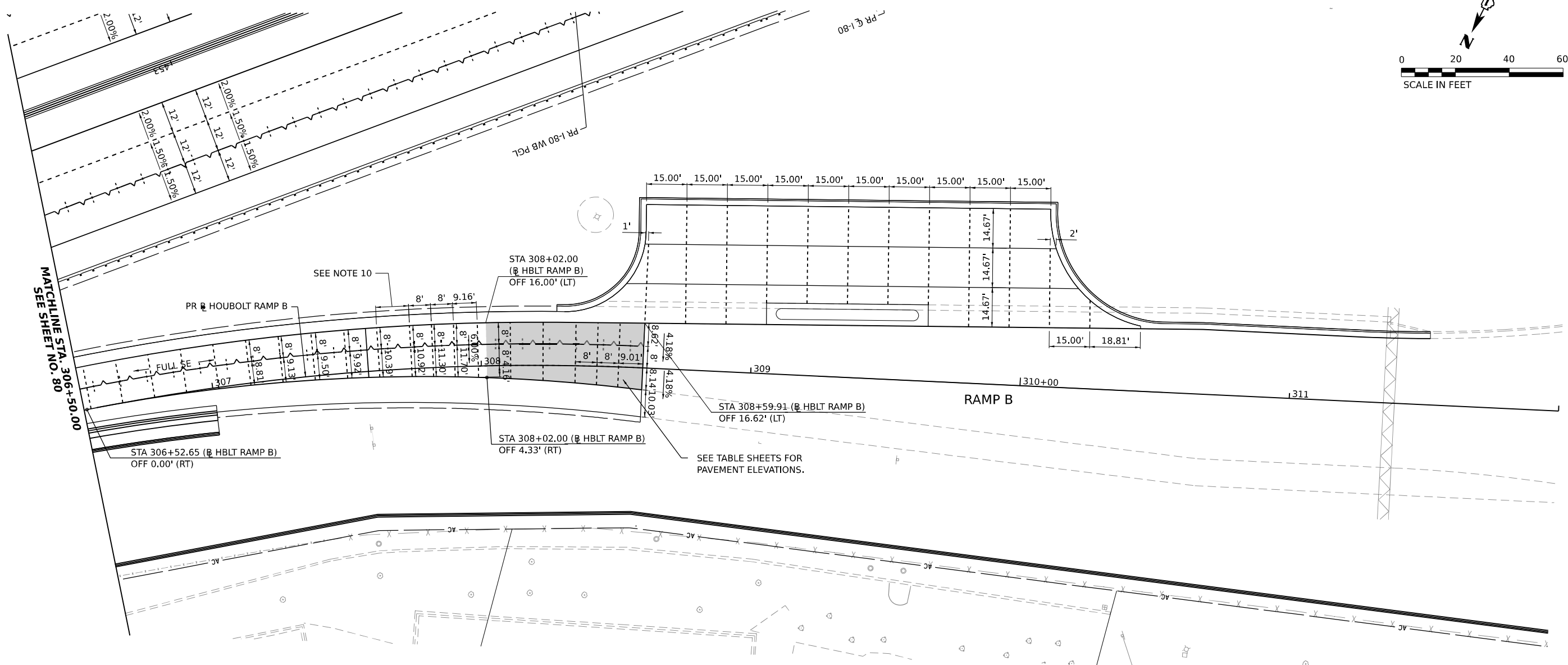
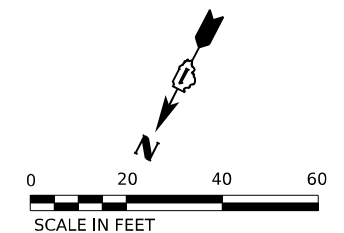

**LEGEND**

- +---+ CONSTRUCTION JOINT
  - LONGITUDINAL CONSTRUCTION JOINT
    - 1. NO. 6 X 2'-6" LONG DEFORMED TIE BARS (EPOXY COATED) FORMED IN PLACE OR MECHANICALLY INSERTED AT 3' C-C (STANDARD 420001-10) OR
    - 2. NO. 6 X 2' LONG DEFORMED TIE BARS (EPOXY COATED) GROUTED IN PLACE AT 3' C-C (STANDARD 420001-10)
  - TRANSVERSE CONSTRUCTION JOINT
    - 1'-6" LONG DOWEL BARS (EPOXY COATED) AT 1' C-C (STANDARD 420101-07)
- SAWED JOINT (MAINLINE)
  - LONGITUDINAL SAWED JOINT
    - NO. 6 X 2'-6" LONG DEFORMED TIE BARS (EPOXY COATED) AT 3' C-C (STANDARD 420001-10)
  - TRANSVERSE CONSTRUCTION JOINT
    - 1'-6" LONG DOWEL BARS, 1 1/2" DIAMETER (EPOXY COATED) AT 1' C-C (STANDARD 420001-10)
- SAWED JOINT (RAMPS)
  - LONGITUDINAL SAWED JOINT
    - NO. 6 X 3' LONG DEFORMED TIE BARS AT 1'-6" C-C (DISTRICT STANDARD BD-49)
  - TRANSVERSE CONSTRUCTION JOINT
    - 1'-6" LONG DOWEL BARS, 1 1/2" DIAMETER (EPOXY COATED) AT 1' C-C (DISTRICT STANDARD BD-49)
- EXPANSION JOINT
  - 1'-6" LONG DOWEL BARS, 1 1/2" DIAMETER (EPOXY COATED) AT 1' C-C (STANDARD 420001-10)
- KEYED JOINT
  - LONGITUDINAL KEYED JOINT WITHOUT TIE BARS
- +---+ CONSTRUCTION JOINT AT CROWN
  - LONGITUDINAL CONSTRUCTION JOINT
    - 1. NO. 6 X 2' LONG DOWEL BARS (EPOXY COATED) FORMED IN PLACE OR MECHANICALLY INSERTED AT 3'-C-C (SEE SHEET 53) OR
    - 2. NO. 6 X 2' LONG DOWEL BARS (EPOXY COATED) GROUTED IN PLACE AT 3' C-C (SEE SHEET 53)
- PAVEMENT CROSS SLOPE TRANSITIONS

**NOTES:**

1. UNLESS NOTED OTHERWISE, ALL STATIONS AND OFFSETS ARE TAKEN FROM PR CL I-80.
2. FOR PAVEMENT, SHOULDER, AND BARRIER MATERIALS SEE ROADWAY PLANS 54 TO 63.
3. SEE SUPERELEVATION TABLE FOR SHOULDER SLOPES.
4. ADDITIONAL SAWED TRANSVERSE CONTRACTION JOINTS MAY BE REQUIRED IN THE FIELD, AS DIRECTED BY THE ENGINEER. EXACT LOCATIONS TO BE VERIFIED IN THE FIELD AND APPROVED BY THE ENGINEER.
5. ALL TRANSVERSE JOINTS SHALL BE 15.0 FEET TYPICAL AND MAXIMUM 18.0 FEET UNLESS OTHERWISE NOTED. SEE STANDARD 420101-07 FOR ADDITIONAL INFORMATION, REGARDING TRANSVERSE JOINT SPACING REQUIREMENTS.
6. SEE STANDARD 420001-10 FOR INFORMATION REGARDING SEALING REQUIREMENTS FOR TRANSVERSE EXPANSION JOINTS.
7. PAVEMENT ROUNDOUTS FOR MANHOLES AND VALVE VAULTS SHALL BE CONSTRUCTED IN ACCORDANCE WITH STANDARD 420111-04.
8. ALL ELEVATIONS NOT SHOWN SHALL FOLLOW THE TYPICAL SECTIONS AND PROFILES.
9. SEE STANDARD 420206-13 FOR ENTRANCE RAMP TERMINAL JOINTING INFORMATION AND 420306-11 FOR EXIT RAMP TERMINAL JOINTING INFORMATION.
10. ALL TRANSVERSE JOINTS ON RAMPS SHALL BE A MAXIMUM OF 12.0 FEET UNLESS OTHERWISE NOTED. SEE DISTRICT DETAIL BD-49 FOR ADDITIONAL INFORMATION, REGARDING TRANSVERSE JOINT SPACING REQUIREMENTS.

MODEL: BL\_PR\_80\_W\_Plan\_25 (Sheet)  
 FILE NAME: P:\Projects\Illinois\Projects\2018\CH401\401\_180022\02-TransSystemsCAD\62R27\Struct\08-Corn and Super\02-25-21\JOINTING.dgn  
 PLOT DATE: 6/23/2023



USER NAME = amkjuver	DESIGNED - VLJ	REVISED -
PLOT SCALE = 0.16666633 1/16"	DRAWN - AMK	REVISED -
PLOT DATE = 6/23/2023	CHECKED - JMG	REVISED -
	DATE - 6/26/23	REVISED -

**STATE OF ILLINOIS  
DEPARTMENT OF TRANSPORTATION**

<b>JOINTING AND SUPERELEVATION PLAN</b>			
<b>HOUBOLT RAMP B</b>			
SCALE: 1"=20'	SHEET 9	OF 10 SHEETS	STA. TO STA.

F.A.I. RTE.	SECTION	COUNTY	TOTAL SHEETS	SHEET NO.
I-80	FAI 80 21 STRUCTURE 6	WILL	898	84
			CONTRACT NO. 62R27	
ILLINOIS   FED. AID PROJECT				

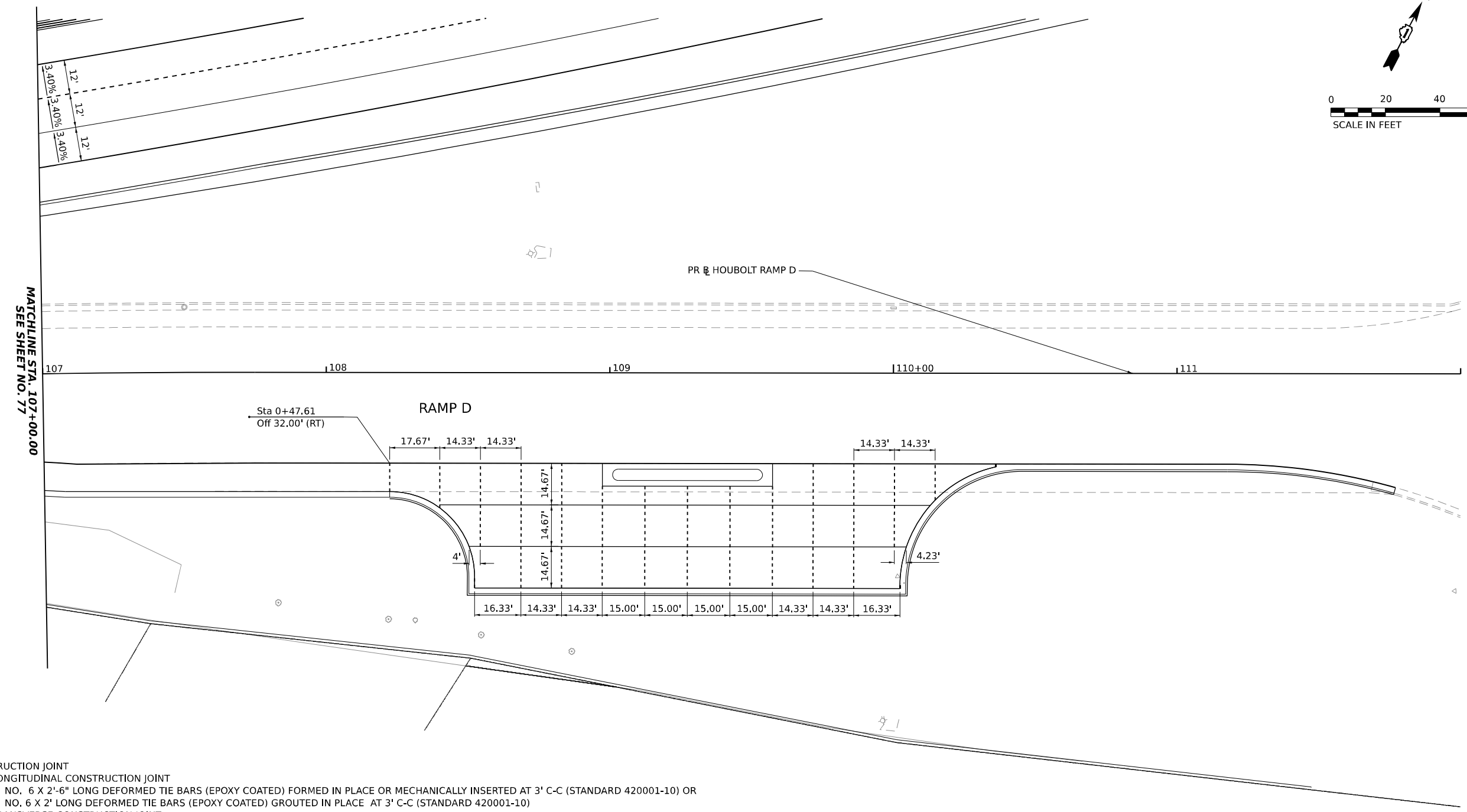
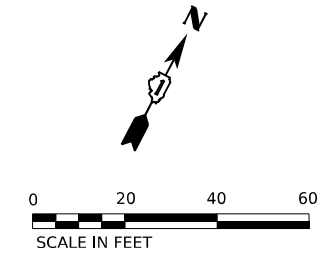

**LEGEND**

- +---+---+ CONSTRUCTION JOINT
  - LONGITUDINAL CONSTRUCTION JOINT
    - 1. NO. 6 X 2'-6" LONG DEFORMED TIE BARS (EPOXY COATED) FORMED IN PLACE OR MECHANICALLY INSERTED AT 3' C-C (STANDARD 420001-10) OR
    - 2. NO. 6 X 2' LONG DEFORMED TIE BARS (EPOXY COATED) GROUTED IN PLACE AT 3' C-C (STANDARD 420001-10)
  - TRANSVERSE CONSTRUCTION JOINT
    - 1'-6" LONG DOWEL BARS (EPOXY COATED) AT 1' C-C (STANDARD 420101-07)
- SAWED JOINT (MAINLINE)
  - LONGITUDINAL SAWED JOINT
    - NO. 6 X 2'-6" LONG DEFORMED TIE BARS (EPOXY COATED) AT 3' C-C (STANDARD 420001-10)
  - TRANSVERSE CONTRACTION JOINT
    - 1'-6" LONG DOWEL BARS, 1 1/2" DIAMETER (EPOXY COATED) AT 1' C-C (STANDARD 420001-10)
- SAWED JOINT (RAMPS)
  - LONGITUDINAL SAWED JOINT
    - NO. 6 X 3' LONG DEFORMED TIE BARS AT 1'-6" C-C (DISTRICT STANDARD BD-49)
  - TRANSVERSE CONTRACTION JOINT
    - 1'-6" LONG DOWEL BARS, 1 1/2" DIAMETER (EPOXY COATED) AT 1' C-C (DISTRICT STANDARD BD-49)
- EXPANSION JOINT
  - 1'-6" LONG DOWEL BARS, 1 1/2" DIAMETER (EPOXY COATED) AT 1' C-C (STANDARD 420001-10)
- KEYED JOINT
  - LONGITUDINAL KEYED JOINT WITHOUT TIE BARS
- +---+---+ CONSTRUCTION JOINT AT CROWN
  - LONGITUDINAL CONSTRUCTION JOINT
    - 1. NO. 6 X 2' LONG DOWEL BARS (EPOXY COATED) FORMED IN PLACE OR MECHANICALLY INSERTED AT 3'-C-C (SEE SHEET 53) OR
    - 2. NO. 6 X 2' LONG DOWEL BARS (EPOXY COATED) GROUTED IN PLACE AT 3' C-C (SEE SHEET 53)

**NOTES:**

1. UNLESS NOTED OTHERWISE, ALL STATIONS AND OFFSETS ARE TAKEN FROM PR CL I-80.
2. FOR PAVEMENT, SHOULDER, AND BARRIER MATERIALS SEE ROADWAY PLANS 54 TO 63.
3. SEE SUPERELEVATION TABLE FOR SHOULDER SLOPES.
4. ADDITIONAL SAWED TRANSVERSE CONTRACTION JOINTS MAY BE REQUIRED IN THE FIELD, AS DIRECTED BY THE ENGINEER. EXACT LOCATIONS TO BE VERIFIED IN THE FIELD AND APPROVED BY THE ENGINEER.
5. ALL TRANSVERSE JOINTS SHALL BE 15.0 FEET TYPICAL AND MAXIMUM 18.0 FEET UNLESS OTHERWISE NOTED. SEE STANDARD 420101-07 FOR ADDITIONAL INFORMATION, REGARDING TRANSVERSE JOINT SPACING REQUIREMENTS.
6. SEE STANDARD 420001-10 FOR INFORMATION REGARDING SEALING REQUIREMENTS FOR TRANSVERSE EXPANSION JOINTS.
7. PAVEMENT ROUNDOUTS FOR MANHOLES AND VALVE VAULTS SHALL BE CONSTRUCTED IN ACCORDANCE WITH STANDARD 420111-04.
8. ALL ELEVATIONS NOT SHOWN SHALL FOLLOW THE TYPICAL SECTIONS AND PROFILES.
9. SEE STANDARD 420206-13 FOR ENTRANCE RAMP TERMINAL JOINTING INFORMATION AND 420306-11 FOR EXIT RAMP TERMINAL JOINTING INFORMATION.
10. ALL TRANSVERSE JOINTS ON RAMPS SHALL BE A MAXIMUM OF 12.0 FEET UNLESS OTHERWISE NOTED. SEE DISTRICT DETAIL BD-49 FOR ADDITIONAL INFORMATION, REGARDING TRANSVERSE JOINT SPACING REQUIREMENTS.

MODEL: BL\_IP\_00\_W\_Plan\_26 (Sheet) FILE NAME: P:\transys\comp\ppl\checked\Documents\Projects\_2018\CI-401\401180022\02-TransSystems\CAD\62R27\Sheets\08-Cover and Super\052R27-SHT-JOINTING.dgn

<b>TRANSYSTEMS</b>	USER NAME = amkluver	DESIGNED - VLJ	REVISED -	<b>STATE OF ILLINOIS DEPARTMENT OF TRANSPORTATION</b>	<b>JOINTING AND SUPERELEVATION PLAN HOUBOLT RAMP D</b>				F.A.I. RTE.	SECTION	COUNTY	TOTAL SHEETS	SHEET NO.
	PLOT SCALE = 39.99992000' / in.	CHECKED - JMG	REVISED -		I-80	FAI 80 21 STRUCTURE 6	WILL	898	85	CONTRACT NO. 62R27			
	PLOT DATE = 6/23/2023	DATE - 6/26/23	REVISED -		SCALE: 1"=20'	SHEET 10	OF 10 SHEETS	STA.	TO STA.	ILLINOIS   FED. AID PROJECT			

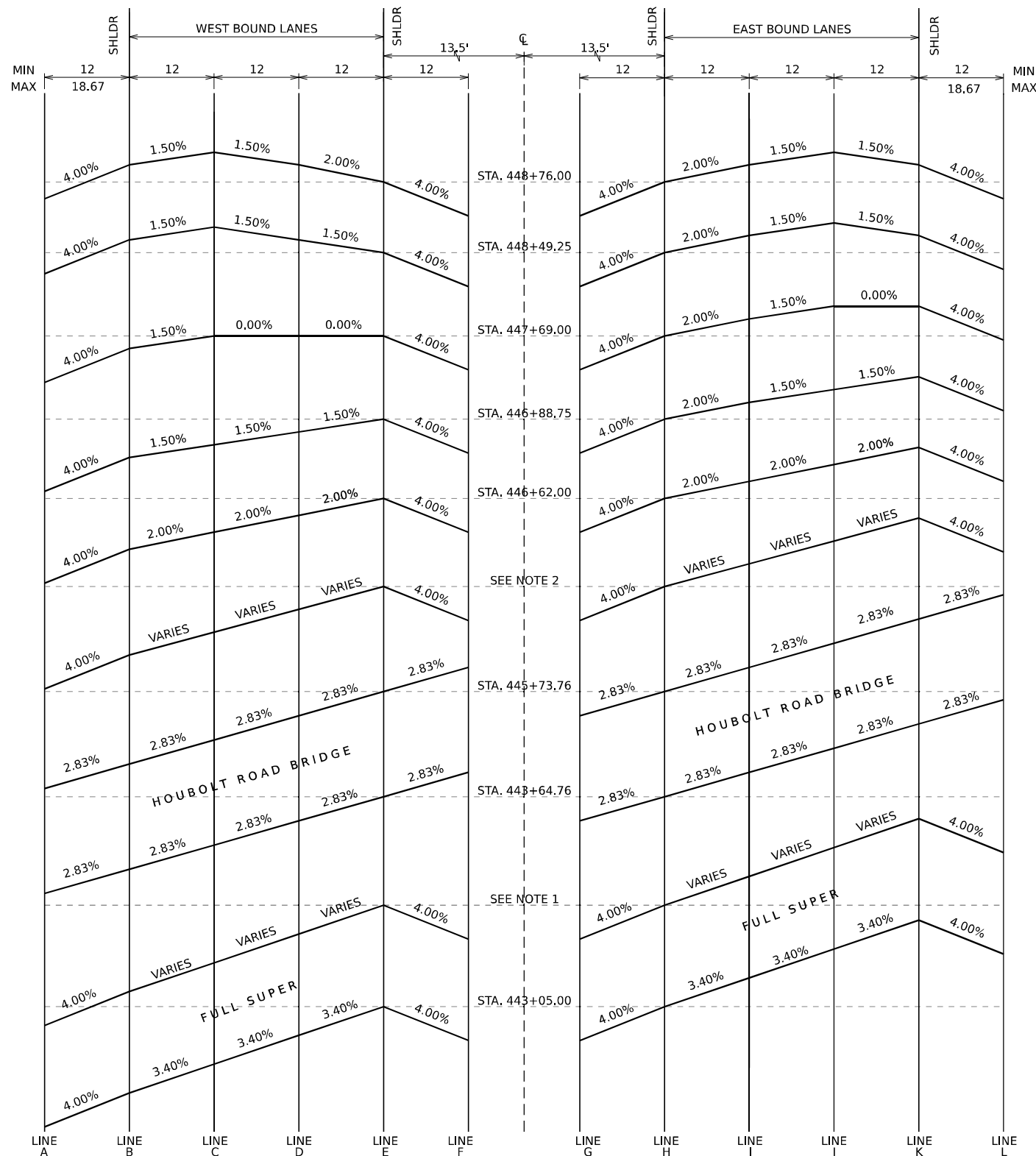

**S.E. TRANSITION SECTIONS CURVE 1**

STATION	WB OUTSIDE SHLD WIDTH	SUPERELEVATION TRANSITIONS												EB OUTSIDE SHLD WIDTH
		ELEVATIONS AT LOCATIONS												
FULL SUPER														
A	B	C	D	E	F	G	H	I	J	K	L			
440+19.73	13.914	599.319	599.876	600.284	600.692	601.100	600.620	599.978	600.458	600.866	601.274	601.682	601.112	14.242
440+25.00	13.984	599.428	599.987	600.395	600.803	601.211	600.731	600.069	600.549	600.957	601.365	601.773	601.217	14.313
440+50.00	14.317	599.925	600.498	600.906	601.314	601.722	601.242	600.491	600.971	601.379	601.787	602.195	601.704	14.649
440+75.00	14.650	600.398	600.984	601.392	601.800	602.208	601.728	600.892	601.372	601.780	602.188	602.596	602.174	14.986
441+00.00	14.983	600.846	601.445	601.853	602.261	602.669	602.189	601.274	601.754	602.162	602.570	602.978	602.628	15.322
441+25.00	15.317	601.267	601.880	602.288	602.696	603.104	602.624	601.636	602.116	602.524	602.932	603.340	603.067	15.658
441+50.00	15.649	601.665	602.291	602.699	603.107	603.515	603.035	601.979	602.459	602.867	603.275	603.683	603.489	15.994
441+50.12	15.650	601.667	602.293	602.701	603.109	603.517	603.037	601.980	602.460	602.868	603.276	603.684	603.491	15.996
441+75.00	15.981	602.037	602.676	603.084	603.492	603.900	603.519	602.302	602.782	603.190	603.598	604.006	603.896	16.330
442+00.00	16.314	602.383	603.036	603.444	603.852	604.260	603.979	602.605	603.085	603.493	603.901	604.309	604.286	16.667
442+25.00	16.647	602.785	603.371	603.779	604.187	604.595	604.174	602.888	603.368	603.776	604.184	604.592	604.659	17.003
442+50.00	16.980	603.002	603.681	604.089	604.497	604.905	604.824	603.152	603.632	604.040	604.448	604.856	605.017	17.339
442+75.00	17.313	603.273	603.966	604.374	604.782	605.190	605.209	603.396	603.876	604.284	604.692	605.100	605.359	17.675
443+00.00	17.646	603.520	604.226	604.634	605.042	605.450	605.569	603.621	604.101	604.509	604.917	605.325	605.685	18.011
443+05.00	17.713	603.566	604.275	604.683	605.091	605.499	605.638	603.663	604.143	604.551	604.959	605.367	605.748	18.079
443+09.76	17.776	603.625	604.336	604.739	605.141	605.544	605.702	603.703	604.183	604.586	604.988	605.391	605.792	18.144
443+15.56	17.855	603.719	604.411	604.807	605.203	605.599	605.780	603.751	604.231	604.627	605.023	605.419	605.844	18.222
443+25.00	17.979	603.868	604.529	604.914	605.299	605.684	605.903	603.863	604.306	604.691	605.076	605.461	605.927	18.347
443+38.73	18.160	604.079	604.694	605.063	605.433	605.802	606.076	604.020	604.410	604.779	605.149	605.518	606.042	18.527
443+50.00	18.311	604.249	604.825	605.181	605.538	605.894	606.213	604.145	604.491	604.847	605.204	605.560	606.089	18.667
443+51.56	18.333	604.272	604.842	605.197	605.551	605.906	606.246	604.162	604.502	604.857	605.211	605.566	606.094	18.667
443+55.12	18.382	604.324	604.882	605.233	605.583	605.934	606.274	604.200	604.526	604.877	605.227	605.578	606.106	18.667
443+64.76	18.513	604.643	604.987	605.327	605.666	606.006	606.346	604.251	604.591	604.931	605.270	605.610	606.138	18.667
443+75.00	18.667	604.531	605.059	605.399	605.738	606.078	606.418	604.316	604.656	604.996	605.335	605.675	606.203	18.667
444+00.00	18.667	604.690	605.218	605.558	605.897	606.237	606.577	604.462	604.802	605.142	605.481	605.821	606.349	18.667
444+25.00	18.667	604.824	605.352	605.692	606.031	606.371	606.711	604.588	604.928	605.268	605.607	605.947	606.475	18.667
444+50.00	18.667	604.933	605.461	605.801	606.140	606.480	606.820	604.695	605.035	605.375	605.714	606.054	606.582	18.667
444+75.00	18.667	605.017	605.545	605.885	606.224	606.564	606.904	604.782	605.122	605.462	605.801	606.141	606.669	18.667
445+00.00	18.667	605.075	605.603	605.943	606.282	606.622	606.962	604.849	605.189	605.529	605.868	606.208	606.736	18.667
445+25.00	18.667	605.109	605.637	605.977	606.316	606.656	606.996	604.896	605.236	605.576	605.915	606.255	606.783	18.667
445+50.00	18.667	605.117	605.645	605.985	606.324	606.664	607.004	604.924	605.264	605.604	605.943	606.283	606.811	18.667
445+73.76	18.667	605.102	605.630	605.970	606.309	606.649	606.989	604.932	605.272	605.612	605.951	606.291	606.814	18.501
445+75.00	18.667	605.104	605.632	605.971	606.309	606.647	606.987	604.932	605.272	605.610	605.948	606.287	606.805	18.485
445+83.38	18.667	605.121	605.650	605.979	606.307	606.636	606.976	604.930	605.270	605.599	605.927	606.256	606.738	18.373
445+87.14	18.667	605.128	605.657	605.981	606.306	606.630	606.970	604.915	605.269	605.593	605.918	606.242	606.709	18.323
446+00.00	18.546	605.151	605.676	605.986	606.296	606.606	606.894	604.856	605.260	605.570	605.880	606.190	606.602	18.151
446+00.84	18.534	605.152	605.677	605.986	606.295	606.604	606.899	604.852	605.260	605.569	605.878	606.187	606.595	18.140
446+19.38	18.286	605.102	605.692	605.980	606.268	606.556	606.767	604.758	605.238	605.526	605.814	606.102	606.434	17.892
446+25.00	18.211	605.084	605.694	605.975	606.257	606.539	606.727	604.749	605.229	605.511	605.793	606.074	606.383	17.817
446+50.00	17.876	604.991	605.685	605.939	606.192	606.446	606.537	604.698	605.178	605.432	605.685	605.939	606.148	17.484
446+55.52	17.803	604.969	605.681	605.928	606.176	606.423	606.489	604.684	605.164	605.411	605.659	605.906	606.094	17.410
446+62.00	17.716	604.964	605.673	605.913	606.153	606.393	606.433	604.667	605.147	605.387	605.627	605.867	606.030	17.324
446+75.00	17.542	604.995	605.696	605.907	606.118	606.329	606.317	604.628	605.108	605.348	605.559	605.770	605.884	17.150
446+88.75	17.358	605.019	605.713	605.893	606.073	606.254	606.187	604.581	605.061	605.301	605.481	605.661	605.723	16.967
447+00.00	17.207	605.007	605.696	605.876	606.030	606.186	606.074	604.538	605.018	605.258	605.438	605.593	605.614	16.817
447+25.00	16.872	604.965	605.640	605.820	605.919	606.019	605.807	604.428	604.908	605.148	605.328	605.427	605.359	16.483
447+50.00	16.538	604.897	605.559	605.739	605.782	605.826	605.514	604.298	604.778	605.018	605.198	605.241	605.088	16.150
447+69.00	16.283	604.832	605.483	605.663	605.663	605.663	605.276	604.186	604.666	604.906	605.086	605.086	604.871	15.896
447+75.00	16.203	604.804	605.453	605.633	605.619	605.608	605.197	604.149	604.629	604.869	605.049	605.036	604.802	15.816
447+92.14	15.974	604.726	605.365	605.545	605.493	605.444	604.964	604.035	604.515	604.755	604.935	604.883	604.595	15.587
448+00.00	15.869	604.686	605.321	605.501	605.432	605.365	604.885	603.980	604.460	604.700	604.880	604.810	604.499	15.482
448+25.00	15.534	604.543	605.165	605.345	605.219	605.097	604.617	604.271	604.791	604.691	604.691	604.565	604.179	15.149
448+49.25	15.207	604.385	604.993	605.173	604.993	604.813	604.333	603.590	604.070	604.310	604.490	604.310	603.855	14.825
448+50.00	15.199	604.374	604.982	605.162	604.982	604.804	604.324	603.583	604.063	604.303	604.483	604.303	603.846	14.815
448+75.00	14.865	604.124	604.718	604.898	604.718	604.485	604.005	603.355	603.835	604.075	604.255	604.075	603.551	14.482
448+78.00	14.824	604.093	604.686	604.866	604.686	604.446	603.966	603.326	603.806	604.046	604.226	604.046	603.514	14.442
448+92.76	14.627	603.899	604.484	604.664	604.484	604.244	603.764	603.181	603.661	603.901	604.081	603.901	603.331	14.245
449+00.00	14.530	603.801	604.382	604.562	604.382	604.142	603.662	603.108	603.588	603.828	604.008	603.828	603.262	14.148

- NOTES**
- SHOULDER SLOPE TRANSITIONS TO THE WEST APPROACH SLAB ARE AS FOLLOWS:
    - EASTBOUND OUTSIDE SHOULDER -4.00% TO 2.83% FROM STA 440+19.73 TO STA 443+38.73
    - EASTBOUND INSIDE SHOULDER -4.00% TO -2.83% FROM STA 443+15.56 TO STA 443+51.56
    - WESTBOUND INSIDE SHOULDER -4.00% TO 2.83% FROM STA 441+50.12 TO STA 443+55.12
    - WESTBOUND OUTSIDE SHOULDER -4.00% TO -2.83% FROM STA 443+09.76 TO STA 443+64.76
  - SHOULDER SLOPE TRANSITIONS TO THE EAST APPROACH SLAB ARE AS FOLLOWS:
    - EASTBOUND OUTSIDE SHOULDER 2.83% TO -4.00% FROM STA 445+73.76 TO STA 448+92.76
    - EASTBOUND INSIDE SHOULDER -2.83% TO -4.00% FROM STA 445+83.38 TO STA 446+19.38
    - WESTBOUND INSIDE SHOULDER 2.83% TO -4.00% FROM STA 445+87.14 TO STA 447+92.14
    - WESTBOUND OUTSIDE SHOULDER -2.83% TO -4.00% FROM STA 446+00.52 TO STA 446+55.52

MODEL: C:\p1\transystems\pwworkspace\transystems\pwworkspace\Documents\Projects\2018\CH401180022\02-Transystems\CH401180022-SHT-SUPERELEVATION.DWG  
 FILE NAME: p1\transystems\pwworkspace\transystems\pwworkspace\Documents\Projects\2018\CH401180022\02-Transystems\CH401180022-SHT-SUPERELEVATION.DWG



USER NAME = amkluver	DESIGNED - VLJ	REVISED -
	DRAWN - AMK	REVISED -
PLOT SCALE = 19.99996000' / in.	CHECKED - JMG	REVISED -
PLOT DATE = 6/23/2023	DATE - 6/26/23	REVISED -

**STATE OF ILLINOIS**  
**DEPARTMENT OF TRANSPORTATION**

**SUPERELEVATION TRANSITION DIAGRAMS**  
**I-80**  
 SCALE: NONE      SHEET 1 OF 6 SHEETS      STA. TO STA.

F.A.I. RTE
------------



MODEL: Curve 2 Approach  
 FILE NAME: p:\transys\comp\pw\beet\transys\comp\pw\beet\Documents\Projects\_2018\01401180022\02-TransSystems\CAD\62R27\Struct\08-Curve and Super\052R27-SHT-SUPERELEVATION.DWG

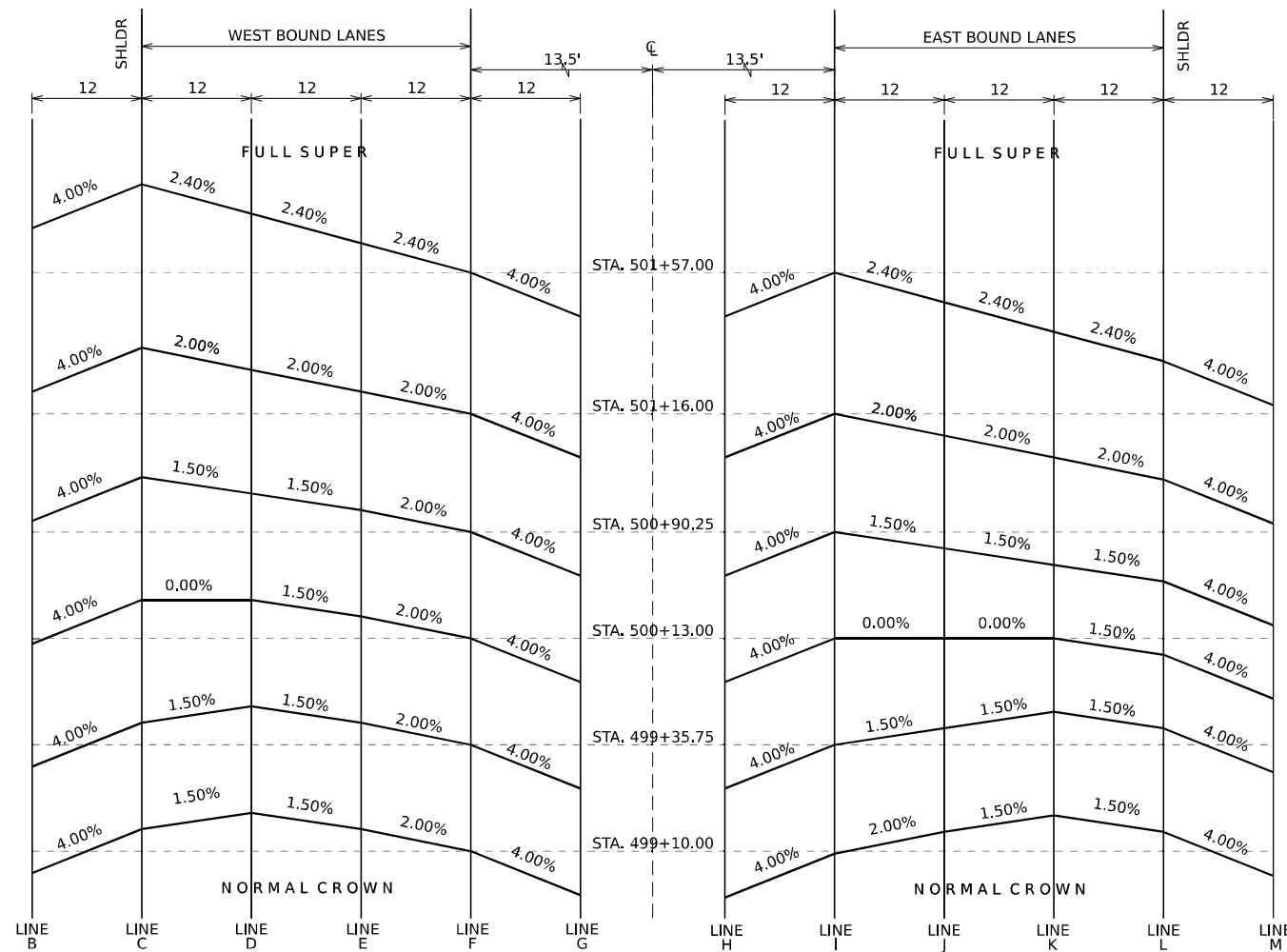

**S.E. TRANSITION SECTIONS CURVE 2 APPROACH**

SUPERELEVATION TRANSITIONS												
STATION	ELEVATIONS AT LOCATIONS											
	B	C	D	E	F	G	H	I	J	K	L	M
499+10.00	596.030	596.510	596.690	596.510	596.270	595.790	595.790	596.270	596.510	596.690	596.510	596.030
499+25.00	596.075	596.555	596.735	596.555	596.315	595.835	595.835	596.315	596.520	596.700	596.520	596.040
499+35.75	596.107	596.587	596.767	596.587	596.347	595.867	595.867	596.347	596.527	596.707	596.527	596.047
499+50.00	596.183	596.663	596.810	596.630	596.390	595.910	595.910	596.390	596.537	596.684	596.504	596.024
499+75.00	596.316	596.796	596.885	596.705	596.465	595.985	595.985	596.465	596.554	596.642	596.462	595.982
500+00.00	596.450	596.930	596.960	596.780	596.540	596.060	596.060	596.540	596.570	596.601	596.421	595.941
500+13.00	596.519	596.999	596.999	596.819	596.579	596.099	596.099	596.579	596.579	596.579	596.399	595.919
500+25.00	596.583	597.063	597.035	596.855	596.615	596.135	596.135	596.615	596.587	596.559	596.379	595.899
500+50.00	596.716	597.196	597.110	596.930	596.690	596.210	596.210	596.690	596.604	596.518	596.338	595.858
500+75.00	596.849	597.329	597.185	597.005	596.765	596.285	596.285	596.765	596.621	596.476	596.296	595.816
500+90.25	596.931	597.411	597.231	597.051	596.811	596.331	596.331	596.811	596.631	596.451	596.271	595.791
501+00.00	597.005	597.485	597.283	597.080	596.840	596.360	596.360	596.840	596.637	596.435	596.239	595.759
501+16.00	597.128	597.608	597.368	597.128	596.888	596.408	596.408	596.888	596.648	596.408	596.168	595.688
501+25.00	597.187	597.667	597.416	597.166	596.915	596.435	596.435	596.915	596.664	596.414	596.163	595.683
501+50.00	597.337	597.817	597.550	597.270	596.990	596.510	596.510	596.990	596.710	596.430	596.151	595.671
501+57.00	597.395	597.875	597.587	597.299	597.011	596.531	596.531	597.011	596.723	596.435	596.147	595.667
501+75.00	597.449	597.929	597.641	597.353	597.065	596.585	596.585	597.065	596.777	596.489	596.201	595.721

FULL SUPER



USER NAME = amkluver	DESIGNED - VLJ	REVISED -
PLOT SCALE = 19.99996000' / in.	DRAWN - AMK	REVISED -
PLOT DATE = 6/23/2023	CHECKED - JMG	REVISED -
	DATE - 6/26/23	REVISED -

**STATE OF ILLINOIS  
DEPARTMENT OF TRANSPORTATION**

**SUPERELEVATION TRANSITION DIAGRAMS  
I-80**

SCALE: NONE SHEET 2 OF 6 SHEETS STA. TO STA.

F.A.I. RTE.	SECTION	COUNTY	TOTAL SHEETS	SHEET NO.
I-80	FAI 80 21 STRUCTURE 6	WILL	898	87
ILLINOIS FED. AID PROJECT			CONTRACT NO. 62R27	

MODEL: Runnig A  
 FILE NAME: p:\transys\transys\comp\pw-1\hosed\Documents\Projects\_2013\C401401180022\02-Trans\Systems\CAD\23\27\Struct\08-Gore and Super\05-PEEID\06RAM

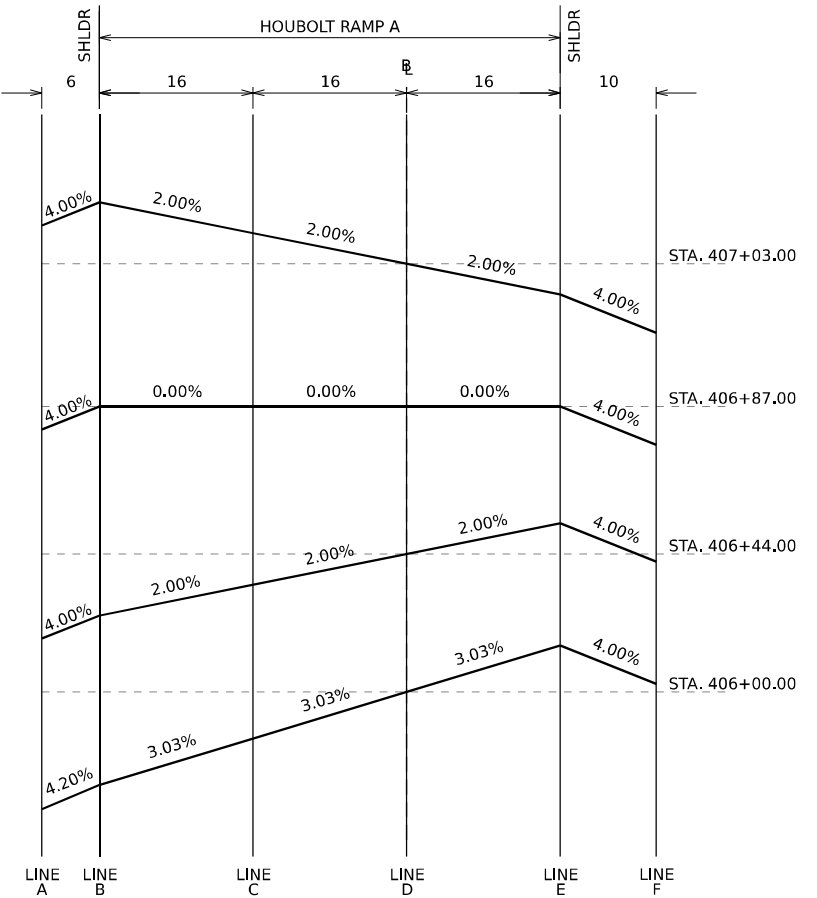
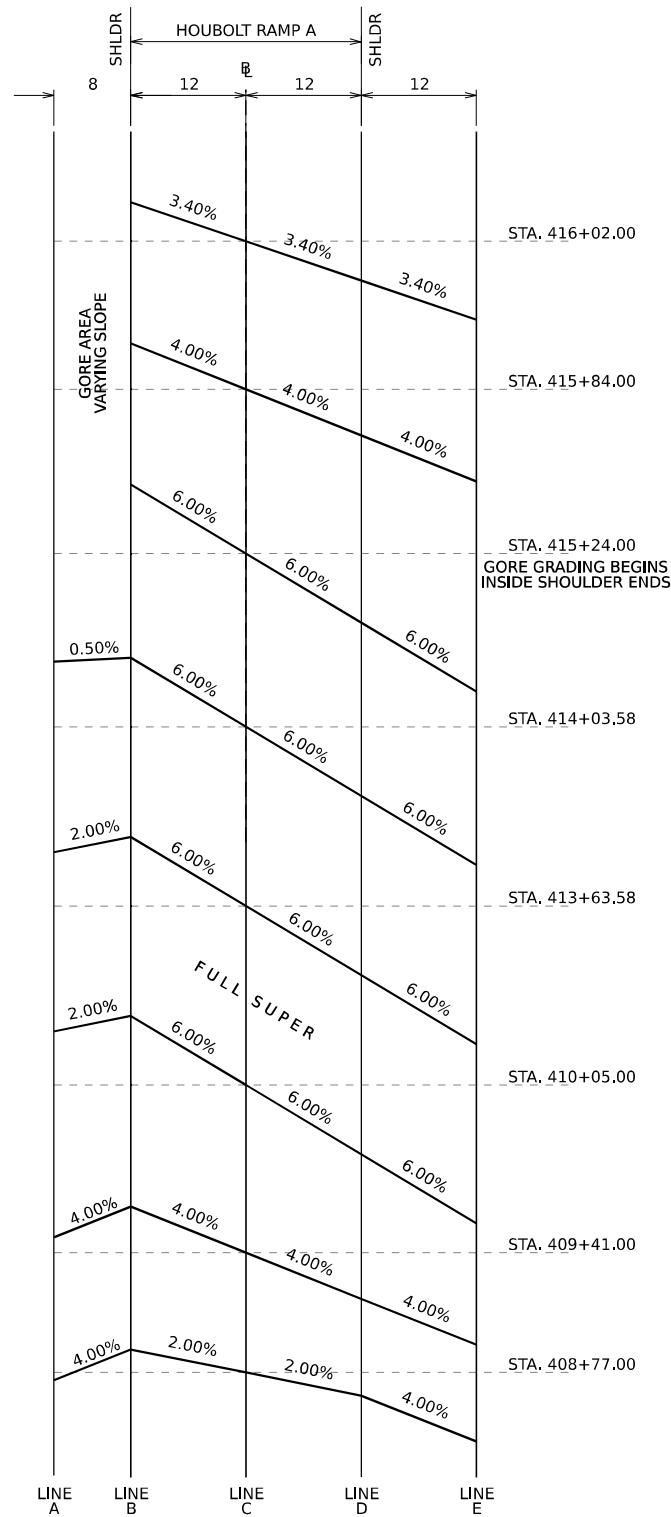

**S.E. TRANSITION SECTIONS HOUBOLT RAMP A**

SUPERELEVATION TRANSITIONS								
STATION	INSIDE SHLD WIDTH	ELEVATIONS AT LOCATIONS						OUTSIDE SHLD WIDTH
		A	B	C	D	E	F	
406+00.00	6.00	587.081	587.333	587.812	588.297	588.777	588.371	10.13
406+25.00	6.10	587.765	588.014	588.378	588.772	589.158	588.753	10.11
406+44.00	6.21	588.288	588.536	588.811	589.133	589.444	589.034	10.23
406+50.00	6.24	588.490	588.739	588.97	589.247	589.513	589.102	10.27
406+75.00	6.38	589.311	589.566	589.632	589.722	589.806	589.389	10.44
406+87.00	6.45	589.692	589.950	589.95	589.950	589.950	589.530	10.51
407+00.00	6.69	590.357	590.625	590.458	590.197	589.956	589.532	10.60
407+03.00	6.54	590.518	590.780	590.575	590.254	589.959	589.534	10.62

SUPERELEVATION TRANSITIONS							
STATION	INSIDE SHLD WIDTH	ELEVATIONS AT LOCATIONS					OUTSIDE SHLD WIDTH
		A	B	C	D	E	
408+77.00	7.50	592.557	592.857	592.540	592.290	591.820	11.75
409+00.00	7.63	592.697	593.002	592.605	592.270	591.796	11.84
409+25.00	7.77	592.764	593.075	592.611	592.187	591.709	11.94
409+41.00	7.86	592.759	593.073	592.578	592.098	591.618	12.00
409+50.00	7.88	592.783	593.076	592.548	592.034	591.521	12.00
409+75.00	7.93	592.801	593.035	592.418	591.811	591.203	12.00
410+00.00	7.99	592.750	592.922	592.219	591.518	590.817	12.00
410+05.00	8.00	592.732	592.892	592.172	591.452	590.732	12.00

SUPERELEVATION TRANSITIONS							
STATION	INSIDE SHLD WIDTH	ELEVATIONS AT LOCATIONS					OUTSIDE SHLD WIDTH
		A	B	C	D	E	
413+63.58	8.00	589.080	589.240	588.520	587.800	587.080	12.00
413+75.00	8.00	589.066	589.192	588.472	587.752	587.032	12.00
414+00.00	8.00	589.038	589.089	588.369	587.649	586.929	12.00
414+03.58	8.00	589.040	589.080	588.360	587.640	586.920	12.00
414+25.00	BEGIN GORE GRADING INSIDE SHLD ENDS	589.000	588.280	587.560	586.840	12.00	
414+50.00		588.916	588.196	587.476	586.756	12.00	
414+75.00		588.824	588.104	587.384	586.664	12.00	
415+00.00		588.731	588.011	587.291	586.571	12.00	
415+24.00		588.632	587.912	587.192	586.472	12.00	
415+25.00		588.625	587.909	587.193	586.477	12.00	
415+50.00		588.461	587.845	587.229	586.613	12.00	
415+75.00		588.299	587.783	587.267	586.751	12.00	
415+84.00	588.239	587.759	587.279	586.799	12.00		
416+00.00	588.144	587.728	587.312	586.896	12.00		
416+02.00	588.135	587.727	587.319	586.911	12.00		



USER NAME = amkluver	DESIGNED - VLJ	REVISED -
DRAWN - AMK	REVISED -	
PLOT SCALE = 19.99996000 ' / in.	CHECKED - JMG	REVISED -
PLOT DATE = 6/23/2023	DATE - 6/26/23	REVISED -

**STATE OF ILLINOIS  
DEPARTMENT OF TRANSPORTATION**

**SUPERELEVATION TRANSITION DIAGRAMS**  
I-80

SCALE: NONE SHEET 3 OF 6 SHEETS STA. TO STA.

F.A.I. RTE.	SECTION	COUNTY	TOTAL SHEETS	SHEET NO.
I-80	FAI 80 21 STRUCTURE 6	WILL	898	88
				CONTRACT NO. 62R27
				ILLINOIS FED. AID PROJECT

MODEL: Ramp B  
 FILE NAME: p:\transystems\pwbentley.com\transystems\comp\pw-hosted\Documents\Projects\_2018\CH40140118002202-TransSystems\CAD\62R27\Struct\08-Cover and Super\01-SHT-SUPERELEV.DWG

**MULTIPLE LANE CONFIGURATION  
DEPARTURE**

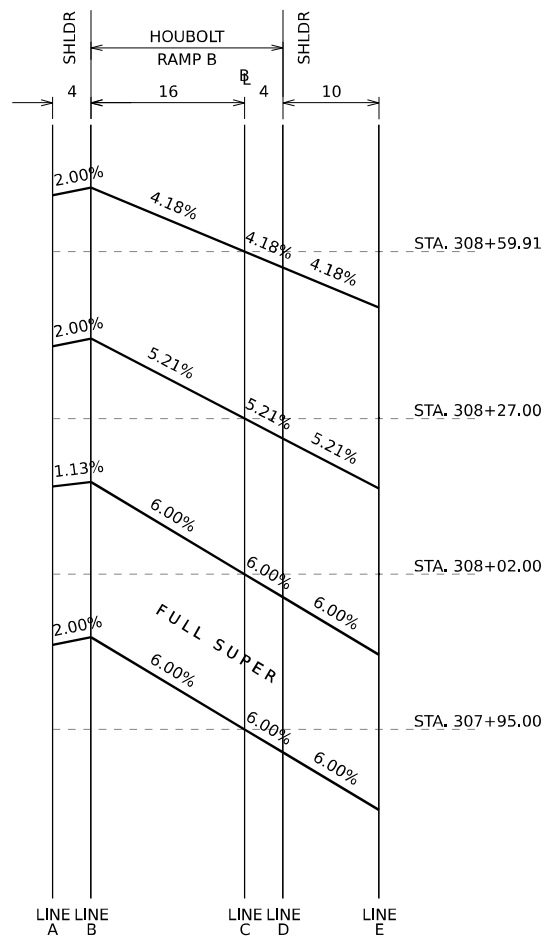

**SINGLE LANE CONFIGURATION  
DEPARTURE**

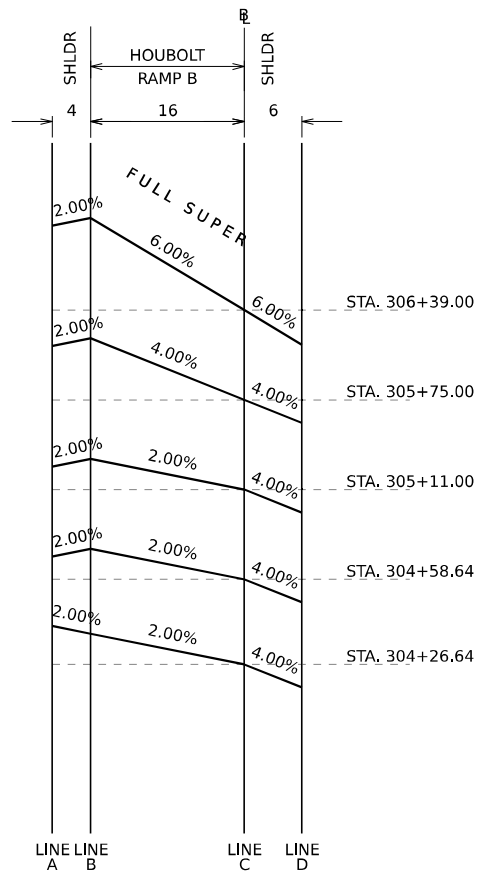

**S.E. TRANSITION SECTIONS HOUBOLT RAMP B**

STATION	INSIDE SHLD WIDTH	ELEVATIONS AT LOCATIONS				OUTSIDE SHLD WIDTH
		A	B	C	D	
304+26.64	4.00	599.990	599.910	599.590	599.350	6.00
304+50.00	4.00	599.764	599.801	599.481	599.241	6.00
304+58.64	4.00	599.681	599.761	599.441	599.201	6.00
304+75.00	4.00	599.606	599.686	599.366	599.126	6.00
305+00.00	4.00	599.491	599.571	599.251	599.011	6.00
305+11.00	4.00	599.440	599.520	599.200	598.960	6.00
305+25.00	4.00	599.437	599.517	599.127	598.887	6.01
305+50.00	4.00	599.391	599.471	598.956	598.715	6.02
305+75.00	4.00	599.296	599.376	598.736	598.495	6.03
306+00.00	4.00	599.151	599.231	598.466	598.158	6.45
306+25.00	4.00	598.956	599.036	598.146	597.764	6.87
306+39.00	4.00	598.825	598.905	597.945	597.519	7.10

STATION	INSIDE SHLD WIDTH	ELEVATIONS AT LOCATIONS					OUTSIDE SHLD WIDTH
		A	B	C	D	E	
307+95.00	4.00	595.813	595.893	594.933	594.696	594.107	9.82
308+00.00	4.00	595.735	595.790	594.830	594.577	593.985	9.86
308+02.00	4.00	595.703	595.748	594.788	594.528	593.936	9.87
308+25.00	4.00	595.081	595.159	594.315	594.014	593.487	9.99
308+27.00	4.00	595.027	595.107	594.273	593.969	593.448	10.00
308+50.00	4.00	594.437	594.517	593.799	593.465	593.016	10.00
308+59.91	4.00	594.210	594.290	593.595	593.255	592.837	10.00



USER NAME = amkluver	DESIGNED - VLJ	REVISED -
PLOT SCALE = 19.999996000 ' / in.	DRAWN - AMK	REVISED -
PLOT DATE = 6/23/2023	CHECKED - JMG	REVISED -
	DATE - 6/26/23	REVISED -

**STATE OF ILLINOIS  
DEPARTMENT OF TRANSPORTATION**

**SUPERELEVATION TRANSITION DIAGRAMS  
I-80**

SCALE: NONE SHEET 4 OF 6 SHEETS STA. TO STA.

F.A.I. RTE.	SECTION	COUNTY	TOTAL SHEETS	SHEET NO.
I-80	FAI 80 21 STRUCTURE 6	WILL	898	89
ILLINOIS FED. AID PROJECT			CONTRACT NO. 62R27	

MODEL: Ramp C  
 FILE NAME: p:\transystems\pwbentley.com\transystems\pwbentley-hosted\Documents\Projects\_2018\CI-401\401180022\02-TransSystems\CAD\62R27\Struct\08-Gore and Super\03-SE-T-SHT-SUPERELEVATION

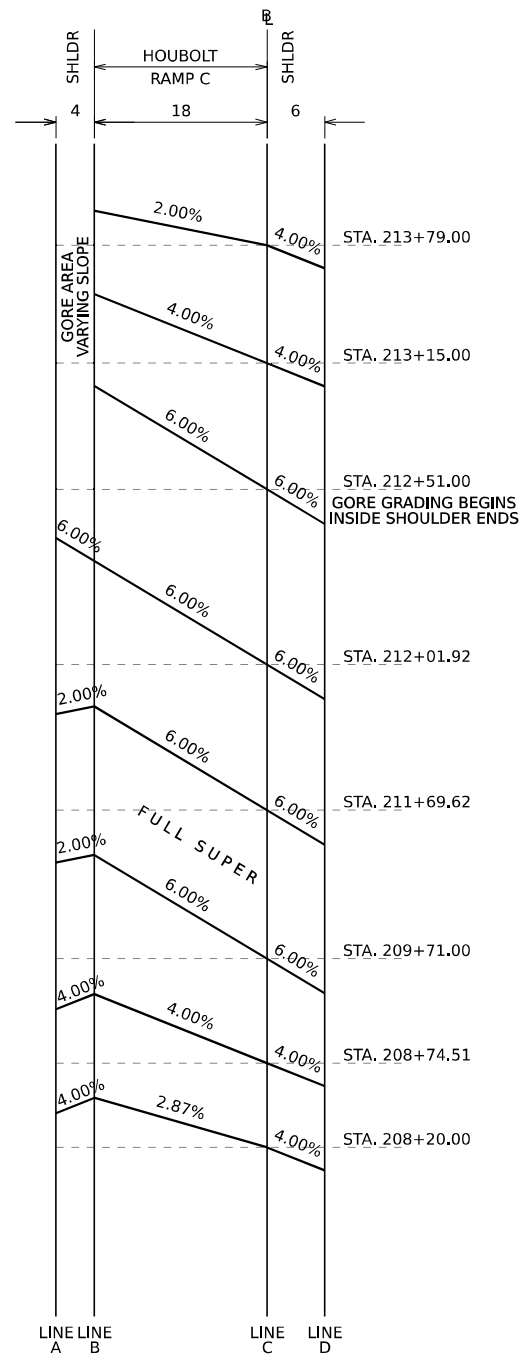

**S.E. TRANSITION SECTIONS HOUBOLT RAMP C**

SUPERELEVATION TRANSITIONS					
STATION	ELEVATIONS AT LOCATIONS				LANE WIDTH
	A	B	C	D	
208+20.00	593.750	593.910	593.214	592.974	24.24
208+25.00	593.907	594.067	593.352	593.112	24.05
208+50.00	594.687	594.847	594.040	593.800	23.11
208+74.51	595.426	595.586	594.698	594.458	22.19
208+75.00	595.439	595.599	594.710	594.469	22.17
209+00.00	596.133	596.272	595.324	595.052	20.93
209+25.00	596.757	596.875	595.881	595.578	19.69
209+50.00	597.310	597.407	596.380	596.046	18.46
209+71.00	597.720	597.800	596.755	596.395	17.42

SUPERELEVATION TRANSITIONS				
STATION	ELEVATIONS AT LOCATIONS			
	A	B	C	D
211+69.62	599.374	599.454	598.494	598.134
211+75.00	599.426	599.479	598.519	598.159
212+00.00	599.664	599.594	598.634	598.274
212+01.92	599.680	599.600	598.640	598.280
212+25.00		599.778	598.818	598.458
212+50.00		599.951	598.991	598.631
212+51.00		599.958	598.998	598.638
212+75.00		600.109	599.269	598.954
213+00.00		600.253	599.538	599.270
213+15.00		600.331	599.691	599.451
213+25.00		600.381	599.791	599.551
213+50.00		600.506	600.041	599.801
213+75.00		600.631	600.291	600.051
213+79.00		600.651	600.331	600.091



USER NAME = amkluver	DESIGNED - VLJ	REVISED -
PLOT SCALE = 19.99996000 ' / in.	DRAWN - AMK	REVISED -
PLOT DATE = 6/23/2023	CHECKED - JMG	REVISED -
	DATE - 6/26/23	REVISED -

**STATE OF ILLINOIS**  
**DEPARTMENT OF TRANSPORTATION**

**SUPERELEVATION TRANSITION DIAGRAMS**  
**I-80**  
 SCALE: NONE SHEET 5 OF 6 SHEETS STA. TO STA.

F.A.I. RTE.	SECTION	COUNTY	TOTAL SHEETS	SHEET NO.
I-80	FAI 80 21 STRUCTURE 6	WILL	898	90
CONTRACT NO. 62R27				
ILLINOIS FED. AID PROJECT				

MODEL: Ramp\_D  
 FILE NAME: p:\transystems\pwbentley.com\transystems\comp\pwbentley.com\transystems\CAD\62R27\Struct\08-Gore and Super\05-SE-T-SHT-SUPERELEVATION.DWG

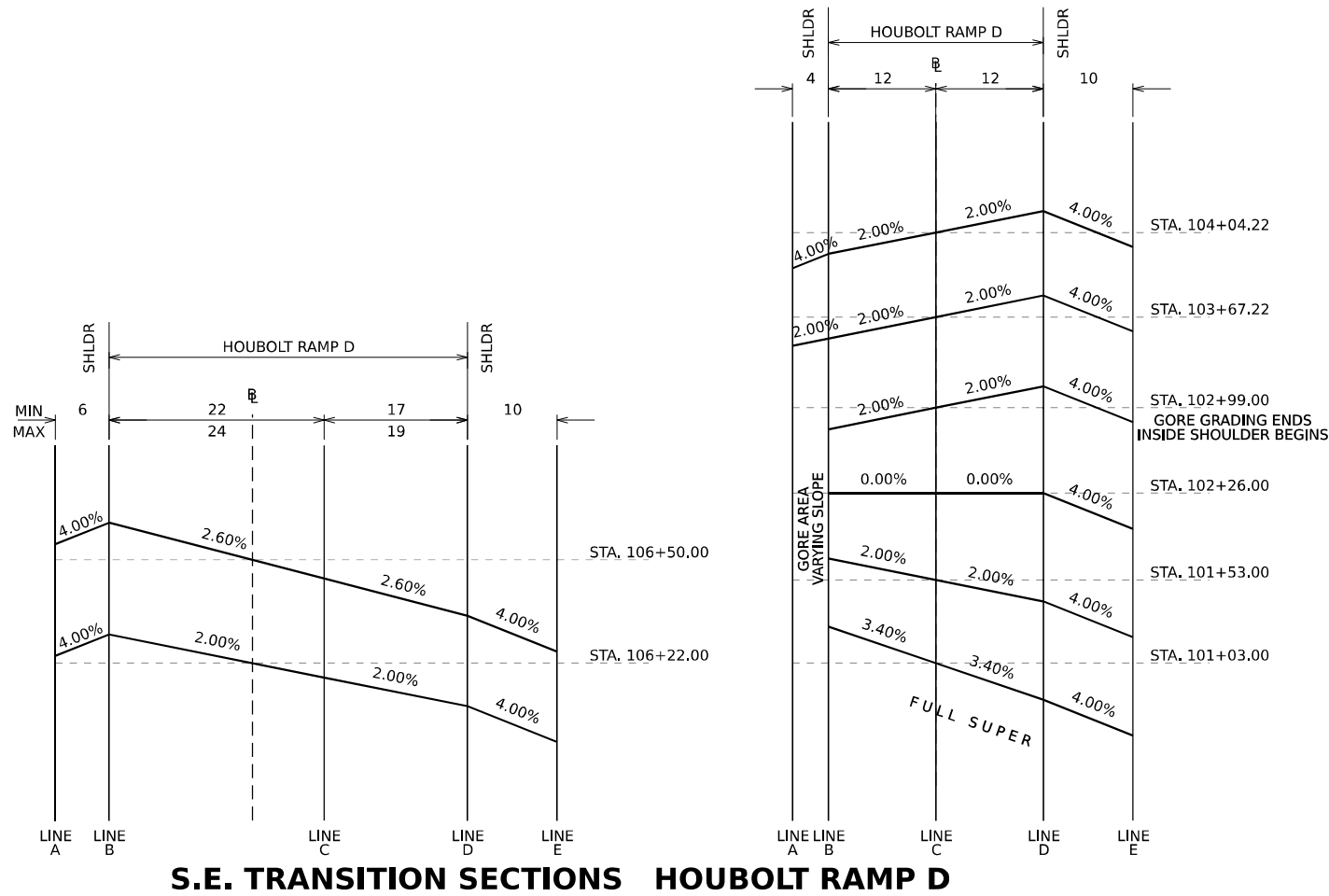

STATION	SUPERELEVATION TRANSITIONS				
	ELEVATIONS AT LOCATIONS				
	A	B	C	D	E
101+03.00		591.183	591.591	591.999	591.599
101+25.00		591.283	591.617	591.952	591.552
101+50.00		591.378	591.628	591.878	591.478
101+53.00	END GORE GRADING INSIDE SHLD BEGINS	591.388	591.628	591.868	591.468
101+75.00		591.455	591.622	591.790	591.390
102+00.00		591.514	591.600	591.685	591.285
102+25.00		591.553	591.556	591.560	591.160
102+26.00		591.554	591.554	591.554	591.154
102+50.00		591.569	591.490	591.411	591.011
102+75.00		591.562	591.401	591.240	590.840
102+99.00		591.529	591.289	591.049	590.649
103+00.00		591.528	591.288	591.048	590.648
103+25.00		591.605	591.365	591.125	590.725
103+50.00		591.703	591.463	591.223	590.823
103+67.22		591.787	591.547	591.307	590.907
103+75.00		591.840	591.810	591.570	590.930
104+00.00		591.779	591.912	591.672	591.432
104+04.22		591.770	591.930	591.690	591.450

STATION	SUPERELEVATION TRANSITIONS				
	ELEVATIONS AT LOCATIONS				
	A	B	C	D	E
106+22.00	592.248	592.475	592.028	591.677	591.269
106+25.00	592.249	592.477	592.012	591.647	591.238
106+50.00	592.247	592.487	591.862	591.371	590.961



USER NAME = amkluver	DESIGNED - VLJ	REVISED -
PLOT SCALE = 19.999996000 ' / in.	DRAWN - AMK	REVISED -
PLOT DATE = 6/23/2023	CHECKED - JMG	REVISED -
	DATE - 6/26/23	REVISED -

**STATE OF ILLINOIS**  
**DEPARTMENT OF TRANSPORTATION**

**SUPERELEVATION TRANSITION DIAGRAMS**  
**I-80**

SCALE: NONE SHEET 6 OF 6 SHEETS STA. TO STA.

F.A.I. RTE.	SECTION	COUNTY	TOTAL SHEETS	SHEET NO.
I-80	FAI 80 21 STRUCTURE 6	WILL	898	91
			CONTRACT NO. 62R27	
		ILLINOIS	FED. AID PROJECT	

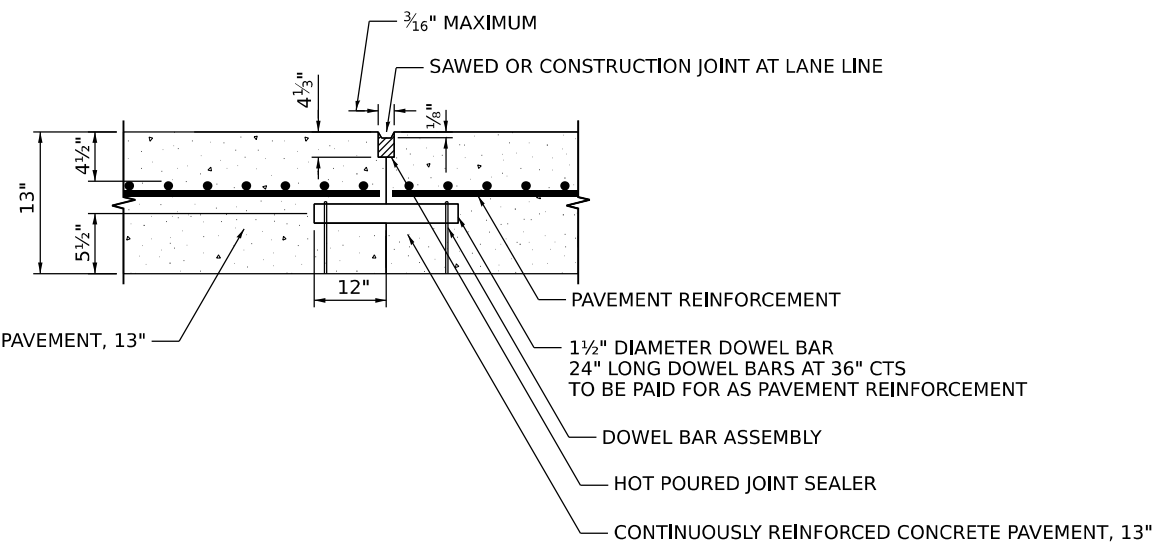

CONTINUOUSLY REINFORCED CONCRETE PAVEMENT, 13"

PAVEMENT REINFORCEMENT

1 1/2" DIAMETER DOWEL BAR  
24" LONG DOWEL BARS AT 36" CTS  
TO BE PAID FOR AS PAVEMENT REINFORCEMENT

DOWEL BAR ASSEMBLY

HOT Poured JOINT SEALER

CONTINUOUSLY REINFORCED CONCRETE PAVEMENT, 13"

### LONGITUDINAL DOWEL JOINT

MODEL: Detail Sheet  
 FILE NAME: p:\transystems\pw\beutby.com\transystems\comp\pw\_hosted\Documents\Projects\_2018\CI-401\401.180022\02-TransSystems\CAD\62R27\Streets\08-Cure and Super\0162R27-SHT-JOINTING-DETAIL.dgn

**TRANSYSTEMS**

USER NAME = amkluver	DESIGNED - VLJ	REVISED -
PLOT SCALE = 0.166666' / in.	DRAWN - AMK	REVISED -
PLOT DATE = 6/23/2023	CHECKED - JMG	REVISED -
	DATE - 6/26/23	REVISED -

**STATE OF ILLINOIS  
DEPARTMENT OF TRANSPORTATION**

**JOINTING DETAILS**

SCALE: NONE SHEET 1 OF 4 SHEETS STA. TO STA.

F.A.I. RTE.	SECTION	COUNTY	TOTAL SHEETS	SHEET NO.
I-80	FAI 80 21 STRUCTURE 6	WILL	898	92
CONTRACT NO. 62R27				
ILLINOIS FED. AID PROJECT				

MODEL: Detail Sheet 2  
 FILE NAME: p:\projects\transystems\pavement\transystems\CAD\2022\02-27\transystems\CAD\2022\02-27\SHOULDER-DETAIL.dgn  
 PROJECT: 2018-01-01\401180022\02-27\transystems\CAD\2022\02-27\SHOULDER-DETAIL.dgn  
 USER: amkljuver

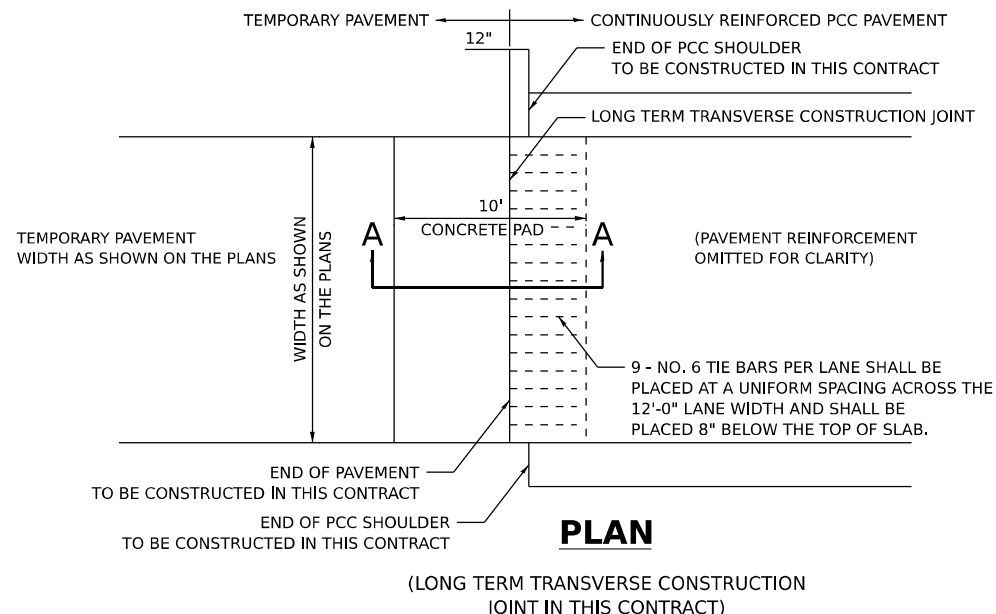

**PLAN**

(LONG TERM TRANSVERSE CONSTRUCTION JOINT IN THIS CONTRACT)

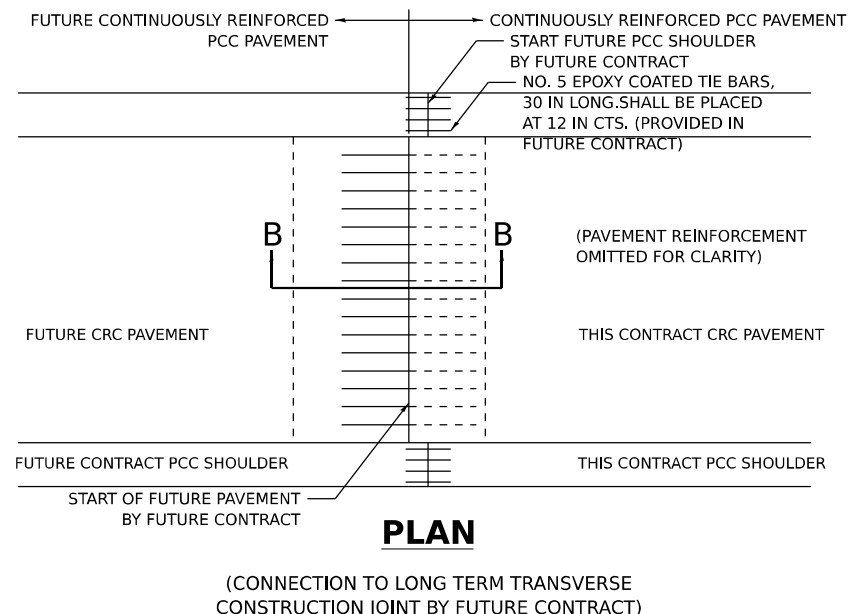

**PLAN**

(CONNECTION TO LONG TERM TRANSVERSE CONSTRUCTION JOINT BY FUTURE CONTRACT)

**NOTES:**

- THIS DETAIL SHOWS THE TERMINATION OF PROPOSED CRC PAVEMENT THAT WILL BE EXTENDED BY FUTURE CONSTRUCTION.
- BAR SPLICER ASSEMBLIES SHALL BE OF AN IDOT APPROVED TYPE AND SHALL DEVELOP IN TENSION AT LEAST 125 PERCENT OF THE YIELD STRENGTH OF THE LAPPED REINFORCEMENT BARS.
- BAR SPLICERS SHALL BE OF THE "COUPLER" TYPE, AND SHALL NOT HAVE FLANGES.
- SPLICER RODS SHALL BE OF MINIMUM 60KSI YIELD STRENGTH, THREADED OR COILED FULL LENGTH.
- ALL REINFORCEMENT BARS SHALL BE LAPPED AND TIED TO THE SPLICER RODS OR DOWEL BARS.
- BAR SPLICER ASSEMBLIES SHALL BE EPOXY COATED ACCORDING TO THE REQUIREMENTS FOR REINFORCEMENT BARS.
- OTHER SYSTEMS OF SIMILAR DESIGN MAY BE SUBMITTED TO THE ENGINEER FOR APPROVAL. APPROVAL SHALL BE BASED ON CERTIFIED TEST RESULTS FROM AN APPROVED TESTING LABORATORY THAT THE PROPOSED BAR SPLICER ASSEMBLY SATISFIES THE FOLLOWING REQUIREMENTS:
  - A. MINIMUM CAPACITY (TENSION IN KSI) =  $1.25 \times f_y \times A(t)$
  - B. MINIMUM \*PULL-OUT STRENGTH (TENSION IN KSI) =  $1.25 \times f_s(\text{ALLOW}) \times A(t)$
 WHERE:  
 $f_y$  = YIELD STRENGTH OF LAPPED REINFORCEMENT BARS IN KSI  
 $f_s(\text{ALLOW})$  = ALLOWABLE TENSILE STRESS IN LAPPED REINFORCEMENT BARS IN KSI (SERVICE LOAD)  
 $A(t)$  = TENSILE STRESS AREA OF LAPPED REINFORCEMENT BARS (IN<sup>2</sup>).  
 \* = 28 DAY CONCRETE

BAR SIZE TO BE SPLICED	SPLICER ROD OR DOWEL BAR LENGTH	STRENGTH REQUIREMENTS	
		MIN. CAPACITY (KIPS) TENSION	MIN. PULL-OUT STRENGTH (KIPS) TENSION
#5	2'-0"	23.0	9.2
#6	2'-7"	33.1	13.3
#7	3'-5"	45.1	18.0
#8	4'-6"	58.9	23.6
#9	5'-9"	75.0	30.0

- BAR SPLICER ASSEMBLIES SHALL BE ACCORDING TO SECTION 508 OF THE STANDARD SPECIFICATIONS, EXCEPT AS NOTED.
- REINFORCEMENT SHALL NOT BE PAID FOR SEPARATELY BUT INCLUDED IN THE COST OF CONTINUOUSLY REINFORCED PORTLAND CEMENT PAVEMENT, OF THE THICKNESS SPECIFIED.
- CONNECTION TO LONG TERM TRANSVERSE CONSTRUCTION JOINT WORK INCLUDES THE INSTALLATION OF THE BAR SPLICERS. PAYMENT FOR THIS WORK WILL BE INCLUDED IN THE COST OF CONTINUOUSLY REINFORCED PORTLAND CEMENT CONCRETE PAVEMENT OF THE THICKNESS SPECIFIED. TIE BARS TO BE DRILLED AND GROUTED SHALL NOT BE PAID FOR SEPARATELY BUT INCLUDED IN THE COST OF PORTLAND CEMENT CONCRETE SHOULDERS, OF THE THICKNESS SPECIFIED.
- SEE STANDARD 421001-03 FOR DETAILS OF PAVEMENT REINFORCEMENT.

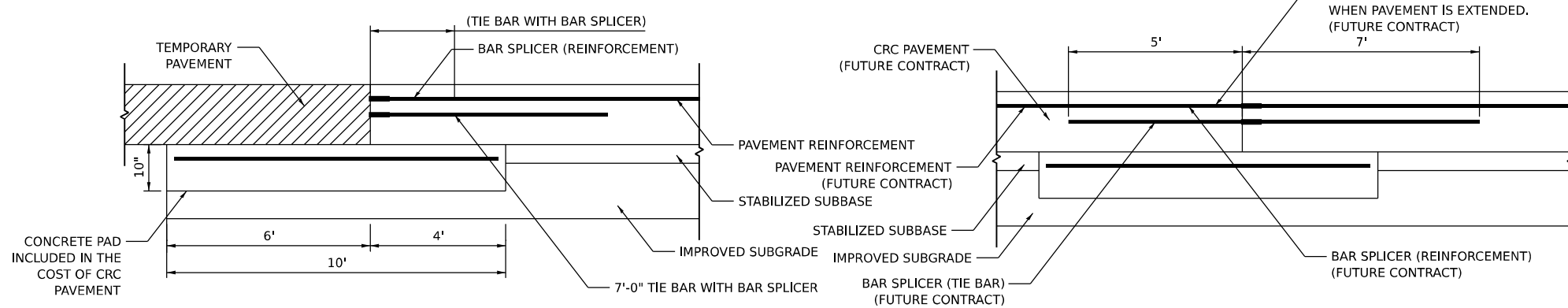

**LONG TERM TRANSVERSE CONSTRUCTION JOINT SECTION A-A**

**LONG TERM TRANSVERSE CONSTRUCTION JOINT SECTION B-B**

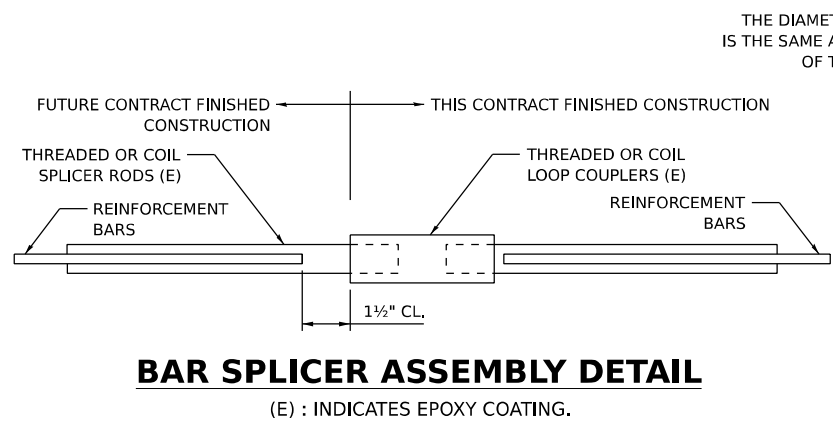

**BAR SPLICER ASSEMBLY DETAIL**

(E) : INDICATES EPOXY COATING.

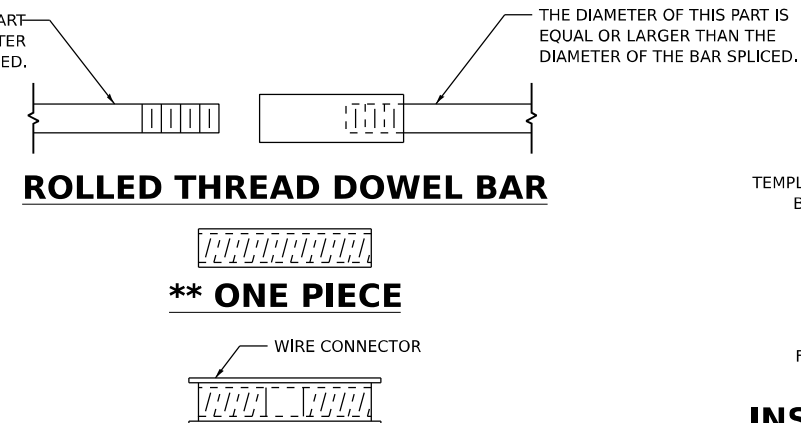

**WELDED SECTIONS BAR SPLICER ASSEMBLY ALTERNATIVES**

\*\* HEAVY HEX NUTS CONFORMING TO ASTM A 563M, GRADE C, D OR DH MAY BE USED.

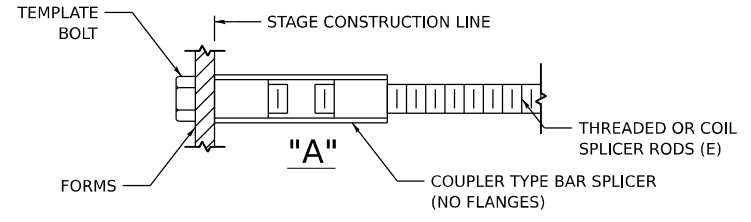

**INSTALLATION AND SETTING METHODS**

"A" : SET BAR SPLICER ASSEMBLY BY MEANS OF A TEMPLATE BOLT.  
 (E) : INDICATES EPOXY COATING.



USER NAME = amkljuver	DESIGNED - VLJ	REVISED -
PLOT SCALE = 0.1666667 / in.	DRAWN - AMK	REVISED -
PLOT DATE = 6/23/2023	CHECKED - JMG	REVISED -
	DATE - 6/26/23	REVISED -

**STATE OF ILLINOIS DEPARTMENT OF TRANSPORTATION**

<b>JOINING DETAILS</b>			
SCALE: NONE	SHEET 2	OF 4 SHEETS	STA. TO STA.

F.A.I. RTE.	SECTION	COUNTY	TOTAL SHEETS	SHEET NO.
I-80	FAI 80 21 STRUCTURE 6	WILL	898	93
CONTRACT NO. 62R27				
ILLINOIS FED. AID PROJECT				





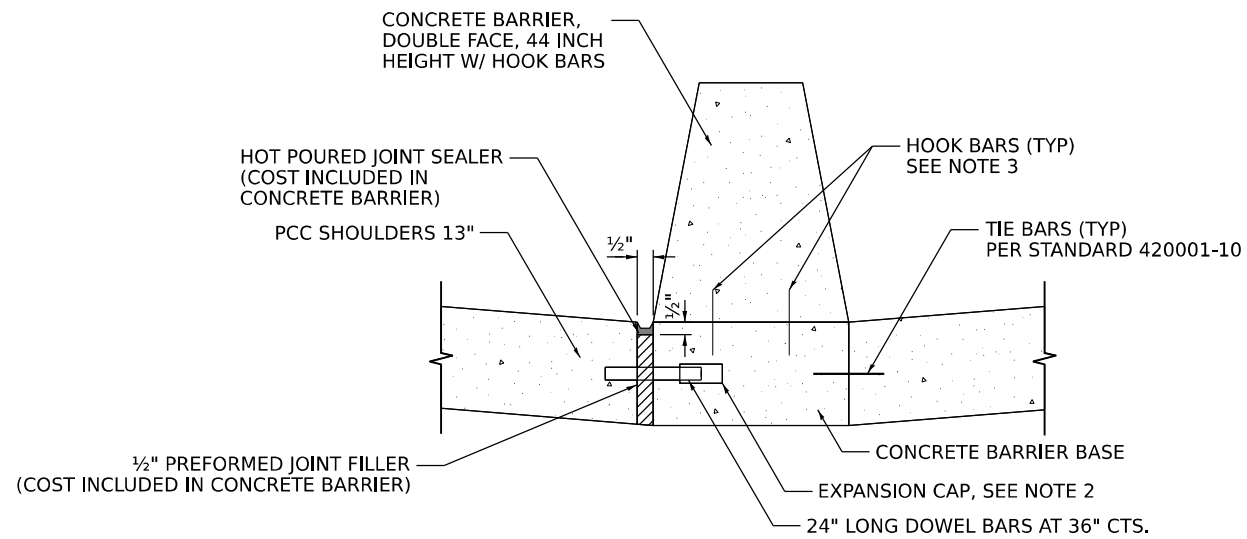

**LONGITUDINAL JOINT AT  
MEDIAN BARRIER WITH DOWEL**

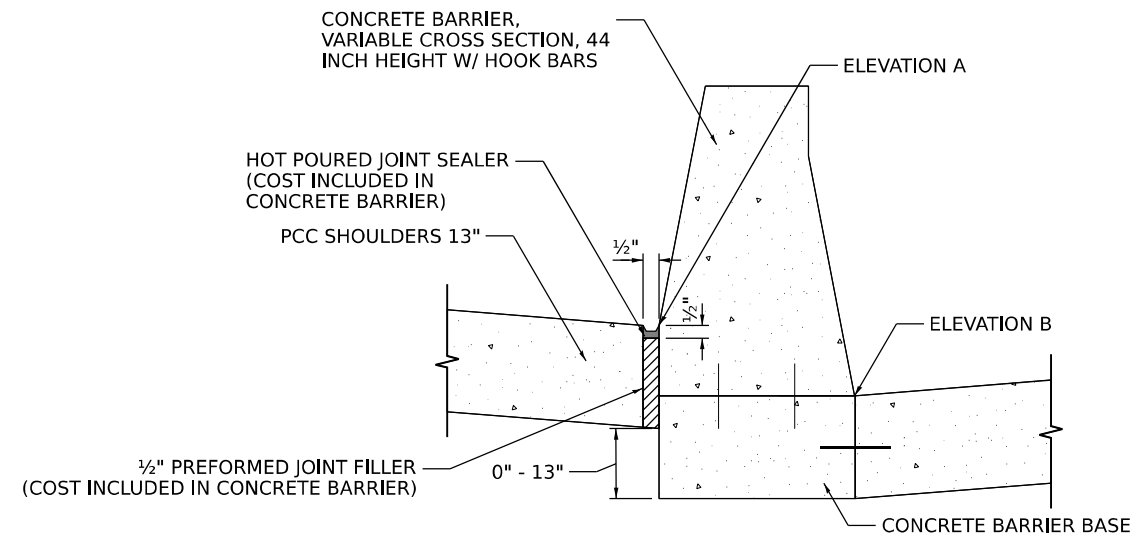

**LONGITUDINAL JOINT AT VARIABLE  
HEIGHT MEDIAN BARRIER WITHOUT DOWEL**

TO BE USED WHEN ELEVATION A IS 0 TO 13" HIGHER THAN ELEVATION B

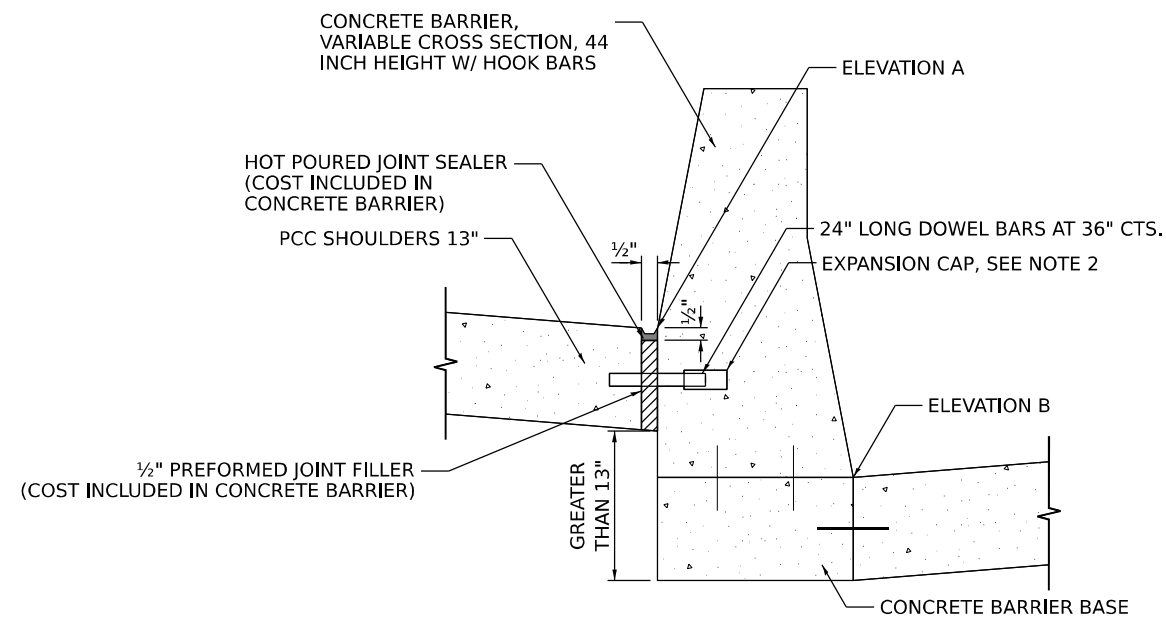

**LONGITUDINAL JOINT AT VARIABLE  
HEIGHT MEDIAN BARRIER WITH DOWEL**

TO BE USED WHEN ELEVATION A IS GREATER THAN 13" HIGHER THAN ELEVATION B

**NOTES:**

- SEE STANDARD 420001-10 FOR OTHER DETAILS.
- EXPANSION CAPS SHALL BE INSTALLED ON THE EXPOSED END OF EACH DOWEL BAR ONCE THE HEADER HAS BEEN REMOVED AND THE JOINT FILLER MATERIAL HAS BEEN INSTALLED.
- NO. 6 (NO.19) HOOK BARS AT 30 (760) CTS. (STAGGERED SIDE TO SIDE).

MODEL: Detail Sheet 4  
FILE NAME: p:\transystems\pwbentby\comtransystems\comp-pw-headers\Documents\Projects\_2018\CH401\401180022\02-TransSystems\CAD\62R27\Struct\08-Cover and Super\032R27-SHT-JOINTING-DETAIL.dgn

**TRANSYSTEMS**

USER NAME = amkluver	DESIGNED - VLJ	REVISED -
PLOT SCALE = 0.166666' / in.	DRAWN - AMK	REVISED -
PLOT DATE = 6/23/2023	CHECKED - JMG	REVISED -
	DATE - 6/26/23	REVISED -

**STATE OF ILLINOIS  
DEPARTMENT OF TRANSPORTATION**

**JOINTING DETAILS**

SCALE: NONE SHEET 4 OF 4 SHEETS STA. TO STA.

F.A.I. RTE.	SECTION	COUNTY	TOTAL SHEETS	SHEET NO.
I-80	FAI 80 21 STRUCTURE 6	WILL	898	95
CONTRACT NO. 62R27				
ILLINOIS FED. AID PROJECT				

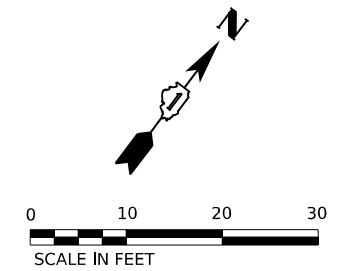

MATCHLINE STA. 430+60.00  
SEE SHEET NO. 97

**NOTES:**

- SEE JOINTING AND SUPERELEVATION PLAN SHEETS FOR GEOMETRIC AND JOINT INFORMATION

MODEL: GGD-01  
FILE NAME: p:\transystems\ppl\transystems\comp\ppl\hosted\Documents\Projects\_2018\CI-401\401180022\02-Transystems\CAD\2022\Finals\08-Gore and Super\052R2+SHT-GORE-DETAIL.dgn



USER NAME = amkluver	DESIGNED - VLJ	REVISED -
DRAWN - AMK	REVISED -	
PLOT SCALE = 19.99996000" / in.	CHECKED - JMG	REVISED -
PLOT DATE = 6/23/2023	DATE - 6/26/23	REVISED -

**STATE OF ILLINOIS  
DEPARTMENT OF TRANSPORTATION**

**GORE GRADING DETAILS  
HUBOLT RAMP A AND WB I-80 (1 OF 2)**

SCALE: 1"=10'      SHEET 1 OF 8 SHEETS      STA. TO STA.

F.A.I. RTE.	SECTION	COUNTY	TOTAL SHEETS	SHEET NO.
I-80	FAI 80 21 STRUCTURE 6	WILL	898	96
CONTRACT NO. 62R27				
ILLINOIS		FED. AID PROJECT		

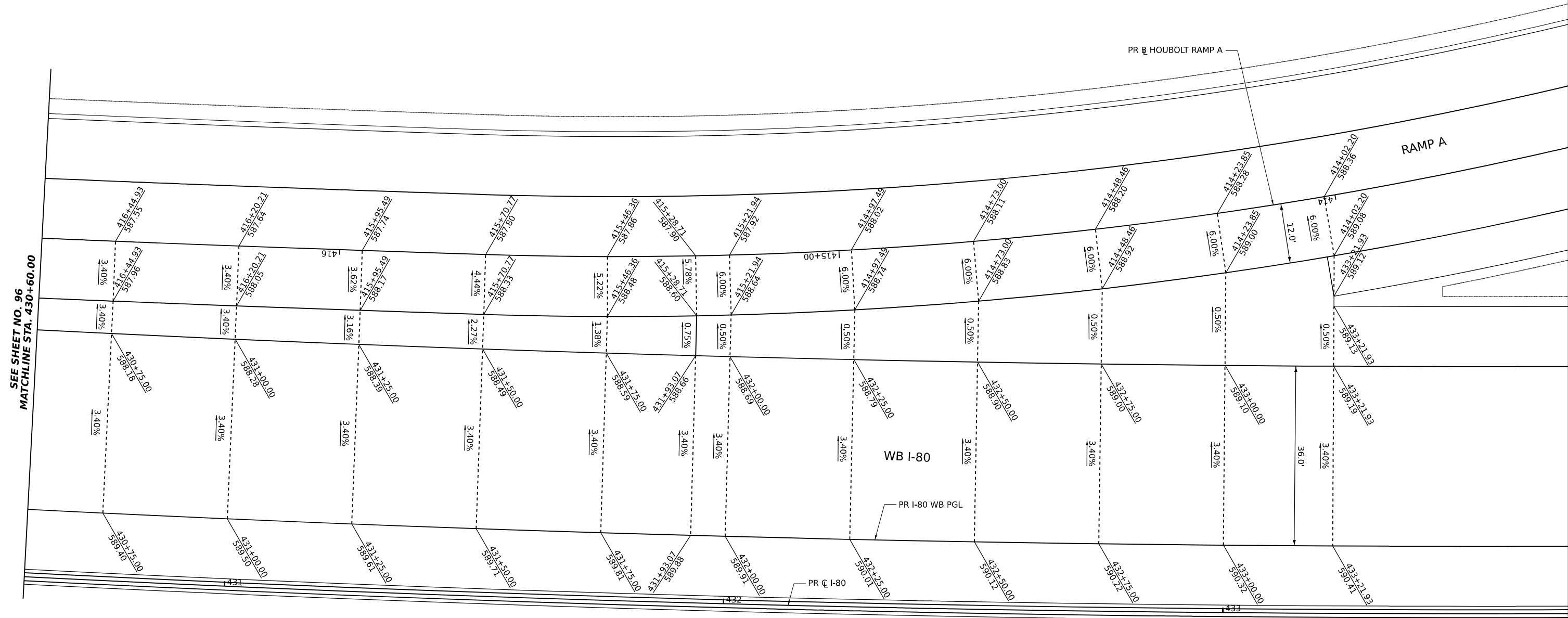
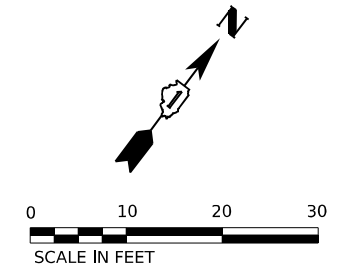

SEE SHEET NO. 96  
MATCHLINE STA. 430+60.00

**NOTES:**

- SEE JOINTING AND SUPERELEVATION PLAN SHEETS FOR GEOMETRIC AND JOINT INFORMATION

MODEL: GGD-02  
FILE NAME: p:\transystems\ppl\ben\by.com\transystems\comp\pw\_1\res\doc\Documents\Projects\_2018\CH401\401180022\02-TransSystems\CAD\62827\Bnets\08-Gore and Super\0152827-SHT-GORE-DETAL.dgn

**TRANSYSTEMS**

USER NAME = amkluver	DESIGNED - VLJ	REVISED -
PLOT SCALE = 19.99996000" / in.	DRAWN - AMK	REVISED -
PLOT DATE = 6/23/2023	CHECKED - JMG	REVISED -
	DATE - 6/26/23	REVISED -

**STATE OF ILLINOIS  
DEPARTMENT OF TRANSPORTATION**

**GORE GRADING DETAILS  
HOUBOLT RAMP A AND WB I-80 (2 OF 2)**

SCALE: 1"=10' SHEET 2 OF 8 SHEETS STA. TO STA.

F.A.I. RTE.	SECTION	COUNTY	TOTAL SHEETS	SHEET NO.
I-80	FAI 80 21 STRUCTURE 6	WILL	898	97
			CONTRACT NO. 62R27	
		ILLINOIS FED. AID PROJECT		

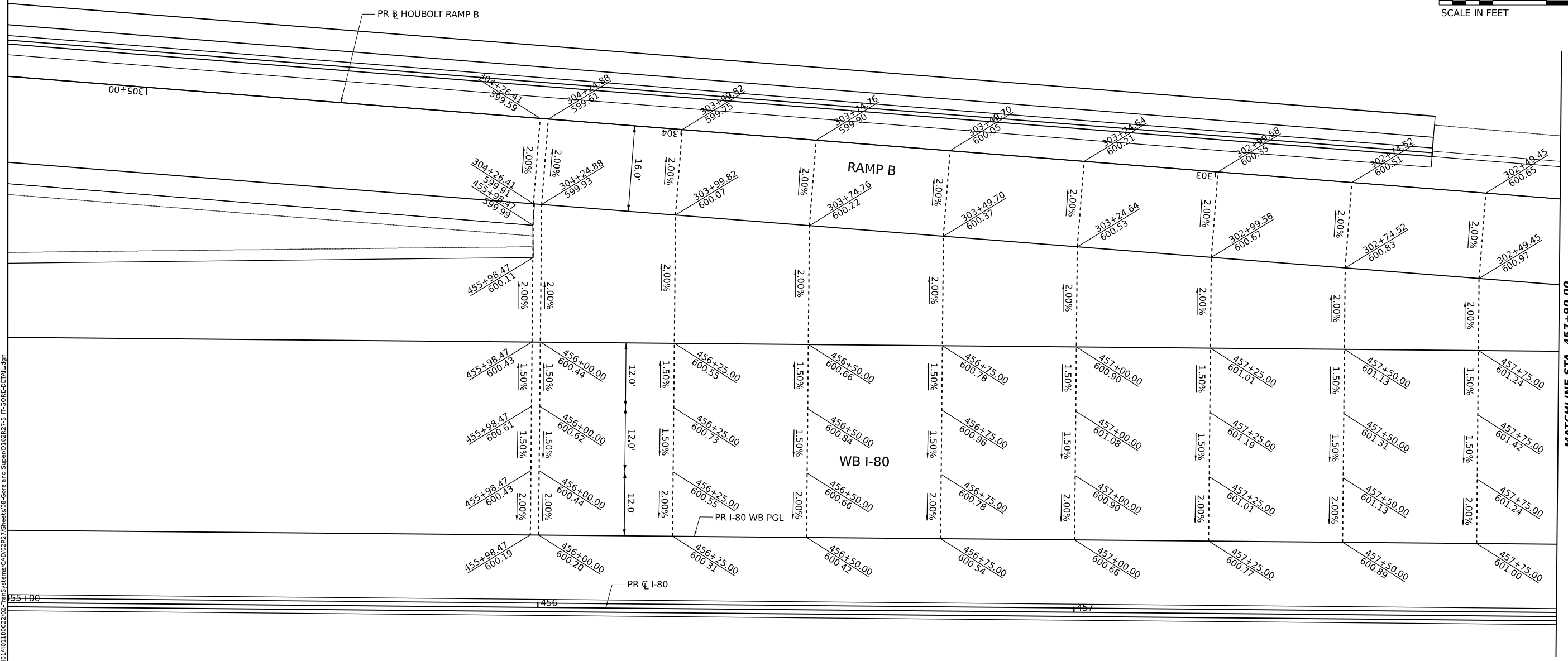
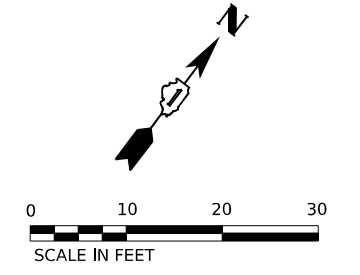

MATCHLINE STA. 457+90.00  
SEE SHEET NO. 99

**NOTES:**

- SEE JOINTING AND SUPERELEVATION PLAN SHEETS FOR GEOMETRIC AND JOINT INFORMATION

MODEL: GGD-03  
FILE NAME: p:\transystems\pww\transystems\comp\pw-hosted\Documents\Projects\_2018\CI-401\401180022\02-TransSystemsCAD\62R27\Struct\08-Gore and Super\0152R27-SHT-GORE-DETAIL.dgn



USER NAME = amkluver	DESIGNED - VLJ	REVISED -
PLOT SCALE = 19.99996000 1/ in.	DRAWN - AMK	REVISED -
PLOT DATE = 6/23/2023	CHECKED - JMG	REVISED -
	DATE - 6/26/23	REVISED -

**STATE OF ILLINOIS  
DEPARTMENT OF TRANSPORTATION**

**GORE GRADING DETAILS  
HOUBOLT RAMP B AND WB I-80 (1 OF 2)**

SCALE: 1"=10'    SHEET 3 OF 8 SHEETS    STA. TO STA.

F.A.I. RTE.	SECTION	COUNTY	TOTAL SHEETS	SHEET NO.
	FAI 80 21 STRUCTURE 6	WILL	898	98
CONTRACT NO. 62R27				
ILLINOIS FED. AID PROJECT				

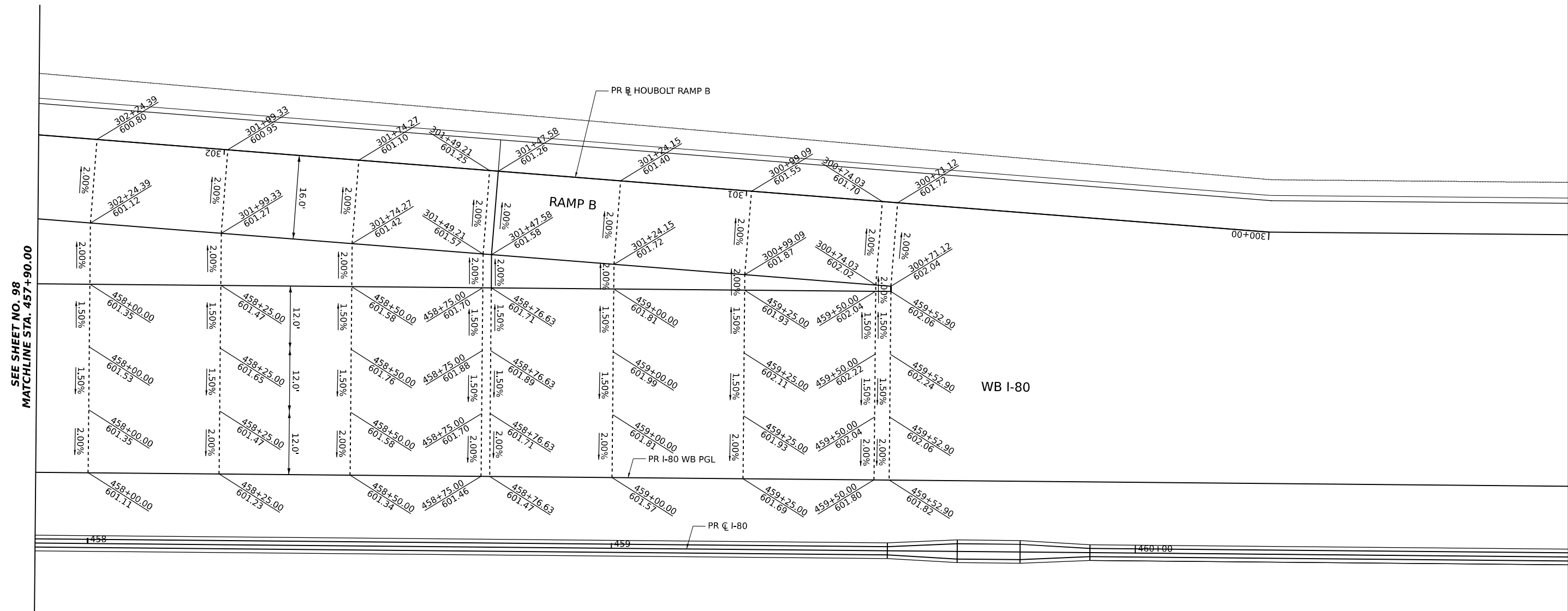
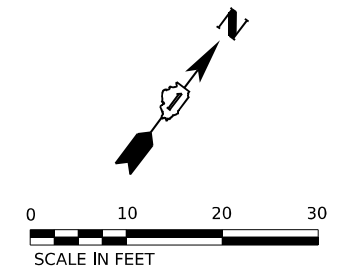

SEE SHEET NO. 98  
MATCHLINE STA. 457+90.00

**NOTES:**

1. SEE JOINTING AND SUPERELEVATION PLAN SHEETS FOR GEOMETRIC AND JOINT INFORMATION

MODEL: GGD-04  
 FILE NAME: p:\transystems\p\transystems\comp\pw-hosted\Documents\Projects\_2018\CI-401\401180022\02-TransSystems-CAD\62R27\Struct\08-Gore and Super\015821-SHT-GORE-DETAIL.dgn



USER NAME = amkluver	DESIGNED - VLJ	REVISED -
PLOT SCALE = 19.999996000 ' / in.	DRAWN - AMK	REVISED -
PLOT DATE = 6/23/2023	CHECKED - JMG	REVISED -
	DATE - 6/26/23	REVISED -

**STATE OF ILLINOIS  
DEPARTMENT OF TRANSPORTATION**

**GORE GRADING DETAILS  
HOUBOLT RAMP B AND WB I-80 (2 OF 2)**

F.A.I. RTE.	SECTION	COUNTY	TOTAL SHEETS	SHEET NO.
I-80	FAI 80 21 STRUCTURE 6	WILL	898	99
CONTRACT NO. 62R27				
		ILLINOIS	FED. AID PROJECT	

SCALE: 1"=10'      SHEET 4    OF 8    SHEETS    STA.                    TO STA.

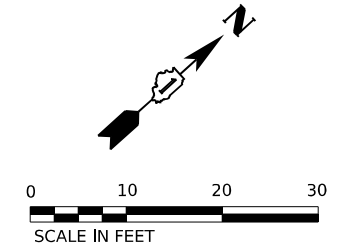

MODEL: GGD-05  
 FILE NAME: p:\transystems\comp\pwr\housed\Documents\Projects\_2018\CH401401180022\02-TransSystemsCAD\62R27\Struct\08-Gore and Super\0152R27-SHT-GORE-DETAIL.dgn

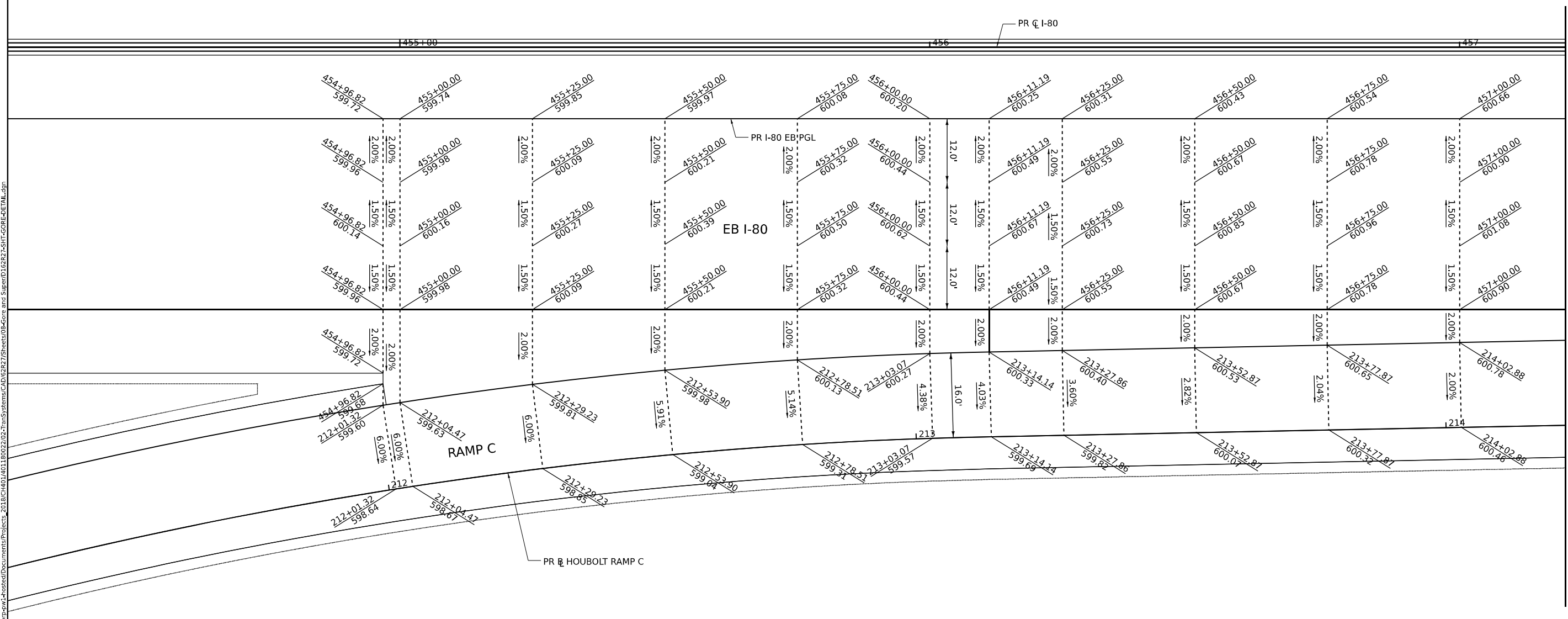

MATCHLINE STA. 457+20.00  
 SEE SHEET NO. 101

**NOTES:**

- SEE JOINTING AND SUPERELEVATION PLAN SHEETS FOR GEOMETRIC AND JOINT INFORMATION



USER NAME = amkluver	DESIGNED - VLJ	REVISED -
DRAWN - AMK	REVISED -	
PLOT SCALE = 19.99996000" / in.	CHECKED - JMG	REVISED -
PLOT DATE = 6/23/2023	DATE - 6/26/23	REVISED -

**STATE OF ILLINOIS**  
**DEPARTMENT OF TRANSPORTATION**

**GORE GRADING DETAILS**  
**HOUBOLT RAMP C AND EB I-80 (1 OF 2)**

SCALE: 1"=10'    SHEET 5 OF 8 SHEETS    STA. TO STA.

F.A.I. RTE.	SECTION	COUNTY	TOTAL SHEETS	SHEET NO.
I-80	FAI 80 21 STRUCTURE 6	WILL	898	100
			CONTRACT NO. 62R27	
		ILLINOIS	FED. AID PROJECT	