

---

---

**Abbreviated Structural Geotechnical Report**

**Proposed 6' x 3' Culvert Under I-80**

**IDOT Job Number P-91-185-09**

**Proposed SN: NA**

**Existing SN: NA**

**Contract No.: 62R29**

**New Lenox, Will County, IL**

---

---

**Prepared for:**

**EXP US Services Inc.  
205 North Michigan Avenue, Suite 3600  
Chicago, IL 60601-5924**

**Prepared by:**

**Geo Services, Inc.  
805 Amherst Court  
Suite 204  
Naperville, Illinois 60565  
(630) 305-9186**



**JOB NO. 20012**

**April 04, 2023**



<b>Original Report Date:</b> <u>10/17/2022</u>	<b>Proposed SN:</b> <u>NA</u>	<b>Route:</b> <u>IL-80</u>
<b>Revised Date:</b> <u>04/04/2023</u>	<b>Existing SN:</b> <u>NA</u>	<b>Section:</b> _____
<b>Geotechnical Engineer:</b> <u>Geo Services Inc,</u>		<b>County:</b> <u>Will</u>
<b>Structural Engineer:</b> <u>EXP US Services Inc</u>		<b>Contract:</b> <u>62R29</u>

**Indicate the proposed structure type, substructure types, and foundation locations (attach plan and elevation drawing):** The proposed structure is a 6' x 3' box culvert that goes under I-80, replacing the existing 36" pipe culvert. The preliminary plan and profile are showing the proposed culvert is about 146 feet and skewed 2°. A 20'-5" culvert drop box is attached at the west end of the proposed culvert to transfer the water from the proposed drainage ditch to the proposed culvert. The preliminary design drawings are attached.

**Discuss the existing boring data, existing plans foundation information, new subsurface exploration and need for any additional exploration to be provided with SGR Technical Memo (attach all data and subsurface profile plot):** Three borings were drilled in December 2021, February and March 2022 for subsurface exploration. All borings had 12" of top soil and asphalt at the top of the borings. Boring CB-004 was drilled near the north end of the proposed culvert. Boring CB-004 is consists of stiff to hard clay loam from 1 feet to a termination of boring at 20 feet below the surface. Boring CB-005 was drilled close to the middle of the proposed culvert. CB-005 is consists of stiff to very stiff clay loam from 1 feet to a termination of boring at 20 feet below the surface. Boring CB-006 was drilled close to the south end of the proposed culvert. CB-006 indicates about 1 to 10.5 feet of very stiff to hard clay loam, followed by very stiff clay to a termination of boring at 20 feet below the surface.

**Provide the location and maximum height of any new soil fill or magnitude of footing bearing pressure. Estimate the amount and time of the expected settlement. Indicate if further testing, analysis, and/or ground improvement/treatment is necessary:** The proposed plan and profile are showing 1' of fill across the length of the culvert is expected. No settlement issues are anticipated.

**Identify any new cuts or fill slope angles and heights. Estimate the factor of safety against slope failure. Indicate if further testing, analysis or ground improvement/treatment is necessary:** The proposed plan and profile are showing 1' of fill across the length of the culvert is expected. No settlement concerns are anticipated.

**Indicate at each substructure, the 100-year and 200-year total scour depths in the Hydraulics report, the non-granular scour depth reduction, the proposed ground surface, and the recommended foundation design scour elevations:** No longer required for culverts as per ABD memo 14.2.

**Determining the seismic soil site class, the seismic performance zone, the 0.2 and 1.0 second design spectral accelerations and indicate if that the soils are liquefiable:** Not required for buried structures as per the Bridge Manual 2.3.10

**Confirm feasibility of the proposed foundation or wall type and provide design parameters. Attach a pile design table indicating feasible pile types, various nominal required bearings, factored resistances available and corresponding estimated lengths at locations where piles will be used. Provide factored bearing resistance and unit sliding resistance at various elevations and confirm no ground improvement/treatment is necessary where spread footings are proposed. Estimated top of rock elevations as well as preliminary factored unit side and tip resistance values shall be indicated when drilled shafts are proposed:** The proposed culvert and wingwalls should be designed based on factored bearing resistance of 5,500.0 psf, the boring logs show stiff to hard clay below the length of the structure. The design drawings are showing that the 6'x 3' culvert will have horizontal cantilever wingwall at north side of the culvert. It will serve as a drainage path to transfer water from the proposed drainage ditch (soth of the proposed culvert) to the (north of the proposed culvert) that is going under I-80. Design parameters for lateral soil properties are provided in appendix F.

**Calculate the estimated water surface elevation and determine the need for cofferdams (type 1 or 2), and seal coat:** The construction site will be dewatered. Cofferdam will not be needed.

**Assess the need for sheeting or soil retention or temporary construction slope and provide recommendation for other construction concerns:** Per the structural engineering (GKE), temporary soil retention system (TSRS) will be required for staging of construction. Boring encountered on confined compressive strength exceeding 4.5 tons per square foot (tsf) which exceeds the requirements of the IDOT temporary sheet pile design guide. The design of the TSRS is the responsibility of the contractor.

**APPENDIX A**  
**General Notes**

## GENERAL NOTES

### CLASSIFICATION

American Association of State Highway & Transportation Officials (AASHTO) System used for soil classification.

#### Cohesionless Soils

<u>Relative Density</u>	<u>No. of Blows per foot N</u>
Very Loose	0 to 4
Loose	4 to 10
Medium Dense	10 to 30
Dense	30 to 50
Very Dense	Over 50

#### TERMINOLOGY

**Streaks** are considered to be paper thick. **Lenses** are considered to be less than 2 inches thick. **Layers** are considered to be less than 6 inches thick. **Stratum** are considered to be greater than 6 inches thick.

#### Cohesive Soils

<u>Consistency</u>	<u>Unconfined Compressive Strength - qu (tsf)</u>
Very Soft	Less than 0.25
Soft	0.25 - 0.5
Medium Stiff	0.5 - 1.0
Stiff	1.0 - 2.0
Very Stiff	2.0 - 4.0
Hard	Over 4.0

### DRILLING AND SAMPLING SYMBOLS

SS: Split Spoon 1-3/8" I.D., 2" O.D.	HS: Housel Sampler
ST: Shelby Tube 2" O.D., except where noted	WS: Wash Sample
AS: Auger Sample	FT: Fish Tail
DB: Diamond Bit - NX: BX: AX	RB: Rock Bit
CB: Carboloj Bit - NX: BX: AX	WO: Wash Out
OS: Osterberg Sampler	

Standard "N" Penetration: Blows per foot of a 140 lb. hammer falling 30" on a 2" O.D. Split Spoon

### WATER LEVEL MEASUREMENT SYMBOLS

WL: Water	WD: While Drilling
WCI: Wet Cave In	BCR: Before Casing Removal
DCI: Dry Cave In	ACR: After Casing Removal
WS: While sampling	AB: After Boring

Water levels indicated on the boring logs are the levels measured in the boring at the times indicated. In pervious soils, the indicated elevations are considered reliable ground water levels. In impervious soils, the accurate determination of ground water elevations is not possible in even several days observation, and additional evidence on ground water elevations must be sought.

**APPENDIX B**  
**SITE LOCATION MAP**



SITE MAP
EXP, IL 80 Culvert 1, New Lenox, IL

  
**Geo Services, Inc.**  
 Geotechnical, Environmental & Civil Engineering  
 805 Amherst Court, Suite 204  
 Naperville, Illinois 60565  
 (630) 355-2838

DRAWN BY	SP
APPROVED BY	NMA
DATE	October 14, 2022
GSI JOB No.	20012
SCALE	NTS

**APPENDIX C**  
**BORING LOCATION MAP**



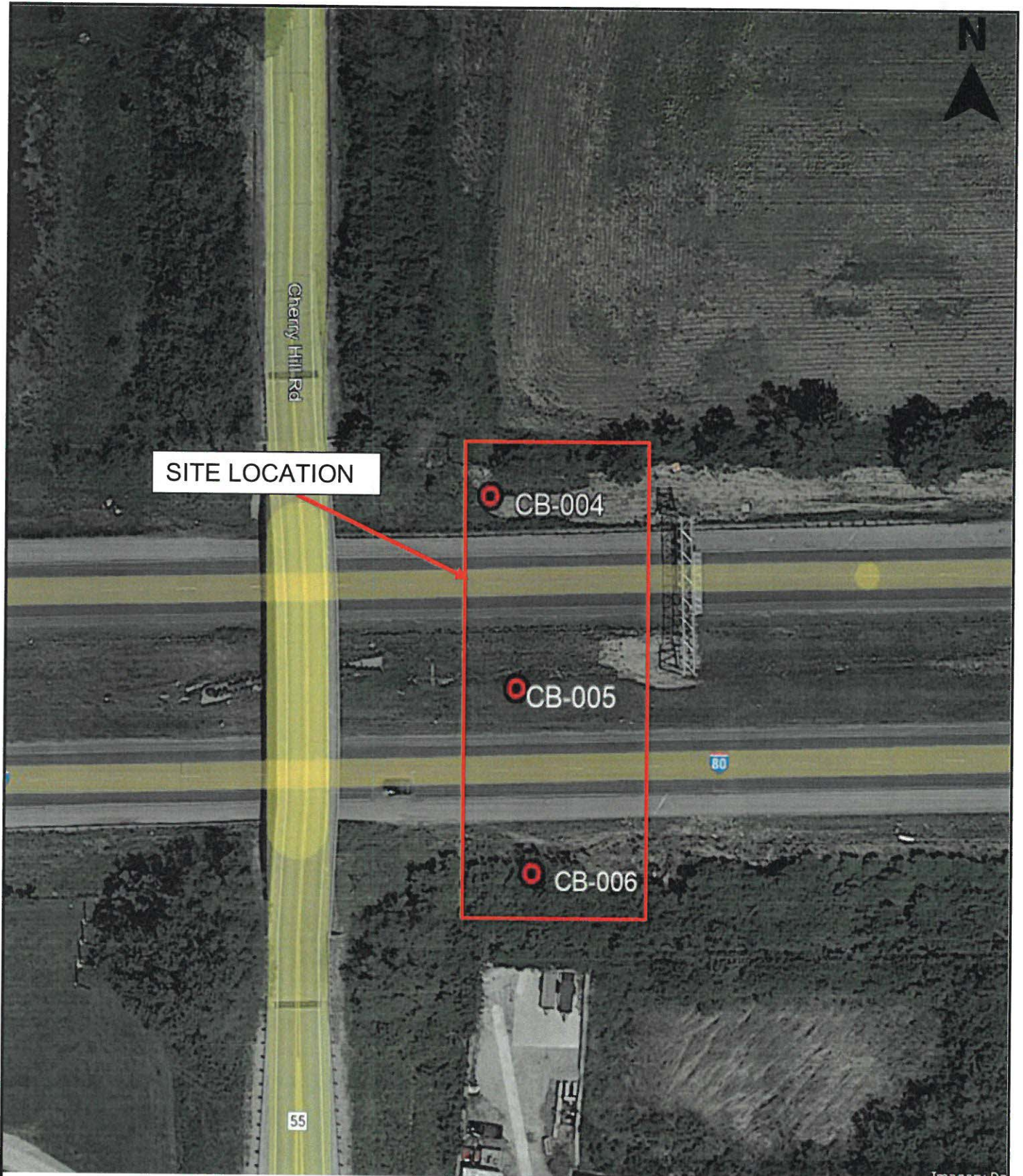

Boring Location Map	 <p><b>Geo Services, Inc.</b>          Geotechnical, Environmental &amp; Civil Engineering          805 Amherst Court, Suite 204          Naperville, Illinois   60565          (630) 355-2838</p>	DRAWN BY	NMA
EXP, IL 80 Culvert 1,		APPROVED BY	AP
New Lenox, IL		DATE	October 17, 2022
		GSI JOB No.	20012
		SCALE	NTS

**APPENDIX D**  
**BORING LOGS**



Geo Services, Inc.

Geotechnical, Environmental & Civil Engineering
805 Amherst Court, Suite 204
Naperville, Illinois 60565
(630) 355-2838

SOIL BORING LOG

Date 2/11/22

ROUTE FAU-363 (Briggs St) DESCRIPTION I-80 Phase II LOGGED BY DJ

SECTION 18 LOCATION SW 1/4, SEC. 18, TWP. T35N, RNG. R11E, 3rd PM,

Northing 1765544.141, Easting 1069142.566

COUNTY Will DRILLING METHOD Hollow Stem Auger HAMMER TYPE CME Automatic

STRUCT. NO. - Station -

BORING NO. CB-004 Station 866+72 Offset 62.6 ft Left Ground Surface Elev. 644.30 ft

DEPTH (ft) BLOW S (6") UCS (tsf) MOIST (%)

Surface Water Elev. n/a ft Stream Bed Elev. n/a ft Groundwater Elev.: First Encounter 638.304 ft Upon Completion After - Hrs.

DEPTH (ft) BLOW S (/6") UCS (tsf) MOIST (%)

Table with 5 main columns: Soil Description, Depth (ft), Blow S (6"), UCS (tsf), and Moist (%). Rows include soil types like 12.0" TOPSOIL-black and CLAY LOAM-brown & gray-stiff to hard, with various depth intervals and blow counts.

SOIL BORING 20012\_LOG.GPJ IL\_DOT.GDT 10/17/22

The Unconfined Compressive Strength (UCS) Failure Mode is indicated by (B-Bulge, S-Shear, P-Penetrometer) The SPT (N value) is the sum of the last two blow values in each sampling zone (AASHTO T206)



# Geo Services, Inc.

Geotechnical, Environmental & Civil Engineering  
805 Amherst Court, Suite 204  
Naperville, Illinois 60565  
(630) 355-2838

# SOIL BORING LOG

Date 3/16/22

ROUTE FAU-363 (Briggs St) DESCRIPTION I-80 Phase II LOGGED BY MM

SECTION 18 LOCATION SW 1/4, SEC. 18, TWP. T35N, RNG. R11E, 3<sup>rd</sup> PM,

Northing , Easting

COUNTY Will DRILLING METHOD Hollow Stem Auger HAMMER TYPE CME Automatic

STRUCT. NO. -  
Station -

BORING NO. CB-005  
Station 866+80  
Offset 5 ft Left  
Ground Surface Elev. 644.60 ft

D E P T H (ft)	B L O W S (/6")	U C S  Qu (tsf)	M O I S T  (%)
-------------------------------	--------------------------------	--------------------------------	----------------------------------

Surface Water Elev. n/a ft  
Stream Bed Elev. n/a ft  
Groundwater Elev.:  
First Encounter Dry ft  
Upon Completion Dry ft  
After - Hrs. - ft

D E P T H (ft)	B L O W S (/6")	U C S  Qu (tsf)	M O I S T  (%)
-------------------------------	--------------------------------	--------------------------------	----------------------------------

12.0" ASPHALT				End Of Boring @ -20.0'. Boring backfilled with cuttings.
	643.60			
CLAY LOAM-brown-stiff to very stiff		3		
		4	1.60	20
		4	B	
		3		
		5	3.10	20
	-5	5	B	-25
		3		
		7	3.70	20
		9	B	
		3		
		8	2.70	22
	-10	9	B	-30
		4		
		6	2.70	23
		9	B	
becoming gray @ -13.0'		3		
		4	2.00	22
	-15	6	P	-35
		2		
		4	1.50	23
		4	P	
		4		
		3	1.25	23
	624.60	6	P	-40

SOIL BORING - 20012\_LOG.GPJ IL\_DOT.GDT 10/17/22

The Unconfined Compressive Strength (UCS) Failure Mode is indicated by (B-Bulge, S-Shear, P-Penetrometer)  
The SPT (N value) is the sum of the last two blow values in each sampling zone (AASHTO T206)



# Geo Services, Inc.

Geotechnical, Environmental & Civil Engineering  
 805 Amherst Court, Suite 204  
 Naperville, Illinois 60565  
 (630) 365-2838

# SOIL BORING LOG

Date 12/9/21

ROUTE FAU-363 (Briggs St) DESCRIPTION I-80 Phase II LOGGED BY LP

SECTION 18 LOCATION SW 1/4, SEC. 18, TWP. T35N, RNG. R11E, 3<sup>rd</sup> PM,

Northing 1765417.3, Easting 1069159.1

COUNTY Will DRILLING METHOD Hollow Stem Auger HAMMER TYPE CME Automatic

STRUCT. NO. -  
 Station -

BORING NO. CB-006  
 Station 866+85  
 Offset 64.7 ft Right  
 Ground Surface Elev. 644.90 ft

DEPTH H (ft)	BLOW S (/6")	UCS Qu (tsf)	MOIST T (%)	Surface Water Elev. <u>n/a</u> ft	Stream Bed Elev. <u>n/a</u> ft	Groundwater Elev.:	DEPTH H (ft)	BLOW S (/6")	UCS Qu (tsf)	MOIST T (%)
						First Encounter <u>Dry</u> ft				
						Upon Completion <u>Dry</u> ft				
						After <u>-</u> Hrs. <u>-</u> ft				

8.0" ASPHALT	644.23					End Of Boring @ -20.0'. Boring backfilled with cuttings.				
CLAY LOAM-brown-very stiff to hard		6								
		3	3.00	19						
		5	P							
		4								
		4	6.60	21						
		-5	7	B			-25			
		5								
		8	6.60	21						
		10	B							
		6								
		10	3.10	21						
		-10	13	B			-30			
	634.40									
CLAY-gray-very stiff		4								
		7	3.00	20						
		7	P							
		3								
		5	2.00	21						
		-15	7	P			-35			
		3								
		5	2.00	22						
		4	P							
		3								
		5	2.00	22						
		-20	5	P			-40			
	624.90									

SOIL BORING 20012\_LOG.GPJ IL\_DOT.GDT 10/17/22

The Unconfined Compressive Strength (UCS) Failure Mode is indicated by (B-Bulge, S-Shear, P-Penetrometer)  
 The SPT (N value) is the sum of the last two blow values in each sampling zone (AASHTO T206)

**APPENDIX E**  
**CULVERT CROSS-SECTION**

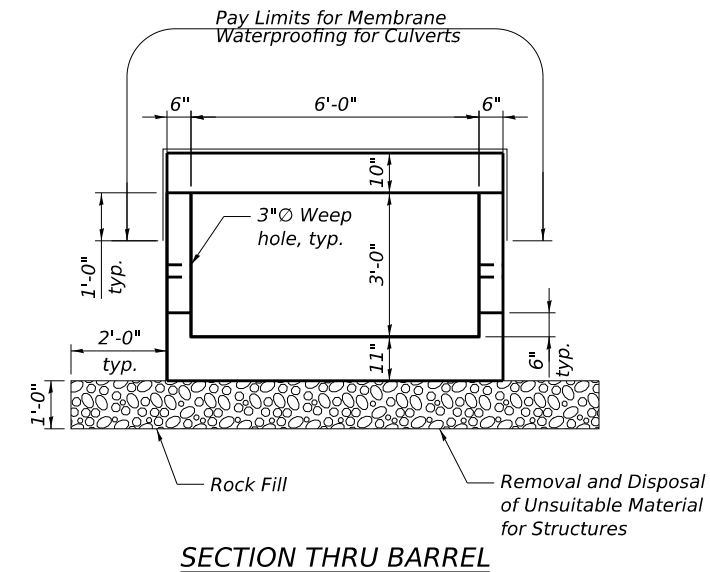
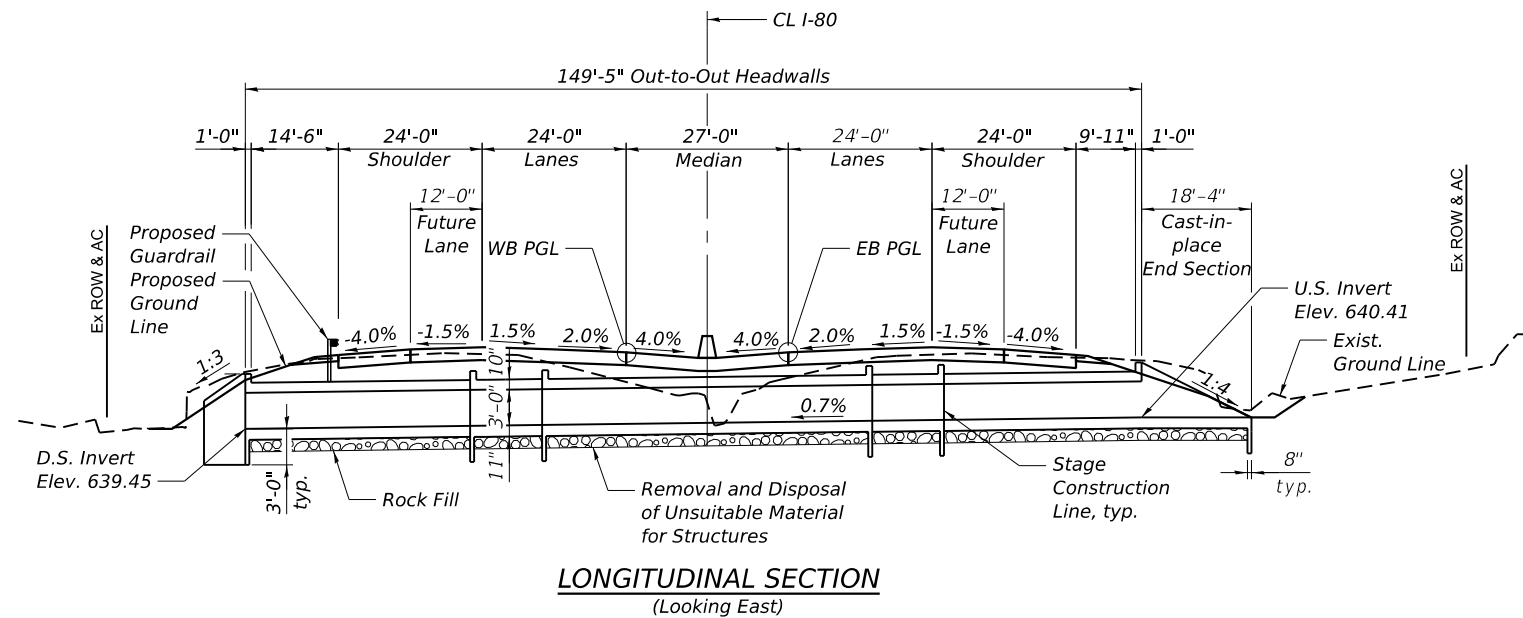

**LOADING HL-93**  
Allow 50#/sq.ft. for future wearing surface.

**DESIGN SPECIFICATIONS**  
2020 AASHTO LRDF Bridge Design Specifications, 9th Edition

**DESIGN STRESSES**  
FIELD UNITS  
f<sub>c</sub> = 3500 psi  
f<sub>y</sub> = 60000 psi (Reinforcement)

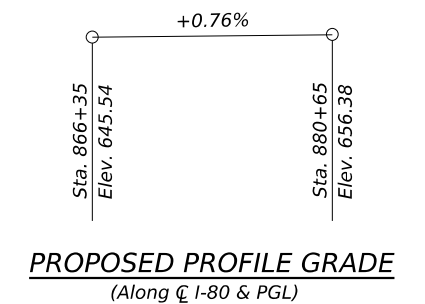
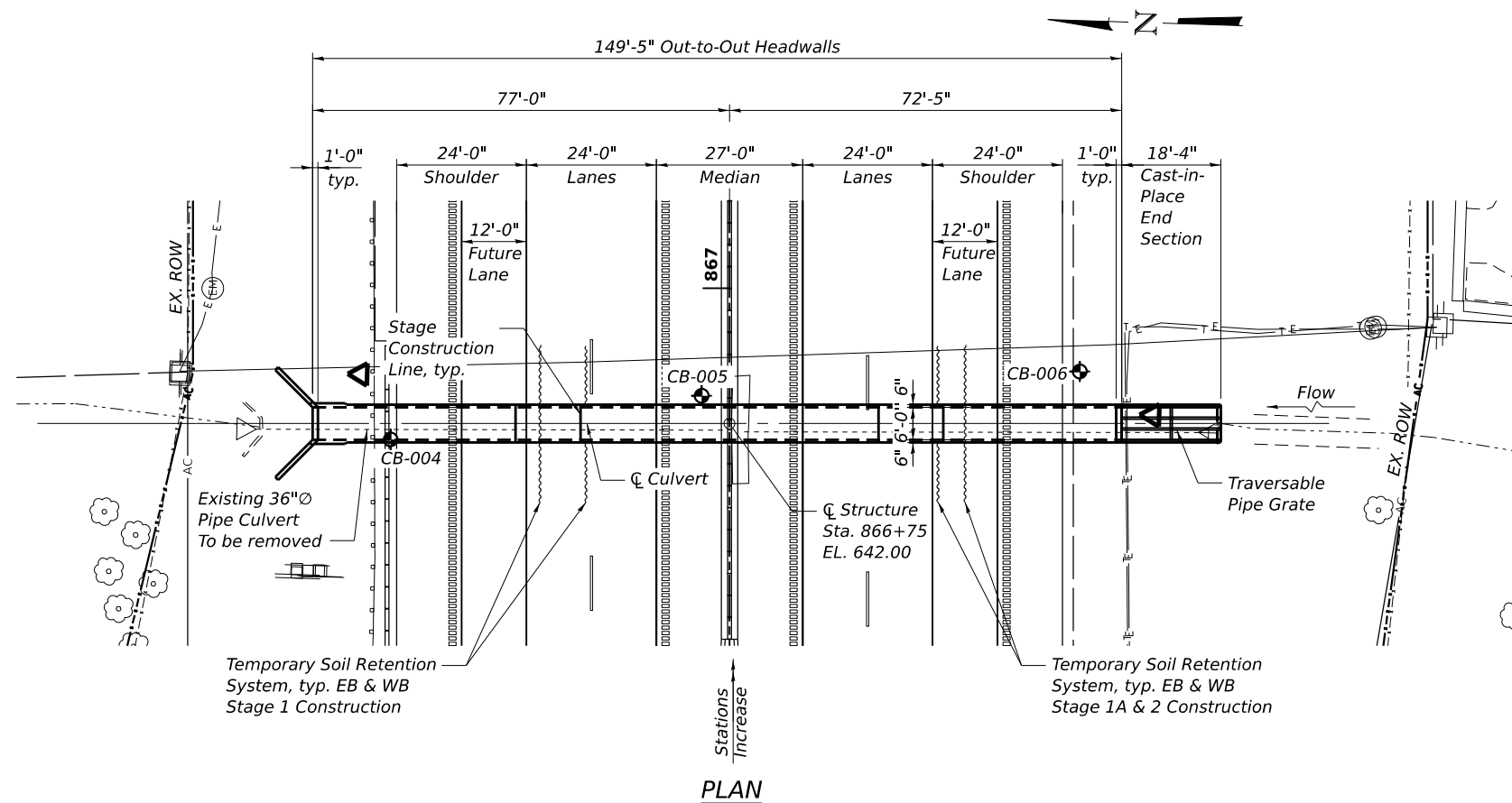

**GENERAL PLAN AND ELEVATION**  
F.A.I ROUTE 80  
WILL COUNTY  
STA. 866+75

MODEL: DEFAULT  
FILE NAME: \$\$\$FILE\$\$\$\$

**garza karhoff**  
ENGINEERING, LLC

USER NAME =	DESIGNED - UT	REVISED -
PLOT SCALE =	CHECKED - LM	REVISED -
PLOT DATE =	DRAWN - UT	REVISED -
	CHECKED - LM	REVISED -

**STATE OF ILLINOIS**  
**DEPARTMENT OF TRANSPORTATION**

**GENERAL PLAN & ELEVATION**  
**BOX CULVERT AT 863+75**

SHEET S-1 OF S-8 SHEETS

F.A.I. RTE.	SECTION	COUNTY	TOTAL SHEETS	SHEET NO.
80	FAI 80 21 STRUCTURE 8	WILL	766	299
CONTRACT NO. 62R29				

ILLINOIS FED. AID PROJECT

SDATES \$TIMES

**GENERAL NOTES**

1. Reinforcement bars designated (E) shall be epoxy coated.
2. Slopewall shall be reinforced with welded wire fabric, 6" x 6" - W4.0 x W4.0, weighing 58 lbs. per 100 sq. ft.
3. Protective coat shall not be applied to surfaces to which Waterproofing Membrane System is applied.
4. Precast alternate is not allowed.
5. See Civil Plans for additional information.
6. Geocomposite Wall Drain shall be according to Section 591 of Standard Specification, except that concrete nails shall not be used in areas where it overlaps Membrane Waterproofing System for Buried Structures.

**INDEX OF SHEETS**

1. General Plan
2. General Notes, Index of Sheets and Total Bill of Materials
3. Stage Construction Details
- 4-5. Culvert Plan and Details
6. Transversable Pipe Grate Details for End Section
7. Bar Splicer Assembly and Mechanical Splicer Details
8. Soil Boring Logs

**TOTAL BILL OF MATERIAL**

ITEM	UNIT	TOTAL
Porous Granular Embankment	Cu. Yd.	230
Removal and Disposal of Unsuitable Material for Structures	Cu. Yd.	61
Reinforced Bars, Epoxy Coated	Pound	19,930
Bar Splacers	Each	96
Temporary Soil Retention System	Sq. Ft.	845
Concrete Box Culverts	Cu. Yd.	84.2
Traversable Pipe Grate for Concrete End Section	Foot	33
Membrane Waterproofing for Culverts	Sq. Yd.	116
Rock Fill	Cu. Yd.	61

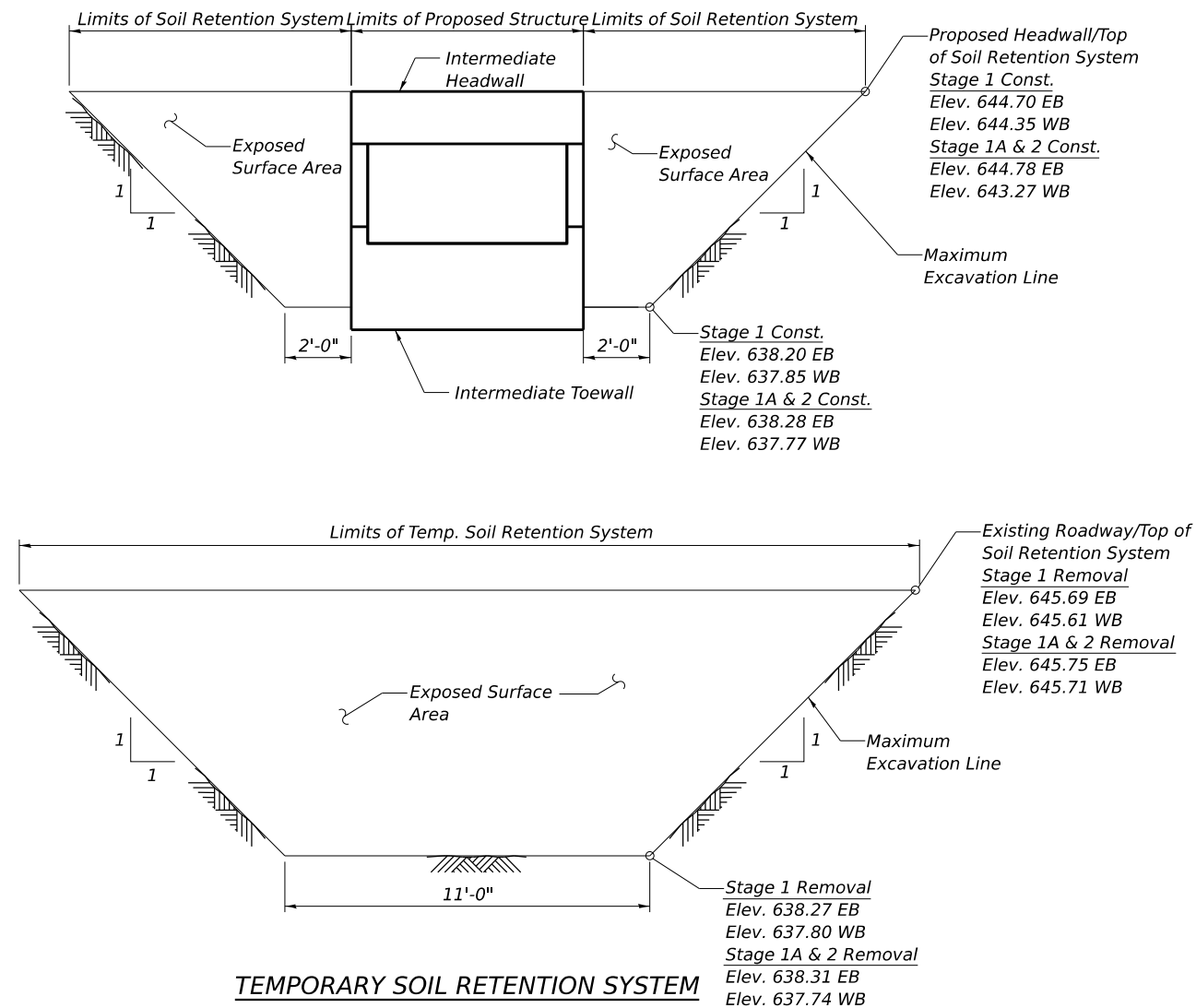

**NOTE:**

A cantilevered sheet piling design does not appear feasible and additional members or other retention systems may be necessary. The Contractor shall submit a temporary soil retention system design including plan details and calculations for review and acceptance by the Engineer.

MODEL: DEFAULT  
FILE NAME: \$\$FILE\$\$



USER NAME =	DESIGNED - UT	REVISED -
CHECKED - LM	REVISED -	
PLOT SCALE =	DRAWN - UT	REVISED -
PLOT DATE =	CHECKED - LM	REVISED -

STATE OF ILLINOIS  
DEPARTMENT OF TRANSPORTATION

GENERAL NOTES, INDEX OF SHEETS, & TOTAL BILL OF MATERIALS  
BOX CULVERT AT 866+75

SHEET S-2 OF S-8 SHEETS

F.A.I. RTE.	SECTION	COUNTY	TOTAL SHEETS	SHEET NO.
80	FAI 80 21 STRUCTURE 8	WILL	766	300
CONTRACT NO. 62R29				

ILLINOIS FED. AID PROJECT

SDATES \$ TIMES \$



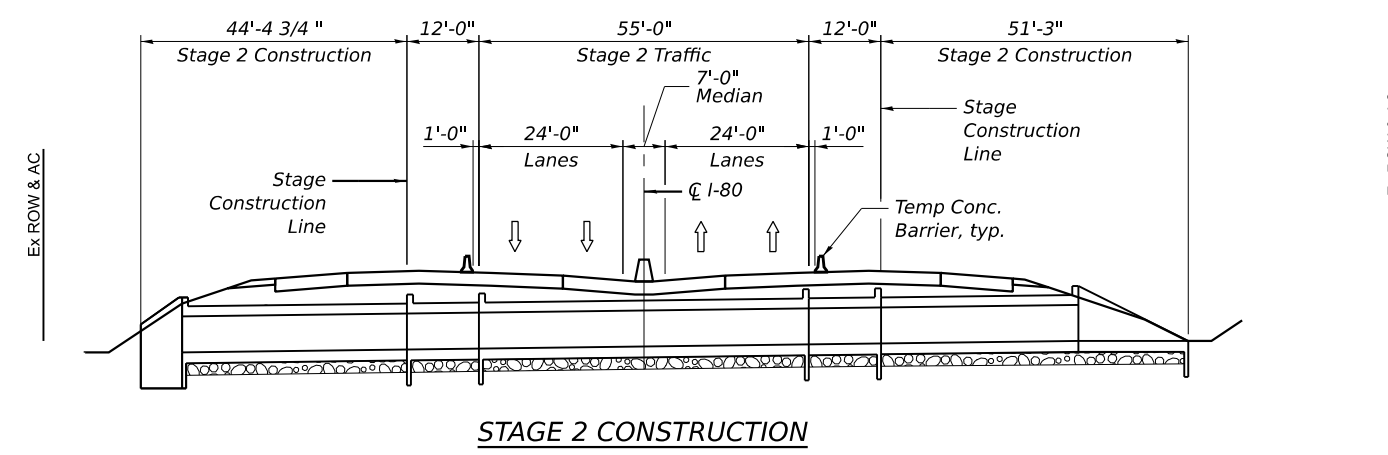
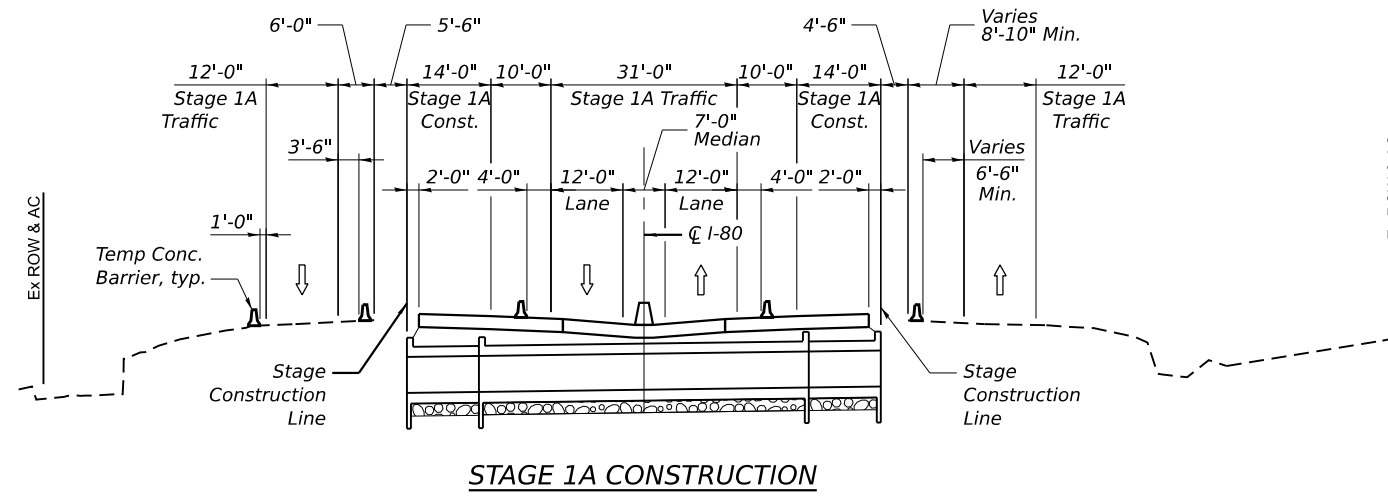
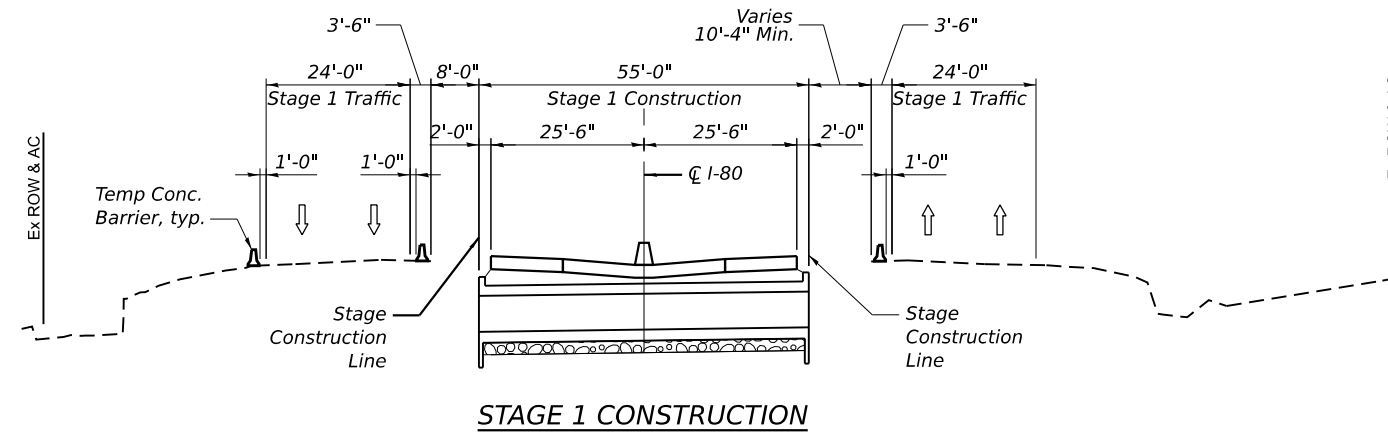

MODEL: DEFAULT  
FILE NAME: \$\$FILE\$\$



USER NAME =	DESIGNED - UT	REVISED -
	CHECKED - LM	REVISED -
PLOT SCALE =	DRAWN - UT	REVISED -
PLOT DATE =	CHECKED - LM	REVISED -

STATE OF ILLINOIS  
DEPARTMENT OF TRANSPORTATION

STAGE CONSTRUCTION DETAILS  
BOX CULVERT AT 863+75

SHEET S-3 OF S-8 SHEETS

F.A.I. RTE.	SECTION	COUNTY	TOTAL SHEETS	SHEET NO.
80	FAI 80 21 STRUCTURE 8	WILL	766	301
CONTRACT NO. 62R29				

ILLINOIS FED. AID PROJECT

\$DATES\$ \$TIMES\$

149'-5" Out to Out Headwalls (Along C̄ Culvert)

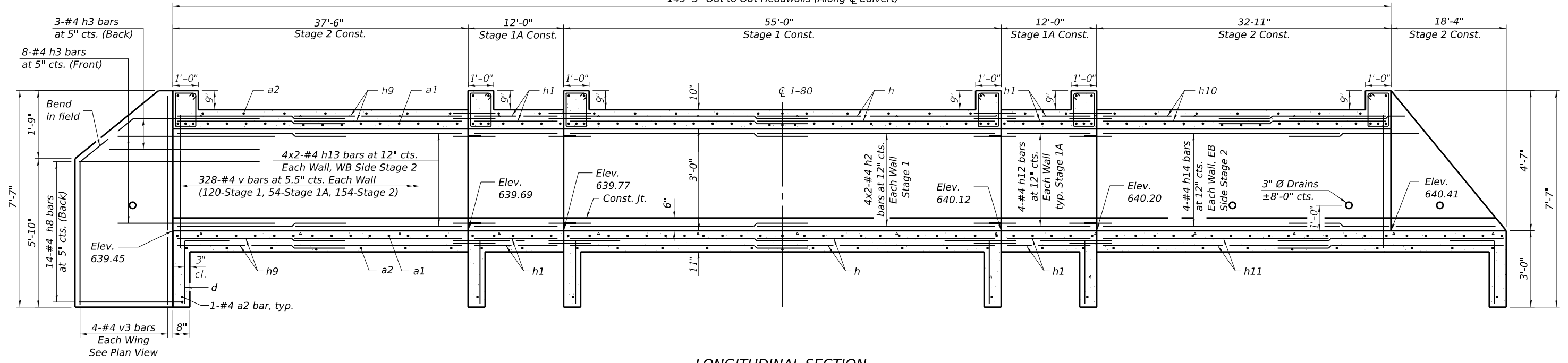

LONGITUDINAL SECTION

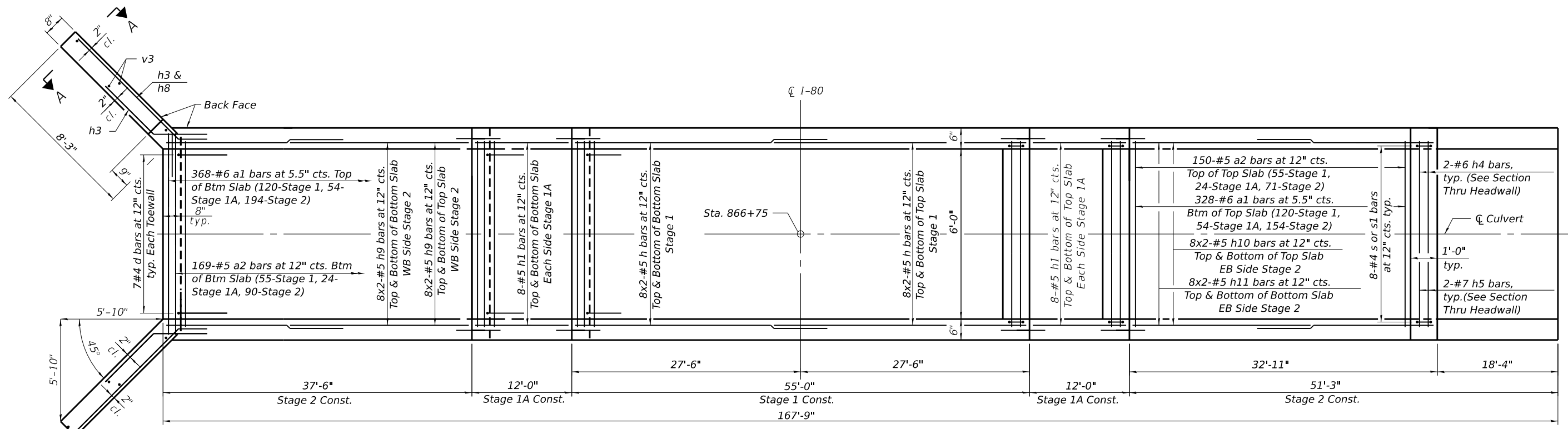

SHOWING TOEWALL

PLAN

SHOWING HEADWALLS

Notes:  
 A distance of half the length of the wingwall but not less than six feet of the barrel shall be poured monolithically with the wingwalls.  
 Bars indicated thus 12 x 4-#5 etc. indicates 12 lines of bars with 4 lengths per line.  
 See Culvert Details (2 of 2) for End Section Reinforcement, Details, and Bill of Materials.

MODEL: DEFAULT  
 FILE NAME: \$\$\$FILEL\$\$

**garza karhoff**  
 ENGINEERING, LLC

USER NAME =	DESIGNED - JJM	REVISED -
PLOT SCALE =	CHECKED - LM	REVISED -
PLOT DATE =	DRAWN - JJM	REVISED -
	CHECKED - LM	REVISED -

STATE OF ILLINOIS  
 DEPARTMENT OF TRANSPORTATION

CULVERT DETAILS 1  
 BOX CULVERT AT 863+75

SHEET S-4 OF S-8 SHEETS

F.A.I. RTE.	SECTION	COUNTY	TOTAL SHEETS	SHEET NO.
80	FAI 80 21 STRUCTURE 8	WILL	766	302
CONTRACT NO. 62R29				
ILLINOIS FED. AID PROJECT				

SDATES \$TIMES

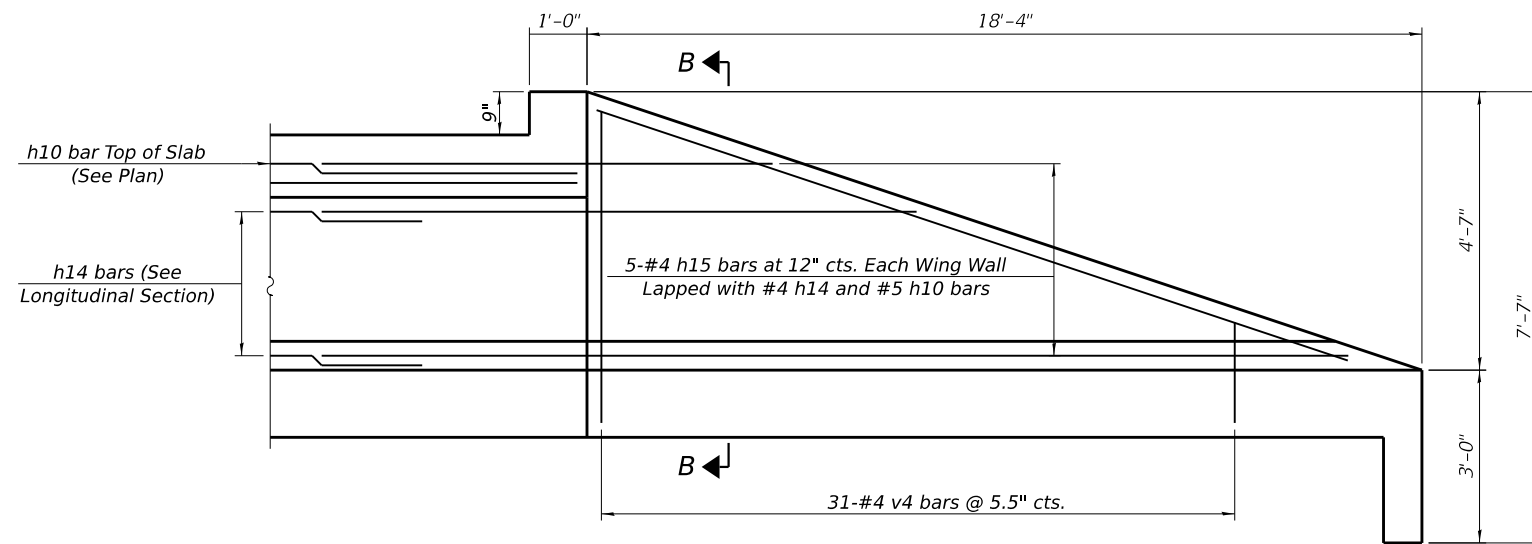

**END SECTION ELEVATION**  
 Top & Bottom Slab Reinforcement not show. See Plan and Longitudinal Section for details.

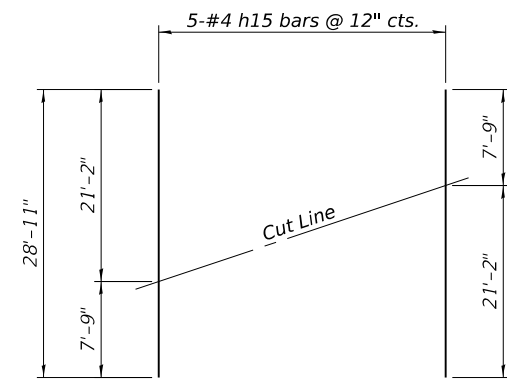

**FIELD CUTTING DIAGRAM**  
 Order bars full length. Cut as shown and use remainder of bars in the opposite side. Two sets of field cuts required.

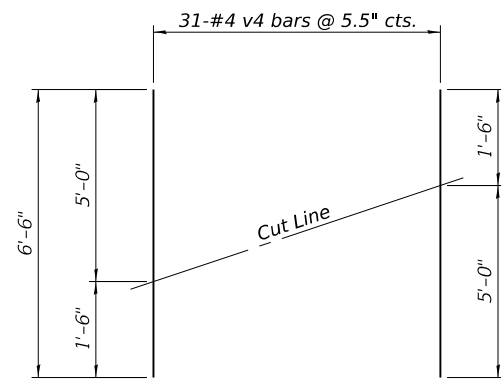

**FIELD CUTTING DIAGRAM**  
 Order bars full length. Cut as shown and use remainder of bars in the opposite Wing Wall. Two sets of field cuts required.

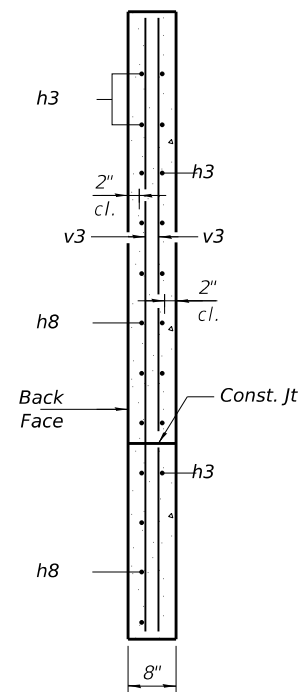

**SECTION A-A**

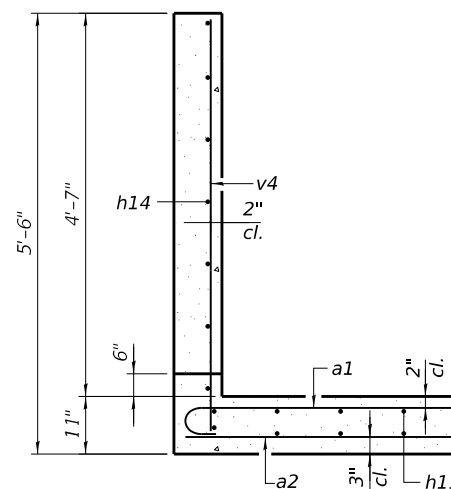

**SECTION B-B**

**MIN. BAR LAP**

#4 bar = 1'-9"  
 #5 bar = 2'-2"

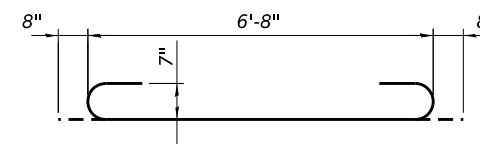

**BAR a1**

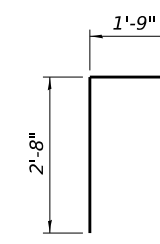

**BAR d**

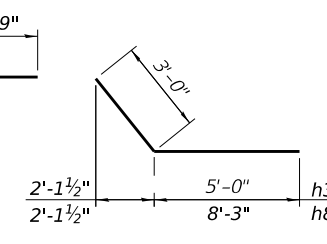

**BARS h3 & h8**

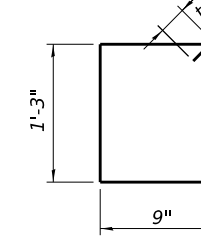

**BAR s**

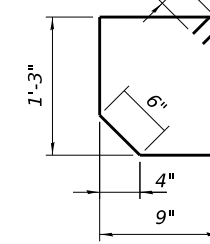

**BAR s1**

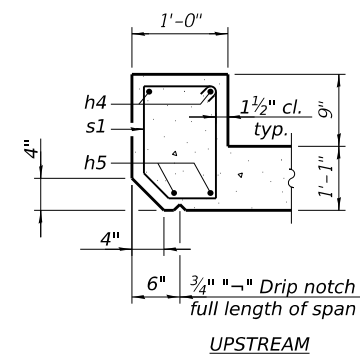

**UPSTREAM**

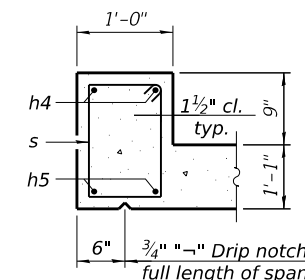

**DOWNSTREAM**

Tilt hook of a1 bars if necessary for 2" min. cl.

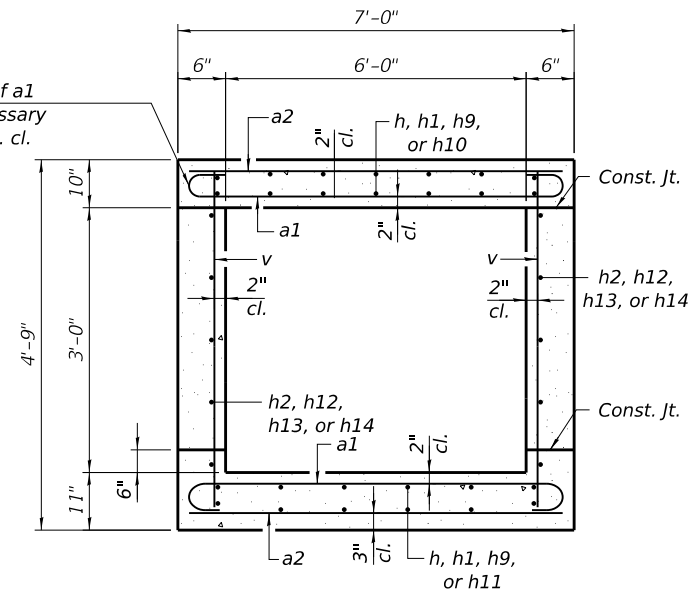

**SECTION THRU BARREL**

**BILL OF MATERIAL**

Bar	No.	Size	Length	Shape
a1	696	#6	8'-0"	
a2	325	#5	6'-8"	
d	42	#4	4'-5"	
h	64	#5	28'-5"	
h1	64	#5	11'-8"	
h2	16	#4	28'-3"	
h3	22	#4	8'-0"	
h4	12	#6	6'-8"	
h5	12	#7	6'-8"	
h8	28	#4	11'-3"	
h9	64	#5	19'-8"	
h10	32	#5	17'-5"	
h11	32	#5	26'-7"	
h12	16	#4	11'-8"	
h13	16	#4	19'-6"	
h14	8	#4	30'-0"	
h15	5	#4	28'-11"	
s	40	#4	4'-9"	
s1	8	#4	4'-7"	
v	656	#4	4'-4"	
v3	8	#4	7'-3"	
v4	31	#4	6'-6"	
Concrete Box Culverts			Cu. Yd.	84.2
Reinforcement Bars			Pound	19,930

MODEL: DEFAULT  
 FILE NAME: \$\$\$FILE\$\$\$

**garza karhoff**  
 ENGINEERING, LLC

USER NAME =	DESIGNED - JJM	REVISED -
PLOT SCALE =	CHECKED - LM	REVISED -
PLOT DATE =	DRAWN - JJM	REVISED -
	CHECKED - LM	REVISED -

**STATE OF ILLINOIS**  
**DEPARTMENT OF TRANSPORTATION**

**CULVERT DETAILS 2**  
**BOX CULVERT AT 863+75**

SHEET S-5 OF S-8 SHEETS

F.A.I. RTE.	SECTION	COUNTY	TOTAL SHEETS	SHEET NO.
80	FAI 80 21 STRUCTURE 8	WILL	766	303
CONTRACT NO. 62R29				
ILLINOIS FED. AID PROJECT				

SDATES \$TIMES

**GENERAL NOTES**

The minimum edge distance from the center of a hole to the free edge of a structural shape or plate shall be 1½" unless noted otherwise.

The Contractor may install the thru bolts using drilling and grouting in lieu of providing a formed hole using steel pipe. Installation shall be in accordance with Article 509.06 using a method that results in the annulus surrounding the bolt being completed filled with adhesive. The method of drilling shall not result in spalled concrete at the exit face. Epoxy grouted thru bolts shall be snug tightened followed by an additional ½ turn on the interior nut at final installation. Cost included with Traversable Pipe Grate.

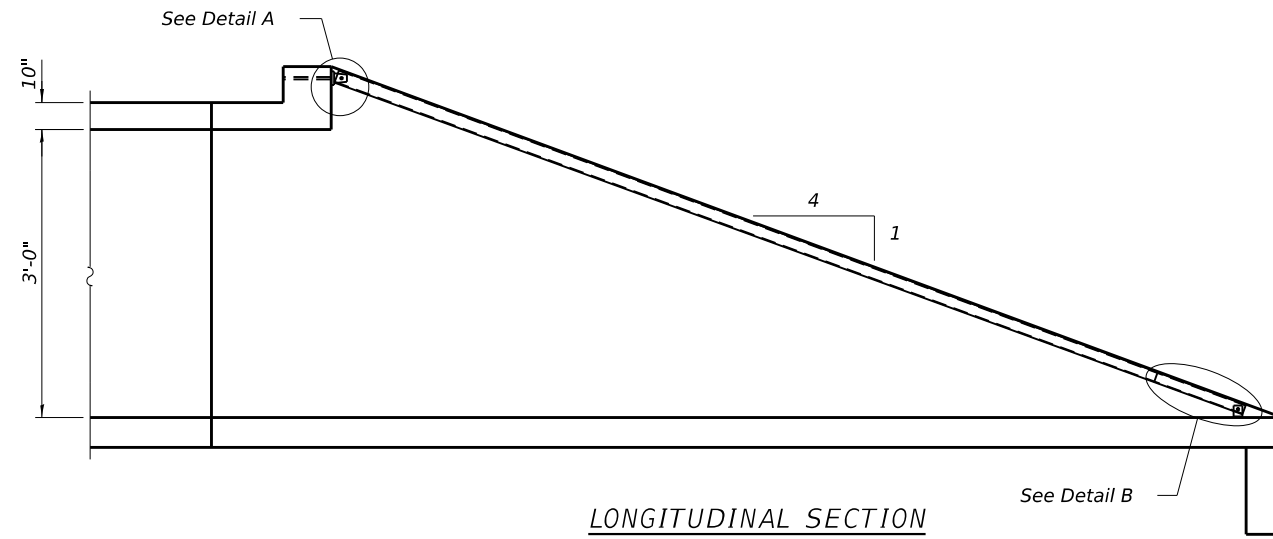

**LONGITUDINAL SECTION**

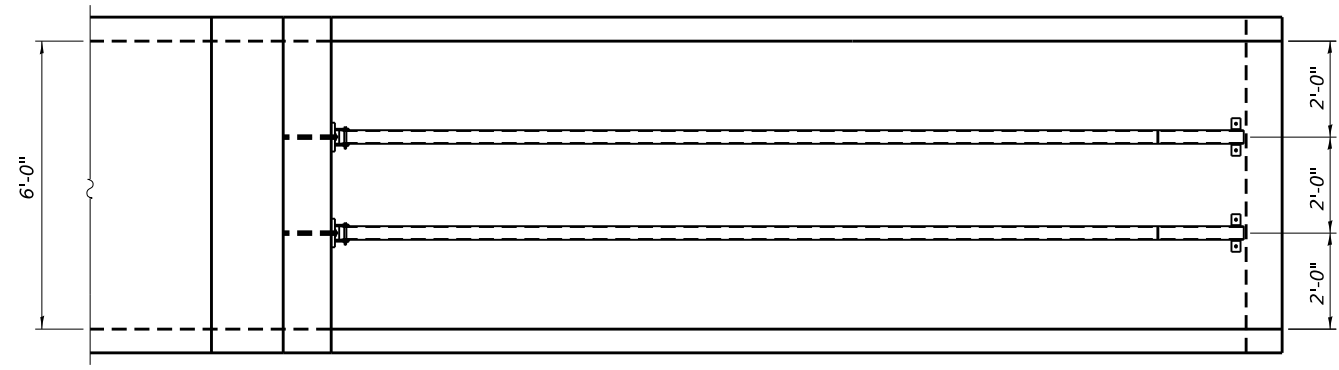

**PLAN VIEW**

Number and Length of Main Pipe is 2 @ 16'-6"

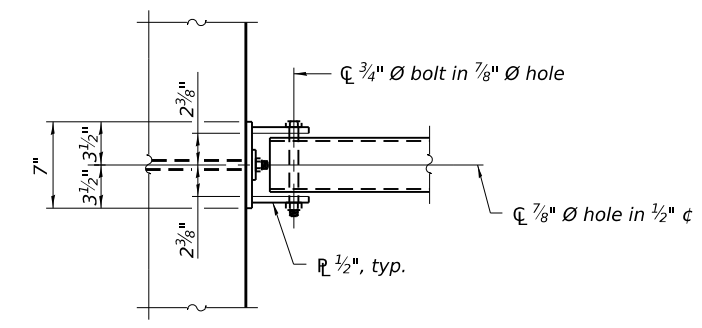

**VIEW A-A**

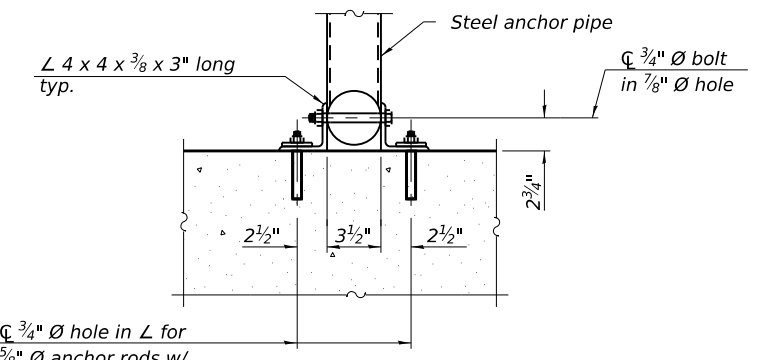

**SECTION B-B**

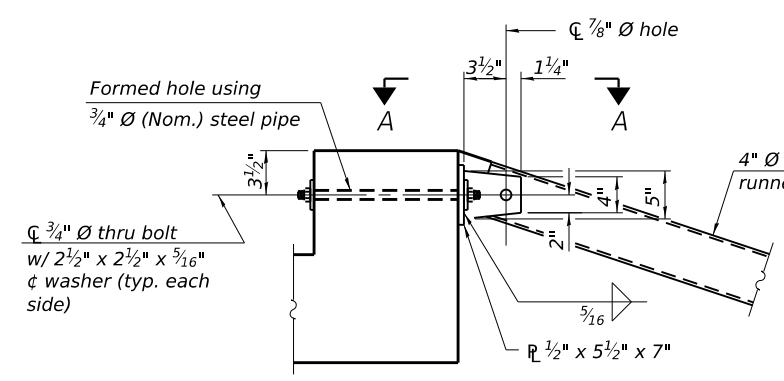

**DETAIL A**

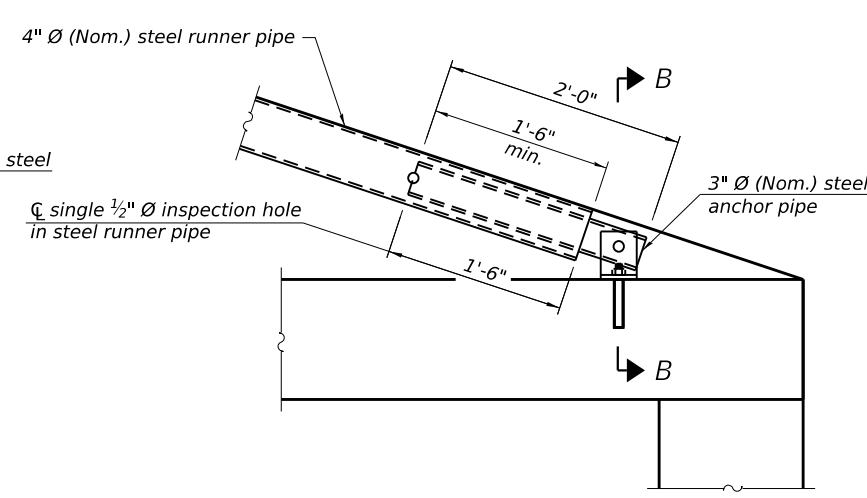

**DETAIL B**

**BILL OF MATERIAL**

ITEM	UNIT	TOTAL
Traversable Pipe Grate for Concrete End Section	Foot	33

MODEL: DEFAULT  
FILE NAME: \$\$\$FILE\$\$\$\$

**garza karhoff**  
ENGINEERING, LLC

USER NAME =	DESIGNED - UT	REVISED -
	CHECKED - LM	REVISED -
PLOT SCALE =	DRAWN - UT	REVISED -
PLOT DATE =	CHECKED - LM	REVISED -

**STATE OF ILLINOIS**  
**DEPARTMENT OF TRANSPORTATION**

**TRAVERSABLE PIPE GRATE DETAILS FOR END SECTION**  
**BOX CULVERT AT 863+75**

SHEET S-6 OF S-8 SHEETS

F.A.I. RTE.	SECTION	COUNTY	TOTAL SHEETS	SHEET NO.
80	FAI 80 21 STRUCTURE 8	WILL	766	304
CONTRACT NO. 62R29				
ILLINOIS FED. AID PROJECT				

SDATES\$ \$TIMES\$

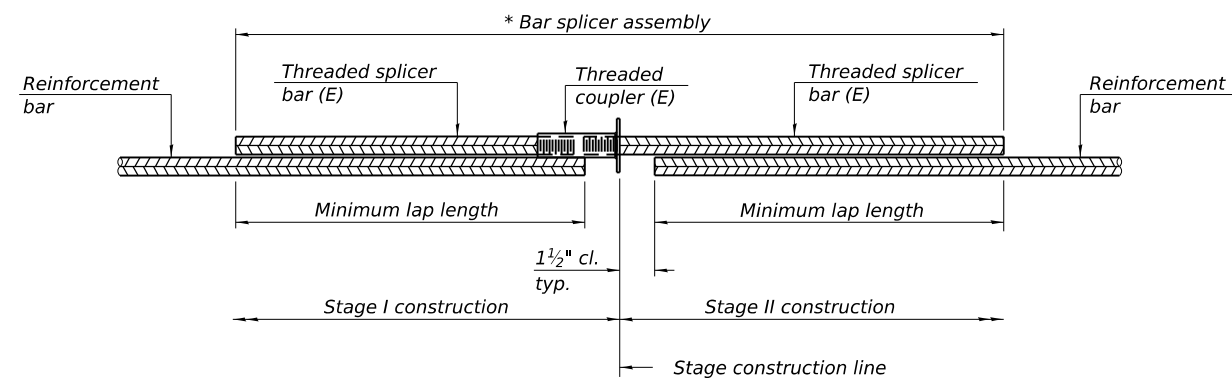

**STANDARD BAR SPLICER ASSEMBLY PLAN**  
 (All components shall be provided from one supplier)

Threaded splicer bar length = min. lap length + 1 1/2" + thread length

\* Epoxy not required on Bar Splicer Assembly components used in conjunction with black bars.

Location	Bar size	No. assemblies required	Minimum lap length
Barrel Stage 1	#5	32	2'-2"
Barrel Stage 1	#4	16	1'-9"
Barrel Stage 1A	#5	32	2'-2"
Barrel Stage 1A	#4	16	1'-9"

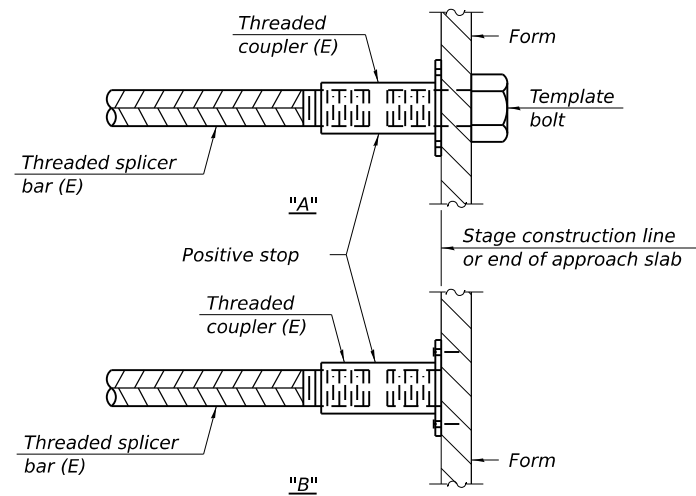

**INSTALLATION AND SETTING METHODS**

"A" : Set bar splicer assembly by means of a template bolt.

"B" : Set bar splicer assembly by nailing to wood forms or cementing to steel forms.

(E) : Indicates epoxy coating.

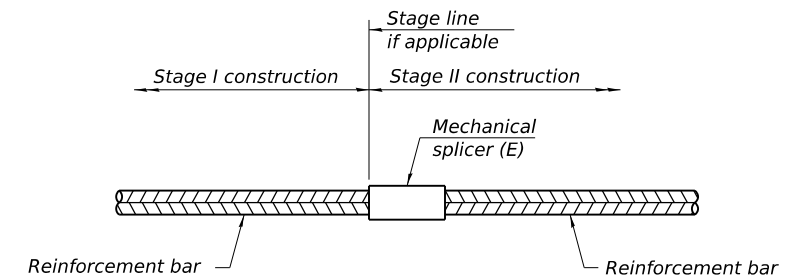

**STANDARD MECHANICAL SPLICER**

Location	Bar size	No. assemblies required

Notes:  
 Splicer bars shall be deformed with threaded ends and have a minimum 60 ksi yield strength.  
 All reinforcement shall be lapped and tied to the splicer bars.  
 Bar splicer assemblies shall be epoxy coated according to the requirements for reinforcement bars. See Section 508 of the Standard Specifications.  
 See approved list of bar splicer assemblies and mechanical splicers for alternatives.

MODEL: DEFAULT  
 FILE NAME: \$\$\$FILE\$\$\$\$

BSD-1 1-1-2020



USER NAME =	DESIGNED - UT	REVISED -
	CHECKED - LM	REVISED -
PLOT SCALE =	DRAWN - UT	REVISED -
PLOT DATE =	CHECKED - LM	REVISED -

STATE OF ILLINOIS  
 DEPARTMENT OF TRANSPORTATION

BAR SPLICER ASSEMBLY AND MECHANICAL SPLICER DETAILS  
 BOX CULVERT AT 863+75

SHEET S-7 OF S-8 SHEETS

F.A.I. RTE.	SECTION	COUNTY	TOTAL SHEETS	SHEET NO.
80	FAI 80 21 STRUCTURE 8	WILL	766	305
CONTRACT NO. 62R29				

ILLINOIS FED. AID PROJECT

SDATES\$ \$TIMES\$

## **APPENDIX F**

### **Long-term Geotechnical Parameters for Design Sheet Pile/Soldier Pile Walls**

**Table 1- Long-term Geotechnical Parameters for Design Sheet Pile/Soldier Pile Walls**

Material Description	Depth Below Ground Surface (ft)	Soil Unit Weight $\gamma$ (pcf)	Active Earth Pressure Coeff ( $K_a$ )	Passive Earth Pressure Coeff ( $K_p$ )	Cohesion "c" (pcf)	Lateral Modulus of Subgrade Reaction (pci)	Strain	Long term (drained) Cohesion "c" (pcf)	Long term (drained) Friction Angle ( $^\circ$ )
Stiff to Hard Clay Loam	1 to 10.5	120	0.36	2.7	3285	1092.26	0.0049	0	28
Very stiff Clay	10.5 to 20	120	0.37	2.6	2250	711.8	0.0065	0	27