

STATE OF ILLINOIS  
DEPARTMENT OF TRANSPORTATION

ROUTE NO. FAP 305	SECTION *	COUNTY Cook	DIST. 72	SHEET 66	SHEET NO. 8 14 SHEETS
FED. ROAD DIST. 101-7		ILLINOIS	FED. AID PROJECT		
Contract No. 62853		*2004-108 BR			

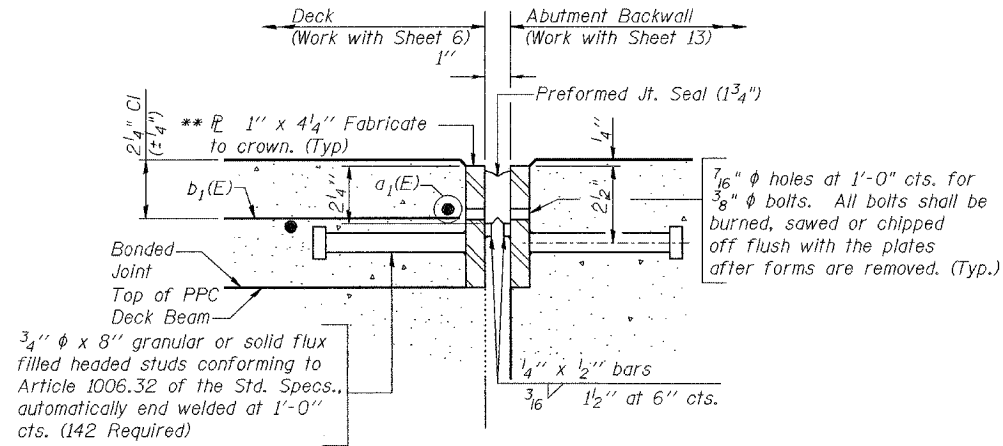

SECTION THRU 1 3/4" FIXED JOINT

\*\*Furnish in segments of 20 ft maximum length. Maximum space between installed segments shall be 3/16". Seal space with Silicon Sealant suitable for Structural Steel. Cost included with "Furnishing and Erecting Structural Steel."

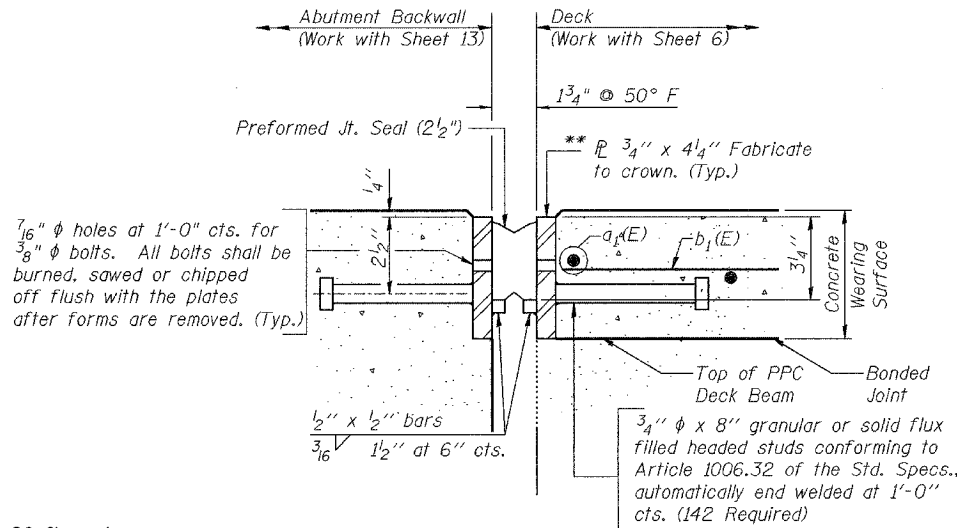

SECTION THRU 2 1/2" EXPANSION JOINT

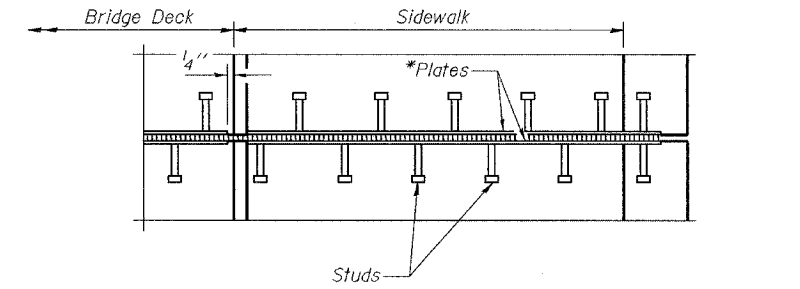

PLAN AT SIDEWALK

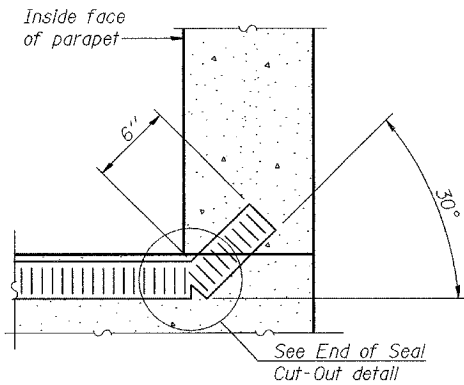

AT CURB, PARAPET, OR WALL  
(Showing seal)

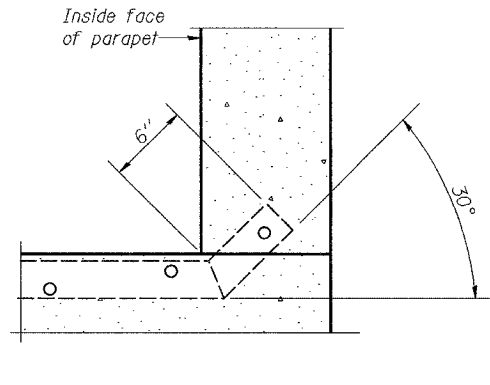

AT CURB, PARAPET, OR WALL  
(Showing plate)

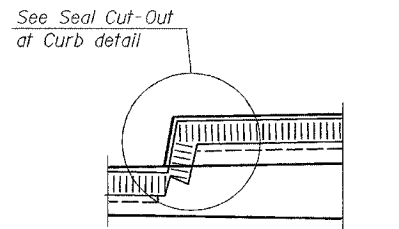

AT SIDEWALK OR MEDIAN

TYPICAL END TREATMENTS FOR PREFORMED JOINT SEAL

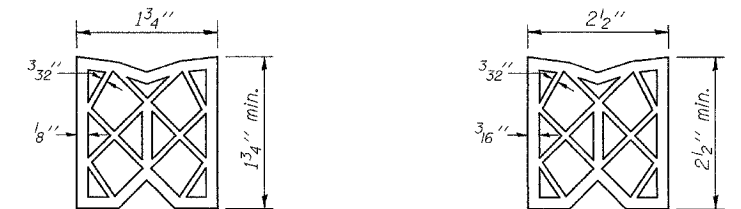

PREFORMED JOINT SEAL (1 3/4") PREFORMED JOINT SEAL (2 1/2")

DESIGNED	BPS
CHECKED	KFA
DRAWN	BPS
CHECKED	GSP

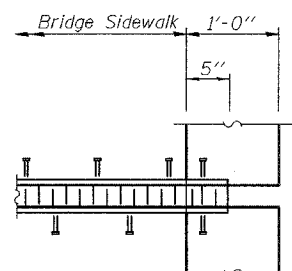

PLAN AT PARAPET

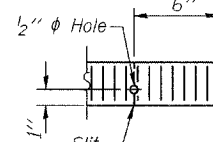

END OF SEAL CUT-OUT

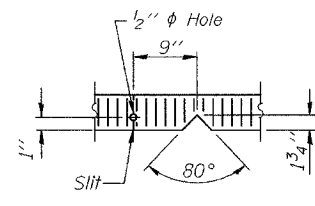

SEAL CUT-OUT AT CURB

BILL OF MATERIAL

Item	Unit	Quantity
Preformed Joint Seal 1 3/4"	Foot	70
Preformed Joint Seal 2 1/2"	Foot	70
Furnishing and Erecting Structural Steel	Pound	2,150

DECK JOINTS  
WOLF RD. OVER PALATINE RD.  
F.A.P. RTE. 305 SECT. 2004-108 BR  
COOK COUNTY  
STATION 950+00.00  
STRUCTURE NO. 016-0680