

STATE OF ILLINOIS
DEPARTMENT OF TRANSPORTATION

GENERAL NOTES

Fasteners shall be AASHTO M164 Type 1, mechanically galvanized bolts. Bolts 3/4-in. ϕ , holes 7/8-in. ϕ , unless otherwise noted.

No field welding is permitted except as specified in the contract documents.

The Contractor shall test the existing welds by non-destructive methods within 2 ft. of the end of the existing cover plates for cracks after removal of the existing concrete deck. Dye penetrant (PT), magnetic particle (MT), or other approved testing method shall be performed by qualified personnel approved by the Engineer. If cracks are found, report them to the Bureau of Bridges and Structures for disposition. The cost of testing is included in Removal of Existing Concrete Deck. The cost of crack repair, if necessary, will be paid for according to Article 109.04 of the Standard Specifications.

Reinforcement bars shall conform to the requirements of ASTM A 706 Gr 60. See Special Provisions.

Reinforcement bars designated (E) shall be epoxy coated.

Prior to pouring the new concrete deck, all heavy or loose rust, loose mill scale, and other loose or potentially detrimental foreign material shall be removed from the surfaces in contact with concrete. Tightly adhered paint may remain unless otherwise noted. Removal shall be accomplished by methods that will not damage the steel and the cost will be included in the pay item covering removal of the existing concrete.

As directed by the Engineer, existing construction accessories welded to the top flange of beams and girders shall be removed. The weld areas shall be ground flush and inspected for cracks using magnetic particle testing (MT) or dye penetrant testing (PT) by qualified personnel approved by the Engineer.

Any cracks that cannot be removed by grinding 1/4 inch deep shall be identified and reported to the Bureau of Bridges and Structures for further disposition. The cost of removing welded accessories, grinding and inspecting weld areas and grinding cracks will be paid for according to Article 109.04 of the Standard Specifications.

If the Contractor elects to use cantilever forming brackets on the exterior beams or girders, the brackets shall be placed at the same locations as required for the hardwood blocks in Article 503.06(b) of the Standard Specifications. If additional cantilever forming brackets are required, hardwood blocking shall be wedged between the exterior and first interior beam at each of these additional bracket locations.

Plan dimensions and details relative to existing plans are subject to nominal construction variations. The Contractor shall field verify existing dimensions and details affecting new construction and make necessary approved adjustments prior to construction or ordering of materials. Such variations shall not be cause for additional compensation for a change in scope of the work, however, the Contractor will be paid for the quantity actually furnished at the unit price bid for the work.

Bearing seat surfaces shall be constructed or adjusted to the designated elevations within a tolerance of 1/8 inch (0.01 ft.). Adjustment shall be made either by grinding the surface or by shimming the bearings.

The existing structural steel coating contains lead. The Contractor shall take appropriate precautions to deal with the presence of lead on this project.

The concrete for bridge decks finished according to Article 503.16(a) of the Standard Specifications shall be placed and compacted parallel to the skew in uniform increments along centerline of bridge. The machine used for finishing shall be set parallel to the skew for striking off and screeding the concrete.

The Environmental Firm is required to continuously monitor for worker protection and soil contamination at several areas. See Special Provision and Supplemental Specifications for details.

STATION 67+77.53
RE-BUILT 20__ BY
STATE OF ILLINOIS
LOADING HS-20
STRUCTURE NO. 045-0016

NAME PLATE
See Std. 515001

Existing Name Plate shall be cleaned and relocated next to new Name Plate. Cost included with Name Plates.

DESIGNED - DF
CHECKED - BLU
DRAWN - LAM
CHECKED - DF

Cleaning and painting of the existing structural steel shall be as specified in the special provision for "Cleaning and Painting Existing Steel Structures". All beams, bearings and other structural steel within 10 ft (measured along the beam) of either side of deck joints shall be cleaned per Near White Blast - SSPC-SP10. The exterior surfaces and bottom of the bottom flange of the fascia beams shall be cleaned per Power Tool cleaning - Commercial Grade.

Interior beam surfaces where paint failure has occurred as directed by the Engineer shall be cleaned per Power Tool Cleaning - Commercial Grade. It is estimated that these areas equal 2,500 sq. ft. in addition to other areas noted above.

The designated areas cleaned per Near White Blast Cleaning - SSPC-SP10 and per Power Tool Cleaned - Commercial Grade shall be painted according to the requirements of Paint System 1 - OZ/E/U. The color of the final finish coat for all interior steel surfaces shall be Gray, Munsell No 5B 7/1. The color of the final finish coat for the exterior and bottom flange of the fascia beams shall be Interstate Green, Munsell No 7.5G 4/8.

All new structural steel shall be shop painted with an inorganic zinc rich primer per AASHTO M 300, Type 1.

Current Ratings on File for Existing Structure

Inventory: HS 25.0
Operating: HS 38.9
Live Load Restrictions: No

Inventory and Operating Ratings and Live Load Restrictions are for information only. Inventory and Operating Ratings are based on HS loading and configuration. Live Load Restrictions are based on Illinois legal loads and configurations. The Ratings and Live Load Restrictions are not necessarily representative of capacities to support the Contractor's equipment.

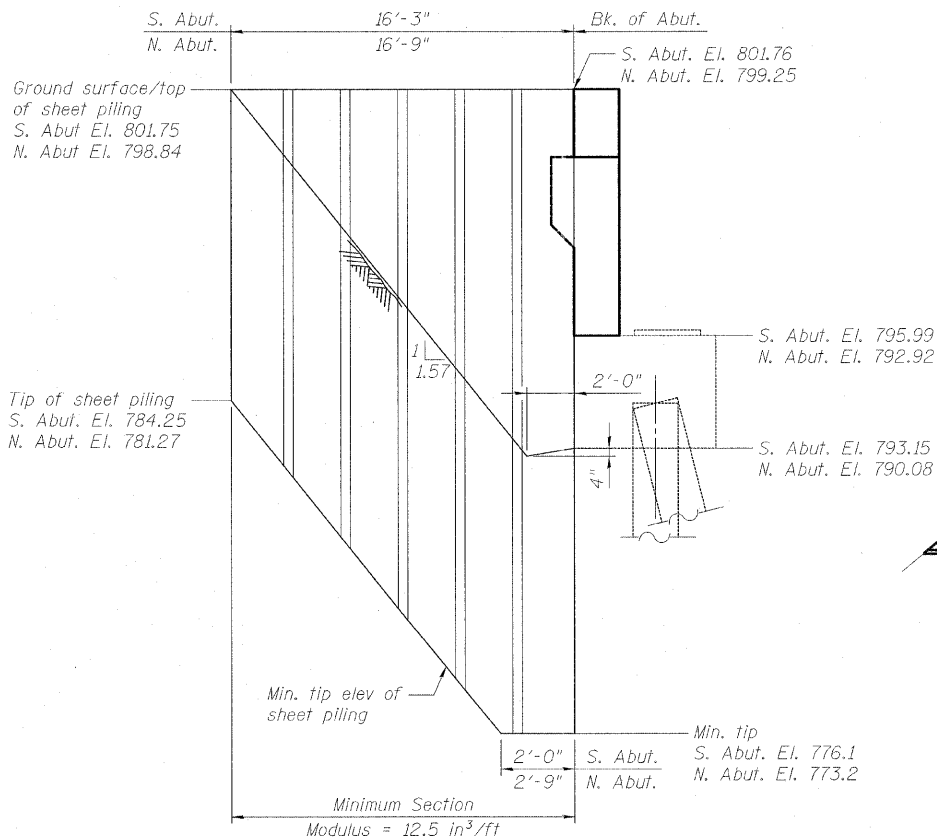

TEMPORARY SHEET PILING

If the Contractor chooses to alter the temporary cantilevered sheet piling design requirements shown on the plans, a design submittal including plan details and calculations will be required for review and acceptance by the Engineer.

INDEX OF SHEETS

S-1	General Plan & Elevation
S-2	General Notes and Total Bill of Material
S-3	Construction Staging
S-4	Steel Railing (Temporary)
S-5	Temporary Concrete Barrier For Stage Construction
S-6	Top of Slab Elevations Layout
S-7	Top of Slab Elevations I
S-8	Top of Slab Elevations II
S-9	Top of Slab Elevations III
S-10	Top of South Approach Slab Elevations
S-11	Top of North Approach Slab Elevations
S-12	Superstructure Plan
S-13	Superstructure Details I
S-14	Superstructure Details II
S-15	Preformed Joint Strip Seal
S-16	Drainage Scupper, DS-12M10
S-17	Bridge Approach Slab Details I
S-18	Bridge Approach Sidewalk & Parapet Details
S-19	Bridge Approach Slab Details II
S-20	Bridge Fence Railing Parapet Mounted
S-21	Framing Plan & Beam Details
S-22	Beam Details
S-23	Abutment Bearing Details
S-24	Pier Bearing Details
S-25	Abutment Removal Details
S-26	Abutment Repair Details
S-27	North Abutment
S-28	North Abutment Wingwall Details
S-29	South Abutment
S-30	South Abutment Wingwall Details
S-31	Abutment Details I
S-32	Abutment Details II
S-33	Pier Repairs & Pier 1 Cap Modification
S-34	Bar Splicer Assembly and Mechanical Splicer Details

TOTAL BILL OF MATERIAL

ITEM	UNIT	SUPER	SUB	TOTAL
Stone Riprap, Class A4	Sq Yd	-	75	75
Filter Fabric	Sq Yd	-	134	134
Concrete Removal	Cu Yd	-	38	38
Removal of Existing Concrete Deck	Each	1	-	1
Protective Shield	Sq Yd	758	-	758
Structure Excavation	Cu Yd	-	439	439
Concrete Structures	Cu Yd	-	140.3	140.3
Concrete Superstructure	Cu Yd	770.1	-	770.1
Bridge Deck Grooving	Sq Yd	1,615	-	1,615
Protective Coat	Sq Yd	2,280	-	2,280
Furnishing and Erecting Structural Steel	Pound	17,570	-	17,570
Stud Shear Connectors	Each	6,504	-	6,504
Cleaning and Painting Structural Steel Location No. 1	L Sum	1	-	1
Reinforcement Bars, Epoxy Coated	Pound	156,420	14,060	170,480
Bar Splicers	Each	1,592	32	1,624
Steel Railing (Temporary)	Foot	306	-	306
Bridge Fence Railing	Foot	611	-	611
Name Plates	Each	1	-	1
Preformed Joint Strip Seal	Foot	196	-	196
Elastomeric Bearing Assembly, Type 1	Each	24	-	24
Elastomeric Bearing Assembly, Type 2	Each	12	-	12
Anchor Bolts, 5/8"	Each	96	-	96
Anchor Bolts, 3/4"	Each	24	-	24
Anchor Bolts, 1"	Each	24	-	24
Concrete Sealer	Sq Ft	-	791	791
Epoxy Crack Injection	Foot	-	10	10
Geocomposite Wall Drain	Sq Yd	-	191	191
Drainage Scuppers, DS-12M10	Each	8	-	8
Porous Granular Embankment, Special	Cu Yd	-	350	350
Structural Steel Removal	Pound	29,160	-	29,160
Removal of Existing Bearings	Each	48	-	48
Containment and Disposal of Lead Paint Cleaning Residue No. 1	L Sum	1	-	1
Structural Repair of Concrete (Depth equal to or less than 5 Inches)	Sq Ft	-	600	600
Drainage System	L Sum	-	1	1
Temporary Sheet Piling	Sq Ft	-	733	733
Jacking Existing Superstructure	L Sum	1	-	1
Pipe Underdrains for Structures, 4"	Foot	-	382	382
Bituminous Coated Aggregate Slopewall, 6"	Sq Yd	-	1,172	1,172

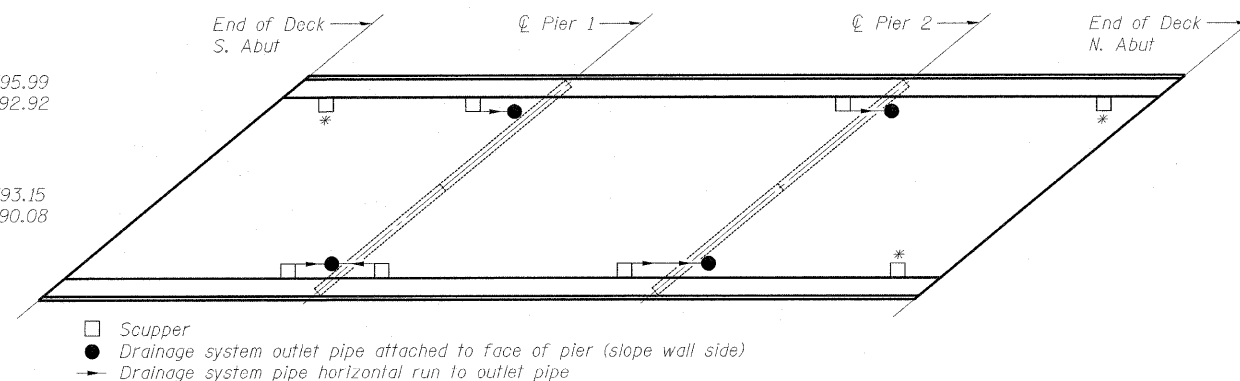

DRAINAGE SYSTEM PLAN

See sheet S-14 for Drainage System Details.
See sheet S-1 for scupper spacing.
* Scuppers are to free fall on slope wall and are not included as part of the Drainage System.

GENERAL NOTES AND
TOTAL BILL OF MATERIAL
STRUCTURE NO. 045-0016

BOWMAN, BARRETT & ASSOCIATES INC.
CONSULTING ENGINEERS
Chicago, Illinois
312.228.0100
www.bbainc.com
Job No. 910

SHEET NO. S-2	F.A.U. RTE. 3887	SECTION R-VB-R	COUNTY KANE	TOTAL SHEETS 83	SHEET NO. 36
S-34 SHEETS	CONTRACT NO. 60C06				
FED. ROAD DIST. NO. 1 ILLINOIS FED. AID PROJECT					