

PROPOSED TYPICAL SECTION - 119th STREET (4)

STA. 20+37.34 TO STA. 20+93.34

STA. 20+49.83 TO STA. 20+73.72 - LAKEWOOD AVENUE (RIGHT OF C)

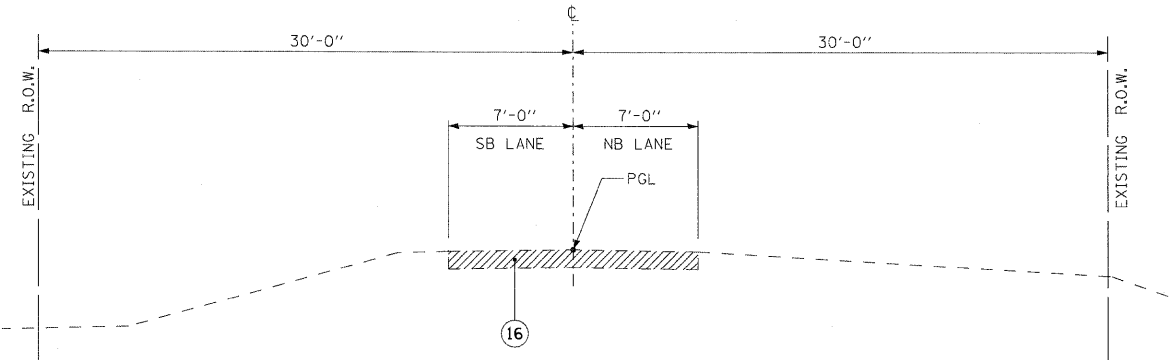

EXISTING TYPICAL SECTION - LAKEWOOD AVENUE

STA 4+54.20 TO STA 5+87.84

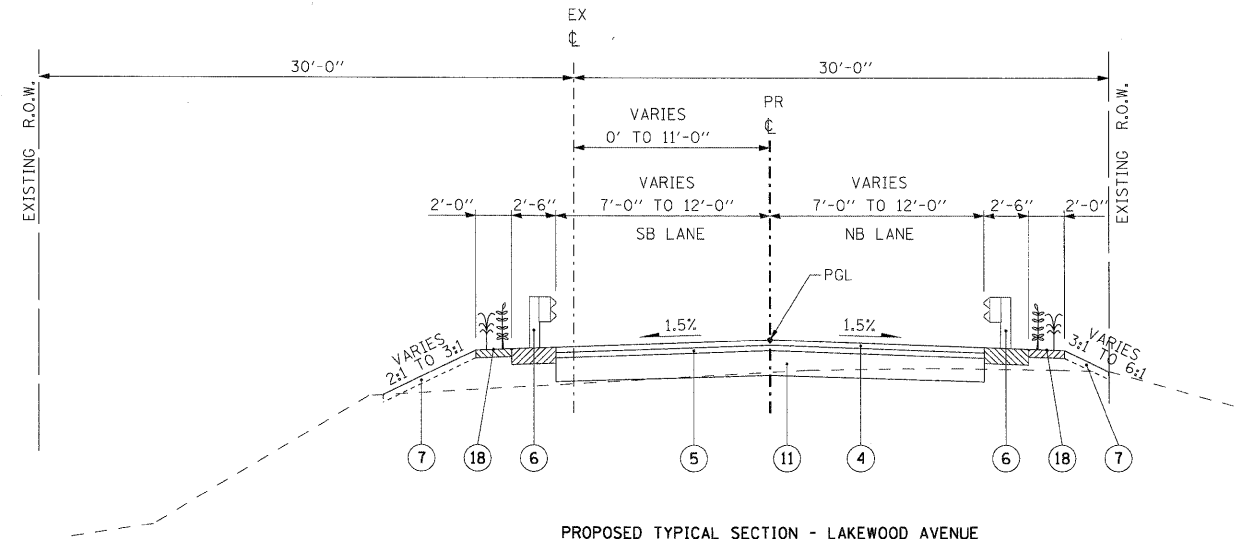

PROPOSED TYPICAL SECTION - LAKEWOOD AVENUE

STA 4+54.20 TO STA 5+67.87

LEGEND

- ① EXISTING BITUMINOUS SURFACE TO BE REMOVED, THICKNESS VARIES 2" TO 4", PAID AS HOT-MIX ASPHALT SURFACE REMOVAL, 3"
- ② EXISTING PAVEMENT, THICKNESS ±10"
- ③ EXISTING AGGREGATE SHOULDERS - See Note 1
- ④ HOT-MIX ASPHALT SURFACE COURSE, MIX D, N70, 1 1/2"
- ⑤ HOT-MIX ASPHALT BINDER COURSE, IL-19.0, N70, 2 1/4"
- ⑥ STEEL PLATE BEAM GUARD RAIL, TYPE A, 6 FOOT POST
- ⑦ COMPOST FURNISH AND PLACE, 4", w/ SEEDING, CLASS 4, AND EROSION CONTROL BLANKET
- ⑧ BRIDGE APPROACH SLAB, PAID AS CONCRETE SUPERSTRUCTURES
- ⑨ PORTLAND CEMENT CONCRETE BASE COURSE WIDENING, 9"
- ⑩ HOT-MIX ASPHALT SHOULDERS, 6"
- ⑪ AGGREGATE SUB-GRADE 12"
- ⑫ RETAINING WALL
- ⑬ STRIP REFLECTIVE CRACK CONTROL TREATMENT
- ⑭ DOWELL BARS, 1"
- ⑮ FURNISHING STEEL PILES HP12X74, w/CAP
- ⑯ EXISTING BITUMINOUS PAVEMENT TO BE REMOVED, PAID AS PAVEMENT REMOVAL
- ⑰ EXISTING GUARDRAIL TO BE REMOVED, PAID AS GUARDRAIL REMOVAL
- ⑱ PERENNIAL PLANT, WOODLAND TYPE, 12" O.C. STAGGERED, WITH COARSE SAND PLACEMENT, 2"

119TH STREET EARTHWORK

LOCATION	EARTH EXCAVATION CU YD	ADJ. EXCAVATION 15% CU YD	REMOVAL AND DISPOSAL OF UNSUITABLE MATERIAL CU YD	FURNISHED EXCAVATION CU YD	EARTHWORK BALANCE WASTE (+) OR SHORTAGE (-) CU YD
STA. 17+53.36 TO 22+39.64	177	150.5	371	483	-332.5

LAKEWOOD STREET EARTHWORK

LOCATION	EARTH EXCAVATION CU YD	ADJ. EXCAVATION 15% CU YD	REMOVAL AND DISPOSAL OF UNSUITABLE MATERIAL CU YD	FURNISHED EXCAVATION CU YD	EARTHWORK BALANCE WASTE (+) OR SHORTAGE (-) CU YD
STA. 17+53.36 TO 22+39.64	2	1.7	48	163	-161.3