

STATE OF ILLINOIS  
DEPARTMENT OF TRANSPORTATION

F.A.S. RTE.	SECTION	COUNTY	TOTAL SHEETS	SHEET NO.
2370*	(78-1)RS-2	PUTNAM	15	1
		ILLINOIS	CONTRACT NO. 66M68	

\* F.A.S. 2370 / OR 26

**INDEX**

- 1 COVER SHEET
- 2 GENERAL NOTES
- 3-5 SUMMARY OF QUANTITIES
- 6-7 TYPICAL SECTIONS
- 8-9 SCHEDULES
- 10 LOCATION MAP
- 11-15 DETAILS

**LIST OF ILLINOIS DOT HIGHWAY STANDARDS**

- 000001-08 STANDARD SYMBOLS, ABBREVIATIONS AND PATTERNS
- 001006 DECIMAL OF AN INCH AND OF A FOOT
- 667101-02 PERMANENT SURVEY MARKERS
- 701101-05 OFF-ROAD OPERATIONS, MULTILANE, 15' TO 24" FROM PAVEMENT EDGE
- 701421-08 LANE CLOSURE, MULTILANE, DAY OPERATIONS ONLY, FOR SPEEDS ≥ 45 MPH TO 55 MPH
- 701426-09 LANE CLOSURE, MULTILANE INTERMITTENT OR MOVING OPERATION, FOR SPEEDS ≥ 45 MPH
- 701456-05 PARTIAL EXIT RAMP CLOSURE FREEWAY/EXPRESSWAY
- 701901-08 TRAFFIC CONTROL DEVICES
- 720001-01 SIGN PANEL MOUNTING DETAILS
- 720006-04 SIGN PANEL ERECTION DETAILS
- 780001-05 TYPICAL PAVEMENT MARKINGS
- 781001-04 TYPICAL APPLICATIONS RAISED REFLECTIVE PAVEMENT MARKERS

# PROPOSED HIGHWAY PLANS

## FAS 2370 / OR 26 (IL 26) SECTION (78-1)RS-2 PROJECT STP-6PM1(392) DESIGNED OVERLAY MILLING & RESURFACING PUTNAM COUNTY

C-93-092-22

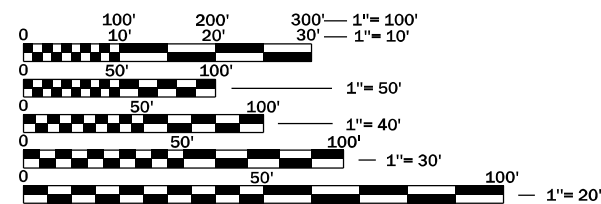
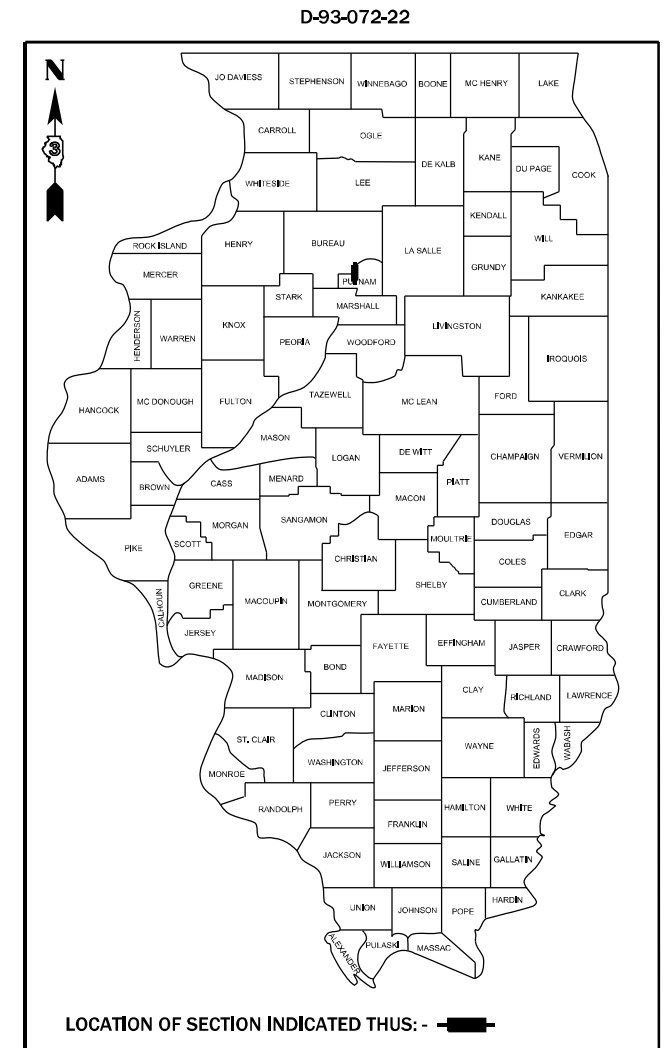

FULL SIZE PLANS HAVE BEEN PREPARED USING STANDARD ENGINEERING SCALES. REDUCED SIZED PLANS WILL NOT CONFORM TO STANDARD SCALES. IN MAKING MEASUREMENTS ON REDUCED PLANS, THE ABOVE SCALES MAY BE USED.

J.U.L.I.E.  
JOINT UTILITY LOCATION INFORMATION FOR EXCAVATION  
1-800-892-0123  
OR 811

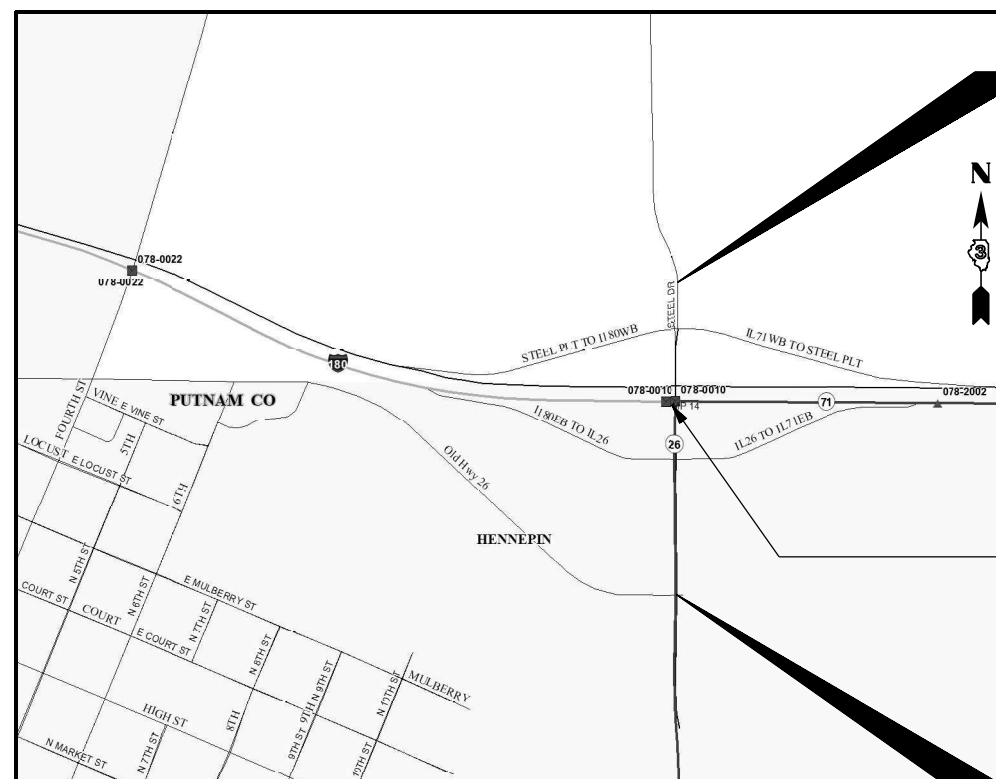

PROJECT ENDS  
STA. 45+12

BRIDGE OMISSION  
S.N. 078-0010  
STA. 41+37.66 -  
STA. 38+62.33

PROJECT BEGINS  
STA. 26+33

GROSS LENGTH = 1879.0 FT. = 0.36 MILE  
NET LENGTH = 1,603.7 FT. = 0.30 MILE

**FUNCTION CLASSIFICATION**  
**MAJOR COLLECTOR**  
2021 ADT = 2600  
P.V. = 86.2% S.U. = 4.2% M.U. = 9.6%

STATE OF ILLINOIS  
DEPARTMENT OF TRANSPORTATION

SUBMITTED June 22, 2022

*Joseph Kannel*  
REGIONAL ENGINEER

August 19, 2022

*Steph M. Smith*  
ENGINEER OF DESIGN AND ENVIRONMENT

August 19, 2022

*Steph M. Smith*  
DIRECTOR OF HIGHWAYS PROJECT IMPLEMENTATION

PRINTED BY THE AUTHORITY  
OF THE STATE OF ILLINOIS

PROJECT ENGINEER: JOSEPH KANNEL, P.E.  
UNIT CHIEF: DARCY CARPENTER  
DISTRICT 3 NO. (815) 434-6131  
CONTRACT NO. 66M68

**GENERAL NOTES**

THE HMA SURFACE OF ALL MAILBOX TURNOUTS, PRIVATE ENTRANCES, COMMERCIAL ENTRANCES, AND SIDE ROADS SHALL BE MADE NEATLY, IN A WORKMANLIKE MANNER, AND SHALL ACCURATELY CONFORM TO THE SHAPES AND DIMENSIONS SHOWN ON THE PLAN DETAILS. IF REQUIRED BY THE ENGINEER, THE CONTRACTOR SHALL SAW CUT THE HMA SURFACE TO CONFORM TO THE SHAPES AND DIMENSIONS SHOWN ON THE PLAN DETAILS. THIS WORK WILL BE INCLUDED IN THE COST OF THE HMA SURFACE.

EXCEPT AS NOTED ON THE PLANS, PAVEMENT GRADES SHOWN ARE AT THE TOP OF PAVEMENT SURFACES.

THE ENGINEER WILL BE THE SOLE JUDGE CONCERNING CURING TIME FOR THE VARIOUS HMA LIFTS.

ALL EXCAVATED MATERIAL, WHICH INCLUDES DIGGING OR GRADING OF ANY SOIL OR FILL MATERIAL, WITH THE EXCEPTION OF AGGREGATE FILLS, MUST BE INCORPORATED WITHIN THE IDOT RIGHT OF WAY.

SHORT TERM PAVEMENT MARKING SHALL BE USED TO OUTLINE EXIT AND ENTRANCE RAMPS FOR THE PRIME COAT APPLICATION AND EACH RESURFACING LIFT.

ON EXISTING PAVEMENT WHICH MAY BE SUPERELEVATED, THE NEW HMA PAVEMENT SHALL BE BUILT WITH THE SAME SUPERELEVATION UNLESS NEW SUPERELEVATION RATES ARE GIVEN ON THE PLANS.

ALL ELEVATIONS REFERRING TO U.S.G.S MEAN SEA LEVEL DATUM.

THE FOLLOWING RATES OF APPLICATION HAVE BEEN USED IN CALCULATING PLAN QUANTITIES:

HMA RESURFACING	112	LBS / SQ YD / IN
SHORT TERM PAVEMENT MARKING	10	FT /100 FT OF APPLICATION
MIX FOR CRACKS, JTS & FLGWYS	0.0003	TONS / SQ YD

MEMBERS OF JULIE KNOWN TO BE WITHIN THE LIMITS OF THE IMPROVEMENT ARE: AMEREN, FRONTIER, MEDIACOM, VILLAGE OF HENNEPIN

NON-MEMBERS OF JULIE KNOWN TO BE WITHIN THE LIMITS OF THE IMPROVEMENT ARE:

THE CONTRACTOR SHALL CONTACT JULIE AT LEAST 48 HOURS PRIOR TO EXCAVATION TO DETERMINE WHICH UTILITIES ARE IN THE AREA.

**COMMITMENTS:**

REMOVED SIGN PANELS SHALL BE RETURNED TO THE IDOT OTTAWA TRAFFIC YARD

**HMA MIXTURE REQUIREMENT TABLE**

LOCATIONS:	ENTIRE PROJECT	ENTIRE PROJECT	ENTIRE PROJECT	EINTIRE PROJECT	EINTIRE PROJECT
MIXTURE USE(S):	HMA BINDER	HMA SURFACE	HMA SHOULDER BOTTOM LIFT	HMA SHOULDER TOP LIFT	HMA INCIDENTAL
BINDER GRADE (PG):	SBS PG 70-28	SBS PG 70-28	PG 64-22	PG 64-22	PG 64-22
DESIGN AIR VOIDS:	4.0% @ N70	4.0% @ N70	4.0% @ N50	4.0% @ N50	4.0% @ N50
MIXTURE COMPOSITION: (MIXTURE GRADATION)	IL 19.0	IL 9.5	IL 19.0	IL 9.5	IL 9.5
FRICTION AGGREGATE:		MIXTURE C		MIXTURE C	MIXTURE C
MIXTURE WEIGHT:	112.0 LB/SY/IN	112.0 LB/SY/IN	112.0 LB/SY/IN	112.0 LB/SY/IN	112.0 LB/SY/IN
QUALITY MANAGEMENT PROGRAM:	QCQA	QCQA	QCQA	QCQA	QCQA
SUBLOT SIZE:	NA	NA	NA	NA	NA
DENSITY TEST METHOD:	CORES/NUCLEAR	CORES/NUCLEAR	CORES/NUCLEAR	CORES/NUCLEAR	SATISFACTION OF ENGINEER
MATERIAL TRANSFER DEVICE (REQUIRED)	NO	NO	NO	NO	NO

STATE OF ILLINOIS  
DEPARTMENT OF TRANSPORTATION  
DISTRICT THREE  
AS BUILT INFORMATION

\_\_\_\_\_  
SUPERVISING CONSTRUCTION FIELD ENGINEER

\_\_\_\_\_  
RESIDENT ENGINEER / TECHNICIAN

START & END DATES  
OF CONSTRUCTION:

INSPECTORS:

STATE OF ILLINOIS  
DEPARTMENT OF TRANSPORTATION  
DISTRICT THREE

PREPARED BY: \_\_\_\_\_  
DISTRICT STUDIES & PLANS ENGINEER

DATE: \_\_\_\_\_

EXAMINED BY: \_\_\_\_\_  
DISTRICT CONSTRUCTION ENGINEER

\_\_\_\_\_  
DISTRICT MATERIALS ENGINEER

\_\_\_\_\_  
DISTRICT OPERATIONS ENGINEER

\* F.A.S. 2370 / OR 26

MODEL: Default  
FILE: \\na11e-pw\idoc\paw\benefy.com\PIV\DOT\Documents\IDOT\Office\District 3\Project\ID366M68\CADD\DATA\ID366M68-zht-cover.dgn

USER NAME = Anthony.Grunstad	DESIGNED - _____	REVISED - _____
	DRAWN - _____	REVISED - _____
PLOT SCALE = 100,0000' / in.	CHECKED - _____	REVISED - _____
PLOT DATE = 6/13/2022	DATE - _____	REVISED - _____

**STATE OF ILLINOIS  
DEPARTMENT OF TRANSPORTATION**

**GENERAL NOTES**

SCALE: \_\_\_\_\_ SHEET \_\_\_ OF \_\_\_ SHEETS STA. \_\_\_\_\_ TO STA. \_\_\_\_\_

F.A.S. RTE.	SECTION	COUNTY	TOTAL SHEETS	SHEET NO.
2370*	(78-1)RS-2	PUTNAM	15	2
CONTRACT NO. 66M68				
ILLINOIS FED. AID PROJECT				

CONSTR. CODE
80%FED/20%STATE
FAS 2370/OR 26
ROADWAY
0005
RURAL

CODE NO.	ITEM	UNIT	TOTAL QUANTITY	
40600290	BITUMINOUS MATERIALS (TACK COAT)	POUND	11902	11902
40600370	LONGITUDINAL JOINT SEALANT	FOOT	7416	7416
40600400	MIXTURE FOR CRACKS, JOINTS, AND FLANGEWAYS	TON	5	5
40600990	TEMPORARY RAMP	SQ YD	505	505
40603235	POLYMERIZED HOT-MIX ASPHALT BINDER COURSE, IL-19.0, N70	TON	1665	1665
40604152	POLYMERIZED HOT-MIX ASPHALT SURFACE COJRSE, IL-9.5, MIX "C", N70	TON	1110	1110
40800050	INCIDENTAL HOT-MIX ASPHALT SURFACING	TON	188	188
44000164	HOT-MIX ASPHALT SURFACE REMOVAL, 3 3/4"	SQ YD	16355	16355
48203100	HOT-MIX ASPHALT SHOULDERS	TON	660	660
67100100	MOBILIZATION	L SUM	1	1
70100310	TRAFFIC CONTROL AND PROTECTION, STANDARD 701421	L SUM	1	1
70100825	TRAFFIC CONTROL AND PROTECTION, STANDARD 701456	L SUM	1	1
70300100	SHORT TERM PAVEMENT MARKING	FOOT	576	576
70300150	SHORT TERM PAVEMENT MARKING REMOVAL	SQ FT	95	95

MODEL: Default  
 FILE NAME: p:\project-pw-beadley.com\PIV\DOT\Documents\DOT Office\Dir\dir: 3\Project\036668\CADD\036668-2ht-cover.dgn

\* F.A.S. 2370 / OR 26

USER NAME = Timothy.Pletsch	DESIGNED - _____	REVISED - _____
	DRAWN - _____	REVISED - _____
PLOT SCALE = 100,0000' / in.	CHECKED - _____	REVISED - _____
PLOT DATE = 6/13/2022	DATE - _____	REVISED - _____

**STATE OF ILLINOIS  
DEPARTMENT OF TRANSPORTATION**

**SUMMARY OF QUANTITIES**

SCALE: \_\_\_\_\_ SHEET \_\_\_\_ OF \_\_\_\_ SHEETS STA. \_\_\_\_\_ TO STA. \_\_\_\_\_

F.A.S. RTE.	SECTION	COUNTY	TOTAL SHEETS	SHEET NO.
2370*	(78-1)RS-2	PUTNAM	15	3
CONTRACT NO. 66M68			ILLINOIS FED. AID PROJECT	

CONSTR. CODE  
80%FED/20%STATE  
FAS 2370/OR 26

CODE NO.	ITEM	UNIT	TOTAL QUANTITY	ROADWAY	
				0005	RURAL
* 72000300	SIGN PANEL - TYPE 3	SQ FT	191	191	
* 72400330	REMOVE SIGN PANEL - TYPE 3	SQ FT	220	220	
* 78004600	PREFORMED PLASTIC PAVEMENT MARKING, TYPE D - LETTERS AND SYMBOLS	SQ FT	93.6	93.6	
* 78004640	PREFORMED PLASTIC PAVEMENT MARKING, TYPE D - LINE 8"	FOOT	470	470	
* 78004720	PREFORMED PLASTIC PAVEMENT MARKING, TYPE D - LINE 24"	FOOT	108	108	
* 78009004	MODIFIED URETHANE PAVEMENT MARKING - LINE 4"	FOOT	14934	14934	
* 78009006	MODIFIED URETHANE PAVEMENT MARKING - LINE 6"	FOOT	60	60	
* 78009008	MODIFIED URETHANE PAVEMENT MARKING - LINE 8"	FOOT	1498	1498	
* 78009012	MODIFIED URETHANE PAVEMENT MARKING - LINE 12"	FOOT	734	734	
* 78011000	GROOVING FOR RECESSED PAVEMENT MARKING, LETTERS AND SYMBOLS	SQ FT	93.6	93.6	
* 78011025	GROOVING FOR RECESSED PAVEMENT MARKING 5"	FOOT	7467	7467	
* 78011035	GROOVING FOR RECESSED PAVEMENT MARKING 7"	FOOT	30	30	
* 78011045	GROOVING FOR RECESSED PAVEMENT MARKING 9"	FOOT	1219	1219	
* 78011065	GROOVING FOR RECESSED PAVEMENT MARKING 13"	FOOT	367	367	

\*= SPECIALTY ITEM

MODEL: Default  
FILE NAME: p:\project-aw-beadley.com\PIV\DOT\Documents\DOT Office\Dir\dir: 3\Project\0366468\CAD\DATA\0366468-2ht-cover.dgn

\* F.A.S. 2370 / OR 26

USER NAME = Timothy.Pletsch	DESIGNED - _____	REVISED - _____	<b>STATE OF ILLINOIS DEPARTMENT OF TRANSPORTATION</b>	<b>SUMMARY OF QUANTITIES</b>			F.A.S. RTE.	SECTION	COUNTY	TOTAL SHEETS	SHEET NO.
PLOT SCALE = 100,0000' / in.	CHECKED - _____	REVISED - _____					2370*	(78-1)RS-2	PUTNAM	15	4
PLOT DATE = 6/13/2022	DATE - _____	REVISED - _____		SCALE: _____ SHEET ____ OF ____ SHEETS STA. _____ TO STA. _____			CONTRACT NO. 66M68				
							ILLINOIS FED. AID PROJECT				

CONSTR. CODE  
80%FED/20%STATE  
FAS 2370/OR 26

CODE NO.	ITEM	UNIT	TOTAL QUANTITY	CONSTR. CODE	
				ROADWAY	RURAL
				0005	
* 78011125	GROOVING FOR RECESSED PAVEMENT MARKING 25"	FOOT	108		108
* 78100100	RAISED REFLECTIVE PAVEMENT MARKER	EACH	133		133
* 78200020	CURB REFLECTORS	EACH	23		23
78300200	RAISED REFLECTIVE PAVEMENT MARKER REMOVAL	EACH	132		132
X0326649	LINEAR DELINEATOR PANELS, 6 INCH	EACH	8		8
X0327809	LINEAR DELINEATOR PANELS, 4 INCH	EACH	4		4
X4401198	HOT-MIX ASPHALT SURFACE REMOVAL, VARIABLE DEPTH	SQ YD	1277		1277
Z0030850	TEMPORARY INFORMATION SIGNING	SQ FT	61		61

\*= SPECIALTY ITEM

MODEL: Default  
 FILE NAME: p:\u0000\paw\_bentley.com\P\I\DOT\Documents\DOT Office\Dir\dir: 3\Project\0366468\CAD\Date: D366468-4ht-cover.dgn

\* F.A.S. 2370 / OR 26

USER NAME = Timothy.Pletsch PLOT SCALE = 100,0000' / in. PLOT DATE = 6/13/2022	DESIGNED - _____ DRAWN - _____ CHECKED - _____ DATE - _____	REVISED - _____ REVISED - _____ REVISED - _____ REVISED - _____	<b>STATE OF ILLINOIS DEPARTMENT OF TRANSPORTATION</b>	<b>SUMMARY OF QUANTITIES</b>	SCALE: _____ SHEET ____ OF ____ SHEETS STA. _____ TO STA. _____	<table border="1"> <tr> <th>F.A.S. RTE.</th> <th>SECTION</th> <th>COUNTY</th> <th>TOTAL SHEETS</th> <th>SHEET NO.</th> </tr> <tr> <td>2370*</td> <td>(78-1)RS-2</td> <td>PUTNAM</td> <td>15</td> <td>5</td> </tr> <tr> <td colspan="5" style="text-align: right;">CONTRACT NO. 66M68</td> </tr> </table>	F.A.S. RTE.	SECTION	COUNTY	TOTAL SHEETS	SHEET NO.	2370*	(78-1)RS-2	PUTNAM	15	5	CONTRACT NO. 66M68				
F.A.S. RTE.	SECTION	COUNTY	TOTAL SHEETS	SHEET NO.																	
2370*	(78-1)RS-2	PUTNAM	15	5																	
CONTRACT NO. 66M68																					

ILLINOIS FED. AID PROJECT

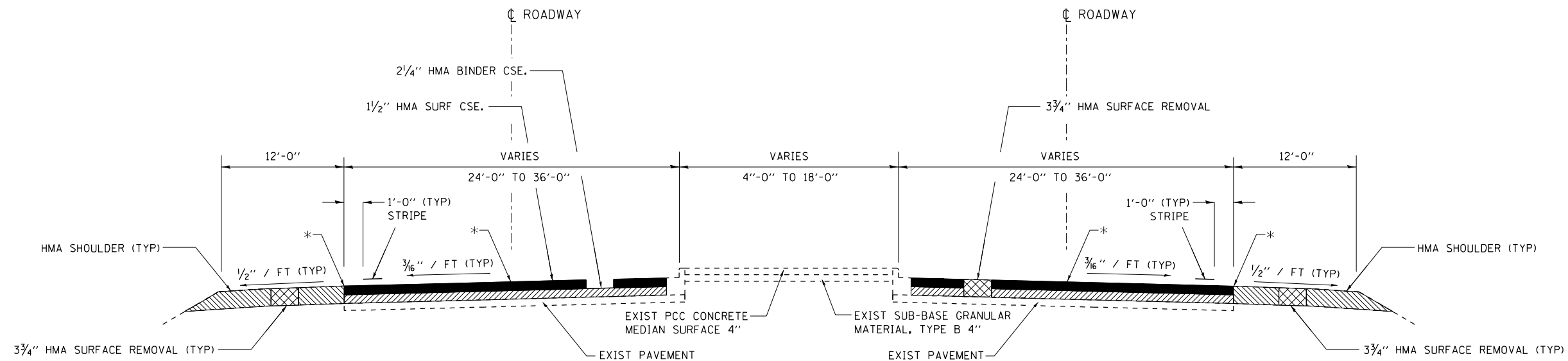

**TYPICAL SECTION**

STA. 45+12  
TO  
STA. 41+37.66

\* LONGITUDINAL JOINT SEAL  
AT THESE LOCATIONS UNDER  
SURFACE LIFT.

OMISSION S.N. 078-0010  
STA. 38+62.33 - 41+37.66

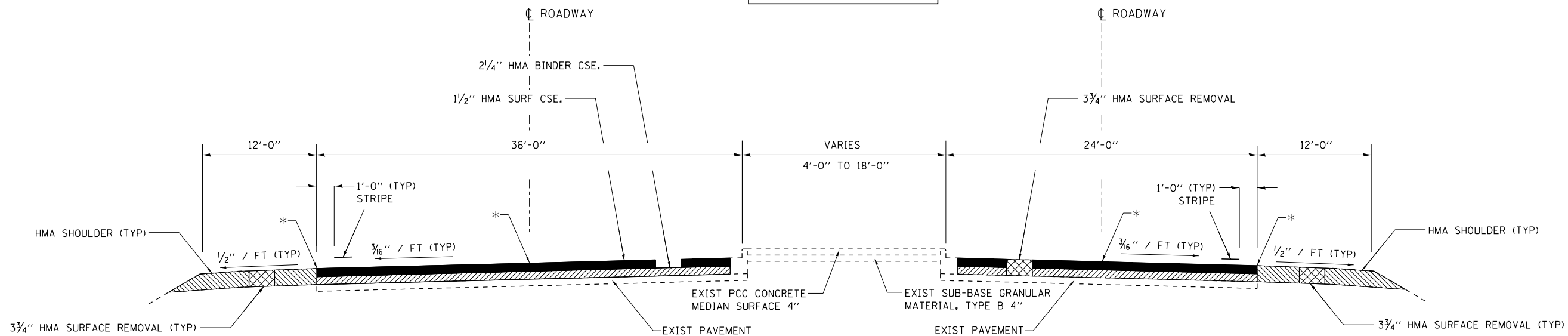

**TYPICAL SECTION**

STA. 38+62.33  
TO  
STA. 36+15

STATE OF ILLINOIS  
DEPARTMENT OF TRANSPORTATION

TYPICAL SECTIONS

SCALE: \_\_\_\_\_ SHEET \_\_\_\_ OF \_\_\_\_ SHEETS STA. \_\_\_\_\_ TO STA. \_\_\_\_\_

\* F.A.S. 2370 / OR 26

USER NAME = Timothy.Pletsch	DESIGNED - T.G.	REVISED - _____
	DRAWN - T.G.	REVISED - _____
PLOT SCALE = 100,0000' / in.	CHECKED - _____	REVISED - _____
PLOT DATE = 6/15/2022	DATE - 05/11/22	REVISED - _____

F.A.S. RTE.	SECTION	COUNTY	TOTAL SHEETS	SHEET NO.
2370*	(78-1)RS-2	PUTNAM	15	6
CONTRACT NO. 66M68				
ILLINOIS FED. AID PROJECT				

MODEL: Default  
FILE: \\nafe\p\subsect-pw-bead\p\com\p\w\dot\Documents\DOT Office\Drawings\3\Project\10366468\CADD\Drawings\3\66M68-shr-typical.dgn

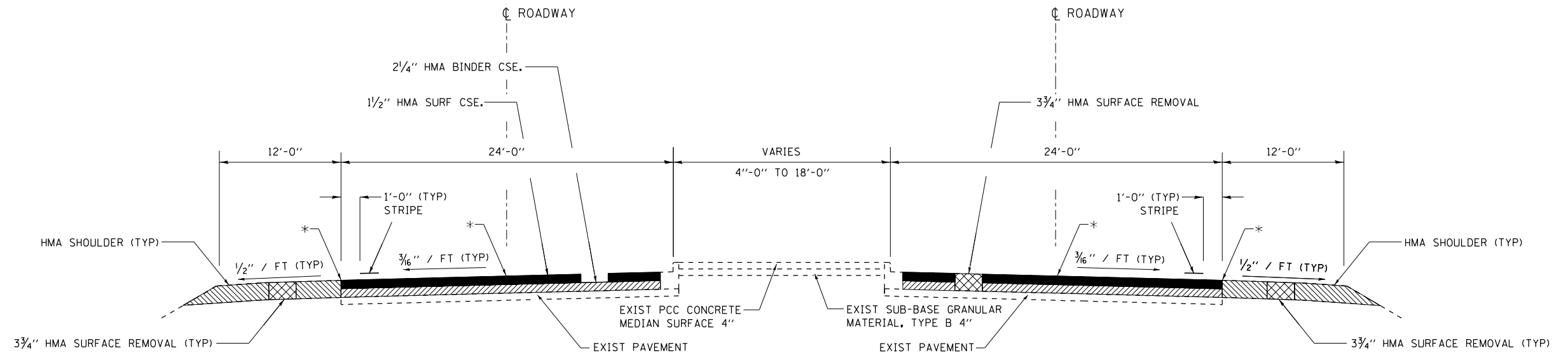

**TYPICAL SECTION**

STA. 36+15  
TO  
STA. 28+49

OMISSION S.N. 078-0010  
STA. 38+62.33 - 41+37.66

\* LONGITUDINAL JOINT SEAL  
AT THESE LOCATIONS UNDER  
SURFACE LIFT.

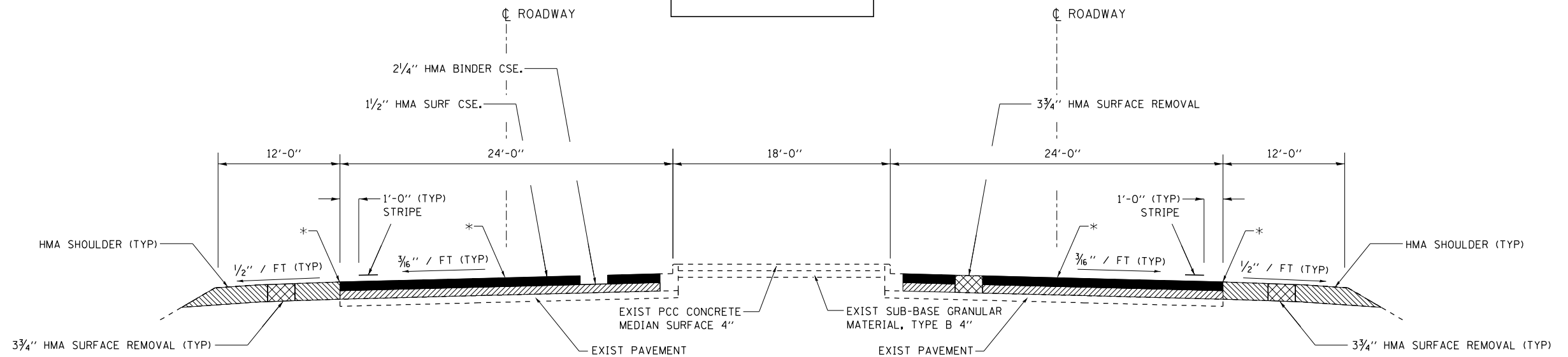

**TYPICAL SECTION**

STA. 28+49  
TO  
STA. 26+33

MODEL: Default  
FILE: \\naufc-pw\pub\sect-pw-bead\p\p\DOT\Documents\DOT\Office\Dir\ref: 3\Project\10366468\CADD\10366468-2\typical.dgn

USER NAME = Timothy.Pletsch	DESIGNED - T.G.	REVISED - _____
	DRAWN - T.G.	REVISED - _____
PLOT SCALE = 100,0000' / in.	CHECKED - _____	REVISED - _____
PLOT DATE = 6/15/2022	DATE - 05/11/22	REVISED - _____

**STATE OF ILLINOIS  
DEPARTMENT OF TRANSPORTATION**

<b>TYPICAL SECTIONS</b>	
SCALE: _____	SHEET _____ OF _____ SHEETS
STA. _____	TO STA. _____

\* F.A.S. 2370 / OR 26

F.A.S. RTE. 2370*	SECTION (78-1)RS-2	COUNTY PUTNAM	TOTAL SHEETS 15	SHEET NO. 7
			CONTRACT NO. 66M68	
ILLINOIS FED. AID PROJECT				





**PAVEMENT MARKING SCHEDULE**

LOCATION			LENGTH	MOD URETHANE PAVEMENT MARKING		MOD URETHANE PVMT MRKG	MOD URETHANE PVMT MRKG	MOD URETHANE PVMT MRKG	MOD URETHANE PVMT MRKG	PREFORMED PVMT MRKG TY D CONTRAST BLK/WH/BLK	PREFORMED PLASTIC PVMT MRKG TY D	PREFORMED PLASTIC PVMT MRKG TY D LETTERS	GROOVING FOR RECESSED PVMT MRKG	GROOVING FOR RECESSED PVMT MRKG	GROOVING FOR RECESSED PVMT MRKG	GROOVING FOR RECESSED PVMT MRKG	GROOVING FOR RECESSED PVMT MRKG	GROOVING FOR RECESSED PVMT MRKG	RAISED REFLECT PVMT MARK	RAISED REFLECT PVMT MARK	RAISED REFLECT PVMT MARK	SHORT TERM PVMT MARK	SHORT TERM PVMT MARK
				4"	6"	8"	12"	8"	24"	& SYMB	5"	7"	9"	13"	25"	LET & SYM	REM	2 WAY YEL	1 WAY WH				
STA.	TO	STA.		WHITE FOOT	YELLOW FOOT	YELLOW FOOT	WHITE FOOT	WHITE FOOT	WHITE FOOT	WHITE FOOT	SQ FT	FOOT	FOOT	FOOT	FOOT	FOOT	FOOT	SQ FT	EACH	EACH	EACH	FOOT	SQ FT
26+33		45+12	1879	5824	5840					470		62.4	5832		470			62.4	96	73	23	282	47
		OLD IL 26	130	720		60	342	192				30	360	30	171	96	30		8	2	6	78	13
		RAMP D	224	596	456		780	392			33	31.2	526		390	196	33	31.2	9	3	6	134	22
		RAMP C	126	324	266								295						7	2	5	38	6
		RAMP A	67	286	152								219						6	1	5	20	3
		RAMP B	81	308	162		376	150			45		235		188	75	45		7	1	6	24	4
<b>TOTAL</b>				<b>8058</b>	<b>6876</b>	<b>60</b>	<b>1498</b>	<b>734</b>	<b>470</b>	<b>108</b>	<b>93.6</b>	<b>7467</b>	<b>30</b>	<b>1219</b>	<b>367</b>	<b>108</b>	<b>93.6</b>	<b>133</b>	<b>82</b>	<b>51</b>	<b>576</b>	<b>95</b>	

PAVEMENT MARKING INCLUDES BRIDGE OMISSION  
 NOTE: ALL MODIFIED URETHANE PAVEMENT MARKING QUANTITIES REPRESENT 2 APPLICATIONS; THE SECOND OF WHICH IS TO BE APPLIED NO SOONER THAN 10 DAYS AFTER THE FIRST APPLICATION.

\* FAS 2370 / OR 26

FILE NAME =	USER NAME = Timothy.Pletsch	DESIGNED - _____	REVISED - _____	<b>STATE OF ILLINOIS DEPARTMENT OF TRANSPORTATION</b>	<b>SCHEDULES</b>			F.A.S. RTE.	SECTION	COUNTY	TOTAL SHEETS	SHEET NO.
pw:\idot\pw.bentley.com\PWIDOT\Documents\IDOT Office\District 3\Projects\0366M68\CADData\0366M68-sh-schedule.dwg	DRAWN - _____	REVISED - _____	2370*					(78-1)RS-2	PUTNAM	15	9	
PLOT SCALE = 100,0000' / in.	CHECKED - _____	REVISED - _____	CONTRACT NO. 66M68									
Default	DATE - _____	REVISED - _____	SCALE: _____					SHEET _____ OF _____ SHEETS	STA. _____ TO STA. _____	ILLINOIS FED. AID PROJECT		

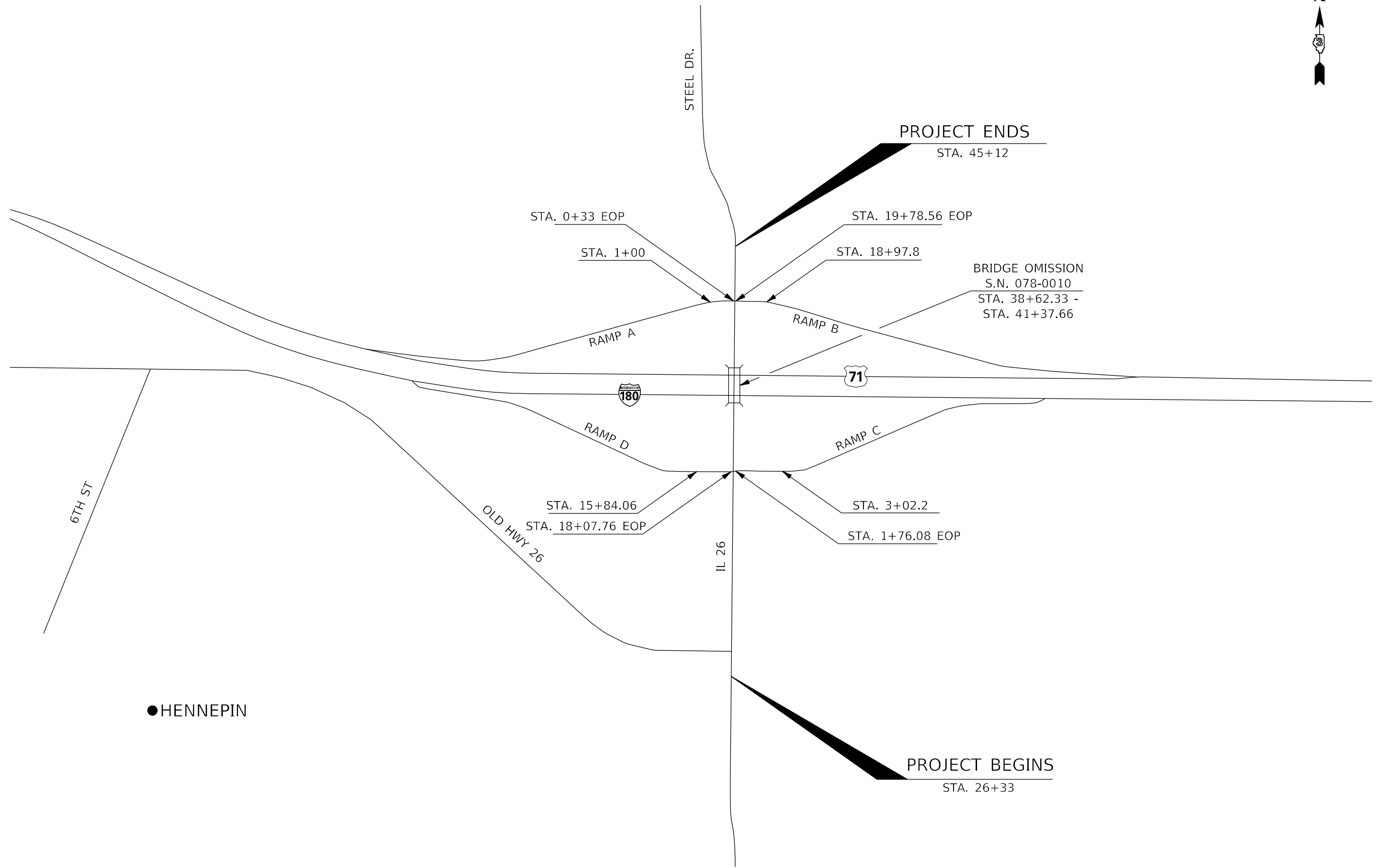

MODEL: Default  
 FILE NAME: p:\project-aw-beadley.com\PIV\DOT\Documents\DOT Office\Dir\rdt\_3\Project\0366668\CAD\Drawn\0366668-2ht-line\_d8aynam.dgn

\* F.A.S. 2370 / OR 26

USER NAME = Anthony.Grunstad DESIGNED - T.G. DRAWN - T.G. PLOT SCALE = 100,0000' / in. CHECKED - _____ PLOT DATE = 6/13/2022 DATE - 05/04/22				REVISED - _____ REVISED - _____ REVISED - _____ REVISED - _____				<b>STATE OF ILLINOIS DEPARTMENT OF TRANSPORTATION</b>		<b>LOCATION MAP</b>				F.A.S. RTE. 2370* SECTION (78-1)RS-2 COUNTY PUTNAM TOTAL SHEETS 15 SHEET NO. 10 CONTRACT NO. 66M68 ILLINOIS FED. AID PROJECT	
SCALE: _____						SHEET _____ OF _____ SHEETS		STA. _____ TO STA. _____							

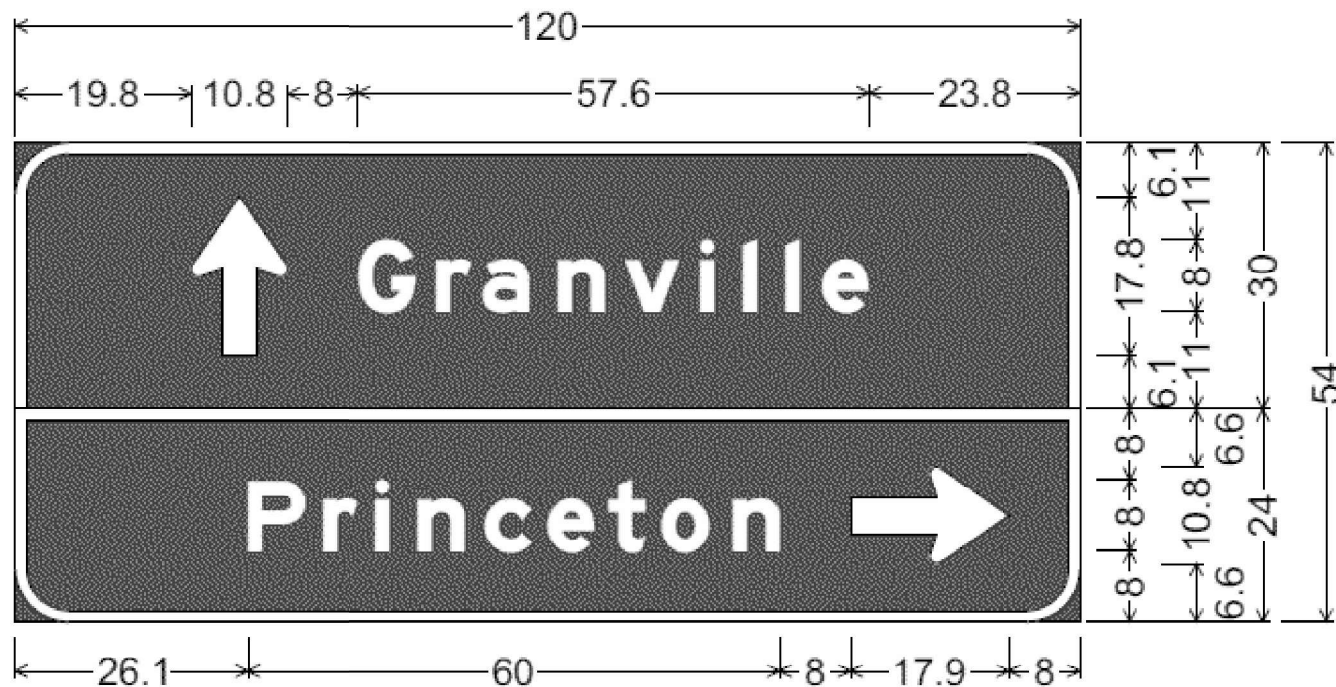

6.0" Radius, 1.3" Border, White on Green;  
 Standard Arrow Custom 17.9" X 10.9" 90°;  
 "Granville", E Mod 2K;

6.0" Radius, 1.3" Border, White on Green;  
 "Princeton", E Mod 2K;  
 Standard Arrow Custom 17.9" X 10.9" 0°;

Table of distances between letter and object lefts

19.8	↑	G	r	a	n	v	i	l	l	e	23.8
18.8		8.9	5.2	8.5	7.6	8.5	4.8	4.8	4.1	5.2	
26.1	P	r	i	n	c	e	t	o	n	→	8.0
8.4		5.9	4.8	7.8	7.0	6.9	6.0	7.9	13.3	17.9	

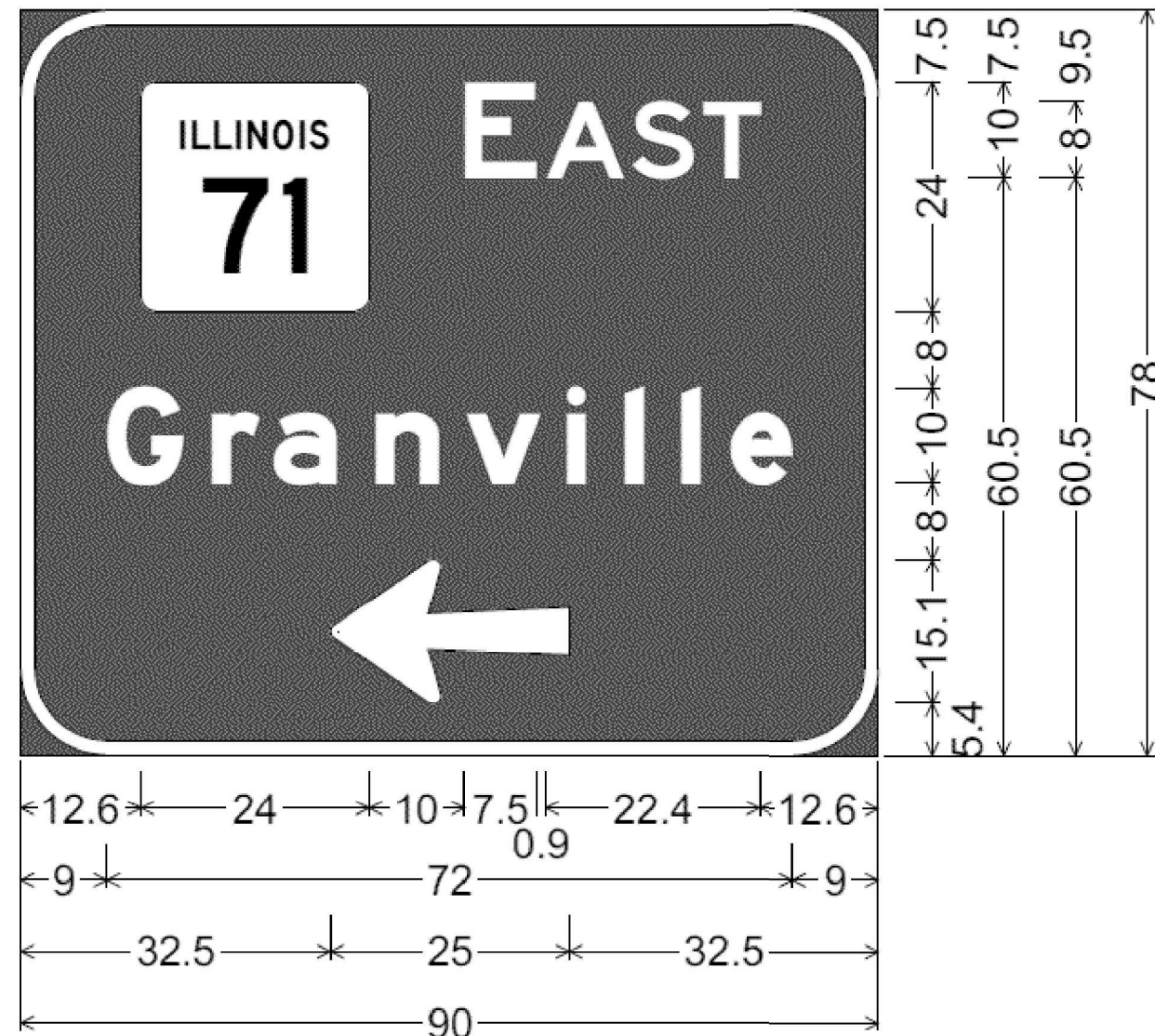

9.0" Radius, 1.5" Border, White on Green;  
 "EAST", E 2K; "Granville", E Mod 2K;  
 Arrow 80 - 25.0" 180°;

Table of distances between letter and object lefts

12.6	ILLINOIS	71	E	A	S	T	12.6			
	34.0	8.4	9.1	7.3	6.0					
9.0	G	r	a	n	v	i	l	l	e	9.0
	11.1	6.5	10.6	9.5	10.6	6.0	6.0	5.1	6.6	
32.5	←	32.5								
	25.0									

MODEL: Default  
 FILE: M:\MIS\_P\Subsect-new-beadefy.com\PIV\DOT\Documents\DOT\_Offices\Dir\rdet\_3\Project\10366468\CADD\Drawn\3\Project\10366468-ah-detailed.dgn

USER NAME = Anthony.Grunstad	DESIGNED -	REVISED -
DRAWN -	REVISOR -	
PLOT SCALE = 80,0000 */ in.	CHECKED -	REVISED -
PLOT DATE = 6/13/2022	DATE -	REVISED -

STATE OF ILLINOIS  
 DEPARTMENT OF TRANSPORTATION

SIGNAGE DETAILS

SCALE: SHEET OF SHEETS STA. TO STA.

\* F.A.S. 2370 / OR 26

F.A.S. RTE. 2370*	SECTION (78-1)RS-2	COUNTY PUTNAM	TOTAL SHEETS 15	SHEET NO. 11
CONTRACT NO. 66M68			ILLINOIS FED. AID PROJECT	

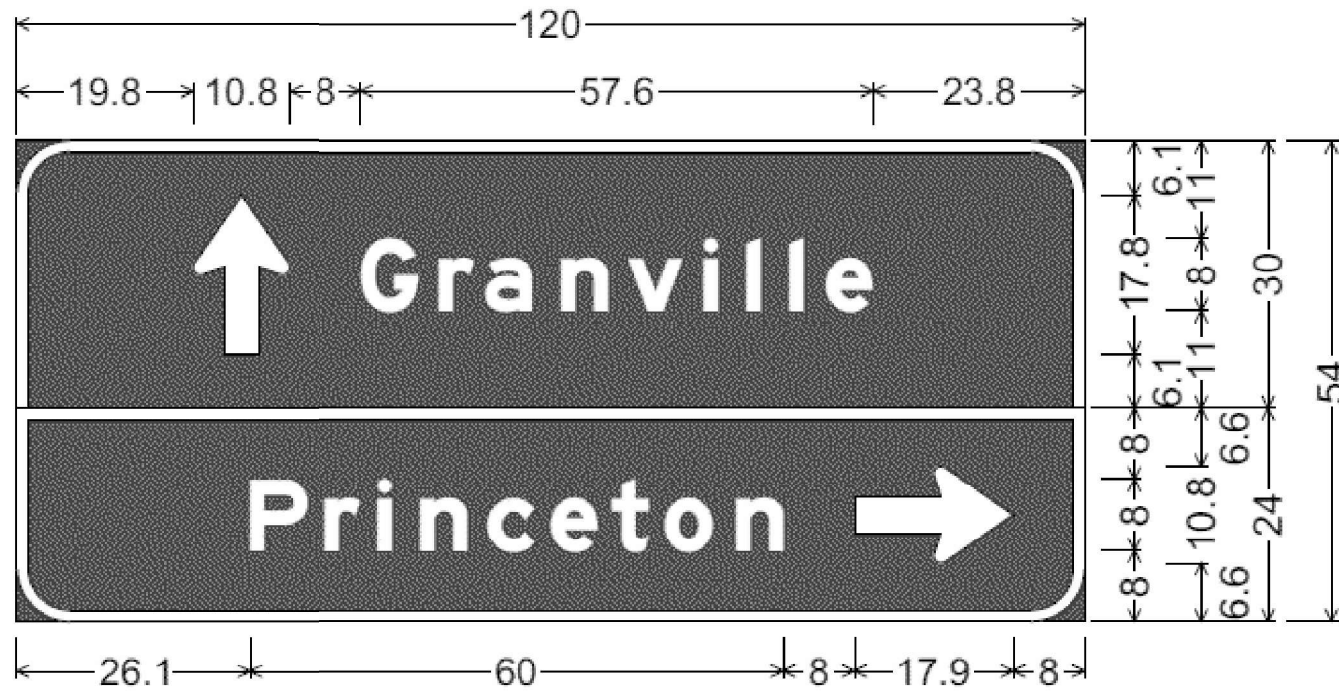

6.0" Radius, 1.3" Border, White on Green;  
 Standard Arrow Custom 17.9" X 10.9" 90°;  
 "Granville", E Mod 2K;

6.0" Radius, 1.3" Border, White on Green;  
 "Princeton", E Mod 2K;  
 Standard Arrow Custom 17.9" X 10.9" 0°;

Table of distances between letter and object lefts

19.8	↑	G	r	a	n	v	i	l	l	e	23.8
18.8		8.9	5.2	8.5	7.6	8.5	4.8	4.8	4.1	5.2	
26.1	P	r	i	n	c	e	t	o	n	→	8.0
8.4		5.9	4.8	7.8	7.0	6.9	6.0	7.9	13.3	17.9	

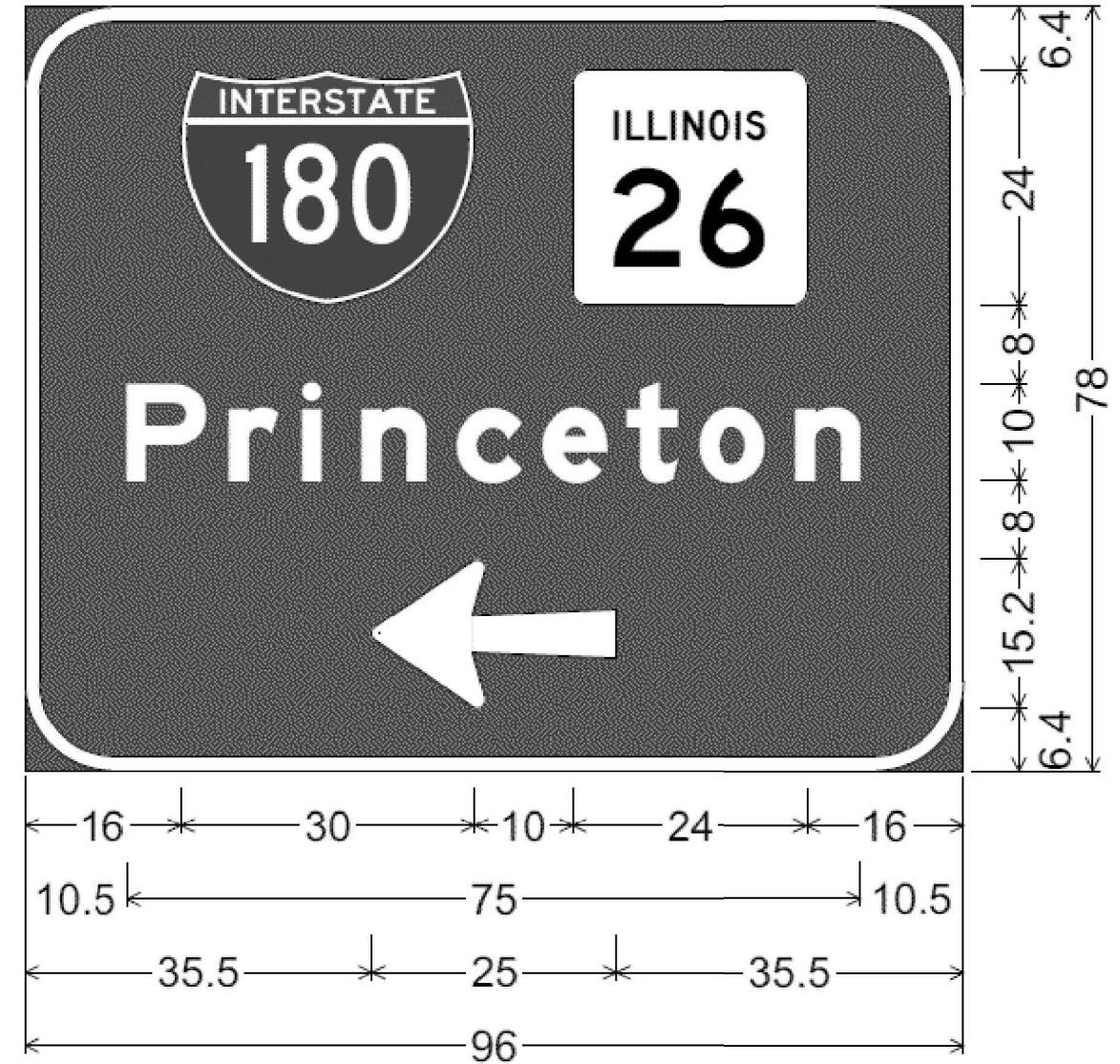

9.0" Radius, 1.5" Border, White on Green;  
 "Princeton", E Mod 2K;  
 Arrow 80 - 25.0" 180°;

Table of distances between letter and object lefts

16.0	180	26	16.0							
40.0	24.0									
10.5	P	r	i	n	c	e	t	o	n	10.5
10.5		7.4	6.0	9.7	8.8	8.6	7.5	9.9	6.6	
35.5	←	35.5								
25.0										

MODEL: Default  
 FILE: M:\MIS\_Plan\Subsect-cw-beadley.com\PIV\DOT\Documents\DOT\_Offices\Dir\rdet\_3\Project\10366468\CADD\Draws\10366468-2hr-detail.dgn

USER NAME = Anthony.Grunstad	DESIGNED -	REVISED -
DRAWN -	REVISIONS -	
PLOT SCALE = 80,0000 */ in.	CHECKED -	REVISED -
PLOT DATE = 6/13/2022	DATE -	REVISED -

STATE OF ILLINOIS  
 DEPARTMENT OF TRANSPORTATION

SIGNAGE DETAILS

SCALE: SHEET OF SHEETS STA. TO STA.

\* F.A.S. 2370 / OR 26

F.A.S. RTE. 2370*	SECTION (78-1)RS-2	COUNTY PUTNAM	TOTAL SHEETS 15	SHEET NO. 12
CONTRACT NO. 66M68			ILLINOIS FED. AID PROJECT	

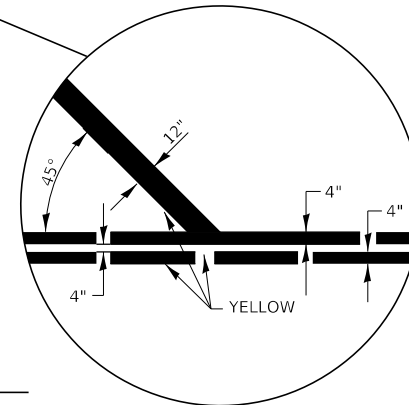
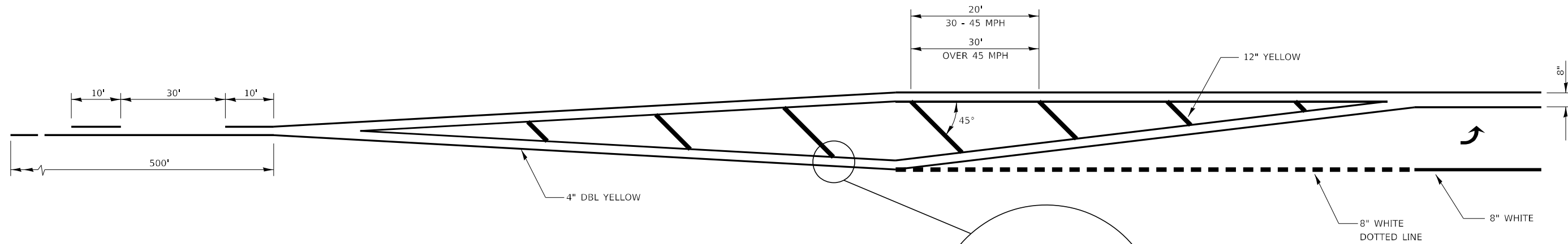

**LEFT TURN LANE WITH APPROACH MEDIAN**

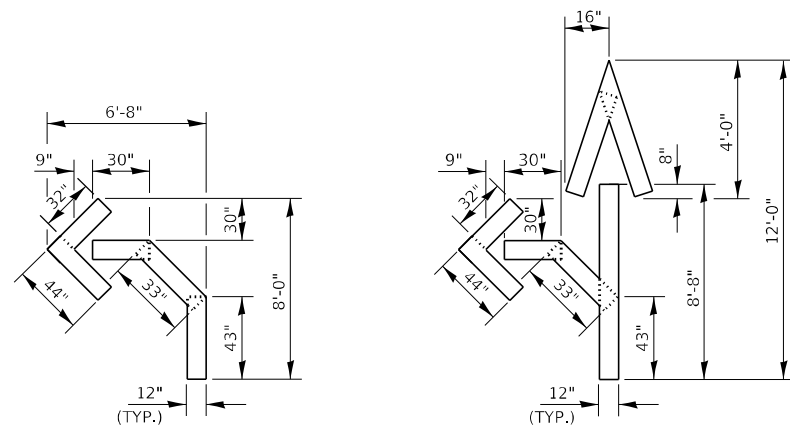

QUANTITY  
12" LINE = 16 LIN FT  
OR 4" LINE = 48 LIN FT

QUANTITY  
12" LINE = 29 LIN FT  
OR 4" LINE = 87 LIN FT

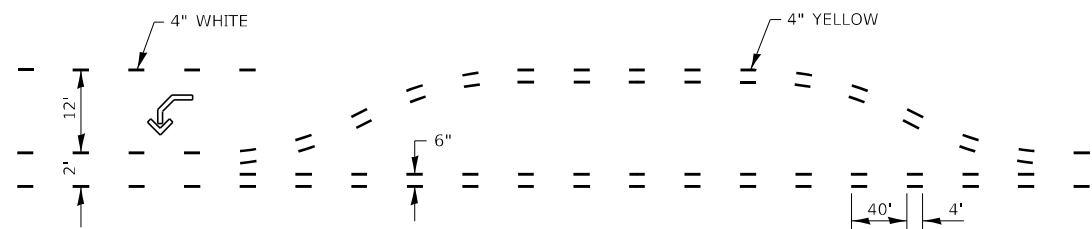

**SHORT-TERM PAVEMENT MARKING  
FOR MEDIANS AND ARROWS**

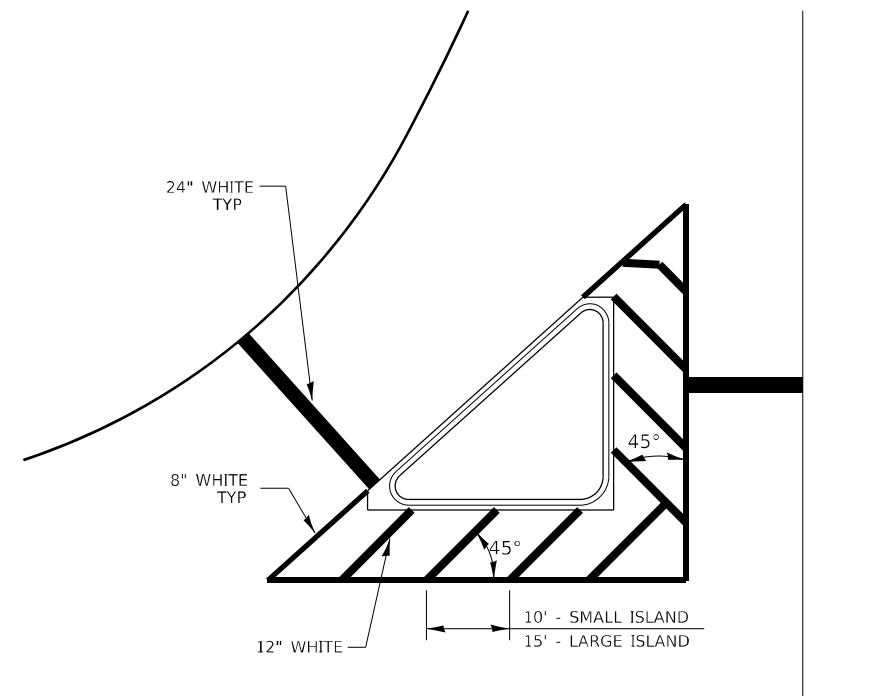

**TYPICAL ISLAND**

MODEL: Default  
FILE NAME: p:\i\idist-pw-bentley.com\P\IDOT\Documents\DOT Office\District 3\Project\3D366468\CADD\3D366468-plt-details.dgn

USER NAME = Anthony.Grunstad	DESIGNED -	REVISED -
PLOT SCALE = 100,0000' / in.	DRAWN -	REVISED -
PLOT DATE = 6/13/2022	CHECKED -	REVISED -
	DATE -	REVISED -

**STATE OF ILLINOIS  
DEPARTMENT OF TRANSPORTATION**

**PAVEMENT MARKING DETAILS**

SCALE: SHEET OF SHEETS STA. TO STA.

\* F.A.S. 2370 / OR 26

F.A.S. RTE. 2370*	SECTION (78-1)RS-2	COUNTY PUTNAM	TOTAL SHEETS 15	SHEET NO. 13
CONTRACT NO. 66M68			ILLINOIS FED. AID PROJECT	

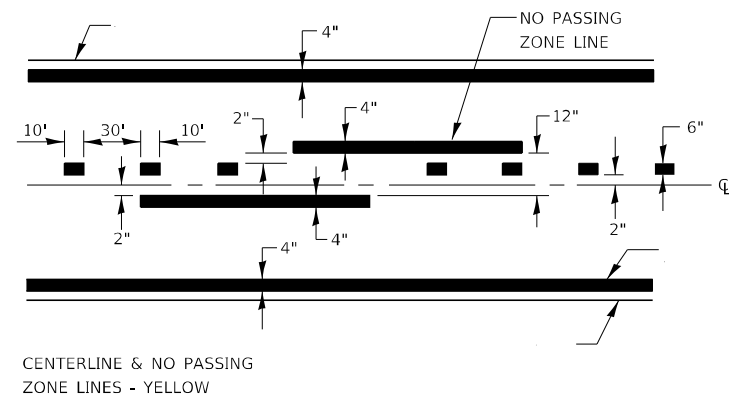

**PAVEMENT MARKING**

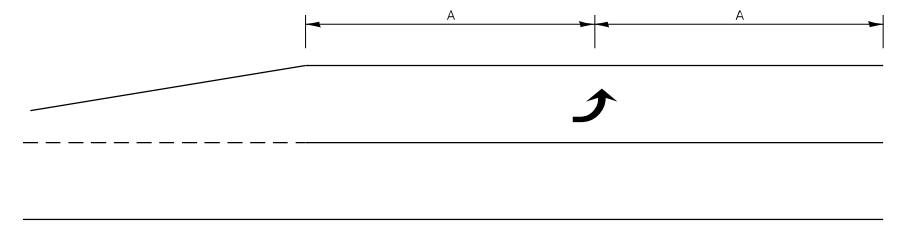

**99' AND UNDER**

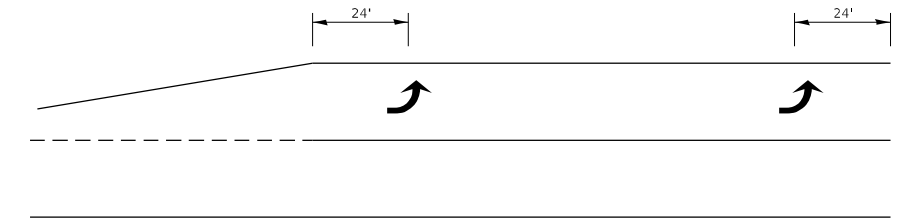

**100' TO 149'**

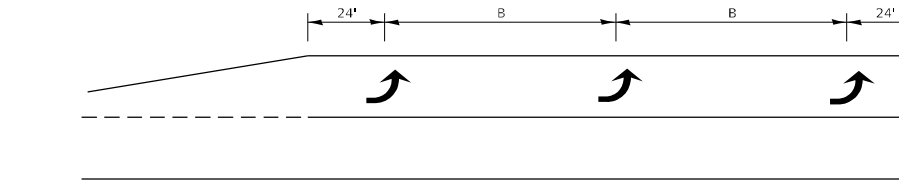

**150' AND LONGER**

**TYPICAL PLACEMENT OF ARROWS IN TURN LANES**

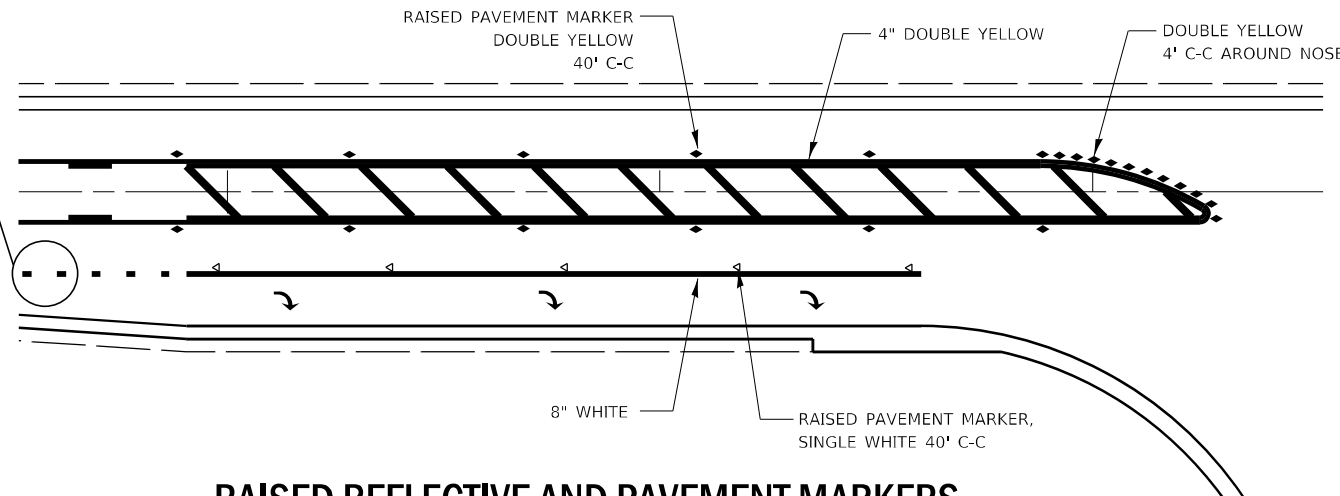
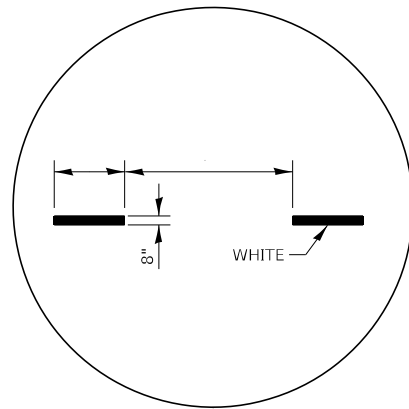

**RAISED REFLECTIVE AND PAVEMENT MARKERS @ RIGHT TURN LANE**

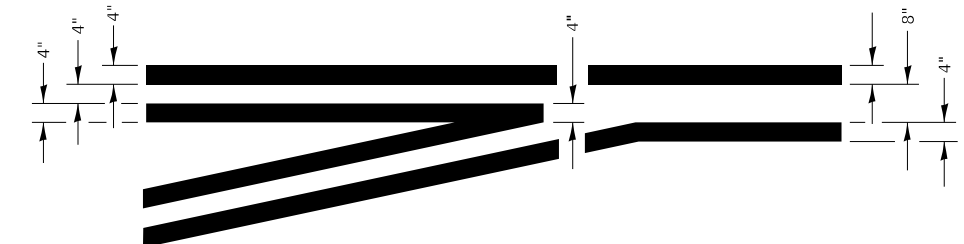

**TYPICAL APPLICATION @ LEFT TURN LANES**

MODEL: Default  
FILE NAME: p:\ultra\paw\_bentley.com\P\INDOT\Documents\DOT Office\Dir\dr: 3\Project\10366468\CADD\Draw: D366468-ah-Details.dgn

USER NAME = Anthony.Grunstad	DESIGNED -	REVISED -
PLOT SCALE = 100,0000' / in.	DRAWN -	REVISED -
PLOT DATE = 6/13/2022	CHECKED -	REVISED -
	DATE -	REVISED -

**STATE OF ILLINOIS  
DEPARTMENT OF TRANSPORTATION**

**PAVEMENT MARKING DETAILS**

SCALE: SHEET OF SHEETS STA. TO STA.

\* F.A.S. 2370 / OR 26

F.A.S. RTE. 2370*	SECTION (78-1)RS-2	COUNTY PUTNAM	TOTAL SHEETS 15	SHEET NO. 14
CONTRACT NO. 66M68			ILLINOIS FED. AID PROJECT	

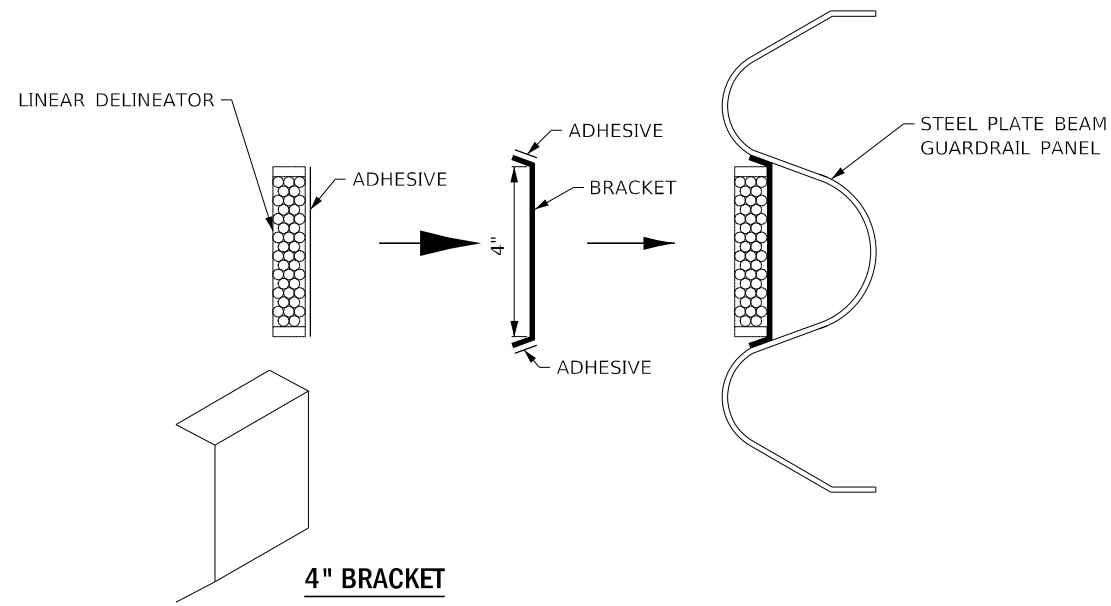

**LINEAR DELINEATOR APPLICATION TO STANDARD GALVANIZED GUARDRAIL**

LINEATOR DELINEATOR SHALL BE APLIED ACCORDING TO THE MANUFACTURER'S RECOMMENDATIONS

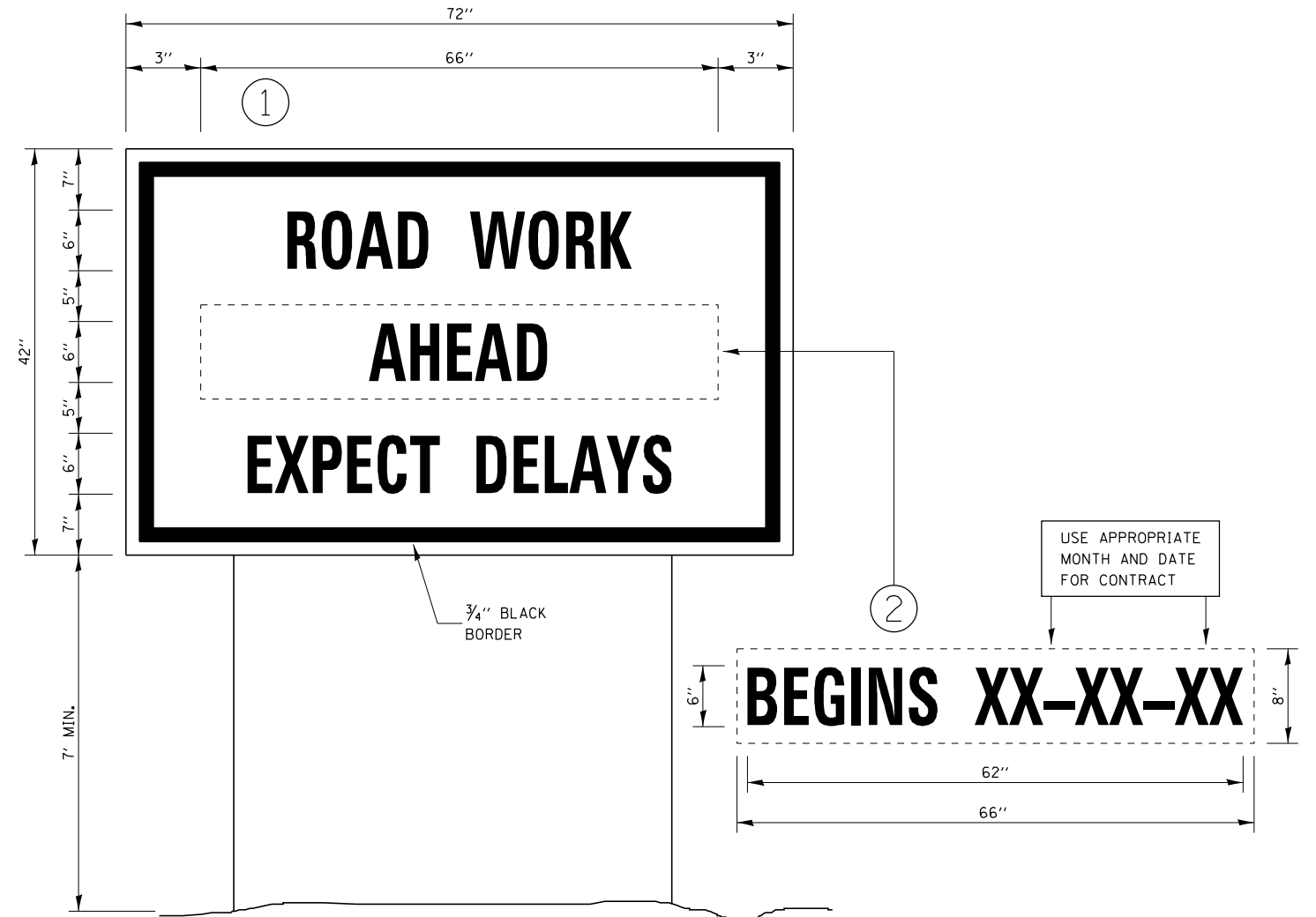

**TEMPORARY INFORMATION SIGNING**

**NOTES:**

1. USE 6" D BLACK LETTERING ON FLOURESENT ORANGE BACKGROUND.
2. ERECT SIGNS AT LOCATIONS IN ADVANCE OF THE "ROAD CONSTRUCTION AHEAD" SIGNS AS DIRECTED BY THE ENGINEER.
3. ERECT SIGN ① WITH INSTALLED PANEL ② A MINIMUM OF ONE WEEK PRIOR TO THE START OF THE LANE CLOSURE.
4. REMOVE PANEL ② ON THAT DATE.
5. SEE SPECIAL PROVISION "TEMPORARY INFORMATION SIGNING" FOR ADDITIONAL INFORMATION.
6. WILL BE PAID FOR PER SQ FT AS "TEMPORARY INFORMATION SIGNING". EACH SIGN = 21 SQ FT AND THE DATE PANEL ② WILL NOT BE MEASURED SEPARATELY FOR PAYMENT.

**NOTE:**

TEMPORARY INFORMATRION SIGNING INCLUDED FOR IL 26 NORTH, EASTBOUND I-180, AND WESTBOUND IL 71

MODEL: Default  
FILE NAME: p:\ultra-cw-beadray.com\PIV\DOT\Documents\DOT Office\Dir\dir: 3\Project\10366468\CADD\Date: 10366468-ah-Details.dgn

USER NAME = Anthony.Grunstad	DESIGNED -	REVISED -
	DRAWN -	REVISED -
PLOT SCALE = 100,0000 ' / in.	CHECKED -	REVISED -
PLOT DATE = 6/13/2022	DATE -	REVISED -

**STATE OF ILLINOIS  
DEPARTMENT OF TRANSPORTATION**

**DETAILS**

SCALE: SHEET OF SHEETS STA. TO STA.

\* F.A.S. 2370 / OR 26

F.A.S. RTE.	SECTION	COUNTY	TOTAL SHEETS	SHEET NO.
2370*	(78-1)RS-2	PUTNAM	15	15
CONTRACT NO. 66M68			ILLINOIS FED. AID PROJECT	