

④ Collar I.D. shall be manufactured to correspond to O.D. of actual galvanized post and stainless steel sleeve plus 1/8" (+1/16"). Maximum gap between post and collar at any location equals 1/8" before tightening bolts.

SECTION B-B
Bolts, washers (including contoured washers), and locknuts shall be stainless steel.

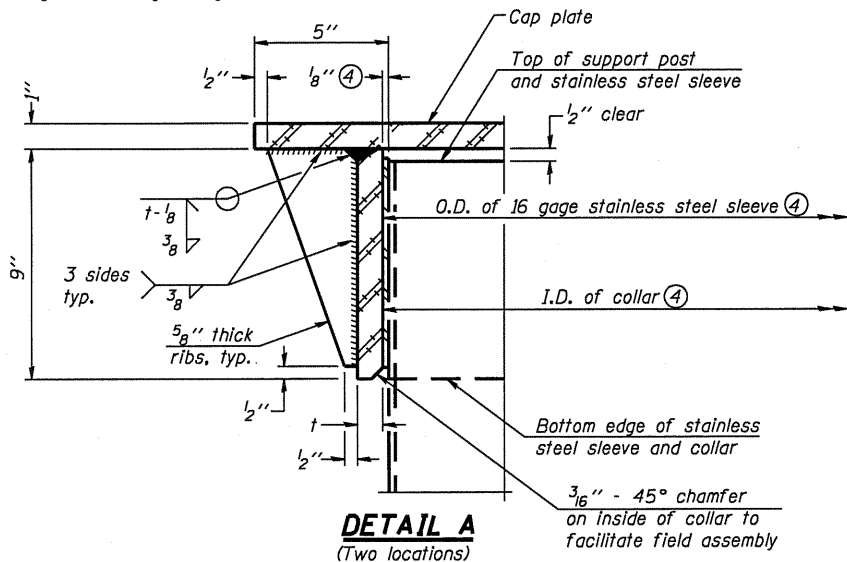

DETAIL A
(Two locations)

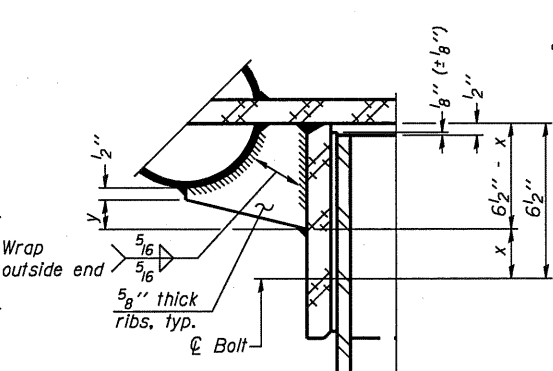

DETAIL B
Two locations
(For details not shown, see Detail C)

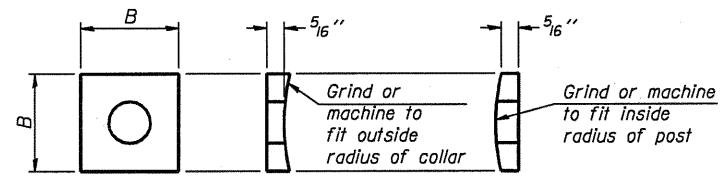

CONTOURED WASHERS

Bolt Size	Contoured Washers	
	Hole Dia.	B
7/8"	1"	2 1/2"
1"	1 1/8"	3"
1 1/4"	1 3/8"	3 1/4"

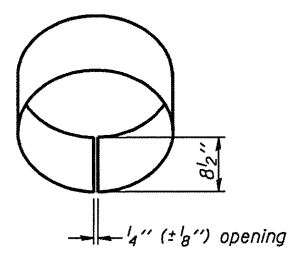

DETAIL OF STAINLESS STEEL SLEEVE

Weld to post after galvanizing.
(Prepare post surface to insure tight, uniform fit and allow welding.)
Welds to be 1/2" long at 6" cts. along top edge and at 1/4" opening.

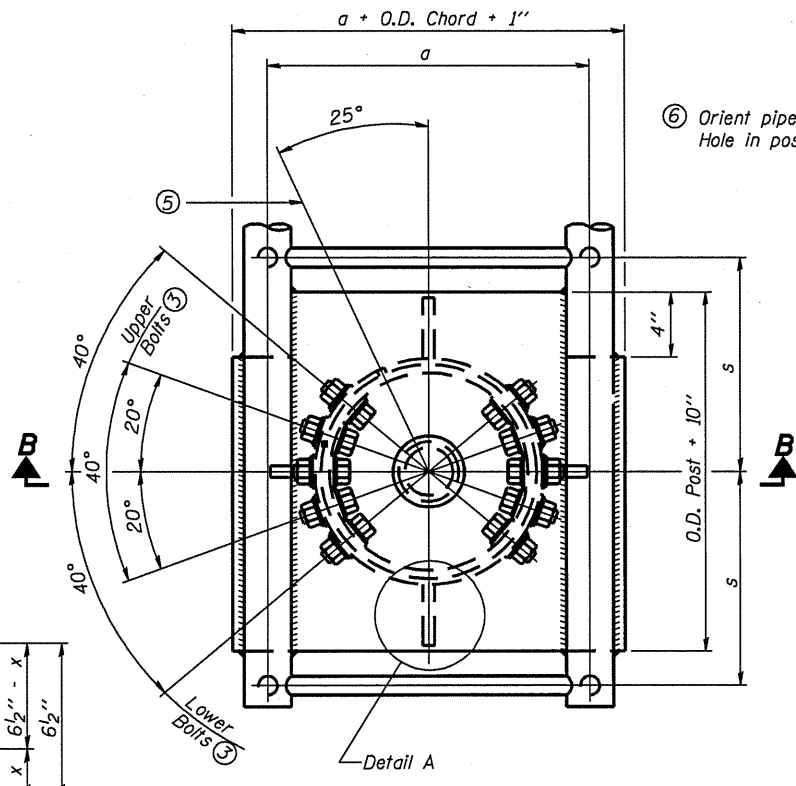

PLAN VIEW - TOP OF COLUMN

⑤ Optional full penetration weld in collar.
(Two locations maximum....(180° apart)....X-ray or UT 100%)

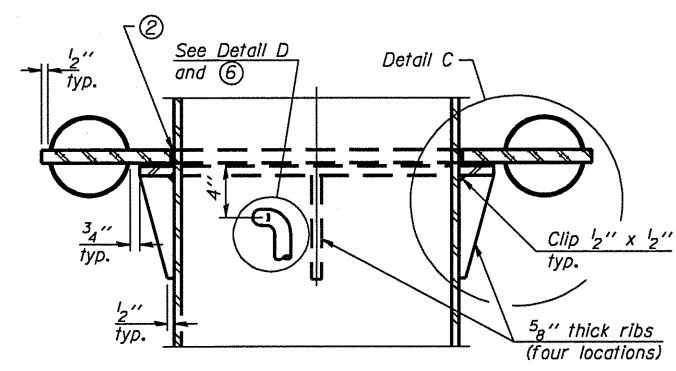

SECTION C-C

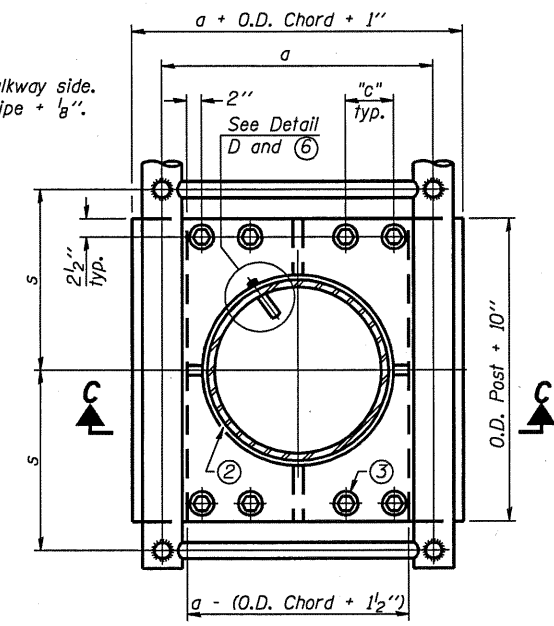

SECTION THRU POST ABOVE LOWER CHORDS

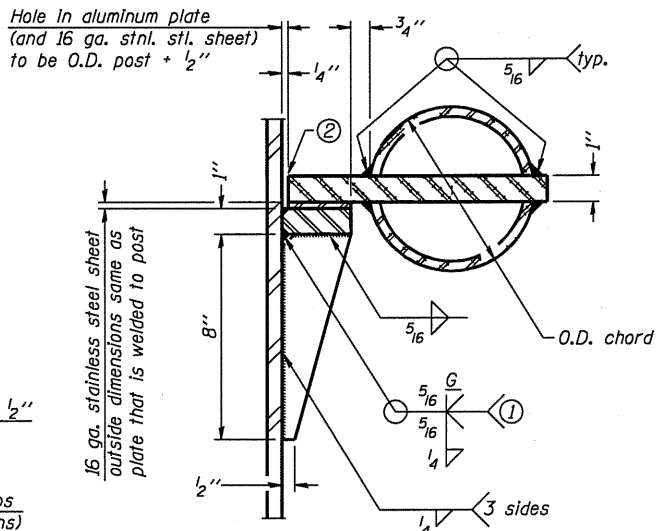

DETAIL C

Truss Type	Post Size	Upper & Lower Connection Bolt Diameter ③	Lower Juncture Bolt Spacing Dimension "c" ③	Opening in Cap Plate "HH"	Collar Thickness (t)	Side Ribs	
						x	y
I-C-A	16" φ (83#1/')	7/8"	3 1/4"	8"	5/8"	1 3/4"	2 1/4"
II-C-A	24" φ (125#1/')	1"	3 1/2"	12"	7/8"	2"	1 1/4"
III-C-A (35' max.)	24" φ (125#1/')	1 1/4"	3 1/2"	12"	7/8"	2"	1"
III-C-A (>35' to 40')	24" φ (171#1/')	1 1/4"	3 1/2"	12"	7/8"	2"	1"

- ① Grind top if required to fully seat aluminum plate and stainless steel sheet.
- ② After tightening lower connection bolts, fill gap with non-hardening, silicone caulk suitable for exterior exposure and acceptable to the Engineer. Cost is included in Overhead Sign Structure Cantilever.
- ③ Upper and lower connection bolts in collar and bolts at lower chord connection shall be high strength with matching locknuts. Connection bolts shall have 2 stainless steel flat washers each.

OSC-A-3

7-1-10

FILE NAME *	USER NAME * woodshankr1	DESIGNED - RON WOODSHANK	REVISED -
ct:\pw\work\psidot\woodshankr1\d02235124\6131-Details.dgn		DRAWN - RON WOODSHANK	REVISED -
PLOT SCALE = 100.0000 / IN.		CHECKED -	REVISED -
PLOT DATE = Sep 23, 2010 - 09:37:45 AM		DATE -	REVISED -

STATE OF ILLINOIS
DEPARTMENT OF TRANSPORTATION

CANTILEVER SIGN STRUCTURES - JUNCTURE DETAILS
ALUMINUM TRUSS & STEEL POST

F.A.I. RTE.	SECTION	COUNTY	TOTAL SHEETS	SHEET NO.
VAR	D-3 OVD SIN STR REPL 2011-08	VAR	25	18
SCALE: _____		SHEET NO. 3 OF 9 SHEETS		STA. _____ TO STA. _____
ILLINOIS				

CONTRACT NO. 46131