

FOR INFORMATION ONLY

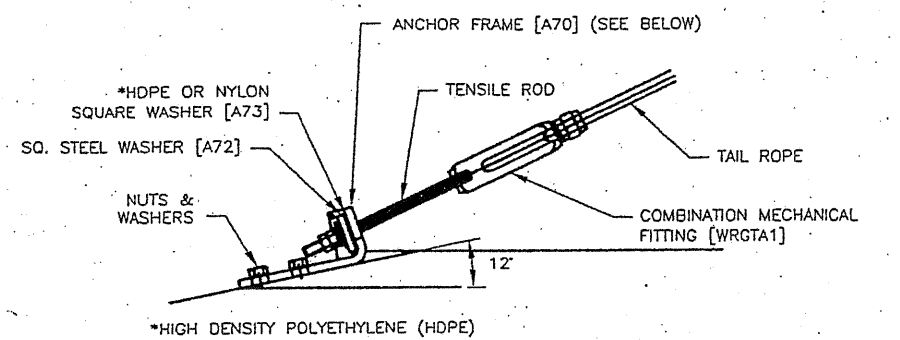

- NOTES:**
- BRIFEN DRAWINGS, SPECIFICATIONS & PRODUCT MANUAL SHOULD BE REVIEWED PRIOR TO STARTING AN INSTALLATION. FOR ASSISTANCE OR ADDITIONAL INFORMATION CALL 1-866-427-4336 TOLL FREE.
 - WIRE ROPE SAFETY FENCE (WRSF) IS RECOMMENDED FOR INSTALLATIONS ON SLOPES OF 6:1 OR FLATTER. THE AREA SHOULD BE RELATIVELY SMOOTH, WITHOUT EDGE DROP-OFFS, ABRUPT SLOPE CHANGES, HOLES, DEBRIS, ETC. THAT COULD PREVENT A VEHICLE FROM IMPACTING THE WRSF WITH ALL WHEELS ON THE GROUND AND SUSPENSION NORMAL. SOME FILLING AND/OR GRADING AND COMPACTION MAY BE NECESSARY. THE ROPES MUST BE PLACED AT DESIGN HEIGHT ABOVE GROUND LINE. TOLERANCE IS $\pm 1"$.
 - WRSF MAY BE INSTALLED ON EITHER SIDE OF THE ROADWAY. THE RADIUS EDGE OF POSTS SHALL BE ON THE APPROACH SIDE OF TRAFFIC. WEAKENING CUT (RELIEF NOTCH) AT GROUND LINE ON POST A & B TO BE PLACED TOWARD THE END ANCHOR. ALSO SEE SHEET 5.
 - ALL POSTS ARE SET IN SOCKETS UNLESS OTHERWISE SPECIFIED. ALL CONCRETE (BY OTHERS) TO BE 3500 PSI MINIMUM. EXPOSED SURFACES TO BE HAND TROWELED.
 - LINE POST SPACING AT 10'-6" SHOWN; MAY BE DECREASED IF NECESSARY. ADEQUATE CLEARANCE TO RIGID OBSTACLES SUCH AS BRIDGE PIERS, SIGN SUPPORTS, POWER POLES, TREES, ETC. IS CRITICAL. SEE PRODUCT MANUAL OR CONTACT MANUFACTURER.
 - WRGT END TERMINAL IS NCHRP 350 APPROVED AND MAY BE LOCATED WITHIN THE HORIZONTAL CLEAR ZONE. END TERMINAL FLARE RATE MAY NOT EXCEED 25:1; 50:1 OR LESS IS PREFERRED. USED FOR BOTH TL-3 & TL-4 SYSTEMS. NO MAXIMUM LIMIT TO LENGTH BETWEEN END TERMINALS.
 - WRGT END TERMINAL IS SUPPLIED AS A PACKAGE UNLESS SPECIFIED OTHERWISE. INCLUDES ANCHOR FRAME, REINFORCING CAGE, CONNECTION HARDWARE, COMBINATION MECHANICAL FITTING, POSTS TYPE A AND B, WRGT SOCKETS, PEGS, EXCLUDERS AND TAIL ROPES.
 - THE 15 TRANSITION LINE POSTS ADJACENT TO WRGT END TERMINAL DO NOT HAVE TOP ROPE SLOT. ALL THE ROPES WEAVE ON EITHER SIDE OF THE POSTS UNTIL THE FIRST LINE POST WITH A SLOT (POST 20). SEE SHEET 5.
 - END ANCHORAGE AND POST FOUNDATION SIZES ARE DETERMINED BY SOIL CLASSIFICATION AND CONDITION AS WELL AS TEMPERATURE EXTREMES. REFER TO PRODUCT MANUAL OR CONTACT BRIFEN USA REPRESENTATIVE FOR TECHNICAL ASSISTANCE.

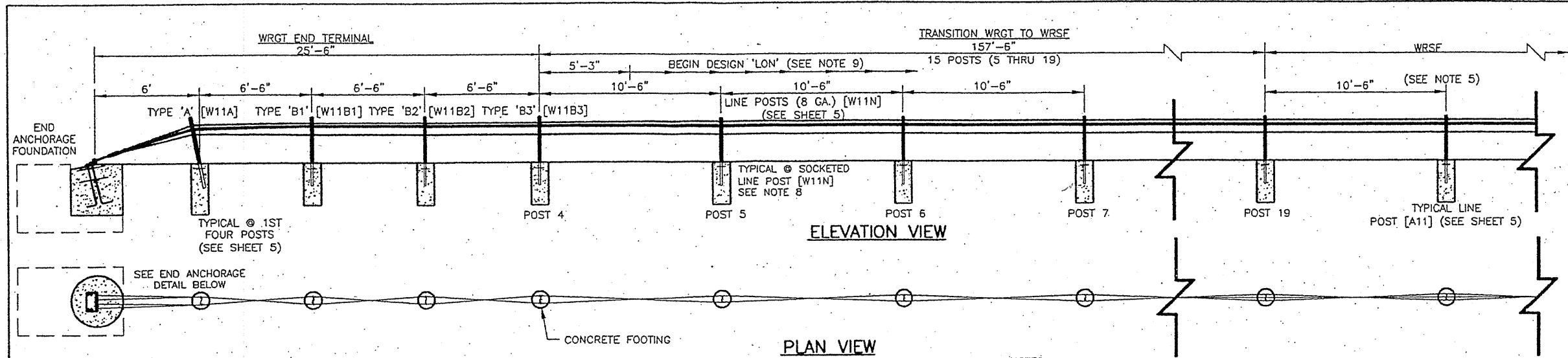
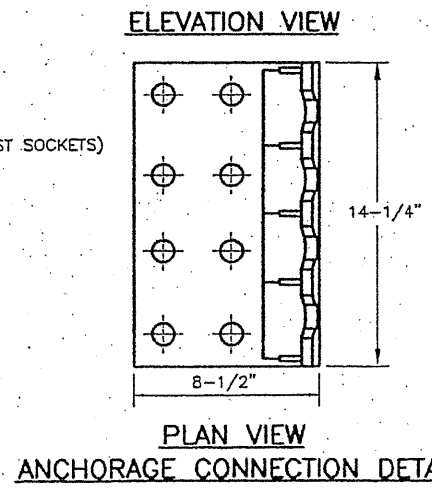
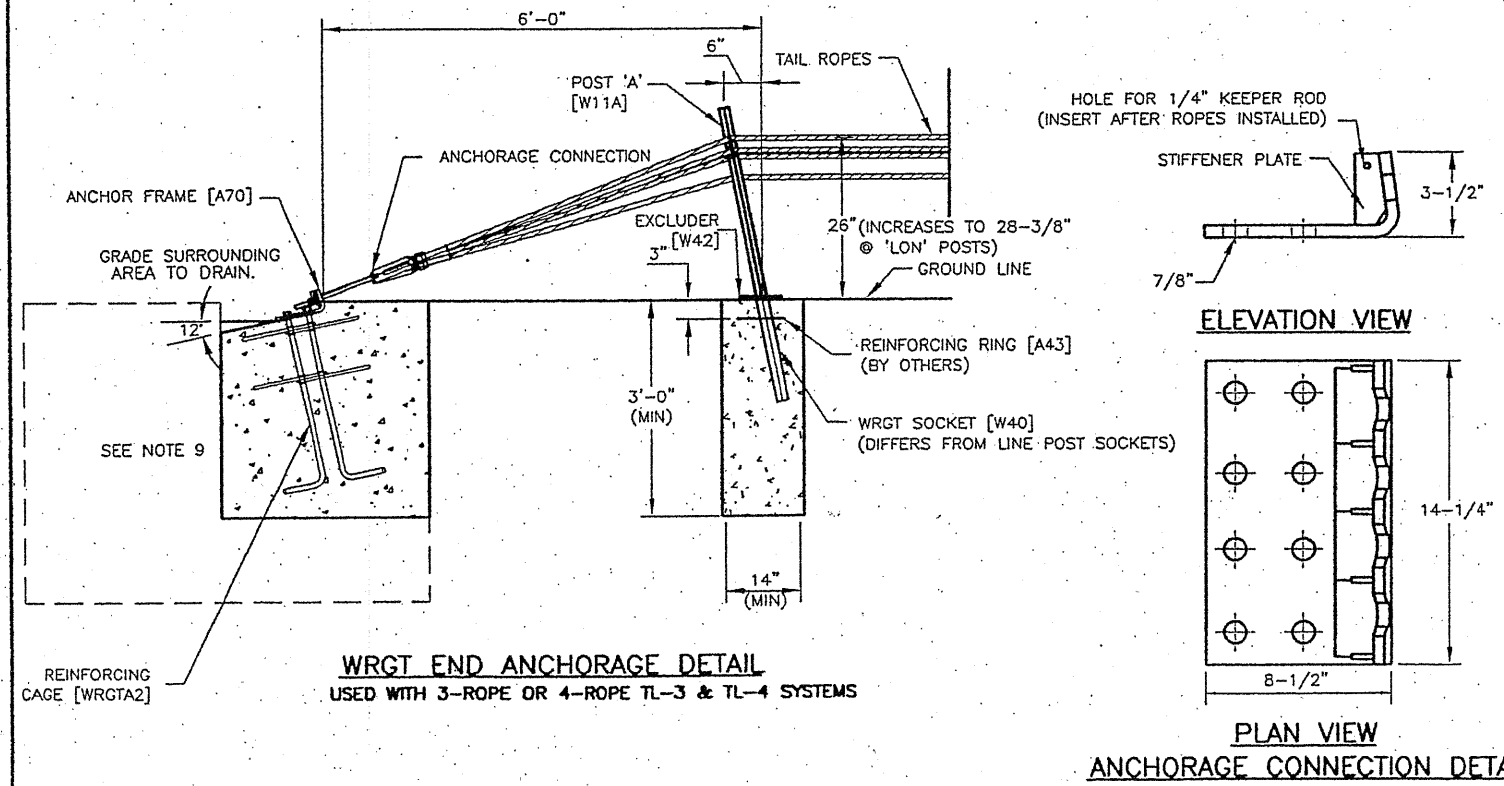

The information herein is proprietary to BRIFEN USA, and shall not be disclosed, duplicated or used otherwise without the express written consent of BRIFEN USA, Inc.

BRIFEN★USA INC.			
Revisions			GENERAL LAYOUT
No.	Date	By	USING WRGT END TERMINAL (NCHRP-350) AND TRANSITION
1.	7.21.05	MW	Date: 5.17.05, Drawn By: Manita Workman, Scale: None
2.	8.01.05	MW	VERSION 8.8
3.	8.04.05	MW	
4.	10.10.05	MW	Sheet No. 1 of 11
5.	12.16.05	MW	Dwg. No. WRSF-05-201a