

$7/16''$ ϕ holes at 4'-0" cts. for $3/8''$ ϕ bolts. All bolts shall be burned, sawed, or chipped off flush with the plates after forms are removed, typ.

Place $1/2''$ ϕ x 6" granular or solid flux filled headed studs conforming to Article 1006.32 of the Std. Specs., automatically end welded at 1'-0" alt. cts.

SECTION THRU STRIP SEAL JOINT

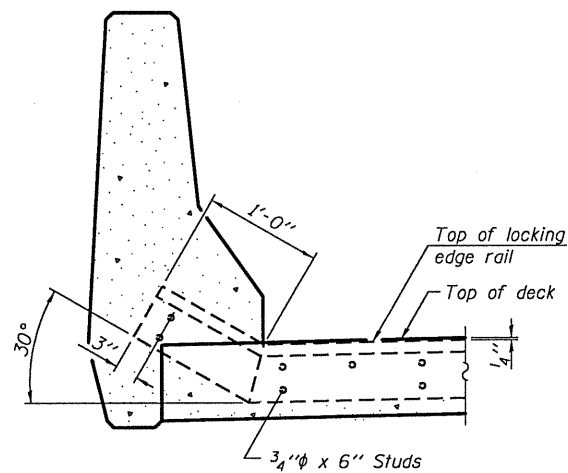

SECTION A-A

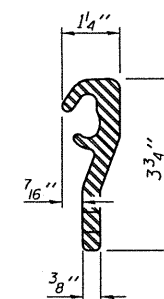

LOCKING EDGE RAIL

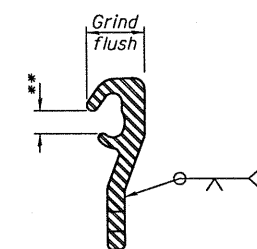

LOCKING EDGE RAIL SPLICE

Notes:

The strip seal shall be made continuous and shall have a minimum thickness of $1/4''$. The configuration of the strip seal shall match the configuration of the Locking Edge Rails. Open or "webbed" strip seal gland configurations are not permitted. The gland shall be sized for a maximum rated movement of 5 inches.

The Locking Edge Rails depicted are conceptual only, except for the minimum dimensions shown. The actual configuration of the Locking Edge Rails and matching strip seal may vary from manufacturer to manufacturer. Flanged edge rails will not be allowed. Locking Edge Rails may be spliced at slope discontinuities.

The manufacturer's recommended installation methods shall be followed.

The joint opening and deck dimensions detailed on the superstructure are based on a rolled rail expansion joint. If the Contractor elects to use the welded rail expansion joint, the opening and deck dimensions shall be modified according to the dimensions detailed on this sheet. Required modifications shall be made at no additional cost to the State.

All steel components shall be galvanized after fabrication according to Article 520.03 of the Standard Specifications.

Maximum space between rail segments at stage lines shall be $3/16''$, sealed with a suitable sealant.

Parapet plates and anchorage studs for skews $> 30^\circ$ included in the cost of Preformed Joint Strip Seal.

The inside of the Locking Edge Rail groove shall be free of weld residue.

The maximum temperature at which the strip seal gland (at the West Abutment) may be installed is 74° F.

When calculating the required joint opening (see Article 520.04 of the Standard Specifications) for the joint at the West Abutment, the expansion length is 413 feet for the joint calculations.

BILL OF MATERIAL

Item	Unit	Total
Preformed Joint Strip Seal	Foot	42

DESIGNED - MKC	EXAMINED <i>Ralph E. Anderson</i>	DATE - SEPTEMBER 27, 2010
CHECKED - GGE	ENGINEER OF STRUCTURAL SERVICES	
DRAWN - Kyle M. Steffen	PASSED <i>Ralph E. Anderson</i>	
CHECKED - MKC GGE	ENGINEER OF BRIDGES AND STRUCTURES	

STATE OF ILLINOIS
DEPARTMENT OF TRANSPORTATION

PREFORMED JOINT STRIP SEAL DETAILS AT WEST ABUTMENT
SN 075-0122 (E.B.)

SHEET NO. 7 OF 9 SHEETS

F.A.I. RTE.	SECTION	COUNTY	TOTAL SHEETS	SHEET NO.
72	(75, 86)BJR	PIKE	13	11
CONTRACT NO. 72D81			ILLINOIS FED. AID PROJECT	