

STATE OF ILLINOIS
DEPARTMENT OF TRANSPORTATION

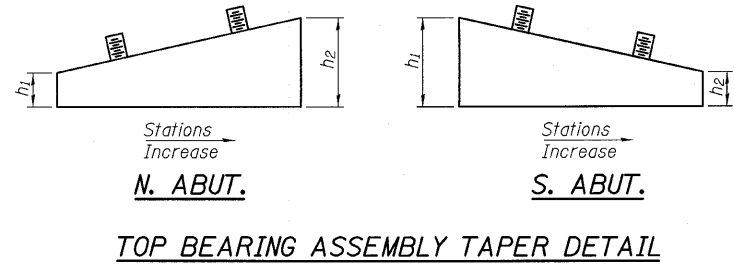

ELEVATION AT ABUT. SECTION A-A
TYPE III ELASTOMERIC EXP. BRG.

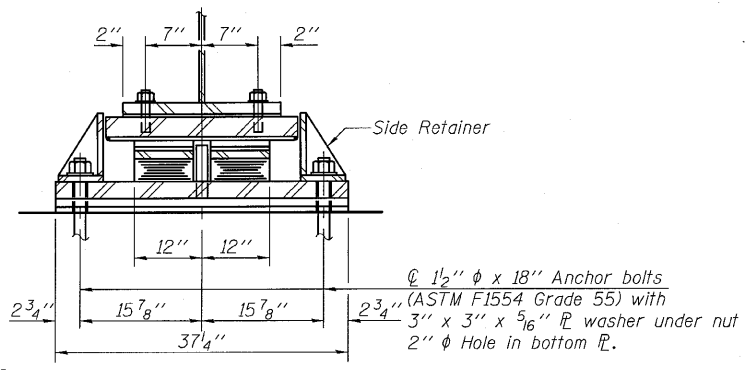
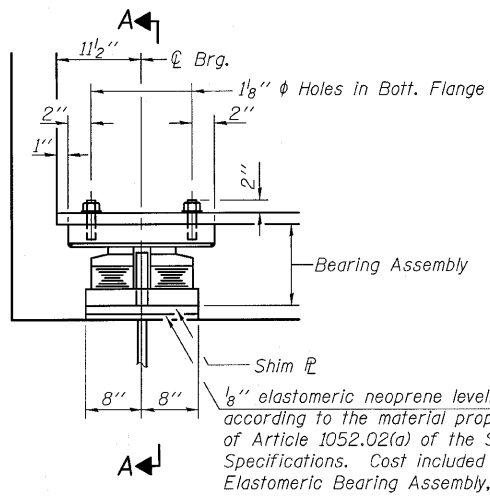
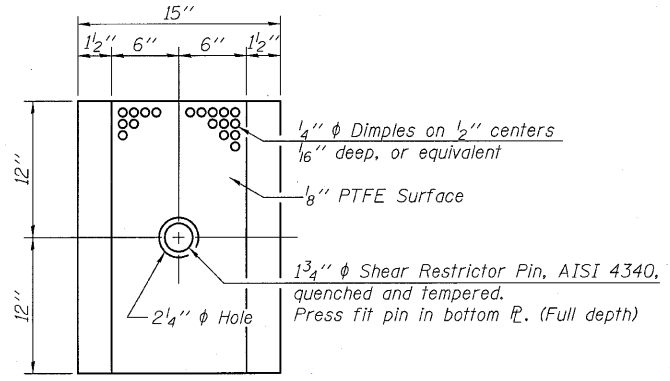
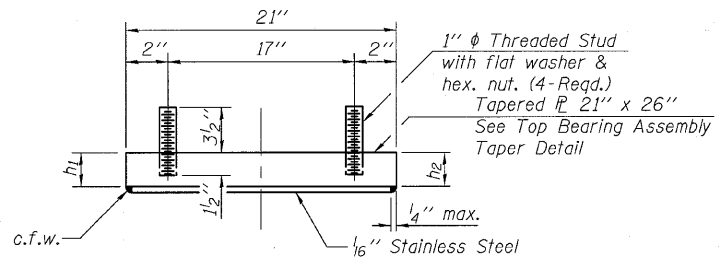

TOP BEARING ASSEMBLY

PLAN-PTFE ELASTOMERIC BRG.

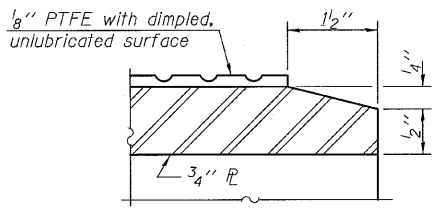
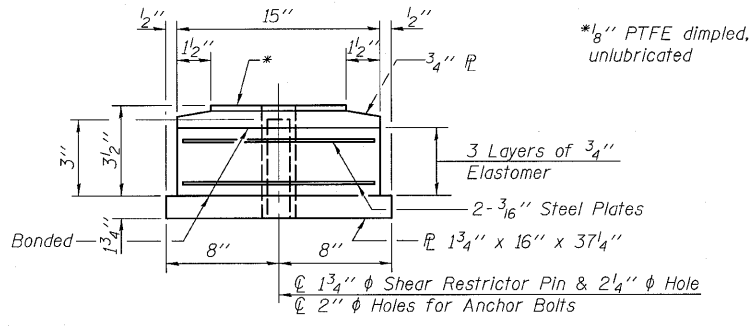

SECTION THRU PTFE

BOTTOM BEARING ASSEMBLY

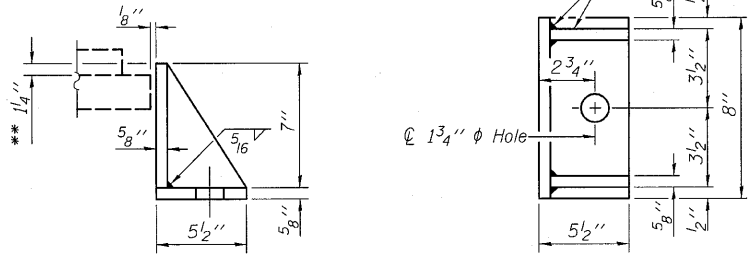

SIDE RETAINER
Equivalent rolled angle with stiffeners will be allowed in lieu of welded plates.

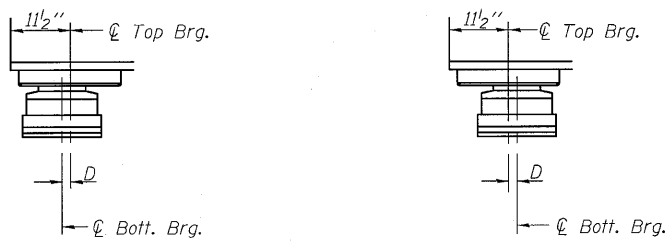

BELOW 50° F. (Move bottom brg. away from Sta. 281+45.84)
ABOVE 50° F. (Move bottom brg. toward Sta. 281+45.84)

SETTING ANCHOR BOLTS AT EXP. BRG.
D=1/8" per each 100' of expansion from Sta. 281+45.84 for every 15° temp. change from the normal temp. of 50° F.

TABLE OF VARIABLE DIMENSIONS

Location	h ₁	h ₂
N. Abut.	2 3/8"	3 1/4"
S. Abut.	3 3/16"	2 7/16"

Notes:
Anchor bolts shall be ASTM F1554 all-thread (or an Engineer-approved alternate material) of the grade(s) and diameter(s) specified. ASTM A307 Grade C anchor bolts may be used in lieu of ASTM F1554 Grade 36 (F_y=36ksi). The corresponding specified grade of AASHTO M314 anchor bolts may be used in lieu of ASTM F1554.
Anchor bolts for Type III bearings shall be placed in holes drilled in the concrete through holes in the bottom bearing plate after members are in place. Side retainers shall be placed after bolts are installed.
Drilled and set anchor bolts shall be installed according to Article 521.06 of the Standard Specifications.
Side retainers and other steel members required for the bearing assembly shall be included in the cost of Elastomeric Bearing Assembly, Type III.
The 1/8" PTFE sheet shall be bonded directly to the top steel plate with a two-component, medium viscosity epoxy resin, conforming to the requirements of the Federal Specification MMM-A-134, Type I. The bond agent shall be applied on the full area of the contact surfaces.
Bonding of 1/8" PTFE sheet during vulcanizing process will be permitted provided the process and method of adjusting assembly height is approved by the Engineer.
The structural steel plates of the Bearing Assembly shall conform to the requirements of AASHTO M 270 Grade 50.
Two 1/8 in. adjusting shims shall be provided for each bearing in addition to all other plates or shims and placed as shown on bearing details.

BILL OF MATERIAL

Item	Unit	Total
Elastomeric Bearing Assembly, Type III	Each	14
Anchor Bolts, 1 1/2"	Each	28

BEARING DETAILS
STRUCTURE NO. 082-0038

** Measured at ϕ Brg.

DESIGNED	JJD
CHECKED	EML
DRAWN	AJF
CHECKED	EML

HORNER & SHIFRIN, INC.
ENGINEERS

SHEET NO. 34 48 SHEETS	F.A.P. RTE. 312	SECTION 64-1VBR	COUNTY ST. CLAIR	TOTAL SHEETS 259	SHEET NO. 86
	CONTRACT NO. 76882				ILLINOIS FED. AID PROJECT