

INDEX OF SHEETS

SHEET NO.	DESCRIPTION
1	TITLE SHEET & SUMMARY OF QUANTITIES
2	PLAN & PROFILE, TYPICAL SECTIONS, GENERAL NOTES & STONE RIPRAP DITCH DESIGN
3-4	ROADWAY CROSS SECTIONS
5-12	BRIDGE DESIGN

THE FOLLOWING STANDARDS ARE A PART OF THESE PLANS AND ARE INCLUDED IN THE PROPOSAL:

000001-05	STANDARD SYMBOLS, ABBREVIATIONS & PATTERNS
280001-05	TEMPORARY EROSION CONTROL SYSTEMS
515001-03	NAME PLATE FOR BRIDGES
701901-01	TRAFFIC CONTROL DEVICES
B.L.R. 21-8	TYPICAL APPLICATION OF TRAFFIC CONTROL DEVICES FOR CONSTRUCTION ON RURAL LOCAL HIGHWAYS
B.L.R. 22-6	TYPICAL APPLICATION OF TRAFFIC CONTROL DEVICES FOR CONSTRUCTION ON RURAL LOCAL HIGHWAYS (TWO-LANE TWO-WAY RURAL TRAFFIC) (ROAD CLOSED TO THRU TRAFFIC)

SUMMARY OF QUANTITIES

CODE NO.	ITEM	UNIT	QUANTITY
20100210	TREE REMOVAL (OVER 15 UNITS DIAMETER)	UNIT	22.00
20200100	EARTH EXCAVATION	CU YD	811.00
20300100	CHANNEL EXCAVATION	CU YD	158.00
20400800	FURNISHED EXCAVATION	CU YD	1280.00
* X2501000	SEEDING, CLASS 2 (SPECIAL)	ACRE	0.70
28000305	TEMPORARY DITCH CHECKS	FOOT	48.00
28001000	AGGREGATE (EROSION CONTROL)	TON	9.00
28100807	STONE DUMPED RIPRAP, CLASS A4	TON	375.00
20008900	STONE LINED DITCH	TON	75.00
40200800	AGGREGATE SURFACE COURSE, TYPE B	TON	460.00
50100100	REMOVAL OF EXISTING STRUCTURES	EACH	1.00
50300225	CONCRETE STRUCTURES	CU YD	22.20
50300280	CONCRETE ENCASEMENT	CU YD	2.80
50400405	PRECAST PRESTRESSED CONCRETE DECK BEAMS (21" DEPTH)	SQ FT	1200.00
50800105	REINFORCEMENT BARS	POUND	2420.00
Δ 50900205	STEEL RAILING, TYPE S1	FOOT	96.00
51201400	FURNISHING STEEL PILES 10X42	FOOT	380.00
51202305	DRIVING PILES	FOOT	380.00
51500100	NAME PLATES	EACH	1.00
54200220	PIPE CULVERTS, CLASS D, TYPE 1 15"	FOOT	30.00
54200223	PIPE CULVERTS, CLASS D, TYPE 1 18"	FOOT	40.00
60801015	FLAP GATE 15"	EACH	1.00
* 67100100	MOBILIZATION	L SUM	1.00

Δ SPECIALTY ITEMS

DESIGN DESIGNATION:
DESIGN SPEED: 40 MPH
HIGHWAY CLASS - COLLECTOR
EXISTING STRUCTURE NO.: 097-3019
PROPOSED STRUCTURE NO.: 097-3268
CURRENT A.D.T. = 80
CONTRACT NO. 99431

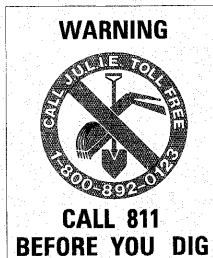

STATE OF ILLINOIS

DEPARTMENT OF TRANSPORTATION

DIVISION OF HIGHWAYS

PLANS FOR PROPOSED FEDERAL-AID SECONDARY PROJECT

F.A.S. 1884 WHITE COUNTY SECTION 09-00114-00-BR

PROJECT NO. RS-1884(113) JOB NO. C-99-548-09

CONTRACT # 99431 ELLIOTT CREEK TRIBUTARY

FAS	SECTION	COUNTY	TOTAL SHEETS	SHEET NO.
1884	09-00114-00-BR	WHITE	12	1

323 W. 3RD ST.
P.O. BOX 160
MT. CARMEL, IL
62863
PHONE:
(618)-262-8651
FAX:
(618)-263-3327

405 W. STATE ST.
SUITE 1
PRINCETON, IN
47670
PHONE:
(812)-386-7611
FAX:
(812)-385-2612

PROJECT# RS-1884(113) CONTRACT# 99431
JOB # C-99-548-09 ELLIOTT CREEK TRIB.
LEC JOB # H091008WH

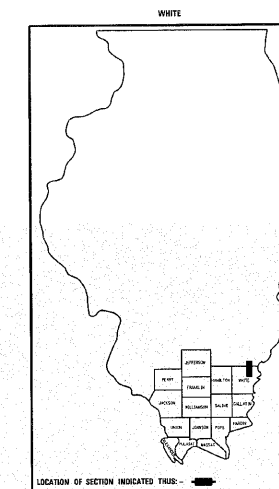

PROFESSIONAL DESIGN FIRM
LAND SURVEY &
PROFESSIONAL
ENGINEERING
CORPORATION
184-000887
(62-032435)(35-002769)

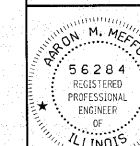

AARON M. MEFFORD
NAME
SIGNATURE
8-3-10
DATE
11-30-11
EXPIRES

FAS 1884
OVER ELLIOTT CREEK TRIBUTARY
WHITE COUNTY, ILLINOIS

SHEET TITLE:

TITLE SHEET

SCALE: VARIES

BY: AMM

DATE: 8/2/10

REV:

1 OF 12
SHEETS

SHEET NO.
1

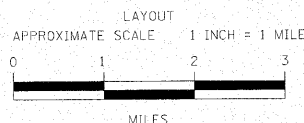
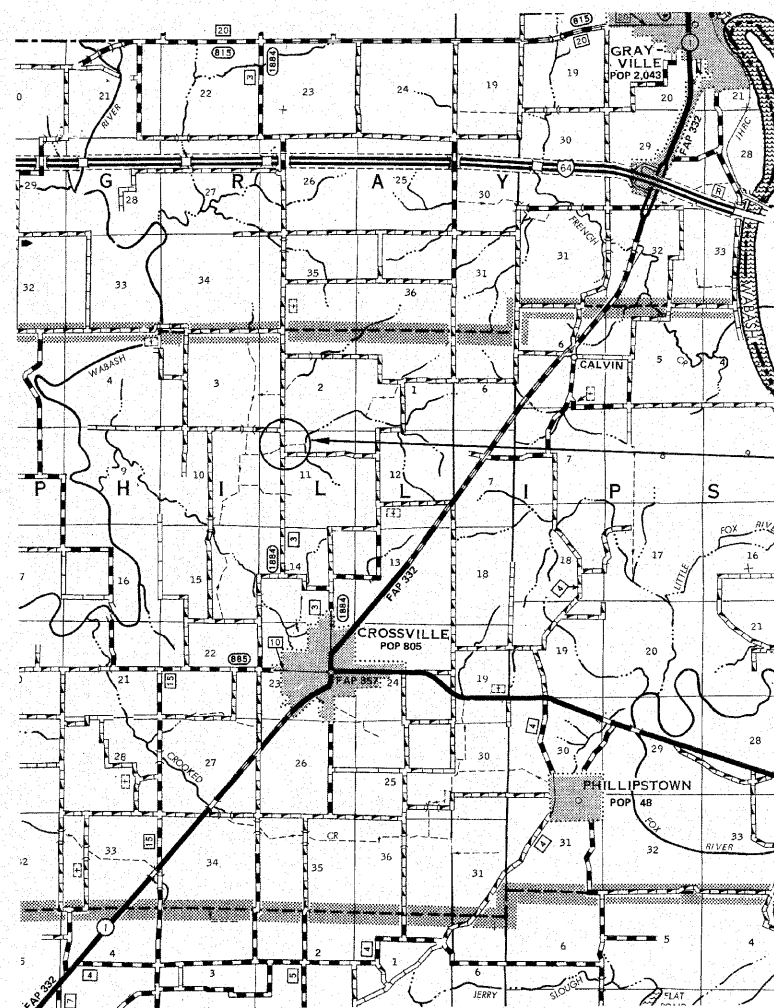

	FEET	MILES
GROSS LENGTH	685.00 FT	0.130 MILES
OMISSIONS	0.00 FT	0.000 MILES
NET LENGTH	685.00 FT	0.130 MILES

PLAN	1" = 50'	0 50' 100'
PROFILE	1" = 50'	0 50' 100'
PROFILE VERT.	1" = 5'	0 5' 10'
CROSS SECTION	1" = 5'	0 5' 10'

SECTION 09-00114-00-BR
BEGINS STATION 1+65

STATION 5+00, STRUCTURE NO. 097-3268
A 50' LONG SINGLE SPAN PRECAST PRESTRESSED
CONCRETE DECK BEAM BRIDGE (21" DEPTH),
24' ROADWAY, 0.00% GRADE, 0° SKEW.

SECTION 09-00114-00-BR
ENDS STATION 8+50

STATE OF ILLINOIS
DEPARTMENT OF TRANSPORTATION

APPROVED August 3, 2010

Brian A. Ray
COUNTY ENGINEER

PASSED August 12, 2010

Dennis W. Hillbren
ENGINEER OF LOCAL ROADS AND STREETS

RELEASING FOR BID
BASED ON LIMITED
REVIEW: August 12, 2010

Mary C. Lamie
MARY C. LAMIE, P.E.
DEPUTY DIRECTOR OF HIGHWAYS
REGION FIVE ENGINEER



PROFESSIONAL DESIGN FIRM
LAND SURVEY & PROFESSIONAL ENGINEERING CORPORATION
184-00087
(62-082435)(35-002769)

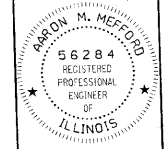

AARON M. MEFFORD
NAME
SIGNATURE
8-3-10
DATE
11-30-11
EXPIRES

FAS 1884
OVER ELLIOTT CREEK TRIBUTARY
WHITE COUNTY, ILLINOIS

SHEET TITLE:
PLAN & PROFILE

SCALE: VARIES
BY: AMM
DATE: 8/3/10
REV:

2 OF 12
SHEETS
SHEET NO.
2

GENERAL NOTES:

THIS SECTION SHALL BE CONSTRUCTED IN ACCORDANCE WITH THE PLANS, SPECIAL PROVISIONS AND "STANDARD SPECIFICATIONS FOR ROAD AND BRIDGE CONSTRUCTION", ADOPTED JANUARY 1, 2007.

THE WORK INVOLVED ON THIS SECTION CONSISTS OF THE REMOVAL OF THE EXISTING STRUCTURE, THE CONSTRUCTION OF A 50 FOOT LONG SINGLE SPAN PRECAST, PRESTRESSED CONCRETE DECK BEAM BRIDGE, EARTH APPROACHES, AGGREGATE SURFACE COURSE AND OTHER MISCELLANEOUS ITEMS NECESSARY TO COMPLETE THIS SECTION.

ALL ELEVATIONS ARE BASED ON U.S.G.S. MEAN SEA LEVEL DATUM.

IT SHALL BE THE CONTRACTOR'S RESPONSIBILITY TO CONTACT ALL THE UTILITIES, AFFECTING THE PROJECT, PRIOR TO CONSTRUCTION.

NOTE: CONSTRUCTION TRANSITIONS
STA 1+65 TO STA 2+00
STA 8+00 TO STA 8+50
ALL QUANTITIES ARE INCLUDED IN THE PROPOSAL

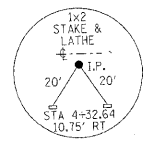
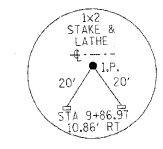
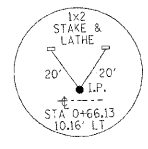

TYPICAL CROSS SECTION PROPOSED

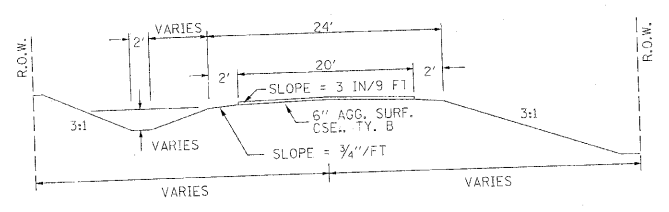

TYPICAL CROSS SECTION EXISTING

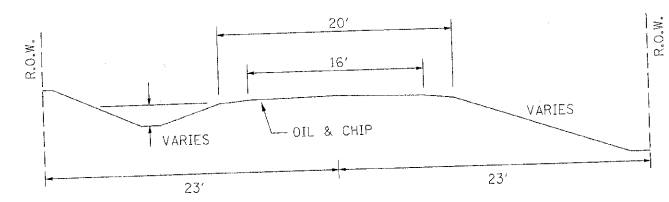

FIELD ENTRANCE DETAIL

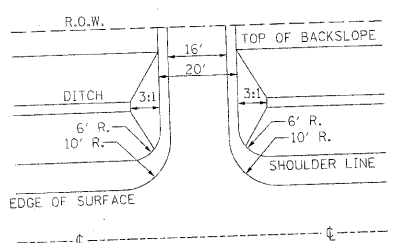

NOTE: CONSTRUCT SPECIAL DITCH
STA 1+65 TO STA 4+79 LT & RT
STA 5+19 TO STA 8+50 LT
STA 5+17 TO STA 8+50 RT

NOTE: CONSTRUCT STONE RIPRAP DITCH
STA 4+50 TO STA 4+79 LT & RT (0.62 TON/LIN FT)
STA 5+19 TO STA 5+50 LT (0.62 TON/LIN FT)
STA 5+17 TO STA 5+50 RT (0.62 TON/LIN FT)
75 TON STONE RIPRAP DITCH ALLOWED IN PROPOSAL.

SEE STONE RIPRAP DITCH DETAIL.

STONE RIPRAP DITCH DESIGN

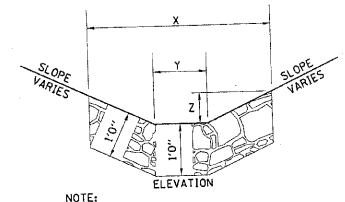
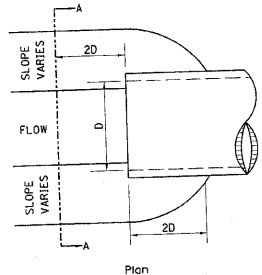

NOTE:

BOTTOM OF DITCH	SLOPE		
2 FT	X = 5 FT	6 FT	8 FT
	Y = 2 FT	2 FT	2 FT
	Z = 1 FT	1 FT	1 FT
	0.40	0.48	0.62 TON/LIN. FT

NOTE: FOR PLACEMENT, QUALITY GRADATION AND OTHER MISCELLANEOUS REQUIREMENTS FOR STONE RIPRAP DITCH-SEE SPECIAL PROVISIONS.

SECTION 09-00114-00-BR BEGINS STA 1+65

SECTION 09-00114-00-BR ENDS STA 8+50

UTILITIES:
J.U.L.I.E. 1-800-892-0123
CROSSVILLE WATER 1-618-966-2237
CROSSVILLE TELEPHONE 1-618-966-2196
AMEREN CIPS 1-888-789-2477

EXISTING BRIDGE STA 5+00.5; STRUCTURE NUMBER: 097-3019
A 18' LONG SINGLE SPAN BRIDGE WITH 18" CONCRETE DECK WITH 11" CURB ON WOOD PILING WITH WOOD MUDWALLS AND WOOD WINGWALLS. ALSO HAS BRIDGE RAILING.

ONE (1) EACH-REMOVAL OF EXISTING STRUCTURES ALLOWED IN THIS PROPOSAL.

NOTE: FILL NEXT TO BRIDGE TO BE AGGREGATE SURFACE COURSE

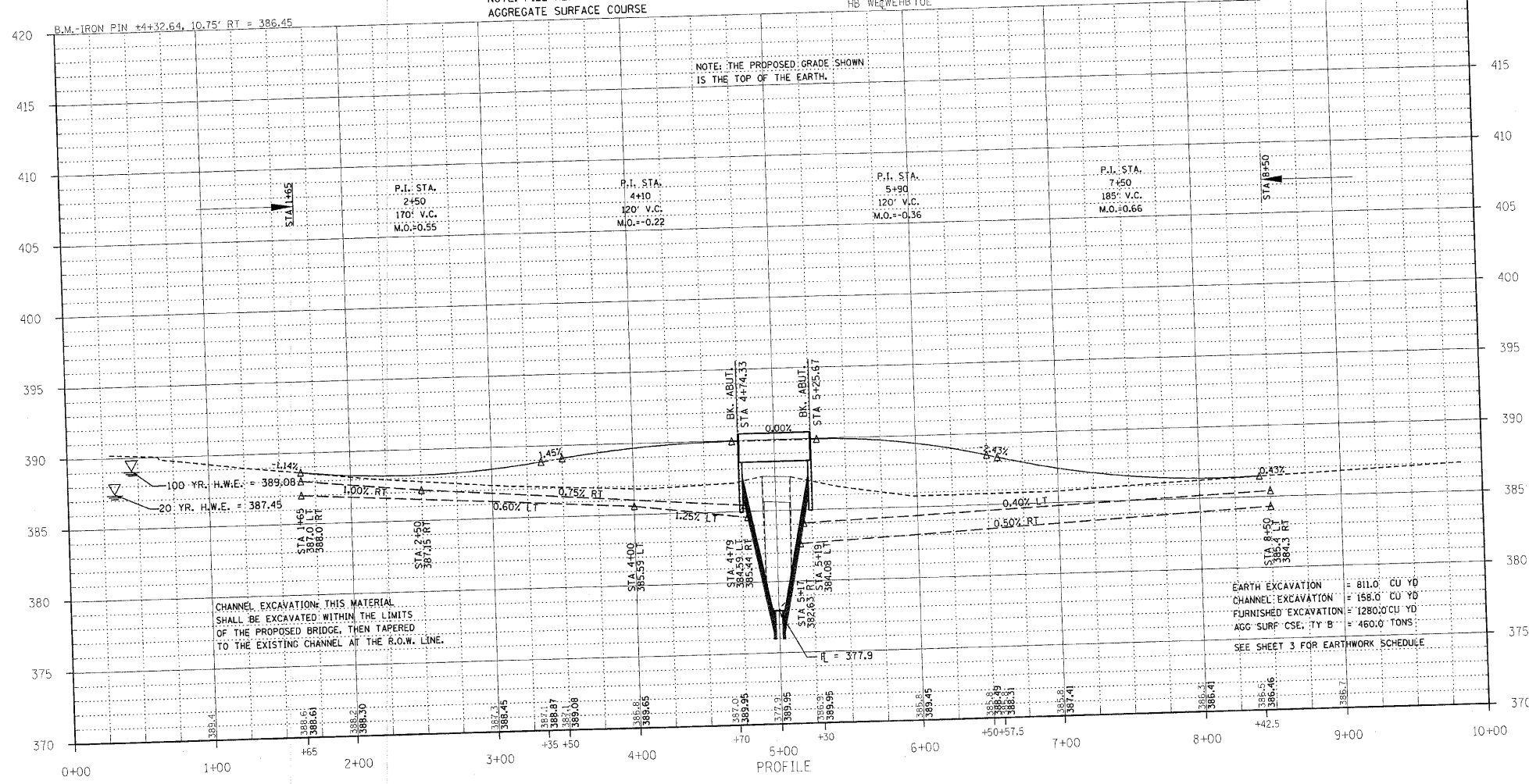

EARTH EXCAVATION = 811.0 CU YD
CHANNEL EXCAVATION = 158.0 CU YD
FURNISHED EXCAVATION = 1280.0 CU YD
AGG SURF CSE, TY B = 460.0 TONS
SEE SHEET 3 FOR EARTHWORK SCHEDULE

FAS	SECTION	COUNTY	TOTAL SHEETS	SHEET NO.
1884	09-00114-00-BR	WHITE	12	3
FED. ROAD DIST. NO. 9 ILLINOIS		FED. AID PROJECT		
PROJECT* RS-1884(113)		CONTRACT* 99431		
JOB NO. C-99-546-09		ELLIOTT CREEK TRIB.		
LEC JOB # 1091.0086H				

323 W. 3RD ST.
P.O. BOX 16
MT. CARMEL, IL
62863
PHONE:
(618)-262-8651
FAX:
(618)-263-3327

405 W. STATE ST.
SUITE 1
PRINCETON, IN
47670
PHONE:
(812)-386-7611
FAX:
(812)-385-2812

PROFESSIONAL
DESIGN FIRM
LAND SURVEY &
PROFESSIONAL
ENGINEERING
CORPORATION
184-00087
(62-024235)(35-002769)

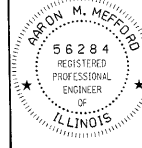

AARON M. MEFFORD
NAME
Aaron M. Mefford
SIGNATURE
8-3-10
DATE
11-30-11
EXPIRES

FAS 1884
OVER ELLIOTT CREEK TRIBUTARY
WHITE COUNTY, ILLINOIS

SHEET TITLE:
CROSS-SECTIONS
SCALE: 1" = 5'
BY: AMM
DATE: 8/2/10
REV:
3 OF 12 SHEETS
SHEET NO. 3

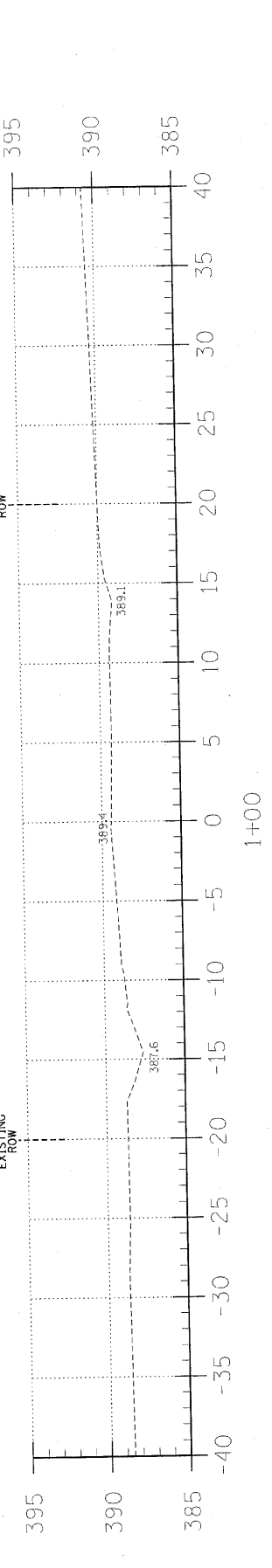
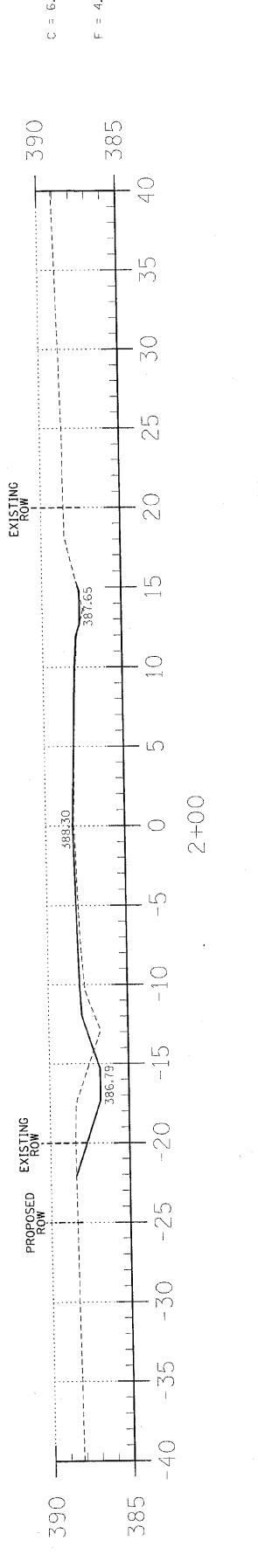
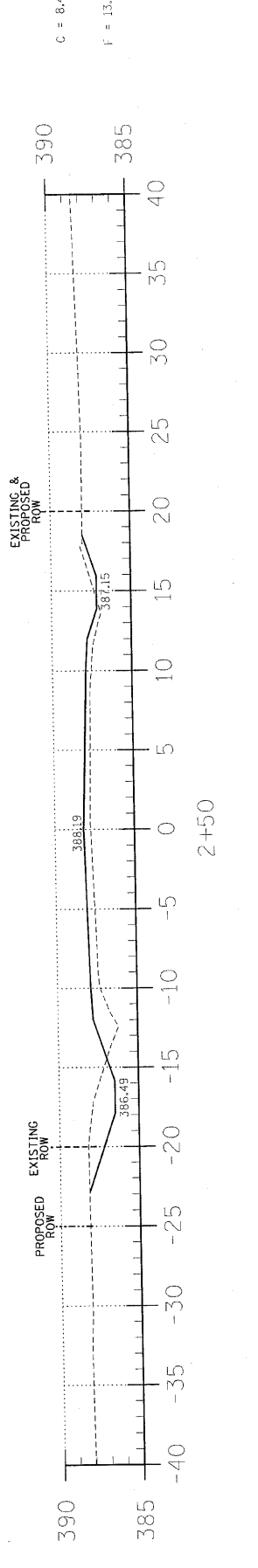
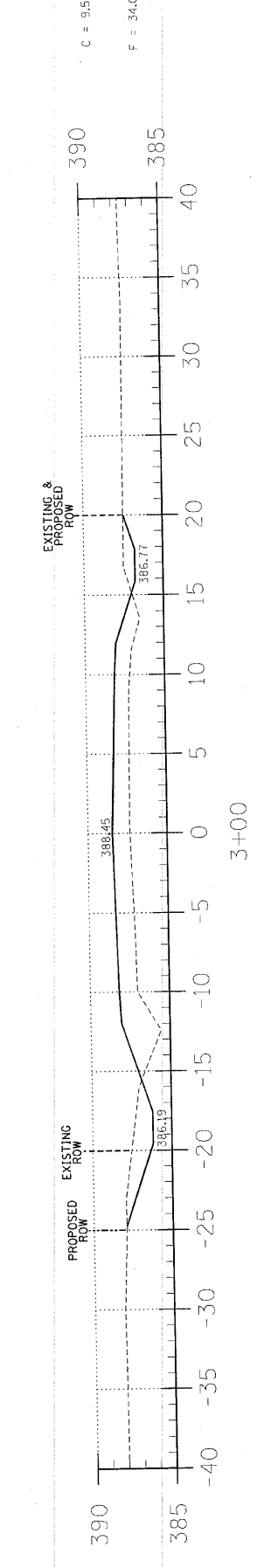
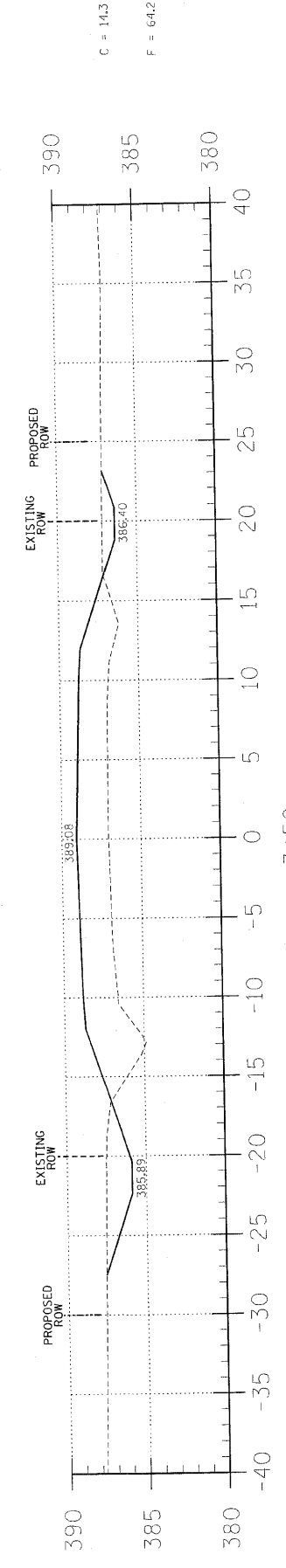
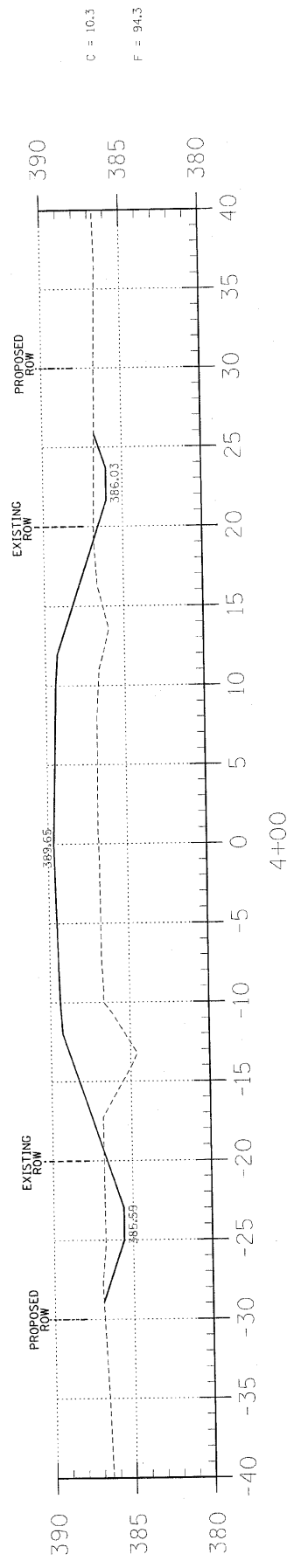
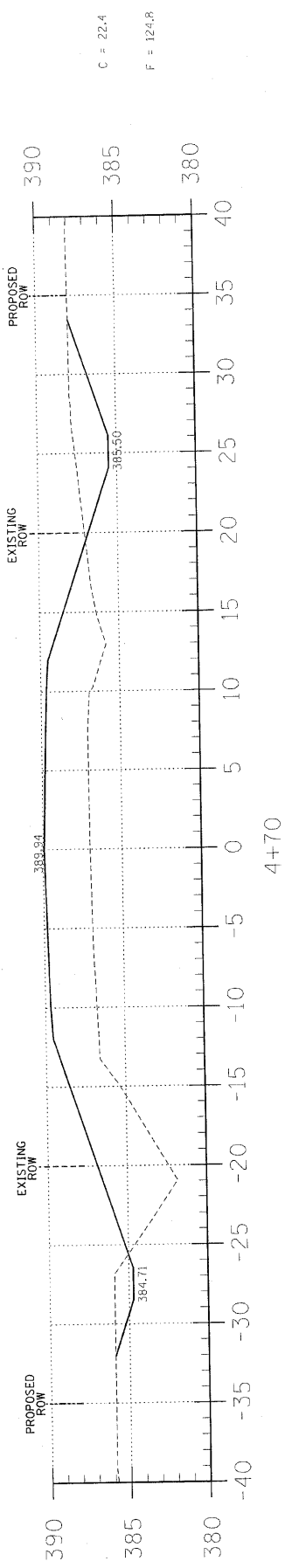

EARTHWORK SCHEDULE

LOCATION	EARTH EXCAVATION	CHANNEL EXCAVATION	ESTIMATED UNSUITABLE MATERIAL	SUITABLE MATERIAL ADJUSTED FOR SHRINKAGE	EMBANKMENT	EARTHWORK BALANCE WASTE (+) OR SHORTAGE (-)
	CUBIC YARD	CUBIC YARD	CUBIC YARD	CUBIC YARD	CUBIC YARD	CUBIC YARD
STA 0+00 TO 4+74.3	129.6	0.0	0.0	97.2	575.5	-478.3
STA 4+74.3 TO 5+25.6	0.0	158.0	79.0	59.3	0.0	59.3
STA 5+25.6 TO 10+00	681.3	0.0	0.0	511.0	1360.5	-849.5
1 FIELD ENTRANCE	0.0	0.0	0.0	0.0	11.5	-11.5
TOTAL	810.9	158.0	79.0	667.5	1947.5	-1280.0

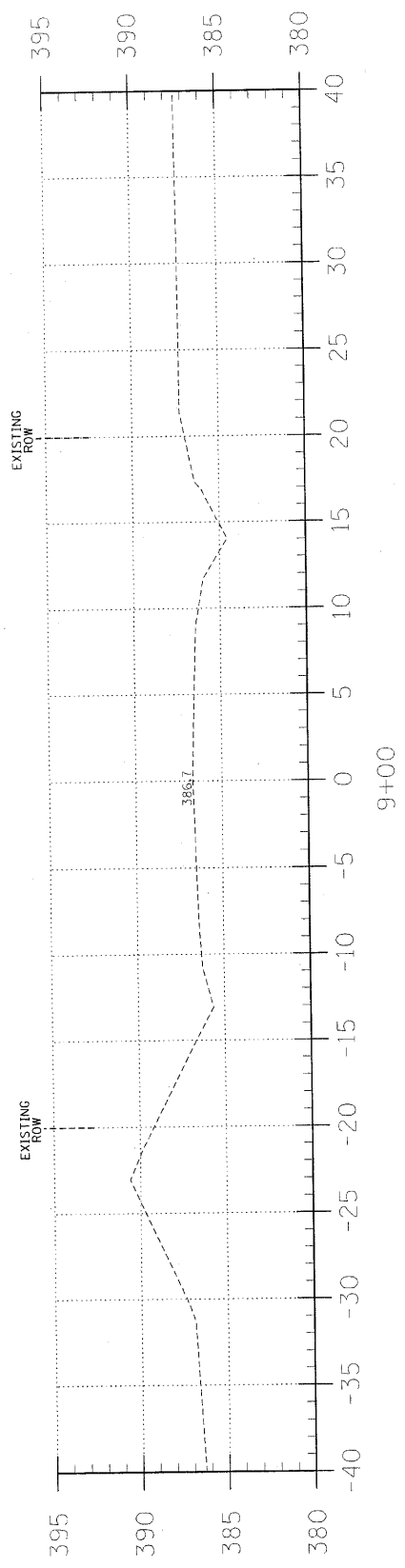

9+00

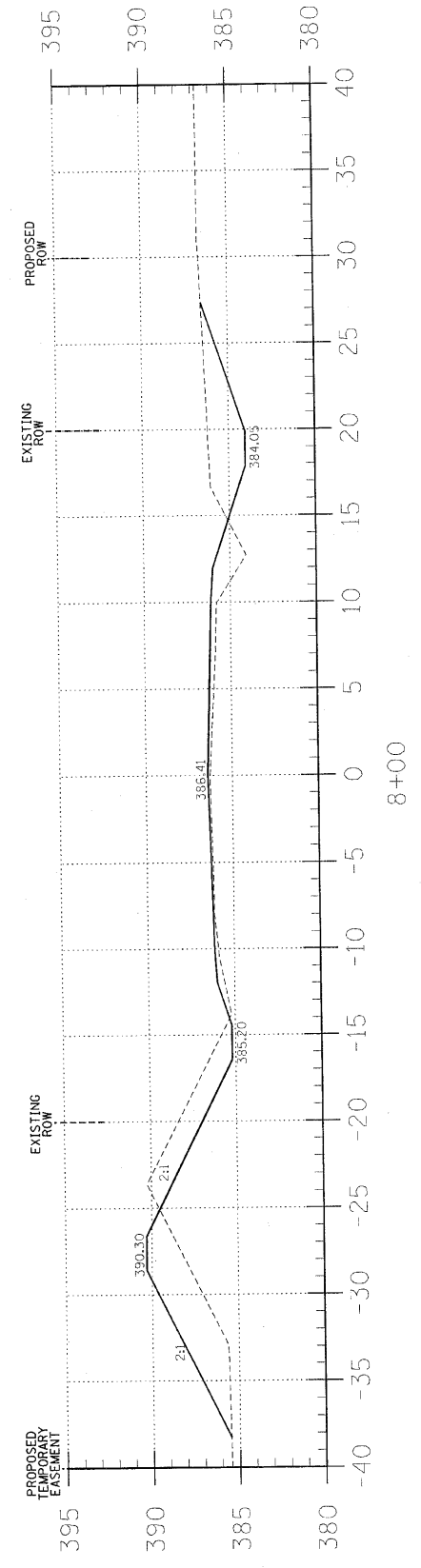

8+00

C = 28.9
F = 32.7

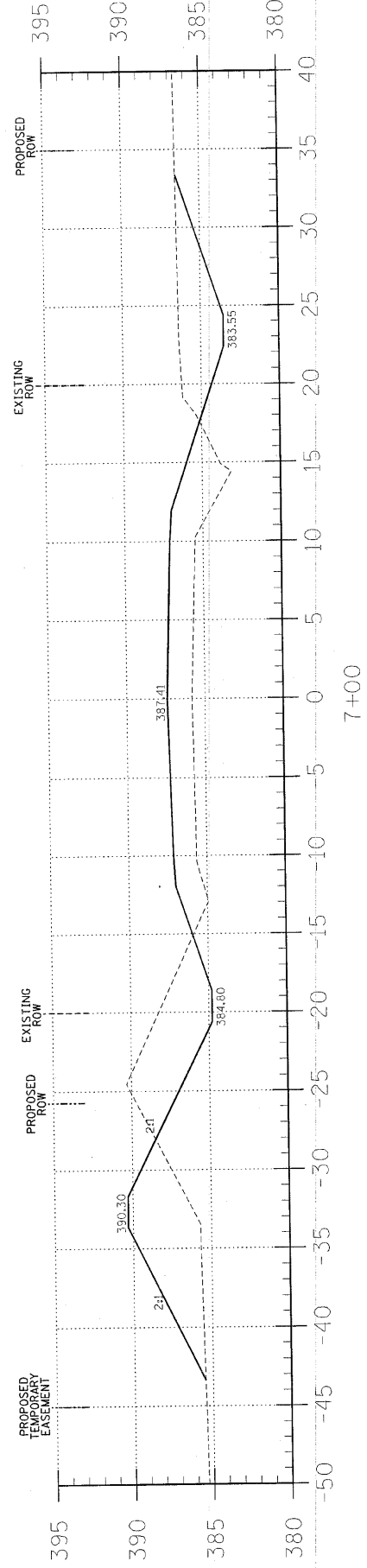

7+00

C = 58.6
F = 90.9

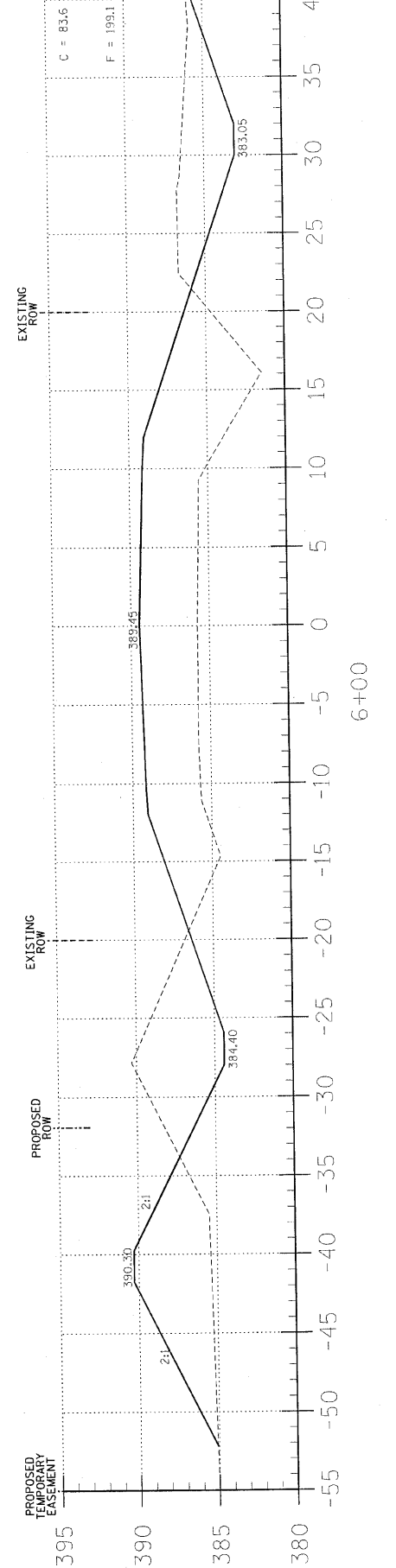

6+00

C = 83.6
F = 199.1

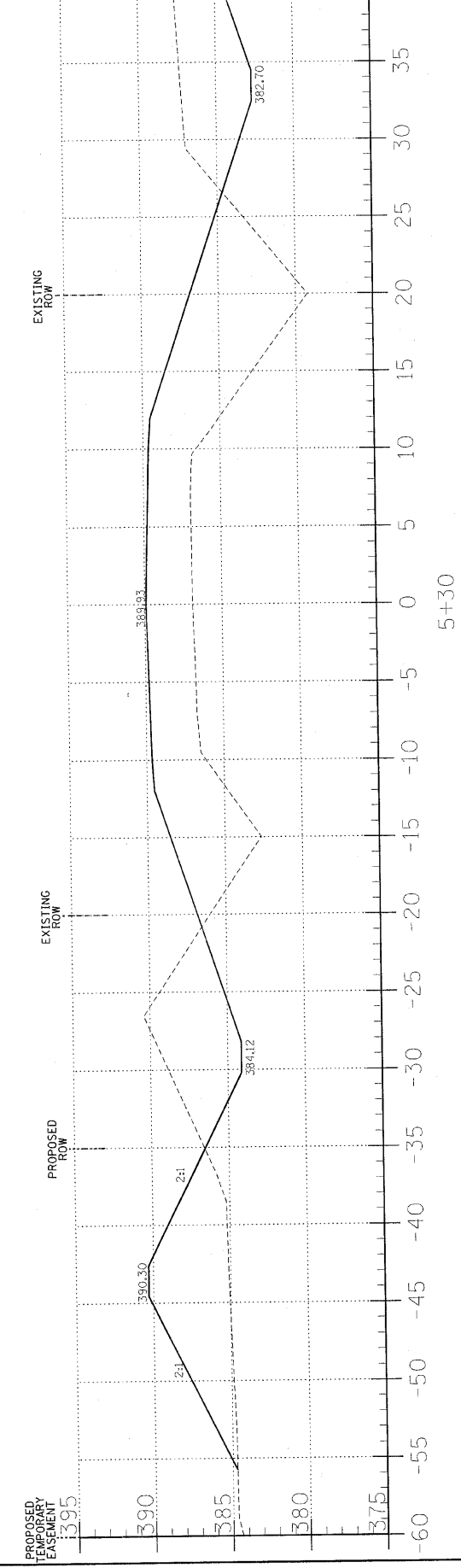

5+30

C = 111.0
F = 243.7

FAS	SECTION	COUNTY	TOTAL SHEETS	SHEET NO.
1884	09-00114-00-BR	WHITE	12	4
FED. ROAD DIST. NO. 9 ILLINOIS		FED. AID PROJECT		
PROJECT# RS-1884(113)		CONTRACT# 99431		
JOB NO. C-99-548-09		ELLIOTT CREEK TRIB.		
LEC JOB # H091006WH				

323 W. 3RD ST.
P.O. BOX 160
MT. CARMEL, IL
62863
PHONE:
(618)-262-8651
FAX:
(618)-263-3327

405 W. STATE ST.
SUITE 1
PRINCETON, IN
47670
PHONE:
(812)-386-7611
FAX:
(812)-385-2812



PROFESSIONAL DESIGN FIRM
LAND SURVEY & PROFESSIONAL ENGINEERING CORPORATION
184-000887
(62-032435)(35-002769)



AARON M. MEFFORD
NAME
Aaron Mefford
SIGNATURE
8-3-10
DATE
11-30-11
EXPIRES

FAS 1884
OVER ELLIOTT CREEK TRIBUTARY
WHITE COUNTY, ILLINOIS

SHEET TITLE:	
CROSS-SECTIONS	
SCALE:	1" = 5'
BY:	AMM
DATE:	8/3/10
REV:	
4	OF 12
SHEETS	
SHEET NO.	
4	

BENCHMARK: Iron Pin Sta. ±4+32.64, 10.75' Rt., Elev. 386.45

EXISTING STRUCTURE NO. 097-3019; Sta. 5+00.5; A single span bridge with concrete deck and curb on wood caps and piling along with wood mudwalls and wingwalls. 20.0' bk.-bk. abuts.; 23.1' o.-o. deck Structure closed to traffic.

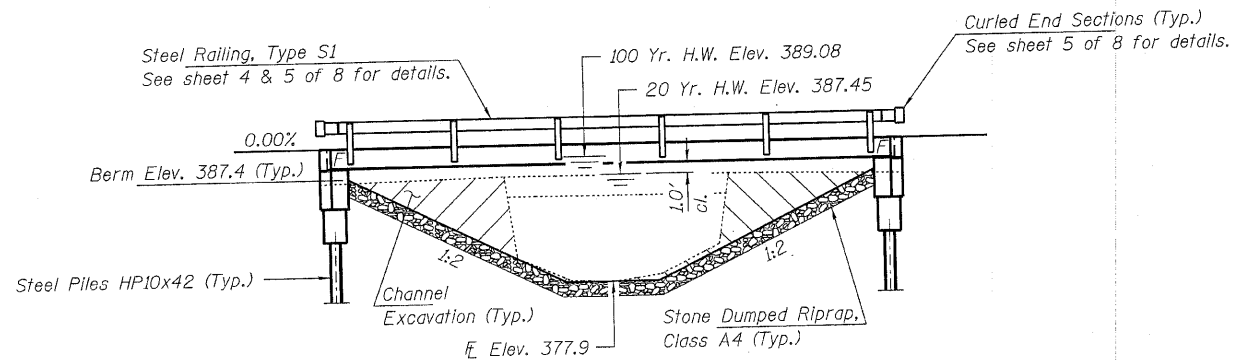

ELEVATION

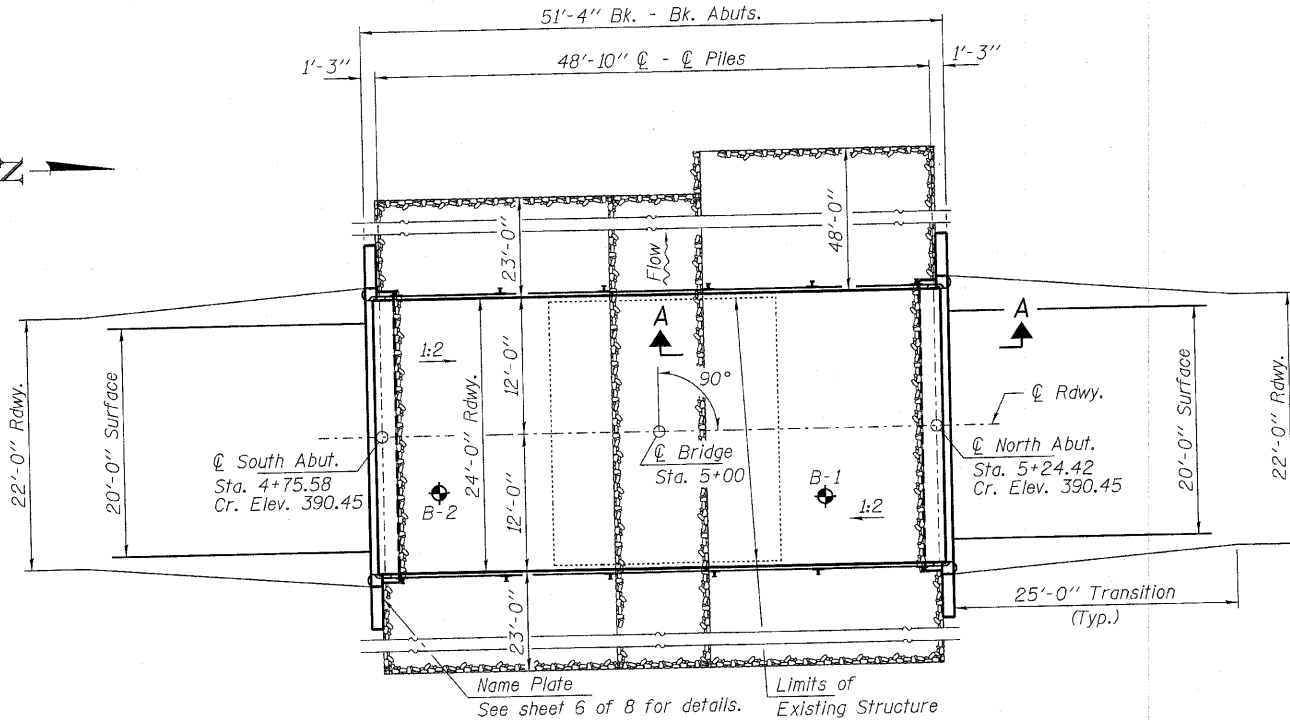

PLAN

DESIGN STRESSES

FIELD UNITS

f'c = 3,500 psi
fy = 60,000 psi (Reinf.)

PRECAST PRESTRESSED UNITS

f'c = 6,000 psi
f'ci = 5,000 psi
fpu = 270,000 psi (1/2" φ low lax. strands)
fpbt = 201,960 psi (1/2" φ low lax. strands)
fy = 60,000 psi (Reinf.)

LOADING HL-93

Design Specifications: 2007 AASHTO LRFD with all applicable interims.
50#/Sq. Ft. included in dead load for future wearing surface.

DESIGNED - A.S.L.
CHECKED - S.W.M.
DRAWN - D.A.B.
CHECKED - S.W.M.

SEISMIC DATA

Seismic Performance Zone (SPZ) = 2
Design Spectral Acceleration at 1.0 sec. (S_{D1}) = 0.284g
Design Spectral Acceleration at 0.2 sec. (S_{D5}) = 0.676g
Soil Site Class = D

WATERWAY INFORMATION

Drainage Area = 2.4 Sq. Mi.		Existing Low Grade Elev. 385.8 @ Sta. 6+00		Proposed Low Grade Elev. 386.4 @ Sta. 8+00		
Flood	Freq. Yr.	Q C.F.S.	Opening Sq. Ft. Exist. Prop.	Natural H.W.E. Exist. Prop.	Head - Ft. Exist. Prop.	Headwater El. Exist. Prop.
Design	20	1360	127 260	387.45 - 0	0 387.45	
Base	100	2180	127 306	389.08 - 0.06	0.32 389.14	389.40
Max. Calc.	500	-	-	-	-	-

GENERAL NOTES

Layout of the slope protection system may be varied to suit ground conditions in the field as directed by the Engineer.
Reinforcement bars shall conform to the requirements of ASTM A 706 Gr 60 (IL Modified). See Special Provisions.
Excavation required to construct the Abutments shall be included in the cost of Concrete Structures. No additional compensation will be allowed for Structure Excavation.
All proposed construction activities shall be in accordance with Nationwide Permit number 14 of the Department of the Army authorized under Section 404 of the Clean Water Act. The IEPA has issued Section 401 Water Quality Certification for this activity. See Special Provisions for conditions.

BUILT 2011 BY
WHITE COUNTY
SEC. 09-00114-00-BR
PHILLIPS ROAD DISTRICT
STR. NO. 097-3268
LOADING HL-93

NAME PLATE
See Std. 515001

INDEX OF STRUCTURE SHEETS

1. General Plan & Elevation
2. Superstructure
- 3-4. Superstructure Details
5. Steel Railing, Type S-1
6. Abutments
7. HP Pile Details
8. Borings

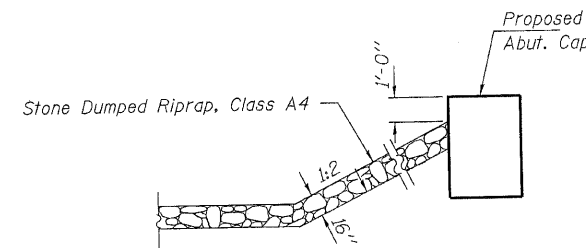

SECTION A-A

Note: See Special Provisions for Stone Dumped Riprap, Class A4.

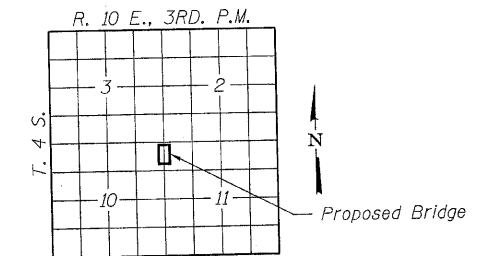

LOCATION SKETCH

TOTAL BILL OF MATERIAL

ITEM	UNIT	SUPER	SUB	TOTAL
Channel Excavation	Cu. Yd.			158
Stone Dumped Riprap, Class A4	Ton			375
Removal of Existing Structures	Each			1
Concrete Structures	Cu. Yd.		22.2	22.2
Concrete Encasement	Cu. Yd.		2.8	2.8
Precast Prestressed Concrete Deck Beams (21" Depth)	Sq. Ft.	1,200		1,200
Reinforcement Bars	Pound		2,420	2,420
Steel Railing, Type S1	Foot	96		96
Furnishing Steel Piles HP10x42	Foot		380	380
Driving Piles	Foot		380	380
Name Plates	Each		1	1

I certify that to the best of my knowledge, information and belief, this bridge design is structurally adequate for the design loading shown on the plans. The design is an economical one for the style of structure and complies with requirements of the current "AASHTO LRFD Specifications."

Steven W. Meckinson 7/27/2010
ILLINOIS STRUCTURAL ENGINEER NO. 081-6064

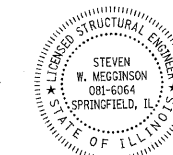

Expires 11-30-2010

GENERAL PLAN AND ELEVATION
STRUCTURE NO. 097-3268

HAMPTON, LENZINI AND RENWICK, INC.
CIVIL ENGINEERS - STRUCTURAL ENGINEERS - LAND SURVEYORS
3085 STEVENSON DRIVE, SUITE 201
SPRINGFIELD, ILLINOIS 62703
217.546.3400 www.hlrengineering.com

184.000959
ILLINOIS PROFESSIONAL DESIGN FIRM LS / PE / SE CORPORATION
PROJECT NUMBER: 09.0053.130 DATE: 07/27/10

SHEET NO. 1 8 SHEETS	F.A.S.	SECTION	COUNTY	TOTAL SHEETS	SHEET NO.
	1884	09-00114-00-BR	WHITE	12	5
FED. ROAD DIST. NO.			ILLINOIS FED. AID PROJECT		
CONTRACT NO. 99431					

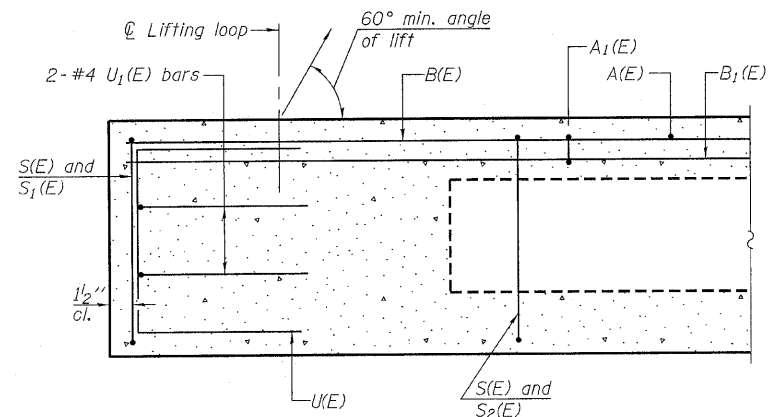

SECTION C-C

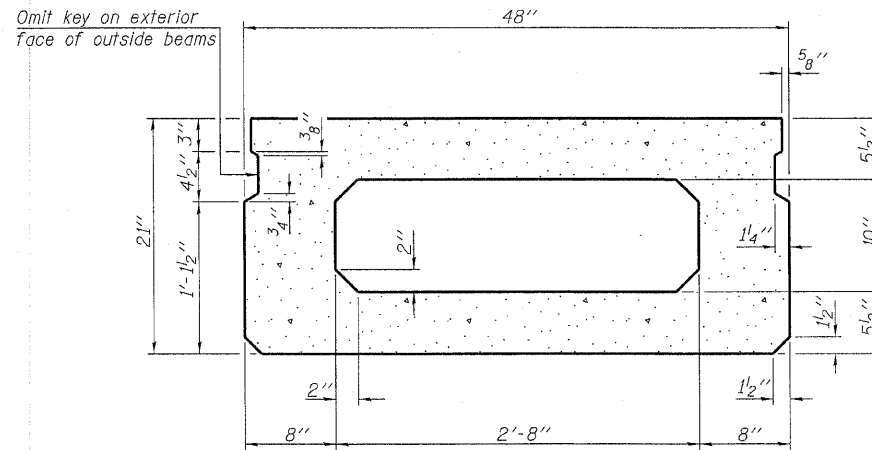

SECTION A-A
(Showing dimensions)

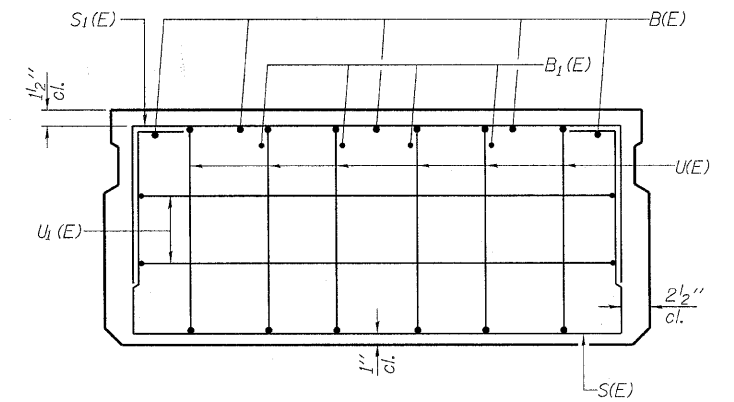

VIEW B-B

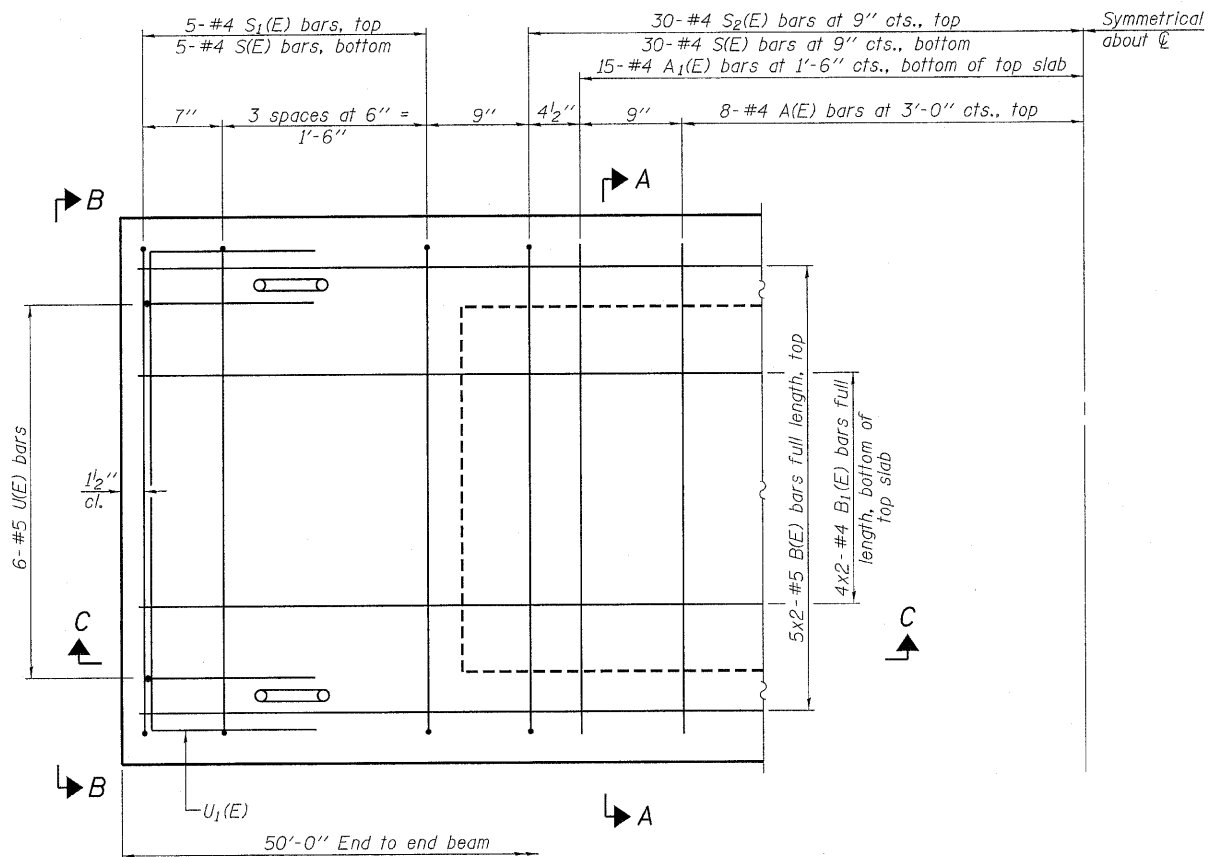

PLAN VIEW

Note:
Spacing of S(E) and S₂(E) bars may be adjusted up to 4" in the immediate area of the transverse tie diaphragms to miss the block outs for the transverse ties.
Bars indicated thus 5x2-#4 etc. indicates 5 lines of bars with 2 lengths per line.

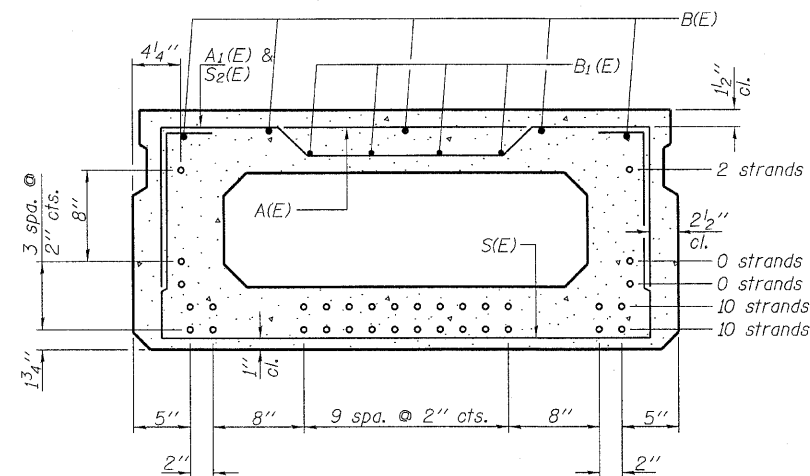

SECTION A-A
(Showing reinforcement and permissible strand locations)

Note: Place the number of strands specified in each row symmetrically about the centerline of beam in the permissible strand locations shown.

BAR LIST
ONE BEAM ONLY
(For Information Only)

Bar	No.	Size	Length	Shape
A(E)	16	#4	3'-7"	—
A ₁ (E)	30	#4	3'-10"	~
B(E)	10	#5	26'-2"	—
B ₁ (E)	8	#4	25'-11"	—
S(E)	70	#4	7'-5"	U
S ₁ (E)	10	#4	5'-11"	U
S ₂ (E)	60	#4	6'-2"	U
U(E)	12	#5	4'-0"	U
U ₁ (E)	4	#4	6'-0"	U

Note: See sheet 3 & 4 of 8 for additional details and Bill of Material.

MINIMUM BAR LAP

#4 bar = 2'-0"
#5 bar = 2'-6"

DESIGNED - A.S.L.
CHECKED - S.W.M.
DRAWN - D.A.B.
CHECKED - S.W.M.

PD-2148-0

11-1-09

HAMPTON, LENZINI AND RENWICK, INC.
CIVIL ENGINEERS • STRUCTURAL ENGINEERS • LAND SURVEYORS
3085 STEVENSON DRIVE, SUITE 201
SPRINGFIELD, ILLINOIS 62703
217.546.3400 www.hlrengineering.com

HLR
184.003959
ILLINOIS PROFESSIONAL DESIGN FIRM LS / PE / SE CORPORATION
PROJECT NUMBER: 09.0053.130 DATE: 07/27/10

SHEET NO. 2
8 SHEETS

F.A.S.	SECTION	COUNTY	TOTAL SHEETS	SHEET NO.
1884	09-00114-00-BR	WHITE	12	6
CONTRACT NO. 99431				
FED. ROAD DIST. NO.		ILLINOIS FED. AID PROJECT		

SUPERSTRUCTURE
21" x 48" PPC DECK BEAM
STRUCTURE NO. 097-3268

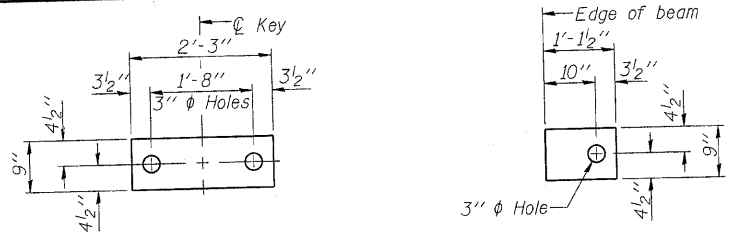

FABRIC BEARING PAD
(Interior - 10 Req'd.)

FABRIC BEARING PAD
(Exterior - 4 Req'd.)

FIXED

Notes:

All bearing pads shall be 1" thick.
Omit holes when using expansion bearings.
Expansion bearing pad shall be bonded to the substructure.

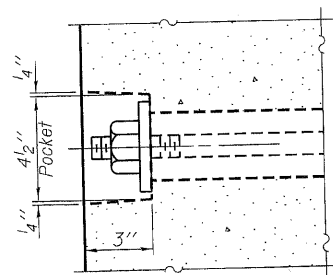

SECTION A-A

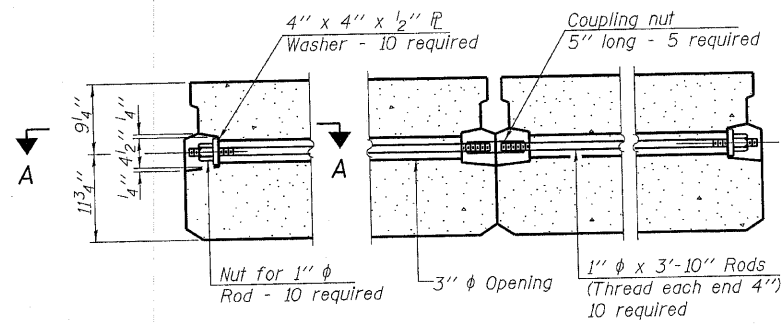

TYPICAL TRANSVERSE TIE ASSEMBLY

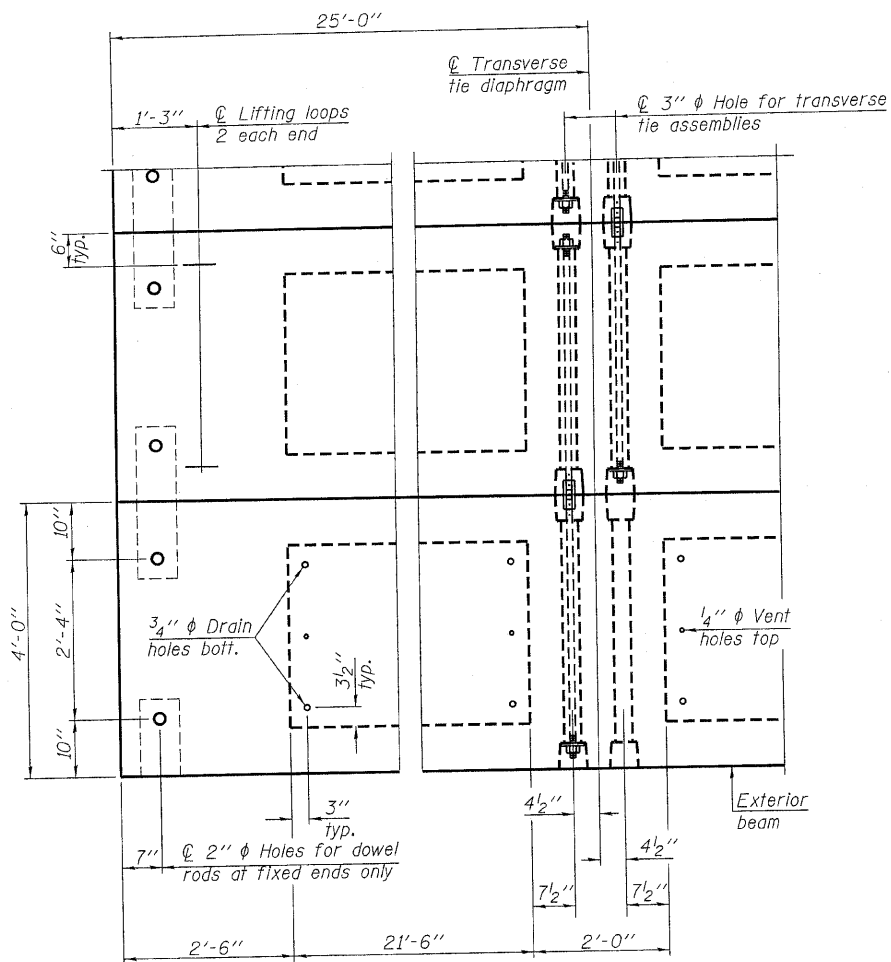

PLAN VIEW

NOTES

Prestressing steel shall be uncoated high strength, low relaxation 7-wire strand, Grade 270. The nominal diameter shall be 1/2" and the nominal cross-sectional area shall be 0.153 sq. in.
The 1" diameter rods in the transverse tie assembly shall be tightened to a snug fit and the threads set. Pockets on exterior faces of bridge shall be filled with grout after transverse tie assembly is in place.
Reinforcement bars shall conform to ASTM A 706, Grade 60. (See Special Provisions).
Two 1/8" fabric adjusting shims of the dimensions of the exterior bearing pad shall be provided for each bearing pad location.
A minimum 2 1/2" diameter lifting pin shall be used to engage the lifting loops during handling.
Corrosion Inhibitor, per Article 1020.05(b)(12) and 1021.06 of the Standard Specifications, shall be used in the concrete for precast prestressed concrete deck beams.
Compressive strength of prestressed concrete, f'c, shall be 6000 psi.
Compressive strength of prestressed concrete at release, f'ci, shall be 5000 psi.
Reinforcement bars designated (E) shall be epoxy coated.

Note: Connect beams in pairs with the transverse tie configuration shown.

DESIGNED - A.S.L.
CHECKED - S.W.M.
DRAWN - D.A.B.
CHECKED - S.W.M.

PD-2148-0D 11-1-09

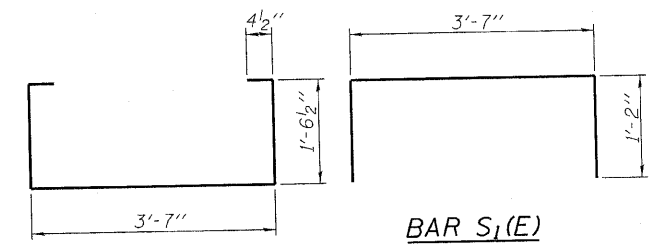

BAR S(E)

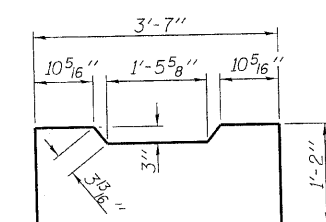

BAR U(E)

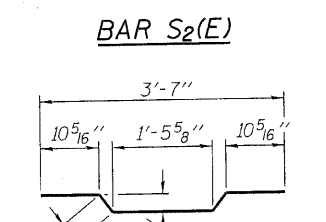

BAR S2(E)

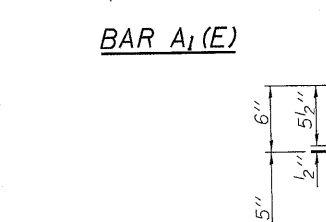

BAR A1(E)

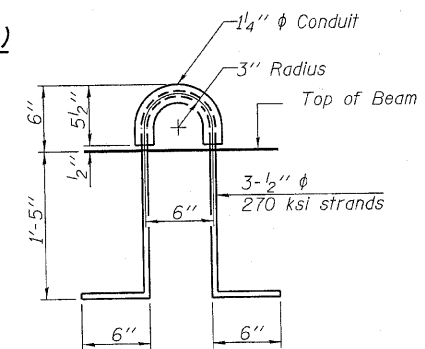

LIFTING LOOP DETAIL

BILL OF MATERIAL

Precast Prestressed Conc. Deck Bms. (21" depth)	Sq. Ft.	1,200
-------------------------------------------------	---------	-------

SUPERSTRUCTURE DETAILS
21" x 48" PPC DECK BEAM DETAILS
STRUCTURE NO. 097-3268

HAMPTON, LENZINI AND RENWICK, INC. CIVIL ENGINEERS - STRUCTURAL ENGINEERS - LAND SURVEYORS 3085 STEVENSON DRIVE, SUITE 201 SPRINGFIELD, ILLINOIS 62703 217.546.3400 www.hirengineering.com 154.000996 ILLINOIS PROFESSIONAL DESIGN FIRM LS / PE / SE CORPORATION PROJECT NUMBER: 09.0053.130 DATE: 07/27/10	SHEET NO. 3 8 SHEETS	F.A.S.	SECTION	COUNTY	TOTAL SHEETS	SHEET NO.
		1884	09-00114-00-BR	WHITE	12	7
		CONTRACT NO. 99431				
		FED. ROAD DIST. NO.	ILLINOIS FED. AID PROJECT			

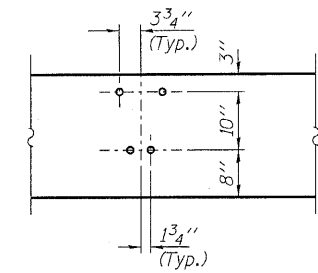
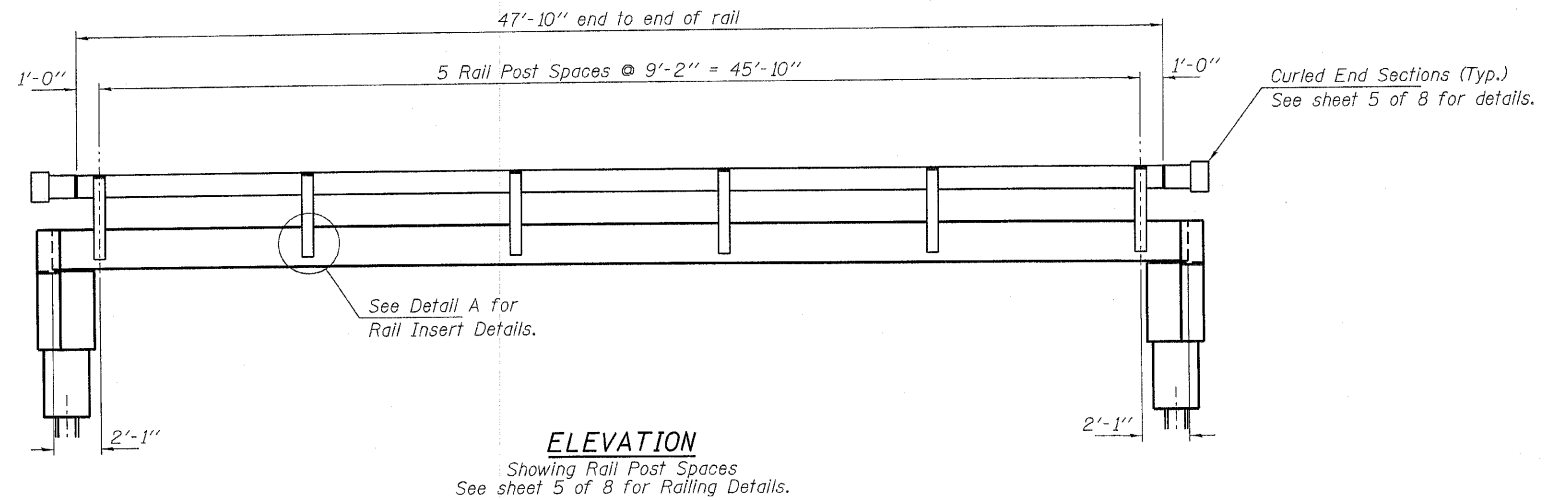

DETAIL A

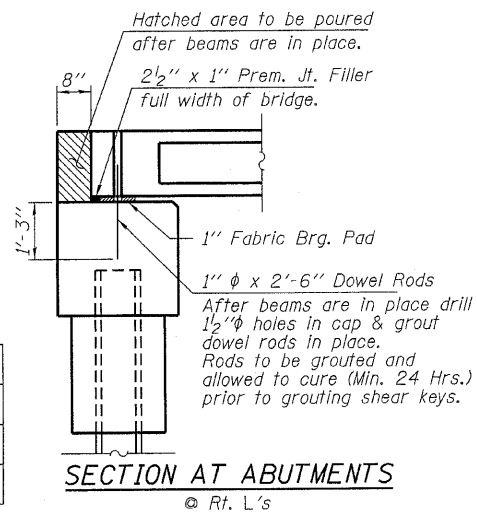
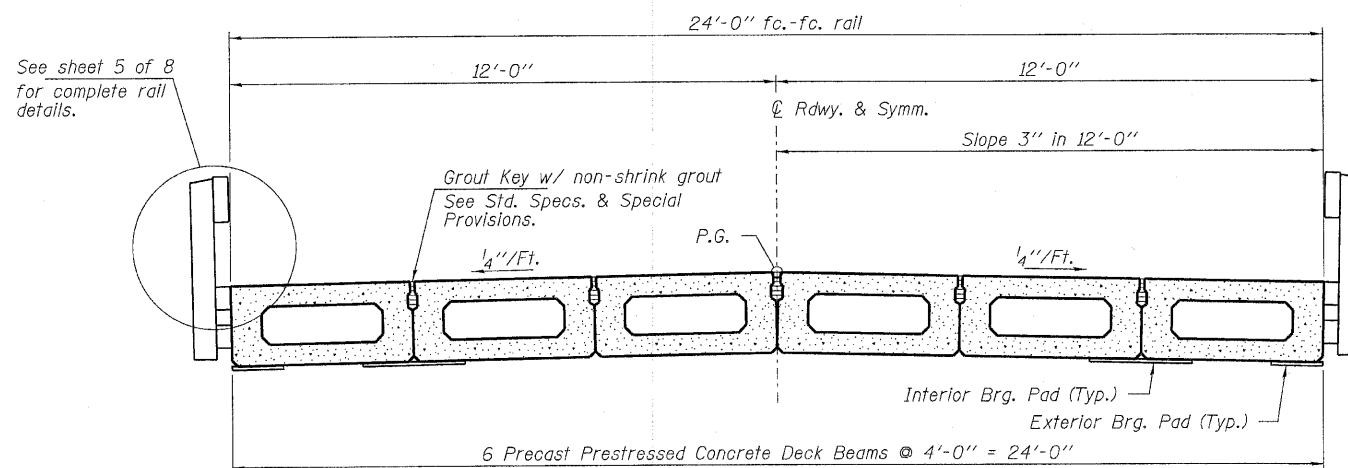

DESIGNED - A.S.L.
CHECKED - S.W.M.
DRAWN - D.A.B.
CHECKED - S.W.M.

SUPERSTRUCTURE DETAILS
STRUCTURE NO. 097-3268

HLR 184.000959 ILLINOIS PROFESSIONAL DESIGN FIRM LS / PE / SE CORPORATION PROJECT NUMBER: 09.0053.130 DATE: 07/27/10	HAMPTON, LENZINI AND RENWICK, INC. CIVIL ENGINEERS - STRUCTURAL ENGINEERS - LAND SURVEYORS 3085 STEVENSON DRIVE, SUITE 201 SPRINGFIELD, ILLINOIS 62703 217.546.3400 www.hlrenw.com		F.A.S.	SECTION	COUNTY	TOTAL SHEETS	SHEET NO.
	SHEET NO. 4 8 SHEETS	1884	09-00114-00-BR	WHITE	12	8	
			FED. ROAD DIST. NO.		ILLINOIS FED. AID PROJECT		
CONTRACT NO. 99431							

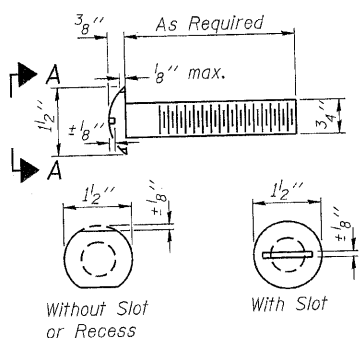

**VIEW A-A
ROUND HEAD BOLT**

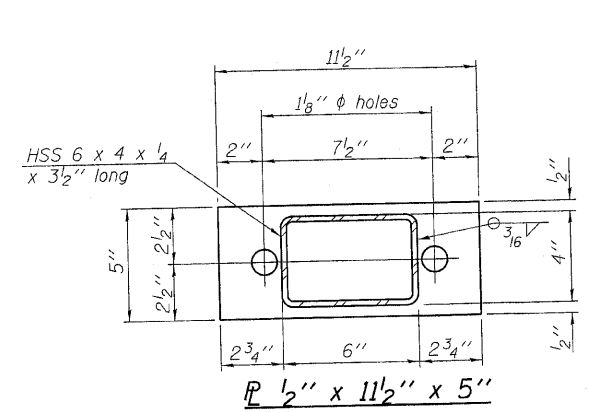

SECTION B-B

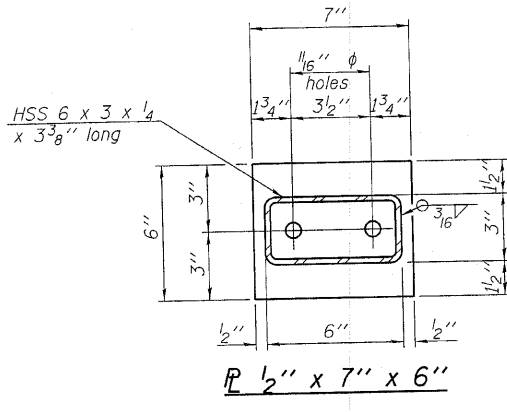

SECTION AT RAILING POST

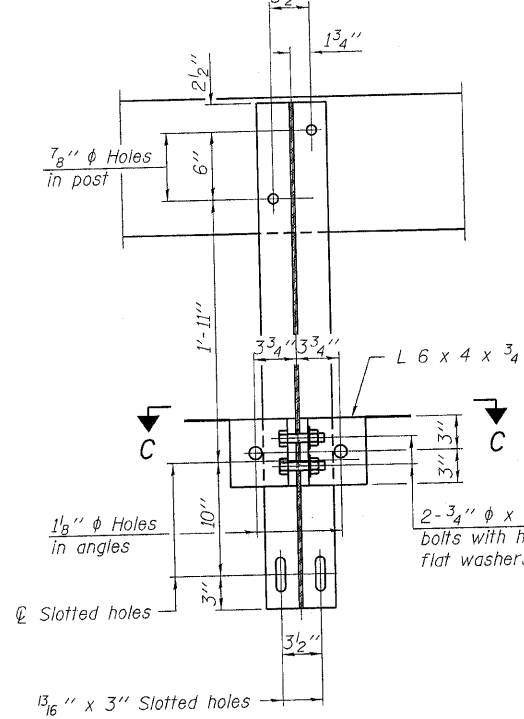

SECTION C-C

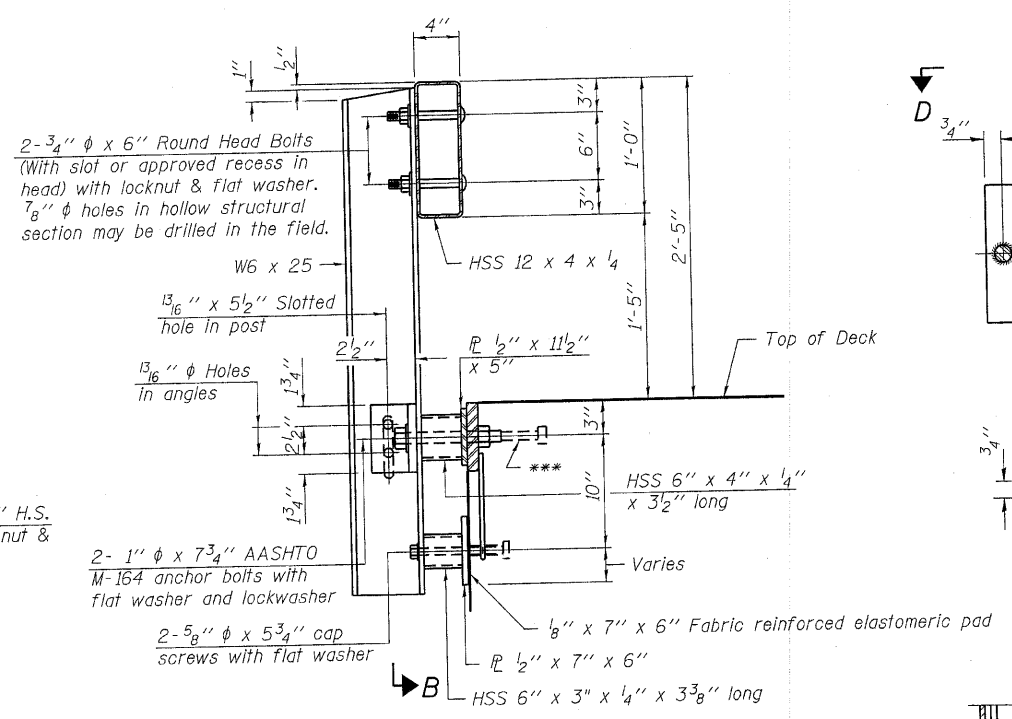

SECTIONS AT RAIL SPLICE

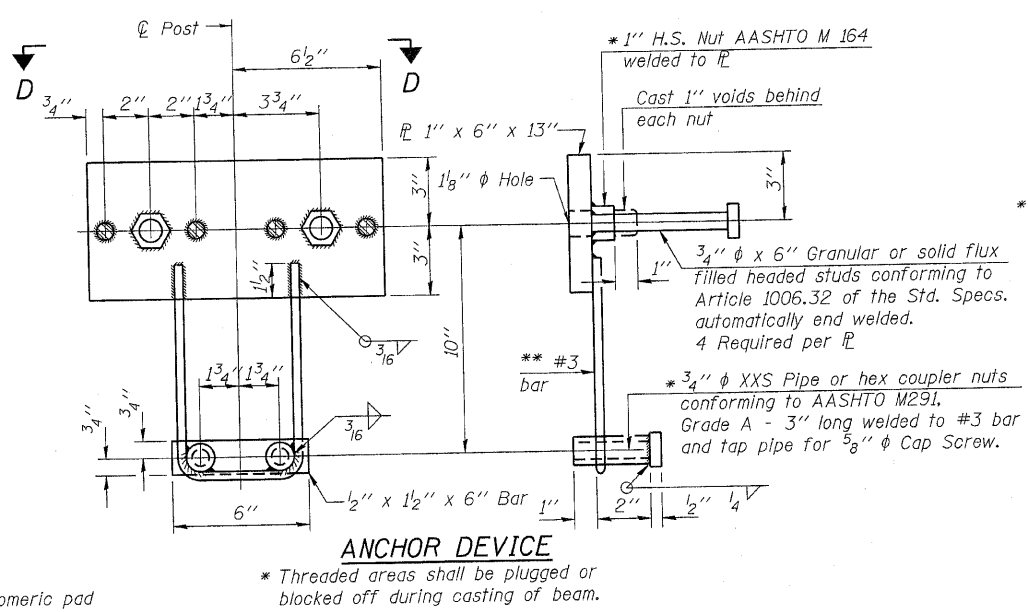

ANCHOR DEVICE

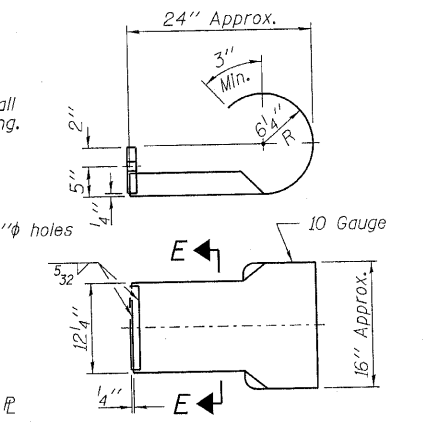

SECTION E-E CURLED END SECTION DETAILS

Note: Cost of curled end sections shall be included with the Steel Railing. (4 Required)

Notes:
All field drilled holes shall be coated with an approved zinc rich paint before erection.
For multi-span bridges, sufficient 1/4" x 6" x 1'-2" galvanized steel shims shall be provided to align rail between adjacent spans. Cost included with Steel Railing, Type S-1.
All steel rail elements shall be galvanized according to Article 509.05 of the Standard Specifications.
The studs of the anchor devices shall be placed below the top reinforcement bars and the outermost longitudinal reinforcement bar shall be placed directly above the studs of the rail post anchor device.

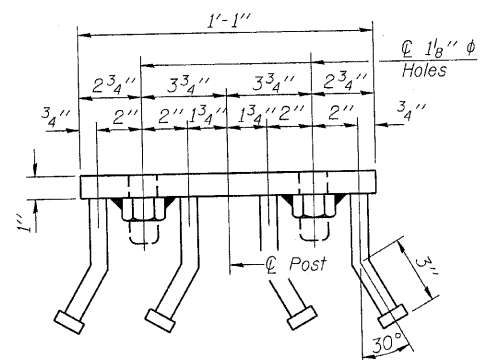

VIEW D-D

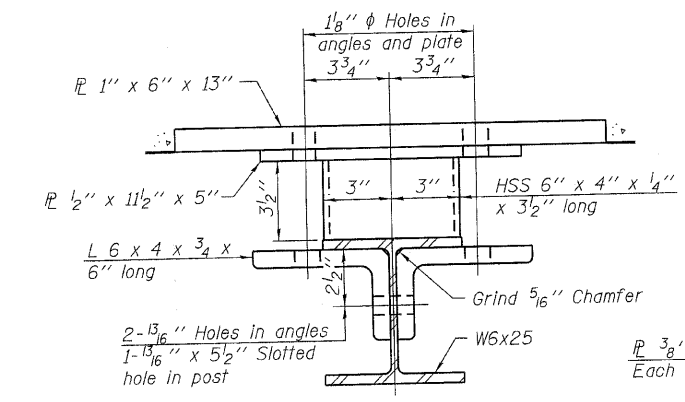

SECTION C-C

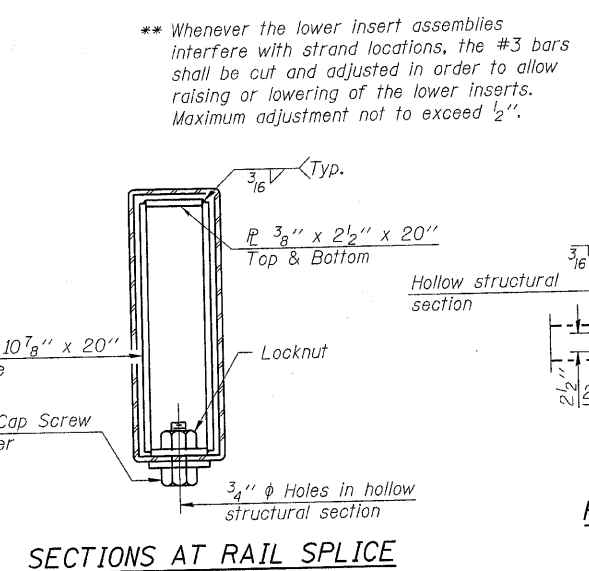

SECTIONS AT RAIL SPLICE

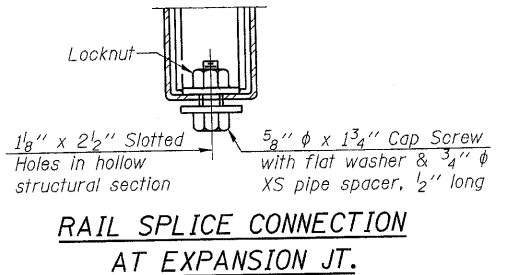

RAIL SPLICE CONNECTION AT EXPANSION JT.

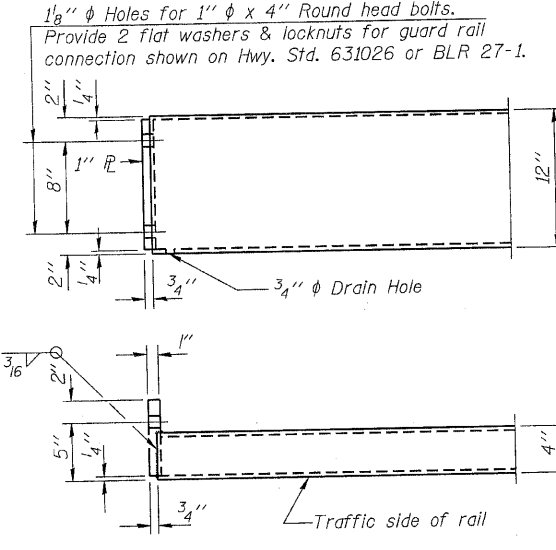

END OF RAIL DETAILS

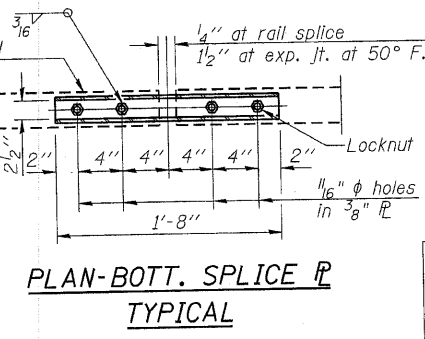

PLAN-BOTT. SPLICE RAIL TYPICAL

BILL OF MATERIAL

Item	Unit	Quantity
Steel Railing, Type S-1	Foot	96

**STEEL RAILING, TYPE S-1
STRUCTURE NO. 097-3268**

DESIGNED - A.S.L.
CHECKED - S.W.M.
DRAWN - D.A.B.
CHECKED - S.W.M.

R-23A

11-1-09 (10'-9" Maximum Post Spacing)

HAMPTON, LENZINI AND RENWICK, INC.
CIVIL ENGINEERS • STRUCTURAL ENGINEERS • LAND SURVEYORS
3085 STEVENSON DRIVE, SUITE 201
SPRINGFIELD, ILLINOIS 62703
217.546.3400 www.hlrengineering.com

184.000959
ILLINOIS PROFESSIONAL DESIGN FIRM LS / PE / SE CORPORATION
PROJECT NUMBER: 09.0053.130 DATE: 07/27/10

SHEET NO. 5 8 SHEETS	F.A.S.	SECTION	COUNTY	TOTAL SHEETS	SHEET NO.
	1884	09-00114-00-BR	WHITE	12	9
FED. ROAD DIST. NO.		ILLINOIS FED. AID PROJECT		CONTRACT NO. 99431	

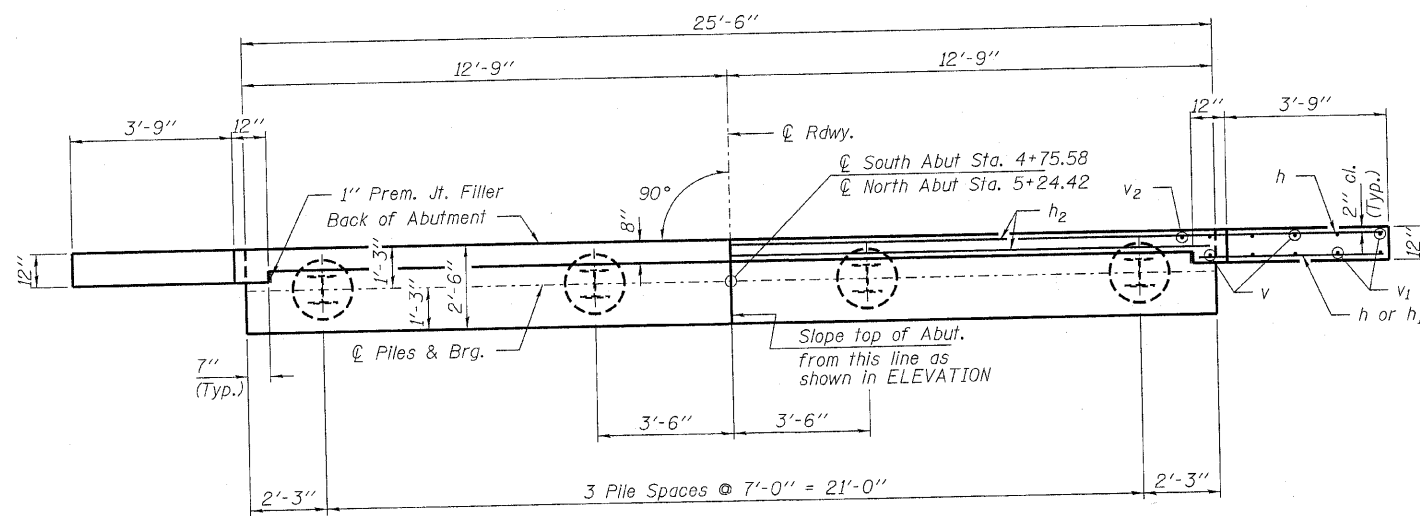

PLAN

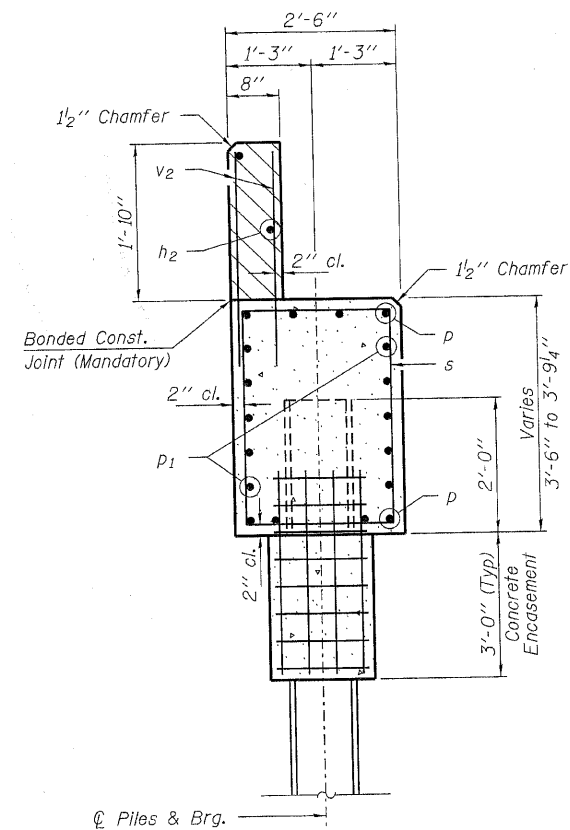

SECTION A-A

Hatched area to be poured after beams are in place.

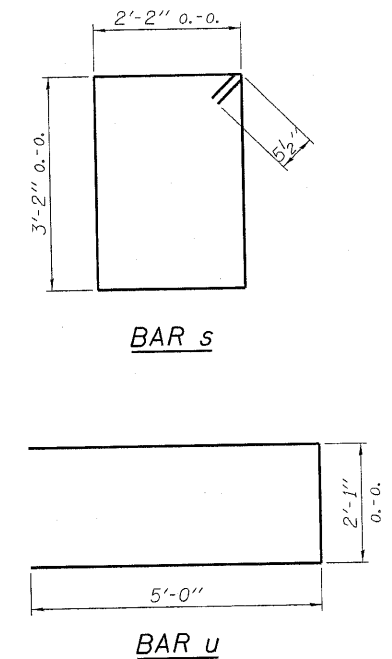

BAR s

BAR u

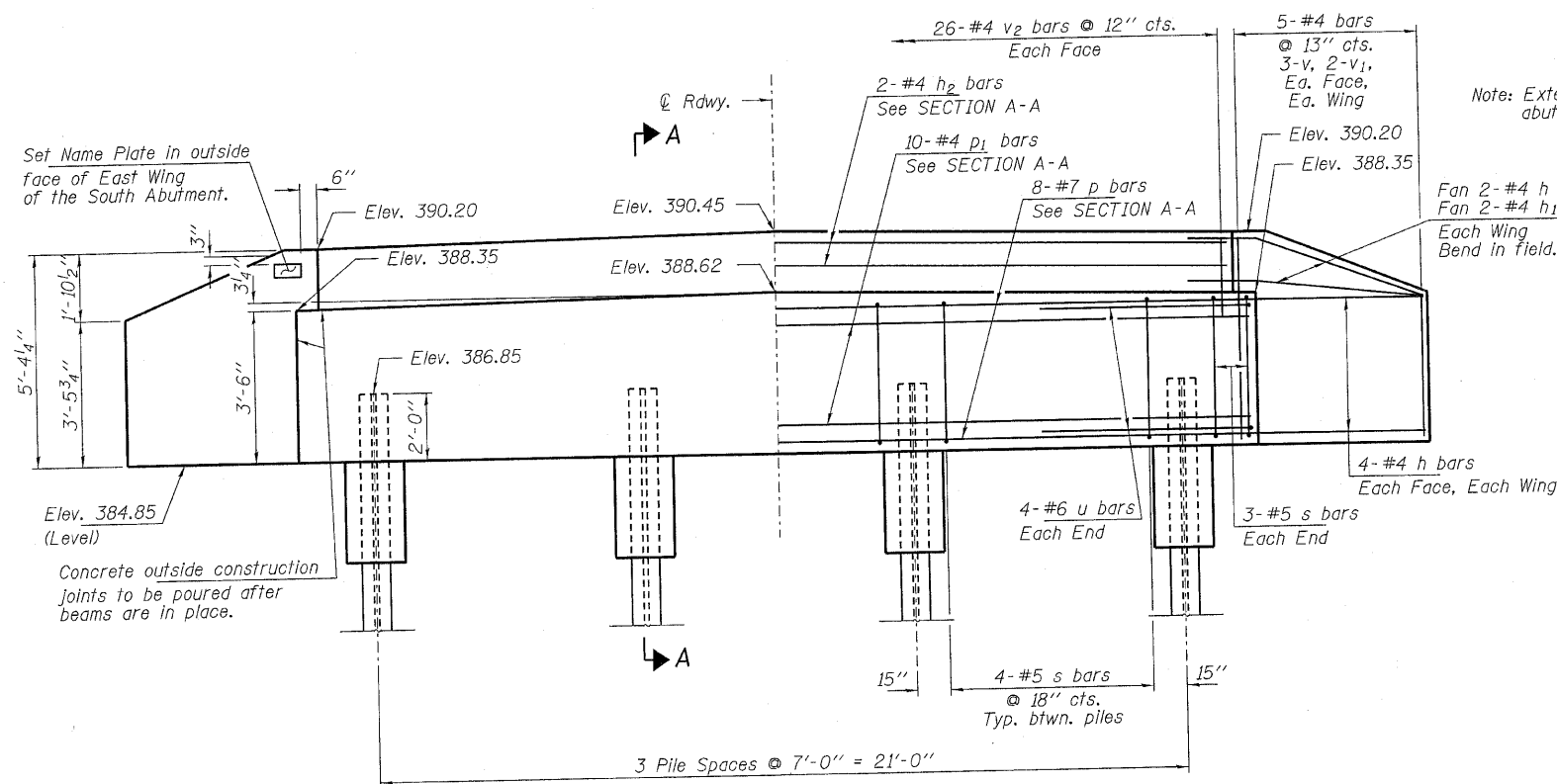

ELEVATION

Note: Extend h bars into abutment cap.

Each Wing Bend in field.

PILE DATA

Type Steel HP10x42
 No. Req'd. (2 Abuts.) 8
 Factored Resistance Available (RT) 167 Kips/Pile
 Nominal Required Bearing (Rn) 335 Kips/Pile
 Est. Length 45 Ft./Pile - S. Abut.
 50 Ft./Pile - N. Abut.

Notes: The Steel H-Piles shall be according to AASHTO M270 Grade 50.

BILL OF MATERIAL - 2 ABUTS.

BAR	NO.	SIZE	LENGTH	SHAPE
h	40	#4	6'-0"	—
h1	8	#4	4'-6"	—
h2	4	#4	25'-2"	—
p	16	#7	25'-2"	—
p1	20	#4	25'-2"	—
s	36	#5	11'-7"	□
u	16	#6	12'-1"	U
v	24	#4	4'-3"	—
v1	16	#4	3'-3"	—
v2	104	#4	2'-8"	—
Concrete Structures			Cu. Yd.	22.2
Concrete Encasement			Cu. Yd.	2.8
Reinforcement Bars			Pound	2,420
Steel Piles HP10x42			Foot	380
Name Plates			Each	1

ABUTMENTS
 STRUCTURE NO. 097-3268

DESIGNED - A.S.L.
CHECKED - S.W.M.
DRAWN - D.A.B.
CHECKED - S.W.M.

HAMPTON, LENZINI AND RENWICK, INC.
 CIVIL ENGINEERS • STRUCTURAL ENGINEERS • LAND SURVEYORS
 3085 STEVENSON DRIVE, SUITE 201
 SPRINGFIELD, ILLINOIS 62703
 217.546.3400 www.hlrengineering.com

184 000959
 ILLINOIS PROFESSIONAL DESIGN FIRM LS / PE / SE CORPORATION

PROJECT NUMBER: 09.0053.130 DATE: 07/27/10

SHEET NO. 6	F.A.S.	SECTION	COUNTY	TOTAL SHEETS	SHEET NO.
	1884	09-00114-00-BR	WHITE	12	10
8 SHEETS	CONTRACT NO. 99431				
FED. ROAD DIST. NO.		ILLINOIS	FED. AID PROJECT		

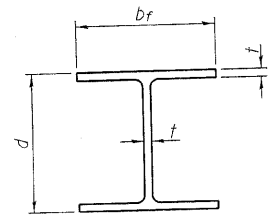

STEEL PILE TABLE

Designation	Depth d	Flange width b _f	Web and Flange thickness t	Encasement diameter A
HP 14x117	14 1/4"	14 7/8"	13/16"	30"
x102	14"	14 3/4"	1/16"	30"
x89	13 7/8"	14 3/4"	5/8"	30"
x73	13 5/8"	14 5/8"	1/2"	30"
HP 12x84	12 1/4"	12 1/4"	1/16"	24"
x74	12 1/8"	12 1/4"	5/8"	24"
x63	12"	12 1/8"	1/2"	24"
x53	11 3/4"	12"	7/16"	24"
HP 10x57	10"	10 1/4"	9/16"	24"
x42	9 3/4"	10 1/8"	7/16"	24"
HP 8x36	8"	8 1/8"	7/16"	18"

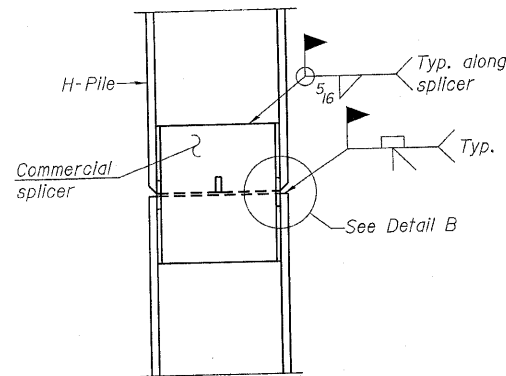

ELEVATION

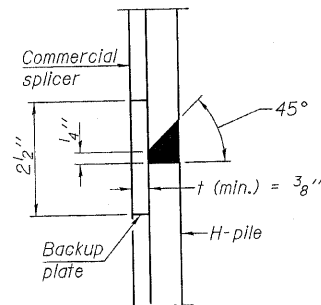

DETAIL "B"

WELDED COMMERCIAL SPLICE

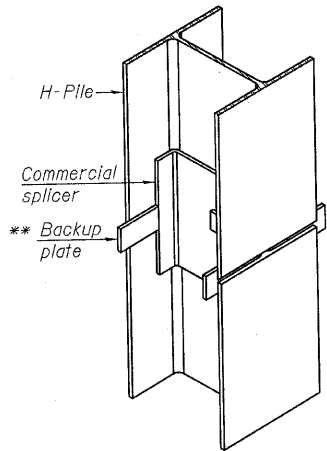

ISOMETRIC VIEW

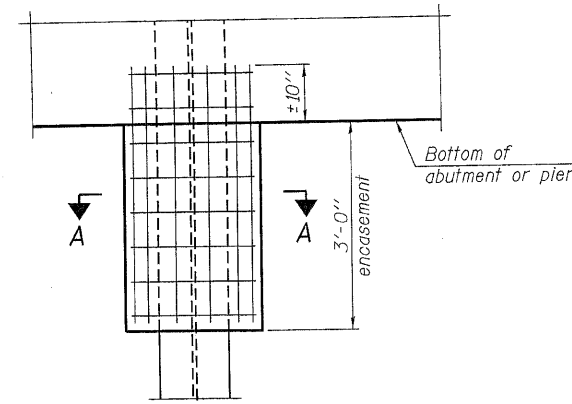

ELEVATION

PILE ENCASEMENT

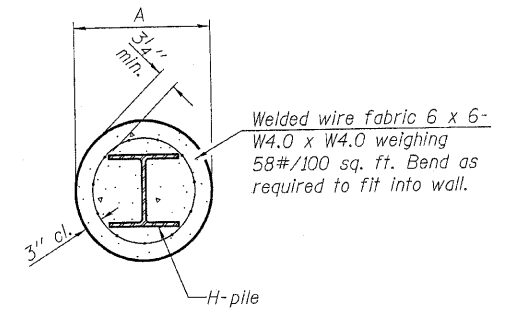

SECTION A-A

Note:
Forms for encasement may be omitted when soil conditions permit.

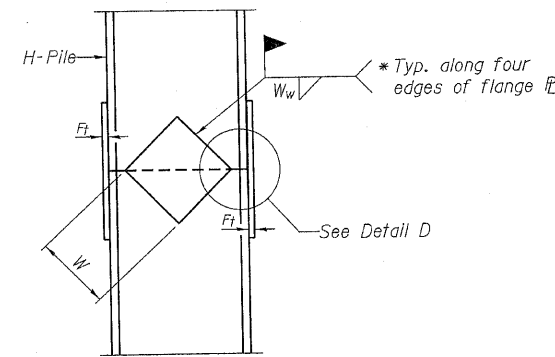

ELEVATION

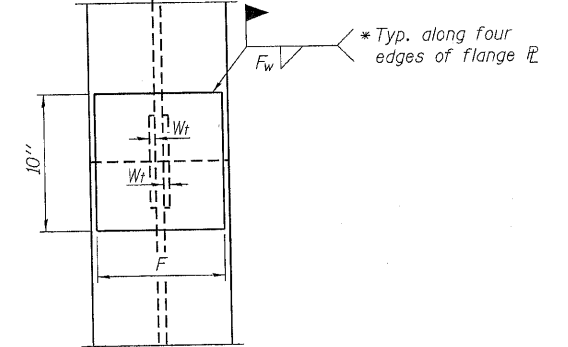

END VIEW

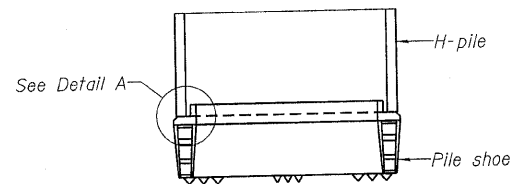

ELEVATION

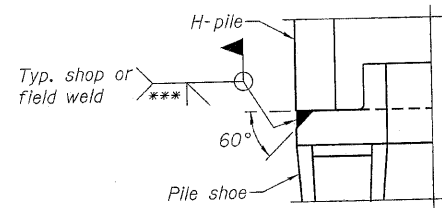

DETAIL A

H-PILE SHOE ATTACHMENT

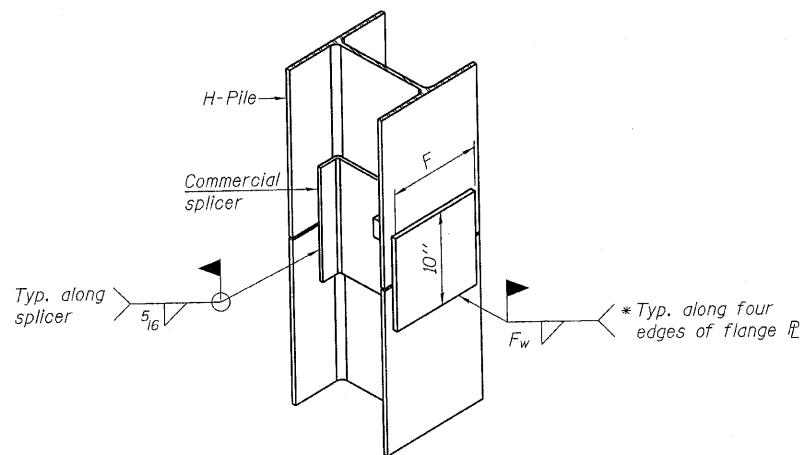

ISOMETRIC VIEW

WELDED COMMERCIAL SPLICE ALTERNATE

- * Interrupt welds 1/4" from end of web and/or each flange.
- ** Remove portions of backup plates that extend outside the flanges.
- *** Weld size per pile shoe manufacturer (5/16" min.).

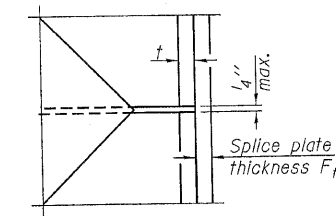

DETAIL D

WELDED PLATE FIELD SPLICE

Designation	F	F _t	F _w	W	W _t	W _w
HP 14x117	12 1/2"	1"	7/8"	7 3/4"	5 8/8"	1/2"
x102	12 1/2"	7/8"	3/4"	7 3/4"	5 8/8"	1/2"
x89	12 1/2"	3/4"	1/16"	7 3/4"	5 8/8"	1/2"
x73	12 1/2"	5/8"	9/16"	7 3/4"	5 8/8"	1/2"
HP 12x84	10"	7/8"	1/16"	6 1/2"	5 8/8"	1/2"
x74	10"	7/8"	1/16"	6 1/2"	5 8/8"	1/2"
x63	10"	5/8"	1/2"	6 1/2"	1/2"	3/8"
x53	10"	5/8"	1/2"	6 1/2"	1/2"	3/8"
HP 10x57	8"	3/4"	9/16"	5 1/4"	1/2"	3/8"
x42	8"	5/8"	9/16"	5 1/4"	1/2"	3/8"
HP 8x36	7"	5/8"	7/16"	4 1/4"	1/2"	3/8"

Note:
The steel H-piles shall be according to AASHTO M270 Grade 50.

**HP PILE DETAILS
STRUCTURE NO. 097-3268**

DESIGNED - A.S.L.
CHECKED - S.W.M.
DRAWN - D.A.B.
CHECKED - S.W.M.

F-HP

11-1-09

HAMPTON, LENZINI AND RENWICK, INC. CIVIL ENGINEERS - STRUCTURAL ENGINEERS - LAND SURVEYORS 3085 STEVENSON DRIVE, SUITE 201 SPRINGFIELD, ILLINOIS 62703 217.546.3400 www.hlrenwicking.com ILLINOIS PROFESSIONAL DESIGN FIRM LS / PE / SE CORPORATION PROJECT NUMBER: 09.0053.130 DATE: 07/27/10	SHEET NO. 7	F.A.S.	SECTION	COUNTY	TOTAL SHEETS	SHEET NO.
	8 SHEETS	1884	09-00114-00-BR	WHITE	12	11
			CONTRACT NO. 99431			
			FED. ROAD DIST. NO.	ILLINOIS FED. AID PROJECT		

