

STATE OF ILLINOIS
DEPARTMENT OF TRANSPORTATION

* Granular or solid flux filled headed studs conforming to Article 1006.32 of the Std. Specs., automatically end welded.

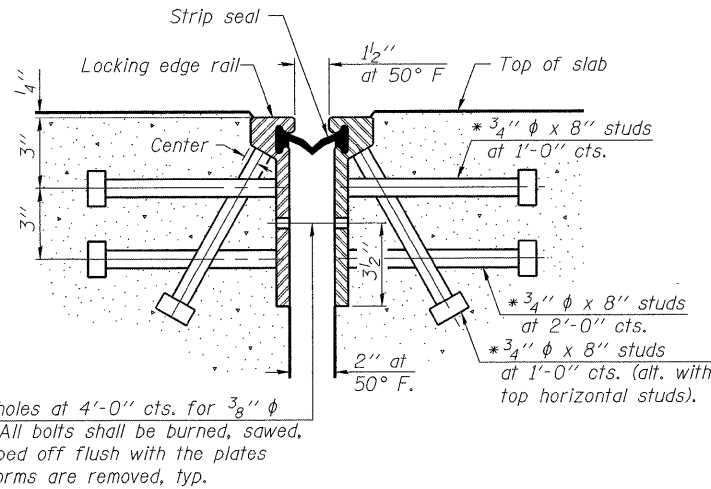

SECTION THRU
ROLLED RAIL JOINT

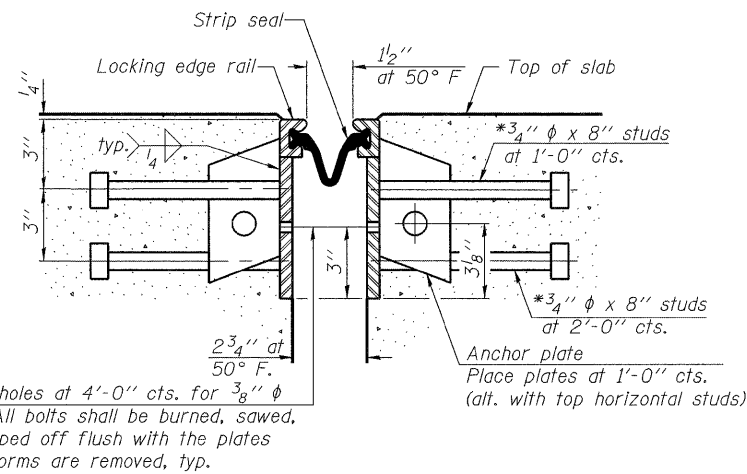

SECTION THRU
WELDED RAIL JOINT

Notes:
The strip seal shall be made continuous and shall have a minimum thickness of 1/4". The configuration of the strip seal shall match the configuration of the Locking Edge Rails. Open or "webbed" strip seal gland configurations are not permitted. The gland shall be sized for a maximum rated movement of 4 inches.
The height and thickness of the Locking Edge Rails shown are minimum dimensions. The actual configuration of the Locking Edge Rails and matching strip seal may vary from manufacturer to manufacturer. Flanged edge rails will not be allowed. Locking Edge Rails may be spliced at slope discontinuities and stage construction joints.
The manufacturer's recommended installation methods shall be followed. The joint opening and deck dimensions detailed on the superstructure are based on a rolled rail expansion joint. If the Contractor elects to use the welded rail expansion joint, the opening and deck dimensions shall be modified according to the dimensions detailed on this sheet. Required modifications shall be made at no additional cost to the State.
All steel components shall be galvanized after fabrication according to Article 520.03 of the Standard Specifications.

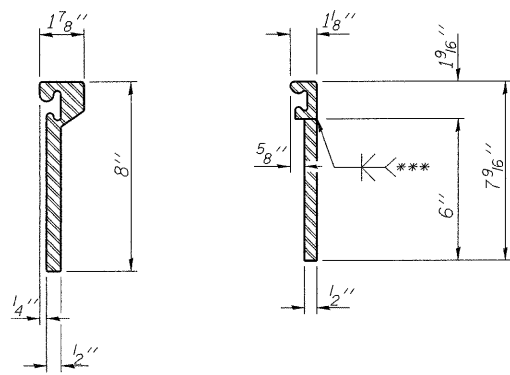

ROLLED
EXTRUDED RAIL WELDED RAIL

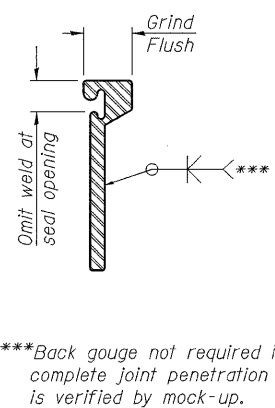

LOCKING EDGE
RAIL SPLICE

The inside of the locking edge rail groove shall be free of weld residue.

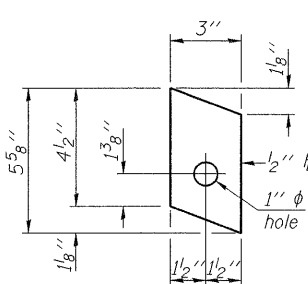

ANCHOR PLATE
(for welded rail)

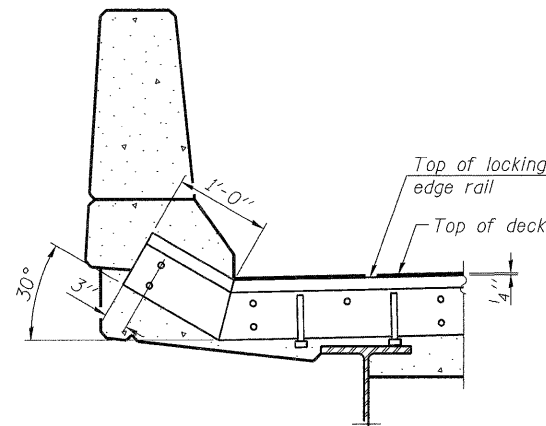

AT PARAPET

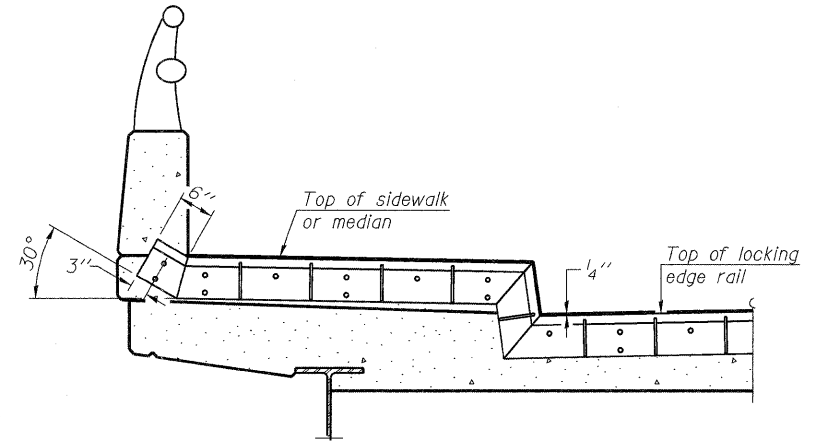

AT SIDEWALK OR MEDIAN

Shorter plates with a single row of studs at 12" cts. may be necessary on medians which are shallower than 9". See manufacturer's recommendation.

TYPICAL END TREATMENTS

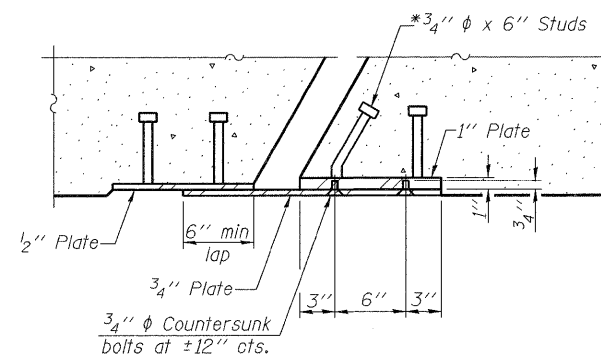

SECTION B-B

BILL OF MATERIAL

| Item | Unit | Total |
|----------------------------|------|-------|
| Preformed Joint Strip Seal | Foot | 86 |

LOCKING EDGE RAILS

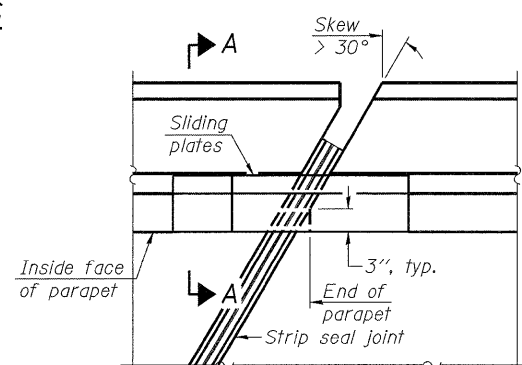

PLAN

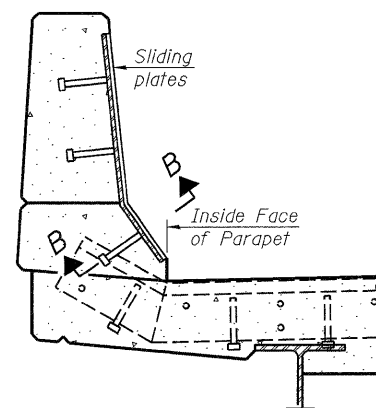

SECTION A-A

POINT BLOCK DETAILS
(for skews > 30°)

| | |
|----------|-------------|
| DESIGNED | SK/GMK/LCM |
| CHECKED | GBC/GMK/SMK |
| DRAWN | RR/LCM/SK |
| CHECKED | GBC/GMK/SMK |

EJ-SSJ

10-1-08

PREFORMED JOINT STRIP SEAL
SOUTHBOUND ILLINOIS ROUTE 394 OVER PLUM CREEK
STATION 20+07.55

| | | | | | |
|---|--------------------|----------------------|--------------------|---------------------|------------------|
| SHEET NO. 10 23 SHEETS | F.A.P. RTE. 332 | SECTION 2002-113R | COUNTY WILL | TOTAL SHEETS 242 | SHEET NO. 181 |
| | SN-099-0183 | | CONTRACT NO. 62542 | | |
| FED. ROAD DIST. NO. 1 ILLINOIS FED. AID PROJECT | | | | | |

DEI Delta Engineering, Inc.
CONSULTING ENGINEERS, CONSTRUCTION MANAGERS, SURVEYORS
111 N. Jackson Blvd., Suite 210 Chicago, IL 60604-2003