

NOTE:
 WHEN MILLING OPERATIONS PRODUCE A ROUNDED EDGE, THEN A SAW CUT SHALL BE USED TO MANUFACTURE A PERPENDICULAR EDGE AS SHOWN IN THE DETAIL. THE ENGINEER SHALL BE THE SOLE JUDGE CONCERNING THE USE OF THIS DETAIL

HMA DETAIL AT BUTT JOINTS

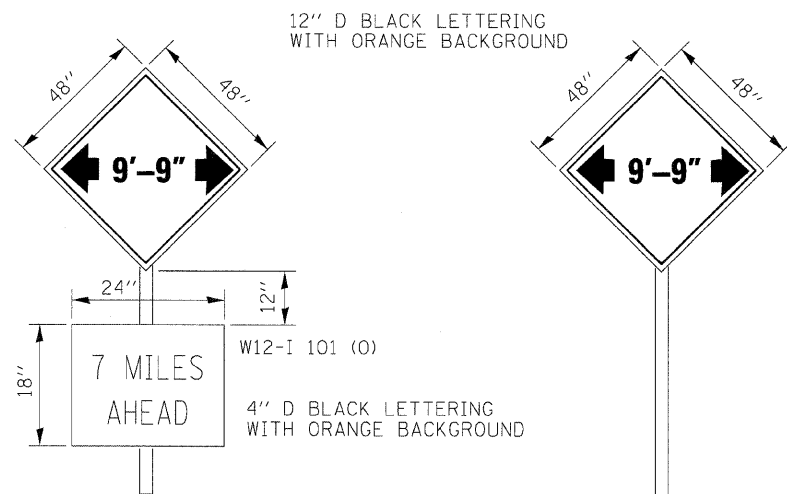

TO BE POST MOUNTED AS SHOWN ELSEWHERE IN THE PLANS.

THE ENGINEER WILL NOTIFY DISTRICT 3 BUREAU OF OPERATIONS 14 CALENDAR DAYS PRIOR TO INSTALLING ANY TRAFFIC CONTROL DEVICES THAT WILL RESTRICT THE PAVEMENT WIDTH.

THE CONTRACTOR SHALL BE RESPONSIBLE FOR COORDINATING WITH THE ENGINEER TO MEET THIS REQUIREMENT.

COST OF SUPPLYING, INSTALLING, MAINTAINING AND REMOVING WIDTH RESTRICTION SIGNS SHALL BE INCLUDED IN THE COST OF THE TRAFFIC CONTROL AND PROTECTION PAY ITEMS.

WIDTH RESTRICTION SIGNING DETAILS

SEE STAGE CONSTRUCTION PLANS FOR THE LOCATION OF THE PROPOSED SIGNS

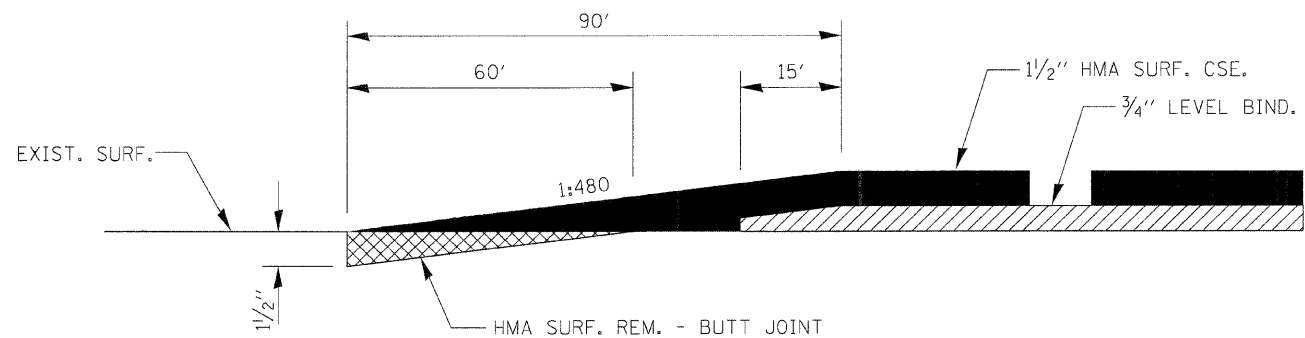

BUTT JOINT DETAIL

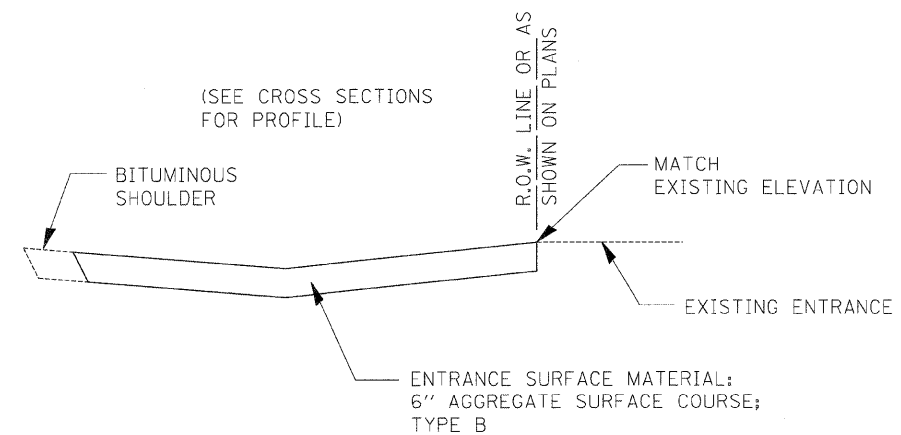
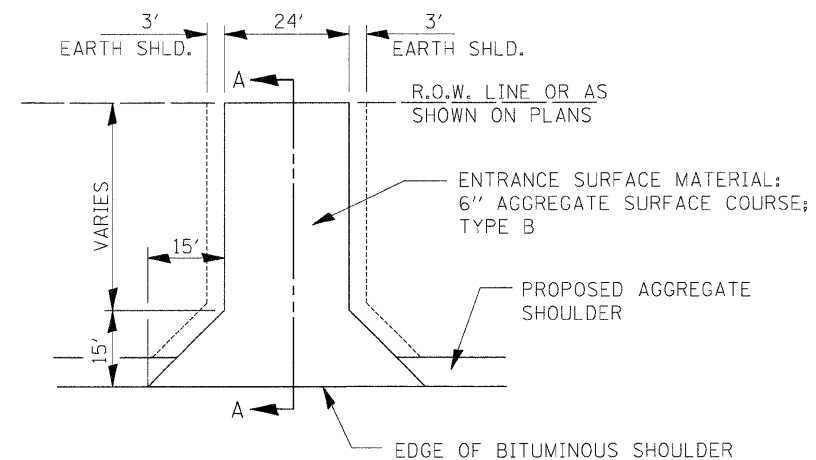

FIELD ENTRANCE DETAIL

FILE NAME =	USER NAME = SAW	DESIGNED - RAC	REVISED -
...:\Civi\10366741-SHT-Details.dgn		DRAWN - SAW	REVISED -
	PLOT SCALE = 20.0000' / IN.	CHECKED - RAC	REVISED -
	PLOT DATE = 7/14/2009	DATE - 07/17/09	REVISED -

STATE OF ILLINOIS
 DEPARTMENT OF TRANSPORTATION

ILLINOIS ROUTE 71
 DETAILS

SCALE: SHEET NO. OF SHEETS STA. 638+50 TO STA. 756+50

F.A.P. RTE.	SECTION	COUNTY	TOTAL SHEETS	SHEET NO.
311	(3)BR- 1, 2, & (4)BR	LASALLE	66	51
FED. ROAD DIST. NO. ILLINOIS FED. AID PROJECT			CONTRACT NO. 66741	