

F.A.I. RTE.	SECTION	COUNTY	TOTAL SHEETS	SHEET NO.
80	**	BUREAU	344	1
		ILLINOIS	CONTRACT NO. 66908	

D-93-026-09

\*\*06-[7BR&BR-1,7VB-M,6BR&6,7 RS-1 & I]

P-93-019-05

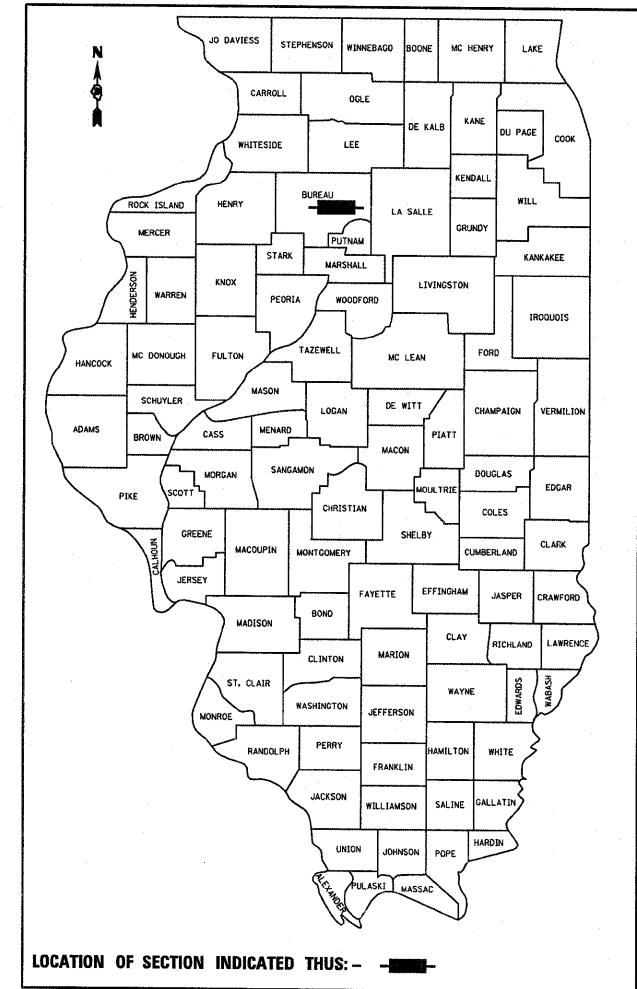

LOCATION OF SECTION INDICATED THUS: - ■ -

FUNCTIONAL CLASSIFICATION-INTERSTATE

ADT (2008) = 22,200  
 % PV = 60.4% MU = 35.1% SU = 4.5

STATE OF ILLINOIS  
 DEPARTMENT OF TRANSPORTATION  
 DIVISION OF HIGHWAYS

SUBMITTED Sept 8 2009  
George Ryan  
 DEPUTY DIRECTOR OF HIGHWAYS, REGION ENGINEER

October 2, 2009  
Charles J. Ingerson  
 ENGINEER OF DESIGN AND ENVIRONMENT

October 2, 2009  
Christine M. Reed  
 DIRECTOR OF HIGHWAYS, CHIEF ENGINEER

PRINTED BY THE AUTHORITY  
 OF THE STATE OF ILLINOIS

STATE OF ILLINOIS  
 DEPARTMENT OF TRANSPORTATION  
 DIVISION OF HIGHWAYS

PROPOSED  
 HIGHWAY PLANS

FAI ROUTE 80 (I-80)

SECTION 06-[7BR&BR-1,7VB-M,6BR&6,7 ETC]

PROJECT ACBRF-ACNHI-080-2(065)062

BUREAU COUNTY

TYPE of IMPROVEMENT-  
 RESURF, PATCHING, 6 BR REPL  
 & MINOR BRIDGE REPAIRS

C-93-049-09

INDEX OF SHEETS

- 1 COVERSHEET
- 2 GENERAL NOTES
- 3-7 SUMMARY OF QUANTITIES
- 8-14 TYPICAL SECTION
- 15-26 SCHEDULE OF QUANTITIES
- 27-29 ALIGNMENT SHEETS
- 30 LOCATION MAP
- 31-44 PLAN SHEETS
- 45-48 PLAN & PROFILE SHEETS NEAR PROP SN 006-0172/-0173
- 49-52 PLAN & PROFILE SHEETS NEAR PROP SN 006-0170/-0171
- 53-56 PLAN & PROFILE SHEETS NEAR PROP SN 006-0174/-0175
- 57 STAGE I TYPICAL SECTION
- 58-73 STAGE I CONSTRUCTION PLAN SHEETS
- 74 STAGE II TYPICAL SECTION
- 75-90 STAGE II CONSTRUCTION PLAN SHEETS
- 91 RIGHT-OF-WAY SHEET
- 92 ALTERNATE ROUTE SIGNING
- 93-94 TEMPORARY LIGHTING DETAIL
- 95-153 BRIDGE PLANS SN 006-0170 & 006-0171
- 154-198 BRIDGE PLANS SN 006-0172 & 006-0173
- 199-237 BRIDGE PLANS SN 006-0174 & 006-0175
- 238-241 BRIDGE PLANS SN 006-0127
- 242-245 BRIDGE PLANS SN 006-0129
- 246-249 BRIDGE PLANS SN 006-0133
- 250-288 EXISTING BRIDGE PLANS
- 289-294 DETAILS
- 295-344 CROSS SECTIONS

STANDARDS

- BLR 22-6 TYPICAL APP OF T.C.D. RURAL LOCAL HIGHWAY (2-LANE 2-WAY RURAL TRAF.) (ROAD CLOSED TO THRU TRAFFIC)
- 000001-05 STANDARD SYMBOLS, ABBREVIATIONS AND PATTERNS
- 001001-02 AREAS OF REINFORCEMENT BARS
- 001006 DECIMAL OF AN INCH AND OF A FOOT
- 280001-04 TEMPORARY EROSION CONTROL SYSTEMS
- 420001-07 PAVEMENT JOINTS
- 420401-07 BRIDGE APPROACH PAVEMENT CONNECTOR
- 421001-02 BAR REINFORCEMENT FOR CRC PAVEMENT
- 421101-07 24' (7.2 m) CRC PAVEMENT (WITH WIDE FLANGE BEAM TERMINAL JOINT)
- 442101-07 CLASS B PATCHES
- 482001-02 HMA SHOULDER ADJACENT TO FLEXIBLE PAVEMENT
- 483001-04 PCC SHOULDER
- 515001-03 NAME PLATE FOR BRIDGES
- 542401-01 METAL END SECTION FOR PIPE CULVERTS
- 609006-04 BRIDGE APPROACH PAVEMENT (DRAIN DETAIL)
- 630001-08 STEEL PLATE BEAM GUARDRAIL
- 630201-06 PCC/HMA STABILIZATION AT STEEL PLATE BEAM GUARDRAIL
- 630301-05 SHOULDER WIDENING FOR TYPE 1 (SPECIAL) GUARDRAIL TERMINALS
- 631011-05 TRAFFIC BARRIER TERMINAL, TYPE 2
- 631031-07 TRAFFIC BARRIER TERMINAL, TYPE 6
- 635001-01 DELINEATORS
- 635006-03 REFLECTOR AND TERMINAL MARKER PLACEMENT
- 635011-02 REFLECTOR MARKER AND MOUNTING DETAILS
- 638001-02 GLARE SCREEN BLADES
- 642001-01 SHOULDER RUMBLE STRIPS
- 665001-02 WOVEN WIRE FENCE
- 701401-05 LANE CLOSURE, FREEWAY/EXPRESSWAY
- 701402-07 LANE CLOSURE, FREEWAY/EXPRESSWAY, WITH BARRIER
- 701406-05 LANE CLOSURE, FREEWAY/EXPRESSWAY, DAY OPERATIONS ONLY
- 701411-05 LANE CLOSURE, MULTILANE, AT ENTRANCE OR EXIT RAMP FOR SPEEDS \*\*e\*\* 45 MPH
- 701901-01 TRAFFIC CONTROL DEVICES
- 704001-05 TEMPORARY CONCRETE BARRIER
- 780001-02 TYPICAL PAVEMENT MARKINGS
- 781001-03 TYPICAL APPLICATIONS RAISED REFLECTIVE PAVEMENT MARKERS

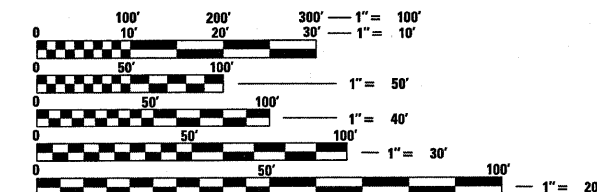

FULL SIZE PLANS HAVE BEEN PREPARED USING STANDARD ENGINEERING SCALES. REDUCED SIZED PLANS WILL NOT CONFORM TO STANDARD SCALES. IN MAKING MEASUREMENTS ON REDUCED PLANS, THE ABOVE SCALES MAY BE USED.

J.U.L.I.E.  
 JOINT UTILITY LOCATION INFORMATION FOR EXCAVATION  
 1-800-892-0123  
 OR 811

PROJECT ENGINEER JOE KANNEL  
 UNIT CHIEF PAT BRABOY

CONTRACT NO. 66908

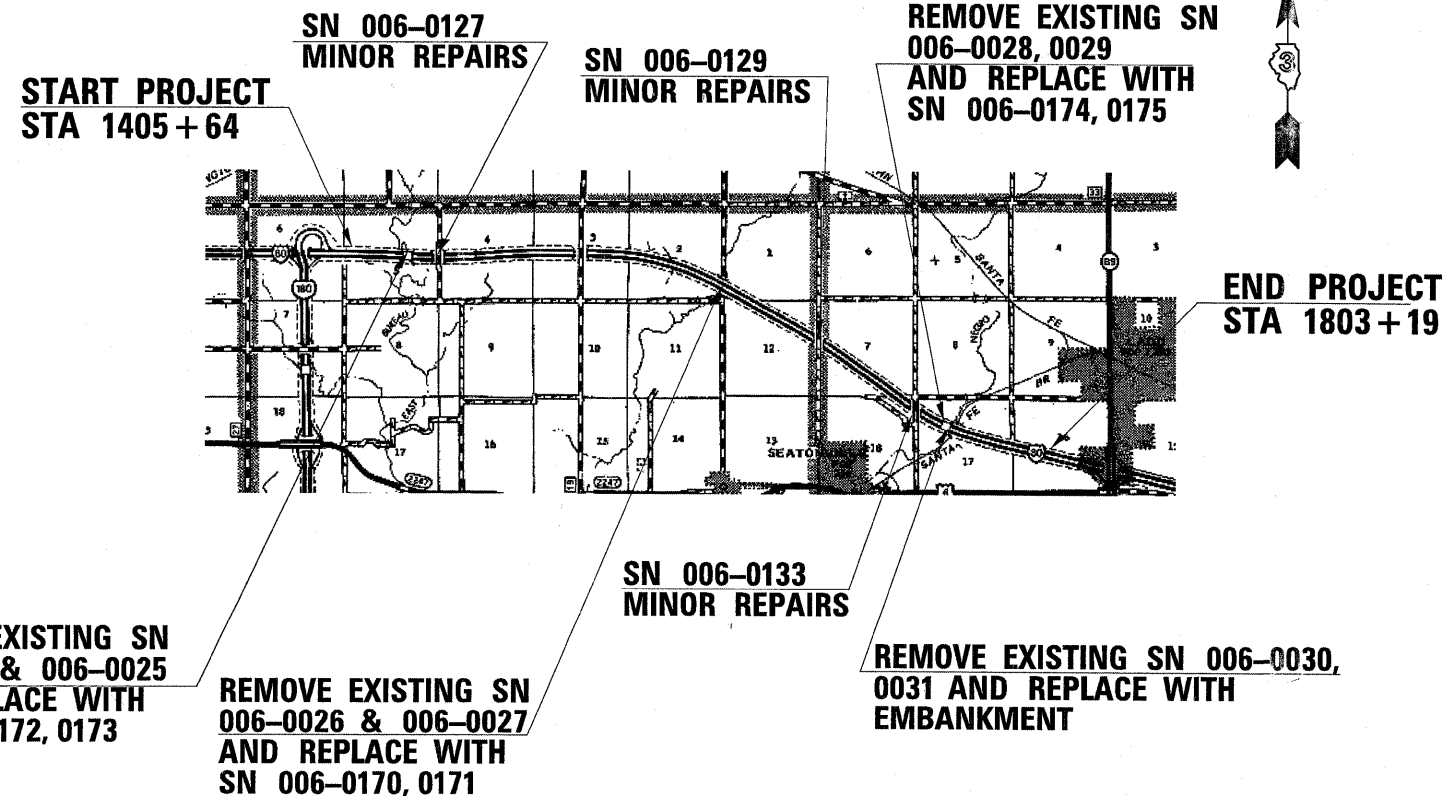

GROSS LENGTH = 38,661 FT. = 7.36 MILE

NET LENGTH = 38,661 FT. = 7.36 MILE

**GENERAL NOTES**  
(Revised May 13, 2009)

THE THICKNESS OF HMA SHOWN ON THE PLANS IS THE NOMINAL THICKNESS. DEVIATIONS FROM THE NOMINAL THICKNESS WILL BE PERMITTED WHEN SUCH DEVIATIONS OCCUR DUE TO IRREGULARITIES IN THE EXISTING SURFACE OR BASE ON WHICH THE HMA IS PLACED.

EXCEPT AS NOTED ON THE PLANS, PAVEMENT GRADES SHOWN ARE AT THE TOP OF PAVEMENT SURFACES.

BEFORE ORDERING PIPE CULVERTS OR PIPE DRAINS, THE CONTRACTOR SHALL CONSULT THE ENGINEER FOR EXACT LENGTHS.

THE ENGINEER WILL BE THE SOLE JUDGE CONCERNING CURING TIME FOR THE VARIOUS HMA LIFTS.

FOR STABILIZATION, ALL TYPE III BARRICADES SHALL REQUIRE A MINIMUM OF FOUR SAND BAGS PER BARRICADE.

SEEDING SHALL NOT BE PERMITTED AT ANY TIME WHEN THE GROUND IS FROZEN, WET, OR IN AN UNTILLABLE CONDITION. LOCATIONS TO BE SEEDED WILL BE DETERMINED BY THE ENGINEER.

ONLY THOSE TREES DESIGNATED BY THE ENGINEER OR LISTED IN THE TREE REMOVAL SCHEDULE SHALL BE REMOVED. THE CONTRACTOR SHALL PROTECT ALL REMAINING TREES FROM DAMAGE DUE TO HIS OPERATIONS.

THE FINISHED EARTHWORK SHALL HAVE A VEGETATION SUSTAINING SOIL COVERING THE TOP FOUR INCHES IN AREAS TO BE SEEDED OR SODDED. THE VEGETATION SUSTAINING SOIL REQUIRED WILL NOT BE PAID FOR SEPARATELY BUT SHALL BE INCLUDED IN THE COST OF FURNISHED EXCAVATION.

ON EXISTING PAVEMENT WHICH MAY BE SUPERELEVATED, THE NEW HMA PAVEMENT SHALL BE BUILT WITH THE SAME SUPERELEVATION UNLESS NEW SUPERELEVATION RATES ARE GIVEN ON THE PLANS.

ALL ELEVATIONS REFERRING TO U.S.G.S. MEAN SEA LEVEL DATUM.

ABANDONED UNDERGROUND UTILITIES THAT CONFLICT WITH CONSTRUCTION SHALL BE DISPOSED OF OUTSIDE THE LIMITS OF THE RIGHT OF WAY ACCORDING TO ARTICLE 202.03 OF THE STANDARD SPECIFICATIONS AND AS DIRECTED BY THE ENGINEER. THIS WORK WILL NOT BE PAID FOR SEPARATELY, BUT SHALL BE INCLUDED IN THE COST OF EARTH EXCAVATION.

ANY REFERENCE TO A STANDARD IN THESE PLANS SHALL BE INTERPRETED TO MEAN THE EDITION AS INDICATED BY THE SUBNUMBER SHOWN IN THE LIST OF STANDARDS OR THE COPY INCLUDED IN THESE PLANS.

THE FOLLOWING RATES OF APPLICATION HAVE BEEN USED IN CALCULATING PLAN QUANTITIES:

GRANULAR MATERIALS	2.05	TONS / CU YD
BIT MATERIALS (PRIME COAT) ON AGGREGATE BASES	0.375	GAL / SQ YD
POLYMERIZED BIT MATERIALS (PRIME COAT)	0.10	GAL / SQ YD
FOR ADDITIONAL HMA LIFTS "FOG COAT"	0.08	GAL / SQ YD
HMA RESURFACING	112	LBS / SQ YD / IN
SHORT TERM PAVEMENT MARKING	10	FT /100 FT OF APPLICATION
MIX FOR CRACKS, JTS & FLGWYS	0.0003	TONS / SQ YD
LEVEL BINDER (HAND METHOD)	0.0005	TONS / SQ YD
TEMPORARY DITCH CHECKS	5	TONS AGGREGATE

ALL DAMAGE TO DEPARTMENT OWNED UNDERGROUND FACILITIES, CAUSED BY THE CONTRACTOR SHALL BE REPAIRED TO THE SATISFACTION OF THE DEPARTMENT AT THE CONTRACTOR'S EXPENSE. THIS SHALL INCLUDE ALL TEMPORARY REPAIRS REQUIRED TO KEEP THE FACILITY OPERATIONAL WHILE MATERIAL IS BEING OBTAINED TO MAKE PERMANENT REPAIRS. SPlicing OF ELECTRIC CABLE SHALL NOT BE ALLOWED. ELECTRIC CABLE SHALL BE REPLACED FROM POLE TO POLE OR CONTROLLER.

THE WORK REQUIRED TO CONNECT ANY SEWER TO AN EXISTING DRAINAGE STRUCTURE OR PIPE WILL NOT BE PAID FOR SEPARATELY, BUT SHALL BE CONSIDERED AS INCLUDED IN THE CONTRACT UNIT PRICE BID FOR THE SEWER ITEMS.

THE CONTRACTOR SHALL CONTACT JULIE AT LEAST 48 HOURS PRIOR TO EXCAVATION TO DETERMINE WHICH UTILITIES ARE IN THE AREA.

WHEREVER IN THESE PLANS REFERENCE IS MADE TO SECTION 06-[7BR&BR-1,7VB-M,6BR&6,7RS-1&I] IT SHALL REFER TO SECTION 06-[7BR&BR-1,7VB-M,6BR&6,7ET]

MAINLINE	HMA Surface	HMA Level Binder	Stabilized Subbase - HMA 4"
PG Grade	SBS PG70-22	SBS PG70-22	PG58-22
Design Air Voids	4.0% @ N105	4.0% @ N105	2.0% @ N30
Mixture Composition	IL 9.5 or IL 12.5	IL 9.5	All Other
Friction Aggregate	Mixture D		
Density Test Method	Correlation	Satisfaction of Engineer	Cores

Full-Depth HMA	HMA Surface (1 3/4")	HMA Binder		
		Top 2 3/4"	Middle 12 3/4"	Bottom 4"
PG Grade	SBS PG70-22	SBS PG70-22	SBS PG70-22	PG64-22
Design Air Voids	4.0% @ N105	4.0% @ N105	4.0% @ N90	4.0% @ N70
Mixture Composition	IL 9.5 or IL 12.5	IL 19.0	IL 19.0	IL 19.0
Friction Aggregate	Mixture D			
Density Test Method	Cores	Cores	Cores	Cores

HMA Shoulders (Without Staged Traffic)	HMA Surface (Top 1 3/4")	HMA Binder
PG Grade	PG64-22	PG64-22
Design Air Voids	4.0% @ N50	4.0% @ N50
Mixture Composition	IL 9.5 or IL 12.5	IL 19.0
Friction Aggregate	Mixture C	
Density Test Method	Correlation	Cores

HMA Shoulders (With Staged Traffic)	HMA Surface (Top 1 3/4")	HMA Binder
PG Grade	SBS PG70-22	SBS PG70-22
Design Air Voids	4.0% @ N105	4.0% @ N90
Mixture Composition	IL 9.5 or IL 12.5	IL 19.0
Friction Aggregate	Mixture D	
Density Test Method	Correlation	Cores

**COMMITMENTS:**

- STRUCTURAL STATUS AND VERTICAL CLEARANCE FORMS
- 404 PERMIT
- THE RESIDENT ENGINEER IS TO NOTIFY LOCAL OFFICIALS TWO WEEKS PRIOR TO CLOSING OF OVERHEAD STRUCTURES-SEE COMMITMENT FILE FOR PHONE NUMBERS.
- STORM WATER POLLUTION PREVENTION PLAN

**NOTE ON STATIONING:**  
THE ALIGNMENT AND TIE SHEETS SHOW THE OLD STATIONING ALONG I-80. ALL THE BRIDGE PLANS AND THE ROADWAY WORK NEAR THE BRIDGE PLANS WERE DEVELOPED USING THIS OLD STATIONING, WHILE THE REST OF THE ROADWAY IS USING CURRENT STATIONING. THE THREE AREAS OF INTEREST ON THIS PROJECT WHICH USED THE OLD STATIONING AND THEIR CORRESPONDING NEW STATIONING ARE AS FOLLOWS:

STA 1429+35.20 TO STA 1442+10.20(NEW)/STA 3279+75 TO STA 3292+50(OLD)  
STA 1603+61.79 TO STA 1620+36.79(NEW)/STA 3454+00 TO STA 3470+75(OLD)  
STA 1752+63.97 TO STA 1768+63.97(NEW)/STA 3603+00 TO STA 3619+00(OLD)

SEE PLANS SHEETS FOR CLARITY

STATE OF ILLINOIS  
DEPARTMENT OF TRANSPORTATION  
DISTRICT THREE

PREPARED BY: [Signature]  
DISTRICT STUDIES & PLANS ENGINEER

DATE: 9/8/09

EXAMINED BY: [Signature]  
DISTRICT CONSTRUCTION ENGINEER

[Signature]  
DISTRICT MATERIALS ENGINEER

[Signature]  
DISTRICT OPERATIONS ENGINEER

REVISIONS	
NAME	DATE

ILLINOIS DEPARTMENT OF TRANSPORTATION

# GENERAL NOTES

**\*\*06-[7BR&BR-1,7VB-M,6BR&6,7RS-1 & I]**

F.A. RTE. I-80	SECTION **	COUNTY BUREAU	TOTAL SHEETS 344	SHEET NO. 2
SCALE: _____			CONTRACT NO. 66908	
SHEET NO. ___ OF ___ SHEETS			STA. _____ TO STA. _____	
ILLINOIS FED. AID PROJECT				

FILE NAME =	USER NAME = braboypc	DESIGNED - ___	REVISED - ___
c:\pwwork\pindot\braboypc\d0112648\d368908-shr-deta1.s.DGN		DRAWN - ___	REVISED - ___
	PLOT SCALE = 50.7353' / IN.	CHECKED - ___	REVISED - ___
	PLOT DATE = Sep 07, 2009 - 02:17:55 PM	DATE - ___	REVISED - ___

STATE OF ILLINOIS  
DEPARTMENT OF TRANSPORTATION

GENERAL NOTES

**SUMMARY OF QUANTITIES**

CODE NO	ITEM	UNIT	TOTAL QTY 80% FED. 20% STATE	ACNHI						
				RDWY I000-2A	ACBRF			ACNHI		
					006-0170 006-0171	006-0172 006-0173	006-0174 006-0175	006-0133	006-0127	006-0129
				X581-5B	X081-2A	X081-2A	SFTY-2A	SFTY-2A	SFTY-2A	
20100110	TREE REMOVAL (6 TO 15 UNITS DIAMETER)	UNIT	1944	1944						
20100210	TREE REMOVAL (OVER 15 UNITS DIAMETER)	UNIT	160	160						
* 20101400	NITROGEN FERTILIZER NUTRIENT	POUND	648	648						
* 20101500	PHOSPHORUS FERTILIZER NUTRIENT	POUND	648	648						
* 20101600	POTASSIUM FERTILIZER NUTRIENT	POUND	648	648						
20200100	EARTH EXCAVATION	CU YD	1242	1242						
20201200	REMOVAL AND DISPOSAL OF UNSUITABLE MATERIAL	CU YD	7675	7675						
20400800	FURNISHED EXCAVATION	CU YD	66490	66490						
20700400	POROUS GRANULAR EMBANKMENT, SPECIAL	CU YD	1218		336	292	590			
* 25000300	SEEDING, CLASS 3	ACRE	9.75	9.75						
* 25100635	HEAVY DUTY EROSION CONTROL BLANKET	SO YD	40341	40341						
28000250	TEMPORARY EROSION CONTROL SEEDING	POUND	720	720						
28000300	TEMPORARY DITCH CHECKS	EACH	32	32						
28000400	PERIMETER EROSION BARRIER	FOOT	18144	18144						
28100107	STONE RIPRAP, CLASS A4	SO YD	8383		1271	3222	3890			
28100109	STONE RIPRAP, CLASS A5	SO YD	2528				2528			
28200200	FILTER FABRIC	SO YD	11177		1271	3222	6684			
31102100	SUB-BASE GRANULAR MATERIAL, TYPE C 4"	SO YD	2610	2610						
31200500	STABILIZED SUBBASE - HOT-MIX ASPHALT, 4"	SO YD	3480	3480						
35100500	AGGREGATE BASE COURSE, TYPE A 6"	SO YD	3572	3572						
35101100	AGGREGATE BASE COURSE, TYPE A 12"	SO YD	1809	1809						
<del>4020800</del>	AGGREGATE SURFACE COURSE, TYPE B 12"	SO YD	1200	1200						
40600115	POLYMERIZED BITUMINOUS MATERIALS (PRIME COAT)	GALLON	31493	31493						
40600400	MIXTURE FOR CRACKS, JOINTS, AND FLANGEWAYS	TON	57	57						
40600300	AGGREGATE (PRIME COAT)	TON	418	418						
40600555	LEVELING BINDER (HAND METHOD), N105	TON	94	94						
40600845	POLYMERIZED LEVELING BINDER (MACHINE METHOD), N90	TON	1050	1050						
40600895	CONSTRUCTING TEST STRIP	EACH	1	1						
40600982	HOT-MIX ASPHALT SURFACE REMOVAL - BUTT JOINT	SO YD	1068	1068						
40600985	PORTLAND CEMENT CONCRETE SURFACE REMOVAL - BUTT JOINT	SO YD	2520	2520						
40603085	HOT-MIX ASPHALT BINDER COURSE, IL-19.0, N70	TON	405	405						
40603240	POLYMERIZED HOT-MIX ASPHALT BINDER COURSE, IL-19.0, N90	TON	1291	1291						
40603245	POLYMERIZED HOT-MIX ASPHALT BINDER COURSE, IL-19.0, N105	TON	279	279						

\* SPECIALTY ITEMS

\*\*06-[7BR&BR-1,7VB-M,6BR&6,7 RS-1 & I]

FILE NAME =	USER NAME = braboypc	DESIGNED -	REVISED -	<b>STATE OF ILLINOIS DEPARTMENT OF TRANSPORTATION</b>	<b>SUMMARY OF QUANTITIES</b>	F.A. RTE. I-80	SECTION **	COUNTY BUREAU	TOTAL SHEETS 344	SHEET NO. 3		
ct\pw_work\VPWIDOT\BRABOYPC\d0112640\d36	908-shd-details.DGN	DRAWN -	REVISED -			SCALE: _____	SHEET NO. ___ OF ___ SHEETS	STA. _____ TO STA. _____	CONTRACT NO. 66908			
	PLOT SCALE = 50.0000' / IN.	CHECKED -	REVISED -			ILLINOIS FED. AID PROJECT						
	PLOT DATE = Sep 08, 2009 - 08:16:11 AM	DATE -	REVISED -									

SUMMARY OF QUANTITIES

CODE NO	ITEM	UNIT	TOTAL QTY 80% FED. 20% STATE	ACNHI RDWY 1000-2A	ACBRF			ACNHI		
					006-0170 006-0171 X581-5B	006-0172 006-0173 X081-2A	006-0174 006-0175 X081-2A	006-0133 SFTY-2A	006-0127 SFTY-2A	006-0129 SFTY-2A
40603310	HOT-MIX ASPHALT SURFACE COURSE, MIX "C", N50	TON	8143	8143						
40603550	POLYMERIZED HOT-MIX ASPHALT SURFACE COURSE, MIX "D", N105	TON	23876	23876						
42001200	PAVEMENT FABRIC	SQ YD	54	54						
42100300	CONTINUOUSLY REINFORCED PORTLAND CEMENT CONCRETE PAVEMENT 10"	SQ YD	3480	3480						
42100900	PAVEMENT REINFORCEMENT 10"	SQ YD	3480	3480						
42101020	WIDE FLANGE BEAM TERMINAL JOINT COMPLETE 24'	EACH	2	2						
44000100	PAVEMENT REMOVAL	SQ YD	5477	5477						
44000198	HOT-MIX ASPHALT SURFACE REMOVAL, VARIABLE DEPTH	SQ YD	10668	10668						
44001114	HOT-MIX ASPHALT SURFACE REMOVAL (ASBESTOS)	SQ YD	4920		2116	1238	1566			
44000182	HOT-MIX ASPHALT SURFACE REMOVAL, 8"	SQ YD	32455	32455						
44213200	SAW CUTS	FOOT	996	996						
44004250	PAVED SHOULDER REMOVAL	SQ YD	1841	1841						
44201055	CLASS B PATCHES, TYPE II, 17 INCH	SQ YD	183	183						
44201057	CLASS B PATCHES, TYPE III, 17 INCH	SQ YD	48	48						
44201053	CLASS B PATCHES, TYPE IV, 17 INCH	SQ YD	54	54						
48101200	AGGREGATE SHOULDERS, TYPE B	TON	5429	5429						
48203021	HOT-MIX ASPHALT SHOULDERS, 6"	SQ YD	3782	3782						
48203029	HOT-MIX ASPHALT SHOULDERS, 8"	SQ YD	32455	32455						
48203045	HOT-MIX ASPHALT SHOULDERS, 12"	SQ YD	3213	3213						
48300500	PORTLAND CEMENT CONCRETE SHOULDERS 10"	SQ YD	2320	2320						
50100100	REMOVAL OF EXISTING STRUCTURES	EACH	8	2	2	2	2			
50157300	PROTECTIVE SHIELD	SQ YD	834		354				160	320
50200100	STRUCTURE EXCAVATION	CU YD	2497		975	500	1022			
50300100	FLOOR DRAINS	EACH	102		68	34				
50300225	CONCRETE STRUCTURES	CU YD	1969		834	513	622			
50300255	CONCRETE SUPERSTRUCTURE	CU YD	3209		1285	846	1078			
50300260	BRIDGE DECK GROOVING	SQ YD	6695		3324	1463	1908			
50300280	CONCRETE ENCASEMENT	CU YD	61		16	25	20			
50300300	PROTECTIVE COAT	SQ YD	8404		4199	1829	2376			
50300530	FLOOR DRAIN EXTENSION	EACH	14					12		2
50400745	FURNISHING AND ERECTING PRECAST PRESTRESSED CONCRETE BULB T-BEAMS 72"	FOOT	2608				2608			
50400805	FURNISHING AND ERECTING PRECAST PRESTRESSED CONCRETE I-BEAMS, 36 IN.	FOOT	2358			2358				
50400905	FURNISHING AND ERECTING PRECAST PRESTRESSED CONCRETE I-BEAMS, 42 IN.	FOOT	4599		4599					
50800205	REINFORCEMENT BARS, EPOXY COATED	POUND	863780		340800	215950	307030			

\* SPECIALTY ITEMS

FILE NAME =	USER NAME = braboygo	DESIGNED -	REVISED -	<b>STATE OF ILLINOIS DEPARTMENT OF TRANSPORTATION</b>	<b>SUMMARY OF QUANTITIES</b>	F.A. RTE. I-80	SECTION **	COUNTY BUREAU	TOTAL SHEETS 344	SHEET NO. 4	
01\pwwork\pwwork\braboygo\d0112648\d368	908-sh-t-detail.dgn	DRAWN -	REVISED -			SCALE: _____	SHEET NO. _____ OF _____ SHEETS	STA. _____ TO STA. _____	CONTRACT NO. 66908		ILLINOIS FED. AID PROJECT
	PLOT SCALE = 50.7953' / IN.	CHECKED -	REVISED -								
	PLOT DATE = Sep 07, 2009 - 02:17:27 PM	DATE -	REVISED -								

\*\*06-[7BR&BR-1,7VB-M,6BR&6,7 RS-1 & I]

**SUMMARY OF QUANTITIES**

CODE NO	ITEM	UNIT	TOTAL QTY	ACNHI						
				80% FED. 20% STATE RDWY 1000ZA	ACBRF			ACNHI		
					006-0170 006-0171 X581-5B	006-0172 006-0173 X081-2A	006-0174 006-0175 X081-2A	006-0133 SFTY-2A	006-0127 SFTY-2A	006-0129 SFTY-2A
50800515	BAR SPLICERS	EACH	504		176	160	168			
51100100	SLOPE WALL 4 INCH	SQ YD	920		920					
51201600	FURNISHING STEEL PILES HP12X53	FOOT	4486			4486				
51201800	FURNISHING STEEL PILES HP14X73	FOOT	13393		6807		6586			
51202305	DRIVING PILES	FOOT	17879		6807	4486	6586			
51203600	TEST PILE STEEL HP12X53	EACH	8			8				
51203800	TEST PILE STEEL HP14X73	EACH	20		12		8			
51205200	TEMPORARY SHEET PILING	SQ FT	523		523					
51500100	NAME PLATES	EACH	6		2	2	2			
52100010	ELASTOMERIC BEARING ASSEMBLY, TYPE I	EACH	56		56					
52100020	ELASTOMERIC BEARING ASSEMBLY, TYPE II	EACH	28		28					
52100530	ANCHOR BOLTS, 1 1/4"	EACH	168		168					
52100540	ANCHOR BOLTS, 1 1/2"	EACH	16				16			
54215547	METAL END SECTIONS 12"	EACH	8	8						
58700300	CONCRETE SEALER	SQ FT	820		820					
59100100	GEOCOMPOSITE WALL DRAIN	SQ YD	549		176	189	184			
59300100	CONTROLLED LOW-STRENGTH MATERIAL	CU YD	2.5						1	1.5
60100945	PIPE DRAINS 12"	FOOT	349	349						
60109580	PIPE UNDERDRAINS FOR STRUCTURES 4"	FOOT	859		270	333	256			
60900515	CONCRETE THRUST BLOCKS	EACH	8	8						
61000115	TYPE E INLET BOX, STANDARD 610001	EACH	8	8						
* 63000001	STEEL PLATE BEAM GUARD RAIL, TYPE A, 6 FOOT POSTS	FOOT	7880	7880						
* 63100045	TRAFFIC BARRIER TERMINAL, TYPE 2	EACH	12	12						
* 63100085	TRAFFIC BARRIER TERMINAL, TYPE 6	EACH	24	24						
* 63100167	TRAFFIC BARRIER TERMINAL, TYPE 1 (SPECIAL) TANGENT	EACH	6	6						
* 63100169	TRAFFIC BARRIER TERMINAL, TYPE 1 (SPECIAL) FLARED	EACH	12	12						
63200310	GUARDRAIL REMOVAL	FOOT	10341	10341						
63500105	DELINEATORS	EACH	236	236						
63500120	DELINEATOR REMOVAL	EACH	236	236						
63801205	TEMPORARY MODULAR GLARE SCREEN	FOOT	39565	39565						

\* SPECIALTY ITEMS

FILE NAME =	USER NAME = braboygo	DESIGNED -	REVISED -	<b>STATE OF ILLINOIS DEPARTMENT OF TRANSPORTATION</b>	<b>SUMMARY OF QUANTITIES</b>	F.A. RTE.	SECTION	COUNTY	TOTAL SHEETS	SHEET NO.
c:\pwork\pwork\braboygo\d0112648\d368908-shd-details.DGN	DRAWN -	REVISED -	I-80			**	BUREAU	344	5	
PLOT SCALE = 50.7353' / IN.	CHECKED -	REVISED -	SCALE: _____ SHEET NO. ___ OF ___ SHEETS STA. _____ TO STA. _____			CONTRACT NO. 66908				
PLOT DATE = Sep 07, 2009 - 02:17:18 PM	DATE -	REVISED -				ILLINOIS FED. AID PROJECT				

\*\*06-[7BR&BR-1,7VB-M,6BR&6,7 RS-1 & I]

SUMMARY OF QUANTITIES

CODE NO	ITEM	UNIT	TOTAL QTY 80% FED. 20% STATE	ACNHI RDWY I000-2A	ACBRF			ACNHI		
					006-0170 006-0171 X581-5B	006-0172 006-0173 X081-2A	006-0174 006-0175 X081-2A	006-0133 SFTY-2A	006-0127 SFTY-2A	006-0129 SFTY-2A
64200105	SHOULDER RUMBLE STRIP	FOOT	155195	155195						
66500105	WOVEN WIRE FENCE, 4'	FOOT	7875	7875						
66502300	WOVEN WIRE FENCE REMOVAL	FOOT	7875	7875						
67000400	ENGINEER'S FIELD OFFICE, TYPE A	CAL MO	20	20						
67100100	MOBILIZATION	L SUM	1	1						
70100420	TRAFFIC CONTROL AND PROTECTION, STANDARD 701411	EACH	1	1						
70101835	TRAFFIC CONTROL AND PROTECTION, STANDARD BLR 22	L SUM	1	1						
70103700	TRAFFIC CONTROL COMPLETE	L SUM	1	1						
70103815	TRAFFIC CONTROL SURVEILLANCE	CAL DA	200	200						
70106800	CHANGEABLE MESSAGE SIGN	CAL MO	30	30						
70300100	SHORT-TERM PAVEMENT MARKING	FOOT	7086	7086						
70300220	TEMPORARY PAVEMENT MARKING - LINE 4"	FOOT	152585	152585						
70300240	TEMPORARY PAVEMENT MARKING - LINE 6"	FOOT	19852	19852						
70301000	WORK ZONE PAVEMENT MARKING REMOVAL	SQ FT	98722	98722						
70400100	TEMPORARY CONCRETE BARRIER	FOOT	39565	39565						
70400200	RELOCATE TEMPORARY CONCRETE BARRIER	FOOT	39364	39364						
70500100	TEMPORARY STEEL PLATE BEAM GUARD RAIL, TYPE A	FOOT	1500	1500						
* 78000200	THERMOPLASTIC PAVEMENT MARKING - LINE 4"	FOOT	152585	152585						
* 78004230	PREFORMED PLASTIC PAVEMENT MARKING, TYPE B - INLAID - LINE 6"	FOOT	19073	19073						
* 78008210	POLYUREA PAVEMENT MARKING TYPE I - LINE 4"	FOOT	6235	6235						
* 78008230	POLYUREA PAVEMENT MARKING TYPE I - LINE 6"	FOOT	779	779						
* 78100100	RAISED REFLECTIVE PAVEMENT MARKER	EACH	1918	1918						
* 78100105	RAISED REFLECTIVE PAVEMENT MARKER (BRIDGE)	EACH	84	84						
* 78200405	GUARDRAIL MARKERS	EACH	89	89						
* 78200500	BARRIER WALL MARKERS	EACH	32	32						
* 78201000	TERMINAL MARKER - DIRECT APPLIED	EACH	12	12						
78300105	PAVEMENT MARKING REMOVAL	FOOT	87531	87531						
78300200	RAISED REFLECTIVE PAVEMENT MARKER REMOVAL	EACH	1918	1918						
X0321468	PLUG EXISTING DECK DRAINS	EACH	14						8	6
X0322729	MATERIAL TRANSFER DEVICE	TON	23876	23876						
X0323644	PAVEMENT MARKING GROOVING	FOOT	6896	6896						
* X0326208	ALTERNATE ROUTE SIGNING	L SUM	1	1						
X0326215	REMOVE TEMPOARY LIGHTING SYSTEM	L SUM	1	1						
X5020501	UNDERWATER STRUCTURE EXCAVATION PROTECTION - LOCATION 1	EACH	1			1				
X5020502	UNDERWATER STRUCTURE EXCAVATION PROTECTION - LOCATION 2	EACH	1			1				
X5020503	UNDERWATER STRUCTURE EXCAVATION PROTECTION - LOCATION 3	EACH	1			1				
X5020504	UNDERWATER STRUCTURE EXCAVATION PROTECTION - LOCATION 4	EACH	1			1				

\* SPECIALTY ITEMS

FILE NAME =	USER NAME = brabogpo	DESIGNED -	REVISED -	<b>STATE OF ILLINOIS DEPARTMENT OF TRANSPORTATION</b>	<b>SUMMARY OF QUANTITIES</b>	F.A. RTE. =	SECTION	COUNTY	TOTAL SHEETS	SHEET NO.	
o:\pw\work\p\dot\brabogpo\d0112640\d368	908-shr-detail.dgn	DRAWN -	REVISED -			I-80	**	BUREAU	344	6	
	PLOT SCALE = 50.7353' / 1" IN.	CHECKED -	REVISED -			SCALE: _____ SHEET NO. ____ OF ____ SHEETS STA. _____ TO STA. _____		CONTRACT NO. 66908			
	PLOT DATE = Sep 07, 2009 - 02:17:10 PM	DATE -	REVISED -			ILLINOIS FED. AID PROJECT					

\*\*06-[7BR&BR-1,7VB-M,6BR&6,7 RS-1 & I]

SUMMARY OF QUANTITIES

CODE NO	ITEM	UNIT	TOTAL QTY 80% FED 20% STATE	ACNHI RDWY I000-2A	ACBRF			ACNHI		
					006-0170 006-0171	006-0172 006-0173	006-0174 006-0175	006-0133	006-0127	006-0129
X7010805	TRAFFIC CONTROL AND PROTECTION, STANDARD, 701401 (SPECIAL)	LSUM	1	1	X581-5B	X081-2A	X081-2A	SFTY-2A	SFTY-2A	SFTY-2A
X7030100	WET TEMPORARY PAVEMENT MARKING TAPE, TYPE III	FOOT	329582	329582						
* X7200201	WIDTH RESTRICTION SIGNING	L SUM	1	1						
X8410102	TEMPORARY LIGHTING SYSTEM	L SUM	1	1						
X8410118	MAINTAINANCE OF TEMPORARY LIGHTING SYSTEM	L SUM	1	1						
Z0013798	CONSTRUCTION LAYOUT	L SUM	1	1						
Z0017100	DOWEL BARS	EACH	360	360						
Z0018800	DRAINAGE SYSTEM	L SUM	1			1				
Z0030150	IMPACT ATTENUATORS (NON-REDIRECTIVE), TEST LEVEL 3	EACH	20	20						
Z0075300	TIE BARS	EACH	40	40						
X0325305	STRUCTURAL REPAIR OF CONCRETE (DEPTH EQUAL TO OR LESS THAN 5 INCHES)	SQ FT	3						3	
X0325969	PORTABLE VEHICLE MOUNTED CHANGEABLE MESSAGE BOARD	CAL DA	200	200						
Z0001050	AGGREGATE SUBGRADE 12"	SQ YD	6089	6089						
Z0016200	DECK SLAB REPAIR (PARTIAL)	SQ YD	56.1					24	17.2	14.9
<del>X0223630</del>	<del>DRAINAGE SCUPPERS, DS11</del>	<del>EACH</del>	<del>17</del>			12	5			
† Z0076600	TRAINEES	Hour	4,000	4,000						

\* SPECIALTY ITEMS  
† Y080

FILE NAME =	USER NAME = braboygo	DESIGNED -	REVISED -	<b>STATE OF ILLINOIS DEPARTMENT OF TRANSPORTATION</b>	<b>SUMMARY OF QUANTITIES</b>	F.A. RTE.	SECTION	COUNTY	TOTAL SHEETS	SHEET NO.	
c:\pwork\pwork\braboygo\d0112640\d366	908-shd-details.DGN	DRAWN -	REVISED -			I-80	**	BUREAU	344	7	
	PLOT SCALE = 50.7353' / IN.	CHECKED -	REVISED -			SCALE: _____	SHEET NO. ___ OF ___ SHEETS	STA. _____ TO STA. _____	CONTRACT NO. 66908		
	PLOT DATE = Sep 07, 2009 - 02:17:03 PM	DATE -	REVISED -			ILLINOIS FED. AID PROJECT					

\*\*06-[7BR&BR-1,7VB-M,6BR&6,7 RS-1 & I]

# WEST OF IL 89 TO WEST OF IL 251

EXISTING  
TYPICAL SECTION

EXISTING  
TYPICAL SECTION

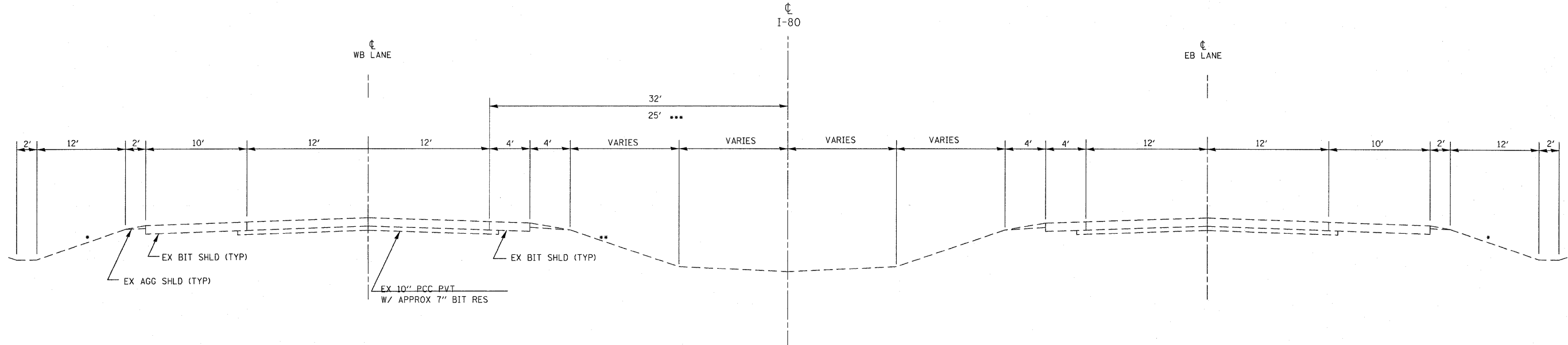

PROPOSED  
TYPICAL SECTION

PROPOSED  
TYPICAL SECTION

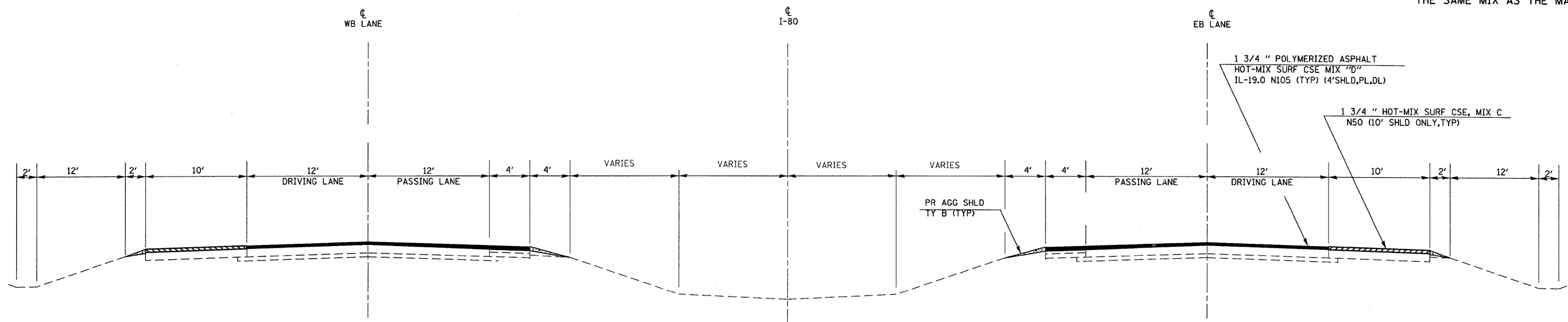

4' SHOULDERS WILL BE PAVED WITH THE SAME MIX AS THE MAINLINE.

**NOTE ON STATIONING:**  
THE ALIGNMENT AND TIE SHEETS SHOW THE OLD STATIONING ALONG I-80. ALL THE BRIDGE PLANS AND THE ROADWAY WORK NEAR THE BRIDGE PLANS WERE DEVELOPED USING THIS OLD STATIONING, WHILE THE REST OF THE ROADWAY IS USING CURRENT STATIONING. THE THREE AREAS OF INTEREST ON THIS PROJECT WHICH USED THE OLD STATIONING AND THEIR CORRESPONDING NEW STATIONING ARE AS FOLLOWS:

STA 1429+35.20 TO STA 1442+10.20(NEW)/STA 3279+75 TO STA 3292+50(OLD)  
STA 1603+61.79 TO STA 1620+36.79(NEW)/STA 3454+00 TO STA 3470+75(OLD)  
STA 1752+63.97 TO STA 1768+63.97(NEW)/STA 3603+00 TO STA 3619+00(OLD)

SEE PLANS SHEETS FOR CLARITY

**PROPOSED TYPICAL SECTION**

STA 1405+64 TO STA 1803+19\*  
STA EQS.:  
STA 1544+87.78(BK)=1544+88.38(AH)  
STA 1660+83.19(BK)=1660+82.35(AH)

**\*SEE OTHER TYPICAL SECTIONS FOR WORK NEAR STRUCTURES TO BE REMOVED/REPLACED BETWEEN THE FOLLOWING STATIONS:**

STA 1429+35.20 TO STA 1442+10.20  
STA 1603+61.79 TO STA 1620+36.79  
STA 1752+63.97 TO STA 1768+63.97  
(SEE NOTE ON STATIONING ON THE BOTTOM LEFT OF THIS PAGE)

\*\*06-[7BR&BR-1,7VB-M,6BR&6,7 RS-1 & 1

FILE NAME =	USER NAME = braboygo	DESIGNED -	REVISED -
et:\pwork\pwork\braboygo\d0112640\d368	908-shd-details.DGN	DRAWN -	REVISED -
	PLOT SCALE = 50.7353' / IN.	CHECKED -	REVISED -
	PLOT DATE = Sep 07, 2009 - 02:16:53 PM	DATE -	REVISED -

**STATE OF ILLINOIS  
DEPARTMENT OF TRANSPORTATION**

**TYPICAL SECTIONS**

SCALE: \_\_\_\_\_ SHEET NO. \_\_\_ OF \_\_\_ SHEETS STA. \_\_\_\_\_ TO STA. \_\_\_\_\_

F.A. RTE. I-80	SECTION	COUNTY	TOTAL SHEETS	SHEET NO.
**		BUREAU	344	8
			CONTRACT NO. 66908	
ILLINOIS FED. AID PROJECT				



P:\602429\I-80\road\602429.20\_b\Z03703TYP1.dgn

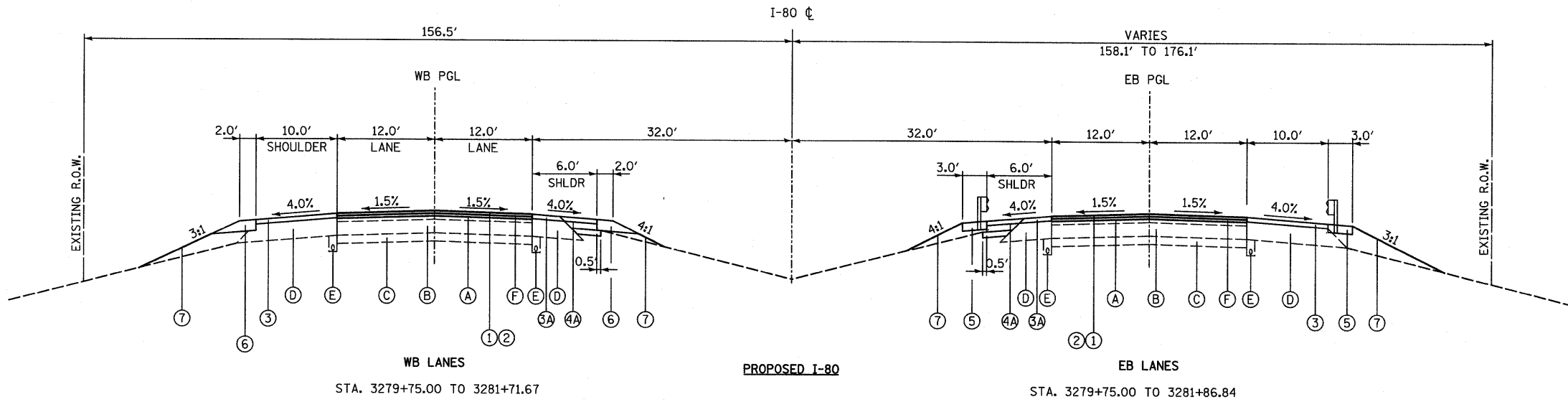

**EXISTING LEGEND**

- (A) EXISTING HOT-MIX ASPHALT OVERLAYS
- (B) EXISTING 10" PCC PAVEMENT
- (C) EXISTING 6" GRANULAR SUB-BASE
- (D) EXISTING STABILIZED SHOULDERS
- (E) EXISTING 4" PIPE UNDERDRAIN
- (F) EXISTING 2" POLYMERIZED SURFACE COURSE

**PROPOSED LEGEND**

- (1) MAINLINE RESURFACING, 1 3/4" INCLUDES: 1 3/4" POLYMERIZED HOT-MIX ASPHALT SURFACE COURSE, MIX "D", N105
- (2) POLYMERIZED LEVELING BINDER (MACHINE METHOD), N90 (3/4" MIN. VARIABLE DEPTH) (AS NECESSARY)
- (3) SHOULDER RESURFACING, 1 3/4" INCLUDES: 1 3/4" HOT-MIX ASPHALT SURFACE COURSE, MIX "C", N50
- (3A) SHOULDER RESURFACING, 1 3/4" INCLUDES: 1 3/4" POLYMERIZED HOT-MIX ASPHALT SURFACE COURSE, MIX "D", N105
- (4) FULL-DEPTH HOT-MIX ASPHALT SHOULDERS, 12" INCLUDES: 1 3/4" HOT-MIX ASPHALT SURFACE COURSE, MIX "C", N50 10 1/4" HOT-MIX ASPHALT BINDER COURSE, IL-19.0, N50 6" AGGREGATE BASE COURSE, TYPE A
- (4A) FULL-DEPTH HOT-MIX ASPHALT SHOULDERS, 12" INCLUDES: 1 3/4" POLYMERIZED HOT-MIX ASPHALT SURFACE COURSE, MIX "D", N105 10 1/4" HOT-MIX ASPHALT BINDER COURSE, IL-19.0, N90 6" AGGREGATE BASE COURSE, TYPE A
- (5) GUARDRAIL STABILIZATION HOT-MIX ASPHALT SHOULDERS 6"
- (6) AGGREGATE SHOULDERS, TYPE B 8"
- (7) PROPOSED GROUND LINE

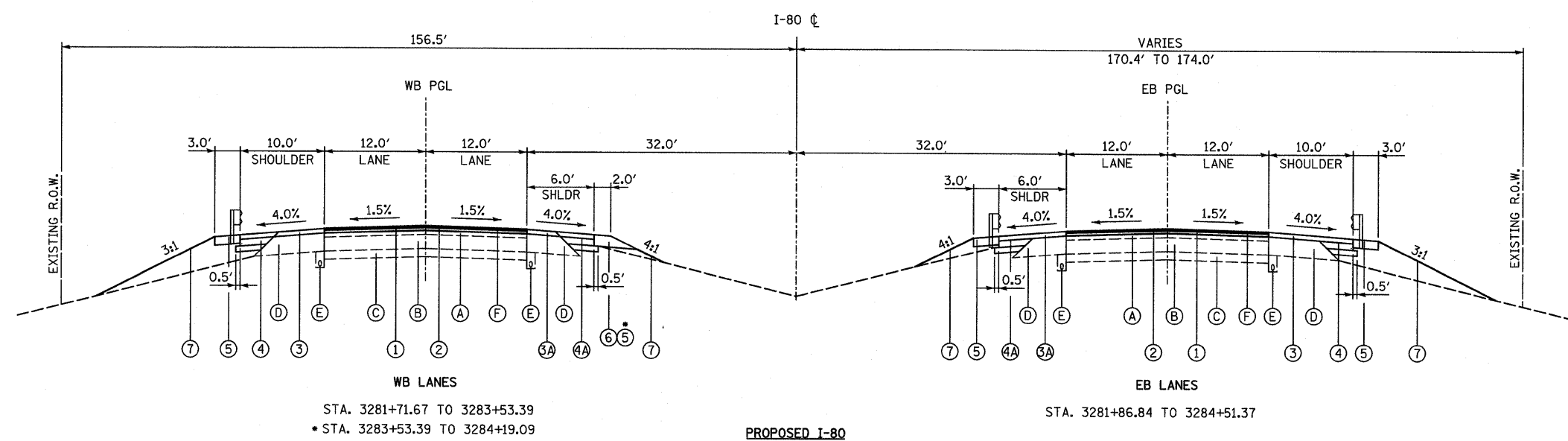

BRIDGE OMISSION:  
EASTBOUND: STA. 3284+51.37 TO 3286+23.20  
WESTBOUND: STA. 3284+19.09 TO 3285+91.42

**TYLIN INTERNATIONAL**

USER NAME = #USER#	DESIGNED - CAC	REVISED -
PLOT SCALE = #SCALE#	DRAWN - CAC	REVISED -
PLOT DATE = 8/14/2009	CHECKED - JDF	REVISED -
	DATE - 08/14/2009	REVISED -

**STATE OF ILLINOIS  
DEPARTMENT OF TRANSPORTATION**

**F.A.I. ROUTE 80 (I-80)  
EXISTING AND PROPOSED TYPICAL SECTIONS**

SCALE: NONE SHEET NO. 1 OF 2 SHEETS STA. TO STA.

F.A.I. RTE. 80	SECTION	COUNTY	TOTAL SHEETS	SHEET NO.
		BUREAU	99	9
FED. ROAD DIST. NO. ILLINOIS FED. AID PROJECT			CONTRACT NO. 66908	
• 06-17BR & BR-1,7VB-M, 6BR & 6, 7 RS-1 & 11				

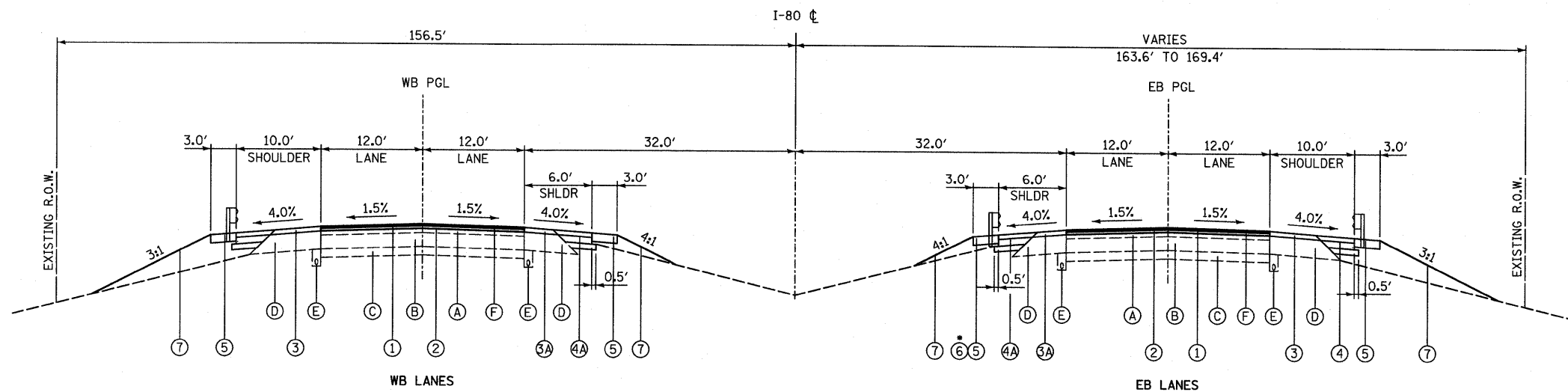

BRIDGE OMISSION: STA. 3284+19.09 TO STA. 3285+91.42  
 STA. 3285+91.42 TO STA. 3288+32.46

**PROPOSED I-80**

BRIDGE OMISSION:  
 EASTBOUND: STA. 3284+51.37 TO STA. 3286+23.20  
 WESTBOUND: STA. 3284+19.09 TO STA. 3285+91.42

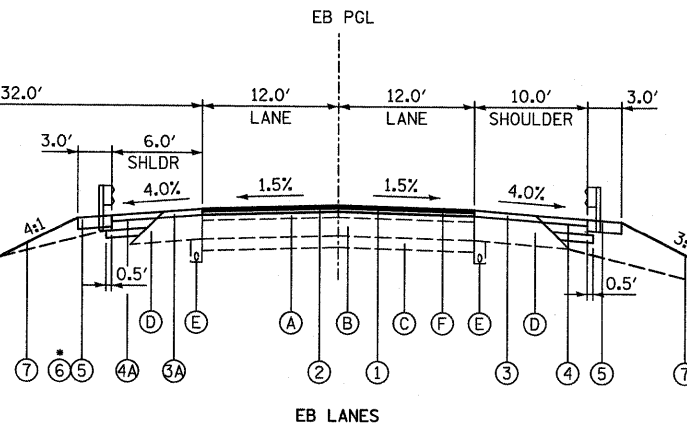

BRIDGE OMISSION: STA. 3284+51.37 TO STA. 3286+23.20  
 STA. 3286+23.20 TO STA. 3286+88.98  
 • STA. 3286+88.98 TO STA. 3288+48.17

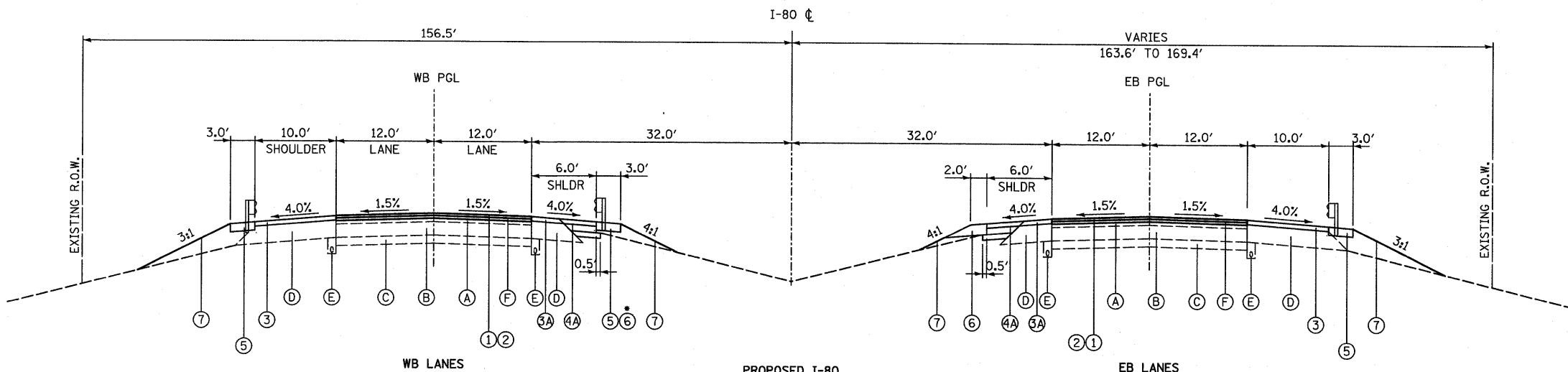

STA. 3288+32.46 TO STA. 3291+66.71  
 • STA. 3288+66.71 TO STA. 3292+50.00

**PROPOSED I-80**

STA. 3288+48.17 TO STA. 3292+50.00

**EXISTING LEGEND**

- (A) EXISTING HOT-MIX ASPHALT OVERLAYS
- (B) EXISTING 10" PCC PAVEMENT
- (C) EXISTING 6" GRANULAR SUB-BASE
- (D) EXISTING STABILIZED SHOULDERS
- (E) EXISTING 4" PIPE UNDERDRAIN
- (F) EXISTING 2" POLYMERIZED SURFACE COURSE

**PROPOSED LEGEND**

- (1) MAINLINE RESURFACING, 1 3/4" INCLUDES:  
1 3/4" POLYMERIZED HOT-MIX ASPHALT SURFACE COURSE, MIX "D", N105
- (2) POLYMERIZED LEVELING BINDER (MACHINE METHOD), N90 (3/4" MIN. VARIABLE DEPTH) (AS NECESSARY)
- (3) SHOULDER RESURFACING, 1 3/4" INCLUDES:  
1 3/4" HOT-MIX ASPHALT SURFACE COURSE, MIX "C", N50
- (3A) SHOULDER RESURFACING, 1 3/4" INCLUDES:  
1 3/4" POLYMERIZED HOT-MIX ASPHALT SURFACE COURSE, MIX "D", N105
- (4) FULL-DEPTH HOT-MIX ASPHALT SHOULDERS, 12" INCLUDES:  
1 3/4" HOT-MIX ASPHALT SURFACE COURSE, MIX "C", N50  
10 1/4" HOT-MIX ASPHALT BINDER COURSE, IL-19.0, N50  
6" AGGREGATE BASE COURSE, TYPE A
- (4A) FULL-DEPTH HOT-MIX ASPHALT SHOULDERS, 12" INCLUDES:  
1 3/4" POLYMERIZED HOT-MIX ASPHALT SURFACE COURSE, MIX "D", N105  
10 1/4" HOT-MIX ASPHALT BINDER COURSE, IL-19.0, N90  
6" AGGREGATE BASE COURSE, TYPE A
- (5) GUARDRAIL STABILIZATION HOT-MIX ASPHALT SHOULDERS 6"
- (6) AGGREGATE SHOULDERS, TYPE B 8"
- (7) PROPOSED GROUND LINE

TYLIN INTERNATIONAL

USER NAME = #USER#	DESIGNED - CAC	REVISED -
PLOT SCALE = #SCALE#	DRAWN - CAC	REVISED -
PLOT DATE = 8/14/2009	CHECKED - JDF	REVISED -
	DATE - 08/14/2009	REVISED -

STATE OF ILLINOIS  
 DEPARTMENT OF TRANSPORTATION

F.A.I. ROUTE 80 (I-80)  
 EXISTING AND PROPOSED TYPICAL SECTIONS

SCALE: NONE SHEET NO. 2 OF 2 SHEETS STA. TO STA.

F.A.I. RTE.	SECTION	COUNTY	TOTAL SHEETS	SHEET NO.
80	*	BUREAU	394	10
CONTRACT NO. 66908				

FED. ROAD DIST. NO. ILLINOIS FED. AID PROJECT  
 • 06-17BR & BR-1,7VB-M, GBR & 6, 7 RS-1 & 11

P:\602429\I-80\road\602429.30\_C\201993TYP01.dgn

3:53:01 PM 8/14/2009

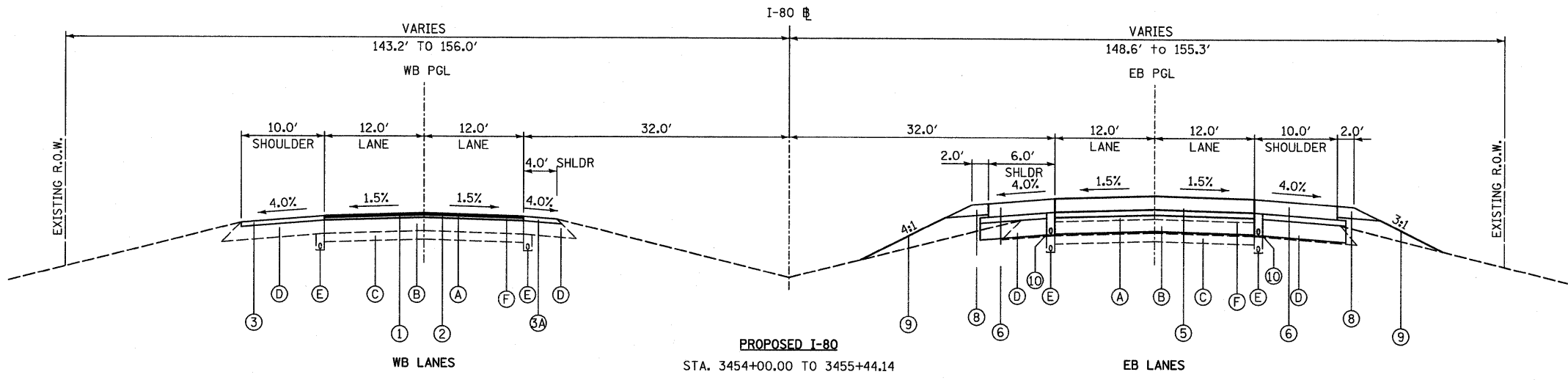

**PROPOSED I-80**  
STA. 3454+00.00 TO 3455+44.14

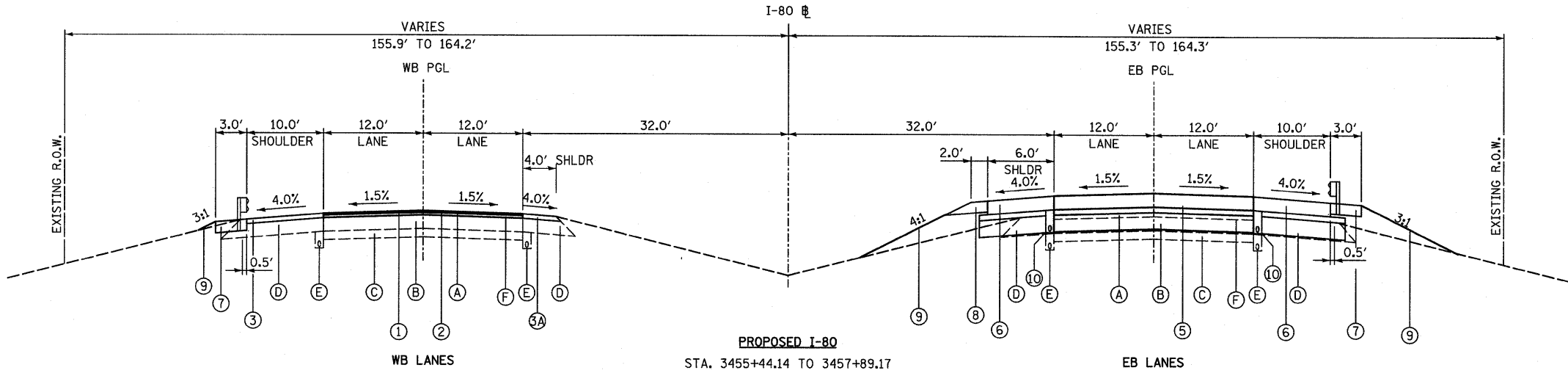

**PROPOSED I-80**  
STA. 3455+44.14 TO 3457+89.17

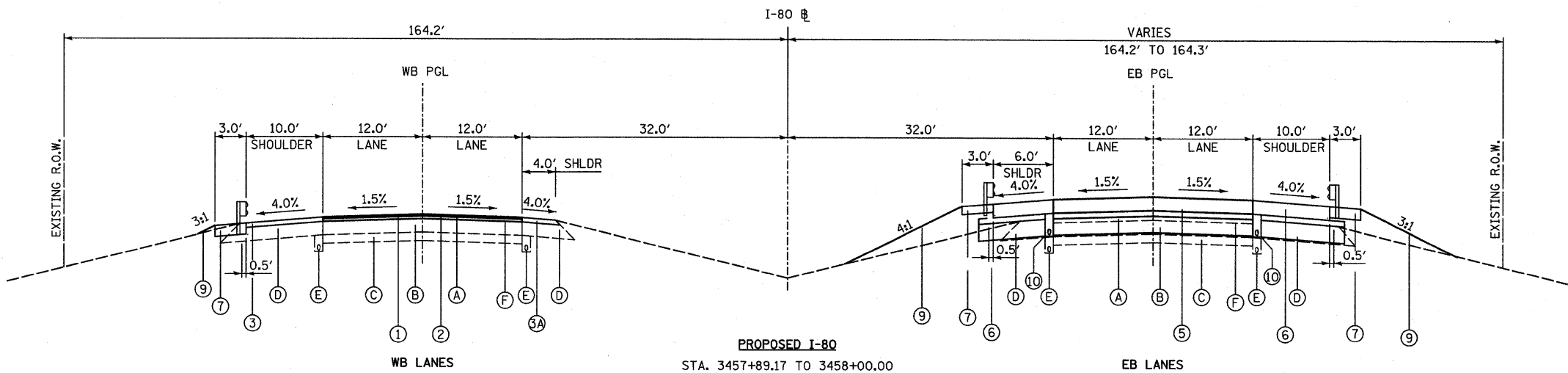

**PROPOSED I-80**  
STA. 3457+89.17 TO 3458+00.00

**EXISTING LEGEND**

- (A) EXISTING HOT-MIX ASPHALT OVERLAYS
- (B) EXISTING 10" PCC PAVEMENT
- (C) EXISTING 6" GRANULAR SUB-BASE
- (D) EXISTING STABILIZED SHOULDERS
- (E) EXISTING 4" PIPE UNDERDRAIN
- (F) EXISTING 2" POLYMERIZED SURFACE COURSE

**PROPOSED LEGEND**

- (1) MAINLINE RESURFACING, 1 3/4" INCLUDES: 1 3/4" POLYMERIZED HOT-MIX ASPHALT SURFACE COURSE, MIX "D", N105
- (2) POLYMERIZED LEVELING BINDER (MACHINE METHOD), N90 (3/4" MIN. VARIABLE DEPTH) (AS NECESSARY)
- (3) SHOULDER RESURFACING, 1 3/4" INCLUDES: 1 3/4" HOT-MIX ASPHALT SURFACE COURSE, MIX "C", N50
- (3A) SHOULDER RESURFACING, 1 3/4" INCLUDES: 1 3/4" POLYMERIZED HOT-MIX ASPHALT SURFACE COURSE, MIX "D", N105
- (4) FULL-DEPTH HOT-MIX ASPHALT SHOULDERS, 12" INCLUDES: 1 3/4" HOT-MIX ASPHALT SURFACE COURSE, MIX "C", N50 10 1/4" HOT-MIX ASPHALT BINDER COURSE, IL-19.0, N50 6" AGGREGATE BASE COURSE, TYPE A
- (4A) FULL-DEPTH HOT-MIX ASPHALT SHOULDERS, 12" INCLUDES: 1 3/4" POLYMERIZED HOT-MIX ASPHALT SURFACE COURSE, MIX "D", N105 10 1/4" HOT-MIX ASPHALT BINDER COURSE, IL-19.0, N90 6" AGGREGATE BASE COURSE, TYPE A
- (5) FULL-DEPTH CRC PAVEMENT INCLUDES: 10" CONTINUOUSLY REINFORCED PORTLAND CEMENT CONCRETE PAVEMENT 4" STABILIZED SUB-BASE (HMA) 12" AGGREGATE SUBGRADE
- (6) FULL-DEPTH CONCRETE SHOULDERS INCLUDES: 10" PORTLAND CEMENT CONCRETE SHOULDERS 4" SUB-BASE GRANULAR MATERIAL, TYPE C 12" AGGREGATE SUBGRADE
- (7) GUARDRAIL STABILIZATION HOT-MIX ASPHALT SHOULDERS 6"
- (8) AGGREGATE SHOULDERS, TYPE B 8"
- (9) PROPOSED GROUND LINE
- (10) PROPOSED 4" PIPE UNDERDRAIN

**TYLIN INTERNATIONAL**

USER NAME = #USER#	DESIGNED - CAC	REVISED -
PLOT SCALE = #SCALE#	DRAWN - CAC	REVISED -
PLOT DATE = 8/14/2009	CHECKED - JDF	REVISED -
	DATE - 08/14/2009	REVISED -

**STATE OF ILLINOIS  
DEPARTMENT OF TRANSPORTATION**

**F.A.I. ROUTE 80 (I-80)  
EXISTING AND PROPOSED TYPICAL SECTIONS**

SCALE:	SHEET NO.	OF SHEETS	STA.	TO STA.
--------	-----------	-----------	------	---------

F.A.I. RTE.	SECTION	COUNTY	TOTAL SHEETS	SHEET NO.
80			394	11
FED. ROAD DIST. NO. [ILLINOIS] FED. AID PROJECT			CONTRACT NO. 66908	
• 06-C7BR & BR-1,7VB-M, 6BR & 6, 7 RS-1 & 11				

P:\02429\I-80\Road\602429.30\_C\Z01993TYP02.dgn  
 8/14/2009 3:54:33 PM

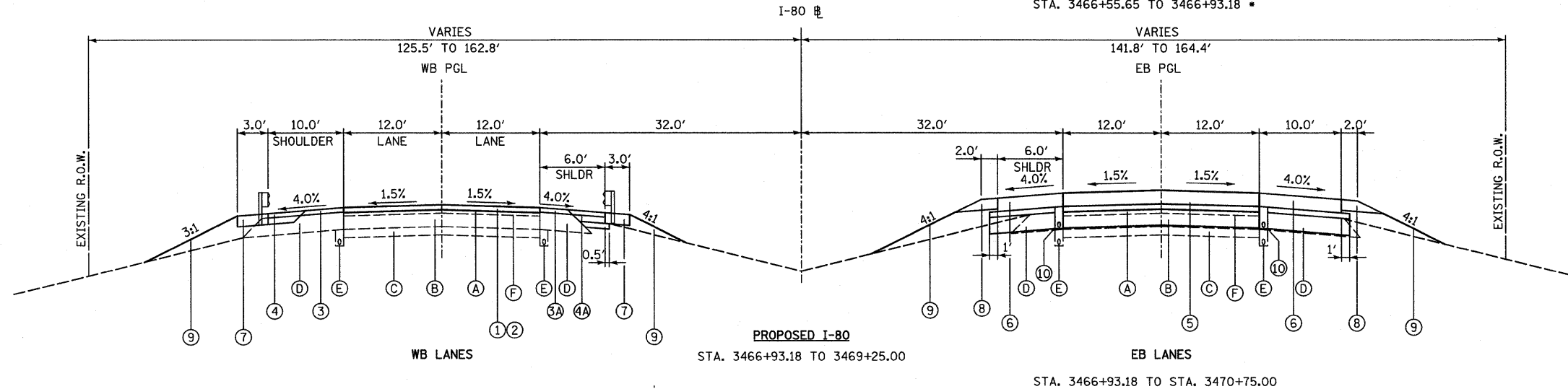
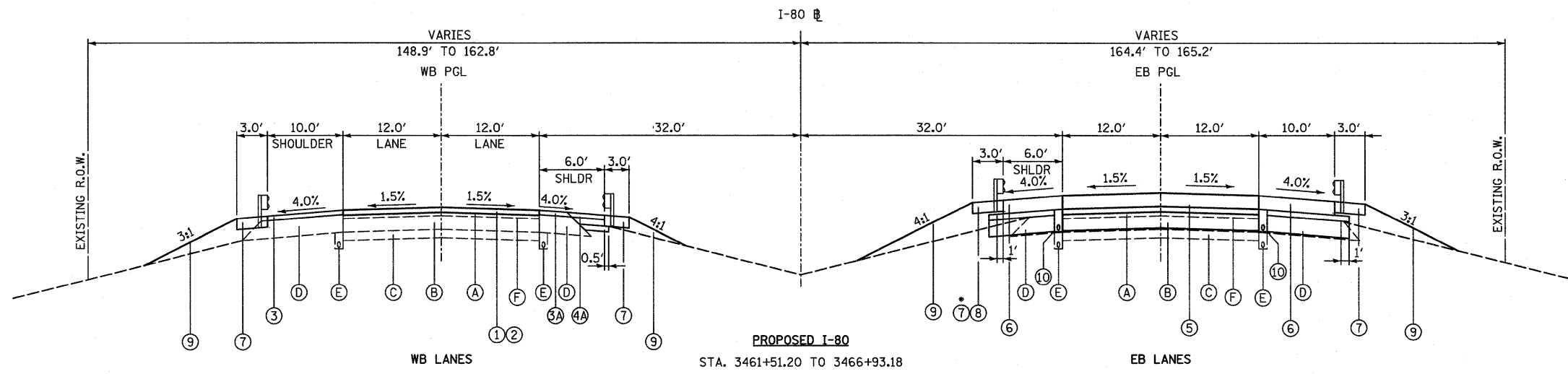
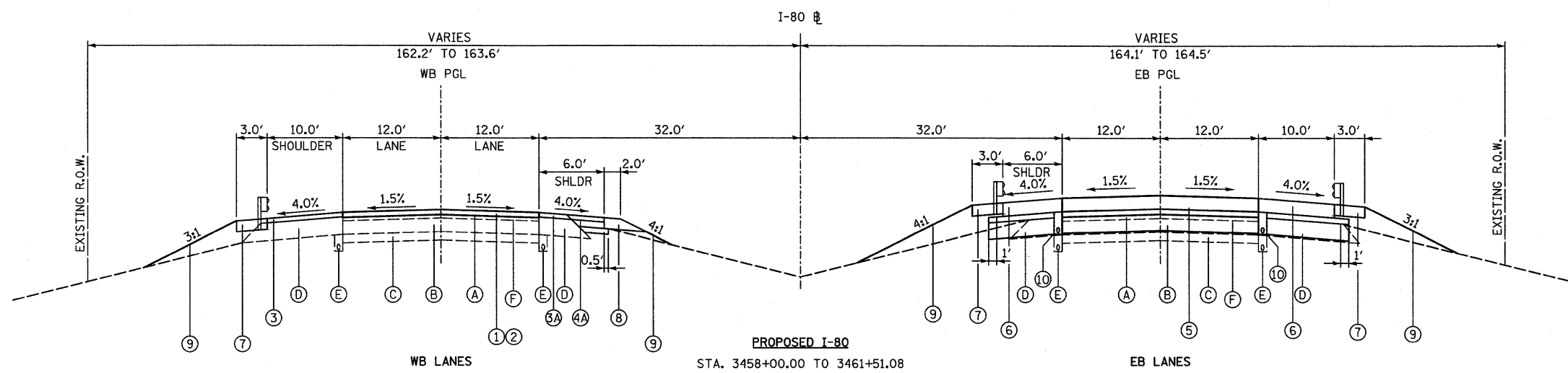

**EXISTING LEGEND**

- (A) EXISTING HOT-MIX ASPHALT OVERLAYS
- (B) EXISTING 10" PCC PAVEMENT
- (C) EXISTING 6" GRANULAR SUB-BASE
- (D) EXISTING STABILIZED SHOULDERS
- (E) EXISTING 4" PIPE UNDERDRAIN
- (F) EXISTING 2" POLYMERIZED SURFACE COURSE

**PROPOSED LEGEND**

- (1) MAINLINE RESURFACING, 1 3/4" INCLUDES: 1 3/4" POLYMERIZED HOT-MIX ASPHALT SURFACE COURSE, MIX "D", N105
- (2) POLYMERIZED LEVELING BINDER (MACHINE METHOD), N90 (3/4" MIN. VARIABLE DEPTH) (AS NECESSARY)
- (3) SHOULDER RESURFACING, 1 3/4" INCLUDES: 1 3/4" HOT-MIX ASPHALT SURFACE COURSE, MIX "C", N50
- (3A) SHOULDER RESURFACING, 1 3/4" INCLUDES: 1 3/4" POLYMERIZED HOT-MIX ASPHALT SURFACE COURSE, MIX "D", N105
- (4) FULL-DEPTH HOT-MIX ASPHALT SHOULDERS, 12" INCLUDES: 1 3/4" HOT-MIX ASPHALT SURFACE COURSE, MIX "C", N50 10 1/4" HOT-MIX ASPHALT BINDER COURSE, IL-19.0, N50 6" AGGREGATE BASE COURSE, TYPE A
- (4A) FULL-DEPTH HOT-MIX ASPHALT SHOULDERS, 12" INCLUDES: 1 3/4" POLYMERIZED HOT-MIX ASPHALT SURFACE COURSE, MIX "D", N105 10 1/4" HOT-MIX ASPHALT BINDER COURSE, IL-19.0, N90 6" AGGREGATE BASE COURSE, TYPE A
- (5) FULL-DEPTH CRC PAVEMENT INCLUDES: 10" CONTINUOUSLY REINFORCED PORTLAND CEMENT CONCRETE PAVEMENT 4" STABILIZED SUB-BASE (HMA) 12" AGGREGATE SUBGRADE
- (6) FULL-DEPTH CONCRETE SHOULDERS INCLUDES: 10" PORTLAND CEMENT CONCRETE SHOULDERS 4" SUB-BASE GRANULAR MATERIAL, TYPE C 12" AGGREGATE SUBGRADE
- (7) GUARDRAIL STABILIZATION HOT-MIX ASPHALT SHOULDERS 6"
- (8) AGGREGATE SHOULDERS, TYPE B 8"
- (9) PROPOSED GROUND LINE
- (10) PROPOSED 4" PIPE UNDERDRAIN

**TYLIN INTERNATIONAL**

USER NAME = *USER*	DESIGNED - CAC	REVISED -
PLOT SCALE = *SCALE*	DRAWN - CAC	REVISED -
PLOT DATE = 8/14/2009	CHECKED - JDF	REVISED -
	DATE - 08/14/2009	REVISED -

**STATE OF ILLINOIS  
DEPARTMENT OF TRANSPORTATION**

**F.A.I. ROUTE 80 (I-80)  
EXISTING AND PROPOSED TYPICAL SECTIONS**

SCALE:	SHEET NO. OF SHEETS	STA. TO STA.	F.A.I. RTE. 80	SECTION *	COUNTY BUREAU	TOTAL SHEETS 144	SHEET NO. 12
			CONTRACT NO. 66908		ILLINOIS FED. AID PROJECT		
			* 06-17BR & BR-1,TVB-M, 6BR & 6, 7 RS-1 & IJ				

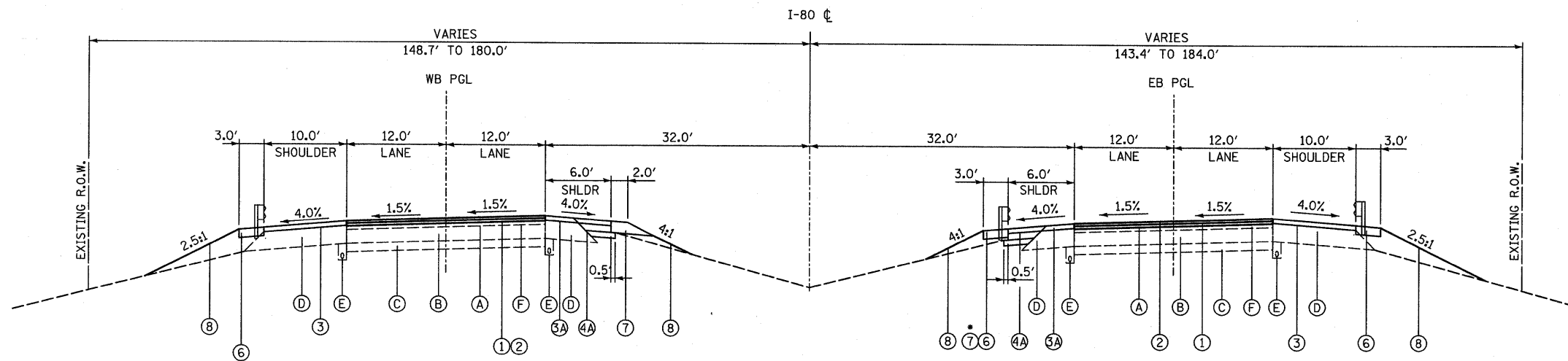

**PROPOSED I-80**  
 STA. 3603+00.00 TO 3604+86.47      STA. 3603+00.00 TO 3603+21.13 •

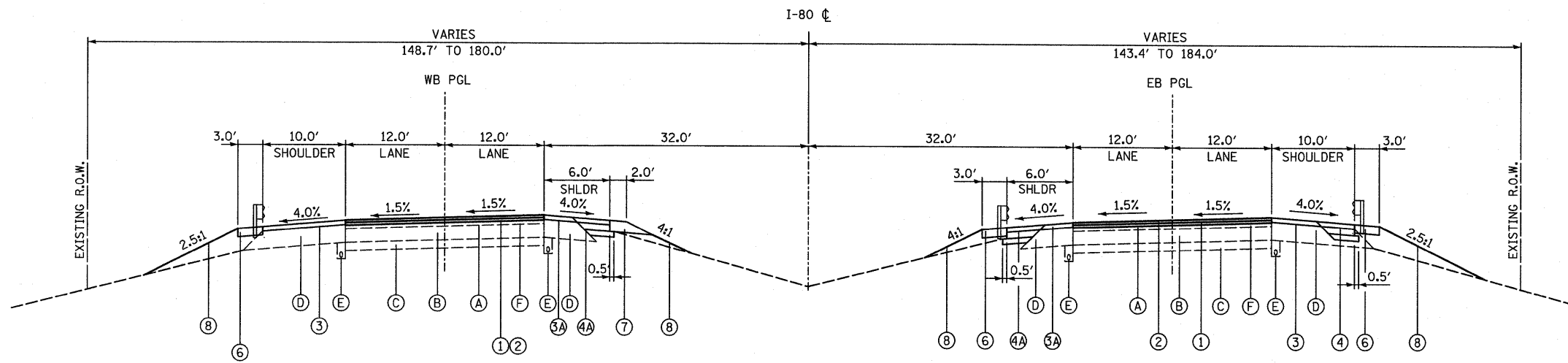

**PROPOSED I-80**  
 STA. 3604+86.47 TO 3606+14.56

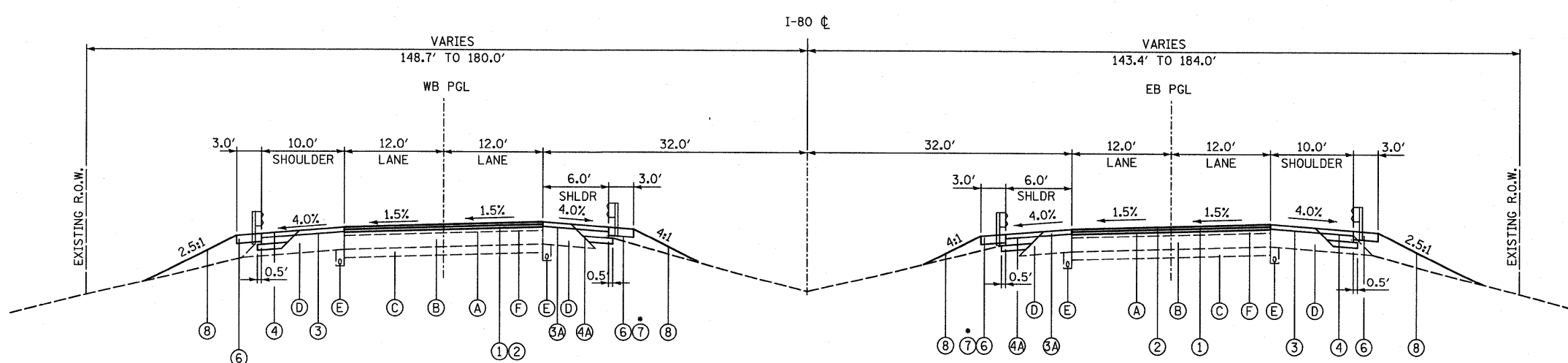

**PROPOSED I-80**  
 STA. 3606+14.56 TO 3607+65.38 •      STA. 3606+14.56 TO 3607+66.39  
 BRIDGE OMISSION STA. 3607+66.39 TO 3610+46.89      STA. 3610+89.69 TO 3611+18.59 •  
 STA. 3610+46.89 TO 3611+18.59

**EXISTING LEGEND**

- (A) EXISTING BITUMINOUS OVERLAYS
- (B) EXISTING 10" PCC PAVEMENT
- (C) EXISTING 6" GRANULAR SUB-BASE
- (D) EXISTING STABILIZED SHOULDERS
- (E) EXISTING 4" PIPE UNDERDRAIN
- (F) EXISTING 2" POLYMERIZED SURFACE COURSE

**PROPOSED LEGEND**

- (1) MAINLINE RESURFACING, 1 3/4" INCLUDES: 1 3/4" POLYMERIZED HOT-MIX ASPHALT SURFACE COURSE, MIX "D", N105
- (2) POLYMERIZED LEVELING BINDER (MACHINE METHOD), N90 (3/4" MIN. VARIABLE DEPTH) (AS NECESSARY)
- (3) SHOULDER RESURFACING, 1 3/4" INCLUDES: 1 3/4" HOT-MIX ASPHALT SURFACE COURSE, MIX "C", N50
- (3A) SHOULDER RESURFACING, 1 3/4" INCLUDES: 1 3/4" POLYMERIZED HOT-MIX ASPHALT SURFACE COURSE, MIX "D", N105
- (4) FULL-DEPTH HOT-MIX ASPHALT SHOULDERS, 12" INCLUDES: 1 3/4" HOT-MIX ASPHALT SURFACE COURSE, MIX "C", N50 10 1/4" HOT-MIX ASPHALT BINDER COURSE, IL-19.0, N50 6" AGGREGATE BASE COURSE, TYPE A
- (4A) FULL-DEPTH HOT-MIX ASPHALT SHOULDERS, 12" INCLUDES: 1 3/4" POLYMERIZED HOT-MIX ASPHALT SURFACE COURSE, MIX "D", N105 10 1/4" HOT-MIX ASPHALT BINDER COURSE, IL-19.0, N90 6" AGGREGATE BASE COURSE, TYPE A
- (5) FULL-DEPTH HMA PAVEMENT, 21" INCLUDES: 1 3/4" POLYMERIZED HOT-MIX ASPHALT SURFACE COURSE, MIX "D", N105 2 3/4" POLYMERIZED HOT-MIX ASPHALT BINDER COURSE, N105 12 3/4" HOT-MIX ASPHALT BINDER COURSE, IL-19, N90 4" HOT-MIX ASPHALT BINDER COURSE, N70 12" AGGREGATE BASE
- (6) GUARDRAIL STABILIZATION HOT-MIX ASPHALT SHOULDERS 6"
- (7) AGGREGATE SHOULDERS, TYPE B 8"
- (8) PROPOSED GROUND LINE

**TYLIN INTERNATIONAL**

USER NAME = #USER#	DESIGNED - CAC	REVISED -
PLOT SCALE = #SCALE#	DRAWN - CAC	REVISED -
PLOT DATE = 8/14/2009	CHECKED - JDF	REVISED -
	DATE - 08/14/2009	REVISED -

**STATE OF ILLINOIS  
 DEPARTMENT OF TRANSPORTATION**

**F.A.I. ROUTE 80 (I-80)  
 PROPOSED TYPICAL SECTIONS SHEET 1 OF 2**

SCALE:	SHEET NO.	OF SHEETS	STA.	TO STA.

F.A.I. RTE. 80	SECTION	COUNTY	TOTAL SHEETS	SHEET NO.
			394	13
FED. ROAD DIST. NO.	(ILLINOIS) FED. AID PROJECT	BUREAU	CONTRACT NO. 66908	
	• 06-17BR & BR-1, TVB-M, 6BR & 6, 7 RS-1 & 1			

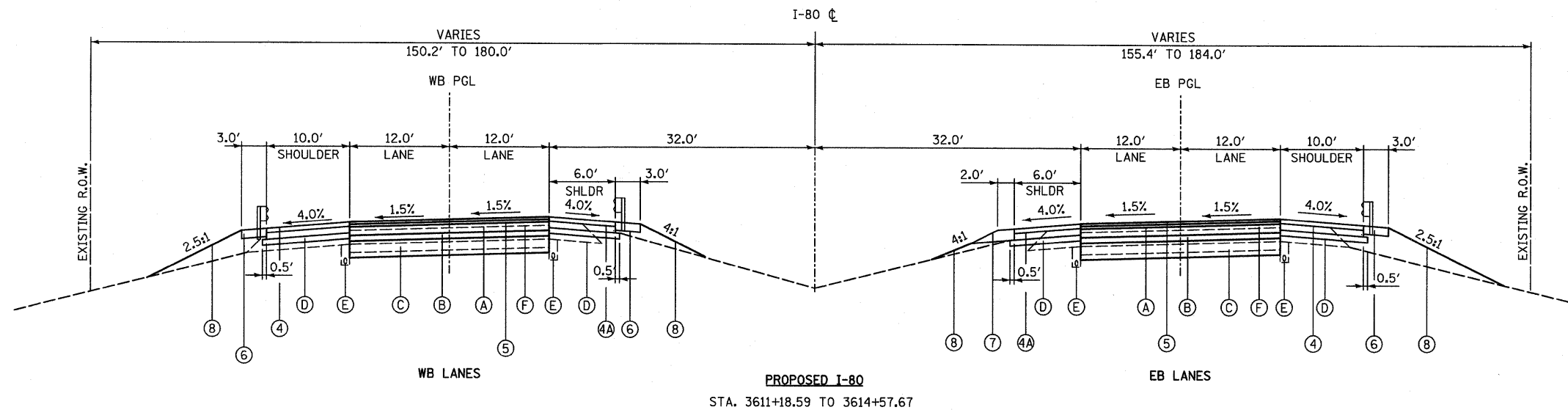

PROPOSED I-80  
STA. 3611+18.59 TO 3614+57.67

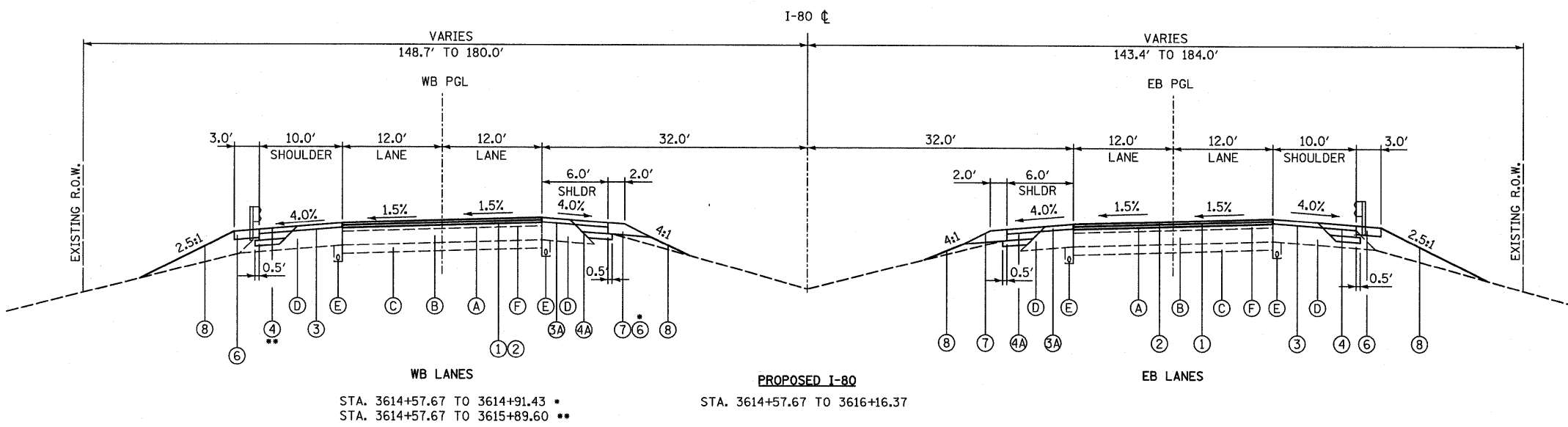

PROPOSED I-80  
STA. 3614+57.67 TO 3614+91.43 \*  
STA. 3614+57.67 TO 3615+89.60 \*\*

PROPOSED I-80  
STA. 3614+57.67 TO 3616+16.37

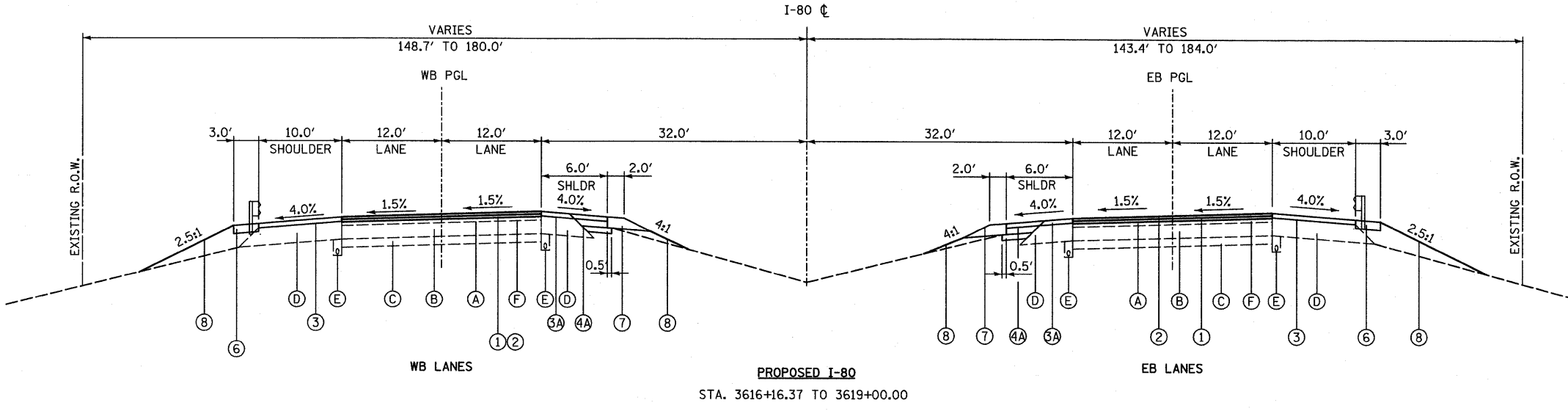

PROPOSED I-80  
STA. 3616+16.37 TO 3619+00.00

**EXISTING LEGEND**

- (A) EXISTING BITUMINOUS OVERLAYS
- (B) EXISTING 10" PCC PAVEMENT
- (C) EXISTING 6" GRANULAR SUB-BASE
- (D) EXISTING STABILIZED SHOULDERS
- (E) EXISTING 4" PIPE UNDERDRAIN
- (F) EXISTING 2" POLYMERIZED SURFACE COURSE

**PROPOSED LEGEND**

- (1) MAINLINE RESURFACING, 1 3/4" INCLUDES: 1 3/4" POLYMERIZED HOT-MIX ASPHALT SURFACE COURSE, MIX "D", N105
- (2) POLYMERIZED LEVELING BINDER (MACHINE METHOD), N90 (3/4" MIN. VARIABLE DEPTH) (AS NECESSARY)
- (3) SHOULDER RESURFACING, 1 3/4" INCLUDES: 1 3/4" HOT-MIX ASPHALT SURFACE COURSE, MIX "C", N50
- (3A) SHOULDER RESURFACING, 1 3/4" INCLUDES: 1 3/4" POLYMERIZED HOT-MIX ASPHALT SURFACE COURSE, MIX "D", N105
- (4) FULL-DEPTH HOT-MIX ASPHALT SHOULDERS, 12" INCLUDES: 1 3/4" HOT-MIX ASPHALT SURFACE COURSE, MIX "C", N50 10/4" HOT-MIX ASPHALT BINDER COURSE, IL-19.0, N50 6" AGGREGATE BASE COURSE, TYPE A
- (4A) FULL-DEPTH HOT-MIX ASPHALT SHOULDERS, 12" INCLUDES: 1 3/4" POLYMERIZED HOT-MIX ASPHALT SURFACE COURSE, MIX "D", N105 10/4" HOT-MIX ASPHALT BINDER COURSE, IL-19.0, N90 6" AGGREGATE BASE COURSE, TYPE A
- (5) FULL-DEPTH HMA PAVEMENT, 21" INCLUDES: 1 3/4" POLYMERIZED HOT-MIX ASPHALT SURFACE COURSE, MIX "D", N105 2 3/4" POLYMERIZED HOT-MIX ASPHALT BINDER COURSE, N105 12 3/4" HOT-MIX ASPHALT BINDER COURSE, IL-19, N90 4" HOT-MIX ASPHALT BINDER COURSE, N70 12" AGGREGATE BASE
- (6) GUARDRAIL STABILIZATION HOT-MIX ASPHALT SHOULDERS 6"
- (7) AGGREGATE SHOULDERS, TYPE B 8"
- (8) PROPOSED GROUND LINE

TYLIN INTERNATIONAL

USER NAME = *USER*	DESIGNED - CAC	REVISED -
PLOT SCALE = *SCALE*	DRAWN - CAC	REVISED -
PLOT DATE = 8/14/2009	CHECKED - JDF	REVISED -
	DATE - 08/14/2009	REVISED -

STATE OF ILLINOIS  
DEPARTMENT OF TRANSPORTATION

F.A.I. ROUTE 80 (I-80)  
PROPOSED TYPICAL SECTIONS SHEET 2 OF 2

SCALE:	SHEET NO.	OF SHEETS	STA.	TO STA.
--------	-----------	-----------	------	---------

F.A.I. RTE.	SECTION	COUNTY	TOTAL SHEETS	SHEET NO.
80	*	BUREAU	344	14
CONTRACT NO. 66908				

FED. ROAD DIST. NO. ILLINOIS FED. AID PROJECT  
\* 06-ETBR & BR-1,7VB-M, 6BR & 6, 7 RS-1 & I

MAINLINE SCHEDULE**													
LOCATION	STA TO STA	WIDTH	LENGTH	AREA	POLYMERIZED HMA SURFACE COURSE MIX "D", N 105		1 3/4" SURFACE 10' SHLDR MIX C	POLY. BIT MATL PR CT	AGG PR CT	SHLD RUMBLE STRIP	AGG SHLD TY B	MIX FOR CR, JTS, & FLANGEWAYS	LEVEL BINDER (HM)
					24' MAINLINE TON	4' SHOULDER TON							
EB LANE													
1405+64 TO 1429+35	TO	24	2371.2	6323.2	620	103	258	1053.9	12.6	4742.4	157.5	1.90	3.16
OMIT SN 006-0024 (PROP SN 006-0170)													
1442+10 TO 1603+62	TO	24	16151.8	43071.47	4221	704	1759	7178.6	86.1	32303.6	1073.0	12.92	21.54
OMIT SN 006-0026 (PROP SN 006-0171)													
1620+37 TO 1752+64	TO	24	13227	35272	3457	576	1440	5878.7	70.5	26454.0	878.7	10.58	17.64
OMIT SN 006-0028 & 006-0030 (PROP SN 006-0172)													
1768+64 TO 1803+19	TO	24	3455	9213.333	903	150	376	1535.6	18.4	6910.0	229.5	2.76	4.61
WB LANE													
1405+64 TO 1429+35	TO	24	2371.2	6323.2	620	103	258	1053.9	12.6	4742.4	157.5	1.90	3.16
OMIT SN 006-0025 (PROP SN 006-0173)													
1442+10 TO 1607+62	TO	24	16551.8	44138.13	4326	721	1802	7356.4	88.3	33103.6	1099.6	13.24	22.07
OMIT SN 006-0027 (PROP SN 006-0174)													
1619+87 TO 1752+64	TO	24	13277	35405.33	3470	578	1446	5900.9	70.8	26554.0	882.1	10.62	17.70
OMIT SN 006-0029 & 006-0031 (PROP SN 006-0175)													
1768+64 TO 1803+19	TO	24	3455	9213.333	903	150	376	1535.6	18.4	6910.0	229.5	2.76	4.61
SUB-TOTAL			70860	188960	18518	3086	7716	31493	378	141720	4708	57	94
TOTAL			70860	188960	22253		7716	31493	378	141720	4708	57	94

\*\* See Separate Schedules For Each Structure \*\*

STA EOS.:  
 STA 1544+87.78(BK) = 1544+88.38(AH)  
 STA 1660+83.19(BK) = 1660+82.35(AH)

PAVEMENT MARKING SCHEDULE**														
LOCATION STATION TO STATION	LENGTH	THPL PVT MK LINE WHITE 4"	THPL PVT MK LINE YELLOW 4"	TEMP PVMT MK LN WHITE 4"	TEMP PVMT MK LN YELLOW 4"	TEMP PVMT MK LN WHITE 6"	RAISED REFLEC PVT MK	RAISED REFLEC PVT MK REMO	SHORT-TERM PVMT. MARK.	WORK-ZONE PVMT. MARK. REM.	PREFORM PL PVT MK TY B INLAY 6"	DELINEATOR	DELINEATOR REMOVAL	
		FOOT	FOOT	FOOT	FOOT	FOOT	EACH	EACH	FOOT	SQ FT	FOOT	EACH	EACH	
1405+64 TO 1429+35	2371	2371	2371	2472	2472	593	59	59	237	78	593	8	8	
OMIT SN 006-0024 (PROP SN 006-0170)														
1442+10 TO 1603+62	16152	16152	16152	16051	16051	4038	404	404	1615	533	4038	54	54	
OMIT SN 006-0026 (PROP SN 006-0171)														
1620+37 TO 1752+64	13227	13227	13227	13716	13716	3307	331	331	1323	436	3307	44	44	
OMIT SN 006-0028 & 006-0030 (PROP SN 006-0172)														
1768+64 TO 1803+19	3455	3455	3455	4955	4955	864	86	86	346	114	864	12	12	
WB LANE														
1405+64 TO 1429+35	2371	2371	2371	2472	2472	593	59	59	237	78	593	8	8	
OMIT SN 006-0025 (PROP SN 006-0173)														
1442+10 TO 1607+62	16552	16552	16552	16051	16051	4138	414	414	1655	546	4138	55	55	
OMIT SN 006-0027 (PROP SN 006-0174)														
1619+87 TO 1752+64	13277	13277	13277	13378	13378	3319	332	332	1328	438	3319	44	44	
OMIT SN 006-0029 & 006-0031 (PROP SN 006-0175)														
1768+64 TO 1803+19	3455	3455	3455	3355	3355	864	86	86	346	114	864	12	12	
SUBTOTAL		70860	70860	70860	72450	72450	17715	1772	1772	7086	2338	17715	236	236
TOTAL		70860	141720	70860	144900	144900	17715	1772	1772	7086	2338	17715	236	236

\*\* See Separate Schedules For Each Structure \*\*

STA EOS.:  
 STA 1544+87.78(BK) = 1544+88.38(AH)  
 STA 1660+83.19(BK) = 1660+82.35(AH)

FILE NAME =	USER NAME = braboygo	DESIGNED -	REVISED -	<b>STATE OF ILLINOIS DEPARTMENT OF TRANSPORTATION</b>	<b>SCHEDULE OF QUANTITIES</b>	F.A.I. RTE.	SECTION	COUNTY	TOTAL SHEETS	SHEET NO.	
ct:\p\work\p\idot\braboygo\0112640\1368	908-shr-deta1s.DGN	DRAWN -	REVISED -			I-80	**	BUREAU	344	15	
	PLOT SCALE = 50.7353' / IN.	CHECKED -	REVISED -			SCALE: _____ SHEET NO. ___ OF ___ SHEETS STA. _____ TO STA. _____					
	PLOT DATE = Sep 07, 2009 - 02:16:44 PM	DATE -	REVISED -			ILLINOIS FED. AID PROJECT 66908					

STAGE CONSTRUCTION ITEMS												
LOCATION	LENGTH	TEMPORARY CONCRETE BARRIER FOOT	RELOCATE TEMP CONC BARRIER FOOT	TEMP MODULAR GLARE SCREENS(6) FOOT	TEMPORARY SPBGR, TA FOOT	TBT, T1 (SPECIAL) TANGENT EACH	HMA(3) SURF REM 8" SQ YD	HMA (3) SHOULDERS 8" SQ YD	WORK ZONE PVT MK REMOVAL(4) SQ FT	PAVEMENT MARKING REMOVAL(5) FOOT	WET TEMP PVT MK TAPE, TYPE III-4"	
											WHITE FOOT	YELLOW FOOT
STA												
<b>STAGE I</b>												
WBL												
1408+60 TO 282+00*	41421								13807		41421.0	
1408+60 TO 1802+25	39365								12122			36365.0
1415+00 TO 1802+25	48406**									48406.0		
EBL												
1366+00 TO 1802+25	43625								29083		43625.0	43625.0
1435+80 TO 1438+30	250				250							
1411+00 TO 1802+25	39125									39125.0		
1438+30 TO 1438+80	50											
1615+50 TO 1618+00	250				250							
1618+00 TO 1618+50	50											
1763+80 TO 1766+30	250				250							
1766+30 TO 1766+80	50											
<b>STAGE II</b>												
EBL												
1366+00 TO 1802+19	43619								14540		43619.0	
1406+35 TO 1802+19	39584								13195			39584.0
WBL												
1408+55 TO 1801+70	39315								13105		39315.0	
1408+55 TO 288+62*	42028								14009			42028.0
1430+80 TO 1431+30	50											
1431+30 TO 1433+80	250				250							
1609+25 TO 1609+75	50											
1609+75 TO 1612+25	250				250							
1754+50 TO 1755+00	50											
1755+00 TO 1757+50	250				250							
<b>STAGE I</b>												
1408+60 TO 1804+25	39565	39565.0		39565								
<b>STAGE II</b>												
1406+55 TO 1802+19	39364		39364									
EBL ON 10' SHLD (FOR STAGE I TRAFFIC)												
1411+00 TO 1802+23(2)	37195						16960	16960				
WBL ON 10' SHLD (FOR STAGE II TRAFFIC)												
1408+55 TO 1801+70(1)	34865						15495	15495				
<b>TOTALS</b>		<b>39565.0</b>	<b>39364.0</b>	<b>39565.0</b>	<b>1500.0</b>	<b>6.0</b>	<b>32455.0</b>	<b>32455.0</b>	<b>96054</b>	<b>87531.0</b>	<b>167980.0</b>	<b>161602.0</b>

\*STA E0 - 1815+21.84(BK) = 275+00(AH)  
\*\*OVERALL LENGTH INCLUDES LENGTH TO REMOVE EXISTING CENTERLINE PVT MK  
(1) LENGTH HERE = ACTUAL LENGTH - LENGTH OF AREAS WHERE THERE WILL BE NEW SHOULDERS NEAR STRUCTURES=4450 LN FT.NO BIT SHOULDER NEEDED FOR NEWLY CONSTRUCTED AREAS NEAR BRIDGES  
(2)LENGTH HERE = ACTUAL LENGTH - LENGTH OF ALL STRUCTURES = 965'  
(3)TO BE PERFORMED PRIOR TO STAGE I CONSTRUCTION  
(4) MK ZONE PVT MK REMOVAL IS TO REMOVE THE WET WATHER TAPE PLACED AFTER STAGE I AND STAGE II CONSTRUCTION  
(5) PAVEMENT MARKING REMOVAL IS TO REMOVE EXISTING PAVEMENT MARKINGS PRIOR TO STAGE I AND STAGE II CONSTRUCTION  
(6) GLARE SCREENS TO BE USEFD DURING STAGE I AND STAGE II CONSTRUCTION-RELOCATION OF GLARE SCREENS INCLUDED IN COST OF RELOCATE TEMP CONC BARRIER  
USE A 24" HEIGHT FOR GLARE SCREENS, SPACED AT 22" CENTERS. MAX. INSTALLATION ANGLE IS 70 DEGREES.

SURFACE REMOVAL-PCC AND HMA				
LOCATION	LENGTH	HMA SURF REM VAR. DEPTH*	PCC SURF REM- BJ	HMA SURF REM- BJ
	FT	SQ YD	SQ YD	SQ YD
<b>EASTBOUND</b>				
1404+94 TO 1405+64	60.0			267.0
1449+50 TO 1453+52 (SN 006-0127)	400.0	1778.0		
1528+50 TO 1532+50 (SN 006-0132)	400.0	1778.0		
1671+26 TO 1675+26 (SN 006-0129)	400.0	1778.0		
1736+38 TO 1740+38 (SN 006-0133)	400.0	1778.0		
1803+19 TO 1803+89	60.0			267.0
<b>WESTBOUND</b>				
1404+94 TO 1405+64	60.0			267.0
1449+50 TO 1453+52 (SN 006-0127)	400.0	1778.0		
1671+26 TO 1675+26 (SN 006-0129)	400.0	1778.0		
1803+19 TO 1803+79	60.0			267.0
<b>MEDIAN</b>				
WEST X-OVER			1260.0	
EAST X-OVER			1260.0	
<b>GRAND TOTAL</b>		<b>10668.0</b>	<b>2520.0</b>	<b>1068.0</b>

\* UNDER STRUCTURES TO MAINTAIN MINIMUM 16' VERTICAL CLEARANCE

BARRIER WALL MKS SCHEDULE	
LOCATION	BARRIER WALL MARKERS
STA TO STA	EACH
SN 006-0170 AND 006 0171	18
SN 006-0172 AND 006 0173	8
SN 006-0174 AND 006 0175	6
<b>TOTAL</b>	<b>32</b>

FILE NAME =	USER NAME = braboypc	DESIGNED -	REVISED -	<b>STATE OF ILLINOIS DEPARTMENT OF TRANSPORTATION</b>	<b>SCHEDULE OF QUANTITIES</b>	F.A.I. RTE.	SECTION	COUNTY	TOTAL SHEETS	SHEET NO.
ct:\pwr\work\pwr\dot\braboypc\d0112648\d368908-shd-deta1.s.dgn	DRAWN -	REVISED -	I-80			**	BUREAU	344	16	
PLOT SCALE = 50.7353' / IN.	CHECKED -	REVISED -								
PLOT DATE = Sep 07, 2009 - 02:16:37 PM	DATE -	REVISED -	SCALE: _____			SHEET NO. ___ OF ___ SHEETS	STA. _____ TO STA. _____	ILLINOIS FED. AID PROJECT		



**CLASS B PATCHING 17" SCHEDULE  
I-80**

LOCATION (MILE MARKERS)*	DIRECTION (WB/EB)	LENGTH	CL B PATCH TY II SQ YD		CL B PATCH TY III SQ YD		CL B PATCH TY IV SQ YD		DOWEL BARS EACH	SAW CUTS FOOT	PAVEMENT FABRIC SQ YD	TIE BARS EACH PL
			PL	DL	PL	DL	PL	DL				
68.92	EB	6		8					20	48		
68.50	WB	20					27		20	76	27	20
68.22	EB	6	8						20	48		
68.05	WB	6		8					20	48		
67.90	EB	12			16				20	60		
67.60	WB	8		11					20	52		
67.61	EB	8		11					20	52		
67.30	WB	12				16			20	60		
67.30	EB	8	11						20	52		
67.05	WB	8		11					20	52		
67.04	EB	8	11						20	52		
67.03	WB	12			16				20	60		
67.02	EB	8		11					20	52		
66.95	WB	8	11						20	52		
66.90	EB	20					27		20	76	27	20
66.88	WB	8	11						20	52		
66.81	EB	8	11						20	52		
66.70	WB	8	11						20	52		
<b>SUBTOTALS</b>		146	74	109	32	16	27	27	360	996	54	40
<b>TOTALS</b>		146		183		48		54	360	996	54	40

\* CONTINGENCY QUANTITY-ACTUAL LOCATIONS WILL VARY

DICH CHECK SCHEDULE	
LOCATION	TEMP DITCH CHECKS
STA TO STA	EACH
SN 006-0024 AND 006 0025	8
SN 006-0026 AND 006 0027	8
SN 006-0028 AND 006 0029	8
SN 006-0030 AND 006 0031	8
<b>TOTAL</b>	<b>32</b>

LOCATIONS ARE IN DITCHLINE AT EARTHWORK  
AREAS. EXACT LOCATIONS TO BE DETERMINED BY ENGINEER

**WOVEN WIRE FENCE SCHEDULE**

LOCATION (APPROXIMATE LOCATIONS)	WB EB	WOVEN WIRE FENCE 4'	WOVEN WIRE FENCE REMOVAL
MILE MARKER		FT	FT
63.3	EB	100	100
63.9(BEHIND GUARDRAIL)	EB	75	75
64.0 TO 64.2	WB	1000	1000
64.3 TO 64.8	WB	2500	2500
65.3 TO 65.6	WB	1500	1500
65.7 TO 65.9	WB	1000	1000
69.2 TO 69.5	EB	1500	1500
I-80 EXIT RAMP TO IL 89(BY MOTEL)	EB	200	200
<b>TOTAL</b>		<b>7875</b>	<b>7875</b>

**TREE REMOVAL SCHEDULE**

STATION	APPROXIMATE NUMBER OF TREES	AVERAGE DIA 15 UNIT AND UNDER DIA	AVERAGE DIA OVER 15 UNIT DIA	TREE REMOVAL (6-15 UNIT DIA) UNITS	TREE REMOVAL (OVER 15 UNIT DIA) UNITS
SN 006-0024 AND 006-0025	50	12	20	576	40.00
SN 006-0026 AND 006-0027	30	12	20	336	40.00
SN 006-0028 AND 006-0029	50	12	20	576	40.00
SN 006-0030 AND 006-0031	40	12	20	456	40.00
<b>TOTAL</b>				<b>1944.00</b>	<b>160.00</b>

LOCATION OF TREES ARE IN BRIDGE REMOVAL AREAS NECESSARY FOR THE CONSTRUCTION OF NEW BRIDGES, EMBANKMENT AND ROADS.  
NUMBER OF TREES IS APPROXIMATE. ENGINEER IS THE SOLE JUDGE ON WHICH TREES WILL BE REMOVED

**EMERGENCY TURNOUT QUANTITIES**

LOCATION	AGG SURF CSE, TYPE B, 12" SQ YD	EARTH EXCAVATION* CU YD
<b>STAGE I EB TRAFFIC</b>		
1538+00	187.0	62.0
1680+00	187.0	62.0
<b>STAGE I WB TRAFFIC</b>		
1538+00	113.0	38.0
1680+00	113.0	38.0
<b>STAGE II EB TRAFFIC</b>		
1538+00	113.0	38.0
1680+00	113.0	38.0
<b>STAGE II WB TRAFFIC</b>		
1538+00	187.0	62.0
1680+00	187.0	62.0
<b>GRAND TOTAL</b>	<b>1200.0</b>	<b>362.0</b>

USE EXCESS EXCAVATION UNDER PROPOSED AGG SURF CSE IF NEEDED

PAVEMENT MARKING QUANTITIES

LOCATION DESCRIPTION	ALIGNMENT	FROM		TO		THPL PVT MK LINE 4 (FOOT)	PREF PL PM TB LINE 6 (FOOT)	POLYUREA PM T1 LN 4 (FOOT)	POLYUREA PM T1 LN 6 (FOOT)	PAVT MRKING GRVING (FOOT)	RAISED REFL PAVT MKR (EACH)	RAISED REF PVT MKR BR (EACH)
		STATION	OFFSET	STATION	OFFSET							
I-80 WB - INSIDE EDGE LINE	I-80	3279+75.0	32.0 LT	3283+93.3	32.0 LT	418						
I-80 WB - CENTER LINE	I-80	3279+75.0	44.0 LT	3283+88.9	44.0 LT		103				12	
I-80 WB - OUTSIDE EDGE LINE	I-80	3279+75.0	56.0 LT	3283+84.4	56.0 LT	409						
I-80 WB - INSIDE EDGE LINE (BRIDGE)	I-80	3283+93.3	32.0 LT	3286+25.8	32.0 LT			232		232		
I-80 WB - CENTER LINE (BRIDGE)	I-80	3283+88.9	44.0 LT	3286+21.5	44.0 LT				58	58		6
I-80 WB - OUTSIDE EDGE LINE (BRIDGE)	I-80	3283+84.4	56.0 LT	3286+17.1	56.0 LT			232		232		
I-80 WB - INSIDE EDGE LINE	I-80	3286+25.8	32.0 LT	3292+50.0	32.0 LT	624						
I-80 WB - CENTER LINE	I-80	3286+21.5	44.0 LT	3292+50.0	44.0 LT		157				16	
I-80 WB - OUTSIDE EDGE LINE	I-80	3286+17.1	56.0 LT	3292+50.0	56.0 LT	632						
I-80 EB - INSIDE EDGE LINE	I-80	3279+75.0	32.0 RT	3284+17.0	32.0 RT	442						
I-80 EB - CENTER LINE	I-80	3279+75.0	44.0 RT	3284+24.4	44.0 RT		112				12	
I-80 EB - OUTSIDE EDGE LINE	I-80	3279+75.0	56.0 RT	3284+25.8	56.0 RT	451						
I-80 EB - INSIDE EDGE LINE (BRIDGE)	I-80	3284+17.0	32.0 RT	3286+48.9	32.0 RT			232		232		
I-80 EB - CENTER LINE (BRIDGE)	I-80	3284+24.4	44.0 RT	3286+53.2	44.0 RT				58	58		6
I-80 EB - OUTSIDE EDGE LINE (BRIDGE)	I-80	3284+25.8	56.0 RT	3286+57.5	56.0 RT			232		232		
I-80 EB - INSIDE EDGE LINE	I-80	3286+48.9	32.0 RT	3292+50.0	32.0 RT	602						
I-80 EB - CENTER LINE	I-80	3286+53.2	44.0 RT	3292+50.0	44.0 RT		149				16	
I-80 EB - OUTSIDE EDGE LINE	I-80	3286+57.5	56.0 RT	3292+50.0	56.0 RT	594						
TOTALS						4171	521	929	116	1045	56	12

GUARDRAIL REMOVAL

LOCATION DESCRIPTION	ALIGNMENT	FROM		TO		GUARDRAIL REM (FOOT)
		STATION	OFFSET	STATION	OFFSET	
I-80 WB - OUTSIDE SHOULDER	I-80	3281+44.7	67.4 LT	3283+83.0	59.6 LT	238
I-80 WB - OUTSIDE OVER BRIDGE	I-80	3283+83.0	59.6 LT	3286+16.0	59.3 LT	232
I-80 WB - OUTSIDE SHOULDER	I-80	3286+16.0	59.3 LT	3289+68.2	74.7 LT	352
I-80 WB - INSIDE SHOULDER	I-80	3283+79.3	29.1 LT	3283+15.0	29.4 LT	15
I-80 WB - INSIDE OVER BRIDGE	I-80	3283+15.0	29.4 LT	3286+26.9	29.0 LT	232
I-80 WB - INSIDE SHOULDER	I-80	3286+26.9	29.0 LT	3287+74.2	6.3 RT	180
I-80 EB - OUTSIDE SHOULDER	I-80	3279+89.1	72.1 RT	3284+26.8	58.7 RT	439
I-80 EB - OUTSIDE OVER BRIDGE	I-80	3284+26.8	58.7 RT	3286+58.7	59.3 RT	232
I-80 EB - OUTSIDE SHOULDER	I-80	3286+58.7	59.3 RT	3292+45.8	67.9 RT	588
I-80 EB - INSIDE SHOULDER	I-80	3282+68.3	5.4 RT	3284+15.8	28.7 RT	181
I-80 EB - INSIDE OVER BRIDGE	I-80	3284+15.8	28.7 RT	3286+47.7	28.7 RT	232
I-80 EB - INSIDE SHOULDER	I-80	3286+47.7	28.7 RT	3286+61.8	28.6 RT	14
TOTAL						2936

REMOVAL OF GUARDRAIL ON BRIDGE WILL BE PAID FOR AS GUARDRAIL REMOVAL

PAVEMENT REMOVAL

LOCATION DESCRIPTION	ALIGNMENT	OFFSET DIRECTION	TO	PAVEMENT REMOVAL (SQ YD)
I-80 EB - APPROACH PAVEMENT	I-80	RT	SN 006-0172	375
I-80 WB - APPROACH PAVEMENT	I-80	LT	SN 006-0173	375
TOTAL				750

PROPOSED HOT-MIX ASPHALT PAVEMENTS

LOCATION DESCRIPTION	ALIGNMENT	OFFSET DIRECTION	FROM	TO	POLY HMA SURF CSE "D" N105 1 1/4" (TON)	POLY LEV BIND N90 3/4" MIN. VAR DEPTH (TON)	POLY BIT MAT (PRIME COAT) (TON)	AGGREGATE (PRIME COAT) (TON)	HMA SURF CSE "C" N50 1 1/4" (TON)	BIT MAT (PRIME COAT) (TON)
I-80 WB - MAINLINE RESURFACING	I-80	LT	3279+75.00	3283+88.83	108	55	0.9	4		
I-80 EB - MAINLINE RESURFACING	I-80	RT	3279+75.00	3284+21.53	117	93	1.0	5		
I-80 WB - MAINLINE RESURFACING	I-80	LT	3286+21.47	3292+50.00	164	143	1.3	7		
I-80 EB - MAINLINE RESURFACING	I-80	RT	3286+53.19	3292+50.00	156	130	1.3	7		
I-80 WB - OUTSIDE SHOULDER	I-80	LT	3279+75.00	3283+84.40					37	0.1
I-80 WB - INSIDE SHOULDER	I-80	LT	3279+75.00	3283+94.50	16					
I-80 EB - OUTSIDE SHOULDER	I-80	RT	3279+75.00	3284+16.99					39	0.2
I-80 EB - INSIDE SHOULDER	I-80	RT	3279+75.00	3284+26.84	20					
I-80 WB - OUTSIDE SHOULDER	I-80	LT	3286+16.30	3292+50.00					58	0.2
I-80 WB - INSIDE SHOULDER	I-80	LT	3286+25.80	3292+50.00	28					
I-80 EB - OUTSIDE SHOULDER	I-80	RT	3286+47.90	3292+50.00					56	0.2
I-80 EB - INSIDE SHOULDER	I-80	RT	3286+47.90	3292+50.00	25					
TOTAL:					634	422	4.4	22	189	1.0

AGGREGATE SHOULDERS, TYPE B

LOCATION DESCRIPTION	ALIGNMENT	OFFSET DIRECTION	FROM	TO	AGGREGATE SHLDS B (TON)
I-80 WB - OUTSIDE SHOULDER	I-80	LT	3279+75.00	3284+14.85	26
I-80 WB - INSIDE SHOULDER	I-80	LT	3279+75.00	3283+53.40	87
I-80 WB - INSIDE SHOULDER	I-80	LT	3285+94.43	3292+50.00	34
I-80 EB - INSIDE SHOULDER	I-80	RT	3286+15.71	3292+50.00	102
TOTALS					249

QUANTITIES ARE BASED ON A AVERAGE AREA DERIVED FROM THE PLAN CROSS SECTIONS THEN MULTIPLIED BY THE LENGTH OF AGGREGATE SHOULDER FROM STATION TO STATION

HOT-MIX ASPHALT SHOULDERS, 12"

LOCATION DESCRIPTION	ALIGNMENT	OFFSET DIRECTION	FROM	TO	FULL DEPTH HMA SHLD 12" (SQ YD)
I-80 WB - OUTSIDE SHOULDER	I-80	LT	3281+71.60	3283+80.70	80
I-80 WB - INSIDE SHOULDER	I-80	LT	3279+75.00	3283+95.50	117
I-80 EB - OUTSIDE SHOULDER	I-80	RT	3281+86.80	3284+14.78	108
I-80 EB - INSIDE SHOULDER	I-80	RT	3279+75.00	3284+14.78	85
I-80 WB - OUTSIDE SHOULDER	I-80	LT	3286+13.53	3288+32.50	109
I-80 WB - INSIDE SHOULDER	I-80	LT	3286+28.00	3292+50.00	130
I-80 EB - OUTSIDE SHOULDER	I-80	RT	3286+61.10	3288+48.10	87
I-80 EB - INSIDE SHOULDER	I-80	RT	3286+46.70	3292+50.00	151
TOTAL					868

HOT-MIX ASPHALT SHOULDERS, 6"

LOCATION DESCRIPTION	ALIGNMENT	OFFSET DIRECTION	FROM	TO	HMA SHLD 6" (SQ YD)
I-80 WB - OUTSIDE G-RAIL STAB.	I-80	LT	3281+25.10	3283+96.00	90
I-80 WB - INSIDE G-RAIL STAB.	I-80	LT	3283+53.40	3284+11.40	19
I-80 EB - OUTSIDE G-RAIL STAB.	I-80	RT	3279+64.10	3284+30.00	206
I-80 EB - INSIDE G-RAIL STAB.	I-80	RT	3279+30.00	3284+45.30	190
I-80 WB - OUTSIDE G-RAIL STAB.	I-80	LT	3285+97.60	3293+40.90	281
I-80 WB - INSIDE G-RAIL STAB.	I-80	LT	3286+12.80	3290+66.70	185
I-80 EB - OUTSIDE G-RAIL STAB.	I-80	RT	3286+31.00	3286+88.90	203
I-80 EB - INSIDE G-RAIL STAB.	I-80	RT	3286+46.10	3292+52.70	19
TOTAL					1194

AGGREGATE BASE COURSE, TYPE A 6"

LOCATION DESCRIPTION	ALIGNMENT	OFFSET DIRECTION	FROM	TO	AGGREGATE BASE CSE TYPE A 6" (SQ YD)
I-80 WB - OUTSIDE SHOULDER	I-80	LT	3281+71.70	3283+80.70	91
I-80 WB - INSIDE SHOULDER	I-80	LT	3279+75.00	3283+95.50	140
I-80 EB - OUTSIDE SHOULDER	I-80	RT	3281+86.80	3284+14.78	121
I-80 EB - INSIDE SHOULDER	I-80	RT	3279+75.00	3284+14.78	110
I-80 WB - OUTSIDE SHOULDER	I-80	LT	3286+13.53	3288+32.50	121
I-80 WB - INSIDE SHOULDER	I-80	LT	3286+28.00	3292+50.00	165
I-80 EB - OUTSIDE SHOULDER	I-80	RT	3286+61.10	3288+48.10	97
I-80 EB - INSIDE SHOULDER	I-80	RT	3286+46.70	3292+50.00	185
TOTAL					940

RUMBLE STRIP

LOCATION DESCRIPTION	ALIGNMENT	FROM		TO		RUMBLE STRIP (FOOT)
		STATION	OFFSET	STATION	OFFSET	
I-80 WB - OUTSIDE SHOULDER	I-80	3279+75.00	LT	3283+84.40	LT	409
I-80 WB - INSIDE SHOULDER	I-80	3279+75.00	LT	3283+94.50	LT	418
I-80 EB - OUTSIDE SHOULDER	I-80	3279+75.00	RT	3284+16.99	RT	451
I-80 EB - INSIDE SHOULDER	I-80	3279+75.00	RT	3284+26.84	RT	442
I-80 WB - OUTSIDE SHOULDER	I-80	3286+16.30	LT	3292+50.00	LT	631
I-80 WB - INSIDE SHOULDER	I-80	3286+25.80	LT	3292+50.00	LT	623
I-80 EB - OUTSIDE SHOULDER	I-80	3286+47.90	RT	3292+50.00	RT	593
I-80 EB - INSIDE SHOULDER	I-80	3286+57.53	RT	3292+50.00	RT	602
TOTAL						4169

TYLIN INTERNATIONAL	USER NAME = #USER#	DESIGNED - CAC	REVISED -
	PLOT SCALE = #SCALE#	DRAWN - CAC	REVISED -
	PLOT DATE = 8/14/2009	CHECKED - JDF	REVISED -
		DATE - 08/14/2009	REVISED -

STATE OF ILLINOIS  
DEPARTMENT OF TRANSPORTATION

F.A.I. ROUTE 80 (I-80)  
SCHEDULE OF QUANTITIES - PROPOSED QUANTITIES

F.A.I. RTE. 80	SECTION	COUNTY	TOTAL SHEETS	SHEET NO.
		BUREAU	344	19
FED. ROAD DIST. NO. ILLINOIS FED. AID PROJECT			CONTRACT NO. 66908	

SCALE: NONE SHEET NO. 2 OF 3 SHEETS STA. TO STA.

• 06-(7BR & BR-1,7VB-M, 6BR & 6, 7 RS-1 & I)

GUARDRAIL AND TRAFFIC BARRIER TERMINALS

LOCATION DESCRIPTION	ALIGNMENT	FROM		TO		STEEL PLATE BEAM GR TYPE A (FOOT)	TRAFFIC BARRIER TERMINAL (EACH)	GUARDRAIL MARKERS (EACH)	TERM MRKERS DIRECT APPLIED (EACH)
		STATION	OFFSET	STATION	OFFSET				
I-80 EB - OUTSIDE SHOULDER	I-80	3279+65.6	67.8 RT	3280+15.0	66.0 RT		TYPE 1 *		1
I-80 EB - OUTSIDE SHOULDER	I-80	3280+15.0	66.0 RT	3284+01.7	64.4 RT	387.5		4	
I-80 EB - OUTSIDE SHOULDER	I-80	3284+01.7	64.4 RT	3284+45.4	66.0 RT		TYPE 6		
I-80 EB - INSIDE SHOULDER	I-80	3279+99.7	20.0 RT	3281+50.0	24.0 RT		TYPE 1 *		1
I-80 EB - INSIDE SHOULDER	I-80	3281+50.0	24.0 RT	3283+86.3	24.9 RT	337.5		4	
I-80 EB - INSIDE SHOULDER	I-80	3283+86.3	24.9 RT	3284+30.0	26.0 RT		TYPE 6		
I-80 EB - OUTSIDE SHOULDER	I-80	3286+46.1	66.0 RT	3286+90.2	66.0 RT		TYPE 6		
I-80 EB - OUTSIDE SHOULDER	I-80	3286+90.2	66.0 RT	3293+38.0	66.0 RT	550		6	
I-80 EB - OUTSIDE SHOULDER	I-80	3293+38.0	66.0 RT	3293+52.7	66.8 RT		TYPE 2		
I-80 EB - INSIDE SHOULDER	I-80	3286+31.0	26.0 RT	3286+74.8	24.9 RT		TYPE 6		
I-80 EB - INSIDE SHOULDER	I-80	3286+74.8	24.9 RT	3286+89.0	23.5 RT		TYPE 2		
I-80 WB - INSIDE SHOULDER	I-80	3283+53.4	23.5 LT	3283+95.3	26.0 LT		TYPE 2		
I-80 WB - INSIDE SHOULDER	I-80	3283+95.3	26.0 LT	3284+11.4	26.0 LT		TYPE 6		
I-80 WB - OUTSIDE SHOULDER	I-80	3281+25.1	66.8 LT	3281+38.9	66.0 LT		TYPE 2		
I-80 WB - OUTSIDE SHOULDER	I-80	3281+38.9	66.0 LT	3283+51.8	66.0 LT	212.5		4	
I-80 WB - OUTSIDE SHOULDER	I-80	3283+51.8	66.0 LT	3283+96.0	66.0 LT		TYPE 6		
I-80 WB - INSIDE SHOULDER	I-80	3286+12.7	26.0 LT	3286+53.0	24.9 LT		TYPE 6		
I-80 WB - INSIDE SHOULDER	I-80	3286+53.0	24.9 LT	3289+81.7	24.0 LT	325		4	
I-80 WB - INSIDE SHOULDER	I-80	3289+81.7	24.0 LT	3290+31.1	20.0 LT		TYPE 1 *		1
I-80 WB - OUTSIDE SHOULDER	I-80	3285+97.6	66.0 LT	3286+41.9	66.0 LT		TYPE 6		
I-80 WB - OUTSIDE SHOULDER	I-80	3286+41.90	66.0 LT	3292+54.8	66.0 LT	612.5		6	
I-80 WB - OUTSIDE SHOULDER	I-80	3292+54.76	66.0 LT	3293+05.2	69.0 LT		TYPE 1 *		1
GUARDRAIL TOTAL (FOOT)						2425	-	-	-
* TOTAL TBT, TYPE 1 (SPECIAL) FLARED (EACH)						-	4	-	-
TOTAL TBT, TYPE 2 (EACH)						-	4	-	-
TOTAL TBT, TYPE 6 (EACH)						-	8	-	-
GUARDRAIL MARKERS (EACH)						-	-	28	-
TERMINAL MARKERS (EACH)						-	-	-	4

LANDSCAPING QUANTITIES

LOCATION DESCRIPTION	ALIGNMENT	OFFSET DIRECTION	FROM	TO	SEEDING CLASS 3 (ACRE)	HEAVY DUTY EXCELSIOR BLANKET (SQ YD)	NITROGEN FERT NUTR (POUND)	PHOSPHORUS FERT NUTR (POUND)	POTASSIUM FERT NUTR (POUND)
I-80 - NORTH SIDE OF WESTBOUND	I-80	LT	3279+75.0	3283+79.6	0.50	1553	29	29	29
I-80 - MEDIAN	I-80	-	3279+41.0	3284+13.7	0.50	1561	29	29	29
I-80 - SOUTH SIDE OF EASTBOUND	I-80	RT	3279+11.4	3284+52.2	0.50	2024	38	38	38
I-80 - NORTH SIDE OF WESTBOUND	I-80	LT	3285+95.5	3293+59.4	0.25	889	17	17	17
I-80 - MEDIAN	I-80	-	3286+29.1	3292+50.0	0.50	1945	36	36	36
I-80 - SOUTH SIDE OF EASTBOUND	I-80	RT	3286+62.2	3292+52.7	1.00	3758	70	70	70
TOTALS					3.25	11729	218	218	218

EROSION CONTROL QUANTITIES

LOCATION DESCRIPTION	ALIGNMENT	OFFSET DIRECTION	FROM	TO	TEMP EROS CONTR SEED (POUND)	PERIMETER EROS BAR (FOOT)
I-80 - NORTH SIDE OF WESTBOUND	I-80	LT	3279+75.0	3279+75.0	32	460
I-80 - MEDIAN	I-80	-	3279+41.0	3279+41.0	32	933
I-80 - SOUTH SIDE OF EASTBOUND	I-80	RT	3279+11.4	3279+11.4	42	619
I-80 - NORTH SIDE OF WESTBOUND	I-80	LT	3285+95.5	3285+95.5	18	828
I-80 - MEDIAN	I-80	-	3286+29.1	3286+29.1	40	1278
I-80 - SOUTH SIDE OF EASTBOUND	I-80	RT	3286+62.2	3286+62.2	78	690
TOTALS					242	4808

EARTH EXCAVATION SCHEDULE

DIRECTION OF TRAVEL	STATION TO STATION	EARTH EXCAVATION (CU YD)	REM & DIS OF UNSUITABLE MATERIAL (CU YD)	EARTH EXC. ADJ. FOR SHRINKAGE (CU YD)	EMBANKMENT (CU YD)	EARTHWORK BALANCE - WASTE (+) OR SHORTAGE (-) (CU YD)
EB I-80	STA. 3279+75 TO STA. 3284+17	19.4	482.5	14.6	1338.3	-1323.7
EB I-80	STA. 3286+58 TO STA. 3292+50	36.2	884.3	27.1	2775.6	-2748.5
WB I-80	STA. 3279+75 TO STA. 3283+84	18.2	472.4	13.7	1331.8	-1318.2
WB I-80	STA. 3286+26 TO STA. 3292+50	33.7	386.0	25.3	835.7	-810.4
TOTALS =		107.6	2225.1	80.7	6281.4	-6200.7
TOTALS (ROUNDED TO NEAREST 5 CU YDS) =		110.0	2230.0	N/A	N/A	-6205.0

NOTES:

- STATION LIMITS, EXCAVATION QUANTITIES, AND EMBANKMENT QUANTITIES WERE TAKEN FROM CROSS SECTIONS.
- THE REMOVAL AND DISPOSAL OF UNSUITABLE MATERIAL QUANTITY WAS BASED ON A ASSUMED DEPTH OF 6 INCHES.
- EARTH EXCAVATION ADJUSTED FOR SHRINKAGE = EXCAVATION QUANTITY X (1-SHRINKAGE FACTOR (.25)).
- EARTHWORK BALANCE = EARTHWORK TO BE REMOVED (WASTE (+)) OR EARTHWORK REQUIRED (SHORTAGE (-) : PAID FOR AS FURNISHED EXCAVATION).
- ALL PAY ITEMS HAVE BEEN ROUNDED UP TO THE NEAREST 5 CUBIC YARDS.
- THE TOP FOUR INCHES (4") SHALL BE VEGETATIVE SUSTAINING SOIL AND SHALL BE INCLUDED IN THE COST OF FURNISHED EXCAVATION.

TYLIN INTERNATIONAL	USER NAME = #USER#	DESIGNED - CAC	REVISED -	STATE OF ILLINOIS DEPARTMENT OF TRANSPORTATION	F.A.I. ROUTE 80 (I-80) SCHEDULE OF QUANTITIES - PROPOSED QUANTITIES			F.A.I. RTE. 80	SECTION •	COUNTY	TOTAL SHEETS 344	SHEET NO. 23
	PLOT SCALE = #SCALE#	DRAWN - CAC	REVISED -		SCALE: NONE	SHEET NO. 3 OF 3 SHEETS	STA. TO STA.	FED. ROAD DIST. NO.	ILLINOIS FED. AID PROJECT	CONTRACT NO. 66908		
	PLOT DATE = 8/14/2009	CHECKED - JDF	REVISED -		* 06-I7BR & BR-1,7VB-M, 6BR & 6, 7 RS-1 & 11							

PAVEMENT MARKING QUANTITIES

LOCATION DESCRIPTION	ALIGNMENT	FROM		TO		THPL PVT MK LINE 4 (FOOT)	PREF PL PM TB LINE 6 (FOOT)	POLYUREA PM T1 LN 4 (FOOT)	POLYUREA PM T1 LN 6 (FOOT)	PAVT MRKING GRVING (FOOT)	RAISED REFL PAVT MKR (EACH)	RAISED REF PVT MKR BR (EACH)
		STATION	OFFSET	STATION	OFFSET							
I-80 WB - INSIDE EDGE LINE	I-80	3458+00.0	32.0 LT	3461+94.9	32.0 LT	395						
I-80 WB - CENTER LINE	I-80	3458+00.0	44.0 LT	3461+94.9	44.0 LT		99				10	
I-80 WB - OUTSIDE EDGE LINE	I-80	3458+00.0	56.0 LT	3461+94.9	56.0 LT	395						
I-80 WB - INSIDE EDGE LINE (BRUSH CREEK BRIDGE)	I-80	3461+94.9	32.0 LT	3466+11.8	32.0 LT			417		417		
I-80 WB - CENTER LINE (BRUSH CREEK BRIDGE)	I-80	3461+94.9	44.0 LT	3466+11.8	44.0 LT				104	104		12
I-80 WB - OUTSIDE EDGE LINE (BRUSH CREEK BRIDGE)	I-80	3461+94.9	56.0 LT	3466+11.8	56.0 LT			417		417		
I-80 WB - INSIDE EDGE LINE	I-80	3466+11.8	32.0 LT	3469+25.0	32.0 LT	313						
I-80 WB - CENTER LINE	I-80	3466+11.8	44.0 LT	3469+25.0	44.0 LT		78			842	8	
I-80 WB - OUTSIDE EDGE LINE	I-80	3466+11.8	56.0 LT	3469+25.0	56.0 LT	313				93		
I-80 EB - INSIDE EDGE LINE	I-80	3454+00.0	32.0 RT	3462+41.7	32.0 RT			842		842		
I-80 EB - CENTER LINE	I-80	3454+00.0	44.0 RT	3462+41.7	44.0 RT				210	370		22
I-80 EB - OUTSIDE EDGE LINE	I-80	3454+00.0	56.0 RT	3462+41.7	56.0 RT			842		93		
I-80 EB - INSIDE EDGE LINE (BRUSH CREEK BRIDGE)	I-80	3462+41.7	32.0 RT	3466+11.8	32.0 RT			370		370		
I-80 EB - CENTER LINE (BRUSH CREEK BRIDGE)	I-80	3462+41.7	44.0 RT	3466+11.8	44.0 RT				93	463		10
I-80 EB - OUTSIDE EDGE LINE (BRUSH CREEK BRIDGE)	I-80	3462+41.7	56.0 RT	3466+11.8	56.0 RT			370		116		
I-80 EB - INSIDE EDGE LINE	I-80	3466+11.8	32.0 RT	3470+75.0	32.0 RT			463		463		
I-80 EB - CENTER LINE	I-80	3466+11.8	44.0 RT	3470+75.0	44.0 RT				116			12
I-80 EB - OUTSIDE EDGE LINE	I-80	3466+11.8	56.0 RT	3470+75.0	56.0 RT			463				
TOTAL						1416	177	4184	523	4589	18	56

PAVEMENT REMOVAL

LOCATION DESCRIPTION	ALIGNMENT	OFFSET DIRECTION	FROM	TO	PAVEMENT REM (SQ YD)
I-80 EB - MAINLINE FULL-DEPTH	I-80	RT	3454+00.0	3461+00.0	1877
I-80 EB - MAINLINE FULL-DEPTH	I-80	RT	3466+11.8	3470+75.0	1235
TOTAL					3112

GUARDRAIL REMOVAL

LOCATION DESCRIPTION	ALIGNMENT	FROM		TO		GUARDRAIL REMOVAL (FOOT)
		STATION	OFFSET	STATION	OFFSET	
I-80 EB - OUTSIDE SHOULDER	I-80	3456+29.4	68.1 RT	3462+41.7	60.3 RT	613
I-80 EB - OUTSIDE OVER BRIDGE	I-80	3462+41.7	60.3 RT	3466+11.8	59.2 RT	370
I-80 EB - OUTSIDE SHOULDER	I-80	3466+11.8	59.2 RT	3467+52.6	68.5 RT	141
I-80 EB - INSIDE SHOULDER	I-80	3461+18.6	5.9 LT	3462+41.7	26.7 RT	128
I-80 EB - INSIDE OVER BRIDGE	I-80	3462+41.7	26.7 RT	3466+11.8	28.4 RT	370
I-80 EB - INSIDE SHOULDER	I-80	3466+11.8	28.4 RT	3466+27.2	28.3 RT	15
I-80 WB - OUTSIDE OVER BRIDGE	I-80	3462+02.8	59.4 LT	3466+11.8	59.3 LT	409
I-80 WB - OUTSIDE SHOULDER	I-80	3466+11.8	59.3 LT	3469+62.6	72.3 LT	351
I-80 WB - INSIDE OVER BRIDGE	I-80	3462+21.8	28.3 LT	3466+11.8	28.6 LT	390
I-80 WB - INSIDE SHOULDER	I-80	3466+11.8	28.6 LT	3467+38.6	2.6 LT	130
TOTAL						2919

REMOVAL OF GUARDRAIL ON BRIDGE WILL BE PAID FOR AS GUARDRAIL REMOVAL

BRIDGE APPROACH SHOULDER DRAINS

LOCATION DESCRIPTION	ALIGNMENT	OFFSET DIRECTION	PAVEMENT REM (SQ YD)	TYPE E INLET BOX, STD (EACH)	PIPE DRAIN, 12" (FOOT)	CONCRETE THRUST BLOCKS (EACH)	METAL END SECTIONS, 12" (EACH)
I-80 EB - SN 006-0170	I-80	RT	365	2	93	2	2
I-80 WB - SN 006-0171	I-80	LT	365	4	168	4	4
TOTALS			730	6	261	6	6

PAVED SHOULDER REMOVAL

LOCATION DESCRIPTION	ALIGNMENT	OFFSET DIRECTION	FROM	TO	PAVED SHLD REMOVAL (SQ YD)
I-80 EB - INSIDE SHOULDER	I-80	RT	3454+00.0	3461+06.0	318
I-80 EB - OUTSIDE SHOULDER	I-80	RT	3058+20.0	3462+41.7	770
I-80 EB - INSIDE SHOULDER	I-80	RT	3466+11.8	3470+75.0	204
I-80 EB - OUTSIDE SHOULDER	I-80	RT	3466+11.8	3470+75.0	439
TOTAL					1730

TYLIN INTERNATIONAL

USER NAME = #USER#	DESIGNED - CAC	REVISED -
PLOT SCALE = #SCALE#	DRAWN - CAC	REVISED -
PLOT DATE = 8/17/2009	CHECKED - JDF	REVISED -
	DATE - 08/14/2009	REVISED -

STATE OF ILLINOIS  
DEPARTMENT OF TRANSPORTATION

F.A.I. ROUTE 80 (I-80)  
SCHEDULE OF QUANTITIES  
REMOVAL/MISCELLANEOUS QUANTITIES SHEET 1 OF 3

F.A.I. RTE. 80	SECTION *	COUNTY	TOTAL SHEETS NO. 344	SHEET NO. 21
SCALE:		SHEET NO. OF SHEETS	STA. TO STA.	
FED. ROAD DIST. NO.		ILLINOIS FED. AID PROJECT		
CONTRACT NO. 66908				

\* 06-17BR & BR-1,TVB-M, 6BR & 6, 7 RS-1 & 11

PROPOSED PAVEMENT ITEMS

LOCATION DESCRIPTION	ALIGNMENT	OFFSET DIRECTION	FROM	TO	POLY HMA SURF CSE "D" N105 1 1/4" (TON)	POLY LEV BIND N90 3/4" MIN, VAR DEPTH (TON)	POLY BIT MAT (PRIME COAT) (TON)	AGGREGATE (PRIME COAT) (TON)	HMA SURF CSE "C" N50, 1 1/4" (TON)	BIT MAT (PRIME COAT) (TON)	CRC PAVT 10" (SQ YD)	PAVT REINF 10" (SQ YD)
I-80 WB - MAINLINE RESURFACING	I-80	LT	3458+00.0	3461+94.9	103	32	0.8	2				
I-80 WB - MAINLINE RESURFACING	I-80	LT	3466+11.8	3469+25.0	82	46	0.7	2				
I-80 WB - OUTSIDE SHOULDER	I-80	LT	3458+00.0	3461+94.9					43	0.2		
I-80 WB - INSIDE SHOULDER	I-80	LT	3458+00.0	3461+94.9	16							
I-80 WB - OUTSIDE SHOULDER	I-80	LT	3466+11.8	3469+25.0					23	0.1		
I-80 WB - INSIDE SHOULDER	I-80	LT	3466+11.8	3469+25.0	14							
I-80 EB - MAINLINE FULL-DEPTH	I-80	RT	3454+00.0	3462+41.7							2245	2245
I-80 EB - MAINLINE FULL-DEPTH	I-80	RT	3466+11.8	3470+75.0							1235	1235
				TOTAL	215	78	1.5	4	66	0.3	3480	3480

HOT-MIX ASPHALT SHOULDERS, 12"

LOCATION DESCRIPTION	ALIGNMENT	FROM	TO	HMA SHLD 12" (SQ YD)
I-80 WB - INSIDE SHOULDER FULL DEPTH	I-80	3458+00.0	3461+94.9	101
I-80 WB - OUTSIDE SHOULDER FULL DEPTH	I-80	3466+11.8	3469+25.0	115
I-80 WB - INSIDE SHOULDER FULL DEPTH	I-80	3466+11.8	3469+25.0	69
			TOTAL	284

HOT-MIX ASPHALT SHOULDERS, 6"

LOCATION DESCRIPTION	ALIGNMENT	FROM	TO	HMA SHLD 6" (SQ YD)
I-80 EB - GUARDRAIL STABILIZATION	I-80	3457+89.1	3462+56.7	190
I-80 EB - GUARDRAIL STABILIZATION	I-80	3455+39.6	3462+56.7	273
I-80 WB - GUARDRAIL STABILIZATION	I-80	3455+89.0	3462+09.9	207
I-80 WB - GUARDRAIL STABILIZATION	I-80	3461+51.2	3462+09.9	20
I-80 WB - GUARDRAIL STABILIZATION	I-80	3465+96.8	3470+51.1	186
I-80 WB - GUARDRAIL STABILIZATION	I-80	3465+96.8	3470+26.5	177
I-80 EB - GUARDRAIL STABILIZATION	I-80	3465+96.8	3466+55.6	20
I-80 EB - GUARDRAIL STABILIZATION	I-80	3465+96.8	3466+93.2	32
			TOTAL	1105

AGGREGATE SHOULDERS, TYPE B

LOCATION DESCRIPTION	ALIGNMENT	OFFSET DIRECTION	FROM	TO	AGGREGATE SHLDS B (TON)
I-80 WB - OUTSIDE SHOULDER	I-80	LT	3458+00.0	3461+51.2	64
I-80 EB - OUTSIDE SHOULDER	I-80	RT	3454+00.0	3455+44.2	26
I-80 EB - INSIDE SHOULDER	I-80	RT	3454+00.0	3457+93.7	79
I-80 EB - OUTSIDE SHOULDER	I-80	RT	3466+93.2	3470+75.0	69
I-80 EB - INSIDE SHOULDER	I-80	RT	3466+55.6	3470+75.0	67
			TOTAL		304

AGGREGATE SUBGRADE 12"

LOCATION DESCRIPTION	ALIGNMENT	OFFSET DIRECTION	FROM	TO	AGG SUBGRADE 12" (SQ YD)
I-80 EB - MAINLINE FULL-DEPTH	I-80	RT	3454+00.0	3462+41.7	2245
I-80 EB - MAINLINE FULL-DEPTH	I-80	RT	3466+11.8	3470+75.0	1235
I-80 EB - INSIDE SHOULDER	I-80	RT	3454+00.0	3462+41.7	655
I-80 EB - OUTSIDE SHOULDER	I-80	RT	3058+20.0	3462+41.7	1029
I-80 EB - INSIDE SHOULDER	I-80	RT	3466+11.8	3470+75.0	360
I-80 EB - OUTSIDE SHOULDER	I-80	RT	3466+11.8	3470+75.0	566
			TOTAL		6089

STABILIZED SUB-BASE - HOT-MIX ASPHALT, 4"

LOCATION DESCRIPTION	ALIGNMENT	OFFSET DIRECTION	FROM	TO	STABILIZED SUBBASE HMA 4" (SQ YD)
I-80 EB - MAINLINE FULL-DEPTH	I-80	RT	3454+00.0	3462+41.7	2245
I-80 EB - MAINLINE FULL-DEPTH	I-80	RT	3466+11.8	3470+75.0	1235
			TOTAL		3480

SUB-BASE GRANULAR MATERIAL, TYPE C 4"

LOCATION DESCRIPTION	ALIGNMENT	OFFSET DIRECTION	FROM	TO	SUBBASE GRAN MAT TYPE C 4" (SQ YD)
I-80 EB - INSIDE SHOULDER	I-80	RT	3454+00.0	3462+41.7	655
I-80 EB - OUTSIDE SHOULDER	I-80	RT	3058+20.0	3462+41.7	1029
I-80 EB - INSIDE SHOULDER	I-80	RT	3466+11.8	3470+75.0	360
I-80 EB - OUTSIDE SHOULDER	I-80	RT	3466+11.8	3470+75.0	566
			TOTAL		2610

PORTLAND CEMENT CONCRETE SHOULDERS, 10"

LOCATION DESCRIPTION	ALIGNMENT	FROM	TO	PCC SHLD 10" (SQ YD)
I-80 EB - INSIDE SHOULDER	I-80	3454+00.0	3462+41.7	561
I-80 EB - OUTSIDE SHOULDER	I-80	3058+20.0	3462+41.7	935
I-80 EB - INSIDE SHOULDER	I-80	3466+11.8	3470+75.0	309
I-80 EB - OUTSIDE SHOULDER	I-80	3466+11.8	3470+75.0	515
			TOTAL	2320

AGGREGATE BASE COURSE, TYPE A 6"

LOCATION DESCRIPTION	ALIGNMENT	OFFSET DIRECTION	FROM	TO	AGGREGATE BASE CSE TYPE A 6" (SQ YD)
I-80 WB - INSIDE SHOULDER	I-80	LT	3458+00.0	3461+94.9	121
I-80 WB - OUTSIDE SHOULDER	I-80	LT	3466+11.8	3469+25.0	130
I-80 WB - INSIDE SHOULDER	I-80	LT	3466+11.8	3469+25.0	87
			TOTAL		338

TYLIN INTERNATIONAL

USER NAME = *USER*	DESIGNED - CAC	REVISED -
PLOT SCALE = *SCALE*	DRAWN - CAC	REVISED -
PLOT DATE = 8/14/2009	CHECKED - JDF	REVISED -
	DATE - 08/14/2009	REVISED -

STATE OF ILLINOIS  
DEPARTMENT OF TRANSPORTATION

F.A.I. ROUTE 80 (I-80)  
SCHEDULE OF QUANTITIES  
PROPOSED QUANTITIES SHEET 2 OF 3

SCALE:	SHEET NO.	OF SHEETS	STA.	TO STA.	F.A.I. RTE. 80	SECTION *	COUNTY	TOTAL SHEETS	SHEET NO.
							BUREAU	744	22
								CONTRACT NO. 66908	
FED. ROAD DIST. NO. [ILLINOIS] FED. AID PROJECT									
* 06-L7BR & BR-1,7VB-M, 6BR & 6, 7 RS-1 & 11									

**GUARDRAIL AND TRAFFIC BARRIER TERMINALS**

LOCATION DESCRIPTION	ALIGNMENT	FROM		TO		STEEL PLATE BEAM GR TYPE A (FOOT)	TRAFFIC BARRIER TERMINAL (EACH)	GUARDRAIL MARKERS (EACH)	TERM MRKRS DIRECT APPLIED (EACH)
		STATION	OFFSET	STATION	OFFSET				
I-80 EB - OUTSIDE SHOULDER	I-80	3455+75.2	70.3 RT	3456+25.5	66.0 RT		TYPE 1 *		1
I-80 EB - OUTSIDE SHOULDER	I-80	3456+25.5	66.0 RT	3462+13.0	66.0 RT	587.5		6	
I-80 EB - OUTSIDE SHOULDER	I-80	3462+13.0	66.0 RT	3462+56.7	66.0 RT		TYPE 6		
I-80 EB - INSIDE SHOULDER	I-80	3458+24.8	22.2 RT	3458+75.1	24.0 RT		TYPE 1 *		1
I-80 EB - INSIDE SHOULDER	I-80	3458+75.1	24.0 RT	3462+12.6	24.8 RT	337.5		4	
I-80 EB - INSIDE SHOULDER	I-80	3462+12.6	24.8 RT	3462+56.7	26.0 RT		TYPE 6		
I-80 EB - INSIDE SHOULDER	I-80	3465+96.8	26.0 RT	3466+11.8	26.0 RT		TYPE 6		
I-80 EB - INSIDE SHOULDER	I-80	3466+11.8	26.0 RT	3466+41.0	24.8 RT				
I-80 EB - INSIDE SHOULDER	I-80	3466+41.0	24.8 RT	3466+55.6	23.4 RT		TYPE 2		
I-80 EB - OUTSIDE SHOULDER	I-80	3465+96.8	66.0 RT	3466+41.0	66.0 RT		TYPE 6		
I-80 EB - OUTSIDE SHOULDER	I-80	3466+41.0	66.0 RT	3466+78.5	66.0 RT	37.5		4	
I-80 EB - OUTSIDE SHOULDER	I-80	3466+78.5	66.0 RT	3466+93.2	66.9 RT		TYPE 2		
I-80 WB - INSIDE SHOULDER	I-80	3461+51.1	23.3 LT	3461+65.3	24.8 LT		TYPE 2		
I-80 WB - INSIDE SHOULDER	I-80	3071+45.7	26.0 LT	3072+45.7	24.0 LT				
I-80 WB - INSIDE SHOULDER	I-80	3461+65.3	24.8 LT	3462+09.9	26.0 LT		TYPE 6		
I-80 WB - OUTSIDE SHOULDER	I-80	3455+89.0	67.0 LT	3456+03.6	66.2 LT		TYPE 2		
I-80 WB - OUTSIDE SHOULDER	I-80	3456+03.6	66.2 LT	3461+65.7	66.0 LT	562.5		6	
I-80 WB - OUTSIDE SHOULDER	I-80	3461+65.7	66.0 LT	3462+09.9	66.0 LT		TYPE 6		
I-80 WB - INSIDE SHOULDER	I-80	3465+96.8	24.6 LT	3466+41.0	24.8 LT		TYPE 6	4	
I-80 WB - INSIDE SHOULDER	I-80	3466+41.0	24.8 LT	3469+78.5	24.0 LT	337.5			
I-80 WB - INSIDE SHOULDER	I-80	3469+78.5	24.0 LT	3470+28.7	19.73 LT		TYPE 1 *		1
I-80 WB - OUTSIDE SHOULDER	I-80	3465+96.8	66.0 LT	3466+40.6	66.0 LT		TYPE 6	4	
I-80 WB - OUTSIDE SHOULDER	I-80	3466+40.6	66.0 LT	3469+40.6	66.0 LT	300			
I-80 WB - OUTSIDE SHOULDER	I-80	3469+40.6	66.0 LT	3469+90.8	70.3 LT		TYPE 1 *		1
GUARDRAIL TOTAL (FOOT)						2163	-	-	-
* TOTAL TBT, TYPE 1 (SPECIAL) FLARED (EACH)						-	4	-	-
TOTAL TBT, TYPE 2 (EACH)						-	4	-	-
TOTAL TBT, TYPE 6 (EACH)						-	8	-	-
GUARDRAIL MARKERS, TYPE A								28	-
TERMINAL MARKERS, DIRECT APPLIED									4

**WIDE FLANGE BEAM TERMINAL JOINT COMPLETE, 24'**

LOCATION DESCRIPTION	ALIGNMENT	OFFSET DIRECTION	STATION	WIDE FLANGE BEAM TERM COMPLT, 24' (SQ YD)
I-80 EB - WEST PROJECT LIMIT	I-80	RT	3454+00.0	1
I-80 EB - EAST PROJECT LIMIT	I-80	RT	3470+75.0	1
TOTAL				2

**EARTH EXCAVATION SCHEDULE**

DIRECTION OF TRAVEL	STATION TO STATION	EARTH EXCAVATION (CU YD)	REM & DIS OF UNSUITABLE MATERIAL (CU YD)	EARTH EXC. ADJ. FOR SHRINKAGE (CU YD)	EMBANKMENT (CU YD)	EARTHWORK BALANCE - WASTE (+) OR SHORTAGE (-) (CU YD)
EB I-80	STA. 3454+00 TO STA. 3462+72	268.2	1122.3	201.2	4627.9	-4426.8
EB I-80	STA. 3465+82 TO STA. 3470+75	126.9	400.8	95.1	1783.7	-1688.5
WB I-80	STA. 3458+00 TO STA. 3462+25	40.6	475.4	30.4	1171.7	-1141.3
WB I-80	STA. 3465+82 TO STA. 3469+25	53.7	199.3	40.3	315.4	-275.1
TOTALS =		489.3	2197.7	367.0	7898.6	-7531.6
TOTALS (ROUNDED TO NEAREST 5 CU YDS) =		490.0	2200.0	N/A	N/A	-7535.0

**NOTES:**

- STATION LIMITS, EXCAVATION QUANTITIES, AND EMBANKMENT QUANTITIES WERE TAKEN FROM CROSS SECTIONS.
- THE REMOVAL AND DISPOSAL OF UNSUITABLE MATERIAL QUANTITY WAS BASED ON A ASSUMED DEPTH OF 6 INCHES.
- EARTH EXCAVATION ADJUSTED FOR SHRINKAGE = EXCAVATION QUANTITY X (1-SHRINKAGE FACTOR (.25)).
- EARTHWORK BALANCE = EARTHWORK TO BE REMOVED (WASTE (+)) OR EARTHWORK REQUIRED (SHORTAGE (-)); PAID FOR AS FURNISHED EXCAVATION.
- ALL PAY ITEMS HAVE BEEN ROUNDED UP TO THE NEAREST 5 CUBIC YARDS.
- THE TOP FOUR INCHES (4") SHALL BE VEGETATIVE SUSTAINING SOIL AND SHALL BE INCLUDED IN THE COST OF FURNISHED EXCAVATION.

**LANDSCAPING QUANTITIES**

LOCATION DESCRIPTION	ALIGNMENT	OFFSET DIRECTION	FROM	TO	SEEDING CLASS 3 (ACRE)	HEAVY DUTY EXCELSIOR BLANKET (SQ YD)	NITROGEN FERT NUTR (POUND)	PHOSPHORUS FERT NUTR (POUND)	POTASSIUM FERT NUTR (POUND)
I-80 - NORTH SIDE OF WESTBOUND	I-80	LT	3455+89.0	3462+09.9	0.50	1825	34	34	34
I-80 - MEDIAN	I-80	-	3454+00.0	3462+56.7	0.50	2342	44	44	44
I-80 - SOUTH SIDE OF EASTBOUND	I-80	RT	3454+00.0	3462+56.7	1.00	4338	81	81	81
I-80 - NORTH SIDE OF WESTBOUND	I-80	LT	3465+96.8	3470+51.2	0.25	834	15	15	15
I-80 - MEDIAN	I-80	-	3465+96.8	3470+75.0	0.50	1230	23	23	23
I-80 - SOUTH SIDE OF EASTBOUND	I-80	RT	3465+96.8	3470+75.0	0.25	1103	21	21	21
TOTAL					3.00	11672	217	217	217

**EROSION CONTROL QUANTITIES**

LOCATION DESCRIPTION	ALIGNMENT	OFFSET DIRECTION	FROM	TO	TEMP EROS CONTR SEED (POUND)	PERIMETER EROS BAR (FOOT)
I-80 - NORTH SIDE OF WESTBOUND	I-80	LT	3455+89.0	3462+09.9	38	650
I-80 - MEDIAN	I-80	-	3454+00.0	3462+56.7	48	1260
I-80 - SOUTH SIDE OF EASTBOUND	I-80	RT	3454+00.0	3462+56.7	90	869
I-80 - NORTH SIDE OF WESTBOUND	I-80	LT	3465+96.8	3470+51.2	17	465
I-80 - MEDIAN	I-80	-	3465+96.8	3470+75.0	25	963
I-80 - SOUTH SIDE OF EASTBOUND	I-80	RT	3465+96.8	3470+75.0	23	487
TOTAL					241	4695

**RUMBLE STRIP**

LOCATION DESCRIPTION	ALIGNMENT	FROM		TO		RUMBLE STRIP (FOOT)
		STATION	OFFSET	STATION	OFFSET	
I-80 WB - OUTSIDE SHOULDER	I-80	3458+00.0	57.7 LT	3461+94.9	57.7 LT	395
I-80 WB - INSIDE SHOULDER	I-80	3458+00.0	30.3 LT	3461+94.9	30.3 LT	395
I-80 EB - INSIDE SHOULDER	I-80	3454+00.0	30.5 RT	3462+41.7	30.5 RT	840
I-80 EB - OUTSIDE SHOULDER	I-80	3454+00.0	57.5 RT	3462+41.7	57.5 RT	840
I-80 WB - OUTSIDE SHOULDER	I-80	3466+11.8	57.7 LT	3469+25.0	57.7 LT	314
I-80 WB - INSIDE SHOULDER	I-80	3466+11.8	30.3 LT	3469+25.0	30.3 LT	314
I-80 EB - INSIDE SHOULDER	I-80	3466+11.8	30.3 RT	3470+75.0	30.3 RT	465
I-80 EB - OUTSIDE SHOULDER	I-80	3466+11.8	57.7 RT	3470+75.0	57.7 RT	465
TOTAL						4028

**TYLIN INTERNATIONAL**

USER NAME = *USER*	DESIGNED - CAC	REVISED -
PLOT SCALE = *SCALE*	DRAWN - CAC	REVISED -
PLOT DATE = 8/14/2009	CHECKED - JDF	REVISED -
	DATE - 08/14/2009	REVISED -

**STATE OF ILLINOIS  
DEPARTMENT OF TRANSPORTATION**

**F.A.I. ROUTE 80 (I-80)  
SCHEDULE OF QUANTITIES  
PROPOSED / MISCELLANEOUS QUANTITIES SHEET 3 OF 3**

F.A.I. RTE. 80	SECTION	COUNTY	TOTAL SHEETS	SHEET NO.
		BUREAU	344	23
CONTRACT NO. 66908				

SCALE: SHEET NO. OF SHEETS STA. TO STA.

FED. ROAD DIST. NO. ILLINOIS FED. AID PROJECT  
\* 06-17BR & BR-1,7VB-M, GBR & 6, 7 RS-1 & I1

PAVEMENT MARKING QUANTITIES

LOCATION DESCRIPTION	ALIGNMENT	FROM		TO		THPL PVT MK LINE 4 (FOOT)	PREF PL PM TB LINE 6 (FOOT)	POLYUREA PM T1 LN 4 (FOOT)	POLYUREA PM T1 LN 6 (FOOT)	PAVT MKING GRVING (FOOT)	RAISED REFL PAVT MKR (EACH)	RAISED REF PVT MKR BR (EACH)
		STATION	OFFSET	STATION	OFFSET							
I-80 WB - OUTSIDE EDGE LINE	I-80	3603+00.0	56' LT	3607+65.4	56' LT	463						
I-80 WB - CENTER LINE	I-80	3603+00.0	44' LT	3607+65.7	44' LT		116				12	
I-80 WB - INSIDE EDGE LINE	I-80	3603+00.0	32' LT	3607+65.8	32' LT	465						
I-80 EB - OUTSIDE EDGE LINE	I-80	3603+00.0	56' RT	3607+67.4	56' RT	469						
I-80 EB - CENTER LINE	I-80	3603+00.0	44' RT	3607+67.3	44' RT		117				12	
I-80 EB - INSIDE EDGE LINE	I-80	3603+00.0	32' RT	3607+67.0	32' RT	468						
I-80 WB - OUTSIDE EDGE LINE (BRIDGE)	I-80	3607+65.4	56' LT	3610+47.3	56' LT			281		281		
I-80 WB - CENTER LINE (BRIDGE)	I-80	3607+65.7	44' LT	3610+47.1	44' LT				70	70		8
I-80 WB - INSIDE EDGE LINE (BRIDGE)	I-80	3607+65.8	32' LT	3610+47.2	32' LT			281		281		
I-80 EB - OUTSIDE EDGE LINE (BRIDGE)	I-80	3607+67.4	56' RT	3610+46.4	56' RT			281		281		
I-80 EB - CENTER LINE (BRIDGE)	I-80	3607+67.3	44' RT	3610+46.4	44' RT				70	70		8
I-80 EB - INSIDE EDGE LINE (BRIDGE)	I-80	3607+67.0	32' RT	3610+46.6	32' RT			281		281		
I-80 WB - OUTSIDE EDGE LINE	I-80	3610+47.3	56' LT	3611+25.4	56' LT	78						
I-80 WB - CENTER LINE	I-80	3610+47.1	44' LT	3611+24.0	44' LT		19				2	
I-80 WB - INSIDE EDGE LINE	I-80	3610+47.2	32' LT	3611+22.5	32' LT	75						
I-80 EB - OUTSIDE EDGE LINE	I-80	3610+46.4	56' RT	3611+11.7	56' RT	66						
I-80 EB - CENTER LINE	I-80	3610+46.4	44' RT	3611+13.0	44' RT		17				2	
I-80 EB - INSIDE EDGE LINE	I-80	3610+46.6	32' RT	3611+14.4	32' RT	68						
I-80 WB - OUTSIDE EDGE LINE (RECONSTRUCTION)	I-80	3611+25.4	56' LT	3614+66.4	56' LT	340						
I-80 WB - CENTER LINE (RECONSTRUCTION)	I-80	3611+24.0	44' LT	3614+64.5	44' LT		85				10	
I-80 WB - INSIDE EDGE LINE (RECONSTRUCTION)	I-80	3611+22.5	32' LT	3614+62.6	32' LT	339						
I-80 EB - OUTSIDE EDGE LINE (RECONSTRUCTION)	I-80	3611+11.7	56' RT	3614+48.9	56' RT	339						
I-80 EB - CENTER LINE (RECONSTRUCTION)	I-80	3611+13.0	44' RT	3614+50.8	44' RT		85				10	
I-80 EB - INSIDE EDGE LINE (RECONSTRUCTION)	I-80	3611+14.4	32' RT	3614+52.6	32' RT	339						
I-80 WB - OUTSIDE EDGE LINE	I-80	3614+66.4	56' LT	3619+00.0	56' LT	431						
I-80 WB - CENTER LINE	I-80	3614+64.5	44' LT	3619+00.0	44' LT		108				12	
I-80 WB - INSIDE EDGE LINE	I-80	3614+62.6	32' LT	3619+00.0	32' LT	436						
I-80 EB - OUTSIDE EDGE LINE	I-80	3614+48.9	56' RT	3619+00.0	56' RT	454						
I-80 EB - CENTER LINE	I-80	3614+50.8	44' RT	3619+00.0	44' RT		113				12	
I-80 EB - INSIDE EDGE LINE	I-80	3614+52.6	32' RT	3619+00.0	32' RT	449						
TOTAL						5278	660	1122	140	1262	72	16

BRIDGE APPROACH SHOULDER DRAINS

LOCATION DESCRIPTION	ALIGNMENT	OFFSET DIRECTION	PAVEMENT REM (SQ YD)	TYPE E INLET BOX, STD (EACH)	PIPE DRAIN, 12" (FOOT)	CONCRETE THRUST BLOCKS (EACH)	METAL END SECTIONS, 12" (EACH)
I-80 EB - SN 006-0173	I-80	RT	338	1	13	1	1
I-80 WB - SN 006-0174	I-80	LT	338	1	75	1	1
TOTALS			676	2	88	2	2

GUARDRAIL REMOVAL

LOCATION DESCRIPTION	ALIGNMENT	FROM		TO		GUARDRAIL REMOVAL (FOOT)
		STATION	OFFSET	STATION	OFFSET	
I-80 WB - OUTSIDE SHOULDER	I-80	3605+70.2	LT	3607+49.2	LT	178
I-80 WB - OUTSIDE OVER BRIDGE	I-80	3607+49.2	LT	3610+65.1	LT	314
I-80 WB - OUTSIDE SHOULDER	I-80	3610+65.1	LT	3610+25.8	LT	60
I-80 WB - OUTSIDE OVER BRIDGE	I-80	3610+25.8	LT	3614+67.1	LT	340
I-80 WB - OUTSIDE SHOULDER	I-80	3614+67.1	LT	3619+14.6	LT	445
I-80 EB - OUTSIDE SHOULDER	I-80	3601+53.6	RT	3607+52.4	RT	603
I-80 EB - OUTSIDE OVER BRIDGE	I-80	3607+52.4	RT	3610+64.4	RT	314
I-80 EB - OUTSIDE SHOULDER	I-80	3610+64.4	RT	3611+11.4	RT	47
I-80 EB - OUTSIDE OVER BRIDGE	I-80	3611+11.4	RT	3614+48.5	RT	339
I-80 EB - OUTSIDE SHOULDER	I-80	3614+48.5	RT	3616+25.7	RT	179
I-80 WB - INSIDE OVER BRIDGE	I-80	3607+70.0	LT	3610+65.0	LT	294
I-80 WB - INSIDE SHOULDER	I-80	3610+65.0	LT	3611+22.1	LT	57
I-80 WB - INSIDE OVER BRIDGE	I-80	3611+22.1	LT	3614+61.5	LT	339
I-80 WB - INSIDE SHOULDER	I-80	3614+61.5	LT	3615+82.6	RT	153
I-80 EB - INSIDE SHOULDER	I-80	3606+42.7	LT	3607+50.8	RT	142
I-80 EB - INSIDE OVER BRIDGE	I-80	3607+50.8	RT	3610+65.0	RT	315
I-80 EB - INSIDE SHOULDER	I-80	3610+65.0	RT	3611+14.8	RT	50
I-80 EB - INSIDE OVER BRIDGE	I-80	3611+14.8	RT	3614+31.7	RT	318
TOTAL						4486

REMOVAL OF GUARDRAIL ON BRIDGE WILL BE PAID FOR AS GUARDRAIL REMOVAL

PAVEMENT REMOVAL

LOCATION DESCRIPTION	ALIGNMENT	OFFSET DIRECTION	FROM	TO	PAVEMENT REMOVAL (SQ YD)
I-80 WB - APPROACH PAVEMENT	I-80	LT	3611+25.4	3611+65.6	105
I-80 WB - APPROACH PAVEMENT	I-80	LT	3614+25.7	3614+66.3	103
I-80 EB - APPROACH PAVEMENT	I-80	RT	3611+11.8	3611+52.0	106
I-80 EB - APPROACH PAVEMENT	I-80	RT	3611+48.5	3611+49.1	103
TOTAL					209

PAVED SHOULDER REMOVAL

LOCATION DESCRIPTION	ALIGNMENT	OFFSET DIRECTION	FROM	TO	SHOULDER REMOVAL (SQ YD)
I-80 WB - APPROACH OUTSIDE SHOULDER	I-80	LT	3611+25.7	3611+66.0	13
I-80 WB - APPROACH INSIDE SHOULDER	I-80	LT	3611+22.2	3611+62.4	14
I-80 WB - APPROACH OUTSIDE SHOULDER	I-80	LT	3614+26.2	3614+66.8	13
I-80 WB - APPROACH INSIDE SHOULDER	I-80	LT	3614+21.6	3614+61.9	15
I-80 EB - APPROACH OUTSIDE SHOULDER	I-80	RT	3611+14.7	3611+54.9	10
I-80 EB - APPROACH INSIDE SHOULDER	I-80	RT	3611+11.4	3611+51.7	14
I-80 EB - APPROACH OUTSIDE SHOULDER	I-80	RT	3614+12.1	3614+12.1	14
I-80 EB - APPROACH INSIDE SHOULDER	I-80	RT	3614+12.6	3614+53.3	19
TOTAL					111

TYLIN INTERNATIONAL	USER NAME = #USER#	DESIGNED - CAC	REVISED -	STATE OF ILLINOIS DEPARTMENT OF TRANSPORTATION	F.A.I. ROUTE 80 (I-80) SCHEDULE OF QUANTITIES REMOVAL / MISCELLANEOUS QUANTITIES SHEET 1 OF 3			F.A.I. RTE. 80	SECTION	COUNTY	TOTAL SHEETS	SHEET NO.
	PLLOT SCALE = #SCALE#	DRAWN - CAC	REVISED -		SCALE:	SHEET NO.	OF SHEETS	STA.	TO STA.	BUREAU	24	24
	PLLOT DATE = 8/17/2009	CHECKED - JDF	REVISED -		DATE - 08/14/2009	REVISED -	FED. ROAD DIST. NO.			ILLINOIS FED. AID PROJECT	CONTRACT NO. 66908	

P:\602429.1(I-80)\Road\602429.40.D\303803SCH01.dgn 8/17/2009 10:24:37 AM



PROPOSED PAVEMENT ITEMS

LOCATION DESCRIPTION	ALIGNMENT	OFFSET DIRECTION	FROM	TO	POLYM HMA SURF CSE "D" N105 1 3/4" (TON)	POLYM HMA BIND CSE "D" N105 2 3/4" (TON)	HMA BIND CSE IL-19 N90, 12 3/4" (TON)	HMA BIND CSE IL-19 N70, 4" (TON)	AGGREGATE BASE CSE A, 12" (SQ YD)	POLYM LEV BIND MM N90 3/4" MIN VAR DEPTH (TON)	AGGREGATE (PRIME COAT) (SQ YD)	POLYM BIT MATERIALS (PRIME COAT) (TON)	POLYM HMA SURF CSE "C" N50 1 3/4" (TON)	BIT MATERIALS (PRIME COAT) (TON)	HMA SHLD 12" (SQ YD)	AGGREGATE BASE CSE A, 6" (SQ YD)
I-80 WB - MAINLINE RESURFACING	I-80	LT	3603+00.0	3607+65.4	121					130	2.5	0.5				
I-80 EB - MAINLINE RESURFACING	I-80	RT	3603+00.0	3607+67.4	122					131	2.5	0.5				
I-80 WB - OUTSIDE SHOULDER	I-80	LT	3603+00.0	3607+65.3									46	0.20		
I-80 EB - OUTSIDE SHOULDER	I-80	RT	3603+00.0	3607+67.4									37	0.20		
I-80 WB - INSIDE SHOULDER	I-80	LT	3603+00.0	3607+65.9	19							0.1				
I-80 EB - INSIDE SHOULDER	I-80	RT	3603+00.0	3607+66.9	19							0.1				
I-80 WB - MAINLINE RESURFACING	I-80	LT	3610+47.3	3611+25.4	20					21	0.4	0.1				
I-80 EB - MAINLINE RESURFACING	I-80	RT	3610+46.4	3611+11.7	17					19	0.4	0.1				
I-80 WB - OUTSIDE SHOULDER	I-80	LT	3610+47.1	3611+22.2									2	0.10		
I-80 EB - OUTSIDE SHOULDER	I-80	RT	3610+46.7	3611+14.7									2	0.10		
I-80 WB - INSIDE SHOULDER	I-80	LT	3610+47.1	3611+22.2	2											
I-80 EB - INSIDE SHOULDER	I-80	RT	3610+46.7	3611+14.7	2											
I-80 WB - OUTSIDE FULL-DEPTH SHOULDER	I-80	LT	3606+14.6	3607+65.2											50	59
I-80 EB - OUTSIDE FULL-DEPTH SHOULDER	I-80	RT	3604+86.5	3607+67.6											148	163
I-80 WB - INSIDE FULL-DEPTH SHOULDER	I-80	LT	3603+00.0	3607+65.9											121	147
I-80 EB - INSIDE FULL-DEPTH SHOULDER	I-80	RT	3603+00.0	3607+66.9											85	111
I-80 WB - MAINLINE FULL-DEPTH	I-80	RT	3611+25.4	3614+66.4	89	139	646	203	905		1.8	0.7				
I-80 EB - MAINLINE FULL-DEPTH	I-80	LT	3611+11.7	3614+48.9	89	139	645	202	904		1.8	0.7				
I-80 WB - OUTSIDE FULL-DEPTH SHOULDER	I-80	LT	3610+47.4	3615+89.6											491	521
I-80 EB - OUTSIDE FULL-DEPTH SHOULDER	I-80	RT	3610+46.4	3616+16.4											500	531
I-80 WB - INSIDE FULL-DEPTH SHOULDER	I-80	LT	3610+47.1	3619+00.0											320	368
I-80 EB - INSIDE FULL-DEPTH SHOULDER	I-80	RT	3610+46.7	3619+00.0											346	393
I-80 WB - MAINLINE RESURFACING	I-80	LT	3614+66.4	3619+00.0	113					121	2.3	0.5				
I-80 EB - MAINLINE RESURFACING	I-80	RT	3614+48.9	3619+00.0	118					126	2.4	0.5				
I-80 WB - OUTSIDE SHOULDER	I-80	LT	3614+66.8	3619+00.0									42	0.20		
I-80 EB - OUTSIDE SHOULDER	I-80	RT	3614+48.5	3619+00.0									43	0.20		
I-80 WB - INSIDE SHOULDER	I-80	LT	3614+61.9	3619+00.0	22							0.1				
I-80 EB - INSIDE SHOULDER	I-80	RT	3614+53.3	3619+00.0	20							0.1				
TOTAL					774	279	1291	405	1809	550	14.1	3.9	172	1.00	2061	2294

HOT-MIX ASPHALT SHOULDERS, 6"

LOCATION DESCRIPTION	ALIGNMENT	OFFSET DIRECTION	FROM	TO	HMA SHLD 6" (SQ YD)
I-80 WB - OUTSIDE GUARDRAIL STABILIZATION	I-80	LT	3602+94.7	3607+80.1	161
I-80 EB - OUTSIDE GUARDRAIL STABILIZATION	I-80	RT	3600+94.9	3607+82.6	265
I-80 WB - INSIDE GUARDRAIL STABILIZATION	I-80	LT	3607+22.9	3607+81.0	19
I-80 EB - INSIDE GUARDRAIL STABILIZATION	I-80	RT	3603+16.5	3607+81.8	189
I-80 WB - OUTSIDE GUARDRAIL STABILIZATION	I-80	LT	3610+32.5	3619+79.8	348
I-80 EB - OUTSIDE GUARDRAIL STABILIZATION	I-80	RT	3610+31.3	361+98.7	294
I-80 WB - INSIDE GUARDRAIL STABILIZATION	I-80	LT	3610+32.1	3614+32.1	187
I-80 EB - INSIDE GUARDRAIL STABILIZATION	I-80	RT	3610+31.7	3610+31.7	19
TOTAL					1483

SHOULDER RUMBLE STRIPS

LOCATION DESCRIPTION	ALIGNMENT	OFFSET DIRECTION	FROM	TO	RUMBLE STRIP (EACH)
I-80 WB - OUTSIDE SHOULDER	I-80	LT	3603+00.0	3607+65.3	19
I-80 EB - OUTSIDE SHOULDER	I-80	RT	3603+00.0	3607+67.4	19
I-80 WB - INSIDE SHOULDER	I-80	LT	3603+00.0	3607+65.9	19
I-80 EB - INSIDE SHOULDER	I-80	RT	3603+00.0	3607+66.9	19
I-80 WB - OUTSIDE SHOULDER	I-80	LT	3610+47.1	3619+00.0	34
I-80 EB - OUTSIDE SHOULDER	I-80	RT	3610+46.7	3619+00.0	35
I-80 WB - INSIDE SHOULDER	I-80	LT	3610+47.1	3619+00.0	35
I-80 EB - INSIDE SHOULDER	I-80	RT	3610+46.7	3619+00.0	35
TOTAL					215

AGGREGATE SHOULDERS, TYPE B

LOCATION DESCRIPTION	ALIGNMENT	OFFSET DIRECTION	FROM	TO	AGG SHLD TYPE B (SQ YD)
I-80 WB - INSIDE SHOULDER	I-80	LT	3603+00.0	3607+22.9	43
I-80 EB - INSIDE SHOULDER	I-80	RT	3603+00.0	3603+21.1	2
I-80 WB - INSIDE SHOULDER	I-80	LT	3614+86.9	3619+00.0	41
I-80 EB - INSIDE SHOULDER	I-80	RT	3610+89.7	3619+00.0	82
TOTAL					168

<b>TYLIN INTERNATIONAL</b> USER NAME = #USER# PLOT SCALE = #SCALE# PLOT DATE = 8/14/2009	DESIGNED - CAC	REVISED -	<b>STATE OF ILLINOIS</b> <b>DEPARTMENT OF TRANSPORTATION</b>	<b>F.A.I. ROUTE 80 (I-80)</b> <b>SCHEDULE OF QUANTITIES</b> <b>PROPOSED QUANTITIES SHEET 2 OF 3</b>			F.A.I. RTE. 80	SECTION	COUNTY	TOTAL SHEETS	SHEET NO.
	DRAWN - CAC	REVISED -		SCALE:	SHEET NO.	OF SHEETS	STA.	TO STA.	BUREAU	344	25
	CHECKED - JDF	REVISED -					CONTRACT NO. 66908		ILLINOIS FED. AID PROJECT		
DATE - 08/14/2009	REVISED -						06-17BR & BR-1,7VB-M, 6BR & 6, 7 RS-1 & I				

EROSION CONTROL QUANTITIES

LOCATION DESCRIPTION	ALIGNMENT	OFFSET DIRECTION	FROM	TO	TEMP EROS CONTR SEED (POUND)	PERIMETER EROS BAR (FOOT)
I-80 WB - MAINLINE RESURFACING	I-80	LT	3603+00.0	3607+72.5	19	973.9
I-80 EB - MAINLINE RESURFACING	I-80	RT	3603+00.0	3607+74.4	18	990.7
MEDIAN	I-80	-	3603+00.0	3607+73.8	46	1038.8
I-80 WB - MAINLINE RESURFACING	I-80	LT	3610+40.7	3611+69.9	5	288.1
I-80 EB - MAINLINE RESURFACING	I-80	RT	3610+39.1	3611+50.2	4	254.7
MEDIAN	I-80	-	3610+39.6	3611+61.6	12	326.3
I-80 EB - MAINLINE FULL-DEPTH	I-80	RT	3611+69.9	3614+26.0	10	549.4
I-80 WB - MAINLINE FULL-DEPTH	I-80	LT	3611+50.2	3614+12.1	10	552.2
MEDIAN	I-80	-	3611+61.6	3614+12.1	25	607.5
I-80 WB - MAINLINE RESURFACING	I-80	LT	3614+26.0	3619+00.0	18	972.3
I-80 EB - MAINLINE RESURFACING	I-80	RT	3614+12.1	3619+00.0	21	1032.6
MEDIAN	I-80	-	3614+12.1	3619+00.0	49	1054.4
TOTAL					237	8641

LANDSCAPING QUANTITIES

LOCATION DESCRIPTION	ALIGNMENT	OFFSET DIRECTION	FROM	TO	SEEDING CLASS 3 (ACRE)	HEAVY DUTY EXCELSIOR BLANKET (SQ YD)	NITROGEN FERT NUTR (POUND)	PHOSPHORUS FERT NUTR (POUND)	POTASSIUM FERT NUTR (POUND)
I-80 WB - MAINLINE RESURFACING	I-80	LT	3603+00.0	3607+72.5	0.25	0.25	17	17	17
I-80 EB - MAINLINE RESURFACING	I-80	RT	3603+00.0	3607+74.4	0.25	0.25	16	16	16
MEDIAN	I-80	LT	3603+00.0	3607+73.8	0.50	0.50	42	42	42
I-80 WB - MAINLINE RESURFACING	I-80	LT	3610+40.7	3611+69.9	0.25	0.25	4	4	4
I-80 EB - MAINLINE RESURFACING	I-80	RT	3610+39.1	3611+50.2	0.25	0.25	4	4	4
MEDIAN	I-80	LT	3610+39.6	3611+61.6	0.25	0.25	11	11	11
I-80 EB - MAINLINE FULL-DEPTH	I-80	RT	3611+69.9	3614+26.0	0.25	0.25	9	9	9
I-80 WB - MAINLINE FULL-DEPTH	I-80	LT	3611+50.2	3614+12.1	0.25	0.25	9	9	9
MEDIAN	I-80	RT	3611+61.6	3614+12.1	0.25	0.25	22	22	22
I-80 WB - MAINLINE RESURFACING	I-80	LT	3614+26.0	3619+00.0	0.25	0.25	16	16	16
I-80 EB - MAINLINE RESURFACING	I-80	RT	3614+12.1	3619+00.0	0.25	0.25	18	18	18
MEDIAN	I-80	LT	3614+12.1	3619+00.0	0.50	0.50	44	44	44
TOTAL					3.50	3.50	213	213	213

GUARDRAIL AND TRAFFIC BARRIER TERMINALS

LOCATION DESCRIPTION	ALIGNMENT	FROM		TO		STEEL PLATE BEAM GR TYPE A (FOOT)	TRAFFIC BARRIER TERMINAL (EACH)	GUARDRAIL MARKERS (EACH)	TERM MRKERS DIRECT APPLIED (EACH)
		STATION	OFFSET	STATION	OFFSET				
I-80 EB - OUTSIDE SHOULDER	I-80	3601+30.0	70.4 RT	3601+80.3	66.0 RT		TYPE 1 *		1
I-80 EB - OUTSIDE SHOULDER	I-80	3601+80.3	66.0 RT	3607+39.3	66.8 RT	562.4		6	
I-80 EB - OUTSIDE SHOULDER	I-80	3607+39.3	66.8 RT	3607+82.6	67.3 RT		TYPE 6		
I-80 EB - INSIDE SHOULDER	I-80	3603+52.2	21.8 RT	3604+01.5	26.0 RT		TYPE 1 *		1
I-80 EB - INSIDE SHOULDER	I-80	3604+01.5	26.0 RT	3607+38.1	26.0 RT	337.5		4	
I-80 EB - INSIDE SHOULDER	I-80	3607+38.1	26.0 RT	3607+81.8	25.6 RT		TYPE 6		
I-80 EB - OUTSIDE SHOULDER	I-80	3610+31.3	67.3 RT	3610+75.1	66.8 RT		TYPE 6		
I-80 EB - OUTSIDE SHOULDER	I-80	3610+75.1	66.8 RT	3607+44.3	67.6 RT	824.9		7	
I-80 EB - OUTSIDE SHOULDER	I-80	3618+95.4	66.0 RT	361+98.7	66.8 RT		TYPE 2		
I-80 EB - INSIDE SHOULDER	I-80	3610+31.7	25.6 RT	3610+75.4	26.0 RT		TYPE 6		
I-80 EB - INSIDE SHOULDER	I-80	3610+75.4	26.0 RT	3610+89.7	25.2 RT		TYPE 2		
I-80 WB - INSIDE SHOULDER	I-80	3607+22.9	24.7 LT	3607+37.2	25.3 LT		TYPE 2		
I-80 WB - INSIDE SHOULDER	I-80	3607+42.0	24.4 LT	3607+73.1	24.8 LT		TYPE 6		
I-80 WB - OUTSIDE SHOULDER	I-80	3602+94.7	66.8 LT	3603+09.2	66.0 LT		TYPE 2		
I-80 WB - OUTSIDE SHOULDER	I-80	3603+09.2	66.0 LT	3607+36.5	66.0 LT	425.0		5	
I-80 WB - OUTSIDE SHOULDER	I-80	3607+36.5	66.0 LT	3607+80.2	66.5 LT		TYPE 6		
I-80 WB - INSIDE SHOULDER	I-80	3610+32.1	24.8 LT	3610+75.8	25.3 LT		TYPE 6		
I-80 WB - INSIDE SHOULDER	I-80	3610+75.8	25.3 LT	361+46.2	26.0 LT	329.5		4	
I-80 WB - INSIDE SHOULDER	I-80	361+46.2	26.0 LT	3614+55.7	21.7 LT		TYPE 1 *		1
I-80 WB - OUTSIDE SHOULDER	I-80	3610+32.4	66.5 LT	3610+76.2	66.0 LT		TYPE 6		
I-80 WB - OUTSIDE SHOULDER	I-80	3610+76.2	66.0 LT	3618+93.3	66.0 LT	812.5		7	
I-80 WB - OUTSIDE SHOULDER	I-80	3618+93.3	66.0 LT	3619+44.1	70.1 LT		TYPE 1 *		1
GUARDRAIL TOTAL (FOOT)						3292	-	-	-
* TOTAL TBT, TYPE 1 (SPECIAL) FLARED (EACH)						-	4	-	-
TOTAL TBT, TYPE 2 (EACH)						-	4	-	-
TOTAL TBT, TYPE 6 (EACH)						-	8	-	-
GUARDRAIL MARKERS (EACH)						-	-	33	-
TERMINAL MARKERS (EACH)						-	-	-	4

EARTH EXCAVATION SCHEDULE

DIRECTION OF TRAVEL	STATION TO STATION	EARTH EXCAVATION (CU YD)	REM & DIS OF UNSUITABLE MATERIAL (CU YD)	EARTH EXC. ADJ. FOR SHRINKAGE (CU YD)	EMBANKMENT (CU YD)	EARTHWORK BALANCE - WASTE (+) OR SHORTAGE (-) (CU YD)
EB I-80	STA. 3603+00 TO STA. 3607+97	29.9	481.8	22.4	2038.5	-2016.1
EB I-80	STA. 3610+17 TO STA. 3614+50	24.7	822.0	18.5	17925.0	-17906.4
EB I-80	STA. 3615+00 TO STA. 3619+00	40.6	298.9	30.4	803.5	-773.1
WB I-80	STA. 3603+00 TO STA. 3607+96	42.8	333.4	32.1	692.4	-660.3
WB I-80	STA. 3610+18 TO STA. 3614+50	75.6	1149.0	56.7	31318.4	-31261.8
WB I-80	STA. 3615+00 TO STA. 3619+00	65.4	159.0	49.0	180.0	-131.0
TOTALS =		278.9	3244.1	209.2	52957.8	-52748.6
TOTALS (ROUNDED TO NEAREST 5 CU YDS) =		280.0	3245.0	N/A	N/A	-52750.0

NOTES:

- STATION LIMITS, EXCAVATION QUANTITIES, AND EMBANKMENT QUANTITIES WERE TAKEN FROM CROSS SECTIONS.
- THE REMOVAL AND DISPOSAL OF UNSUITABLE MATERIAL QUANTITY WAS BASED ON A ASSUMED DEPTH OF 6 INCHES.
- EARTH EXCAVATION ADJUSTED FOR SHRINKAGE = EXCAVATION QUANTITY X (1-SHRINKAGE FACTOR (.25)).
- EARTHWORK BALANCE = EARTHWORK TO BE REMOVED (WASTE (+)) OR EARTHWORK REQUIRED (SHORTAGE (-)) : PAID FOR AS FURNISHED EXCAVATION).
- ALL PAY ITEMS HAVE BEEN ROUNDED UP TO THE NEAREST 5 CUBIC YARDS.
- THE TOP FOUR INCHES (4") SHALL BE VEGETATIVE SUSTAINING SOIL AND SHALL BE INCLUDED IN THE COST OF FURNISHED EXCAVATION.

ALIGNMENT AND SURVEY TIES FOR CONTROL POINT DATA

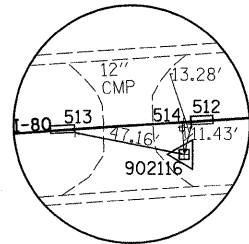

HORIZONTAL CONTROL POINT NO. 902116

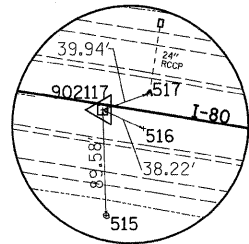

HORIZONTAL CONTROL POINT NO. 902117

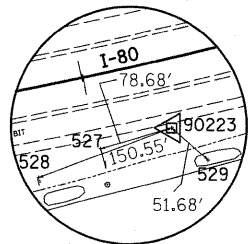

HORIZONTAL CONTROL POINT NO. 902223

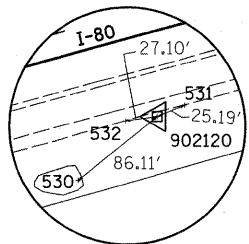

HORIZONTAL CONTROL POINT NO. 902120

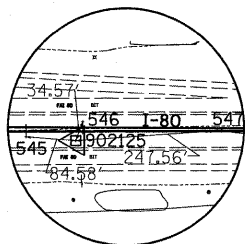

HORIZONTAL CONTROL POINT NO. 902125

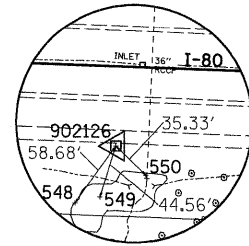

HORIZONTAL CONTROL POINT NO. 902126

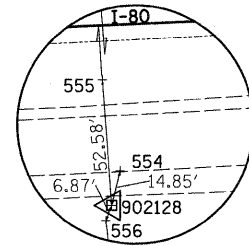

HORIZONTAL CONTROL POINT NO. 902128

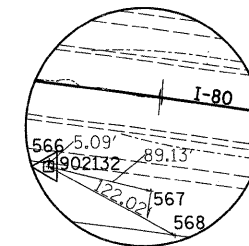

HORIZONTAL CONTROL POINT NO. 902132

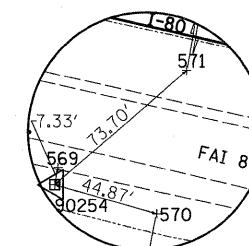

HORIZONTAL CONTROL POINT NO. 90254

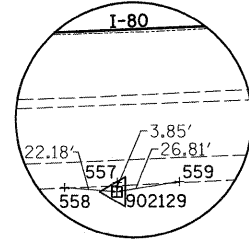

HORIZONTAL CONTROL POINT NO. 902129

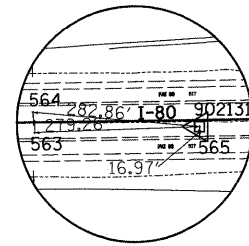

HORIZONTAL CONTROL POINT NO. 902131

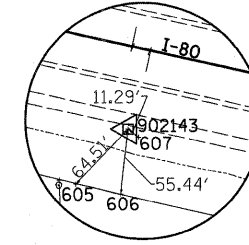

HORIZONTAL CONTROL POINT NO. 902143

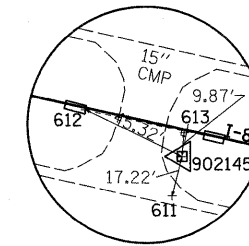

HORIZONTAL CONTROL POINT NO. 902145

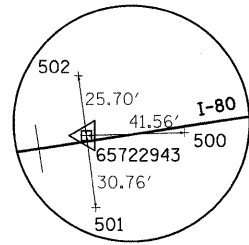
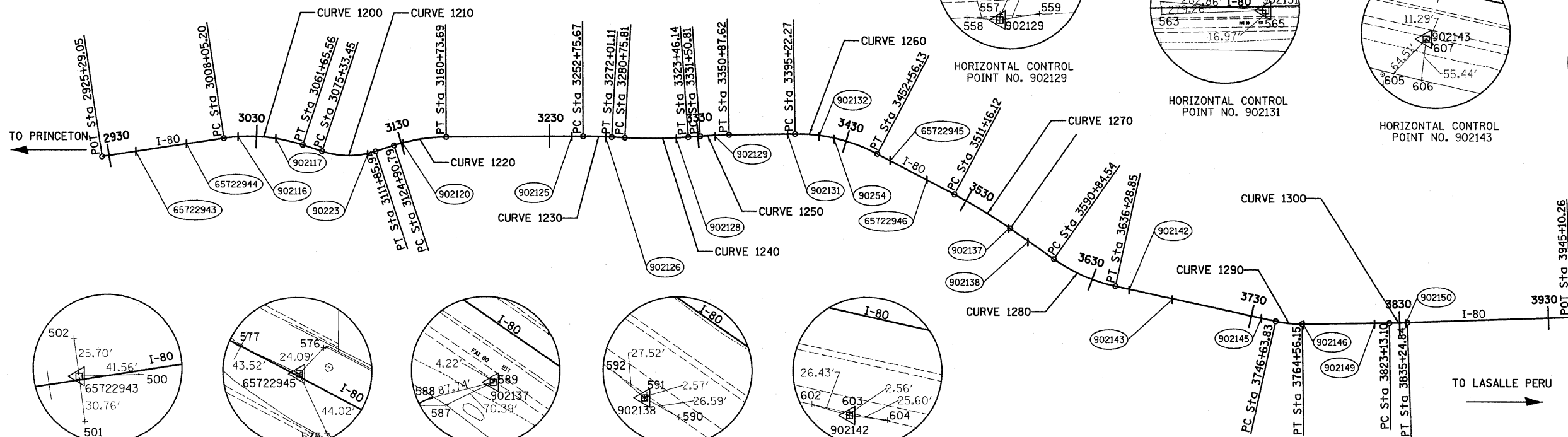

HORIZONTAL CONTROL POINT NO. 65722943

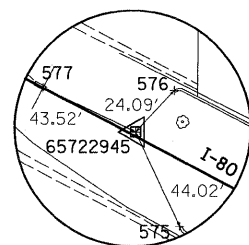

HORIZONTAL CONTROL POINT NO. 65722945

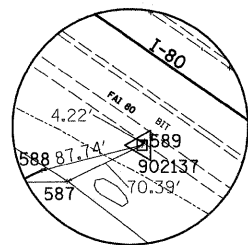

HORIZONTAL CONTROL POINT NO. 902137

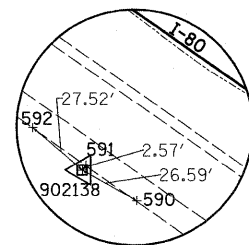

HORIZONTAL CONTROL POINT NO. 902138

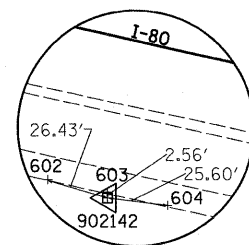

HORIZONTAL CONTROL POINT NO. 902142

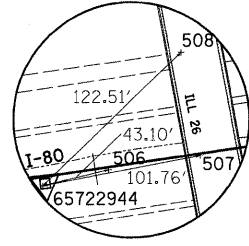

HORIZONTAL CONTROL POINT NO. 65722944

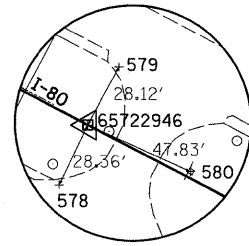

HORIZONTAL CONTROL POINT NO. 65722946

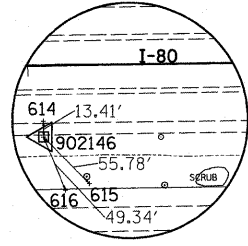

HORIZONTAL CONTROL POINT NO. 902146

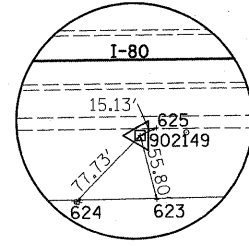

HORIZONTAL CONTROL POINT NO. 902149

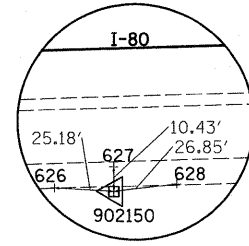

HORIZONTAL CONTROL POINT NO. 902150

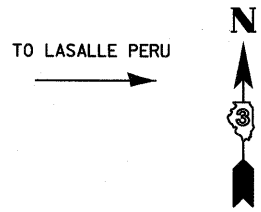

TYLIN INTERNATIONAL

USER NAME = #USER#  
 PLOT SCALE = #SCALE#  
 PLOT DATE = 8/14/2009

DESIGNED - CAC  
 DRAWN - CAC  
 CHECKED - JDF  
 DATE - 08/14/2009

REVISED -  
 REVISED -  
 REVISED -  
 REVISED -

STATE OF ILLINOIS  
 DEPARTMENT OF TRANSPORTATION

F.A.I. ROUTE 80 (I-80)  
 ALIGNMENT AND SURVEY TIES FOR CONTROL POINTS  
 SHEET 1 OF 3

SCALE: SHEET NO. OF SHEETS STA. TO STA.

F.A.I. RTE. NO.	SECTION	COUNTY	TOTAL SHEETS NO.	SHEET NO.
80		BUREAU	344	27
CONTRACT NO. 66908				

FED. ROAD DIST. NO. ILLINOIS FED. AID PROJECT  
 \* 06-17BR & BR-1,7VB-M, 6BR & 6, 7 RS-1 & I)

SURVEY TIES FOR CONTROL POINT DATA

REFERENCE TIES				
POINT	CHAIN	STATION	OFFSET	DESCRIPTION
500	I.80	2948+61.98	2.4622 RT	SIGN
501	I.80	2948+20.12	28.3404 RT	SHOULDER
502	I.80	2948+21.20	28.1148 LT	SHOULDER
506	I.80	2983+08.43	1.6911 RT	GUARDRAIL STEEL PLATE BEAM
507	I.80	2983+67.18	1.3407 RT	PIER
508	I.80	2983+65.01	65.951 LT	PIER
512	I.80	3017+65.64	1.0730 RT	HEADWALL
513	I.80	3017+16.01	1.4554 RT	HEADWALL
514	I.80	3017+61.53	2.2913 RT	SIGN
515	I.80	3043+20.00	92.5474 RT	TREE (DECIDUOUS) 10" DIA.
516	I.80	3043+39.95	14.8358 RT	DRAINAGE MARKER
517	I.80	3043+38.26	14.3909 LT	END SECTION FLARED
527	I.80	3105+42.73	77.3834 RT	DRAINAGE MARKER
528	I.80	3104+73.46	94.2496 RT	POLE, SIGN 256
529	I.80	3106+49.81	113.8377 RT	TREE DECIDUOUS : UNIT
530	I.80	3130+32.95	104.1797 RT	TREE DECIDUOUS : UNIT
531	I.80	3131+37.54	66.2971 RT	SHOULDER
532	I.80	3130+85.39	66.1331 RT	SHOULDER
536	I.80	3166+29.97	9.7100 LT	END SECTION FLARED
537	I.80	3166+59.26	13.5856 RT	POLE - SIGN
538	I.80	3166+05.65	2.4537 LT	G.R. STEEL PLATE BEAM
539	I.80	3194+39.77	0.0854 LT	G.R. STEEL PLATE BEAM
540	I.80	3195+00.68	1.3378 RT	PIER
541	I.80	3195+01.12	68.5399 RT	PIER
545	I.80	3244+38.72	8.9859 RT	DRAINAGE MARKER
546	I.80	3245+34.98	16.7440 LT	DRAINAGE MARKER
547	I.80	3247+70.01	1.3292 LT	G.R. STEEL PLATE BEAM
548	I.80	3267+80.03	118.3532 RT	TREE (DECIDUOUS) 12" DIA.
549	I.80	3268+01.10	112.6648 RT	TREE (DECIDUOUS) 18" DIA.
550	I.80	3268+39.37	93.1451 RT	END SECTION FLARED
554	I.80	3315+44.38	54.6931 RT	PAVEMENT STATION NUMBER
555	I.80	3315+38.67	16.3658 RT	DRAINAGE MARKER
556	I.80	3315+37.42	75.2348 RT	DRAINAGE MARKER
557	I.80	3341+65.15	65.0388 RT	SHOULDER
558	I.80	3341+42.85	66.1558 RT	SHOULDER
559	I.80	3341+91.57	65.6757 RT	SHOULDER
563	I.80	3387+39.34	17.4267 RT	DRAINAGE MARKER
564	I.80	3387+37.15	17.3570 LT	DRAINAGE MARKER
565	I.80	3390+18.10	28.3492 RT	SHOULDER
566	I.80	3411+50.19	64.3673 RT	SHOULDER
567	I.80	3412+39.26	78.9014 RT	DRAINAGE MARKER
568	I.80	3412+64.87	113.1959 RT	FENCE POST
569	I.80	3421+94.13	66.1397 RT	SHOULDER
570	I.80	3422+39.38	76.0419 RT	DRAINAGE MARKER
571	I.80	3422+38.42	14.3172 RT	DRAINAGE MARKER
575	I.80	3462+78.47	24.9892 RT	WINGWALL, TOP
576	I.80	3462+49.68	24.8977 LT	WINGWALL, TOP
577	I.80	3462+00.00	0.0538 LT	DROP BOX
578	I.80	3490+31.33	28.3308 RT	SHOULDER
579	I.80	3490+30.32	28.1211 LT	SHOULDER
580	I.80	3490+77.88	2.5957 LT	POLE, SIGN 256
587	I.80	3553+95.28	129.8053 RT	FENCE POST
588	I.80	3553+72.22	134.6312 RT	POLE - SIGN
589	I.80	3554+29.95	64.4250 RT	SHOULDER
590	I.80	3570+26.83	65.3346 RT	SHOULDER
591	I.80	3570+00.59	65.3589 RT	SHOULDER
592	I.80	3569+72.96	65.4223 RT	SHOULDER
602	I.80	3645+60.94	65.5923 RT	SHOULDER
603	I.80	3645+86.73	65.2439 RT	SHOULDER
604	I.80	3646+12.77	65.3270 RT	SHOULDER
605	I.80	3675+26.94	124.4519 RT	FENCE POST
606	I.80	3675+65.92	124.2644 RT	FENCE POST
607	I.80	3675+70.31	73.9592 RT	DRAINAGE MARKER
611	I.80	3736+81.52	28.3453 RT	SHOULDER
612	I.80	3736+37.87	0.8524 RT	HEADWALL
613	I.80	3736+80.77	1.3399 RT	SIGN
614	I.80	3765+57.86	47.4014 RT	PAVEMENT STATION NUMBER
615	I.80	3765+96.26	101.3317 RT	TREE (DECIDUOUS) 15" DIA.
616	I.80	3765+76.02	106.7136 RT	WARNING SIGN
623	I.80	3813+29.81	118.9996 RT	FENCE POST
624	I.80	3812+61.99	120.2362 RT	POLE - POWER
625	I.80	3813+30.27	58.5521 RT	SHOULDER
626	I.80	3834+04.46	58.8043 RT	SHOULDER
627	I.80	3834+29.81	50.5093 RT	SHOULDER
628	I.80	3834+56.24	58.6326 RT	SHOULDER

BENCH MARKS							
POINT	NORTHING	EASTING	ELEVATION	CHAIN	STATION	OFFSET	DESCRIPTION
402	1714759.3550	2550617.0150	625.1780	I.80	3640+36.11	129.9904 RT	R.O.W. MARKER
406	1725024.6490	2505949.0090	706.2920	I.80	3167+40.76	109.5704 LT	PERMANENT SURVEY MARKER
407	1724706.1510	2517337.7300	663.6160	I.80	3281+39.48	172.4062 RT	PERMANENT SURVEY MARKER
408	1725009.6510	2531449.8710	692.9080	I.80	3422+41.05	139.1491 LT	PERMANENT SURVEY MARKER
409	1714570.3870	2552656.4200	629.2550	I.80	3660+68.76	121.4059 LT	PLUG
416	1724901.0370	2491293.6330	688.4970	I.80	3017+65.75	0.6214 LT	HEADWALL
417	1724851.4500	2493871.1340	697.2850	I.80	3043+40.14	71.1429 LT	HEADWALL
419	1723673.8430	2499408.4280	726.8370	I.80	3100+42.67	2.4070 RT	DROP BOX
420	1724432.7040	2502508.8180	720.5090	I.80	3132+39.85	115.5695 RT	R.O.W. MARKER
421	1724836.7020	2504046.6050	709.7230	I.80	3148+34.86	0.6472 LT	HEADWALL
422	1724827.8280	2505873.4710	706.9450	I.80	3166+63.97	86.7627 RT	SIGN FOUNDATION
423	1724926.3690	2508817.8420	696.3400	I.80	3196+08.91	7.0841 RT	HEADWALL
425	1725088.0300	2513763.3420	681.3640	I.80	3245+55.34	122.8948 LT	POLE FOUNDATION
426	1724943.0980	2516039.3060	672.1140	I.80	3268+30.91	0.3293 RT	DROP BOX
427	1724758.0440	2519439.0650	682.1050	I.80	3302+32.04	80.7066 RT	HEADWALL
428	1724786.2550	2521151.5500	681.4720	I.80	3319+39.70	115.2064 RT	R.O.W. MARKER
429	1724923.0790	2523640.3130	682.5360	I.80	3344+35.81	134.8923 RT	R.O.W. MARKER
431	1725261.6800	2527936.4380	722.0390	I.80	3387+39.62	125.4638 LT	R.O.W. MARKER
432	1724972.4550	2530119.2690	692.9340	I.80	3409+34.90	114.3023 RT	R.O.W. MARKER
437	1718621.8110	2543232.1610	679.6250	I.80	3556+72.24	144.5014 RT	R.O.W. MARKER
438	1717684.5830	2544589.8170	641.4060	I.80	3573+21.94	134.5713 RT	R.O.W. MARKER
443	1714021.7980	2554014.3380	651.2730	I.80	3675+12.56	124.1966 RT	R.O.W. MARKER
445	1712821.6900	2560074.6520	650.2120	I.80	3736+89.33	0.9506 RT	HEADWALL
446	1712522.4990	2562862.7440	641.3600	I.80	3765+13.97	87.0867 LT	SIGN FOUNDATION
450	1712468.9540	2569927.9050	645.2120	I.80	3835+76.13	79.9378 RT	SIGN FOUNDATION
451	1712557.6530	2572525.4760	640.9330	I.80	3861+75.22	81.0290 RT	SIGN FOUNDATION

MAIN CONTROL POINTS							
POINT	NORTHING	EASTING	ELEVATION	CHAIN	STATION	OFFSET	DESCRIPTION
65722943	1723907.0080	2484421.0520	685.8370	I.80	2948+20.71	2.4184 LT	D-2 NETWORK MONUMENT
65722944	1724412.8900	2487828.5160	669.5430	I.80	2982+65.51	5.5272 RT	D-2 NETWORK MONUMENT
65722945	1723381.1340	2535116.9730	673.2240	I.80	3462+43.42	1.6387 LT	D-2 NETWORK MONUMENT
65722946	1722085.2410	2537584.0370	685.3890	I.80	3490+30.13	0.0010 LT	D-2 NETWORK MONUMENT
77700683	1740374.1750	2584378.7250	662.7300	I.80	3945+10.26	27309.3993 LT	VERTICAL CONTROL STATION
77700691	1719181.1260	2584820.2680	646.4700	I.80	3945+10.26	6113.7469 LT	VERTICAL CONTROL STATION
77700896	1723139.3050	2535186.7440	655.8450	I.80	3464+17.54	180.1088 RT	N.G.S MONUMENT (WINGWALL)
77700943	1712438.6560	2566844.4700	637.6340	I.80	3804+94.11	53.1444 RT	N.G.S MONUMENT (ABUTMENT)
77700944	1712338.7160	2568322.1850	651.7120	I.80	3819+70.26	174.0044 RT	N.G.S. MONUMENT
77700945	1712326.3280	2568805.1560	651.4200	I.80	3824+52.56	193.3961 RT	N.G.S. MONUMENT
77700948	1712360.2580	2568834.2910	651.0270	I.80	3824+82.17	159.9591 RT	N.G.S. MONUMENT
77701804	1708278.9860	2574984.2320	648.5940	I.80	3884+84.69	4442.0837 RT	N.G.S. MONUMENT

HORIZONTAL CONTROL POINTS							
POINT	NORTHING	EASTING	ELEVATION	CHAIN	STATION	OFFSET	DESCRIPTION
902116	1724886.4510	2491290.4220	689.7590	I.80	3017+61.58	13.7207 RT	GPS CONTROL POINT
902117	1724782.4870	2493822.6170	696.8670	I.80	3043+03.12	4.5622 RT	GPS CONTROL POINT
902120	1724444.7540	2502374.8630	719.7880	I.80	3131+12.42	69.6123 RT	GPS CONTROL POINT
902122	1724905.5050	2505785.2980	707.4040	I.80	3165+76.29	8.5225 RT	GPS CONTROL POINT
902123	1724918.9560	2508616.3790	698.2400	I.80	3194+07.40	13.2065 RT	GPS CONTROL POINT
902125	1724949.2360	2513731.9210	686.7010	I.80	3245+23.03	15.6951 RT	GPS CONTROL POINT
902126	1724874.5230	2516018.5490	675.4660	I.80	3268+12.89	69.6793 RT	GPS CONTROL POINT
902128	1724810.1500	2520748.9460	685.7710	I.80	3315+40.13	68.9230 RT	GPS CONTROL POINT
902129	1724978.2930	2523367.7990	677.8420	I.80	3341+64.90	68.8775 RT	GPS CONTROL POINT
902131	1725129.5200	2528217.6120	713.1840	I.80	3390+18.54	11.3903 RT	GPS CONTROL POINT
902132	1724992.3500	2530336.4390	697.9340	I.80	3411+50.05	69.4550 RT	GPS CONTROL POINT
90223	1723703.6970	2499992.8100	717.7350	I.80	3106+20.21	71.8124 RT	GPS CONTROL POINT
90254	1724812.2220	2531358.0680	686.4740	I.80	3421+94.29	73.4721 RT	GPS CONTROL POINT
902137	1718822.5420	2543077.3640	670.6570	I.80	3554+30.21	68.6352 RT	GPS CONTROL POINT
902138	1717923.4870	2544364.4760	653.1530	I.80	3570+00.37	67.9168 RT	GPS CONTROL POINT
902142	1714702.3300	2551168.7580	626.4430	I.80	3645+87.28	67.7423 RT	GPS CONTROL POINT
902143	1714065.4280	2554072.5620	649.6630	I.80	3675+60.11	69.1279 RT	GPS CONTROL POINT
902145	1712813.3110	2560065.3190	650.6230	I.80	3736+82.01	11.1312 RT	GPS CONTROL POINT
902146	1712375.2420	2562908.7930	642.8370	I.80	3765+57.93	60.8078 RT	GPS CONTROL POINT
902149	1712438.6350	2567666.9360	648.5340	I.80	3813+16.50	64.8146 RT	GPS CONTROL POINT
902150	1712482.9510	2569780.6210	649.3930	I.80	3834+29.52	60.9375 RT	GPS CONTROL POINT

TYLIN INTERNATIONAL	USER NAME = #USER#	DESIGNED - CAC	REVISED -
	PLOT SCALE = #SCALE#	DRAWN - CAC	REVISED -
	PLOT DATE = 8/14/2009	CHECKED - JDF	REVISED -
		DATE - 08/14/2009	REVISED -

STATE OF ILLINOIS  
DEPARTMENT OF TRANSPORTATION

F.A.I. ROUTE 80 (I-80)  
ALIGNMENT AND SURVEY TIES FOR CONTROL POINTS  
SHEET 2 OF 3

SCALE:	SHEET NO.	OF	SHEETS	STA.	TO STA.
--------	-----------	----	--------	------	---------

F.A.I. RTE. 80	SECTION	COUNTY	TOTAL SHEETS	SHEET NO.
		BUREAU	344	28
FED. ROAD DIST. NO.			CONTRACT NO. 66908	
ILLINOIS FED. AID PROJECT				
06-L7BR & BR-1,7VB-M, 6BR & 6, 7 RS-1 & 1J				

ALIGNMENT - HORIZONTAL CURVE DATA

Chain I80 contains:  
 1 CUR 1200 CUR 1210 CUR 1220 CUR 1230 CUR 1240 CUR 1250 CUR 1260 CUR 1270 CUR 1280  
 CUR 1290 CUR 1300 38

Beginning chain I80 description

Point 1 N 1,723,562.8520 E 2,482,155.3860 Sta 2925+29.05

Course from 1 to PC 1200 N 81° 25' 23.6256" E Dist 8,276.1506

**Curve Data**  
 \*-----\*

Curve 1200  
 P.I. Station = 3035+35.33 N 1,725,204.2673 E 2,493,038.5799  
 Delta = 26° 47' 48.2692" (RT)  
 Degree = 0° 29' 59.6601"  
 Tangent = 2,730.1272  
 Length = 5,360.3606  
 Radius = 11,461.3203  
 External = 320.6769  
 Long Chord = 5,311.6398  
 Mid. Ord. = 311.9489  
 P.C. Station = 3008+05.20 N 1,724,797.1113 E 2,490,338.9838  
 P.T. Station = 3061+65.56 N 1,724,350.6493 E 2,495,631.8271  
 C.C. = 1,713,463.9637 E 2,492,048.2617  
 Back = N 81° 25' 23.6256" E  
 Ahead = S 71° 46' 48.1051" E  
 Chord Bear = S 85° 10' 42.2398" E

Course from PT 1200 to PC 1210 S 71° 46' 48.1052" E Dist 1,367.8882

**Curve Data**  
 \*-----\*

Curve 1210  
 P.I. Station = 3094+24.01 N 1,723,331.8434 E 2,498,726.9066  
 Delta = 36° 28' 59.0837" (LT)  
 Degree = 0° 59' 55.8749"  
 Tangent = 1,890.5598  
 Length = 3,652.4931  
 Radius = 5,736.1507  
 External = 303.5216  
 Long Chord = 3,591.1007  
 Mid. Ord. = 288.2682  
 P.C. Station = 3075+33.45 N 1,723,922.9571 E 2,496,931.1336  
 P.T. Station = 3111+85.94 N 1,723,924.3090 E 2,500,522.2341  
 C.C. = 1,729,371.5152 E 2,498,724.6330  
 Back = S 71° 46' 48.1051" E  
 Ahead = N 71° 44' 12.8112" E  
 Chord Bear = N 89° 58' 42.3530" E

Course from PT 1210 to PC 1220 N 71° 44' 12.8112" E Dist 1,304.8427

**Curve Data**  
 \*-----\*

Curve 1220  
 P.I. Station = 3142+96.95 N 1,724,899.2384 E 2,503,476.5279  
 Delta = 17° 53' 45.9362" (RT)  
 Degree = 0° 29' 58.1483"  
 Tangent = 1,806.1602  
 Length = 3,582.9045  
 Radius = 11,470.9563  
 External = 141.3240  
 Long Chord = 3,568.3578  
 Mid. Ord. = 139.6040  
 P.C. Station = 3124+90.79 N 1,724,333.2220 E 2,501,761.3485  
 P.T. Station = 3160+73.69 N 1,724,910.8079 E 2,505,282.6511  
 C.C. = 1,713,440.0869 E 2,505,356.1291  
 Back = N 71° 44' 12.8112" E  
 Ahead = N 89° 37' 58.7474" E  
 Chord Bear = N 80° 41' 05.7793" E

Course from PT 1220 to PC 1230 N 89° 37' 58.7474" E Dist 9,201.9752

**Curve Data**  
 \*-----\*

Curve 1230  
 P.I. Station = 3262+38.66 N 1,724,975.9203 E 2,515,447.4077  
 Delta = 3° 18' 37.4708" (RT)  
 Degree = 0° 10' 18.9466"  
 Tangent = 962.9899  
 Length = 1,925.4440  
 Radius = 33,325.1364  
 External = 13.9108  
 Long Chord = 1,925.1762  
 Mid. Ord. = 13.9050  
 P.C. Station = 3252+75.67 N 1,724,969.7518 E 2,514,484.4375  
 P.T. Station = 3272+01.11 N 1,724,926.4714 E 2,516,409.1272  
 C.C. = 1,691,645.2991 E 2,514,697.9040  
 Back = N 89° 37' 58.7474" E  
 Ahead = S 87° 03' 23.7818" E  
 Chord Bear = S 88° 42' 42.5172" E

Course from PT 1230 to PC 1240 S 87° 03' 23.7818" E Dist 874.6988

**Curve Data**  
 \*-----\*

Curve 1240  
 P.I. Station = 3302+13.75 N 1,724,771.7743 E 2,519,417.7938  
 Delta = 7° 09' 05.8557" (LT)  
 Degree = 0° 10' 02.9006"  
 Tangent = 2,137.9422  
 Length = 4,270.3315  
 Radius = 34,212.0736  
 External = 66.7358  
 Long Chord = 4,267.5599  
 Mid. Ord. = 66.6059  
 P.C. Station = 3280+75.81 N 1,724,881.5562 E 2,517,282.6720  
 P.T. Station = 3323+46.14 N 1,724,928.6597 E 2,521,549.9720  
 C.C. = 1,759,048.4957 E 2,519,039.4389  
 Back = S 87° 03' 23.7818" E  
 Ahead = N 85° 47' 30.3626" E  
 Chord Bear = N 89° 22' 03.2904" E

Course from PT 1240 to PC 1250 N 85° 47' 30.3626" E Dist 804.6665

**Curve Data**  
 \*-----\*

Curve 1250  
 P.I. Station = 3341+19.47 N 1,725,058.7896 E 2,523,318.5236  
 Delta = 3° 14' 52.3904" (RT)  
 Degree = 0° 10' 03.6921"  
 Tangent = 968.6661  
 Length = 1,936.8134  
 Radius = 34,167.2170  
 External = 13.7284  
 Long Chord = 1,936.5541  
 Mid. Ord. = 13.7229  
 P.C. Station = 3331+50.81 N 1,724,987.7074 E 2,522,352.4691  
 P.T. Station = 3350+87.62 N 1,725,075.0248 E 2,524,287.0537  
 C.C. = 1,690,912.6072 E 2,524,859.7107  
 Back = N 85° 47' 30.3626" E  
 Ahead = N 89° 02' 22.7529" E  
 Chord Bear = N 87° 24' 56.5577" E

Course from PT 1250 to PC 1260 N 89° 02' 22.7529" E Dist 4,434.6464

**Curve Data**  
 \*-----\*

Curve 1260  
 P.I. Station = 3424+50.42 N 1,725,198.4284 E 2,531,648.8161  
 Delta = 28° 38' 18.9861" (RT)  
 Degree = 0° 29' 58.0721"  
 Tangent = 2,928.1503  
 Length = 5,733.8626  
 Radius = 11,471.4422  
 External = 367.8167  
 Long Chord = 5,674.3597  
 Mid. Ord. = 356.3895  
 P.C. Station = 3395+22.27 N 1,725,149.3513 E 2,528,721.0772  
 P.T. Station = 3452+56.13 N 1,723,838.2848 E 2,534,241.8980  
 C.C. = 1,713,679.5205 E 2,528,913.3434  
 Back = N 89° 02' 22.7529" E  
 Ahead = S 62° 19' 18.2610" E  
 Chord Bear = S 76° 38' 27.7540" E

Course from PT 1260 to PC 1270 S 62° 19' 18.2610" E Dist 5,859.9896

**Curve Data**  
 \*-----\*

Curve 1270  
 P.I. Station = 3533+10.86 N 1,720,096.8143 E 2,541,374.9237  
 Delta = 7° 17' 06.0849" (RT)  
 Degree = 0° 09' 58.2823"  
 Tangent = 2,194.7393  
 Length = 4,383.5634  
 Radius = 34,476.1659  
 External = 69.7875  
 Long Chord = 4,380.6112  
 Mid. Ord. = 69.6465  
 P.C. Station = 3511+16.12 N 1,721,116.2840 E 2,539,431.3286  
 P.T. Station = 3554+99.68 N 1,718,839.1159 E 2,543,173.5552  
 C.C. = 1,690,585.2281 E 2,523,416.9401  
 Back = S 62° 19' 18.2610" E  
 Ahead = S 55° 02' 12.1761" E  
 Chord Bear = S 58° 40' 45.2185" E

Course from PT 1270 to PC 1280 S 55° 02' 12.1761" E Dist 3,584.8541

**Curve Data**  
 \*-----\*

Curve 1280  
 P.I. Station = 3613+86.67 N 1,715,465.5682 E 2,547,998.0576  
 Delta = 22° 37' 08.3647" (LT)  
 Degree = 0° 29' 51.8721"  
 Tangent = 2,302.1355  
 Length = 4,544.3180  
 Radius = 11,511.1346  
 External = 227.9475  
 Long Chord = 4,514.8661  
 Mid. Ord. = 223.5212  
 P.C. Station = 3590+84.54 N 1,716,784.8102 E 2,546,111.4128  
 P.T. Station = 3636+28.85 N 1,714,973.4046 E 2,550,246.9691  
 C.C. = 1,726,218.4086 E 2,552,707.8846  
 Back = S 55° 02' 12.1761" E  
 Ahead = S 77° 39' 20.5408" E  
 Chord Bear = S 66° 20' 46.3584" E

Course from PT 1280 to PC 1290 S 77° 39' 20.5408" E Dist 11,034.9722

**Curve Data**  
 \*-----\*

Curve 1290  
 P.I. Station = 3755+63.95 N 1,712,421.8529 E 2,561,906.1298  
 Delta = 13° 09' 21.0543" (LT)  
 Degree = 0° 44' 02.4364"  
 Tangent = 900.1208  
 Length = 1,792.3252  
 Radius = 7,805.8570  
 External = 51.7267  
 Long Chord = 1,788.3905  
 Mid. Ord. = 51.3861  
 P.C. Station = 3746+63.83 N 1,712,614.2859 E 2,561,026.8193  
 P.T. Station = 3764+56.15 N 1,712,434.6021 E 2,562,806.1603  
 C.C. = 1,720,239.6761 E 2,562,695.5996  
 Back = S 77° 39' 20.5408" E  
 Ahead = N 89° 11' 18.4049" E  
 Chord Bear = S 84° 14' 01.0679" E

Course from PT 1290 to PC 1300 N 89° 11' 18.4049" E Dist 5,856.9468

**Curve Data**  
 \*-----\*

Curve 1300  
 P.I. Station = 3829+18.99 N 1,712,526.1406 E 2,569,268.3499  
 Delta = 1° 10' 05.5736" (LT)  
 Degree = 0° 05' 47.0690"  
 Tangent = 605.8910  
 Length = 1,211.7400  
 Radius = 59,430.4941  
 External = 3.0884  
 Long Chord = 1,211.7190  
 Mid. Ord. = 3.0883  
 P.C. Station = 3823+13.10 N 1,712,517.5588 E 2,568,662.5196  
 P.T. Station = 3835+24.84 N 1,712,547.0720 E 2,569,873.8792  
 C.C. = 1,771,942.0913 E 2,567,820.7569  
 Back = N 89° 11' 18.4049" E  
 Ahead = N 88° 01' 12.8313" E  
 Chord Bear = N 88° 36' 15.6181" E

Course from PT 1300 to PC 38 N 88° 01' 12.8313" E Dist 10,985.4171

Point 38 N 1,712,926.5810 E 2,580,852.7390 Sta 3945+10.26

Ending chain I80 description

CURVE POINT NUMBERS				
CURVE	PI	CC	PC	PT
1200	1200	1201	1202	1203
1210	1210	1211	1212	1213
1220	1220	1221	1222	1223
1230	1230	1231	1232	1233
1240	1240	1241	1242	1243
1250	1250	1251	1252	1253

CURVE POINT NUMBERS (continued)				
CURVE	PI	CC	PC	PT
1260	1260	1261	1262	1263
1270	1270	1271	1272	1273
1280	1280	1281	1282	1283
1290	1290	1291	1292	1293
1300	1300	1301	1302	1303



PROJECT BEGINS  
STA 1405 + 64

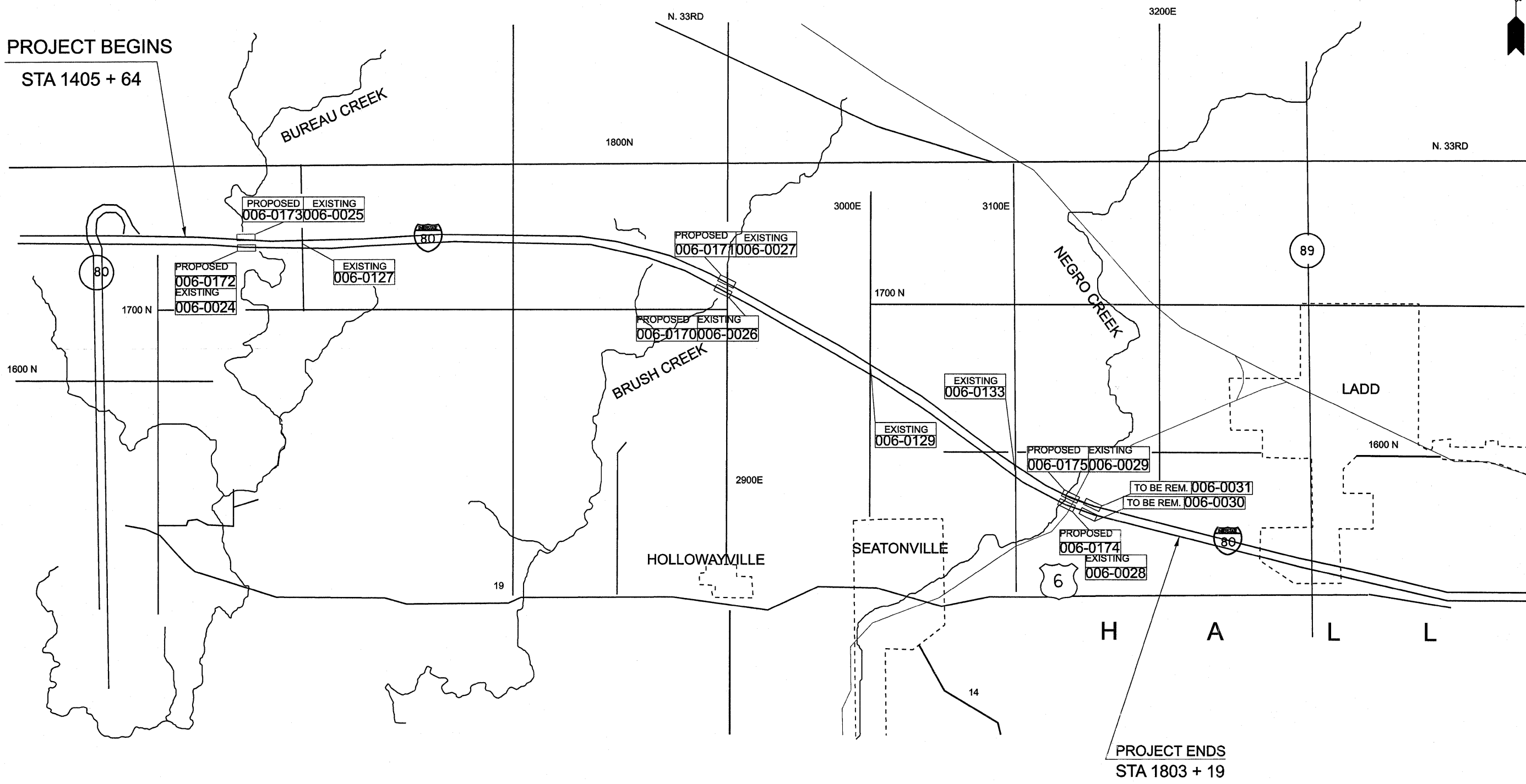

PROJECT ENDS  
STA 1803 + 19

\*\*06-[7BR&BR-1,7VB-M,6BR&6.7 RS-1 & I]

FILE NAME = c:\pwork\pwork\braboypo\d0112640\d368	USER NAME = braboypo	DESIGNED - ---	REVISED - ---	<b>STATE OF ILLINOIS DEPARTMENT OF TRANSPORTATION</b>	<b>LOCATION MAP</b>	F.A. RTE. = I-80	SECTION **	COUNTY BUREAU	TOTAL SHEETS 344	SHEET NO. 30	
PLOT SCALE = 58.7353' / IN.		CHECKED - ---	REVISED - ---			SCALE: _____	SHEET NO. ___ OF ___ SHEETS	CONTRACT NO. 66908		ILLINOIS FED. AID PROJECT	
PLOT DATE = Sep 07, 2009 - 02:16:19 PM		DATE - ---	REVISED - ---			STA. _____ TO STA. _____					

EXIST. CURVE 1808UR-4  
 PI STA. = 1411+96.95  
 Δ = 3° 18' 13" (RT)  
 D = 0° 10' 00"  
 R = 34,397.77'  
 T = 991.95'  
 L = 1,983.34'  
 E = 14.30'  
 e = ----  
 T.R. = ----  
 S.E. RUN = ----  
 P.C. STA. = 1402+05.00  
 P.T. STA. = 1421+88.35

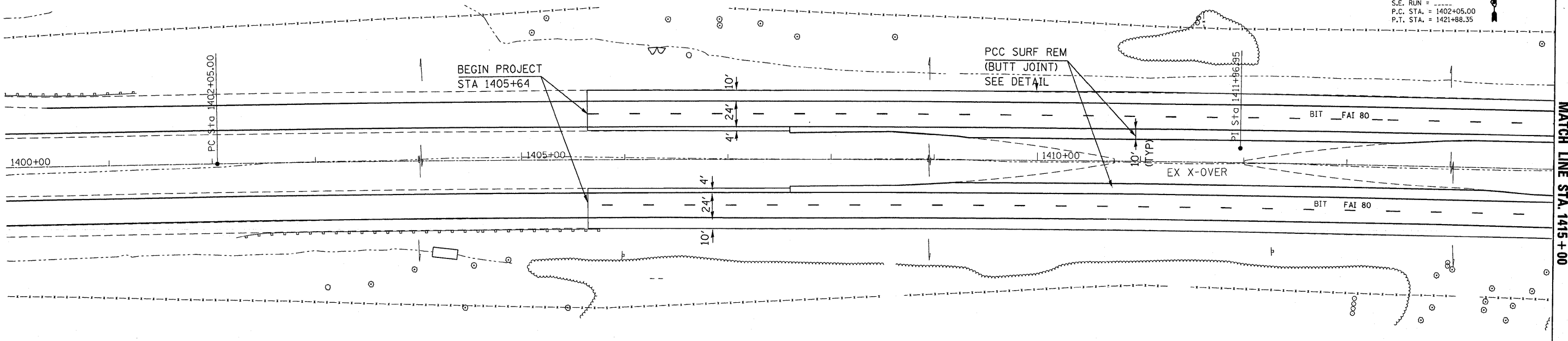

MATCH LINE STA. 1415+00

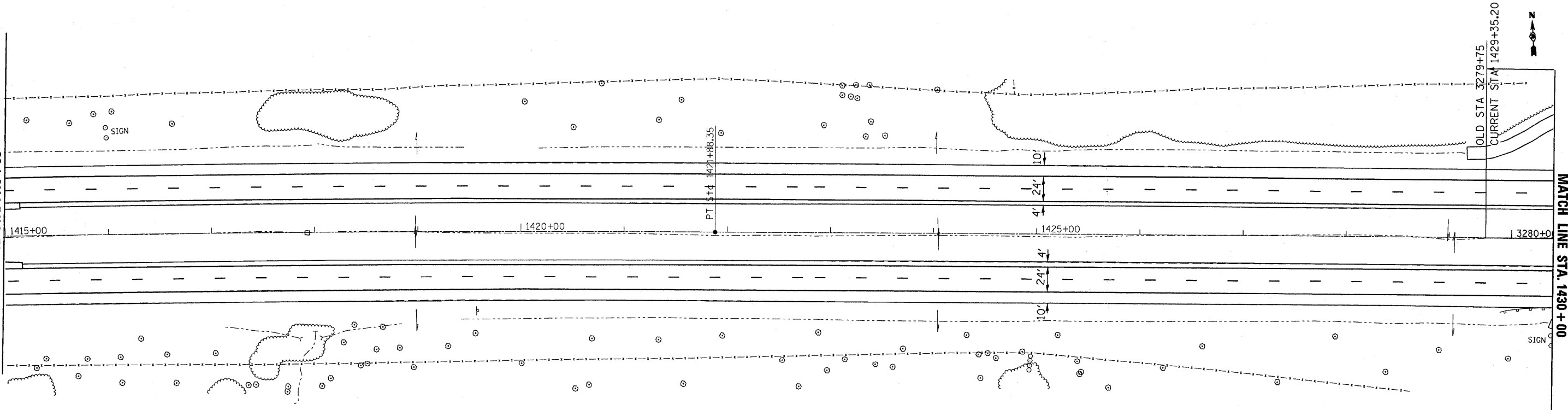

MATCH LINE STA. 1415+00

MATCH LINE STA. 1430+00

FILE NAME =	USER NAME = braboypc	DESIGNED -	REVISED -
c:\pwwork\pwwork\braboypc\d0112640\d3689088-sht-plan.dgn		DRAWN -	REVISED -
	PLOT SCALE = 50.0000' / IN.	CHECKED -	REVISED -
	PLOT DATE = Sep 07, 2009 - 01:26:22 PM	DATE -	REVISED -

STATE OF ILLINOIS  
 DEPARTMENT OF TRANSPORTATION

PLANS SHEETS STA 1400+00 TO STA 1430+00

SCALE: SHEET NO. OF SHEETS STA. TO STA.

\*\*06-[7BR&BR-1,7VB-M,6BR&6,7 RS-1 & I]

F.A. RTE.	SECTION	COUNTY	TOTAL SHEETS	SHEET NO.
1-80	**	BUREAU	344	31
CONTRACT NO. 66908			ILLINOIS FED. AID PROJECT	

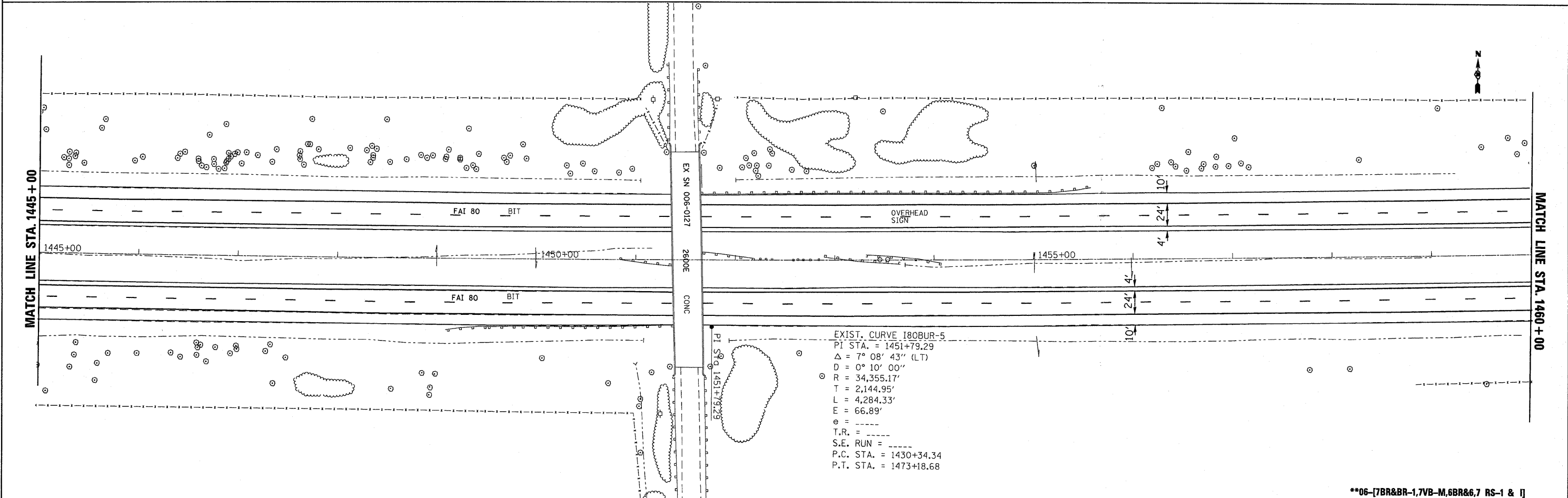
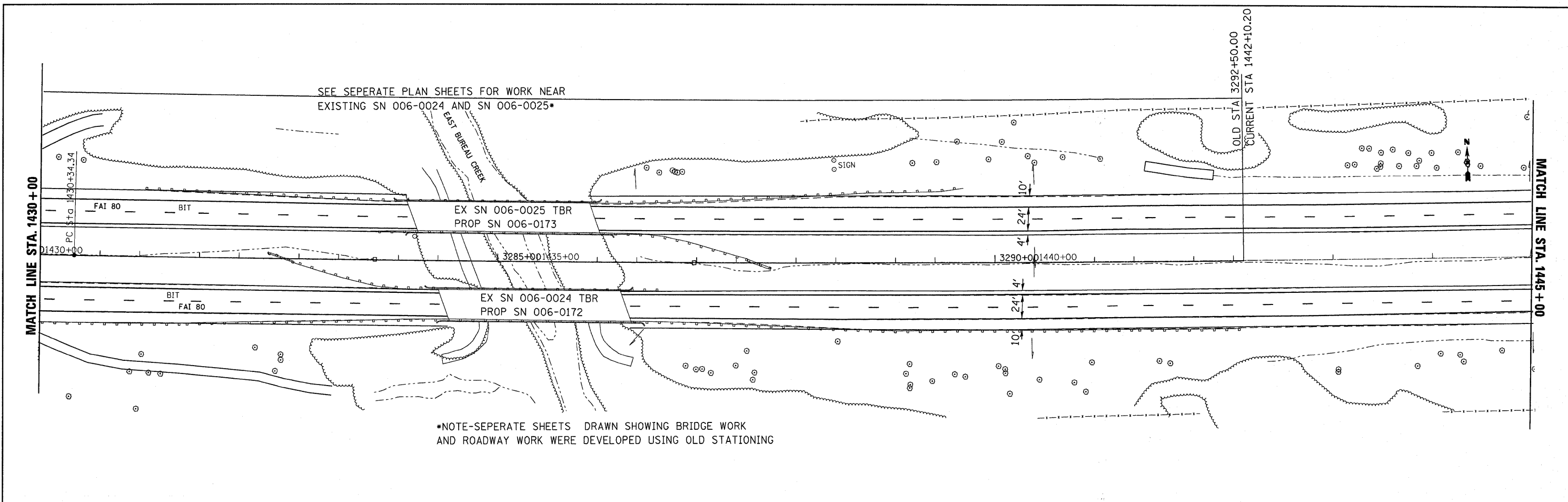

FILE NAME =	USER NAME = braboypc	DESIGNED -	REVISED -
c:\pwwork\pwwork\braboypc\d0112640\d368908-sht-plan.dgn		DRAWN -	REVISED -
PLOT SCALE = 50.0000' / IN.		CHECKED -	REVISED -
PLOT DATE = Sep 07, 2009 - 01:26:15 PM		DATE -	REVISED -

**STATE OF ILLINOIS  
DEPARTMENT OF TRANSPORTATION**

**PLANS SHEETS STA 1430+00 TO STA 1460+00**

SCALE: \_\_\_\_\_ SHEET NO. \_\_\_\_ OF \_\_\_\_ SHEETS STA. \_\_\_\_\_ TO STA. \_\_\_\_\_

F.A. RTE. I-80	SECTION **	COUNTY BUREAU	TOTAL SHEETS 344	SHEET NO. 32
CONTRACT NO. 66908			ILLINOIS FED. AID PROJECT	

\*\*06-[7BR&BR-1,7VB-M,6BR&6,7 RS-1 & I]



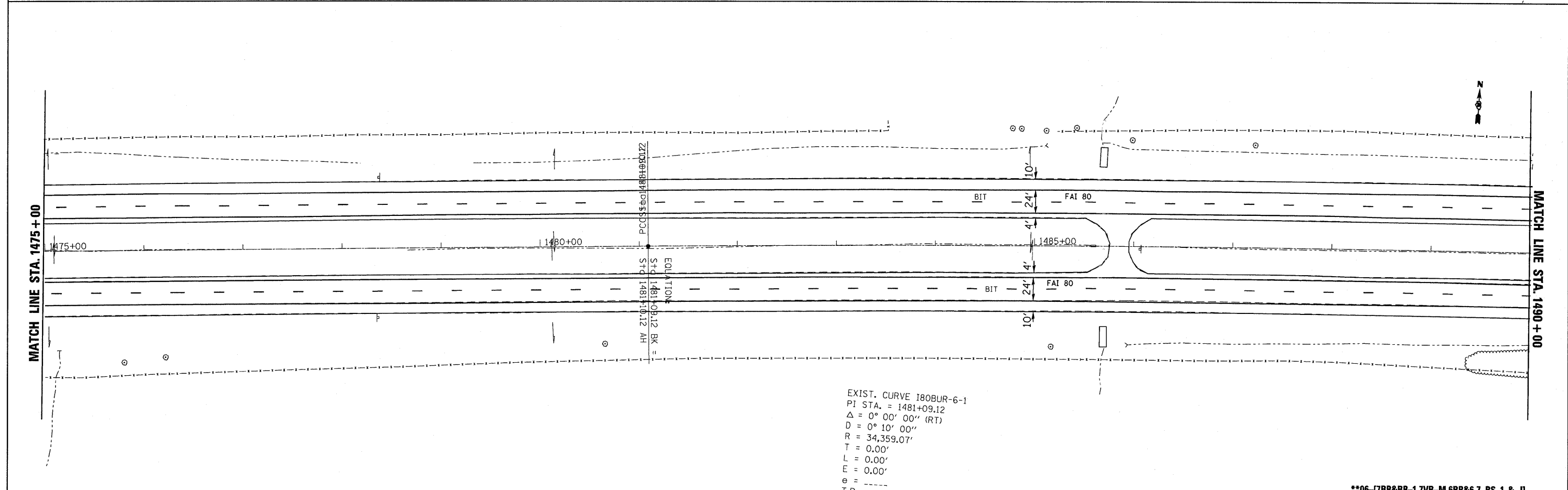
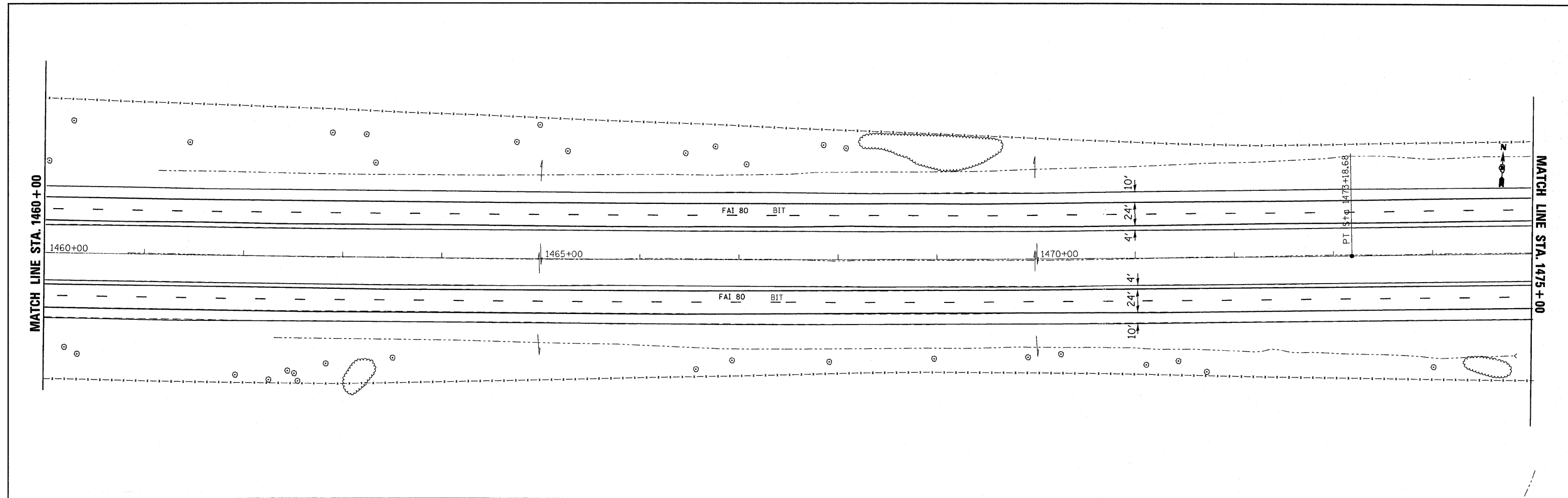

EXIST. CURVE 180BUR-6-1  
 PI STA. = 1481+09.12  
 $\Delta = 0^\circ 00' 00''$  (RT)  
 $D = 0^\circ 10' 00''$   
 $R = 34,359.07'$   
 $T = 0.00'$   
 $L = 0.00'$   
 $E = 0.00'$   
 $e =$   
 $T.R. =$

FILE NAME =	USER NAME = braboygo	DESIGNED -	REVISED -
at:\pwork\pwork\braboygo\d0112640\d368908-sht-pln.dgn		DRAWN -	REVISED -
	PLOT SCALE = 50.0000' / IN.	CHECKED -	REVISED -
	PLOT DATE = Sep 07, 2009 - 01:26:04 PM	DATE -	REVISED -

**STATE OF ILLINOIS  
 DEPARTMENT OF TRANSPORTATION**

**PLANS SHEETS STA 1460+00 TO STA 1490+00**

SCALE: \_\_\_\_\_ SHEET NO. \_\_\_\_ OF \_\_\_\_ SHEETS STA. \_\_\_\_\_ TO STA. \_\_\_\_\_

\*\*06-[7BR&BR-1,7VB-M,6BR&6,7 RS-1 & I]

F.A. RTE.	SECTION	COUNTY	TOTAL SHEETS	SHEET NO.
1-80	**	BUREAU	344	33
CONTRACT NO. 66908			ILLINOIS FED. AID PROJECT	

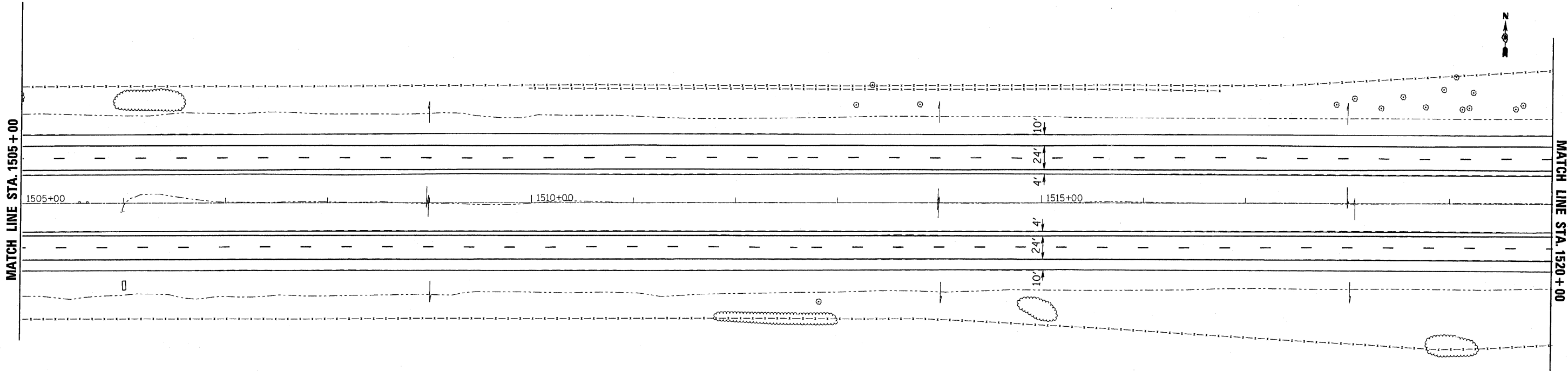
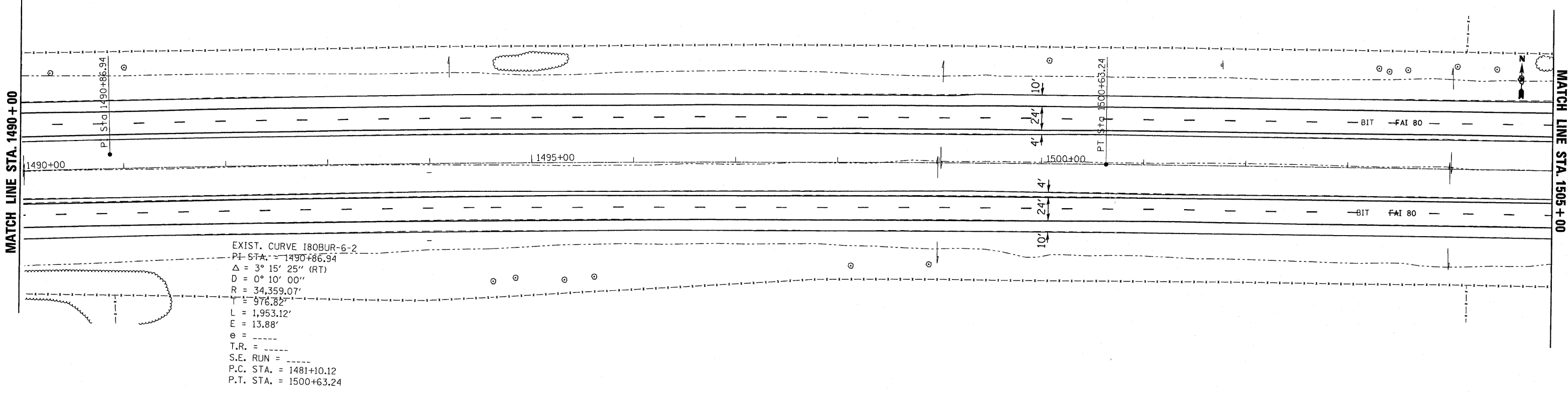

\*\*06-[7BR&BR-1,7VB-M,6BR&6,7 RS-1 & I]

FILE NAME =	USER NAME = braboyco	DESIGNED -	REVISED -
c:\pwwork\pwwork\braboyco\d0112640\d36908-ahs-plan.dgn		DRAWN -	REVISED -
PLOT SCALE = 50.0000' / IN.		CHECKED -	REVISED -
PLOT DATE = Sep 07, 2009 - 01:25:56 PM		DATE -	REVISED -

STATE OF ILLINOIS  
DEPARTMENT OF TRANSPORTATION

PLANS SHEETS STA 1490+00 TO STA 1520+00

SCALE: \_\_\_\_\_ SHEET NO. \_\_\_\_ OF \_\_\_\_ SHEETS STA. \_\_\_\_\_ TO STA. \_\_\_\_\_

F.A. RTE.	SECTION	COUNTY	TOTAL SHEETS	SHEET NO.
I-80	**	BUREAU	344	34
			CONTRACT NO. 66908	
ILLINOIS FED. AID PROJECT				

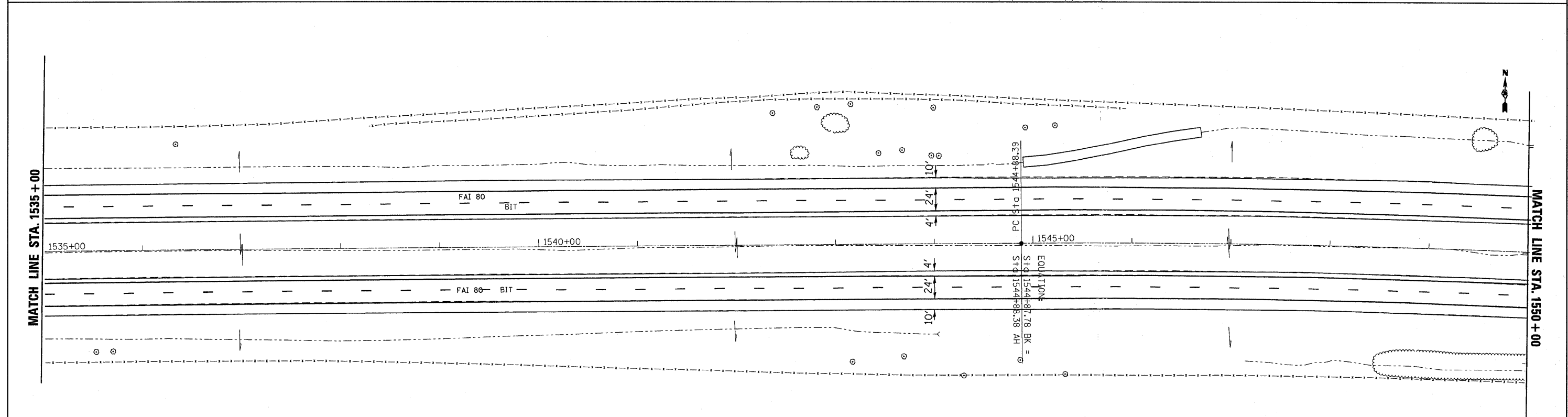
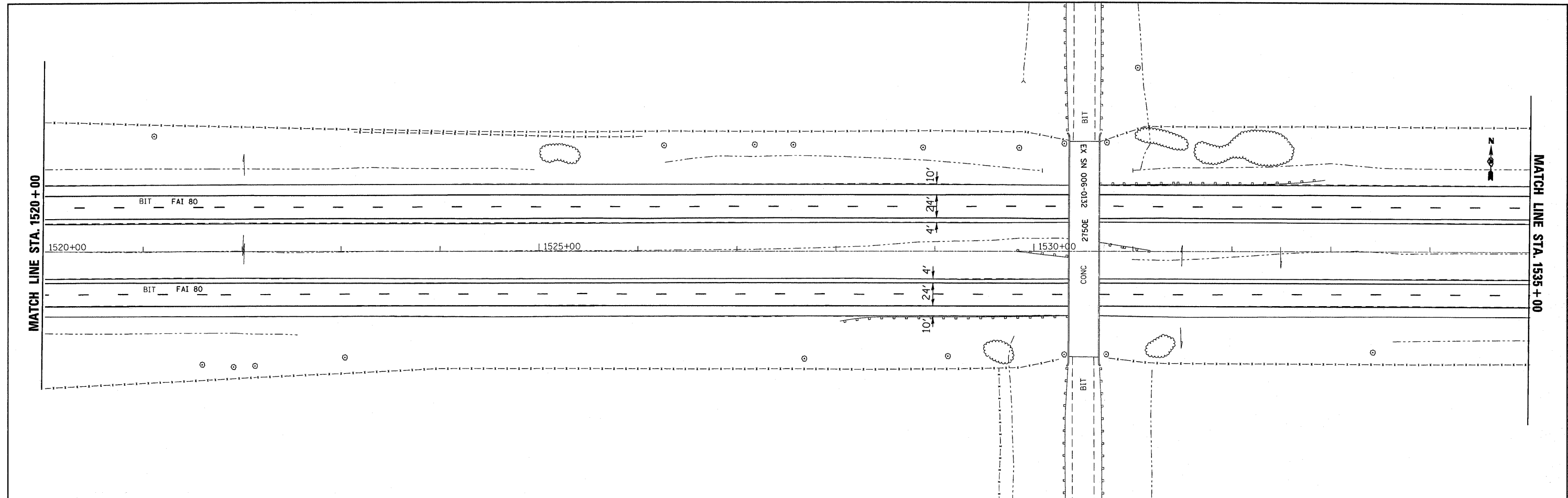

\*\*06-[7BR&BR-1,7VB-M,6BR&6,7 RS-1 & I]

FILE NAME =	USER NAME = braboypc	DESIGNED -	REVISED -
c:\pwwork\pwwork\braboypc\d0112640\d368908-sht-plan.dgn		DRAWN -	REVISED -
	PLOT SCALE = 50.0000' / IN.	CHECKED -	REVISED -
	PLOT DATE = Sep 07, 2009 - 01:25:47 PM	DATE -	REVISED -

**STATE OF ILLINOIS  
DEPARTMENT OF TRANSPORTATION**

**PLANS SHEETS STA 1520+00 TO STA 1550+00**

SCALE: \_\_\_\_\_ SHEET NO. \_\_\_ OF \_\_\_ SHEETS STA. \_\_\_\_\_ TO STA. \_\_\_\_\_

F.A. RTE. I-80	SECTION **	COUNTY BUREAU	TOTAL SHEETS 344	SHEET NO. 35
CONTRACT NO. 66908			ILLINOIS FED. AID PROJECT	

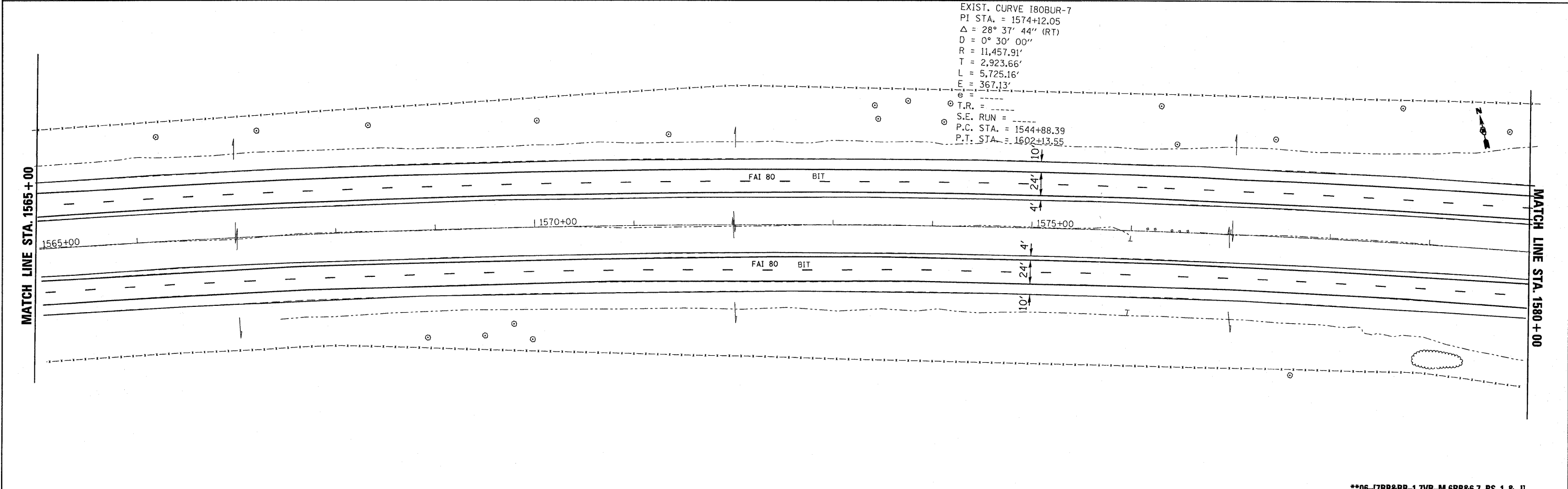
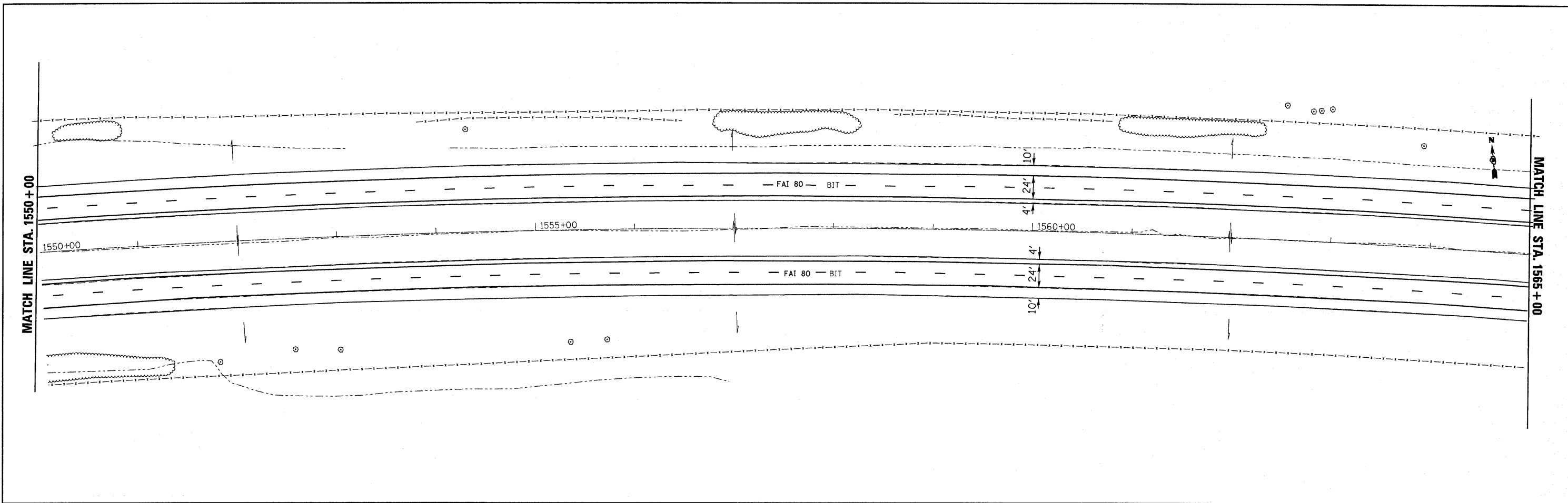

\*\*06-[7BR&BR-1,7VB-M,6BR&6,7 RS-1 & I]

FILE NAME =	USER NAME = braboypc	DESIGNED -	REVISED -
c:\pwwork\pwwork\braboypc\d0112640\d368908-sht-plan.dgn		DRAWN -	REVISED -
	PLOT SCALE = 50.0000' / IN.	CHECKED -	REVISED -
	PLOT DATE = Sep 07, 2009 - 01:25:35 PM	DATE -	REVISED -

STATE OF ILLINOIS  
DEPARTMENT OF TRANSPORTATION

PLANS SHEETS STA 1550+00 TO STA 1580+00

SCALE: SHEET NO. OF SHEETS STA. TO STA.

F.A. RTE.	SECTION	COUNTY	TOTAL SHEETS	SHEET NO.
I-80	**	BUREAU	344	36
CONTRACT NO. 66908			ILLINOIS FED. AID PROJECT	

MATCH LINE STA. 1425+00

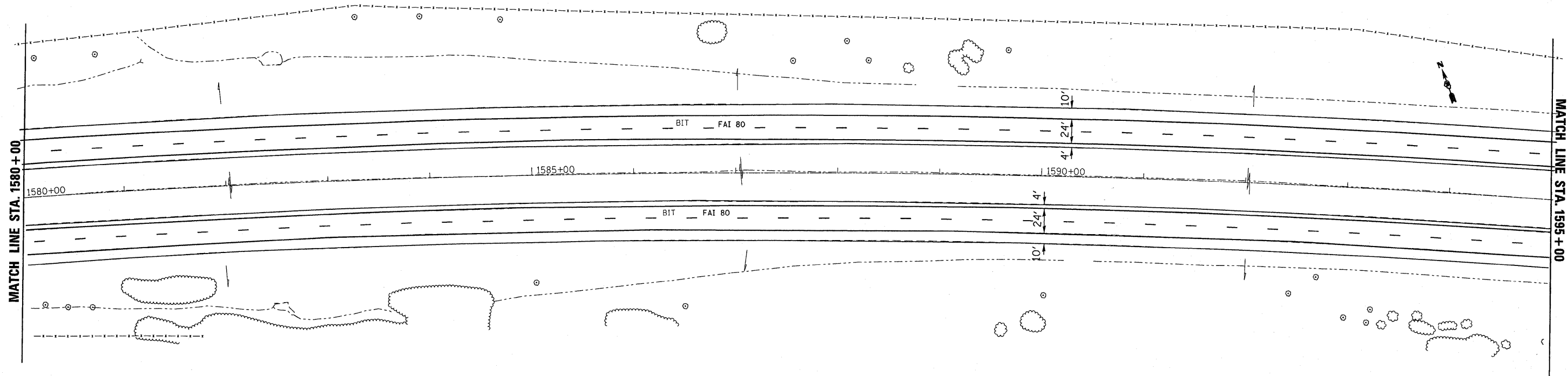

MATCH LINE STA. 1595+00

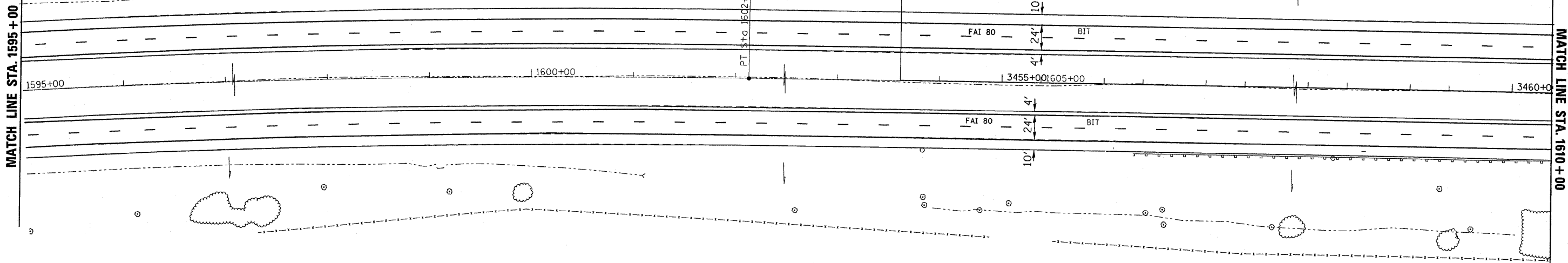

MATCH LINE STA. 1610+00

\*NOTE-SEPERATE SHEETS DRAWN SHOWING BRIDGE WORK AND ROADWAY WORK WERE DEVELOPED USING OLD STATIONING

\*\*06-[7BR&BR-1,7VB-M,6BR&6,7 RS-1 & I]

FILE NAME =	USER NAME = braboyco	DESIGNED -	REVISED -
c:\pwork\pwork\braboyco\d0112640\d368908-sht-plan.dgn		DRAWN -	REVISED -
	PLOT SCALE = 50.0000 / IN.	CHECKED -	REVISED -
	PLOT DATE = Sep 07, 2009 - 01:26:27 PM	DATE -	REVISED -

STATE OF ILLINOIS  
DEPARTMENT OF TRANSPORTATION

PLANS SHEETS STA 1580+00 TO STA 1610+00

SCALE: \_\_\_\_\_ SHEET NO. \_\_\_\_ OF \_\_\_\_ SHEETS STA. \_\_\_\_\_ TO STA. \_\_\_\_\_

F.A. RTE.	SECTION	COUNTY	TOTAL SHEETS	SHEET NO.
1-80	**	BUREAU	344	37
CONTRACT NO. 66908			ILLINOIS FED. AID PROJECT	

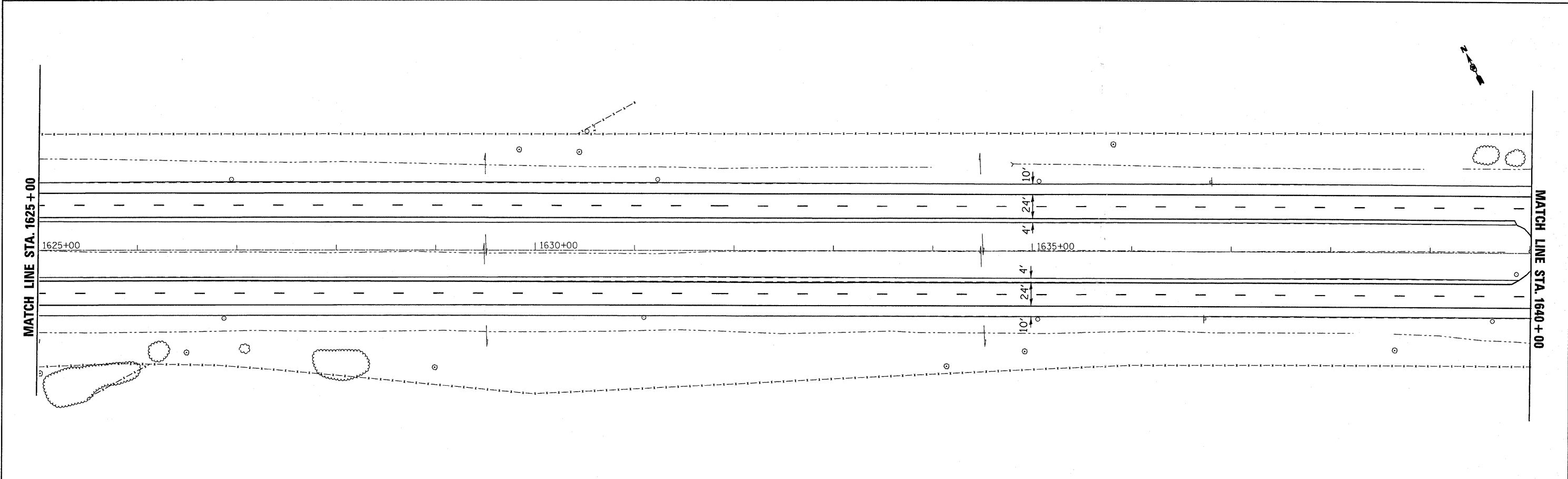
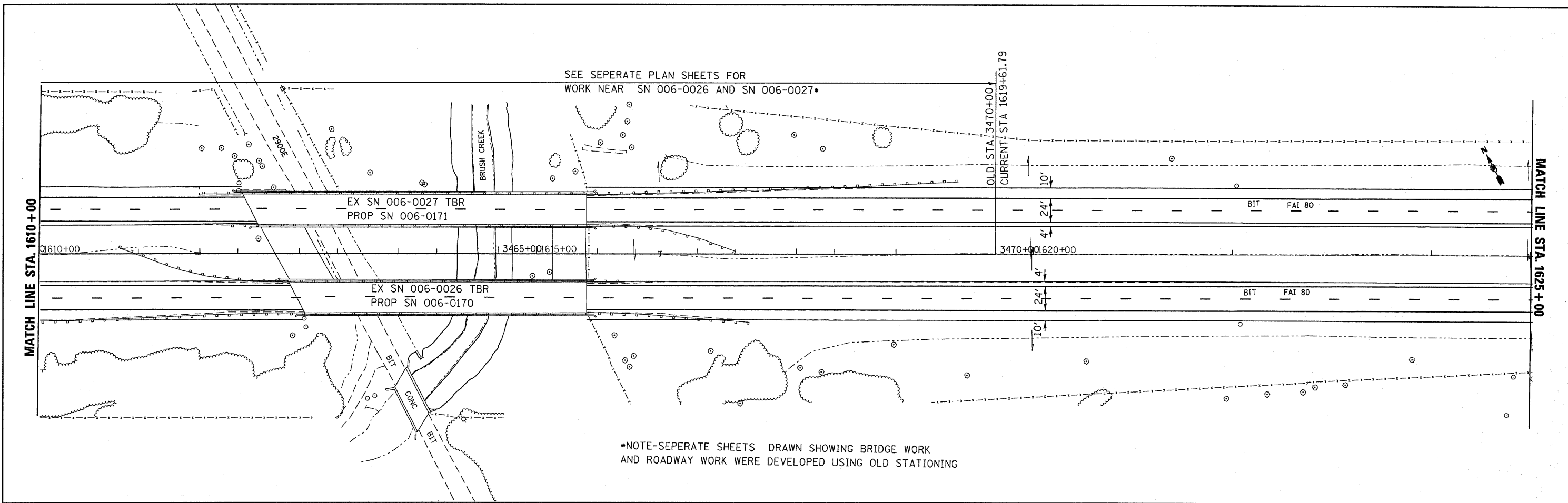

FILE NAME =				USER NAME = braboypc				DESIGNED -				REVISED -				<p align="center"><b>STATE OF ILLINOIS</b> <b>DEPARTMENT OF TRANSPORTATION</b></p> <p align="center"><b>PLANS SHEETS STA 1610+00 TO STA 1640+00</b></p> <p>SCALE: _____ SHEET NO. ___ OF ___ SHEETS STA. _____ TO STA. _____</p>				F.A. RTE. =		SECTION		COUNTY		TOTAL SHEETS		SHEET NO.	
ci:\pw_work\pw\dot\braboypc\d0112640\1368908-sht-plan.dgn				DRAWN -				REVISED -				I-80		**						BUREAU		344		38					
PLOT SCALE = 50.0000' / IN.				CHECKED -				REVISED -																					
PLOT DATE = Sep 07, 2009 - 01:25:19 PM				DATE -				REVISED -																					
												<p align="right">**06-[7BR&amp;BR-1,7VB-M,6BR&amp;6,7 RS-1 &amp; I]</p> <p align="right">ILLINOIS FED. AID PROJECT</p>																	

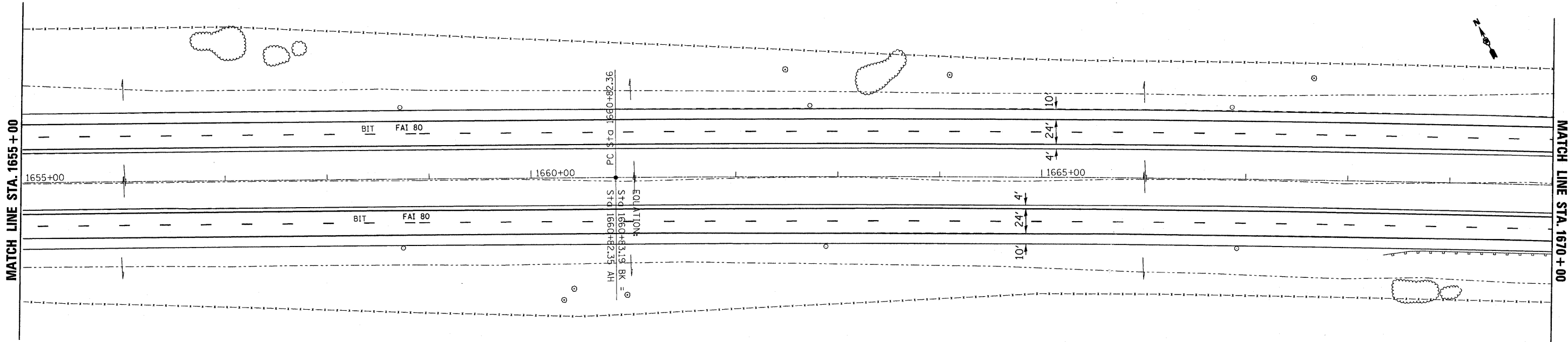
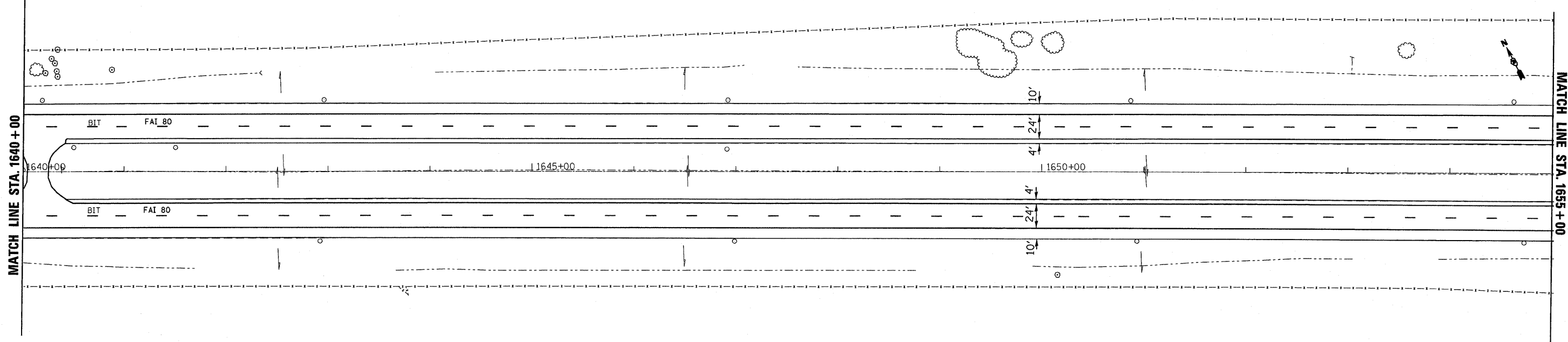

\*\*06-[7BR&BR-1,7VB-M,6BR&6,7 RS-1 & I]

FILE NAME =	USER NAME = braboyce	DESIGNED -	REVISED -
c:\pwwork\pwwork\braboyce\d0112640\1368900-ah.t-plan.dgn		DRAWN -	REVISED -
	PLOT SCALE = 50.0000 / IN.	CHECKED -	REVISED -
	PLOT DATE = Sep 07, 2009 - 01:25:07 PM	DATE -	REVISED -

**STATE OF ILLINOIS  
DEPARTMENT OF TRANSPORTATION**

**PLANS SHEETS STA 1640+00 TO STA 1670+00**

SCALE: \_\_\_\_\_ SHEET NO. \_\_\_ OF \_\_\_ SHEETS STA. \_\_\_\_\_ TO STA. \_\_\_\_\_

F.A. RTE. I-80	SECTION **	COUNTY BUREAU	TOTAL SHEETS 344	SHEET NO. 39
CONTRACT NO. 66908			ILLINOIS FED. AID PROJECT	

EXIST. CURVE I80BUR-8  
 PI STA. = 1682+68.04  
 $\Delta = 7^{\circ} 17' 03''$  (RT)  
 $D = 0^{\circ} 10' 01''$   
 $R = 34,338.38'$   
 $T = 2,185.68'$   
 $L = 4,365.47'$   
 $E = 69.49'$   
 T.P. =  
 S.E. RUN =  
 P.O. STA. = 1660+82.36  
 P.T. STA. = 1704+47.83

PI STA 1682+68.04

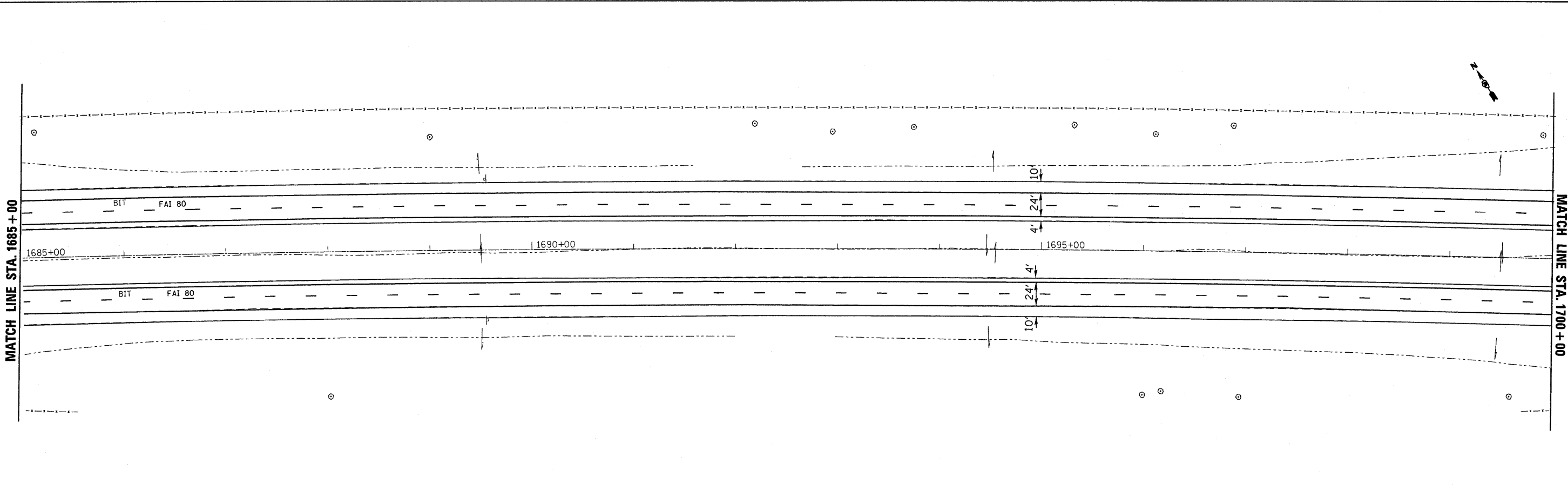
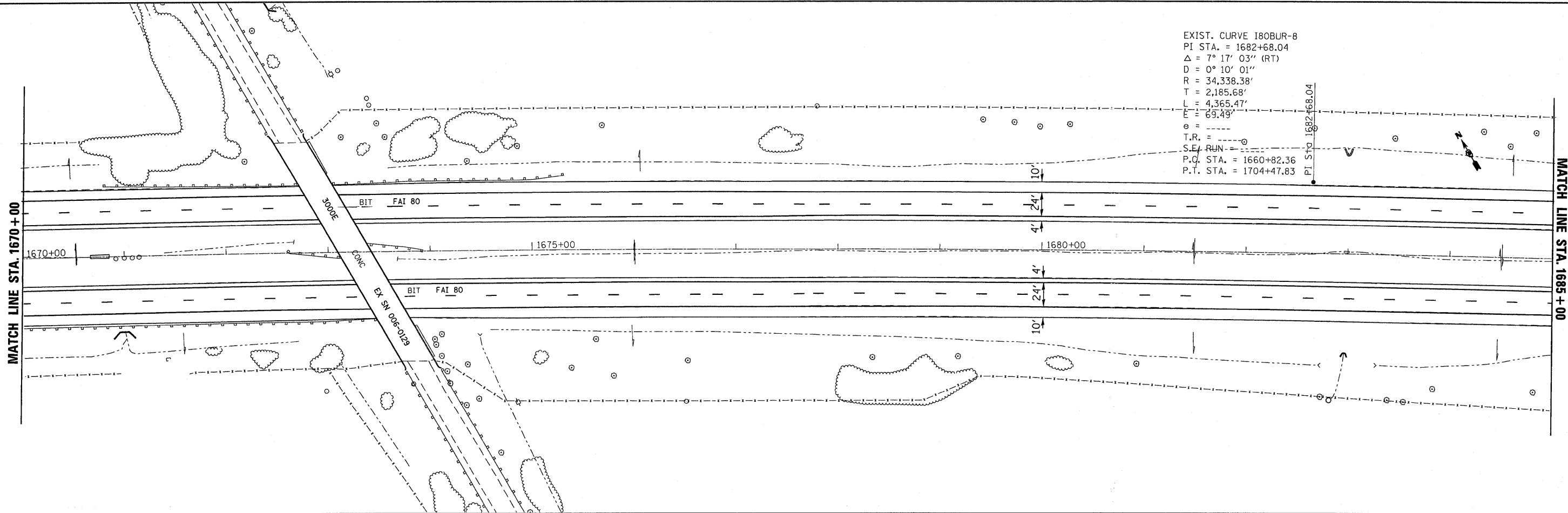

\*\*06-[7BR&BR-1,7VB-M,6BR&6,7 RS-1 & I]

FILE NAME =	USER NAME = braboygo	DESIGNED -	REVISED -
c:\pwwork\pwwork\braboygo\d0112640\d368908-sht-plan.dgn		DRAWN -	REVISED -
	PLOT SCALE = 50.0000' / IN.	CHECKED -	REVISED -
	PLOT DATE = Sep 07, 2009 - 01:24:59 PM	DATE -	REVISED -

**STATE OF ILLINOIS  
 DEPARTMENT OF TRANSPORTATION**

**PLANS SHEETS STA 1670+00 TO STA 1700+00**

SCALE: \_\_\_\_\_ SHEET NO. \_\_\_ OF \_\_\_ SHEETS STA. \_\_\_\_\_ TO STA. \_\_\_\_\_

F.A. RTE.	SECTION	COUNTY	TOTAL SHEETS	SHEET NO.
I-80	**	BUREAU	344	40
CONTRACT NO. 66908			ILLINOIS FED. AID PROJECT	



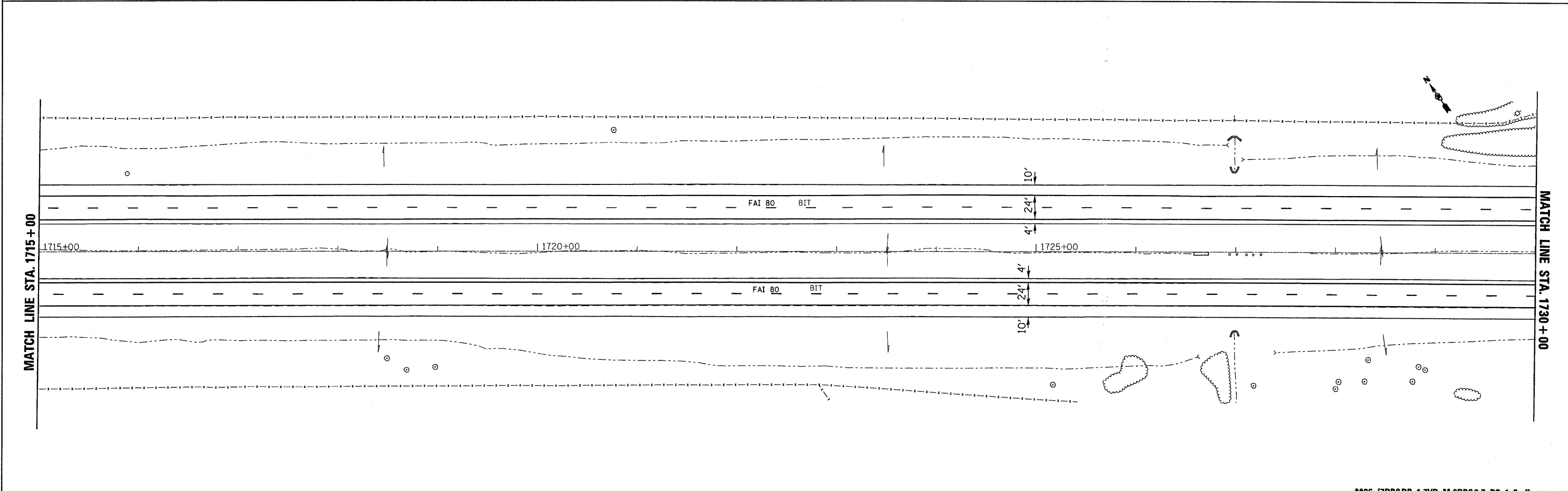
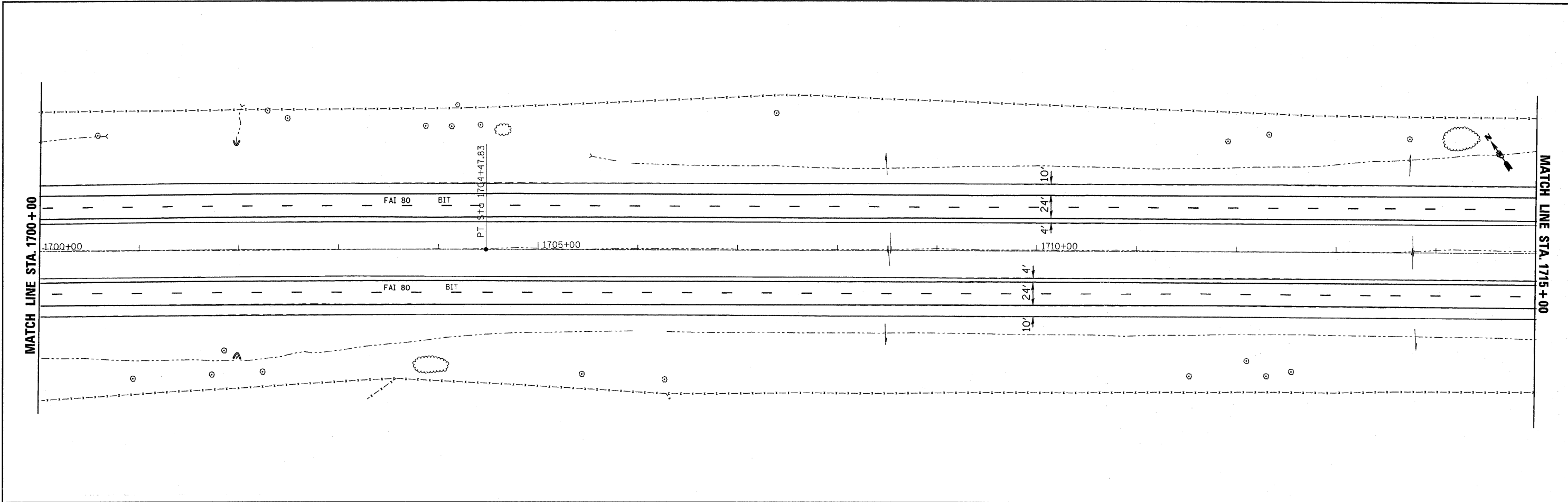

FILE NAME =	USER NAME = braboypc	DESIGNED -	REVISED -
c:\pwork\pwidot\braboypc\d0112640\d368908-sht-plan.dgn		DRAWN -	REVISED -
	PLOT SCALE = 50.0000 / IN.	CHECKED -	REVISED -
	PLOT DATE = Sep 07, 2009 - 01:24:51 PM	DATE -	REVISED -

**STATE OF ILLINOIS  
DEPARTMENT OF TRANSPORTATION**

**PLANS SHEETS STA 1700+00 TO STA 1730+00**

SCALE: \_\_\_\_\_ SHEET NO. \_\_\_ OF \_\_\_ SHEETS STA. \_\_\_\_\_ TO STA. \_\_\_\_\_

F.A. RTE. I-80	SECTION **	COUNTY BUREAU	TOTAL SHEETS 344	SHEET NO. 41
CONTRACT NO. 66908			ILLINOIS FED. AID PROJECT	

\*\*06-[7BR&BR-1,7VB-M,6BR&6,7 RS-1 & I]

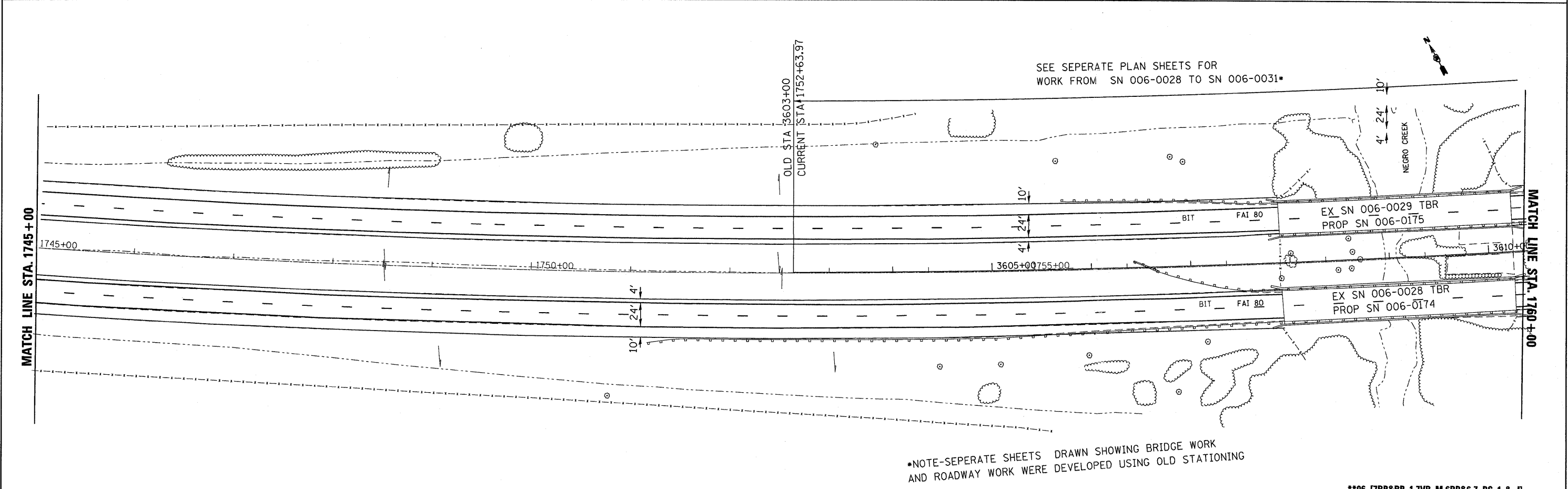
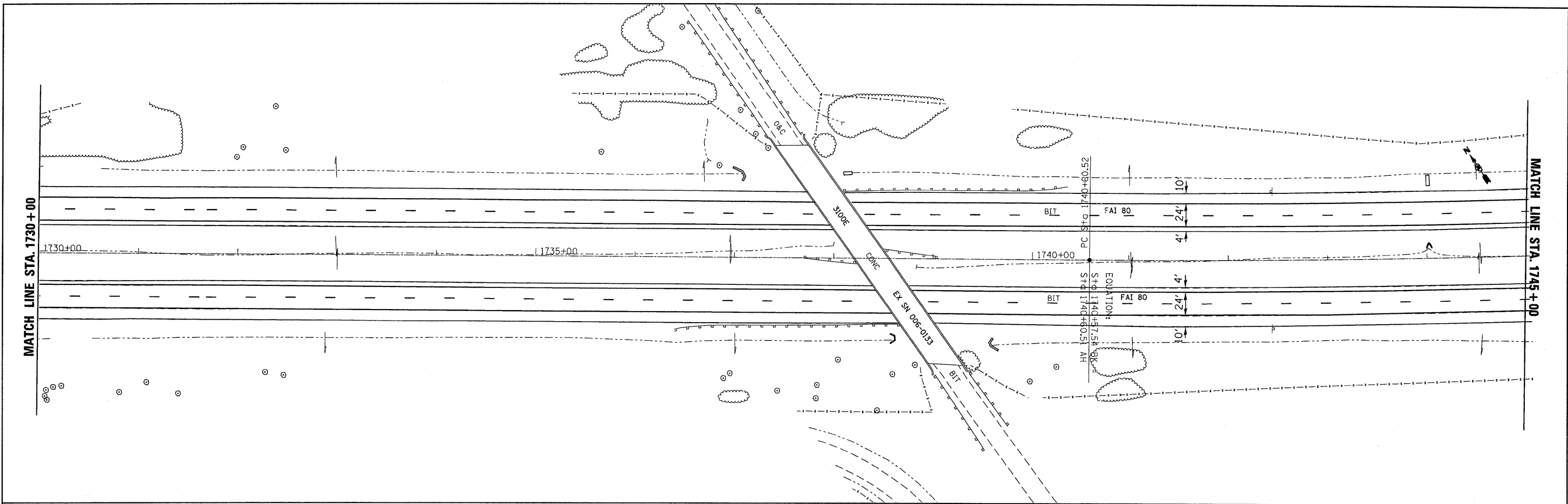

SEE SEPERATE PLAN SHEETS FOR  
WORK FROM SN 006-0028 TO SN 006-0031\*

\*NOTE-SEPERATE SHEETS DRAWN SHOWING BRIDGE WORK  
AND ROADWAY WORK WERE DEVELOPED USING OLD STATIONING

FILE NAME =	USER NAME = braboypc	DESIGNED -	REVISED -
c:\pwork\pwork\braboypc\d8112640\d368908-sht-plan.dgn		DRAWN -	REVISED -
PLOT SCALE = 50.0000' / IN.		CHECKED -	REVISED -
PLOT DATE = Sep 07, 2009 - 01:24:41 PM		DATE -	REVISED -

**STATE OF ILLINOIS  
DEPARTMENT OF TRANSPORTATION**

**PLANS SHEETS STA 1730+00 TO STA 1760+00**

SCALE: \_\_\_\_\_ SHEET NO. \_\_\_ OF \_\_\_ SHEETS STA. \_\_\_\_\_ TO STA. \_\_\_\_\_

**\*\*06-[7BR&BR-1,7VB-M,6BR&6,7 RS-1 & I]**

F.A. RTE.	SECTION	COUNTY	TOTAL SHEETS	SHEET NO.
I-80	**	BUREAU	344	42
CONTRACT NO. 66908			ILLINOIS FED. AID PROJECT	

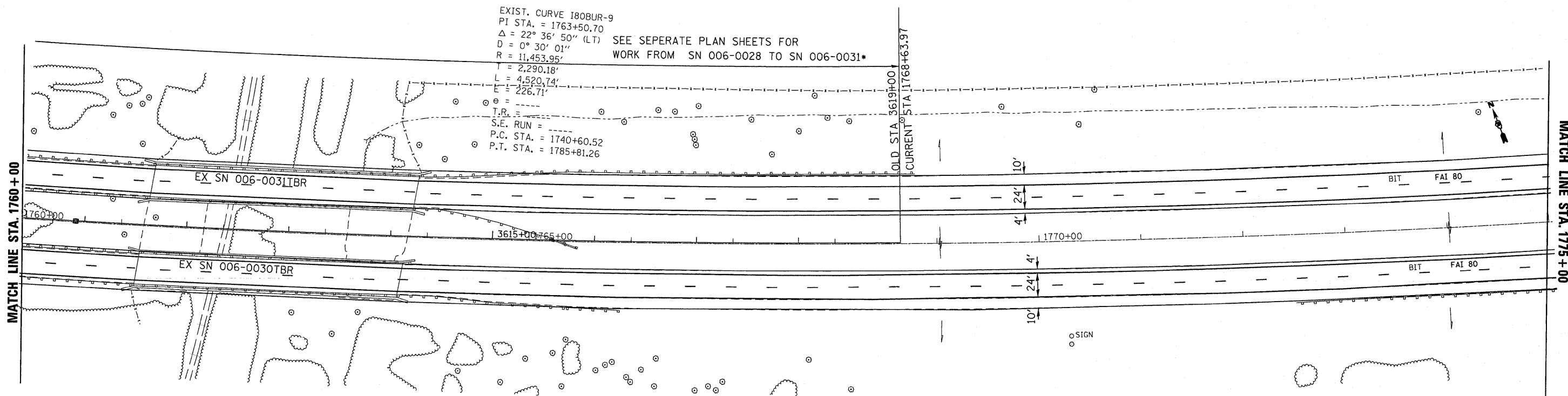

\*NOTE-SEPERATE SHEETS DRAWN SHOWING BRIDGE WORK AND ROADWAY WORK WERE DEVELOPED USING OLD STATIONING

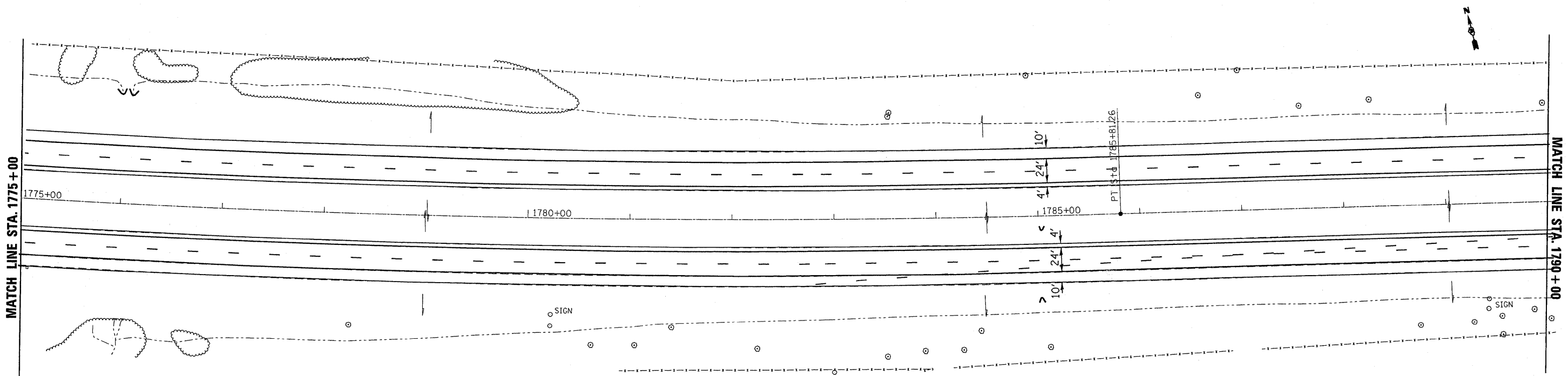

FILE NAME =	USER NAME = bbraygo	DESIGNED -	REVISED -
c:\pwork\pwork\dot\braygo\10112640\1368908-sht-plan.dgn		DRAWN -	REVISED -
PLOT SCALE = 50.0000 / IN.		CHECKED -	REVISED -
PLOT DATE = Sep 07, 2009 - 01:24:31 PM		DATE -	REVISED -

STATE OF ILLINOIS  
DEPARTMENT OF TRANSPORTATION

PLANS SHEETS STA 1760+00 TO STA 1790+00

SCALE: \_\_\_\_\_ SHEET NO. \_\_\_ OF \_\_\_ SHEETS STA. \_\_\_\_\_ TO STA. \_\_\_\_\_

\*\*06-[7BR&BR-1,7VB-M,6BR&6,7 RS-1 & I]

F.A. RTE.	SECTION	COUNTY	TOTAL SHEETS	SHEET NO.
I-80	**	BUREAU	344	43
CONTRACT NO. 66908			ILLINOIS FED. AID PROJECT	

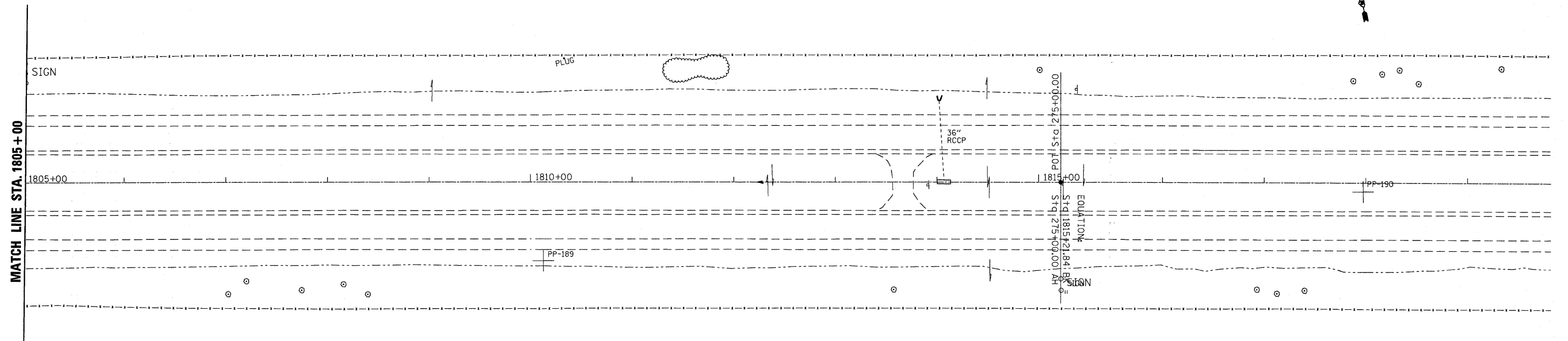
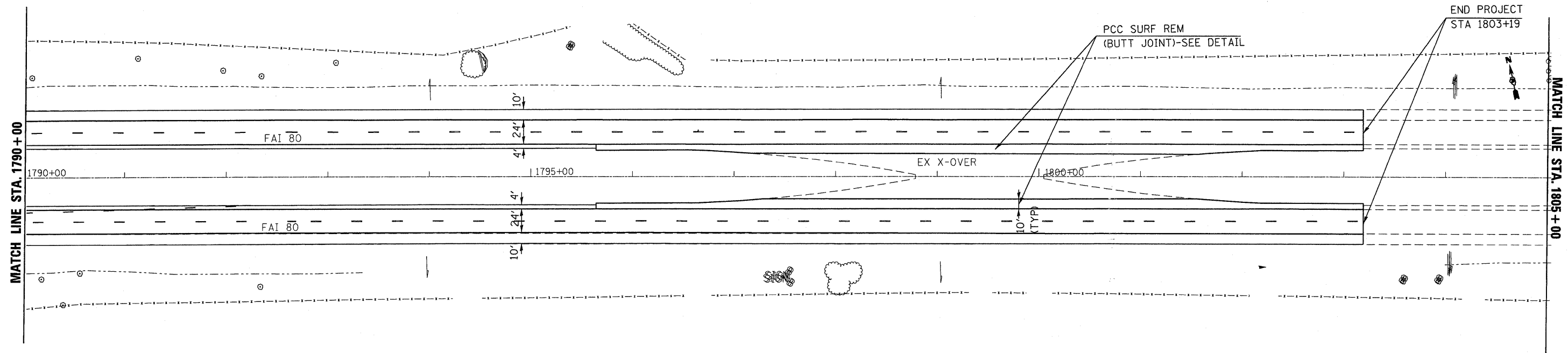

FILE NAME =	USER NAME = breboypc	DESIGNED -	REVISED -
c:\pwwork\pwwork\breboypc\d0112640\d368908-sht-plan.dgn		DRAWN -	REVISED -
	PLOT SCALE = 50.0000' / IN.	CHECKED -	REVISED -
	PLOT DATE = Sep 07, 2009 - 01:24:25 PM	DATE -	REVISED -

**STATE OF ILLINOIS  
DEPARTMENT OF TRANSPORTATION**

**PLANS SHEETS STA 1790+00 TO STA 1815+00**

SCALE: \_\_\_\_\_ SHEET NO. \_\_\_ OF \_\_\_ SHEETS STA. \_\_\_\_\_ TO STA. \_\_\_\_\_

\*\*06-[7BR&BR-1,7VB-M,6BR&6,7 RS-1 & I]

F.A. RTE. I-80	SECTION **	COUNTY BUREAU	TOTAL SHEETS 344	SHEET NO. 44
			CONTRACT NO. 66908	
ILLINOIS FED. AID PROJECT				

**NOTES:**

1. MAINLINE RESURFACING, 1 3/4" INCLUDES: 1 3/4" POLYMERIZED HOT-MIX ASPHALT SURFACE COURSE, MIX "D", N105
2. POLYMERIZED LEVELING BINDER (MACHINE METHOD), N90 (3/4" MIN. VARIABLE DEPTH) (AS NECESSARY)
3. SHOULDER RESURFACING, 1 3/4" INCLUDES: 1 3/4" HOT-MIX ASPHALT SURFACE COURSE, MIX "C", N50
- 3A. SHOULDER RESURFACING, 1 3/4" INCLUDES: 1 3/4" POLYMERIZED HOT-MIX ASPHALT SURFACE COURSE, MIX "D", N105
4. FULL-DEPTH HOT-MIX ASPHALT SHOULDERS, 12" INCLUDES: 1 3/4" HOT-MIX ASPHALT SURFACE COURSE, MIX "C", N50 10 1/4" HOT-MIX ASPHALT BINDER COURSE, IL-19.0, N50 6" AGGREGATE BASE COURSE, TYPE A
- 4A. FULL-DEPTH HOT-MIX ASPHALT SHOULDERS, 12" INCLUDES: 1 3/4" POLYMERIZED HOT-MIX ASPHALT SURFACE COURSE, MIX "D", N105 10 1/4" HOT-MIX ASPHALT BINDER COURSE, IL-19.0, N90 6" AGGREGATE BASE COURSE, TYPE A
5. SEE ROADWAY DETAILS SHEET FOR TABLE OF STATIONS/OFFSETS

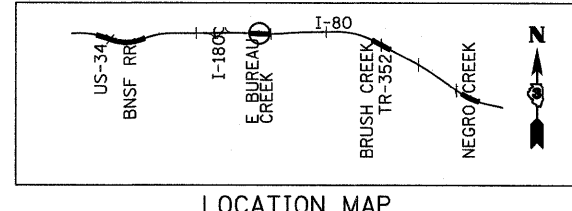
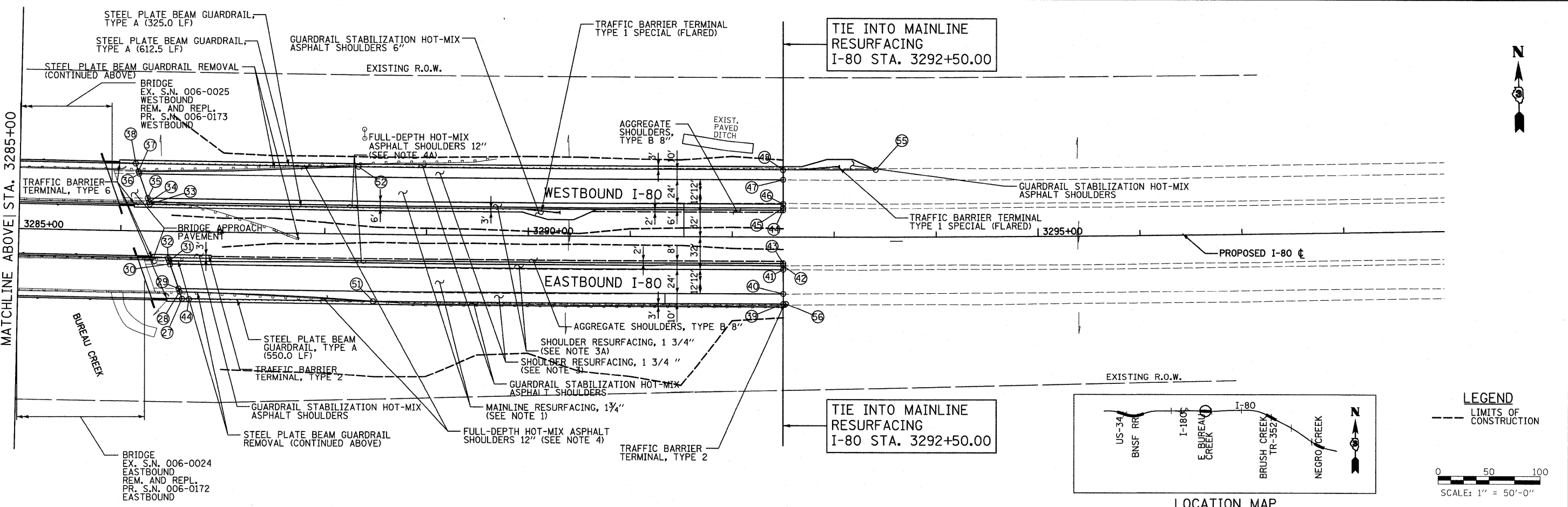
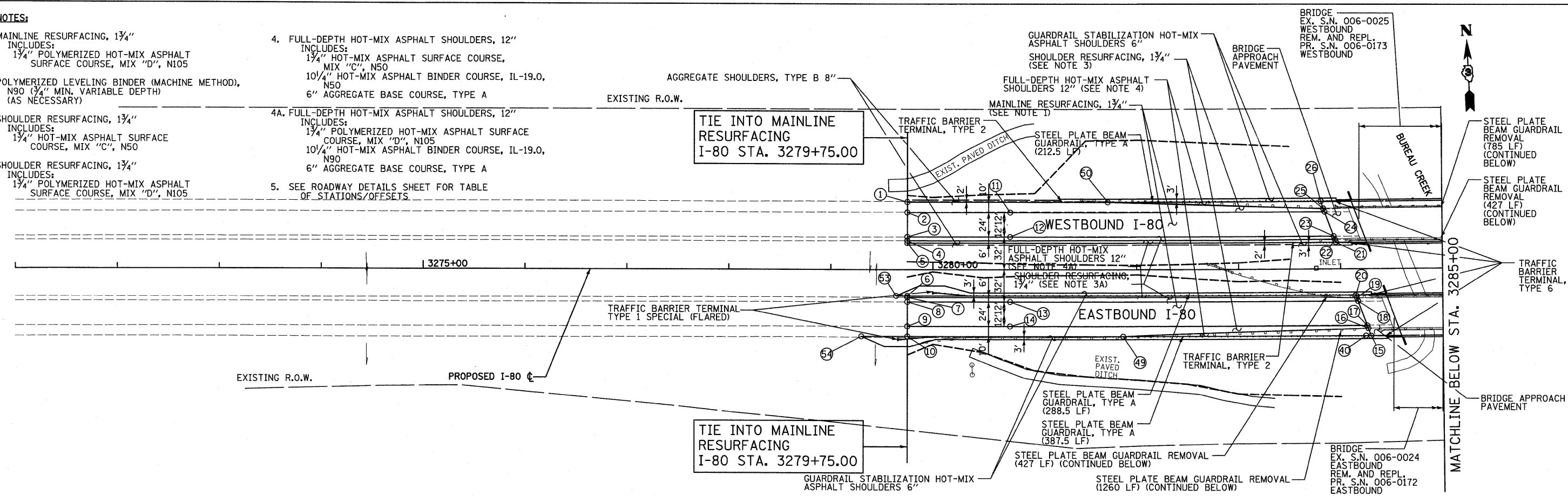

**LEGEND**  
 --- LIMITS OF CONSTRUCTION  
 0 50 100  
 SCALE: 1" = 50'-0"

<b>TYLIN INTERNATIONAL</b>	USER NAME = #USER#	DESIGNED - CAC	REVISED -
	PLOT SCALE = #SCALE#	DRAWN - CAC	REVISED -
	PLOT DATE = 8/14/2009	CHECKED - JDF	REVISED -
		DATE - 08/14/2009	REVISED -

**STATE OF ILLINOIS  
 DEPARTMENT OF TRANSPORTATION**

<b>F.A.I. ROUTE 80 (I-80) PROPOSED PLANS</b>	
SCALE: 1" = 50'	SHEET NO. 1 OF 1 SHEET
STA. 3279+75 TO STA. 3292+50	

F.A.I. RTE. 80	SECTION	COUNTY	TOTAL SHEETS NO.	SHEET NO.
		BUREAU	344	45
CONTRACT NO. 66908				

PLAN VIEW STATION/OFFSET CALLOUTS

POINT NUMBER	POINT DESCRIPTION	STATION	OFFSET
1	BACK OF SHOULDER - PROJECT LIMIT	3279+75.00	66.00' LT
2	EOP - PROJECT LIMIT	3279+75.00	56.00' LT
3	EOP - PROJECT LIMIT	3279+75.00	32.00' LT
4	BACK OF SHOULDER RESURFACE - PROJECT LIMIT	3279+75.00	28.50' LT
5	BACK OF SHOULDER FULL-DEPTH - PROJECT LIMIT	3279+75.00	26.00' LT
6	BACK OF SHOULDER FULL-DEPTH - PROJECT LIMIT	3279+75.00	26.00' RT
7	BACK OF SHOULDER RESURFACE - PROJECT LIMIT	3279+75.00	27.52' RT
8	EOP - PROJECT LIMIT	3279+75.00	32.00' RT
9	EOP - PROJECT LIMIT	3279+75.00	56.00' RT
10	BACK OF SHOULDER - PROJECT LIMIT	3279+75.00	66.00' RT
11	EOP - PC	3280+75.81	56.00' LT
12	EOP - PC	3280+75.81	32.00' LT
13	EOP - PC	3280+75.81	32.00' RT
14	EOP - PC	3280+75.81	56.00' RT
15	BACK OF SHOULDER FULL-DEPTH - APPROACH PVMT LIMIT	3284+29.53	66.00' RT
16	BACK OF SHOULDER RESURFACE - APPROACH PVMT LIMIT	3284+26.83	58.77' RT
17	EOP - APPROACH PVMT LIMIT	3284+25.82	56.00' RT
18	EOP - APPROACH PVMT LIMIT	3284+16.99	32.00' RT
19	BACK OF SHOULDER RESURFACE - APPROACH PVMT LIMIT	3284+15.81	28.79' RT
20	BACK OF SHOULDER FULL-DEPTH - APPROACH PVMT LIMIT	3284+14.83	26.12' RT
21	BACK OF SHOULDER FULL-DEPTH - APPROACH PVMT LIMIT	3283+95.58	25.81' LT
22	BACK OF SHOULDER RESURFACE - APPROACH PVMT LIMIT	3283+81.02	28.72' LT
23	EOP - APPROACH PVMT LIMIT	3283+93.29	32.00' LT
24	EOP - APPROACH PVMT LIMIT	3283+84.38	56.00' LT
25	BACK OF SHOULDER RESURFACE - APPROACH PVMT LIMIT	3283+83.25	59.07' LT
26	BACK OF SHOULDER FULL-DEPTH - APPROACH PVMT LIMIT	3283+80.77	65.76' LT
27	BACK OF SHOULDER FULL-DEPTH - APPROACH PVMT LIMIT	3286+61.23	66.24' RT
28	BACK OF SHOULDER RESURFACE - APPROACH PVMT LIMIT	3286+58.71	59.27' RT

PLAN VIEW STATION/OFFSET CALLOUTS

POINT NUMBER	POINT DESCRIPTION	STATION	OFFSET
29	EOP - APPROACH PVMT LIMIT	3286+57.53	56.00' RT
30	EOP - APPROACH PVMT LIMIT	3286+48.86	32.00' RT
31	BACK OF SHOULDER RESURFACE - APPROACH PVMT LIMIT	3286+47.90	29.34' RT
32	BACK OF SHOULDER FULL-DEPTH - APPROACH PVMT LIMIT	3286+46.76	26.19' RT
33	BACK OF SHOULDER FULL-DEPTH - APPROACH PVMT LIMIT	3286+27.98	26.00' LT
34	BACK OF SHOULDER RESURFACE - APPROACH PVMT LIMIT	3286+27.25	28.02' LT
35	EOP - APPROACH PVMT LIMIT	3286+25.81	32.00' LT
36	EOP - APPROACH PVMT LIMIT	3286+17.14	56.00' LT
37	BACK OF SHOULDER RESURFACE - APPROACH PVMT LIMIT	3286+16.29	58.34' LT
38	BACK OF SHOULDER FULL-DEPTH - APPROACH PVMT LIMIT	3286+13.56	66.00' LT
39	BACK OF SHOULDER - PROJECT LIMIT	3292+50.00	66.00' RT
40	EOP - PROJECT LIMIT	3292+50.00	56.00' RT
41	EOP - PROJECT LIMIT	3292+50.00	32.00' RT
42	BACK OF SHOULDER RESURFACE - PROJECT LIMIT	3292+50.00	28.15' RT
43	BACK OF SHOULDER FULL-DEPTH - PROJECT LIMIT	3292+50.00	26.00' RT
44	BACK OF SHOULDER FULL-DEPTH - PROJECT LIMIT	3292+50.00	26.00' LT
45	BACK OF SHOULDER RESURFACE - PROJECT LIMIT	3292+50.00	28.22' LT
46	EOP - PROJECT LIMIT	3292+50.00	32.00' LT
47	EOP - PROJECT LIMIT	3292+50.00	56.00' LT
48	BACK OF SHOULDER - PROJECT LIMIT	3292+50.00	66.00' LT
49	BEGIN FULL-DEPTH OUTSIDE SHOULDER	3281+86.51	66.00' RT
50	BEGIN FULL-DEPTH OUTSIDE SHOULDER	3281+71.67	66.00' LT
51	END FULL-DEPTH OUTSIDE SHOULDER	3288+48.11	66.00' RT
52	END FULL-DEPTH OUTSIDE SHOULDER	3288+32.46	66.00' LT
53	STABILIZATION LIMIT	3279+64.00	26.00' RT
54	STABILIZATION LIMIT	3279+29.95	66.00' RT
55	STABILIZATION LIMIT	3293+40.86	65.88' LT
56	STABILIZATION LIMIT	3292+52.73	66.00' RT

USER NAME = #USER#	DESIGNED - CAC	REVISED -	<b>STATE OF ILLINOIS DEPARTMENT OF TRANSPORTATION</b>	<b>F.A.I. ROUTE 80 (I-80) ROADWAY DETAILS SHEET</b>		F.A.I. RTE. 80	SECTION •	COUNTY BUREAU	TOTAL SHEETS 344	SHEET NO. 44
PLOT SCALE = #SCALE#	DRAWN - CAC	REVISED -		SCALE: NONE	SHEET NO. 1 OF 1 SHEETS	STA.	CONTRACT NO. 66908			
PLOT DATE = 8/14/2009	CHECKED - JDF	REVISED -				TO STA.	ILLINOIS FED. AID PROJECT			
	DATE - 08/14/2009	REVISED -						* 06-I7BR & BR-1,TVB-M, GBR & 6, 7 RS-1 & IICAC		

PROJECT NO. 06-17BR & BR-1,7VB-M, 6BR & 6, 7 RS-1 & 1  
 DRAWN BY: JDF  
 CHECKED BY: CAC  
 DATE: 08/14/2009

PROJECT NO. 06-17BR & BR-1,7VB-M, 6BR & 6, 7 RS-1 & 1  
 DRAWN BY: JDF  
 CHECKED BY: CAC  
 DATE: 08/14/2009

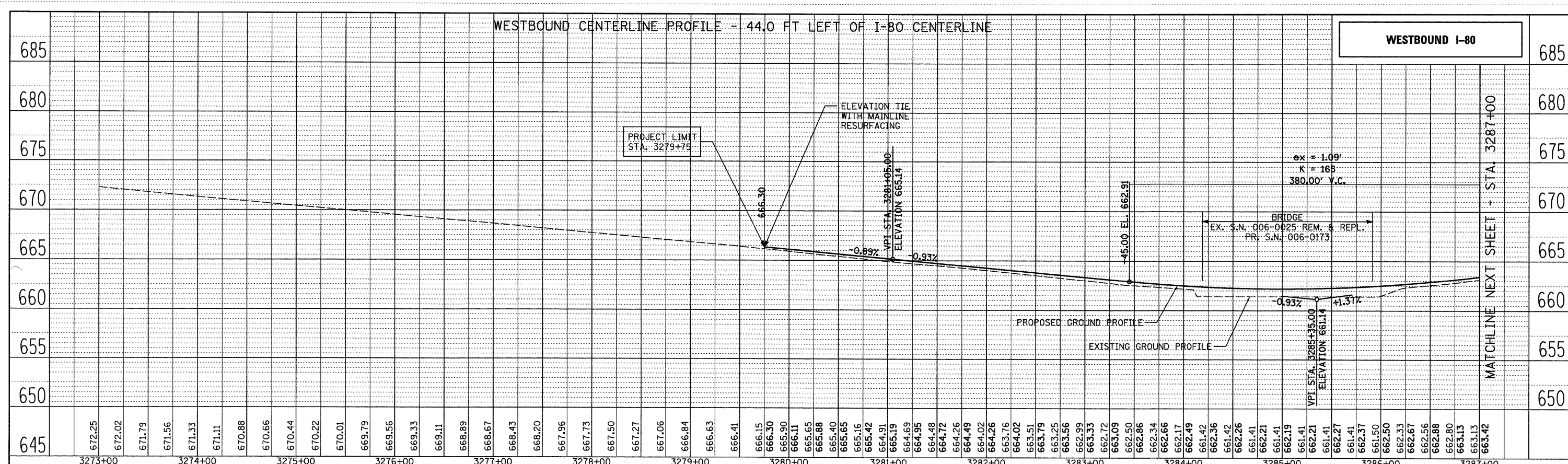

645	672.25	672.02	671.79	671.56	671.33	671.11	670.88	670.66	670.44	670.22	670.01	669.79	669.56	669.33	669.11	668.89	668.67	668.43	668.20	667.96	667.73	667.50	667.27	667.06	666.84	666.63	666.41	666.15	666.30	665.90	666.11	665.65	665.88	665.40	665.65	665.16	665.42	664.91	665.19	664.69	664.95	664.48	664.72	664.26	664.49	664.02	664.26	663.76	664.02	663.51	663.79	663.25	663.56	662.99	663.33	662.72	663.09	662.50	662.86	662.34	662.66	662.17	662.49	661.42	662.36	661.42	662.26	661.41	662.21	661.41	662.19	661.41	662.27	661.41	662.37	661.50	662.50	662.33	662.67	662.56	662.88	662.80	663.13	663.13	663.42
	3273+00		3274+00		3275+00		3276+00		3277+00		3278+00		3279+00		3280+00		3281+00		3282+00		3283+00		3284+00		3285+00		3286+00		3287+00																																																								

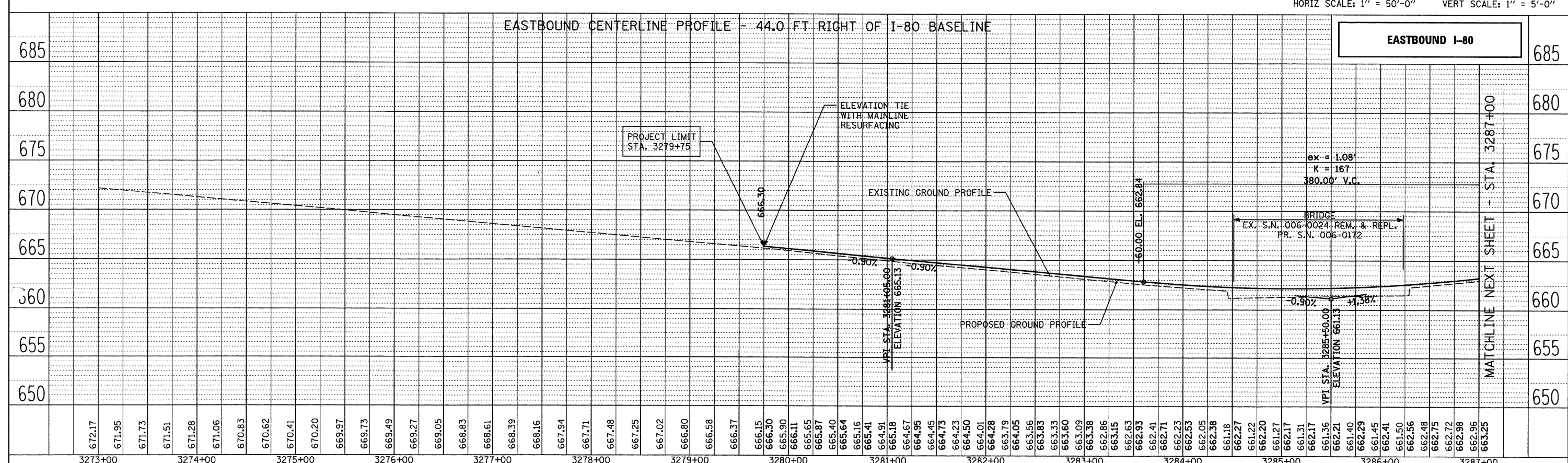

645	672.17	671.95	671.73	671.51	671.28	671.06	670.83	670.62	670.41	670.20	669.97	669.73	669.49	669.27	669.05	668.83	668.61	668.39	668.16	667.94	667.71	667.48	667.25	667.02	666.80	666.58	666.37	666.15	666.30	665.90	666.11	665.65	665.87	665.40	665.64	665.16	665.41	664.91	665.18	664.67	664.95	664.45	664.73	664.23	664.50	664.01	664.28	663.79	664.05	663.56	663.83	663.33	663.60	663.09	663.38	662.86	663.15	662.63	662.93	662.41	662.71	662.23	662.53	662.05	662.38	661.18	662.27	661.22	662.20	661.27	662.17	661.31	662.17	661.36	662.21	661.40	662.29	661.45	662.41	661.50	662.56	662.48	662.75	662.72	662.98	662.96	663.25
	3273+00		3274+00		3275+00		3276+00		3277+00		3278+00		3279+00		3280+00		3281+00		3282+00		3283+00		3284+00		3285+00		3286+00		3287+00																																																										

DATE: 8/14/2009  
 TIME: 11:00 AM  
 DRAWN: JDF  
 CHECKED: JDF  
 DESIGNED: CAC  
 USER: #USER#

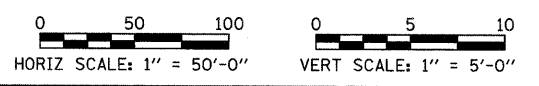
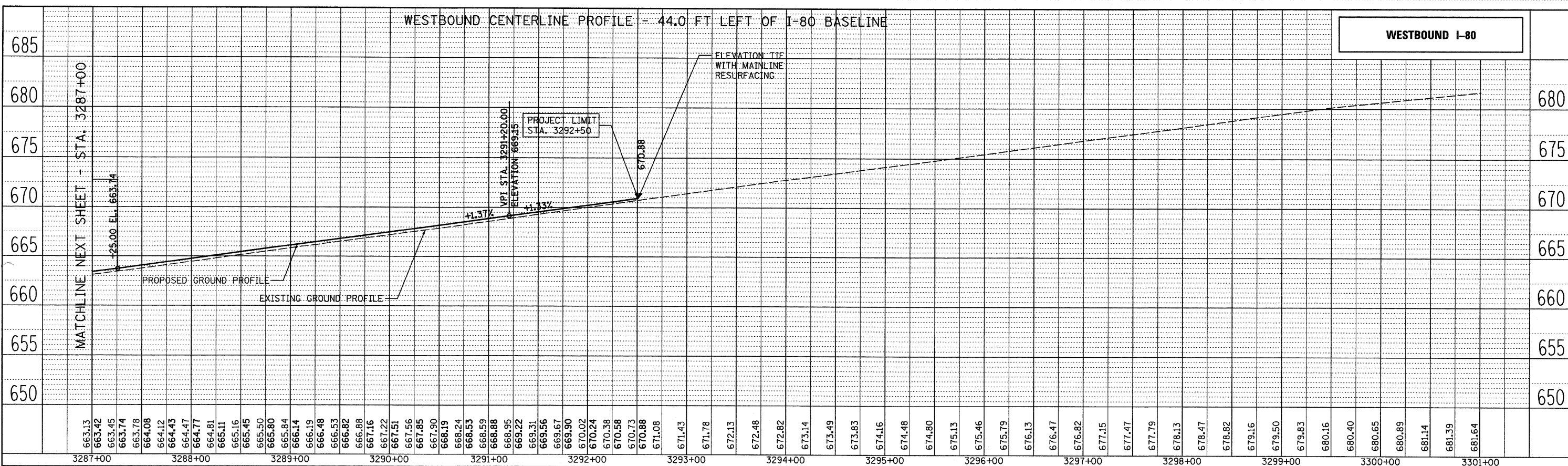

<b>TYLIN INTERNATIONAL</b> USER NAME = #USER# PLOT SCALE = #SCALE# PLOT DATE = 8/14/2009	DESIGNED - CAC	REVISED -	<b>STATE OF ILLINOIS</b> <b>DEPARTMENT OF TRANSPORTATION</b> <b>F.A.I. ROUTE 80 (I-80)</b> <b>EXISTING AND PROPOSED PROFILES</b> SCALE: AS SHOWN SHEET NO. 2 OF 2 SHEETS STA. 3287+00 TO STA. 3301+00	F.A. RTE. 80	SECTION	COUNTY	TOTAL SHEETS	SHEET NO.
	DRAWN - CAC	REVISED -		BUREAU	CONTRACT NO. 66908	3	48	
	CHECKED - JDF	REVISED -		ILLINOIS FED. AID PROJECT				
	DATE - 08/14/2009	REVISED -		06-17BR & BR-1,7VB-M, 6BR & 6, 7 RS-1 & 1J				



- NOTES:**
1. MAINLINE RESURFACING, 1 3/4"
    - INCLUDES:
    - 1 3/4" POLYMERIZED HOT-MIX ASPHALT SURFACE COURSE, MIX "D", N105
  2. POLYMERIZED LEVELING BINDER (MACHINE METHOD), N90 (3/4" MIN. VARIABLE DEPTH) (AS NECESSARY)
  3. SHOULDER RESURFACING, 1 3/4"
    - INCLUDES:
    - 1 3/4" HOT-MIX ASPHALT SURFACE COURSE, MIX "C", N50
  - 3A. SHOULDER RESURFACING, 1 3/4"
    - INCLUDES:
    - 1 3/4" POLYMERIZED HOT-MIX ASPHALT SURFACE COURSE, MIX "D", N105

4. FULL-DEPTH HOT-MIX ASPHALT SHOULDERS, 12"
  - INCLUDES:
  - 1 3/4" HOT-MIX ASPHALT SURFACE COURSE, MIX "C", N50
  - 10 1/4" HOT-MIX ASPHALT BINDER COURSE, IL-19.0, N50
  - 6" AGGREGATE BASE COURSE, TYPE A
- 4A. FULL-DEPTH HOT-MIX ASPHALT SHOULDERS, 12"
  - INCLUDES:
  - 1 3/4" POLYMERIZED HOT-MIX ASPHALT SURFACE COURSE, MIX "D", N105
  - 10 1/4" HOT-MIX ASPHALT BINDER COURSE, IL-19.0, N90
  - 6" AGGREGATE BASE COURSE, TYPE A
5. FULL-DEPTH CRC PAVEMENT
  - INCLUDES:
  - 10" CONTINUOUSLY REINFORCED PORTLAND CEMENT CONCRETE PAVEMENT
  - 4" STABILIZED SUB-BASE (HMA)
  - 12" AGGREGATE SUBGRADE

6. FULL-DEPTH CONCRETE SHOULDERS
  - INCLUDES:
  - 10" PORTLAND CEMENT CONCRETE SHOULDERS
  - 4" SUB-BASE GRANULAR MATERIAL, TYPE C
  - 12" AGGREGATE SUBGRADE
7. SEE ROADWAY DETAILS SHEET FOR TABLE OF STATIONS/OFFSETS

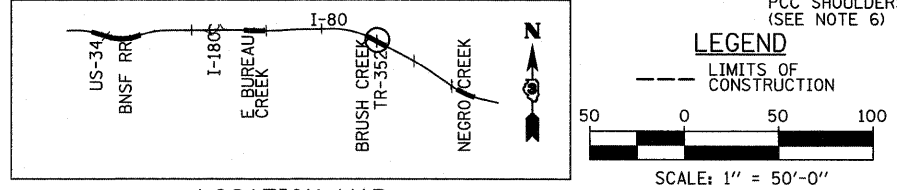
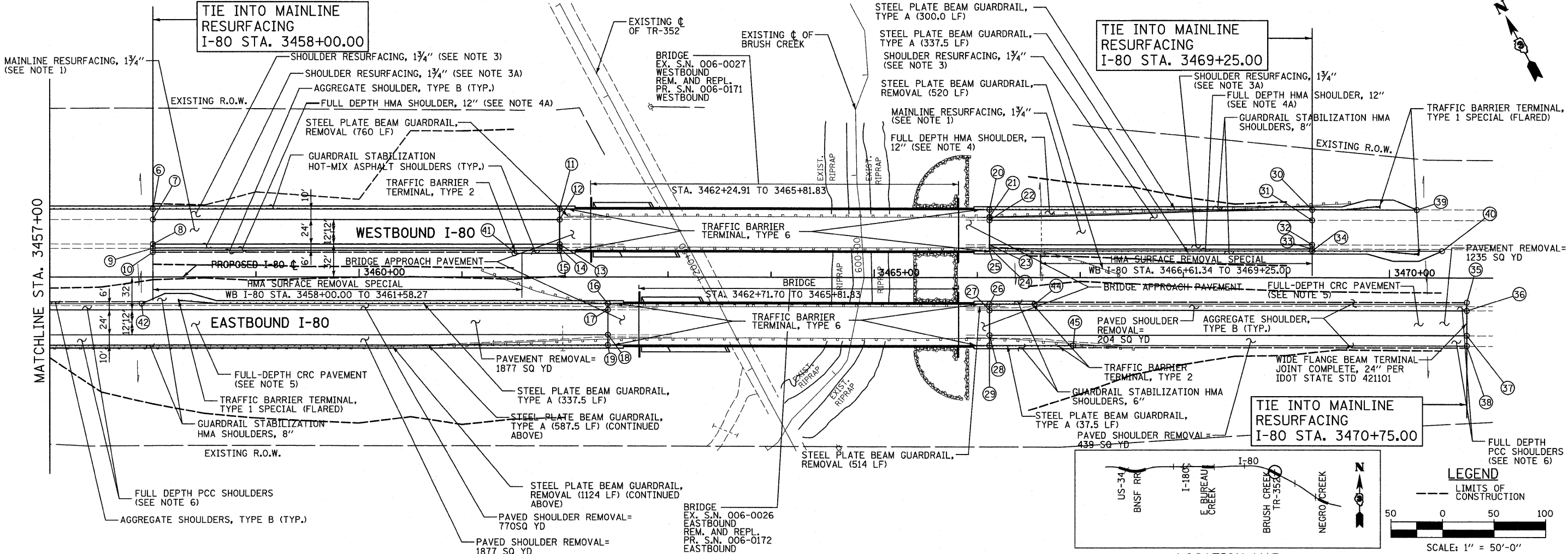
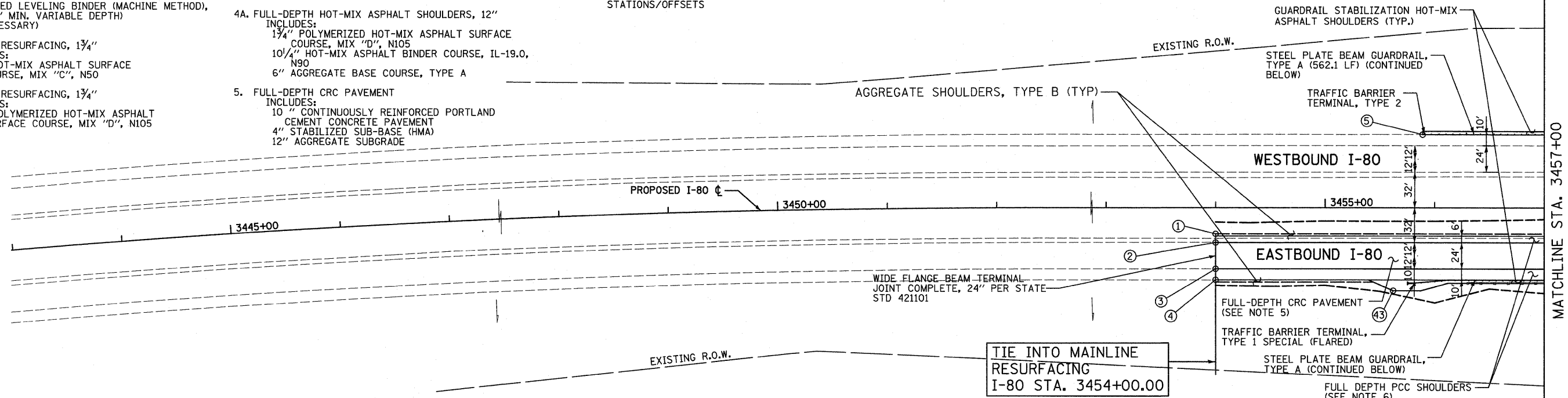

**LEGEND**

--- LIMITS OF CONSTRUCTION

50 0 50 100

SCALE: 1" = 50'-0"

**TYLIN INTERNATIONAL**

USER NAME = #USER#	DESIGNED - CAC	REVISED -
PLOT SCALE = #SCALE#	DRAWN - CAC	REVISED -
PLOT DATE = 8/14/2009	CHECKED - JDF	REVISED -
	DATE - 08/14/2009	REVISED -

**STATE OF ILLINOIS  
DEPARTMENT OF TRANSPORTATION**

**F.A.I. ROUTE 80 (I-80)**

SCALE:	SHEET NO.	OF SHEETS	STA.	TO STA.
--------	-----------	-----------	------	---------

F.A.I. RTE.	SECTION	COUNTY	TOTAL SHEETS	SHEET NO.
80		BUREAU	377	49
FED. ROAD DIST. NO.			ILLINOIS FED. AID PROJECT	
			CONTRACT NO. 66908	

\* 06-17BR & BR-1,7VB-M, 6BR & 6, 7 RS-1 & IJ

P:\602429\1-80\road\602429\_30\_C\Z01993PLNDET01.dgn  
 8/14/2009 4:32:25 PM

PLAN VIEW STATION/OFFSET CALLOUTS

POINT NUMBER	POINT DESCRIPTION	STATION	OFFSET
1	BACK OF SHOULDER - CONTRACT LIMIT	3454+00.00	24.00 RT
2	EOP - CONTRACT LIMIT	3454+00.00	32.00 RT
3	EOP - CONTRACT LIMIT	3454+00.00	56.00 RT
4	BACK OF SHOULDER - CONTRACT LIMIT	3454+00.00	66.00 RT
5	GUARDRAIL STABILIZATION - CONTRACT LIMIT	3455+50.00	66.22 LT
6	BACK OF SHOULDER - CONTRACT LIMIT	3455+50.00	66.00 LT
7	EOP - CONTRACT LIMIT	3455+50.00	56.00 LT
8	EOP - CONTRACT LIMIT	3455+50.00	32.00 LT
9	BACK OF SHOULDER - CONTRACT LIMIT	3461+65.56	28.21 LT
10	BACK OF SHOULDER - CONTRACT LIMIT	3461+65.56	24.00 LT
11	BACK OF SHOULDER - BRIDGE LIMIT	3461+65.56	66.00 LT
12	EOP - BRIDGE LIMIT	3461+65.56	56.00 LT
13	EOP - BRIDGE LIMIT	3467+99.24	32.00 LT
14	BACK OF SHOULDER - BRIDGE LIMIT	3468+27.66	28.42 LT
15	BACK OF SHOULDER - BRIDGE LIMIT	3468+77.00	26.00 LT
16	BACK OF SHOULDER - BRIDGE LIMIT	3468+97.22	26.00 RT
17	EOP - BRIDGE LIMIT	3469+11.74	32.00 RT
18	EOP - BRIDGE LIMIT	3469+13.44	56.00 RT
19	BACK OF SHOULDER - BRIDGE LIMIT	3469+17.33	66.00 RT
20	BACK OF SHOULDER - BRIDGE LIMIT	3469+26.66	66.00 LT
21	BACK OF SHOULDER - BRIDGE LIMIT	3469+27.62	58.00 LT
22	EOP - BRIDGE LIMIT	3469+29.00	56.00 LT
23	EOP - BRIDGE LIMIT	3469+47.52	32.00 LT
24	BACK OF SHOULDER - BRIDGE LIMIT	3469+49.22	28.80 LT
25	BACK OF SHOULDER - BRIDGE LIMIT	3469+51.56	26.00 LT
26	BACK OF SHOULDER - BRIDGE LIMIT	3469+60.89	26.00 RT
27	EOP - BRIDGE LIMIT	3469+63.40	32.00 RT
28	EOP - BRIDGE LIMIT	3469+64.78	56.00 RT
29	BACK OF SHOULDER - BRIDGE LIMIT	3471+08.15	66.00 RT
30	BACK OF SHOULDER - CONTRACT LIMIT	3471+09.53	66.00 LT
31	EOP - CONTRACT LIMIT	3471+12.04	56.00 LT
32	EOP - CONTRACT LIMIT	3471+21.37	32.00 LT
33	BACK OF SHOULDER - CONTRACT LIMIT	3471+23.71	28.00 LT
34	BACK OF SHOULDER - CONTRACT LIMIT	3471+25.41	26.00 LT
35	BACK OF SHOULDER - CONTRACT LIMIT	3471+43.94	24.00 RT
36	EOP - CONTRACT LIMIT	3471+45.31	32.00 RT
37	EOP - CONTRACT LIMIT	3471+46.27	56.00 RT
38	BACK OF SHOULDER - CONTRACT LIMIT	3471+55.60	66.00 RT
39	LIMIT OF GUARDRAIL STABILIZATION	3471+59.49	66.00 LT
40	LIMIT OF GUARDRAIL STABILIZATION	3471+61.19	26.00 LT
41	LIMIT OF GUARDRAIL STABILIZATION	3471+75.71	23.00 LT
42	LIMIT OF GUARDRAIL STABILIZATION	3471+95.94	26.00 RT
43	LIMIT OF GUARDRAIL STABILIZATION	3472+45.28	76.00 RT
44	LIMIT OF GUARDRAIL STABILIZATION	3471+73.69	26.00 RT
45	LIMIT OF GUARDRAIL STABILIZATION	3475+33.45	66.00 RT

<b>TYLIN INTERNATIONAL</b> USER NAME = #USER# PLOT SCALE = #SCALE# PLOT DATE = 8/14/2009	DESIGNED - CAC	REVISED -	<b>STATE OF ILLINOIS DEPARTMENT OF TRANSPORTATION</b>	<b>F.A.I. ROUTE 80 (I-80) ROADWAY DETAILS SHEET</b>			F.A.I. RTE. 80	SECTION •	COUNTY	TOTAL SHEETS 344	SHEET NO. 50
	DRAWN - CAC	REVISED -		SCALE:	SHEET NO. OF SHEETS	STA. TO STA.	FED. ROAD DIST. NO.	ILLINOIS FED. AID PROJECT	CONTRACT NO. 66908		
	CHECKED - JDF	REVISED -		• 06-L7BR & BR-1.7VB-M, 6BR & 6, 7 RS-1 & 11							
DATE - 08/14/2009	REVISED -										

REVIEWED  
 ALIGNED CHECKED  
 PLOTTED  
 NO. OF PAGES  
 FILE NAME

REVIEWED  
 GRADES CHECKED  
 ELEVATIONS NOTED  
 NO. OF PAGES  
 FILE NAME

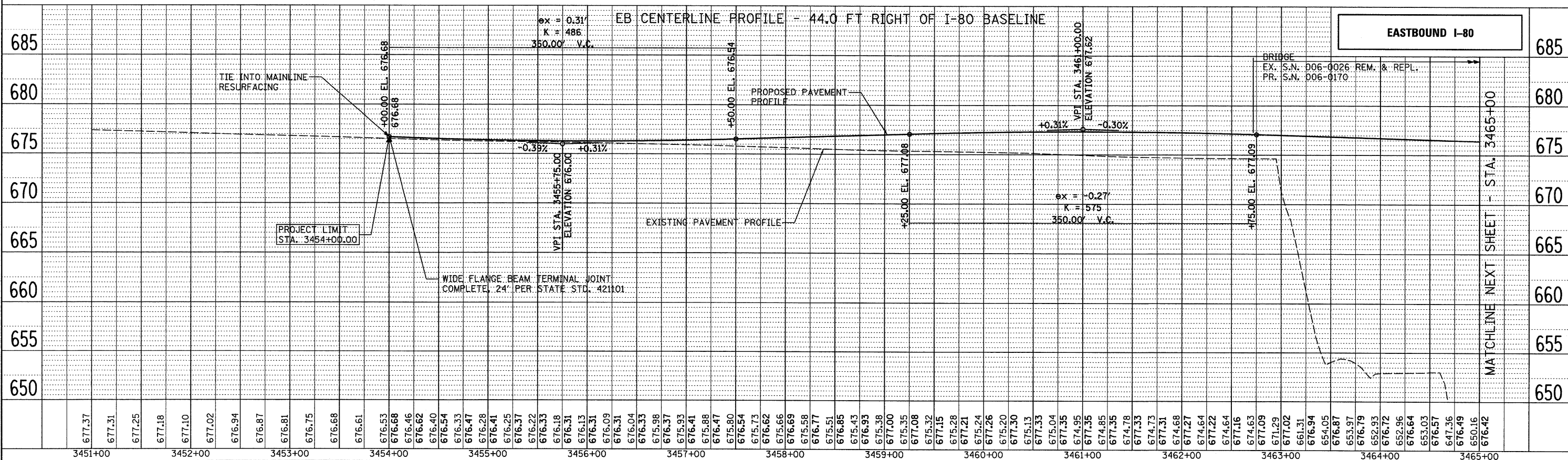
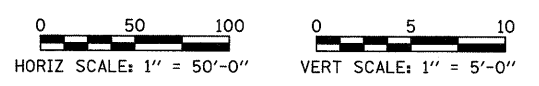
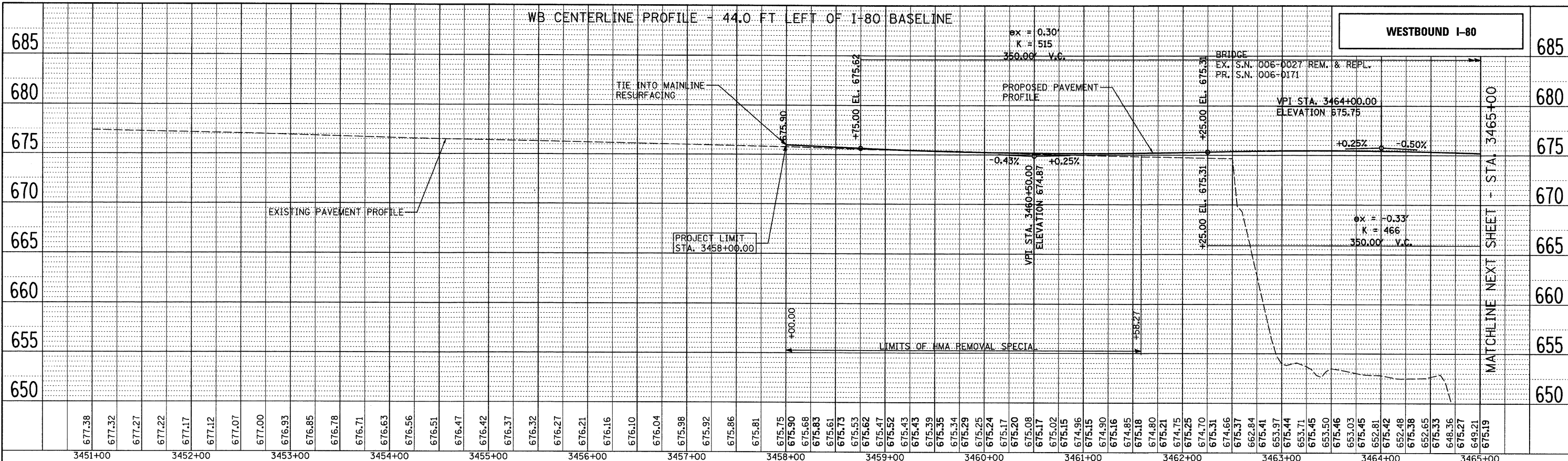

<b>TYLIN INTERNATIONAL</b> USER NAME = #USER* PLOT SCALE = #SCALE* PLOT DATE = 8/14/2009	DESIGNED - CAC	REVISED -	<b>STATE OF ILLINOIS</b> <b>DEPARTMENT OF TRANSPORTATION</b> <b>F.A.I. ROUTE 80 (I-80)</b> <b>EXISTING AND PROPOSED PROFILES</b> SCALE: AS SHOWN SHEET NO. 1 OF 2 SHEETS STA. 3451+00 TO STA. 3465+00	F.A. RTE. 80	SECTION	COUNTY	TOTAL SHEETS	SHEET NO.
	DRAWN - CAC	REVISED -		BUREAU	344	51		
	CHECKED - JDF	REVISED -		CONTRACT NO. 66908				
	DATE - 08/14/2009	REVISED -		ILLINOIS FED. AID PROJECT				

PLANNING  
SURVEYED  
ALIGNED  
NOTED  
CHECKED  
REL. OF WAY CHECKED  
NO. \_\_\_\_\_  
DATE FILE NAME

PROFILE  
PLOTTED  
CHECKED  
NO. \_\_\_\_\_  
DATE

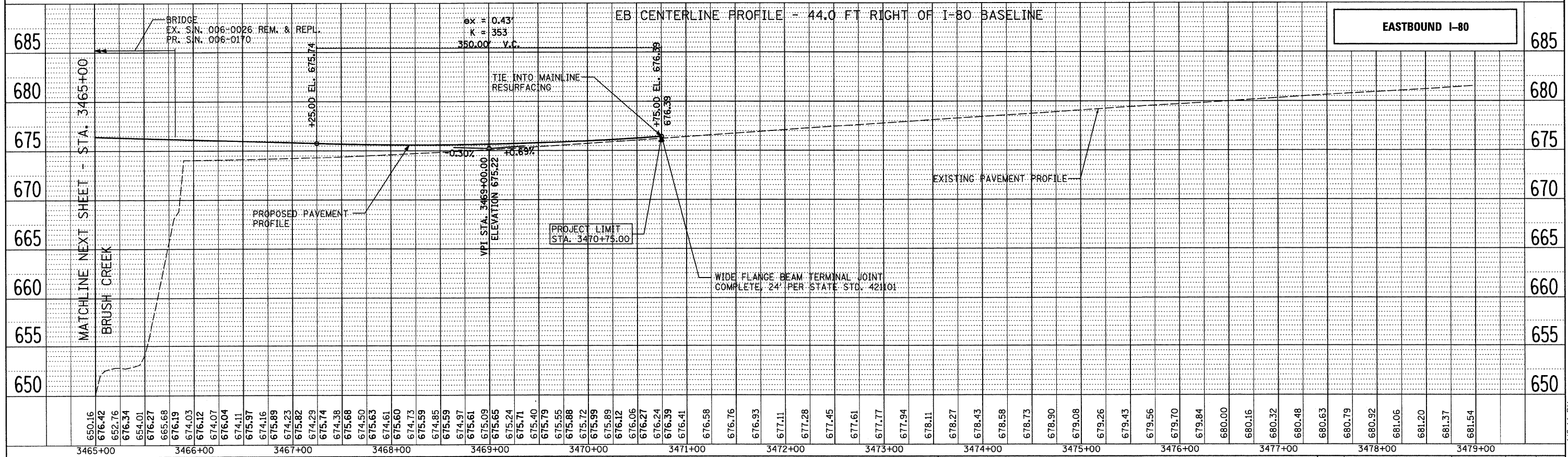
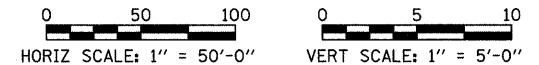
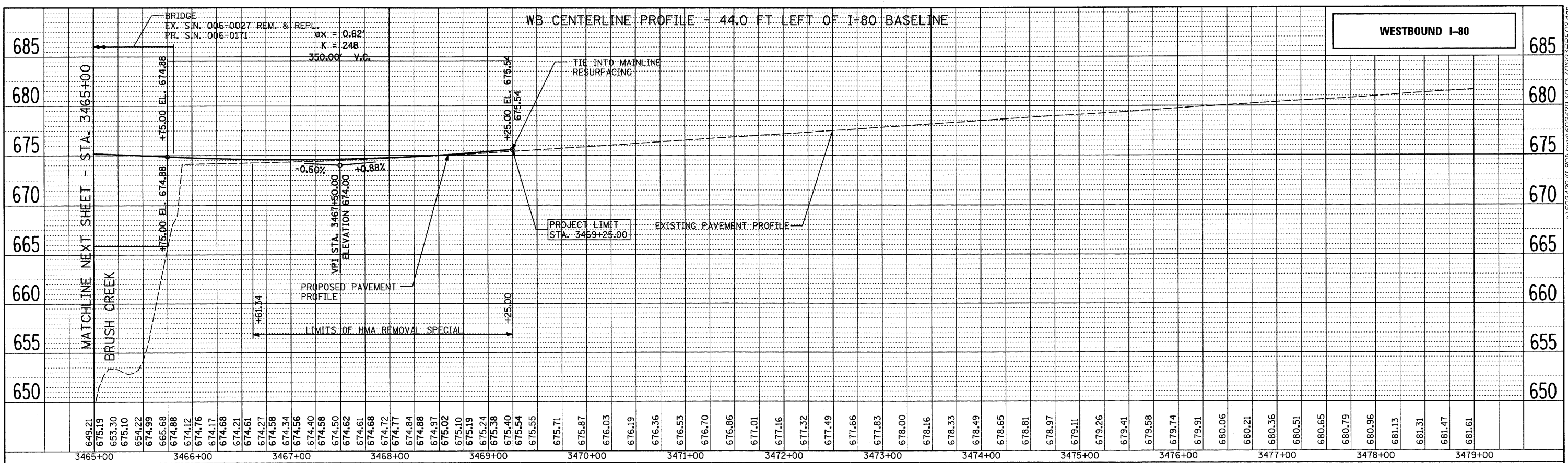

<b>TYLIN INTERNATIONAL</b> USER NAME = *USER* PLOT SCALE = *SCALE* PLOT DATE = 8/14/2009	DESIGNED - CAC DRAWN - CAC CHECKED - JDF DATE - 08/14/2009	REVISED - REVISED - REVISED - REVISED -	<b>STATE OF ILLINOIS</b> <b>DEPARTMENT OF TRANSPORTATION</b>	<b>F.A.I. ROUTE 80 (I-80)</b> <b>EXISTING AND PROPOSED PROFILES</b>	F.A. RTE. 80 SECTION * COUNTY * BUREAU 344 CONTRACT NO. 66908	TOTAL SHEETS 92 SHEET NO. 92
	SCALE: AS SHOWN    SHEET NO. 2 OF 2 SHEETS    STA. 3465+00 TO STA. 3479+00			FED. ROAD DIST. NO. ILLINOIS FED. AID PROJECT * 06-17BR & BR-1,7VB-M, 6BR & 6, 7 RS-1 & 11		

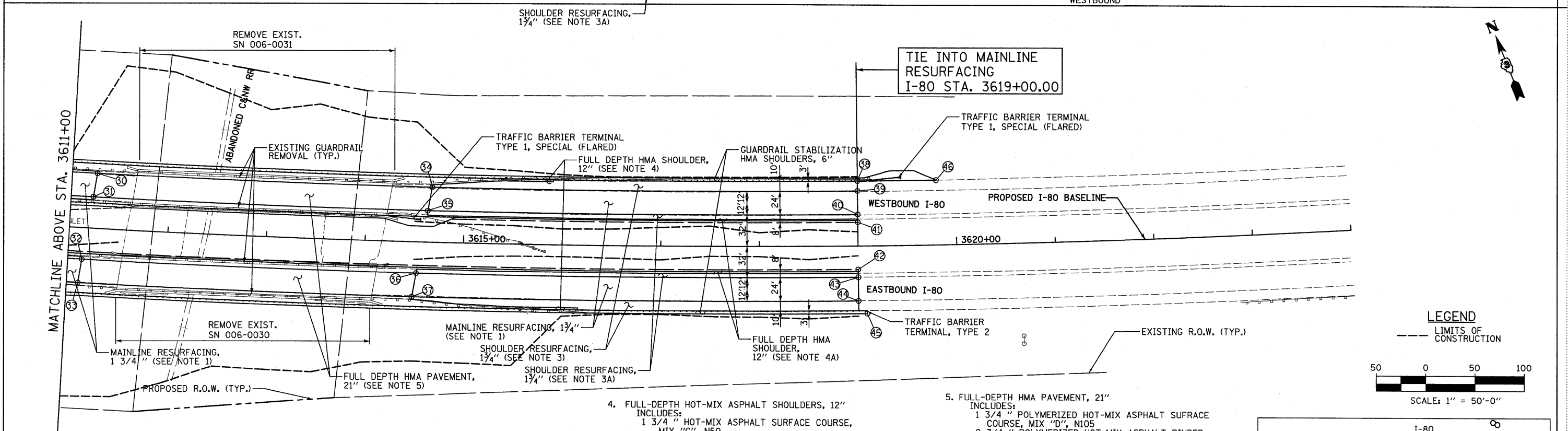
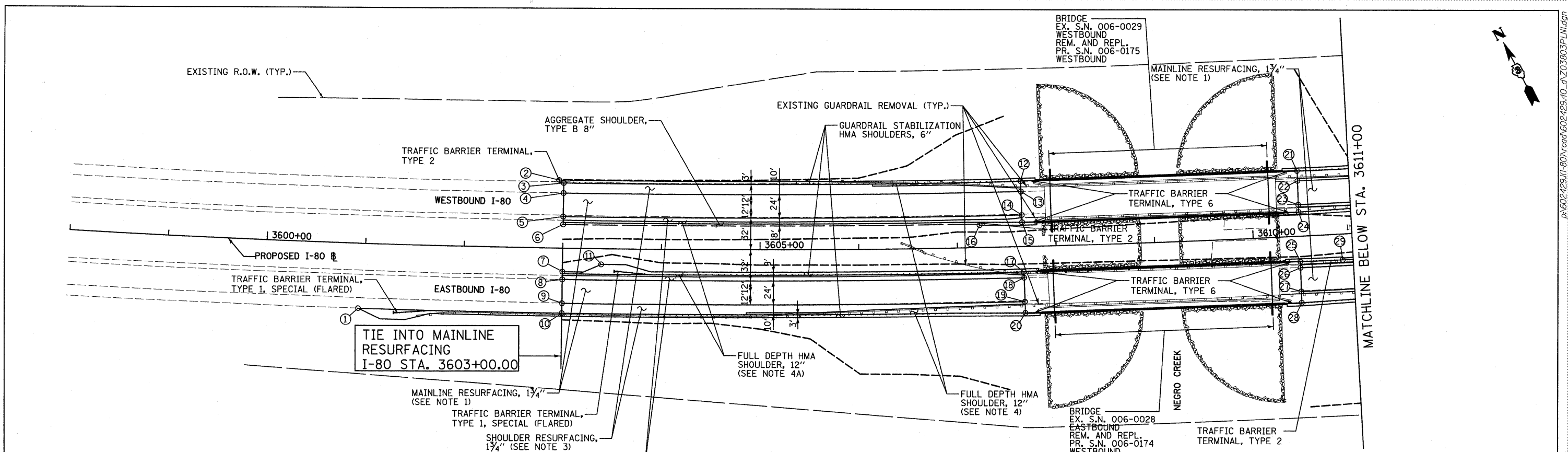

- NOTES:**
1. MAINLINE RESURFACING, 1 3/4 " INCLUDES: 1 3/4 " POLYMERIZED HOT-MIX ASPHALT SURFACE COURSE, MIX "D", N105
  2. POLYMERIZED LEVELING BINDER (MACHINE METHOD), N90 ( 3/4 " MIN. VARIABLE DEPTH) (AS NECESSARY)

3. SHOULDER RESURFACING, 1 3/4 " INCLUDES: 1 3/4 " HOT-MIX ASPHALT SURFACE COURSE, MIX "C", N50
- 3A. SHOULDER RESURFACING, 1 3/4 " INCLUDES: 1 3/4 " POLYMERIZED HOT-MIX ASPHALT SURFACE COURSE, MIX "D", N105

4. FULL-DEPTH HOT-MIX ASPHALT SHOULDERS, 12" INCLUDES: 1 3/4 " HOT-MIX ASPHALT SURFACE COURSE, MIX "C", N50 10 1/4 " HOT-MIX ASPHALT BINDER COURSE, IL-19.0, N50 6" AGGREGATE BASE COURSE, TYPE A
- 4A. FULL-DEPTH HOT-MIX ASPHALT SHOULDERS, 12" INCLUDES: 1 3/4 " POLYMERIZED HOT-MIX ASPHALT SURFACE COURSE, MIX "D", N105 10 1/4 " HOT-MIX ASPHALT BINDER COURSE, IL-19.0, N90 6" AGGREGATE BASE COURSE, TYPE A

5. FULL-DEPTH HMA PAVEMENT, 21" INCLUDES: 1 3/4 " POLYMERIZED HOT-MIX ASPHALT SURFACE COURSE, MIX "D", N105 2 3/4 " POLYMERIZED HOT-MIX ASPHALT BINDER COURSE, N105 12 3/4 " HOT-MIX ASPHALT BINDER COURSE, IL-19.0, N90 4" HOT-MIX ASPHALT BINDER COURSE, N70 12" AGGREGATE BASE
6. SEE ROADWAY DETAILS SHEET FOR TABLE OF STATIONS/OFFSETS.

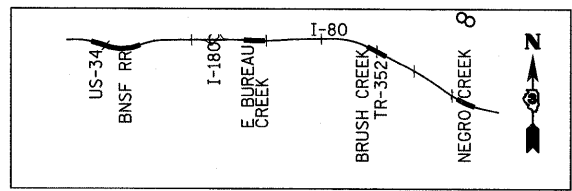
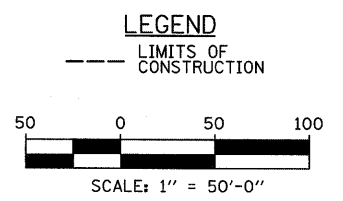

<b>TYLIN INTERNATIONAL</b> USER NAME = #USER# PLOT SCALE = #SCALE# PLOT DATE = 8/14/2009	DESIGNED - CAC	REVISED -	<b>STATE OF ILLINOIS</b> <b>DEPARTMENT OF TRANSPORTATION</b>	<b>F.A.I. ROUTE 80 (I-80)</b> <b>PLAN SHEET</b>			F.A.I. RTE. 80	SECTION	COUNTY	TOTAL SHEETS	SHEET NO.
	DRAWN - CAC	REVISED -		SCALE:	SHEET NO.	OF SHEETS	STA.	TO STA.	BUREAU	349	77
	CHECKED - JDF	REVISED -					FED. ROAD DIST. NO.		ILLINOIS FED. AID PROJECT		CONTRACT NO. 66908
DATE - 08/14/2009	REVISED -								• 06-L7BR & BR-1,7VB-M, 6BR & 6, 7 RS-1 & IJ		

P:\602429\1-80\road\602429.40.d\Z03803PLNDET01.dgn  
 8/14/2009 5:40:56 PM

PLAN VIEW STATION/OFFSET CALLOUTS

POINT NUMBER	POINT DESCRIPTION	STATION	OFFSET
1	GUARDRAIL STABILIZATION	3600+94.31	66.00 RT
2	GUARDRAIL STABILIZATION - CONTRACT LIMIT	3602+95.27	69.00 LT
3	BACK OF SHOULDER - CONTRACT LIMIT	3603+00.00	66.00 LT
4	EOP - CONTRACT LIMIT	3603+00.00	56.00 LT
5	EOP - CONTRACT LIMIT	3603+00.00	32.00 LT
6	BACK OF SHOULDER - CONTRACT LIMIT	3603+00.00	24.00 LT
7	BACK OF SHOULDER - CONTRACT LIMIT	3603+00.00	24.00 RT
8	EOP - CONTRACT LIMIT	3603+00.00	32.00 RT
9	EOP - CONTRACT LIMIT	3603+00.00	56.00 RT
10	BACK OF SHOULDER - CONTRACT LIMIT	3603+00.00	66.00 RT
11	GUARDRAIL STABILIZATION	3603+39.05	16.00 RT
12	BACK OF SHOULDER - BRIDGE LIMIT	3607+65.57	66.31 LT
13	EOP - BRIDGE LIMIT	3607+65.70	56.00 LT
14	EOP - BRIDGE LIMIT	3607+66.00	32.00 LT
15	BACK OF SHOULDER - BRIDGE LIMIT	3607+66.09	24.64 LT
16	GUARDRAIL STABILIZATION	3607+22.93	22.55 LT
17	BACK OF SHOULDER - BRIDGE LIMIT	3607+66.70	26.00 RT
18	EOP - BRIDGE LIMIT	3607+66.78	32.00 RT
19	EOP - BRIDGE LIMIT	3607+67.07	56.00 RT
20	BACK OF SHOULDER - BRIDGE LIMIT	3607+67.20	67.43 RT
21	BACK OF SHOULDER - BRIDGE LIMIT	3610+47.71	66.31 LT
22	EOP - BRIDGE LIMIT	3610+47.58	56.00 LT
23	EOP - BRIDGE LIMIT	3610+47.28	32.00 LT
24	BACK OF SHOULDER - BRIDGE LIMIT	3610+47.19	24.64 LT
25	BACK OF SHOULDER - BRIDGE LIMIT	3610+46.58	25.77 RT
26	EOP - BRIDGE LIMIT	3610+46.50	32.00 RT
27	EOP - BRIDGE LIMIT	3610+46.21	56.00 RT
28	BACK OF SHOULDER - BRIDGE LIMIT	3610+46.08	67.43 RT
29	GUARDRAIL STABILIZATION	3610+89.50	26.00 RT
30	EOP	3611+25.57	56.00 LT
31	EOP	3611+22.59	32.00 LT
32	EOP	3611+14.34	32.00 RT
33	EOP	3611+11.65	56.00 RT
34	EOP	3614+66.74	56.00 LT
35	EOP	3614+62.77	32.00 LT
36	EOP	3614+52.49	32.00 RT
37	EOP	3614+48.68	56.00 RT
38	BACK OF SHOULDER - CONTRACT LIMIT	3619+00.00	66.00 LT
39	EOP - CONTRACT LIMIT	3619+00.00	56.00 LT
40	EOP - CONTRACT LIMIT	3619+00.00	32.00 LT
41	BACK OF SHOULDER - CONTRACT LIMIT	3619+00.00	24.00 LT
42	BACK OF SHOULDER - CONTRACT LIMIT	3619+00.00	24.00 RT
43	EOP - CONTRACT LIMIT	3619+00.00	32.00 RT
44	EOP - CONTRACT LIMIT	3619+00.00	56.00 RT
45	GUARDRAIL STABILIZATION - CONTRACT LIMIT	3619+08.66	69.00 RT
46	GUARDRAIL STABILIZATION	3619+80.23	65.72 LT

<b>TYLIN INTERNATIONAL</b>	USER NAME = #USER#	DESIGNED - CAC	REVISED -	<b>STATE OF ILLINOIS DEPARTMENT OF TRANSPORTATION</b>	<b>F.A.I. ROUTE 80 (I-80) ROADWAY DETAILS SHEET</b>	F.A.I. RTE. 80	SECTION •	COUNTY	TOTAL SHEETS 74	SHEET NO. 79
	PLOT SCALE = #SCALE#	CHECKED - JDF	REVISED -			BUREAU	CONTRACT NO. 66908			
	PLOT DATE = 8/14/2009	DATE - 08/14/2009	REVISED -			SCALE:	SHEET NO. OF SHEETS	STA. TO STA.	FED. ROAD DIST. NO.	ILLINOIS FED. AID PROJECT

SURVEYED  
 PLOTTED  
 CHECKED  
 NOTE BOOK  
 NO. \_\_\_\_\_  
 CAD FILE NAME  
 NO. \_\_\_\_\_

SURVEYED  
 PLOTTED  
 CHECKED  
 NOTE BOOK  
 NO. \_\_\_\_\_  
 STRUCTURE NOTATION CRKD  
 NO. \_\_\_\_\_

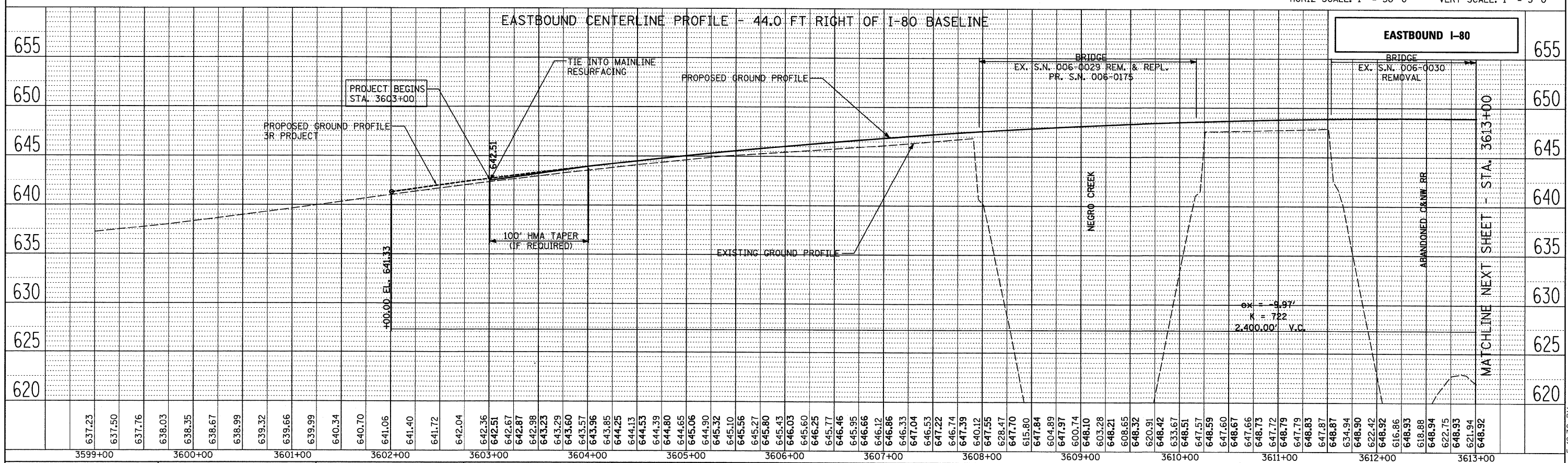
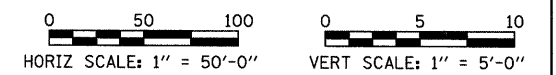
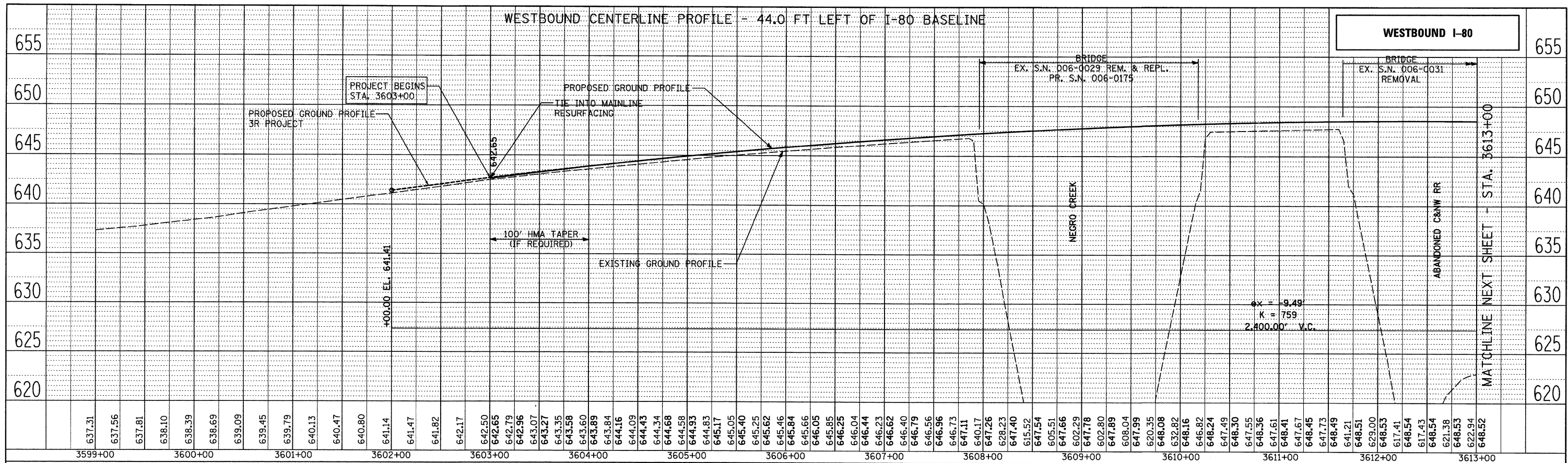

USER NAME = #USER#	DESIGNED - CAC	REVISED -
PLOT SCALE = #SCALE#	DRAWN - CAC	REVISED -
PLOT DATE = 8/14/2009	CHECKED - JDF	REVISED -
	DATE - 08/14/2009	REVISED -

**STATE OF ILLINOIS**  
**DEPARTMENT OF TRANSPORTATION**

<b>F.A.I. ROUTE 80 (I-80)</b>		
<b>EXISTING AND PROPOSED PROFILES</b>		
SCALE: AS SHOWN	SHEET NO. 1 OF 2 SHEETS	STA. 3599+00 TO STA. 3613+00

F.A. RTE. 80	SECTION	COUNTY	TOTAL SHEETS	SHEET NO.
		BUREAU	34	53
CONTRACT NO. 66908				

PLAN  
 SURVEYED  
 PLOTTED  
 CHECKED  
 REVISIONS  
 NO. DATE  
 CADD FILE NAME

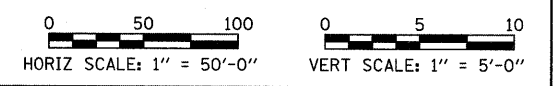
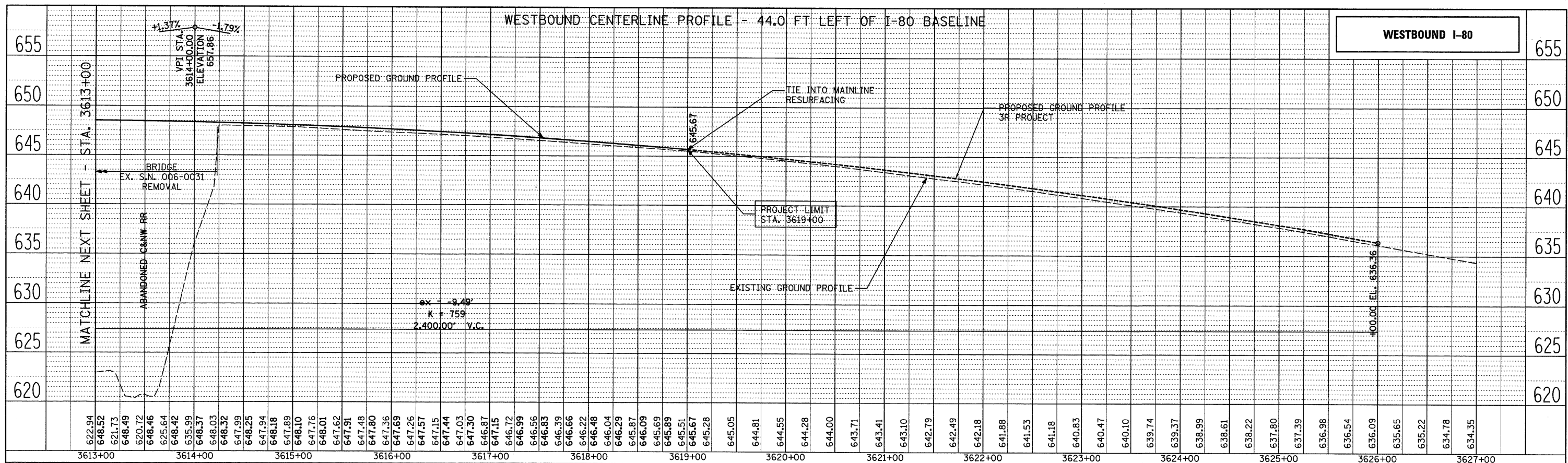

PROFILE  
 SURVEYED  
 PLOTTED  
 CHECKED  
 REVISIONS  
 NO. DATE  
 STRUCTURE NOTATIONS: OKRD

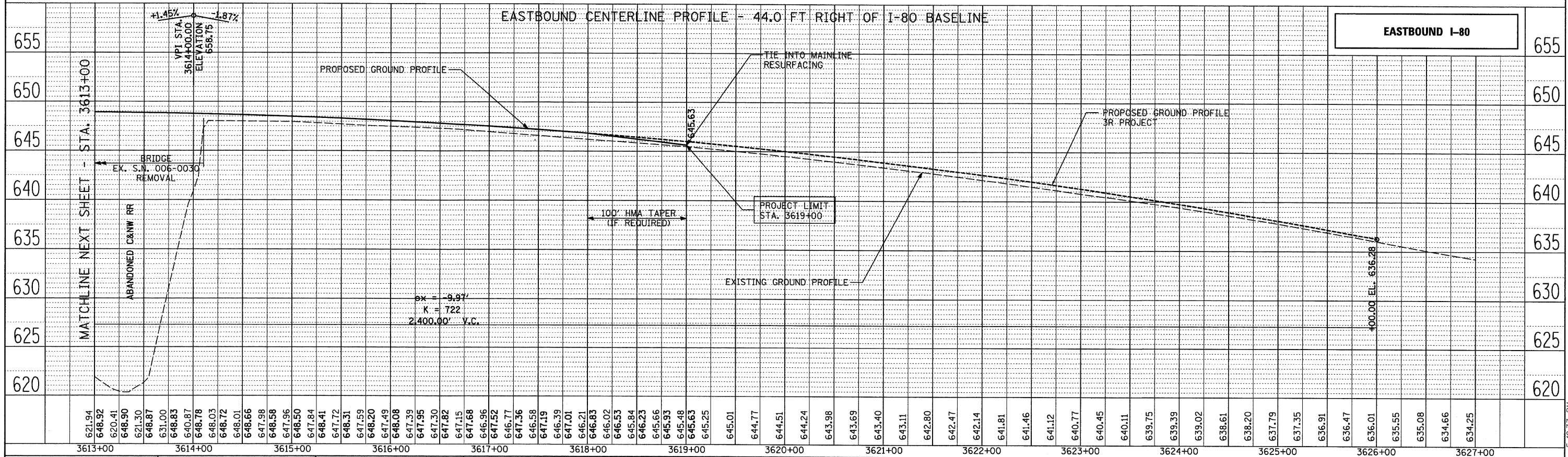

<b>TYLIN INTERNATIONAL</b> USER NAME = #USER# PLOT SCALE = #SCALE# PLOT DATE = 8/14/2009	DESIGNED - CAC	REVISED -	<b>STATE OF ILLINOIS</b> <b>DEPARTMENT OF TRANSPORTATION</b> <b>F.A.I. ROUTE 80 (I-80)</b> <b>EXISTING AND PROPOSED PROFILES</b>	F.A. RTE. 80	SECTION	COUNTY	TOTAL SHEETS NO.	SHEET NO.
	DRAWN - CAC	REVISED -		BUREAU	CONTRACT NO. 66908			
	CHECKED - JDF	REVISED -		FED. ROAD DIST. NO. ILLINOIS FED. AID PROJECT • 06-17BR & BR-1,7VB-M, 6BR & 6, 7 RS-1 & 1				
DATE - 08/14/2009	REVISED -		SCALE: AS SHOWN	SHEET NO. 2 OF 2 SHEETS	STA. 3613+00 TO STA. 3627+00			

602429.1(i-80)\road\602429.40.d\203803PRF2.dgn  
 8/14/2009 5:40:33 PM



# BETWEEN MEDIAN CROSSOVERS

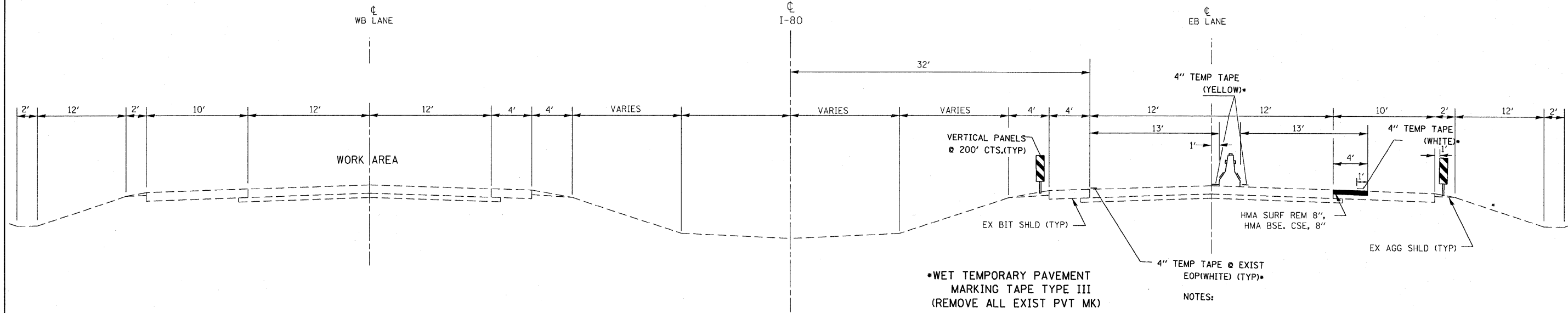

## STAGE I MAINLINE

STA 1408+00 TO STA 1429+00  
 STA 1444+00 TO STA 1604+00  
 STA 1620+00 TO STA 1749+00  
 STA 1768+00 TO STA 1802+25\*\*\*\*\*

SEE STAGE I CONSTRUCTIONS SHEETS FOR TRANSITIONS THROUGH CROSSOVERS \*\*\*\*\*

- NOTES:
1. THE CONTRACTOR HAS THE OPTION OF USING EITHER THE LINE ON THE TEMPORARY CONCRETE BARRIER OR ON THE PAVEMENT.
  2. THE COLOR OF THE REFLECTORS AND PAVEMENT/BARRIER MARKING LINE WILL VARY WITH STAGING AND SHALL MATCH THE EXISTING LINE IN THE WORK AREA.
  3. THE COST OF THE REFLECTORS IS INCLUDED IN THE COST OF TEMPORARY CONCRETE BARRIER

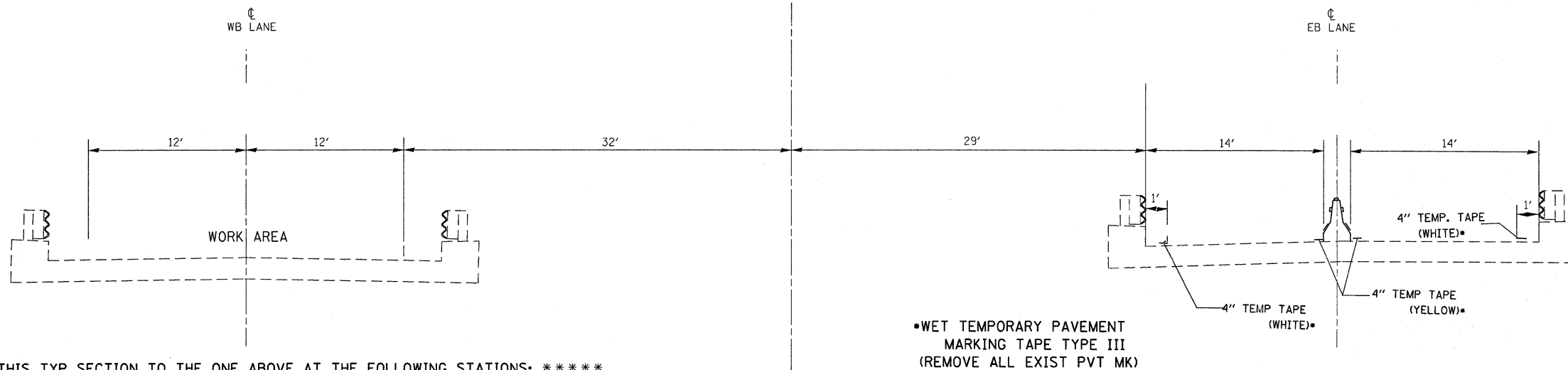

## STAGE I THROUGH BRIDGES

STA 1431+00 TO STA 1442+00  
 STA 1606+00 TO STA 1618+00  
 STA 1751+00 TO STA 1766+00\*\*\*\*\*

TRANSITION FROM THIS TYP SECTION TO THE ONE ABOVE AT THE FOLLOWING STATIONS: \*\*\*\*\*

STA 1429+00 TO STA 1431+00  
 STA 1442+00 TO STA 1444+00  
 STA 1604+00 TO STA 1606+00  
 STA 1618+00 TO STA 1620+00  
 STA 1749+00 TO STA 1751+00  
 STA 1766+00 TO STA 1768+00

- NOTES:
1. THE CONTRACTOR HAS THE OPTION OF USING EITHER THE LINE ON THE TEMPORARY CONCRETE BARRIER OR ON THE PAVEMENT.
  2. THE COLOR OF THE REFLECTORS AND PAVEMENT/BARRIER MARKING LINE WILL VARY WITH STAGING AND SHALL MATCH THE EXISTING LINE IN THE WORK AREA.
  3. THE COST OF THE REFLECTORS IS INCLUDED IN THE COST OF TEMPORARY CONCRETE BARRIER

\*\*06-[7BR&BR-1,7VB-M,6BR&6,7 RS-1 & I]

FILE NAME =	USER NAME = braboypc	DESIGNED -	REVISED -	<b>STATE OF ILLINOIS DEPARTMENT OF TRANSPORTATION</b>	<b>STAGE I CONSTRUCTION TYPICAL SECTIONS</b>			F.A. RTE.	SECTION	COUNTY	TOTAL SHEETS	SHEET NO.
ct:\pwork\pwork\braboypc\d0112640\d368909-sh-t-details.DGN	DRAWN -	REVISED -	REVISED -					I-80	**	BUREAU	344	57
PLOT SCALE = 50.7353' / IN.	CHECKED -	REVISED -	REVISED -		SCALE: _____	SHEET NO. _____ OF _____ SHEETS	STA. _____ TO STA. _____	CONTRACT NO. 66908				
PLOT DATE = Sep 07, 2009 - 02:16:11 PM	DATE -	REVISED -	REVISED -		ILLINOIS FED. AID PROJECT							

SYMBOLS

- ▨ Vertical Panel (back to back)
- ↑ Arrow board
- ⊥ Sign
- ⇄ Direction indicator barricade with steady burn monodirectional light

- Drum with steady burn monodirectional light
- ⦿ Type II barricade, drum, or vertical barricade with steady burn monodirectional light
- ① Wet temporary pavement marking tape - TY III shall be placed throughout the taper and along-side the work area. The edge lines shall be white and the line near the barrier shall be yellow.

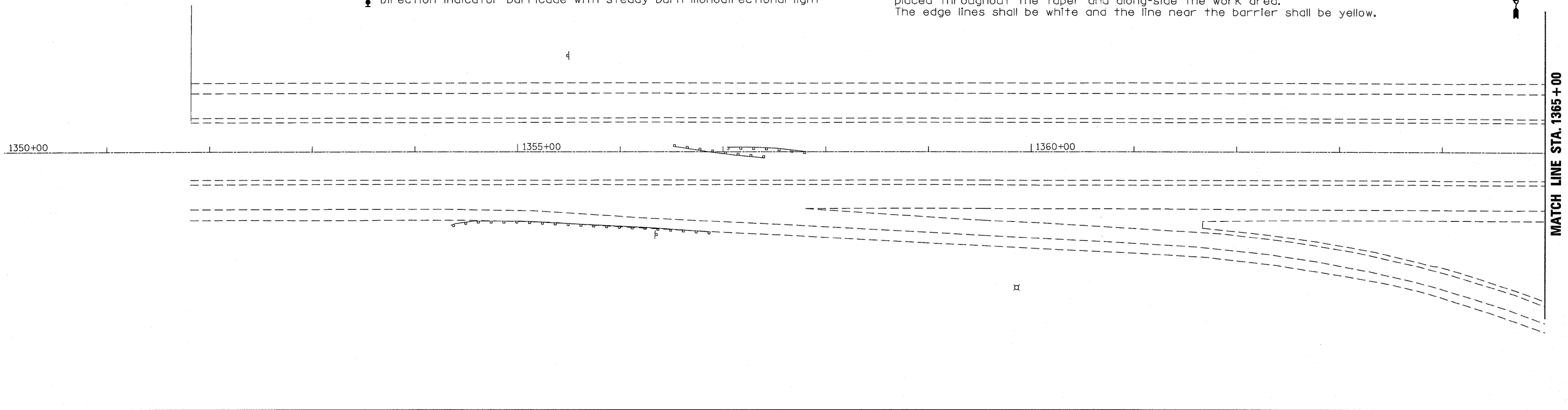

MATCH LINE STA. 1365+00

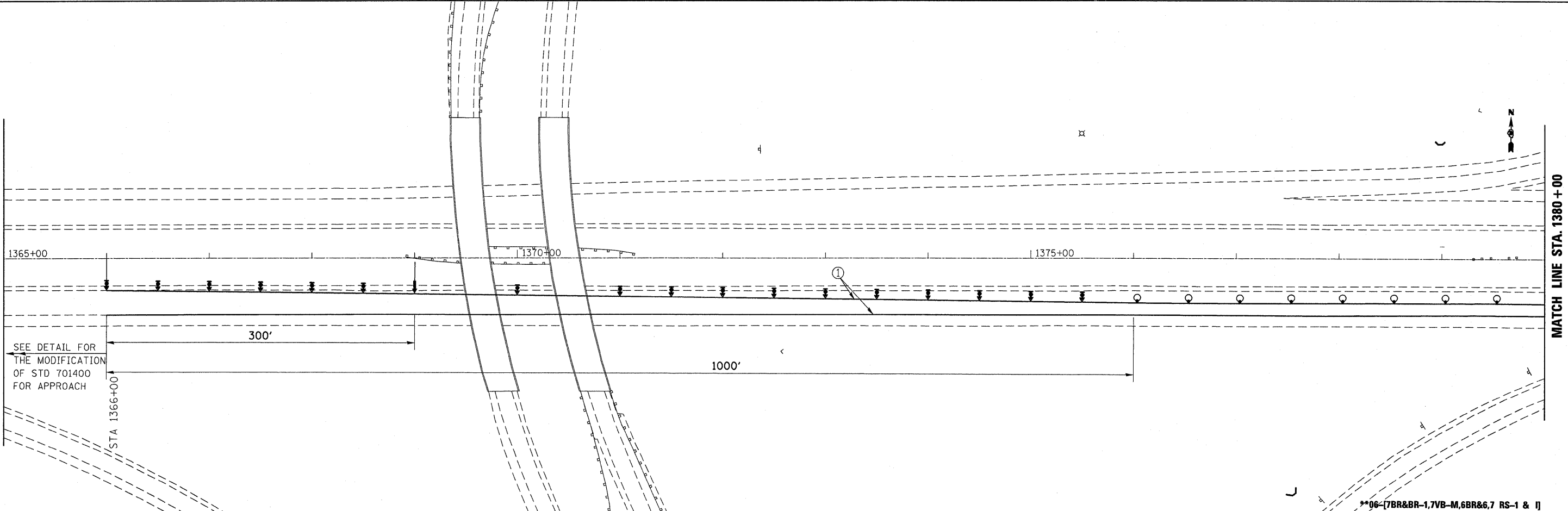

MATCH LINE STA. 1365+00

MATCH LINE STA. 1380+00

SEE DETAIL FOR THE MODIFICATION OF STD 701400 FOR APPROACH

STA 1366+00

300'

1000'

\*\*06-(7BR&BR-1,7VB-M,6BR&6,7 RS-1 & 1)

FILE NAME =	USER NAME = braboypc	DESIGNED -	REVISED -
c:\pwork\PWIDDT\BRABOYPC\d0112640\d368908-shr-staging.dgn		DRAWN -	REVISED -
	PLOT SCALE = 50.0000' / IN.	CHECKED -	REVISED -
	PLOT DATE = Sep 07, 2009 - 01:13:27 PM	DATE -	REVISED -

STATE OF ILLINOIS  
DEPARTMENT OF TRANSPORTATION

STAGE I CONSTRUCTION

SCALE: SHEET NO. OF SHEETS STA. TO STA.

F.A. RTE.	SECTION	COUNTY	TOTAL SHEETS	SHEET NO.
I-80	**	BUREAU	344	58
CONTRACT NO. 66908				
ILLINOIS FED. AID PROJECT				

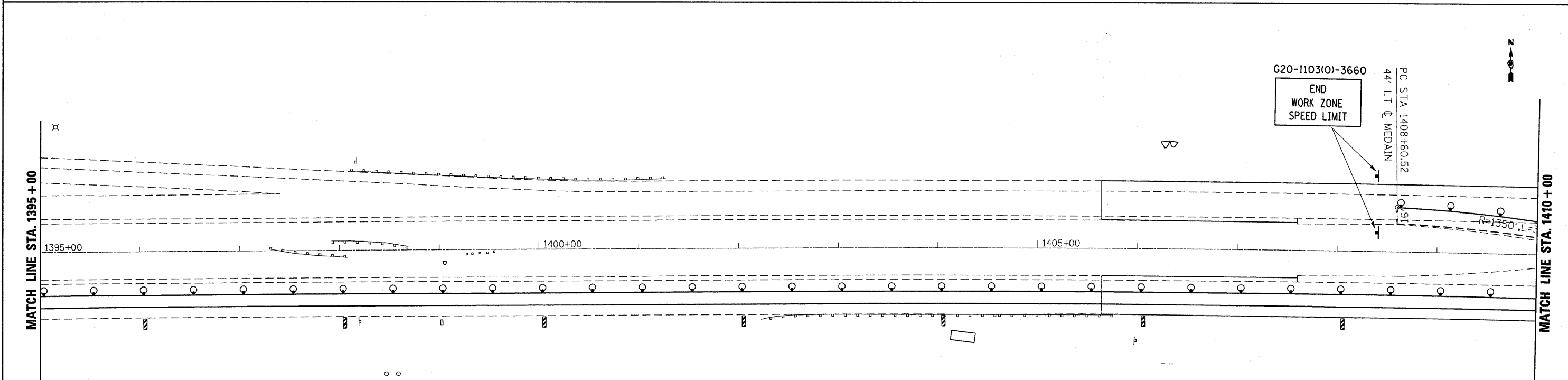
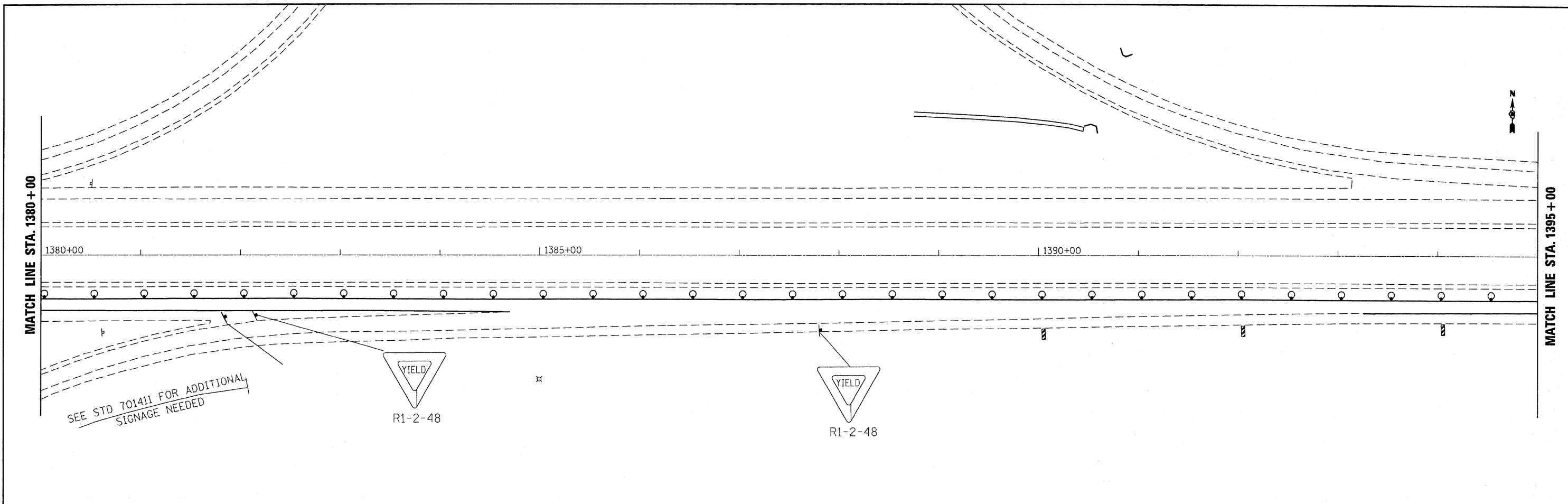

SYMBOLS

- Vertical Panel (back to back)
- Arrow board
- Sign
- Direction indicator barricade with steady burn monodirectional light
- Drum with steady burn monodirectional light
- Type II barricade, drum, or vertical barricade with steady burn monodirectional light
- Wet temporary pavement marking tape - TY III shall be placed throughout the taper and along-side the work area. The edge lines shall be white and the line near the barrier shall be yellow.

FILE NAME =	USER NAME = braboypc	DESIGNED -	REVISED -
c:\pwork\FW1001\BRABOYPC\d0112640\d365908-shit-staging.dgn		DRAWN -	REVISED -
	PLOT SCALE = 50.0000 / IN.	CHECKED -	REVISED -
	PLOT DATE = Sep 07, 2009 - 01:13:17 PM	DATE -	REVISED -

STATE OF ILLINOIS  
DEPARTMENT OF TRANSPORTATION

STAGE I CONSTRUCTION

SCALE: SHEET NO. OF SHEETS STA. TO STA.

F.A. RTE.	SECTION	COUNTY	TOTAL SHEETS	SHEET NO.
I-80	**	BUREAU	344	59
CONTRACT NO. 66908				
ILLINOIS FED. AID PROJECT				

\*\*06-[7BR&BR-1,7VB-M,6BR&6,7 RS-1 & I]

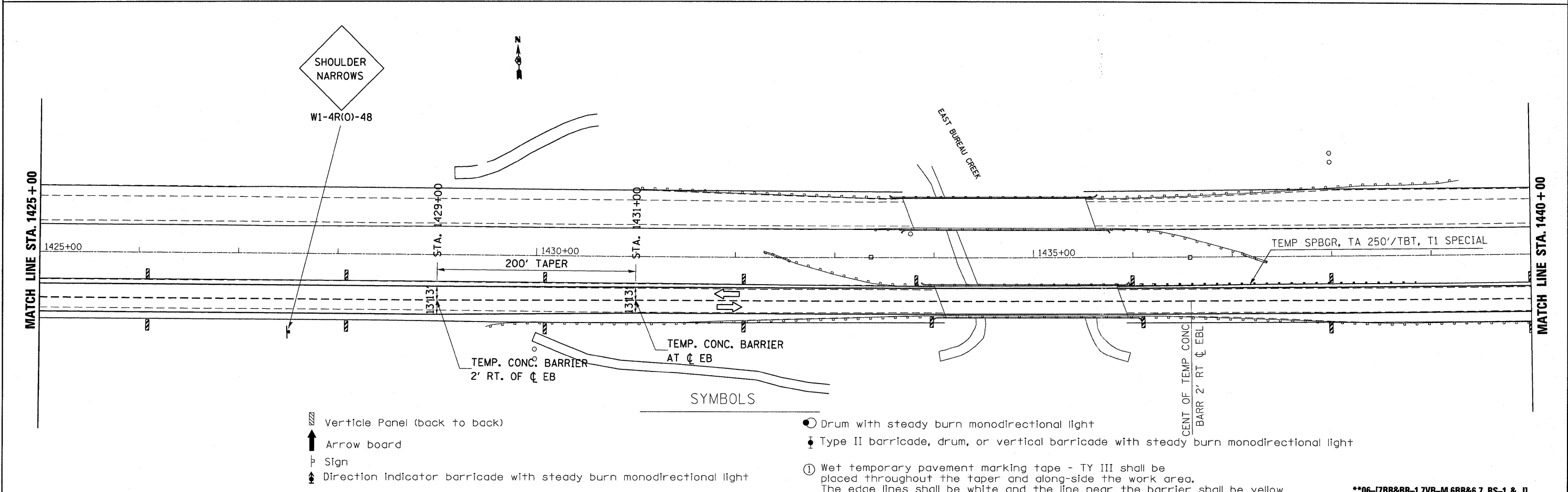
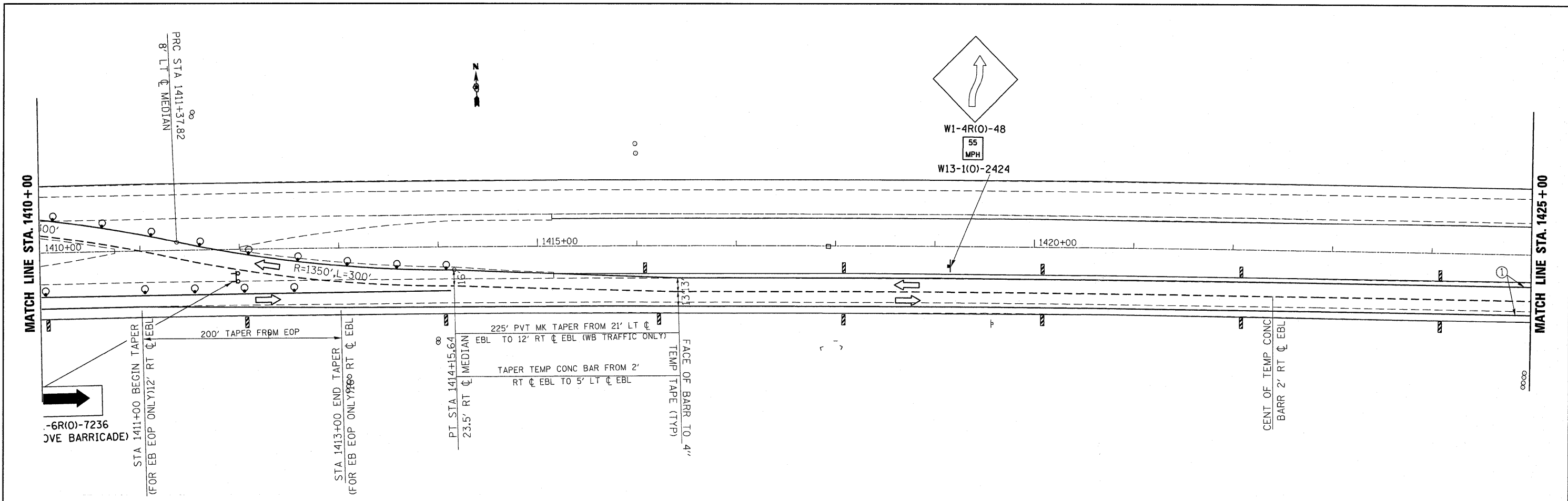

- SYMBOLS**
- Vertical Panel (back to back)
  - Arrow board
  - Sign
  - Direction Indicator barricade with steady burn monodirectional light
  - Drum with steady burn monodirectional light
  - Type II barricade, drum, or vertical barricade with steady burn monodirectional light
  - Wet temporary pavement marking tape - TY III shall be placed throughout the taper and along-side the work area. The edge lines shall be white and the line near the barrier shall be yellow.

FILE NAME =	USER NAME = braboypc	DESIGNED -	REVISED -	<b>STATE OF ILLINOIS DEPARTMENT OF TRANSPORTATION</b>	<b>STAGE I CONSTRUCTION</b>				F.A. RTE.	SECTION	COUNTY	TOTAL SHEETS	SHEET NO.		
c:\pwork\p\1001\BRABOYPC\d0112640\365908-sht-staging.dgn		DRAWN -	REVISED -		SCALE:	SHEET NO.	OF	SHEETS	STA.	TO STA.	I-80	**	BUREAU	344	60
		CHECKED -	REVISED -		CONTRACT NO. 66908										
		DATE -	REVISED -		ILLINOIS FED. AID PROJECT										

\*\*06-[7BR&BR-1,7VB-M,6BR&6,7 RS-1 & I]

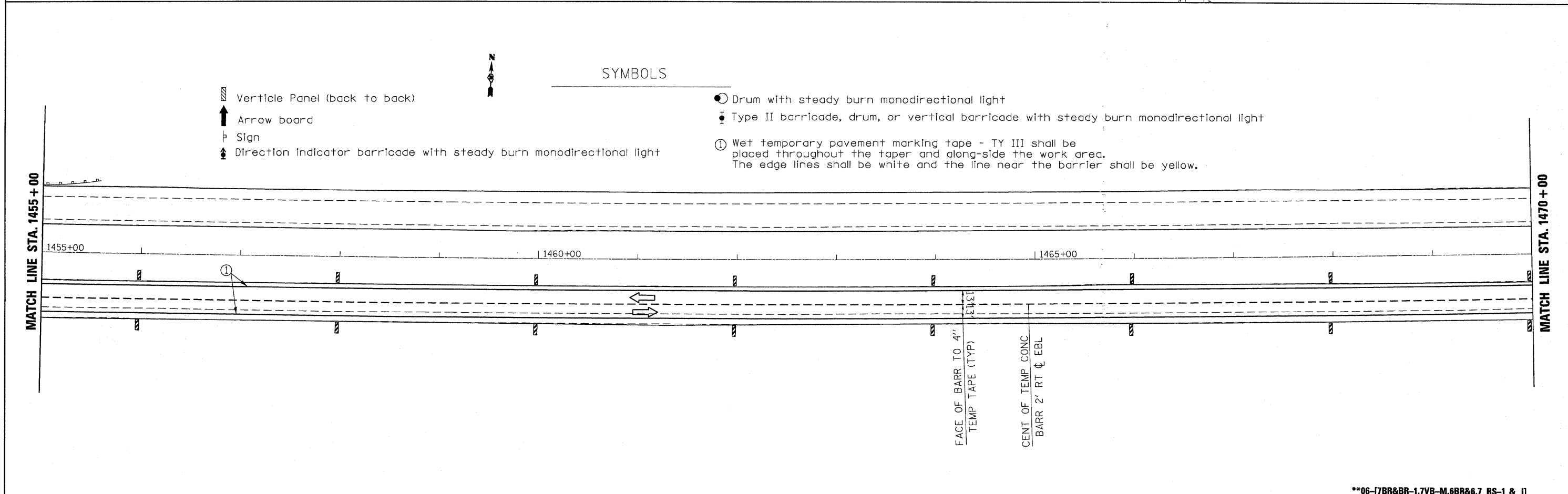
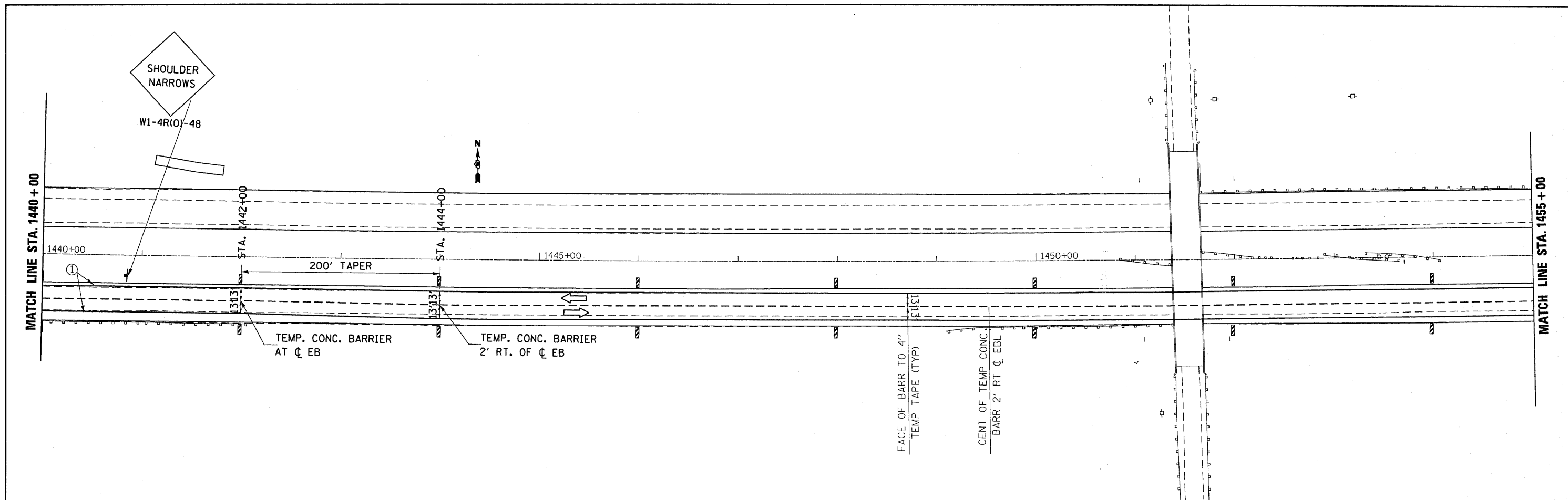

- Vertical Panel (back to back)
- Arrow board
- Sign
- Direction indicator barricade with steady burn monodirectional light

**SYMBOLS**







- Drum with steady burn monodirectional light
- Type II barricade, drum, or vertical barricade with steady burn monodirectional light
- Wet temporary pavement marking tape - TY III shall be placed throughout the taper and along-side the work area. The edge lines shall be white and the line near the barrier shall be yellow.

FILE NAME =	USER NAME = braboypc	DESIGNED -	REVISED -	<b>STATE OF ILLINOIS DEPARTMENT OF TRANSPORTATION</b>	<b>STAGE I CONSTRUCTION</b>	F.A. RTE.	SECTION	COUNTY	TOTAL SHEETS	SHEET NO.	
c:\pwwork\FWIDOT\BRABOYPC\d0112640\d385908-shr-staging.dgn	PLLOT SCALE = 50.0000' / IN.	DRAWN -	REVISED -			1-80	**	BUREAU	344	61	
PLLOT DATE = Sep 07, 2009 - 01:13:02 PM	DATE -	CHECKED -	REVISED -			CONTRACT NO. 66908					
						ILLINOIS FED. AID PROJECT					

\*\*06-[7BR&BR-1,7VB-M,6BR&6,7 RS-1 & I]

SCALE: SHEET NO. OF SHEETS STA. TO STA.

SYMBOLS

-  Verticle Panel (back to back)
-  Arrow board
-  Sign
-  Direction indicator barricade with steady burn monodirectional light
-  Drum with steady burn monodirectional light
-  Type II barricade, drum, or vertical barricade with steady burn monodirectional light
-  ① Wet temporary pavement marking tape - TY III shall be placed throughout the taper and along-side the work area. The edge lines shall be white and the line near the barrier shall be yellow.

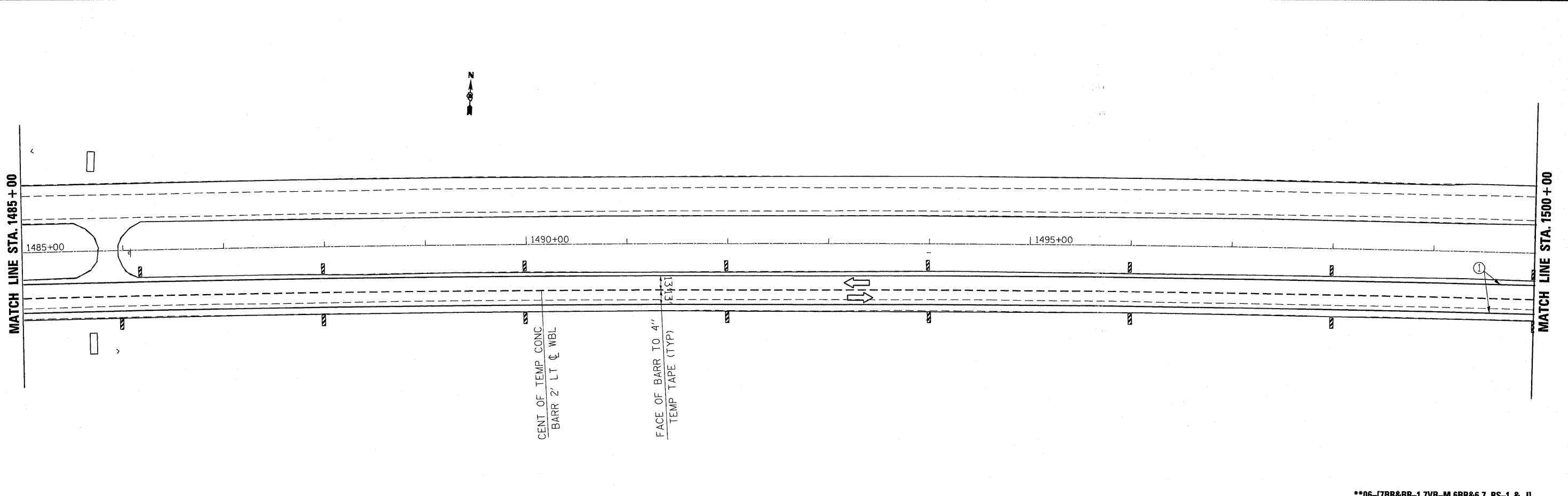
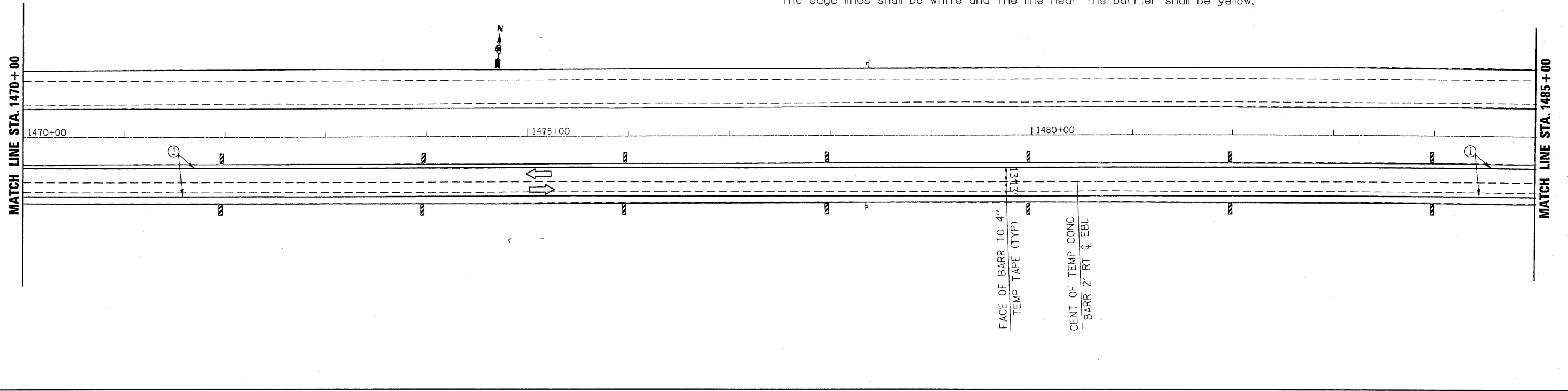

\*\*06-[7BR&BR-1,7VB-M,6BR&6,7 RS-1 & IJ]

FILE NAME =	USER NAME = braboypc	DESIGNED -	REVISED -	<b>STATE OF ILLINOIS DEPARTMENT OF TRANSPORTATION</b>	<b>STAGE I CONSTRUCTION</b>				F.A. RTE.	SECTION	COUNTY	TOTAL SHEETS	SHEET NO.		
o:\pwwork\FWIDOT\BRABOYPC\d0112640\d365908-shr-staging.dgn	PLOT SCALE = 50.0000' / IN.	DRAWN -	REVISED -		SCALE:	SHEET NO.	OF	SHEETS	STA.	TO STA.	I-80	**	BUREAU	344	62
PLOT DATE = Sep 07, 2009 - 01:12:50 PM	DATE -	CHECKED -	REVISED -		CONTRACT NO. 66908										
					ILLINOIS FED. AID PROJECT										

SYMBOLS

- ▨ Verticle Panel (back to back)
- ↑ Arrow board
- ⊥ Sign
- ⬇ Direction indicator barricade with steady burn monodirectional light
- Drum with steady burn monodirectional light
- ⬇ Type II barricade, drum, or vertical barricade with steady burn monodirectional light
- ① Wet temporary pavement marking tape - TY III shall be placed throughout the taper and along-side the work area. The edge lines shall be white and the line near the barrier shall be yellow.

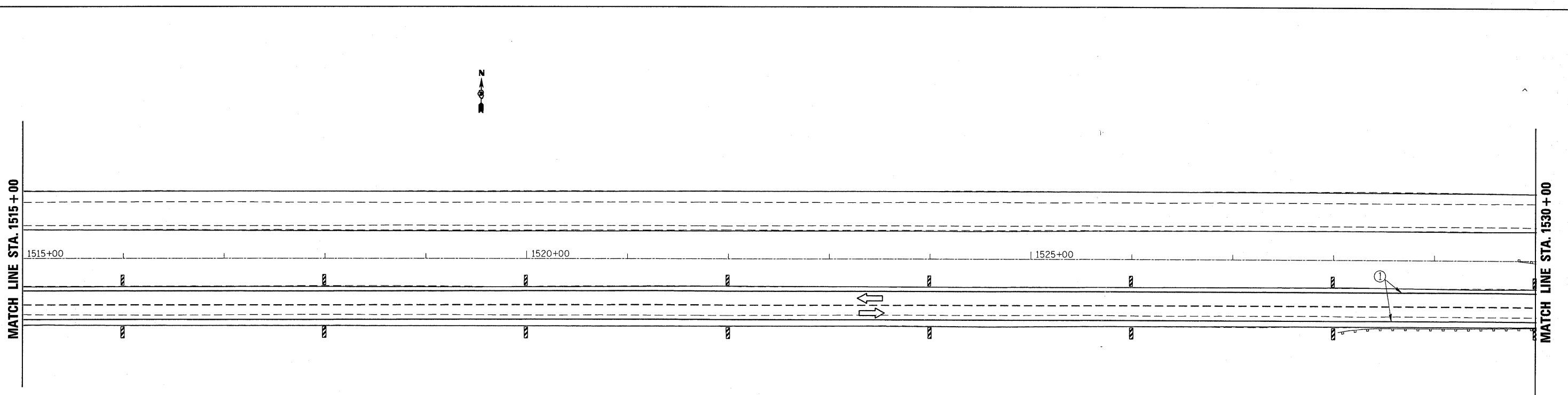
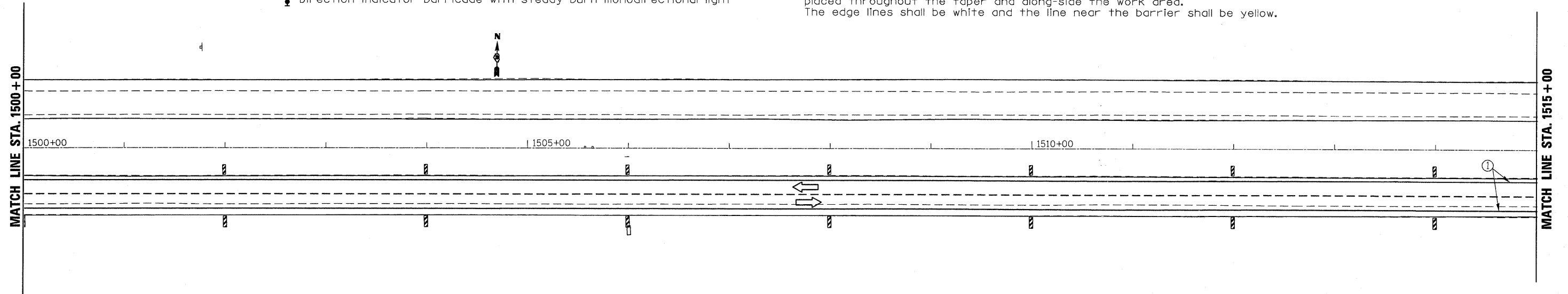

\*\*06-[7BR&BR-1,7VB-M,6BR&6,7 RS-1 & I]

FILE NAME =	USER NAME = braboypc	DESIGNED -	REVISED -
c:\pwork\PWIDOT\BRABOYPC\d0112640\d365908-shit-staging.dgn		DRAWN -	REVISED -
PLOT SCALE = 50.0000' / IN.		CHECKED -	REVISED -
PLOT DATE = Sep 07, 2009 - 01:12:43 PM		DATE -	REVISED -

STATE OF ILLINOIS  
DEPARTMENT OF TRANSPORTATION

STAGE I CONSTRUCTION

SCALE: SHEET NO. OF SHEETS STA. TO STA.

F.A. RTE.	SECTION	COUNTY	TOTAL SHEETS	SHEET NO.
1-80	**	BUREAU	344	63
CONTRACT NO. 66908			ILLINOIS FED. AID PROJECT	

SYMBOLS

- ▨ Vertical Panel (back to back)
- ↑ Arrow board
- ⊥ Sign
- ⬇ Direction Indicator barricade with steady burn monodirectional light
- Drum with steady burn monodirectional light
- ⬇ Type II barricade, drum, or vertical barricade with steady burn monodirectional light
- ① Wet temporary pavement marking tape - TY III shall be placed throughout the taper and along-side the work area. The edge lines shall be white and the line near the barrier shall be yellow.

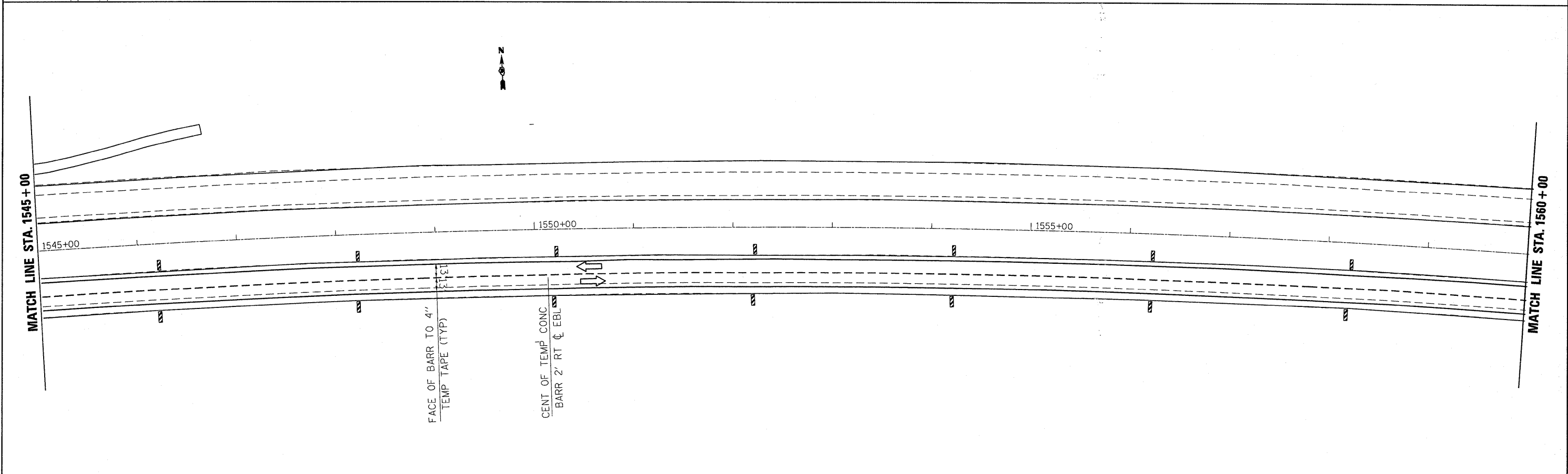
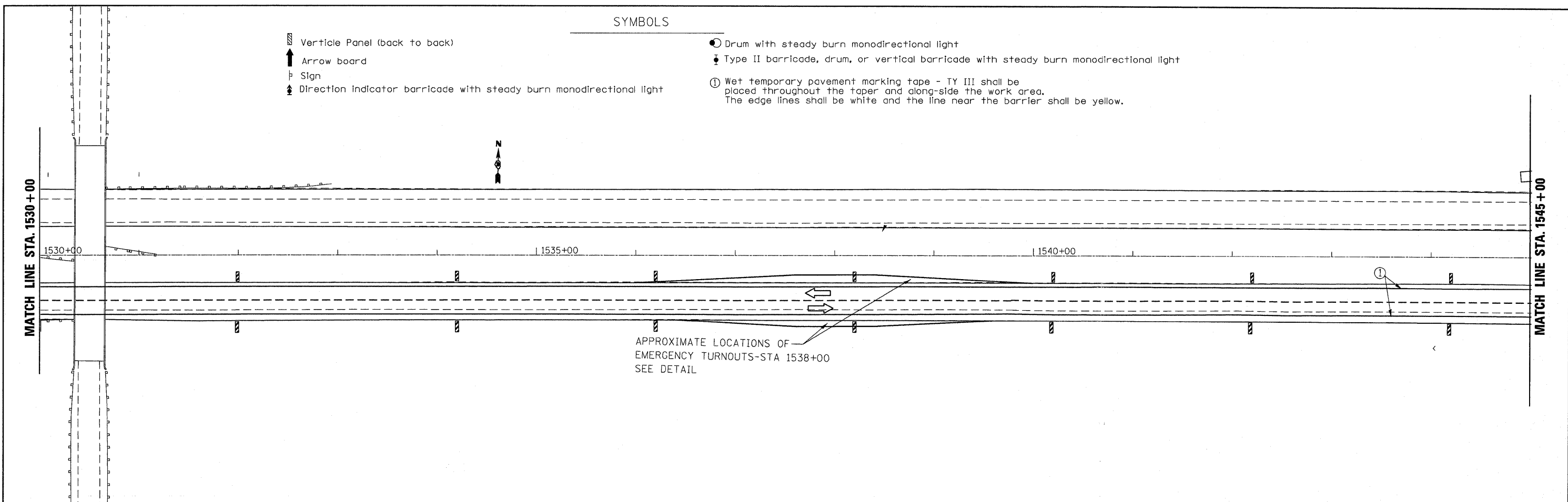

FILE NAME =	USER NAME = braboypc	DESIGNED -	REVISED -	<b>STATE OF ILLINOIS DEPARTMENT OF TRANSPORTATION</b>	<b>STAGE I CONSTRUCTION</b>	F.A. RTE.	SECTION	COUNTY	TOTAL SHEETS	SHEET NO.	
c:\pwork\PWIDOT\BRABOYPC\d0112640\d365708-shr-staging.dgn	PLOT SCALE = 50.0000' / IN.	DRAWN -	REVISED -			1-80	**	BUREAU	344	64	
PLOT DATE = Sep 07, 2009 - 01:12:35 PM	DATE -	CHECKED -	REVISED -			CONTRACT NO. 66908					
						ILLINOIS FED. AID PROJECT					

\*\*06-(7BR&BR-1,7VB-M,6BR&6,7 RS-1 & I)



SYMBOLS

- ▨ Vertical Panel (back to back)
- ↑ Arrow board
- ⊥ Sign
- ↔ Direction Indicator barricade with steady burn monodirectional light

- Drum with steady burn monodirectional light
- ⊥ Type II barricade, drum, or vertical barricade with steady burn monodirectional light
- ① Wet temporary pavement marking tape - TY III shall be placed throughout the taper and along-side the work area. The edge lines shall be white and the line near the barrier shall be yellow.

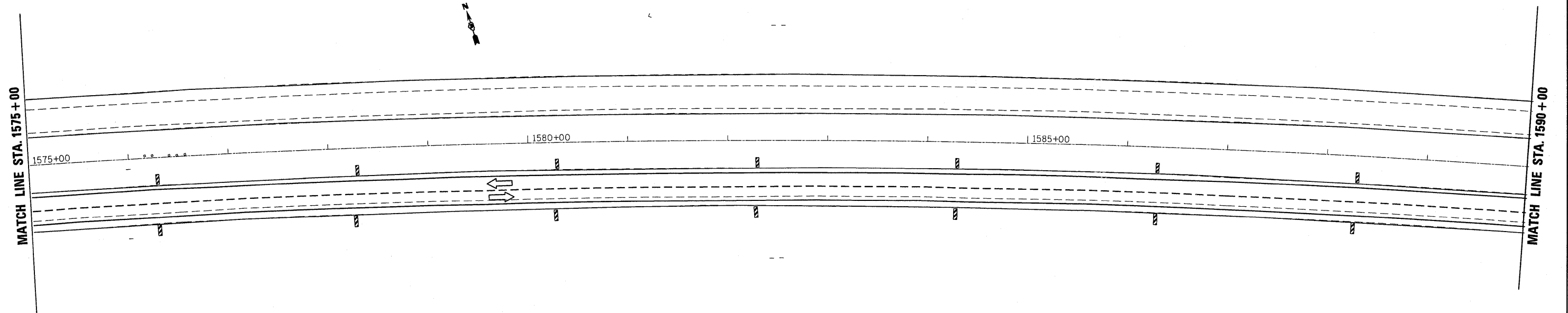
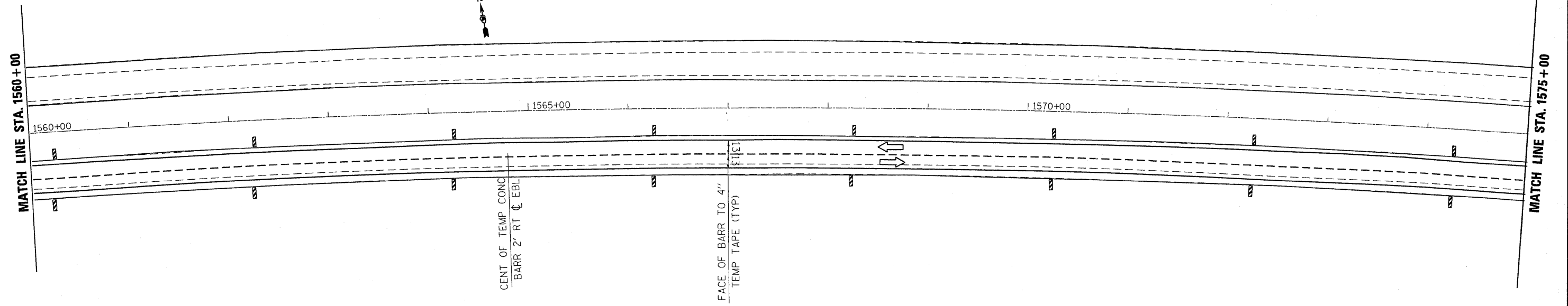

FILE NAME =	USER NAME = braboypc	DESIGNED -	REVISED -
c:\pw_work\PIWIDOT\BRABOYPC\d0112640\365908-sht-staging.dgn		DRAWN -	REVISED -
	PLLOT SCALE = 50.0000' / IN.	CHECKED -	REVISED -
	PLLOT DATE = Sep 07, 2009 - 01:12:25 PM	DATE -	REVISED -

STATE OF ILLINOIS  
DEPARTMENT OF TRANSPORTATION

STAGE I CONSTRUCTION

SCALE: SHEET NO. OF SHEETS STA. TO STA.

\*\*06-[7BR&BR-1.7VB-M,6BR&6.7 RS-1 & I]

F.A. RTE.	SECTION	COUNTY	TOTAL SHEETS	SHEET NO.
I-80	**	BUREAU	344	65
CONTRACT NO. 66908				
ILLINOIS FED. AID PROJECT				

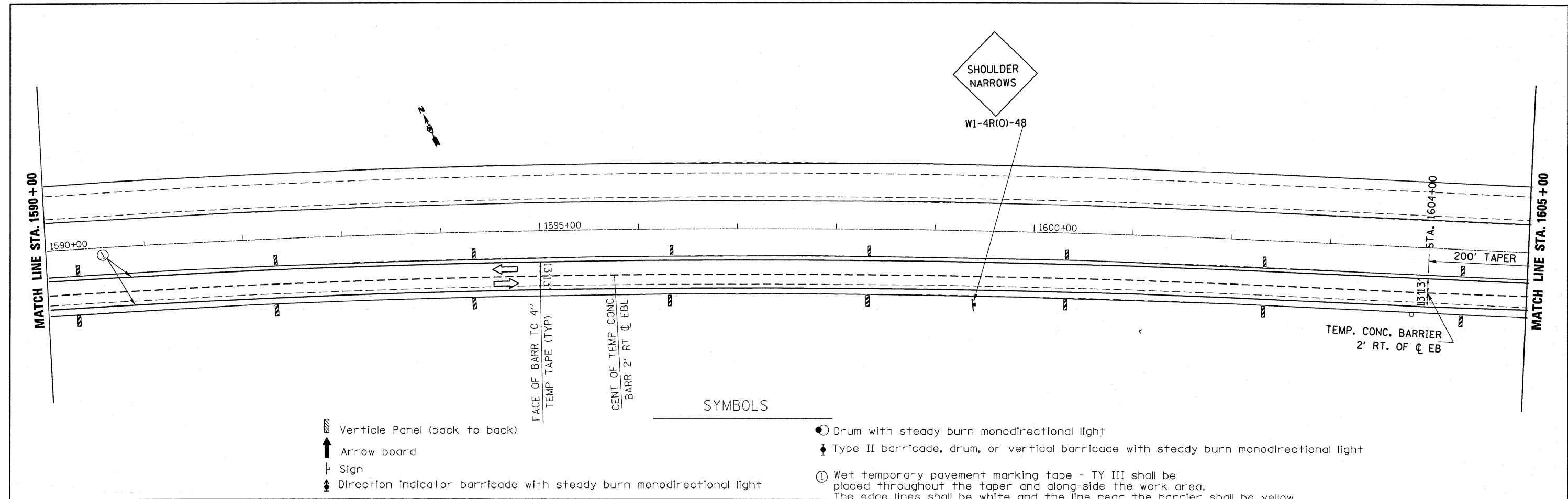

- SYMBOLS
- Vertical Panel (back to back)
  - Arrow board
  - Sign
  - Direction indicator barricade with steady burn monodirectional light
  - Drum with steady burn monodirectional light
  - Type II barricade, drum, or vertical barricade with steady burn monodirectional light
  - Wet temporary pavement marking tape - TY III shall be placed throughout the taper and along-side the work area. The edge lines shall be white and the line near the barrier shall be yellow.

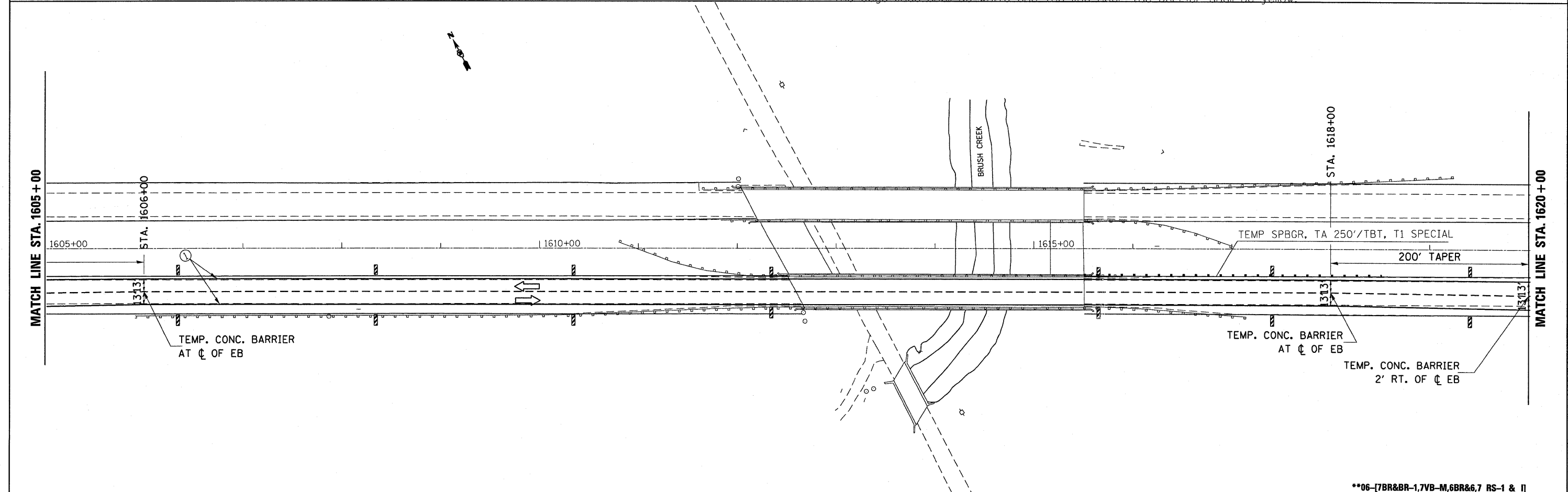

FILE NAME =	USER NAME = braboypc	DESIGNED -	REVISED -	<b>STATE OF ILLINOIS DEPARTMENT OF TRANSPORTATION</b>	<b>STAGE I CONSTRUCTION</b>	F.A. RTE.	SECTION	COUNTY	TOTAL SHEETS	SHEET NO.	
cr:\pwork\PWIDDT\BRABOYPC\d0112640\365908-shr-staging.dgn	DRAWN -	REVISED -	REVISED -			I-80	**	BUREAU	344	66	
PLDT SCALE = 50.0000' / IN.	CHECKED -	REVISED -	REVISED -			CONTRACT NO. 66908					
PLDT DATE = Sep 07, 2009 - 01:12:17 PM	DATE -	REVISED -	REVISED -			ILLINOIS FED. AID PROJECT					



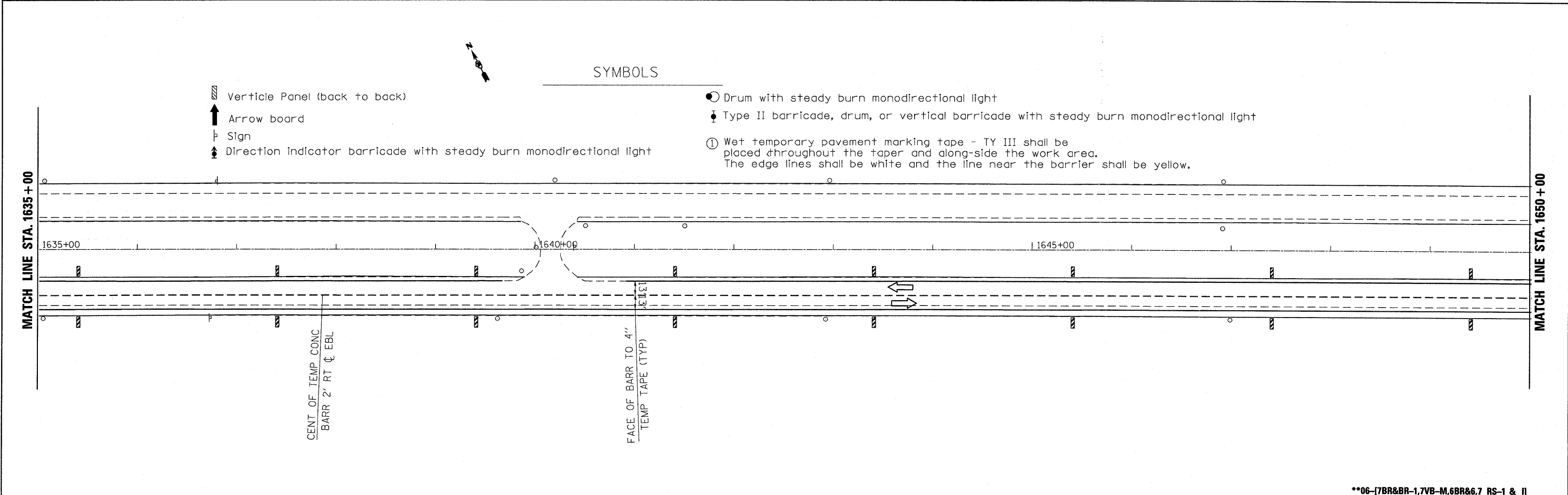
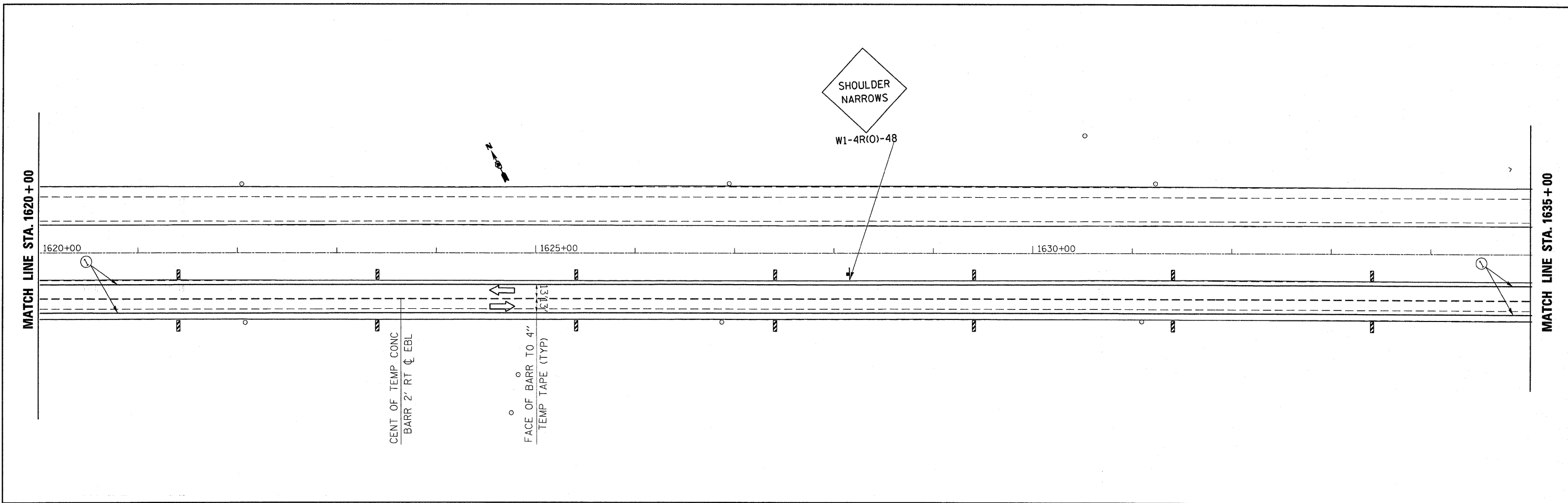



\*\*06-[7BR&BR-1,7VB-M,6BR&6,7 RS-1 & I]



FILE NAME =				USER NAME = braboypc				DESIGNED -				REVISED -				<b>STATE OF ILLINOIS</b> <b>DEPARTMENT OF TRANSPORTATION</b>				<b>STAGE I CONSTRUCTION</b>				F.A. RTE.		SECTION		COUNTY		TOTAL SHEETS		SHEET NO.	
c:\pwork\pwidot\BRABOYPC\d0112640\d365908-shr-staging.dgn				DRAWN -				REVISED -				I-80		**										BUREAU		344		67					
PLOT SCALE = 50.0000' / IN.				CHECKED -				REVISED -				CONTRACT NO. 66908												ILLINOIS FED. AID PROJECT									
PLOT DATE = Sep 07, 2009 - 01:12:09 PM				DATE -				REVISED -				SCALE:												SHEET NO.		OF SHEETS		STA.		TO STA.			

\*\*06-[7BR&BR-1,7VB-M,6BR&6,7 RS-1 & I]

SYMBOLS



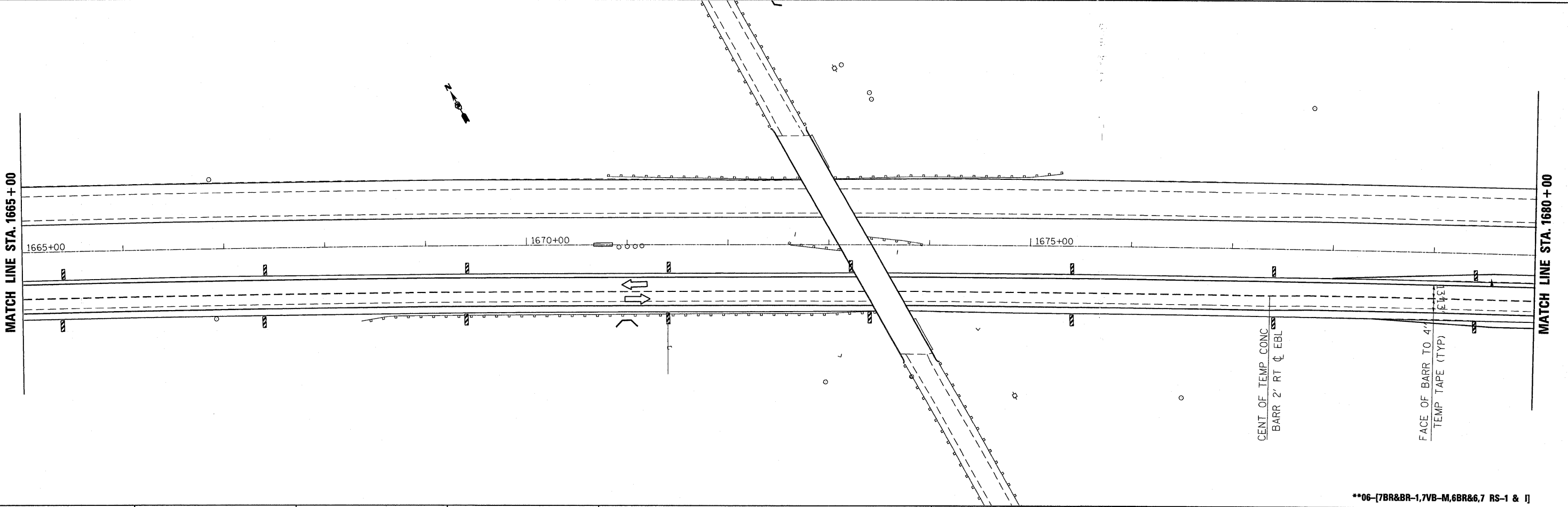
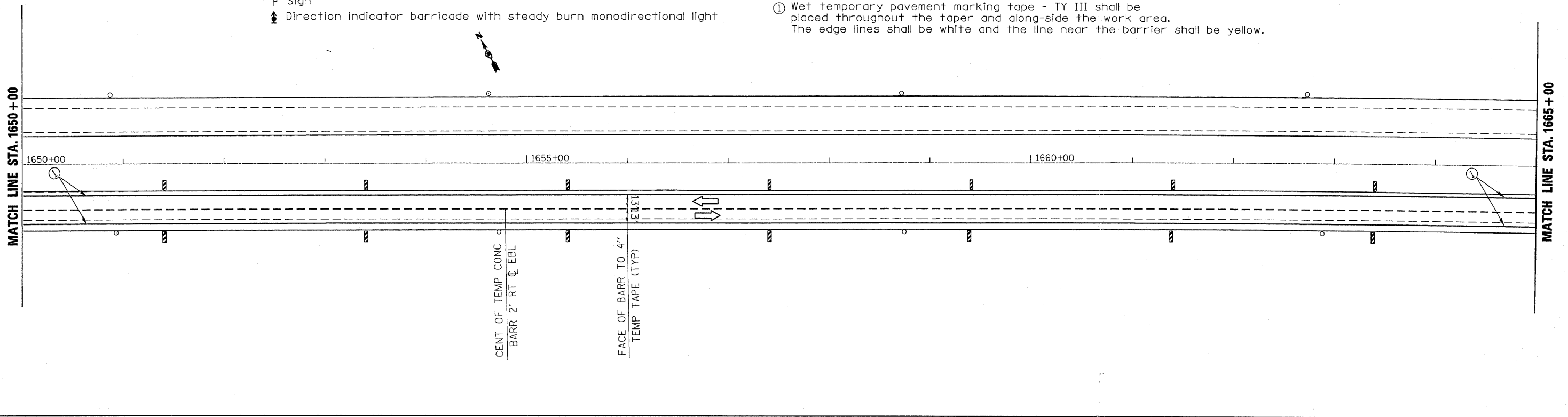

-  Verticle Panel (back to back)
-  Arrow board
-  Sign
-  Direction indicator barricade with steady burn monodirectional light
-  Drum with steady burn monodirectional light
-  Type II barricade, drum, or vertical barricade with steady burn monodirectional light
-  ① Wet temporary pavement marking tape - TY III shall be placed throughout the taper and along-side the work area. The edge lines shall be white and the line near the barrier shall be yellow.





FILE NAME =	USER NAME = braboypc	DESIGNED -	REVISED -	<b>STATE OF ILLINOIS DEPARTMENT OF TRANSPORTATION</b>	<b>STAGE I CONSTRUCTION</b>				F.A. RTE.	SECTION	COUNTY	TOTAL SHEETS	SHEET NO.		
ci:\pw_work\PWIDDT\BRABOYPC\d0112640\385908-shr-staging.dgn		DRAWN -	REVISED -		SCALE:	SHEET NO.	OF	SHEETS	STA.	TO STA.	I-80	**	BUREAU	344	68
		CHECKED -	REVISED -											CONTRACT NO. 66908	
		DATE -	REVISED -											ILLINOIS FED. AID PROJECT	

\*\*06-[7BR&BR-1,7VB-M,6BR&6,7 RS-1 & I]

SYMBOLS

-  Verticle Panel (back to back)
-  Arrow board
-  Sign
-  Direction Indicator barricade with steady burn monodirectional light

-  Drum with steady burn monodirectional light
-  Type II barricade, drum, or vertical barricade with steady burn monodirectional light
-  ① Wet temporary pavement marking tape - TY III shall be placed throughout the taper and along-side the work area. The edge lines shall be white and the line near the barrier shall be yellow.

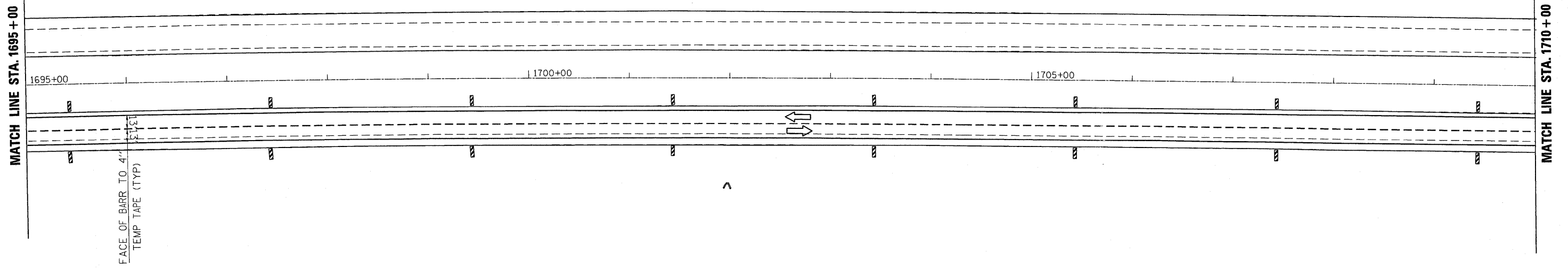
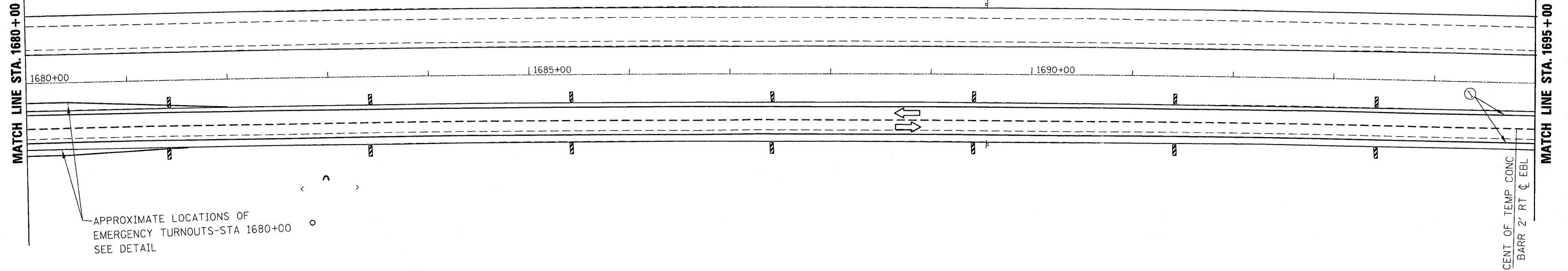

\*\*06-[7BR&BR-1,7VB-M,6BR&6,7 RS-1 & I]

FILE NAME =	USER NAME = braboypc	DESIGNED -	REVISED -
c:\pwwork\FWIDOT\BRABOYPC\d0112640\d365908-shr-staging.dgn		DRAWN -	REVISED -
		CHECKED -	REVISED -
		DATE -	REVISED -

STATE OF ILLINOIS  
DEPARTMENT OF TRANSPORTATION

STAGE I CONSTRUCTION

SCALE: SHEET NO. OF SHEETS STA. TO STA.

F.A. RTE.	SECTION	COUNTY	TOTAL SHEETS	SHEET NO.
I-80	**	BUREAU	344	69
CONTRACT NO. 66908			ILLINOIS FED. AID PROJECT	

SYMBOLS

- ▨ Vertical Panel (back to back)
- ↑ Arrow board
- ⊥ Sign
- ↔ Direction Indicator barricade with steady burn monodirectional light

- Drum with steady burn monodirectional light
- ⊥ Type II barricade, drum, or vertical barricade with steady burn monodirectional light
- ① Wet temporary pavement marking tape - TY III shall be placed throughout the taper and along-side the work area. The edge lines shall be white and the line near the barrier shall be yellow.

MATCH LINE STA. 1710+00

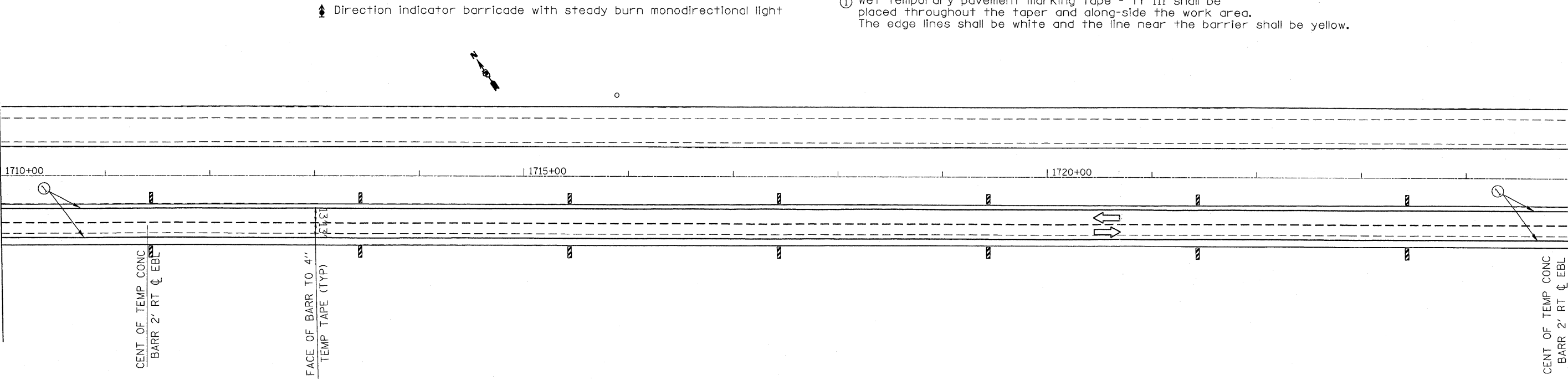

MATCH LINE STA. 1725+00

MATCH LINE STA. 1725+00

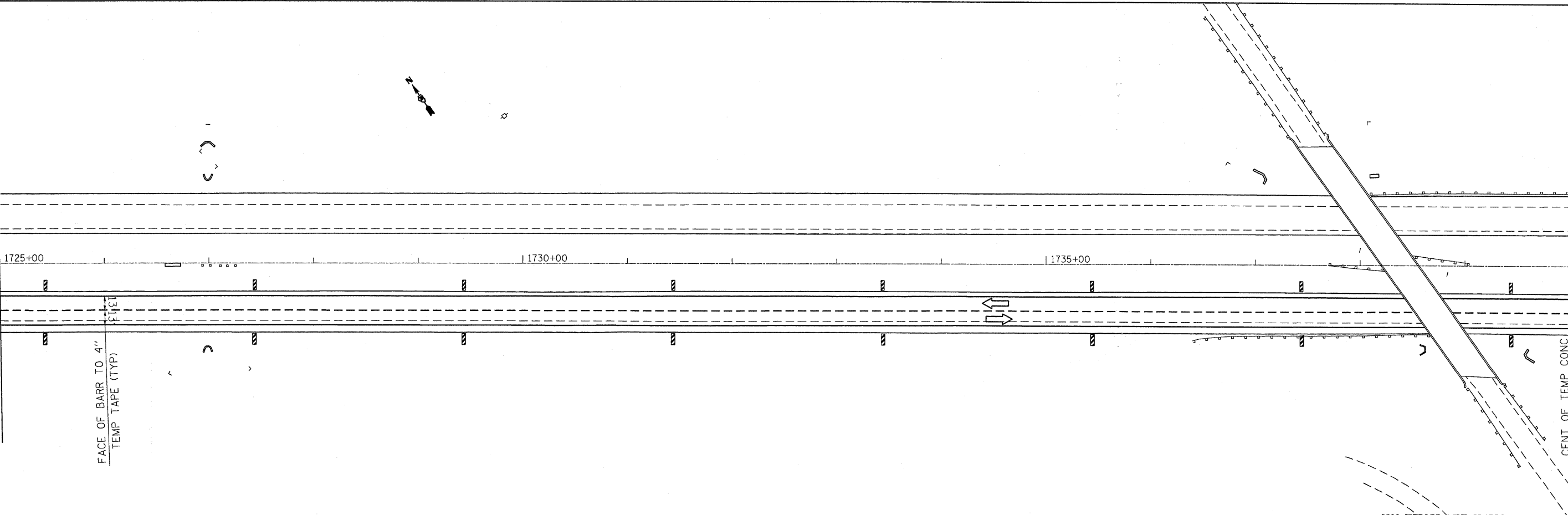

MATCH LINE STA. 1740+00

\*\*06-[7BR&BR-1,7VB-M,6BR&6.7 RS-1 & I]

FILE NAME =	USER NAME = braboypc	DESIGNED -	REVISED -
c:\pwork\PWIDOT\BRABOYPC\d0112640\d365908-shr-staging.dgn		DRAWN -	REVISED -
	PLOT SCALE = 50.0000' / IN.	CHECKED -	REVISED -
	PLOT DATE = Sep 07, 2009 - 01:11:31 PM	DATE -	REVISED -

STATE OF ILLINOIS  
DEPARTMENT OF TRANSPORTATION

STAGE I CONSTRUCTION

SCALE: SHEET NO. OF SHEETS STA. TO STA.

F.A. RTE.	SECTION	COUNTY	TOTAL SHEETS	SHEET NO.
I-80	**	BUREAU	344	70
CONTRACT NO. 66908			ILLINOIS FED. AID PROJECT	

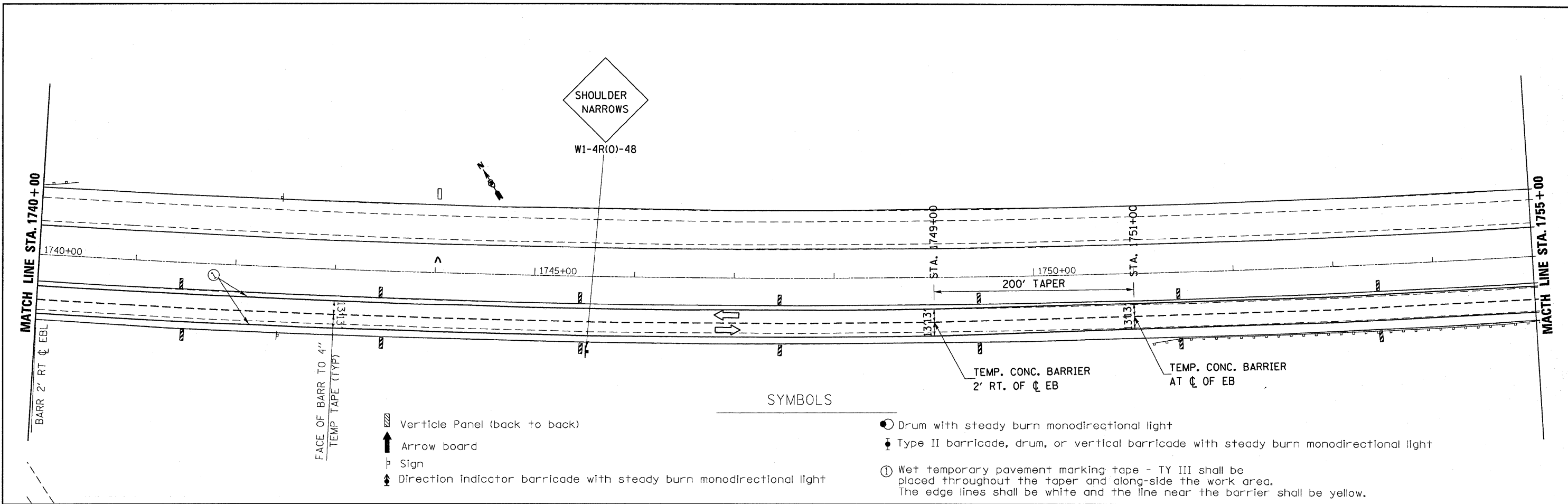

- SYMBOLS
- Vertical Panel (back to back)
  - Arrow board
  - Sign
  - Direction indicator barricade with steady burn monodirectional light
  - Drum with steady burn monodirectional light
  - Type II barricade, drum, or vertical barricade with steady burn monodirectional light
  - Wet temporary pavement marking tape - TY III shall be placed throughout the taper and along-side the work area. The edge lines shall be white and the line near the barrier shall be yellow.

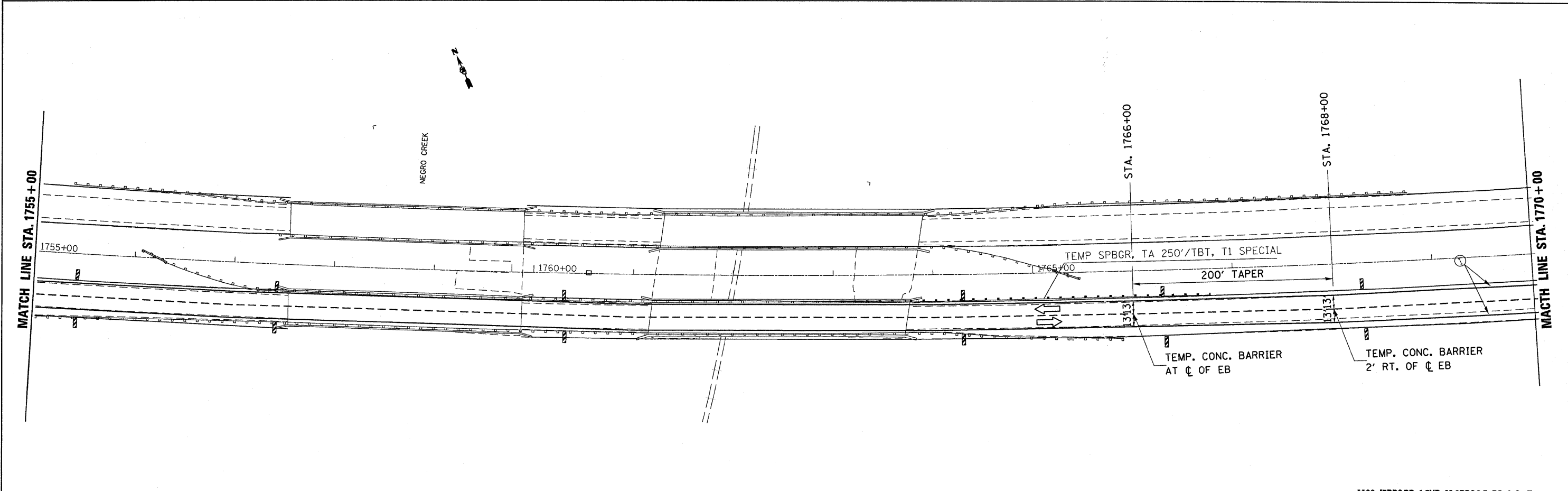

FILE NAME = c:\pwwork\pwwid01\BRABOYPC\d0112640\d365908-shr-staging.dgn				USER NAME = braboypc				DESIGNED - DRAWN - CHECKED - DATE -				REVISED - REVISED - REVISED - REVISED -				<b>STATE OF ILLINOIS DEPARTMENT OF TRANSPORTATION</b>				<b>STAGE I CONSTRUCTION</b>				F.A. RTE. 1-80		SECTION **		COUNTY BUREAU		TOTAL SHEETS 344		SHEET NO. 71	
PLOT SCALE = 50.0000' / IN. PLOT DATE = Sep 07, 2009 - 01:11:19 PM				CONTRACT NO. 66908				ILLINOIS FED. AID PROJECT																									

\*\*06-[7BR&BR-1,7VB-M,6BR&6.7 RS-1 & I]

SYMBOLS

- ▨ Vertical Panel (back to back)
- ↑ Arrow board
- ⊥ Sign
- ↔ Direction indicator barricade with steady burn monodirectional light
- ⊙ Drum with steady burn monodirectional light
- ⊕ Type II barricade, drum, or vertical barricade with steady burn monodirectional light
- ① Wet temporary pavement marking tape - TY III shall be placed throughout the taper and along-side the work area. The edge lines shall be white and the line near the barrier shall be yellow.

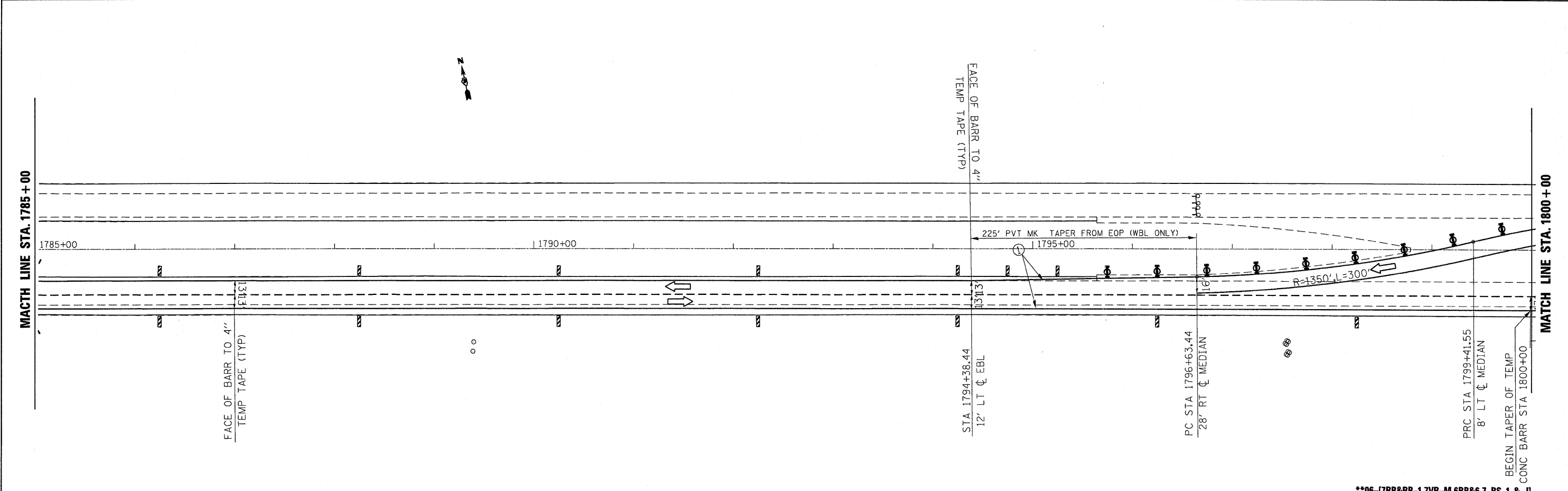
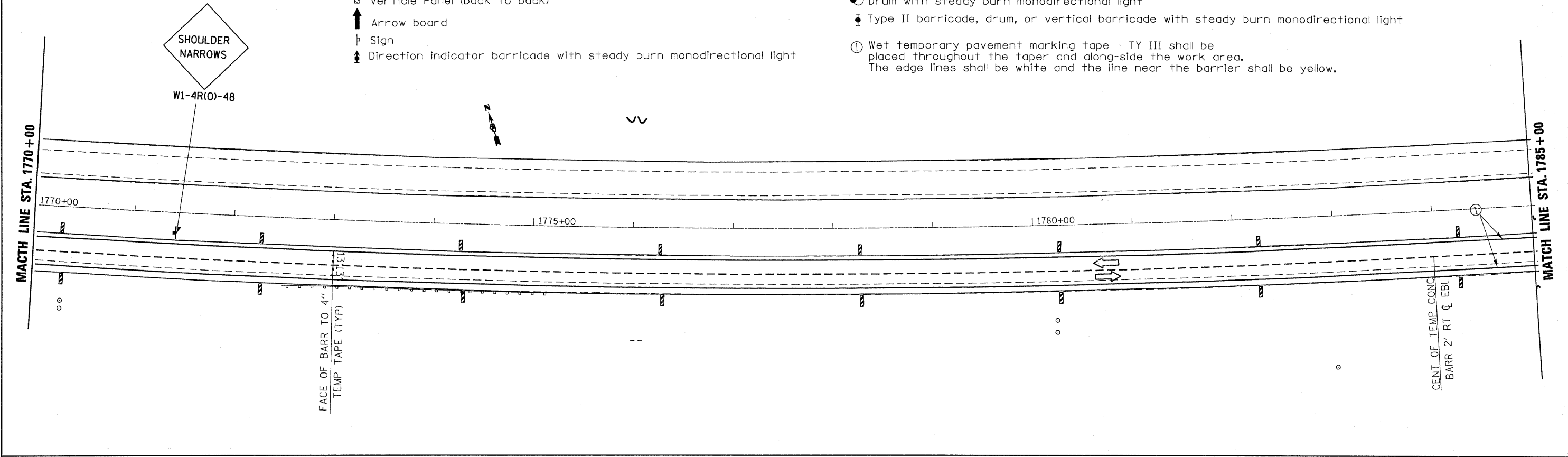

\*\*06-[7BR&BR-1,7VB-M,6BR&6,7 RS-1 & I]

FILE NAME =	USER NAME = breboypc	DESIGNED -	REVISED -	<b>STATE OF ILLINOIS DEPARTMENT OF TRANSPORTATION</b>	<b>STAGE I CONSTRUCTION</b>			F.A. RTE.	SECTION	COUNTY	TOTAL SHEETS	SHEET NO.
c:\pwork\p\WIDOT\BRABOYPC\d0112640\d365908-sht-staging.dgn	PLOT SCALE = 50.0000' / IN.	DRAWN -	REVISED -					I-80	**	BUREAU	344	72
PLOT DATE = Sep 07, 2009 - 01:11:12 PM	DATE -	CHECKED -	REVISED -		SCALE: SHEET NO. OF SHEETS STA. TO STA.			CONTRACT NO. 66908				
		DATE -	REVISED -		ILLINOIS FED. AID PROJECT							



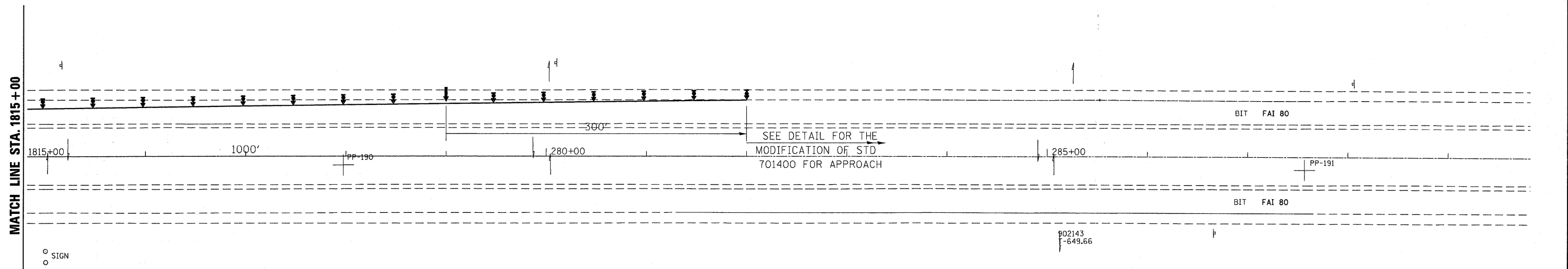
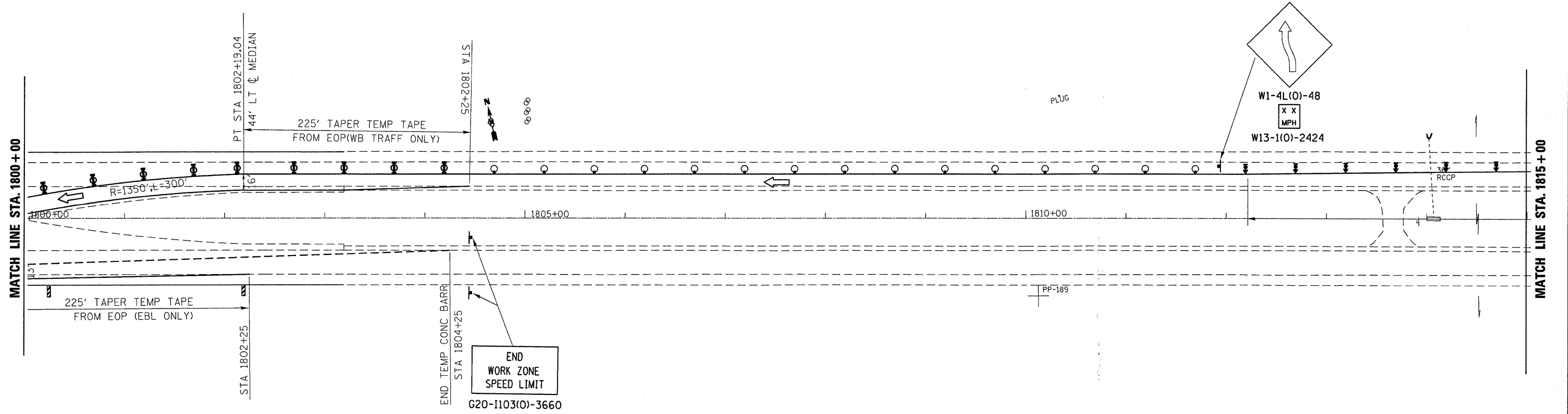

**SYMBOLS**

- Vertical Panel (back to back)
- Arrow board
- Sign
- Direction indicator barricade with steady burn monodirectional light
- Drum with steady burn monodirectional light
- Type II barricade, drum, or vertical barricade with steady burn monodirectional light
- Wet temporary pavement marking tape - TY III shall be placed throughout the taper and along-side the work area. The edge lines shall be white and the line near the barrier shall be yellow.

FILE NAME =	USER NAME = breboypc	DESIGNED -	REVISED -
c:\pwork\pwork\PIWIDOT\BRABOYPC\d0112640\d365908-shr-staging.dgn		DRAWN -	REVISED -
	PLOT SCALE = 50.0000' / IN.	CHECKED -	REVISED -
	PLOT DATE = Sep 07, 2009 - 01:11:02 PM	DATE -	REVISED -

**STATE OF ILLINOIS  
DEPARTMENT OF TRANSPORTATION**

<b>STAGE I CONSTRUCTION</b>				
SCALE:	SHEET NO.	OF SHEETS	STA.	TO STA.

F.A. RTE.	SECTION	COUNTY	TOTAL SHEETS	SHEET NO.
I-80	**	BUREAU	344	73
CONTRACT NO. 66908				
ILLINOIS FED. AID PROJECT				

\*\*06-[7BR&BR-1,7VB-M,6BR&6,7 RS-1 & I]

# BETWEEN MEDIAN CROSSOVERS

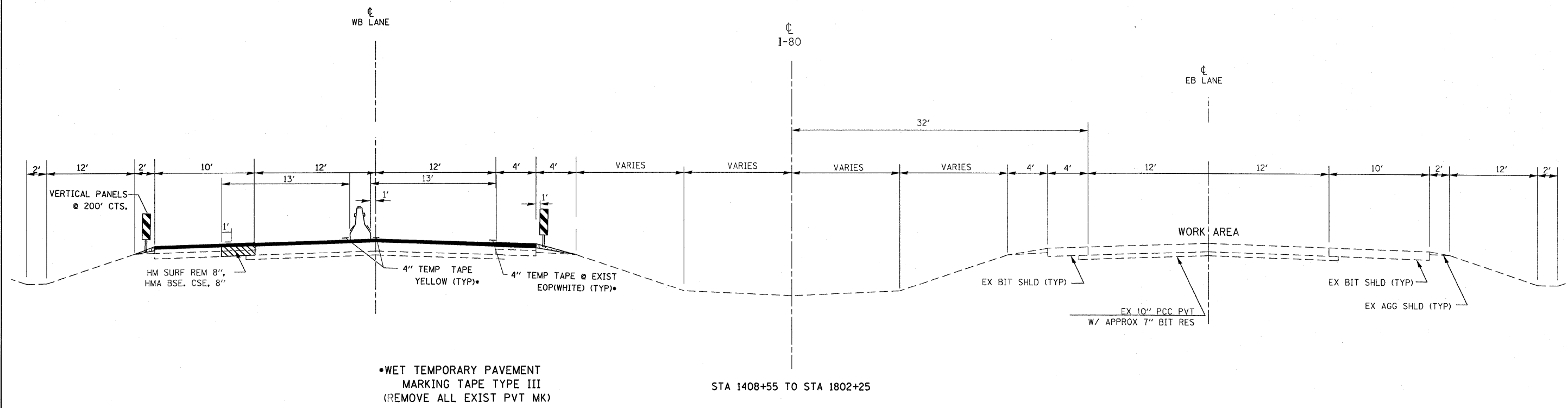

•WET TEMPORARY PAVEMENT  
MARKING TAPE TYPE III  
(REMOVE ALL EXIST PVT MK)

STA 1408+55 TO STA 1802+25

**NOTES:**

1. THE CONTRACTOR HAS THE OPTION OF USING EITHER THE LINE ON THE TEMPORARY CONCRETE BARRIER OR ON THE PAVEMENT.
2. THE COLOR OF THE REFLECTORS AND PAVEMENT/BARRIER MARKING LINE WILL VARY WITH STAGING AND SHALL MATCH THE EXISTING LINE IN THE WORK AREA.
3. THE COST OF THE REFLECTORS IS INCLUDED IN THE COST OF TEMPORARY CONCRETE BARRIER

## STAGE II MAINLINE AND THROUGH BRIDGES

\*\*06-[7BR&BR-1,7VB-M,6BR&6.7 RS-1 & I]

FILE NAME = c:\pwork\pwork\braboypc\d0112640\d366920-sh1-details.DGN	USER NAME = braboypc	DESIGNED -	REVISED -	STATE OF ILLINOIS DEPARTMENT OF TRANSPORTATION	STAGE II CONSTRUCTION TYPICAL SECTIONS	F.A. RTE. I-80	SECTION	COUNTY	TOTAL SHEETS	SHEET NO.
	PLOT SCALE = 50.7353' / IN.	CHECKED -	REVISED -			BUREAU	344	74		
PLOT DATE = Sep 07, 2009 - 02:16:03 PM	DATE -	REVISED -	REVISED -	SCALE: _____	SHEET NO. ___ OF ___ SHEETS	STA. _____ TO STA. _____	CONTRACT NO. 66908			
ILLINOIS FED. AID PROJECT										

SYMBOLS

- ▨ Verticle Panel (back to back)
- ↑ Arrow board
- ⊥ Sign
- ⬇ Direction indicator barricade with steady burn monodirectional light

- Drum with steady burn monodirectional light
- ⊥ Type II barricade, drum, or vertical barricade with steady burn monodirectional light
- ① Wet temporary pavement marking tape - TY III shall be placed throughout the taper and along-side the work area. The edge lines shall be white and the line near the barrier shall be yellow.

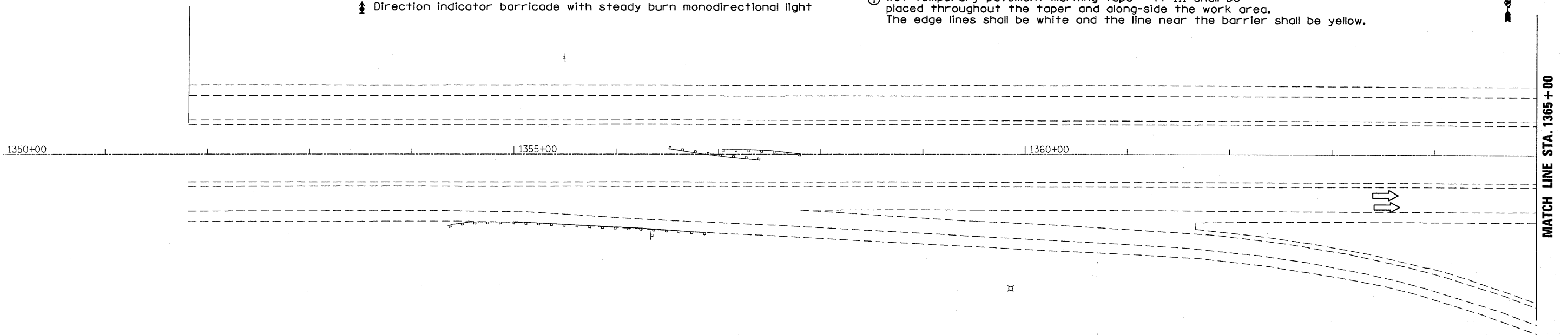

MATCH LINE STA. 1365+00

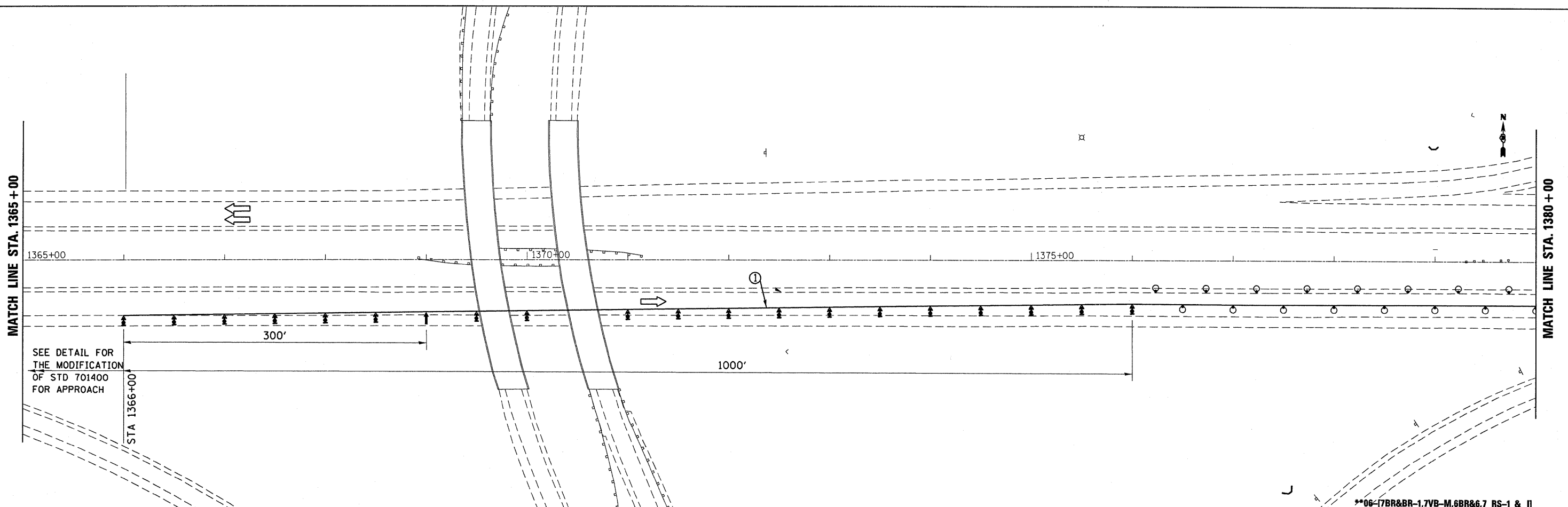

MATCH LINE STA. 1365+00

MATCH LINE STA. 1380+00

SEE DETAIL FOR THE MODIFICATION OF STD 701400 FOR APPROACH

STA 1366+00

300'

1000'

\*\*06-(7BR&BR-1,7VB-M,6BR&6,7 RS-1 & I)

FILE NAME =	USER NAME = braboypc	DESIGNED -	REVISED -
c:\pwork\PW100T\BRABOYPC\d0112640\d365908-shr-staging.dgn		DRAWN -	REVISED -
		CHECKED -	REVISED -
		DATE -	REVISED -
	PLOT SCALE = 50.0000' / IN.		
	PLOT DATE = Sep 07, 2009 - 01:07:33 PM		

STATE OF ILLINOIS  
DEPARTMENT OF TRANSPORTATION

STAGE II CONSTRUCTION

SCALE: SHEET NO. OF SHEETS STA. TO STA.

F.A. RTE.	SECTION	COUNTY	TOTAL SHEETS	SHEET NO.
I-80	**	BUREAU	344	75
			CONTRACT NO. 66908	
ILLINOIS FED. AID PROJECT				

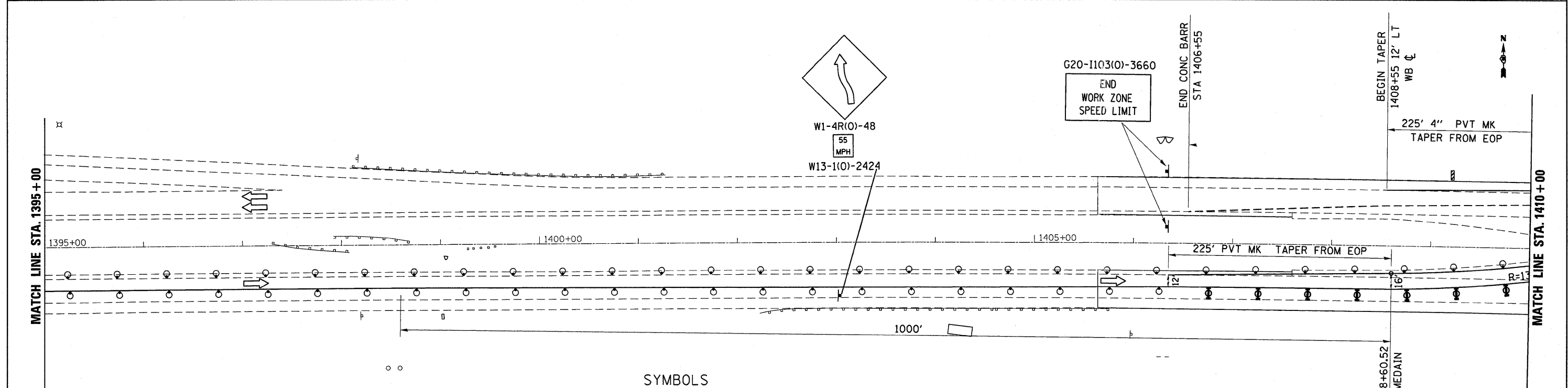
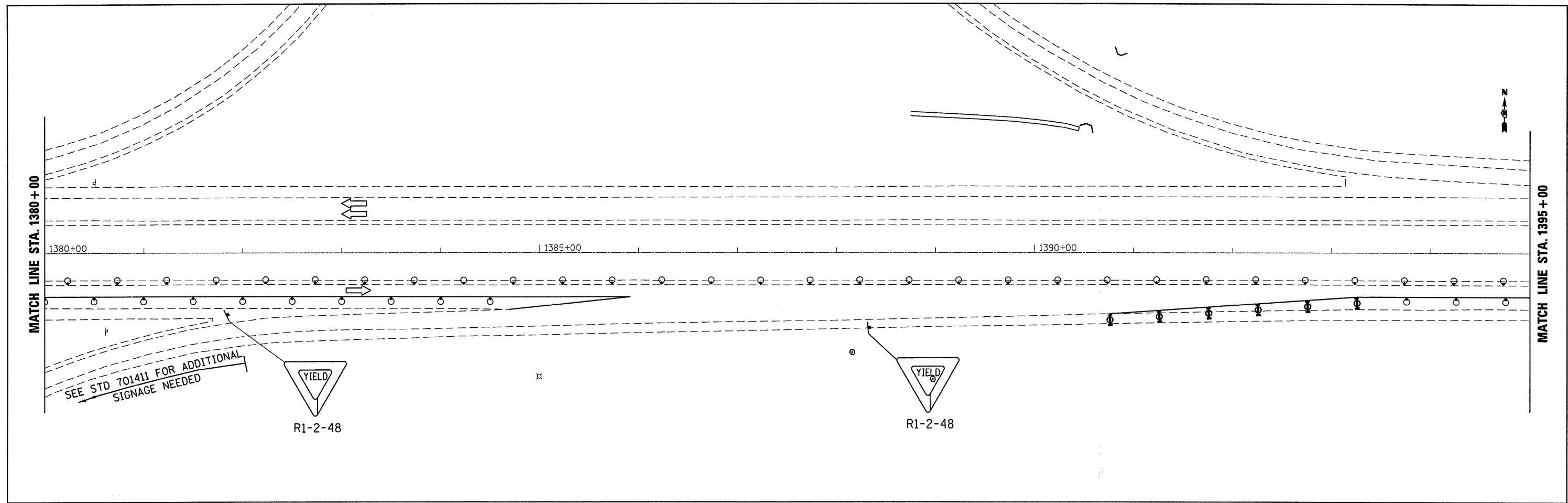

- SYMBOLS**
- Verticle Panel (back to back)
  - Arrow board
  - Sign
  - Direction indicator barricade with steady burn monodirectional light
  - Drum with steady burn monodirectional light
  - Type II barricade, drum, or vertical barricade with steady burn monodirectional light
  - Wet temporary pavement marking tape - TY III shall be placed throughout the taper and along-side the work area. The edge lines shall be white and the line near the barrier shall be yellow.

FILE NAME =	USER NAME = breboypc	DESIGNED -	REVISED -
c:\pwwork\p\1001\BRABOYPC\d0112640\d365908-sht-staging.dgn		DRAWN -	REVISED -
PLOT SCALE = 50.00000' / IN.		CHECKED -	REVISED -
PLOT DATE = Sep 07, 2009 - 01:07:22 PM		DATE -	REVISED -

**STATE OF ILLINOIS  
DEPARTMENT OF TRANSPORTATION**

**STAGE II CONSTRUCTION**

SCALE: SHEET NO. OF SHEETS STA. TO STA.

F.A. RTE.	SECTION	COUNTY	TOTAL SHEETS	SHEET NO.
I-80	**	BUREAU	344	76
CONTRACT NO. 66908			ILLINOIS FED. AID PROJECT	

\*\*06-[7BR&BR-1,7VB-M,6BR&6,7 RS-1 & I]

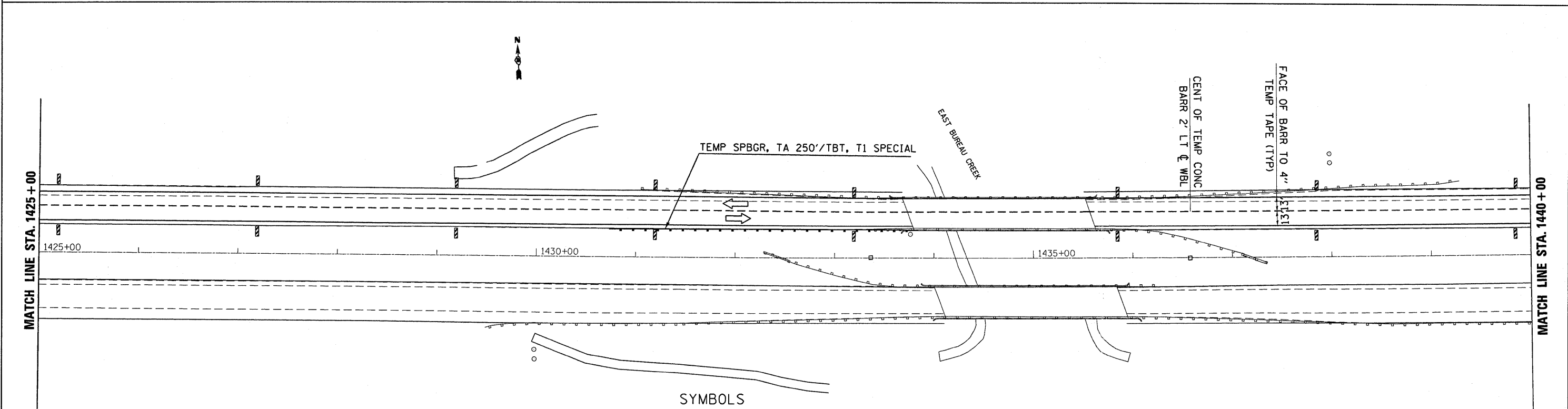
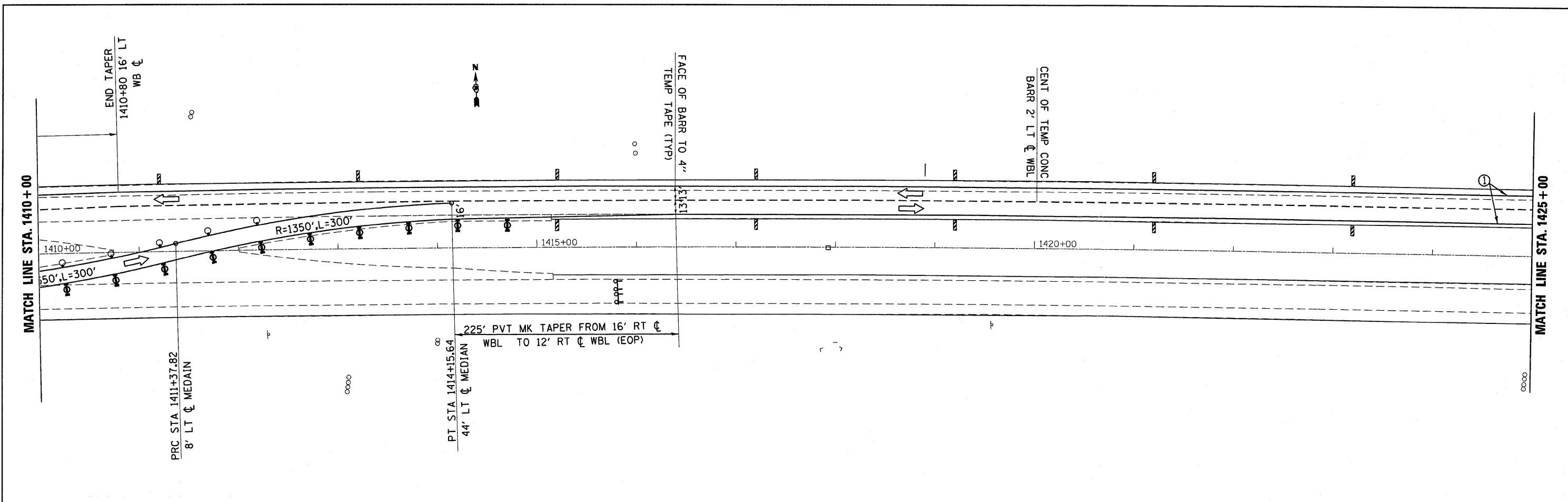

SYMBOLS

- ▨ Vertical Panel (back to back)
- ↑ Arrow board
- ⊥ Sign
- ↕ Direction Indicator barricade with steady burn monodirectional light
- ⊙ Drum with steady burn monodirectional light
- ⊥ Type II barricade, drum, or vertical barricade with steady burn monodirectional light
- ① Wet temporary pavement marking tape - TY III shall be placed throughout the taper and along-side the work area. The edge lines shall be white and the line near the barrier shall be yellow.

FILE NAME =	USER NAME = braboygo	DESIGNED -	REVISED -
c:\pwork\p1001\BRABOYPC\d0112640\d365908-sht-staging.dgn		DRAWN -	REVISED -
		CHECKED -	REVISED -
		DATE -	REVISED -

**STATE OF ILLINOIS  
DEPARTMENT OF TRANSPORTATION**

**STAGE II CONSTRUCTION**

SCALE: SHEET NO. OF SHEETS STA. TO STA.

F.A. RTE.	SECTION	COUNTY	TOTAL SHEETS	SHEET NO.
I-80	**	BUREAU	344	77
CONTRACT NO. 66908				
ILLINOIS FED. AID PROJECT				

\*\*06-[7BR&BR-1,7VB-M,6BR&6,7 RS-1 & 1]

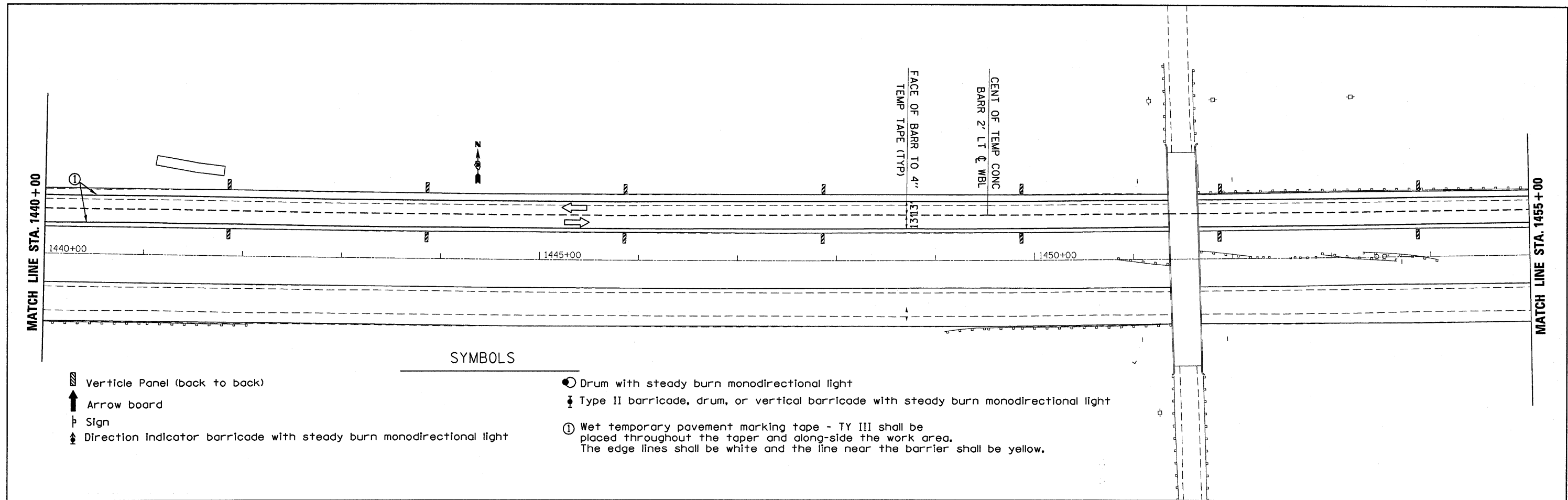

**SYMBOLS**

- ▨ Vertical Panel (back to back)
- ↑ Arrow board
- ⊥ Sign
- ⬇ Direction Indicator barricade with steady burn monodirectional light
- ⊙ Drum with steady burn monodirectional light
- ⬇ Type II barricade, drum, or vertical barricade with steady burn monodirectional light
- ① Wet temporary pavement marking tape - TY III shall be placed throughout the taper and along-side the work area. The edge lines shall be white and the line near the barrier shall be yellow.

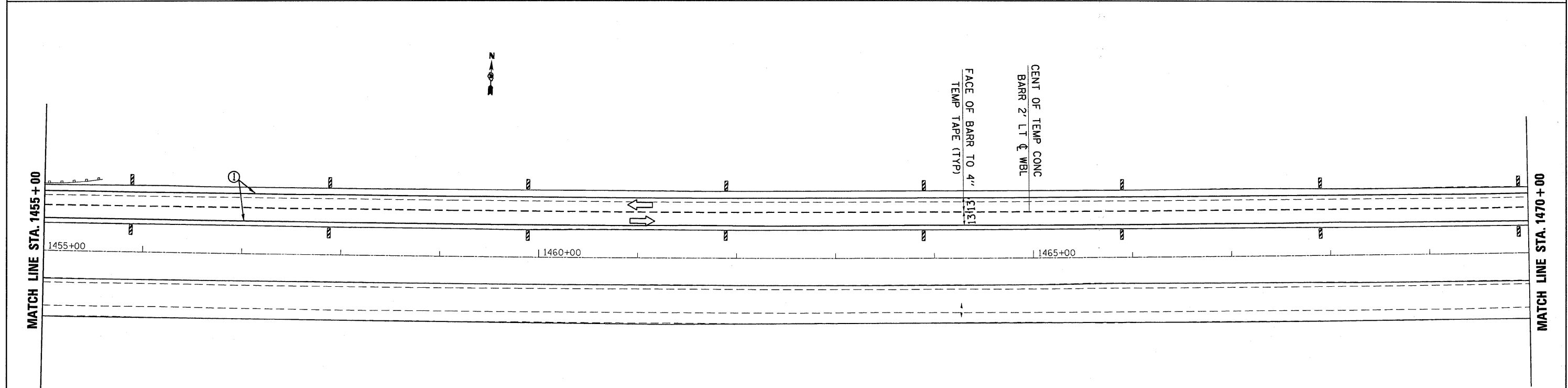

\*\*06-(7BR&BR-1,7VB-M,6BR&6,7 RS-1 & I)

FILE NAME =	USER NAME = braboypc	DESIGNED -	REVISED -
c:\pw_work\VPWIDOT\BRABOYPC\d0112640\d365908-ah1-staging.dgn		DRAWN -	REVISED -
PLOT SCALE = 50.0000 "/td> <td></td> <td>CHECKED -</td> <td>REVISED -</td>		CHECKED -	REVISED -
PLOT DATE = Sep 07, 2009 - 01:07:01 PM		DATE -	REVISED -

**STATE OF ILLINOIS  
DEPARTMENT OF TRANSPORTATION**

**STAGE II CONSTRUCTION**

SCALE: SHEET NO. OF SHEETS STA. TO STA.

F.A. RTE.	SECTION	COUNTY	TOTAL SHEETS	SHEET NO.
I-80	**	BUREAU	344	78
CONTRACT NO. 68908			ILLINOIS FED. AID PROJECT	

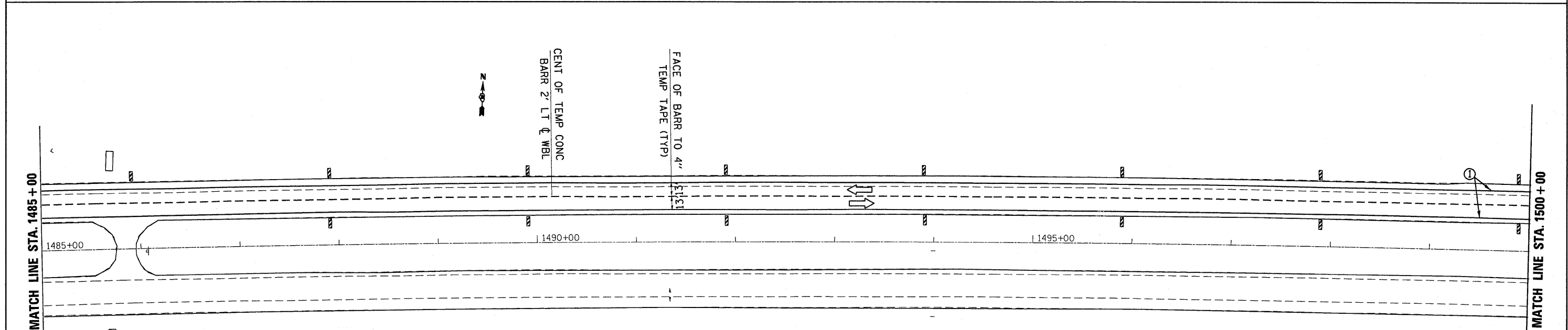
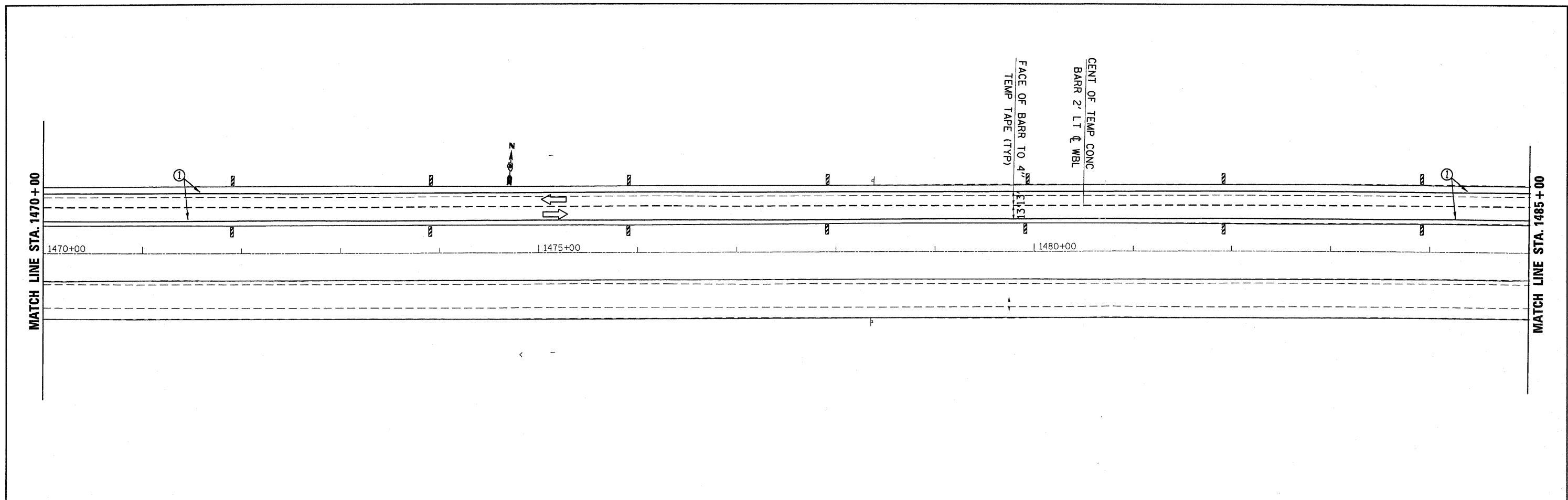

**SYMBOLS**

- ▨ Vertical Panel (back to back)
- ↑ Arrow board
- ⊥ Sign
- ↕ Direction Indicator barricade with steady burn monodirectional light
- ⊙ Drum with steady burn monodirectional light
- ⊥ Type II barricade, drum, or vertical barricade with steady burn monodirectional light
- ① Wet temporary pavement marking tape - TY III shall be placed throughout the taper and along-side the work area. The edge lines shall be white and the line near the barrier shall be yellow.

**\*\*06-[7BR&BR-1,7VB-M,6BR&6,7 RS-1 & I]**

FILE NAME = c:\pwwork\pwwid01\BRABOYPC\d0112640\d365928-sht-staging.dgn	USER NAME = brebaypc	DESIGNED -	REVISED -	<b>STATE OF ILLINOIS DEPARTMENT OF TRANSPORTATION</b>	<b>STAGE II CONSTRUCTION</b>			F.A. RTE.	SECTION	COUNTY	TOTAL SHEETS	SHEET NO.
	PLOT SCALE = 50.0000' / IN.	DRAWN -	REVISED -					I-80	**	BUREAU	344	79
PLOT DATE = Sep 07, 2009 - 01:06:48 PM	CHECKED -	REVISED -	SCALE:		SHEET NO.	OF	SHEETS	STA.	TO STA.	CONTRACT NO. 66908		
	DATE -	REVISED -	ILLINOIS FED. AID PROJECT									

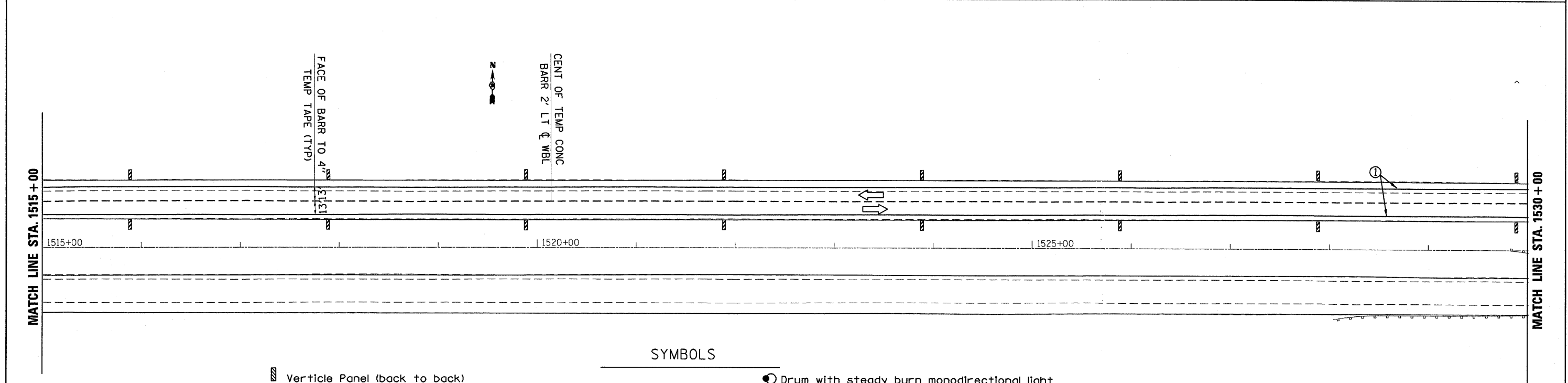
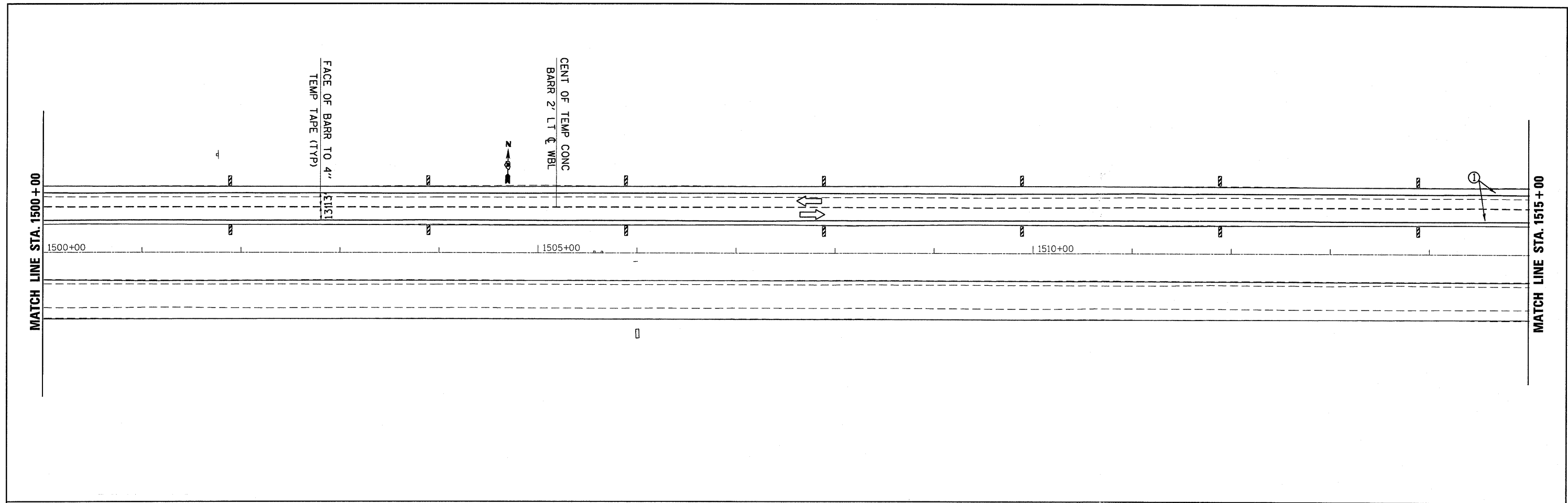

**SYMBOLS**

- Vertical Panel (back to back)
- Arrow board
- Sign
- Direction indicator barricade with steady burn monodirectional light
- Drum with steady burn monodirectional light
- Type II barricade, drum, or vertical barricade with steady burn monodirectional light
- Wet temporary pavement marking tape - TY III shall be placed throughout the taper and along-side the work area. The edge lines shall be white and the line near the barrier shall be yellow.

FILE NAME = ca:\pwwork\p\WIDOT\BRABOYPC\d0112640\d369308-ah1-staging.dgn				USER NAME = braboypc	DESIGNED - DRAWN - CHECKED - DATE -	REVISED - REVISED - REVISED - REVISED -	<b>STATE OF ILLINOIS DEPARTMENT OF TRANSPORTATION</b>	<b>STAGE II CONSTRUCTION</b>	F.A. RTE. I-80	SECTION **	COUNTY BUREAU	TOTAL SHEETS 344	SHEET NO. 80
PLOT SCALE = 50,0000 ' / IN.				PLOT DATE = Sep 07, 2009 - 01:06:39 PM				SCALE:	SHEET NO. OF SHEETS STA. TO STA.	CONTRACT NO. 66908			
**06-[7BR&BR-1,7VB-M,6BR&6,7 RS-1 & I]													ILLINOIS FED. AID PROJECT



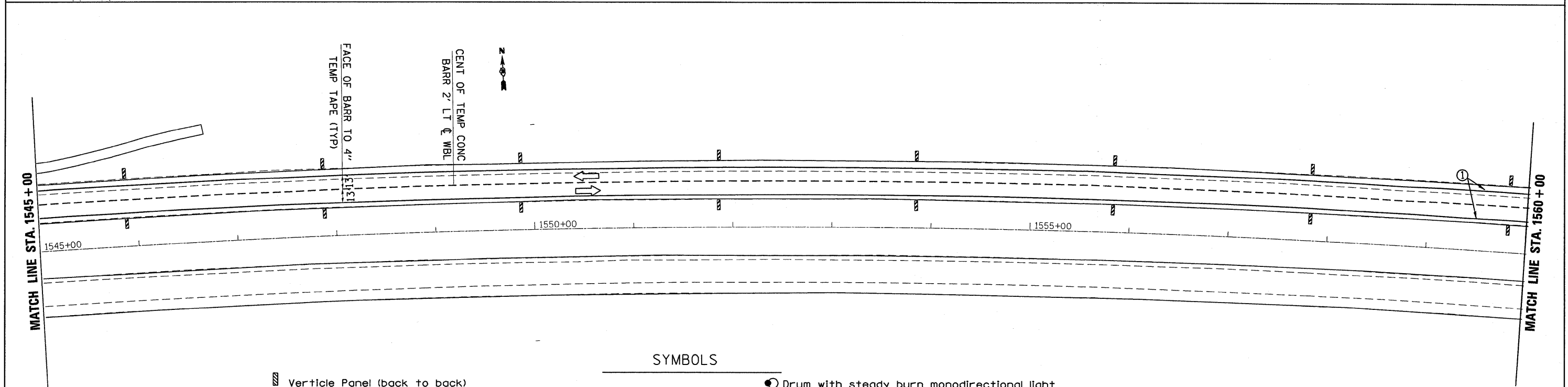
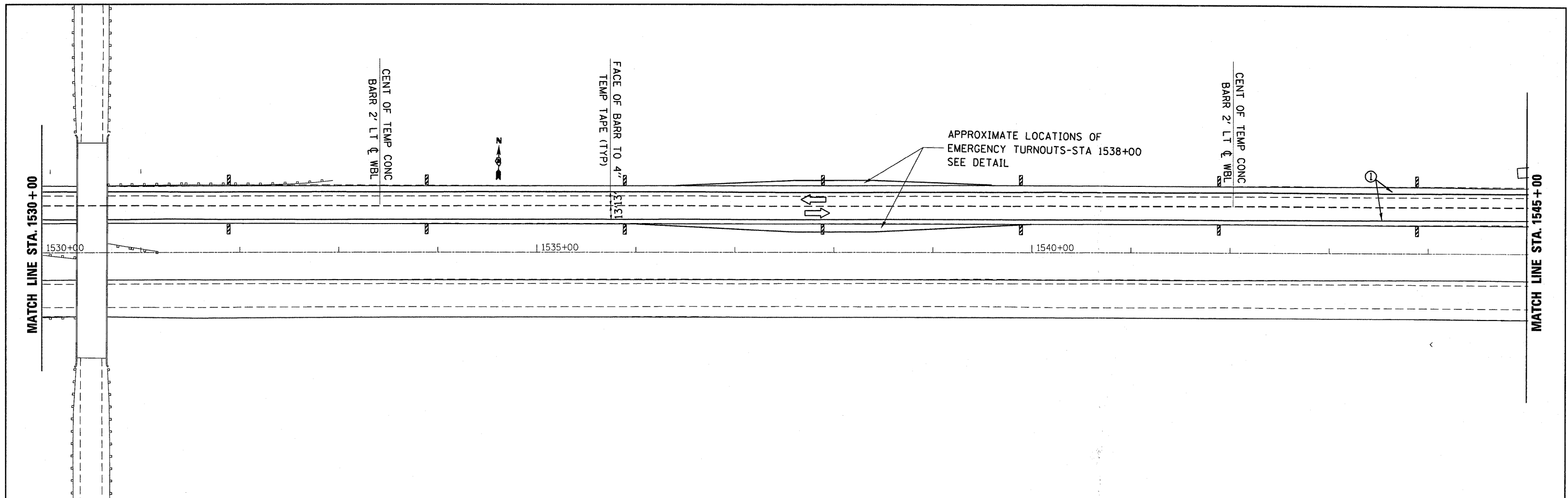

**SYMBOLS**

- ▨ Vertical Panel (back to back)
- ↑ Arrow board
- ⊥ Sign
- ↕ Direction indicator barricade with steady burn monodirectional light
- Drum with steady burn monodirectional light
- ⊥ Type II barricade, drum, or vertical barricade with steady burn monodirectional light
- ① Wet temporary pavement marking tape - TY III shall be placed throughout the taper and along-side the work area. The edge lines shall be white and the line near the barrier shall be yellow.

FILE NAME =	USER NAME = braboypc	DESIGNED -	REVISED -
es:\pw\work\PWID01\BRABOYPC\d8112640\d365908-sht-staging.dgn		DRAWN -	REVISED -
		CHECKED -	REVISED -
		DATE -	REVISED -

**STATE OF ILLINOIS  
DEPARTMENT OF TRANSPORTATION**

**STAGE II CONSTRUCTION**

SCALE: SHEET NO. OF SHEETS STA. TO STA.

**06-[7BR&BR-1,7VB-M,6BR&6,7 RS-1 & I]				
F.A. RTE.	SECTION	COUNTY	TOTAL SHEETS	SHEET NO.
I-80	**	BUREAU	344	81
			CONTRACT NO. 66908	
ILLINOIS FED. AID PROJECT				

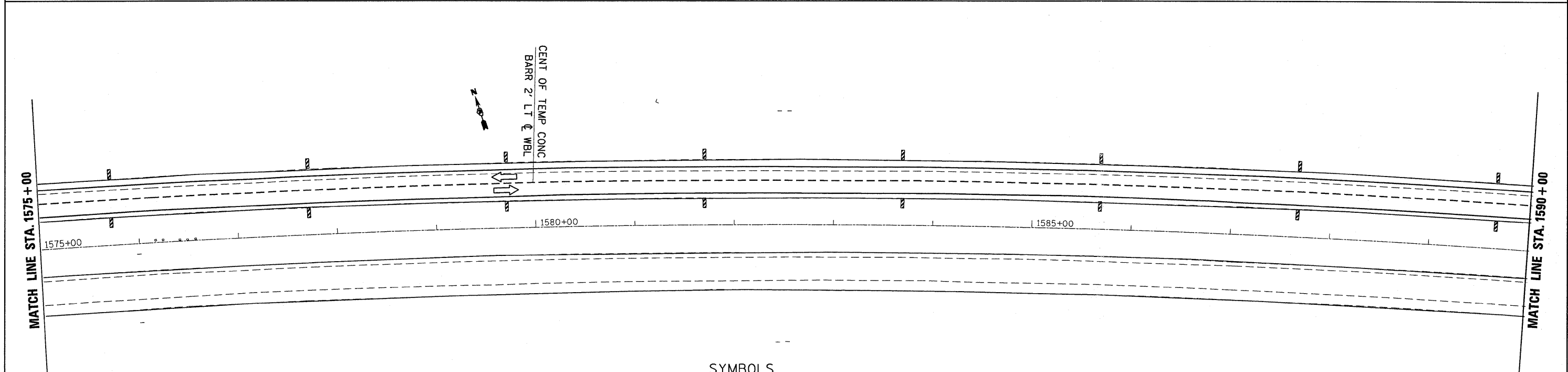
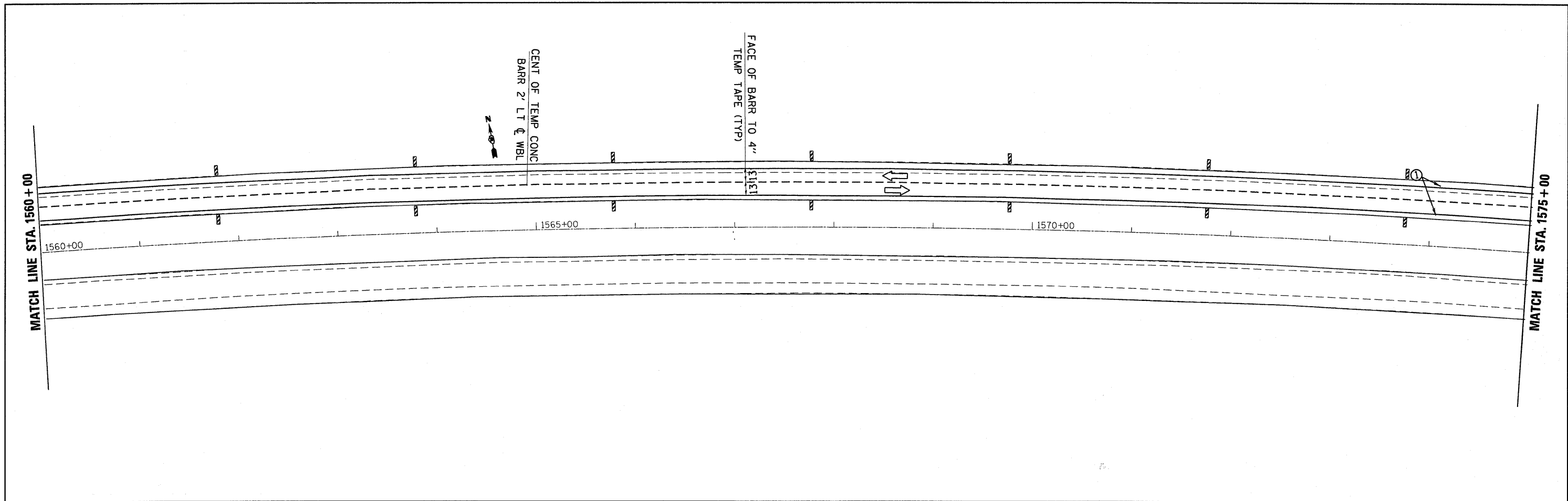

**SYMBOLS**

- ▨ Vertical Panel (back to back)
- ↑ Arrow board
- ⊥ Sign
- ↕ Direction Indicator barricade with steady burn monodirectional light
- ⊙ Drum with steady burn monodirectional light
- ⊥ Type II barricade, drum, or vertical barricade with steady burn monodirectional light
- ① Wet temporary pavement marking tape - TY III shall be placed throughout the taper and along-side the work area. The edge lines shall be white and the line near the barrier shall be yellow.

FILE NAME =	USER NAME = braboypc	DESIGNED -	REVISED -
o:\pwork\p\100T\BRABOYPC\d0112640\d365908-shr-staging.dgn		DRAWN -	REVISED -
		CHECKED -	REVISED -
		DATE -	REVISED -

**STATE OF ILLINOIS  
DEPARTMENT OF TRANSPORTATION**

**STAGE II CONSTRUCTION**

SCALE:      SHEET NO.    OF    SHEETS    STA.      TO STA.

**\*\*06-[7BR&BR-1,7VB-M,6BR&6,7 RS-1 & I]**

F.A. RTE.	SECTION	COUNTY	TOTAL SHEETS	SHEET NO.
I-80	**	BUREAU	344	82
CONTRACT NO. 66908				
ILLINOIS FED. AID PROJECT				

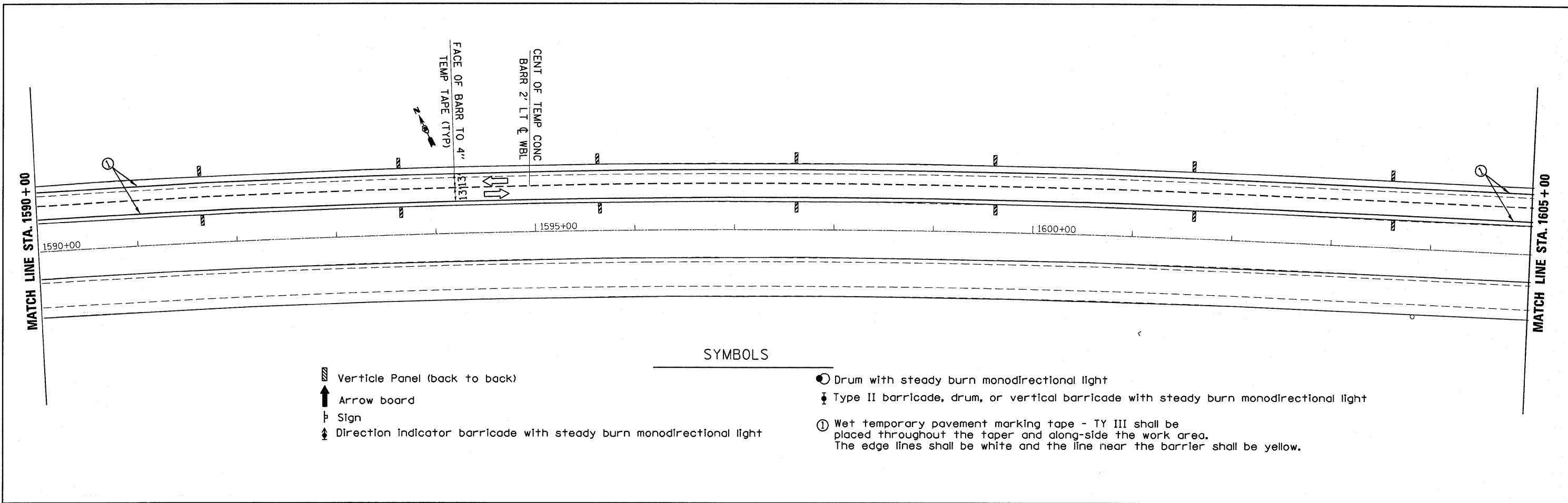

SYMBOLS

- Vertical Panel (back to back)
- Arrow board
- Sign
- Direction indicator barricade with steady burn monodirectional light
- Drum with steady burn monodirectional light
- Type II barricade, drum, or vertical barricade with steady burn monodirectional light
- Wet temporary pavement marking tape - TY III shall be placed throughout the taper and along-side the work area. The edge lines shall be white and the line near the barrier shall be yellow.

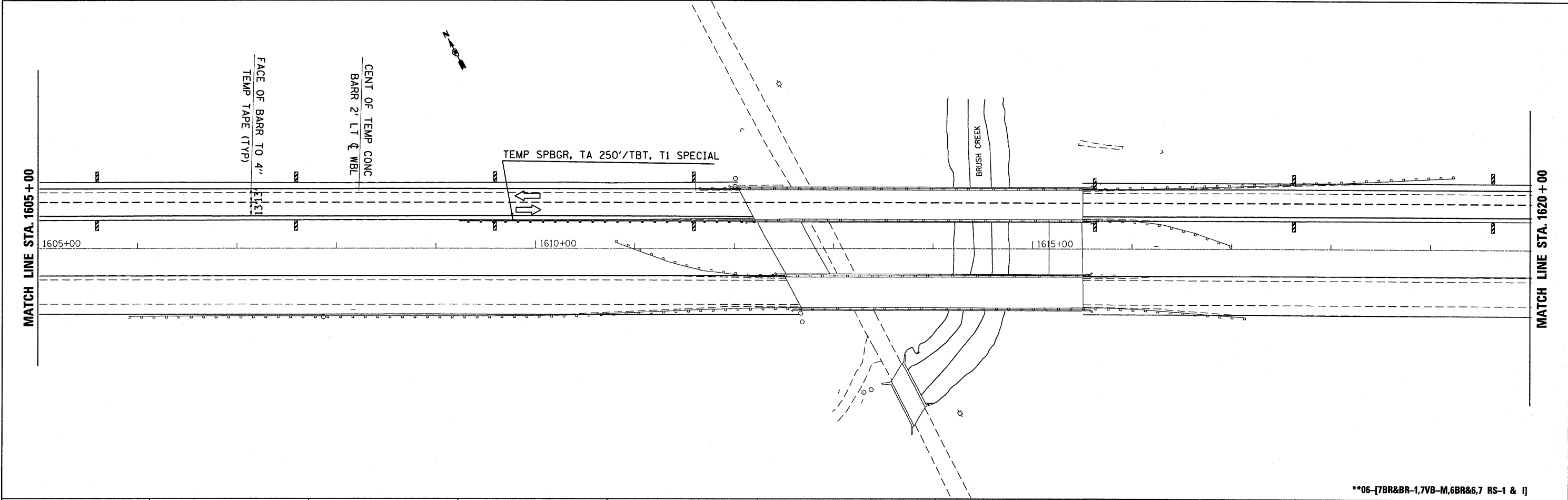

FILE NAME =	USER NAME = braboypc	DESIGNED -	REVISED -
c:\pwork\PWIDOT\BRABOYPC\d0112640\385908-shr-staging.dgn		DRAWN -	REVISED -
	PLOT SCALE = 50.0000' / IN.	CHECKED -	REVISED -
	PLOT DATE = Sep 07, 2009 - 01:17:24 PM	DATE -	REVISED -

**STATE OF ILLINOIS  
DEPARTMENT OF TRANSPORTATION**





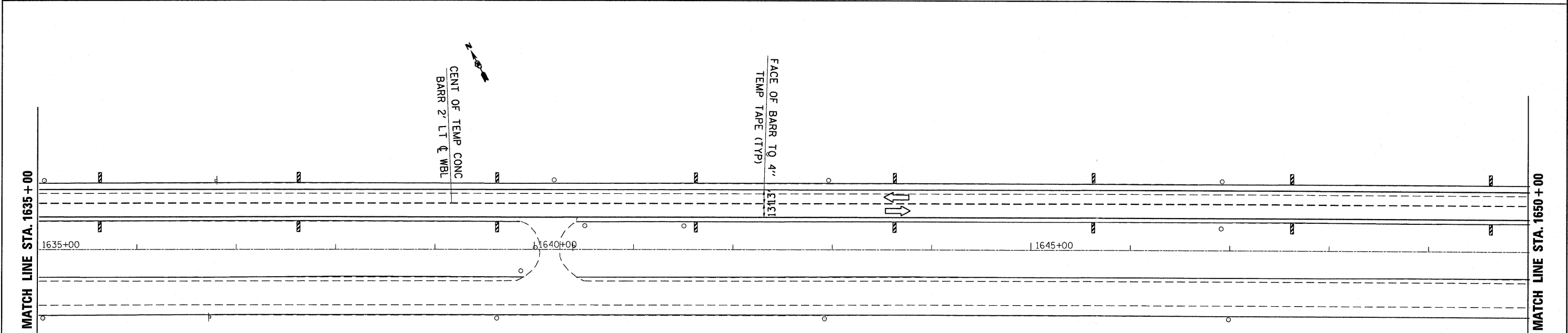
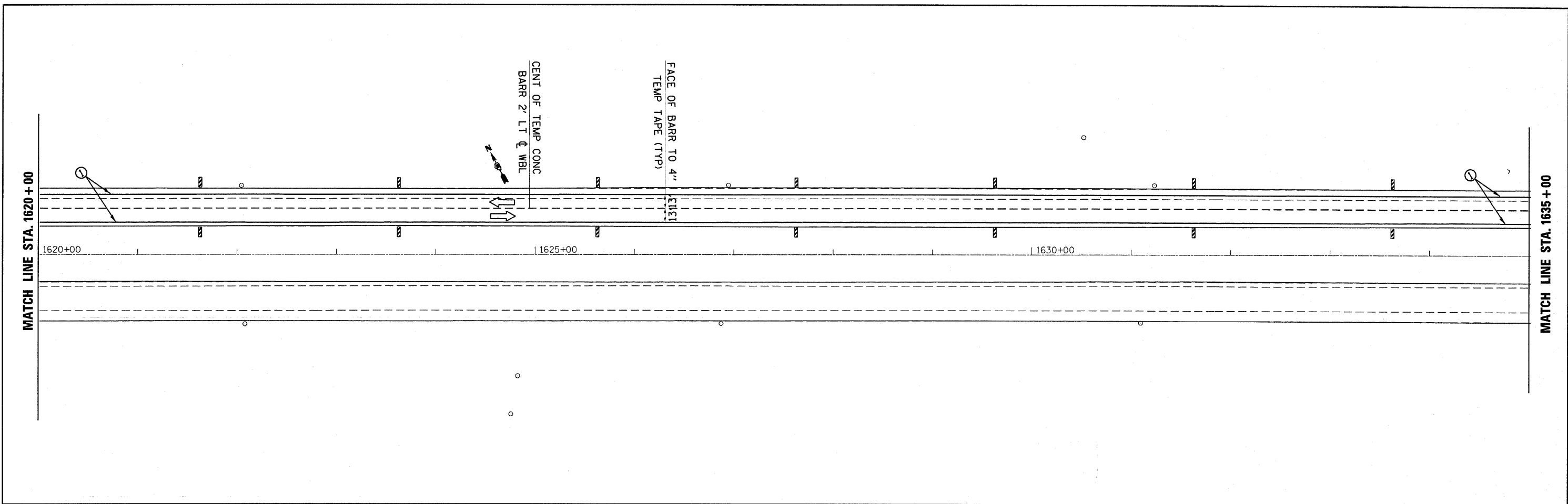

SCALE:	SHEET NO.	OF	SHEETS	STA.	TO STA.
--------	-----------	----	--------	------	---------

\*\*06-[7BR&BR-1,7VB-M,6BR&6,7 RS-1 & I]

F.A. RTE.	SECTION	COUNTY	TOTAL SHEETS	SHEET NO.
I-80	**	BUREAU	344	83
CONTRACT NO. 66908				
ILLINOIS FED. AID PROJECT				



SYMBOLS

-  Vertical Panel (back to back)
-  Arrow board
-  Sign
-  Direction indicator barricade with steady burn monodirectional light
-  Drum with steady burn monodirectional light
-  Type II barricade, drum, or vertical barricade with steady burn monodirectional light
-  Wet temporary pavement marking tape - TY III shall be placed throughout the taper and along-side the work area. The edge lines shall be white and the line near the barrier shall be yellow.

FILE NAME =	USER NAME = braboygo	DESIGNED -	REVISED -
c:\pwork\PIWIDOT\BRABOYPC\d0112640\d365908-shd-staging.dgn		DRAWN -	REVISED -
	PLOT SCALE = 50.0000 / IN.	CHECKED -	REVISED -
	PLOT DATE = Sep 07, 2009 - 01:17:15 PM	DATE -	REVISED -

STATE OF ILLINOIS  
DEPARTMENT OF TRANSPORTATION

STAGE II CONSTRUCTION

SCALE: SHEET NO. OF SHEETS STA. TO STA.

F.A. RTE.	SECTION	COUNTY	TOTAL SHEETS	SHEET NO.
I-80	**	BUREAU	344	84
CONTRACT NO. 66908				
ILLINOIS FED. AID PROJECT				

\*\*06-[7BR&BR-1,7VB-M,6BR&6,7 RS-1 & I]

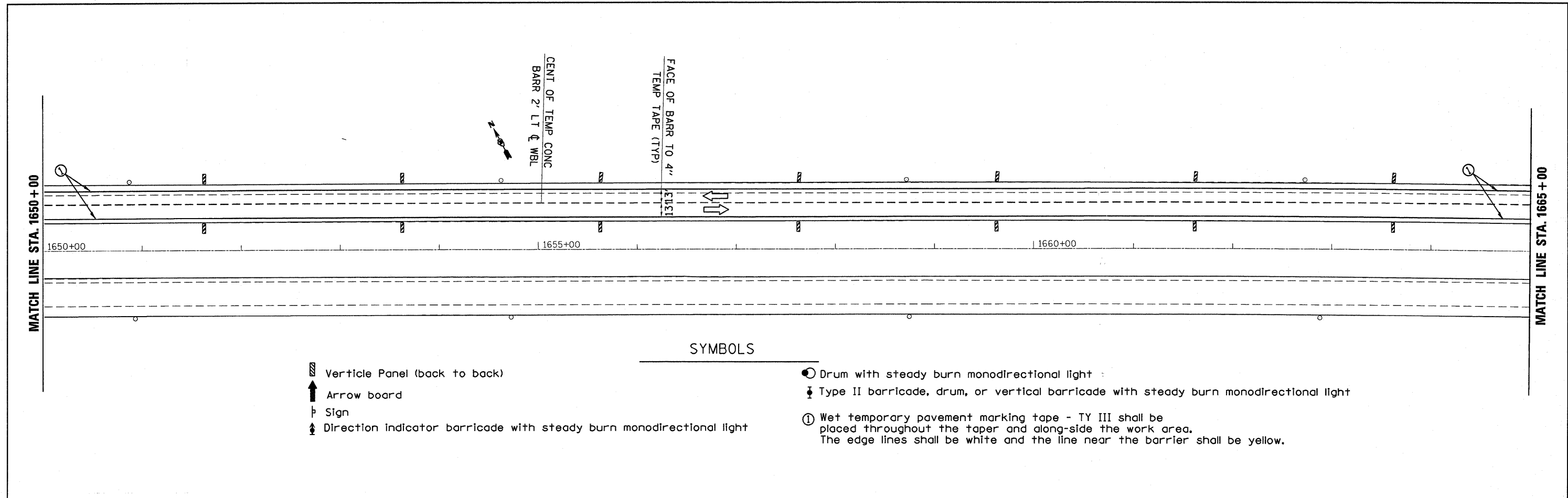

**SYMBOLS**

- ▨ Vertical Panel (back to back)
- ↑ Arrow board
- ⊥ Sign
- ⬇ Direction indicator barricade with steady burn monodirectional light
- ⊙ Drum with steady burn monodirectional light
- ⊥ Type II barricade, drum, or vertical barricade with steady burn monodirectional light
- ① Wet temporary pavement marking tape - TY III shall be placed throughout the taper and along-side the work area. The edge lines shall be white and the line near the barrier shall be yellow.

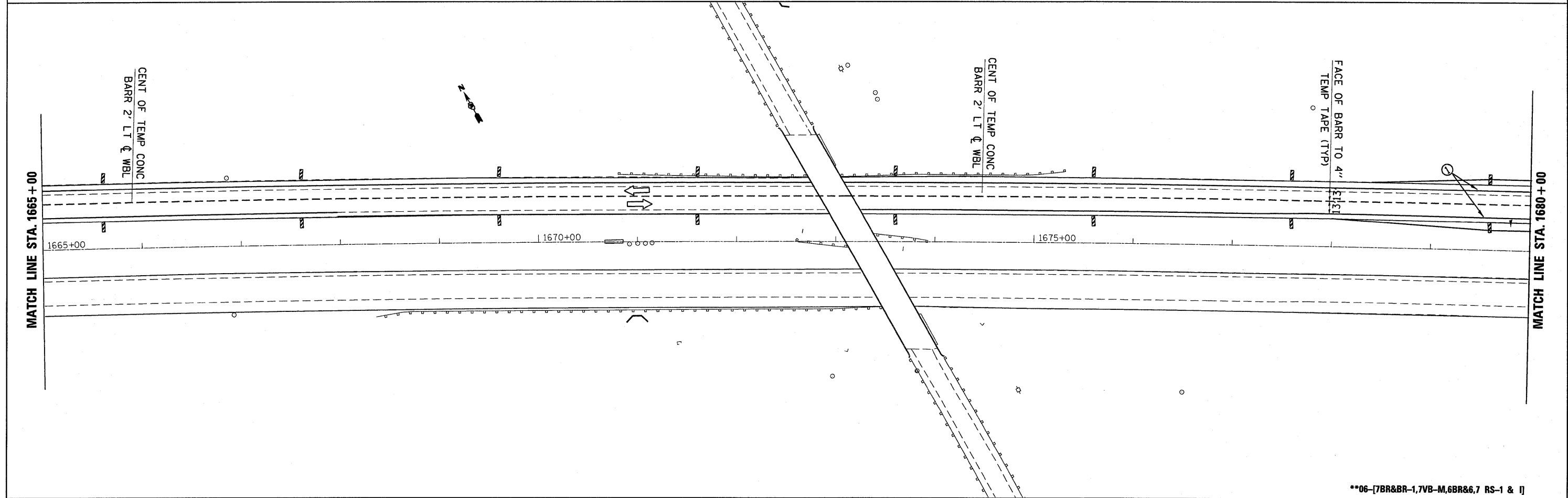

FILE NAME = c:\pwwork\pwwid\BRABOYPC\d0112640\d365908-sht-staging.dgn USER NAME = braboypc PLOT SCALE = 50.0000' / IN. PLOT DATE = Sep 07, 2009 - 01:17:07 PM				DESIGNED - DRAWN - CHECKED - DATE -				REVISED - REVISED - REVISED - REVISED -				STATE OF ILLINOIS DEPARTMENT OF TRANSPORTATION				STAGE II CONSTRUCTION				F.A. RTE. I-80		SECTION **		COUNTY BUREAU		TOTAL SHEETS 344		SHEET NO. 85		CONTRACT NO. 66908			
SCALE:				SHEET NO. OF SHEETS STA. TO STA.				ILLINOIS FED. AID PROJECT																									

\*\*06-[7BR&BR-1,7VB-M,6BR&6,7 RS-1 & I]

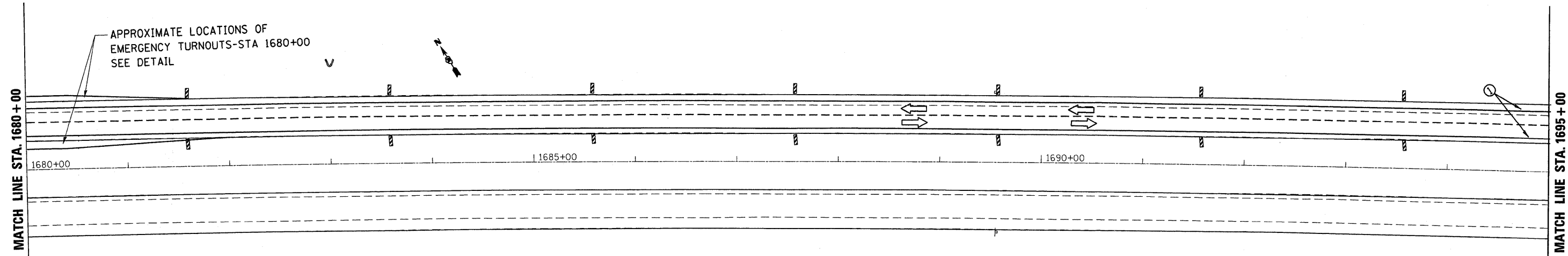

SYMBOLS

- Vertical Panel (back to back)
- Arrow board
- Sign
- Direction Indicator barricade with steady burn monodirectional light
- Drum with steady burn monodirectional light
- Type II barricade, drum, or vertical barricade with steady burn monodirectional light
- Wet temporary pavement marking tape - TY III shall be placed throughout the taper and along-side the work area. The edge lines shall be white and the line near the barrier shall be yellow.

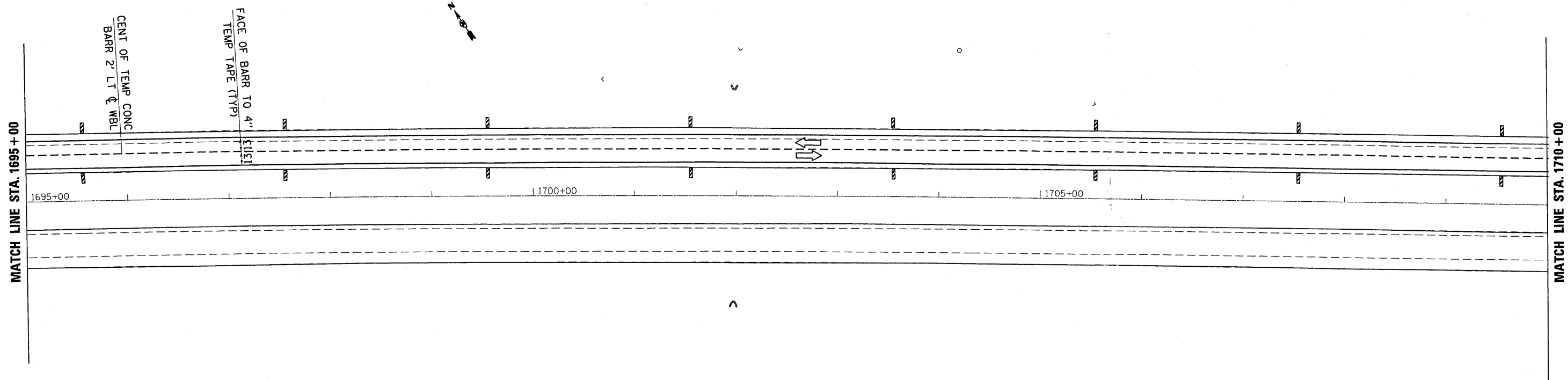

\*\*06-[7BR&BR-1,7VB-M,6BR&6,7 RS-1 & I]

FILE NAME = c:\pw_work\pwidot\BRABOYPC\d0112640\d365908-sht-staging.dgn	USER NAME = braboypc	DESIGNED -	REVISED -	<b>STATE OF ILLINOIS DEPARTMENT OF TRANSPORTATION</b>	<b>STAGE II CONSTRUCTION</b>			F.A. RTE.	SECTION	COUNTY	TOTAL SHEETS	SHEET NO.
	PLOT SCALE = 50.0000' / IN.	DRAWN -	REVISED -					I-80	**	BUREAU	344	86
PLOT DATE = Sep 07, 2009 - 01:05:39 PM	CHECKED -	REVISED -	REVISED -		SCALE:	SHEET NO.	OF	SHEETS	STA.	TO	STA.	CONTRACT NO. 66908
	DATE -	REVISED -	REVISED -		ILLINOIS FED. AID PROJECT							

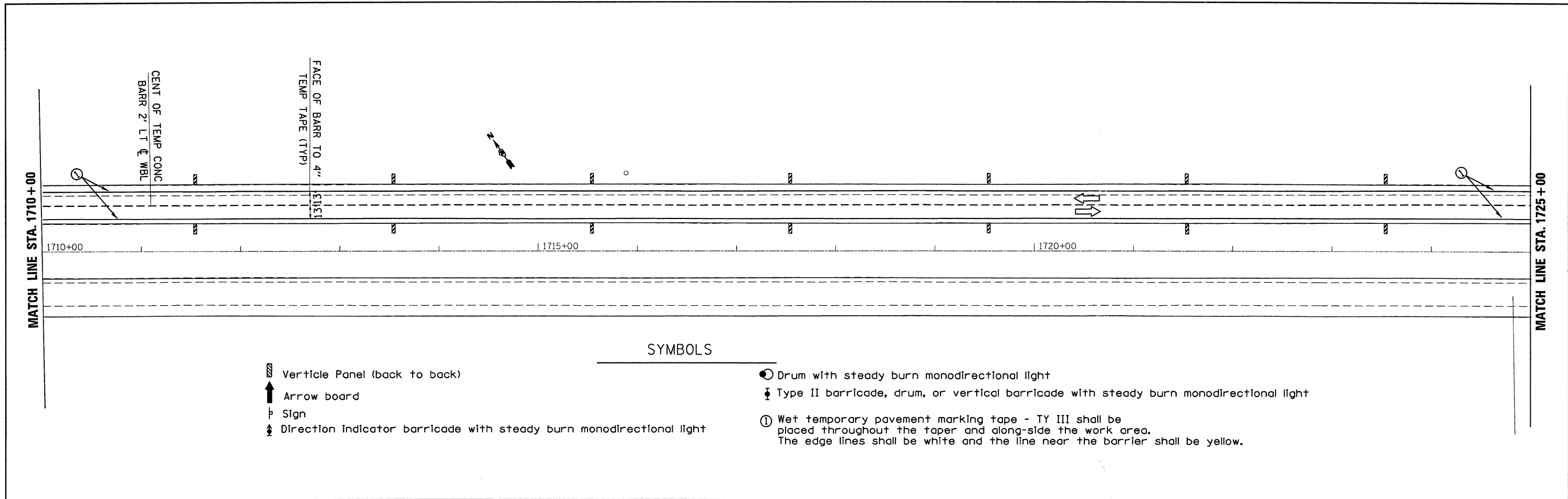

**SYMBOLS**

- Verticle Panel (back to back)
- Arrow board
- Sign
- Direction Indicator barricade with steady burn monodirectional light
- Drum with steady burn monodirectional light
- Type II barricade, drum, or vertical barricade with steady burn monodirectional light
- Wet temporary pavement marking tape - TY III shall be placed throughout the taper and along-side the work area. The edge lines shall be white and the line near the barrier shall be yellow.

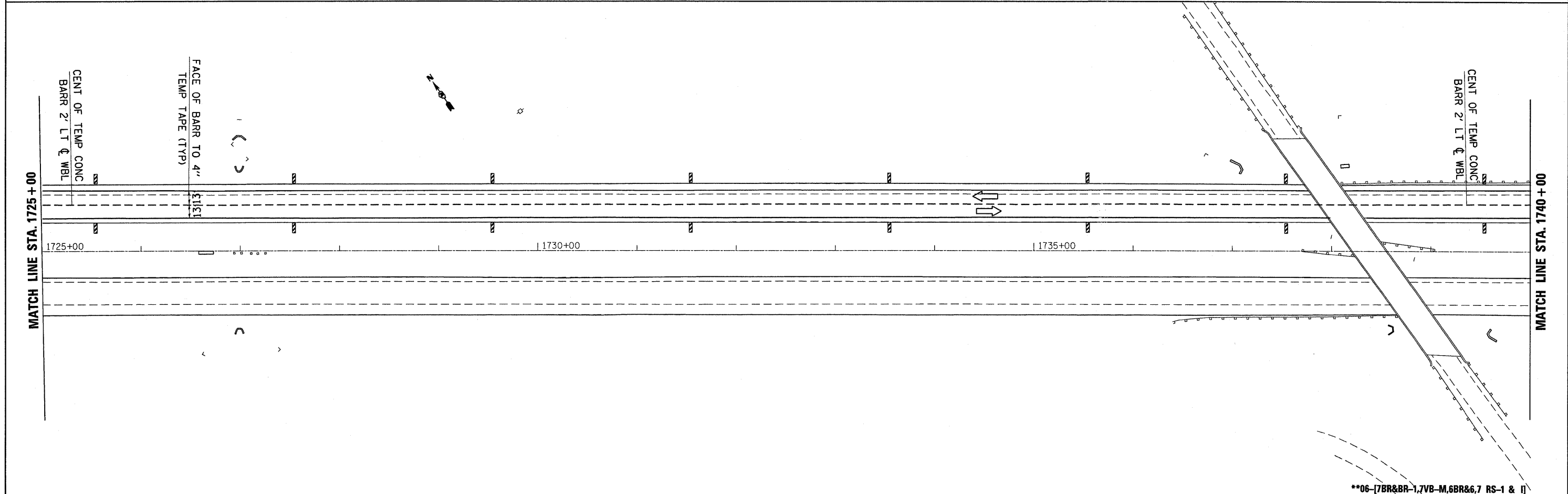

\*\*06-[7BR&BR-1,7VB-M,6BR&6,7 RS-1 & I]

FILE NAME =	USER NAME = braboygo	DESIGNED -	REVISED -	<b>STATE OF ILLINOIS DEPARTMENT OF TRANSPORTATION</b>	<b>STAGE II CONSTRUCTION</b>	F.A. RTE.	SECTION	COUNTY	TOTAL SHEETS	SHEET NO.	
ci\pwwork\pwwidot\BRABOYPC\d0112640\d365908-sht-staging.dgn		DRAWN -	REVISED -			I-80	**	BUREAU	344	87	
PLOT SCALE = 50.0000' / IN.		CHECKED -	REVISED -			CONTRACT NO. 66908					
PLOT DATE = Sep 07, 2009 - 01:05:29 PM		DATE -	REVISED -			ILLINOIS FED. AID PROJECT					
					SCALE:	SHEET NO. OF SHEETS		STA.	TO STA.		

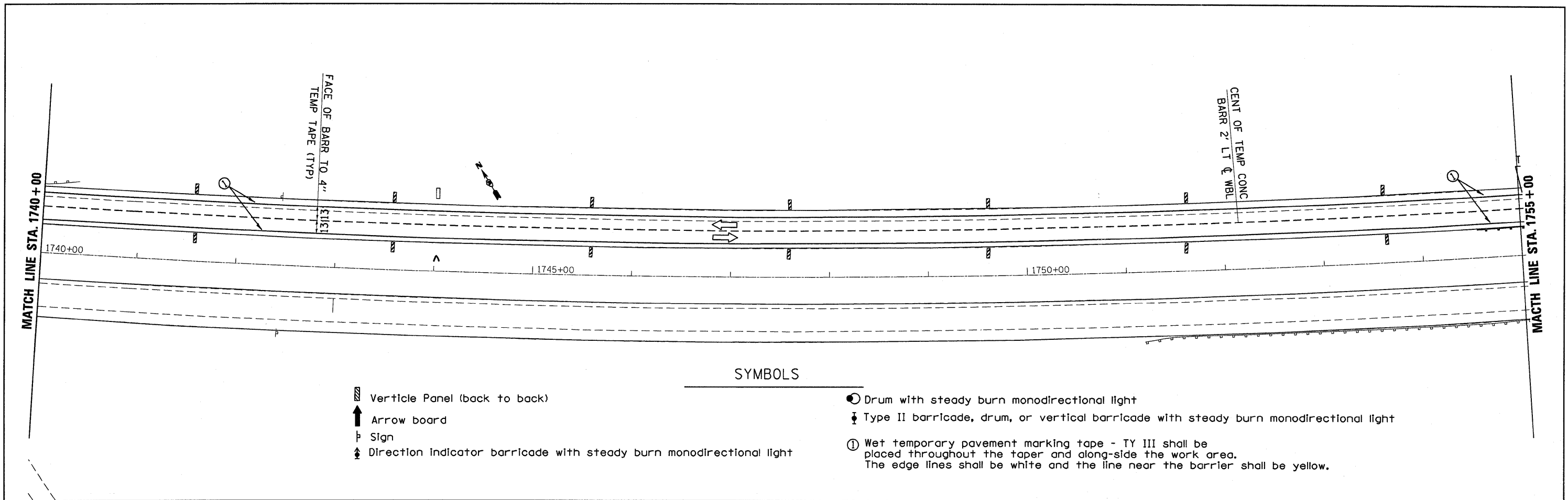

- SYMBOLS
- |  |   |
|--|---|
| <ul style="list-style-type: none"> <li> Vertical Panel (back to back)</li> <li> Arrow board</li> <li> Sign</li> <li> Direction Indicator barricade with steady burn monodirectional light</li> </ul> | <ul style="list-style-type: none"> <li> Drum with steady burn monodirectional light</li> <li> Type II barricade, drum, or vertical barricade with steady burn monodirectional light</li> <li> Wet temporary pavement marking tape - TY III shall be placed throughout the taper and along-side the work area. The edge lines shall be white and the line near the barrier shall be yellow.</li> </ul> |
|--|---|

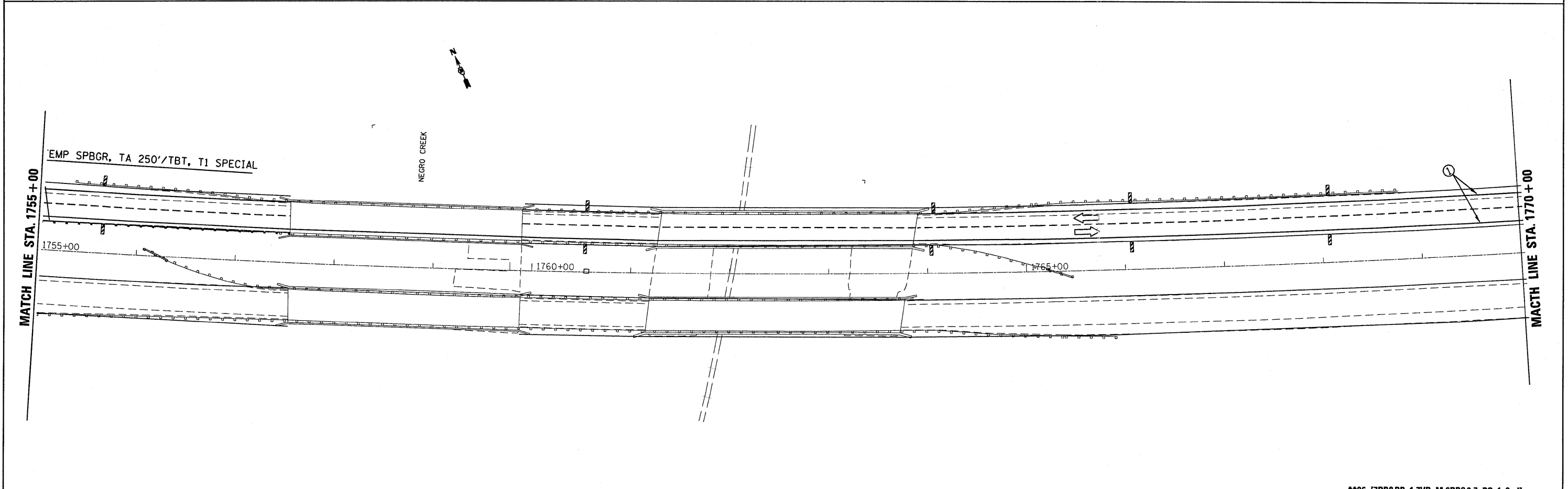

<b>STATE OF ILLINOIS DEPARTMENT OF TRANSPORTATION</b>				<b>STAGE II CONSTRUCTION</b>				<b>**06-[7BR&amp;BR-1,7VB-M,6BR&amp;6,7 RS-1 &amp; 1]</b>			
FILE NAME =	USER NAME = braboygo	DESIGNED -	REVISED -	SCALE:	SHEET NO. OF SHEETS	STA. TO STA.	F.A. RTE.	SECTION	COUNTY	TOTAL SHEETS	SHEET NO.
c:\pw_work\PWIDOT\BRABOYPC\d0112640\d365928-sh1-staging.dgn	928-sh1-staging.dgn	DRAWN -	REVISED -	I-80	**	BUREAU	344	88	ILLINOIS FED. AID PROJECT	CONTRACT NO. 66908	CONTRACT NO. 66908
PLOT SCALE = 50,0000' / IN.	CHECKED -	REVISED -	REVISED -								
PLOT DATE = Sep 07, 2009 - 01:05:17 PM	DATE -	REVISED -	REVISED -								



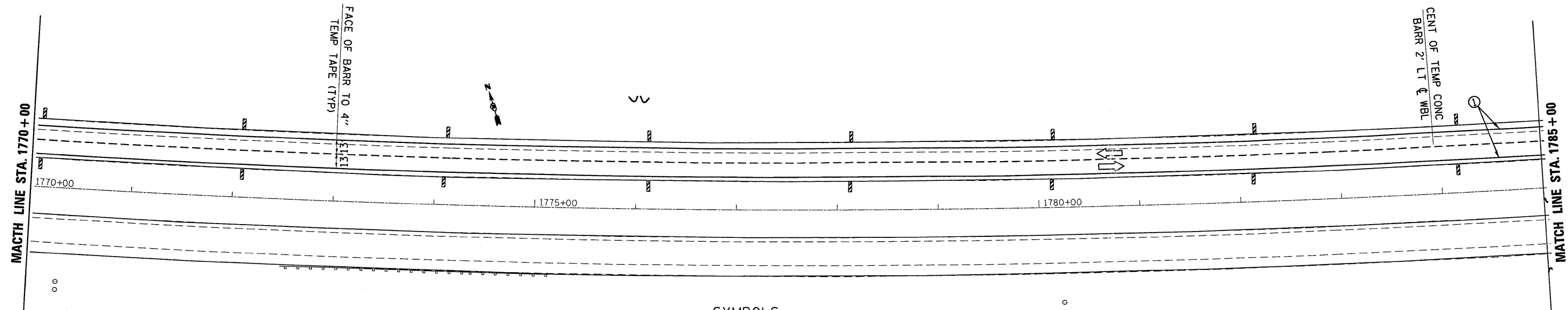

SYMBOLS

- Vertical Panel (back to back)
- Arrow board
- Sign
- Direction indicator barricade with steady burn monodirectional light
- Drum with steady burn monodirectional light
- Type II barricade, drum, or vertical barricade with steady burn monodirectional light
- Wet temporary pavement marking tape - TY III shall be placed throughout the taper and along-side the work area. The edge lines shall be white and the line near the barrier shall be yellow.

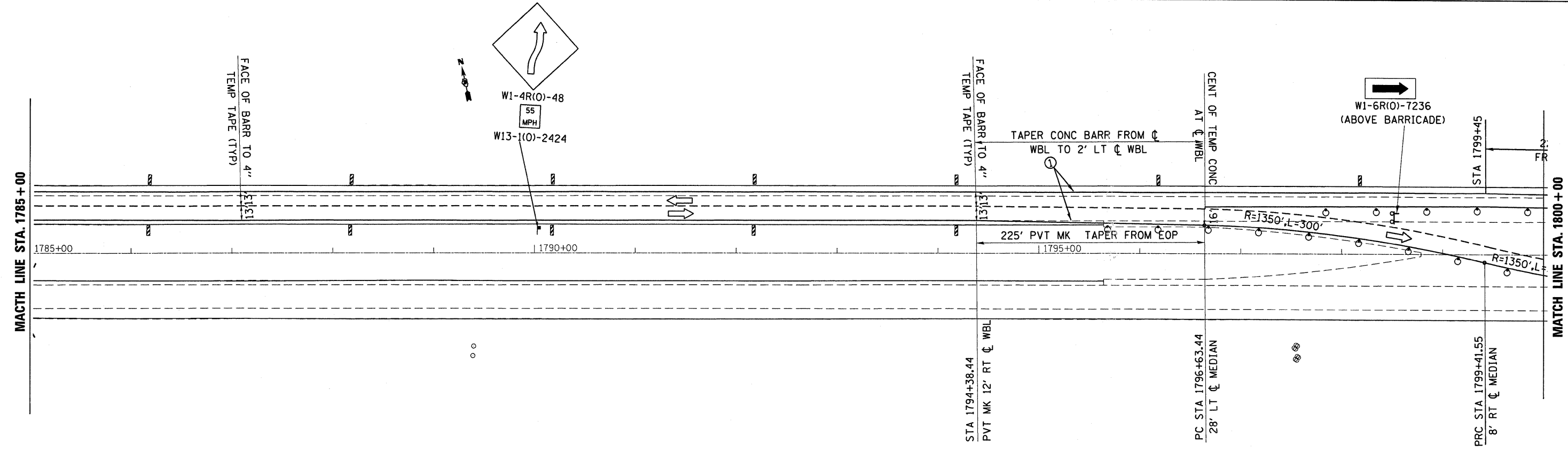

FILE NAME =	USER NAME = broboypc	DESIGNED -	REVISED -	<b>STATE OF ILLINOIS DEPARTMENT OF TRANSPORTATION</b>	<b>STAGE II CONSTRUCTION</b>			F.A. RTE.	SECTION	COUNTY	TOTAL SHEETS	SHEET NO.
ca\pw_work\PWIDOT\BRABOYPC\d0112648\d36	6908-shit-staging.dgn	DRAWN -	REVISED -					I-80	**	BUREAU	344	89
PLOT SCALE = 50.0000' / IN.	CHECKED -	REVISED -	REVISED -					CONTRACT NO. 66908				
PLOT DATE = Sep 07, 2009 - 01:05:09 PM	DATE -	REVISED -	REVISED -					ILLINOIS FED. AID PROJECT				
SCALE:					SHEET NO. OF SHEETS STA. TO STA.							

\*\*06-[7BR&BR-1,7VB-M,6BR&6,7 RS-1 & I]

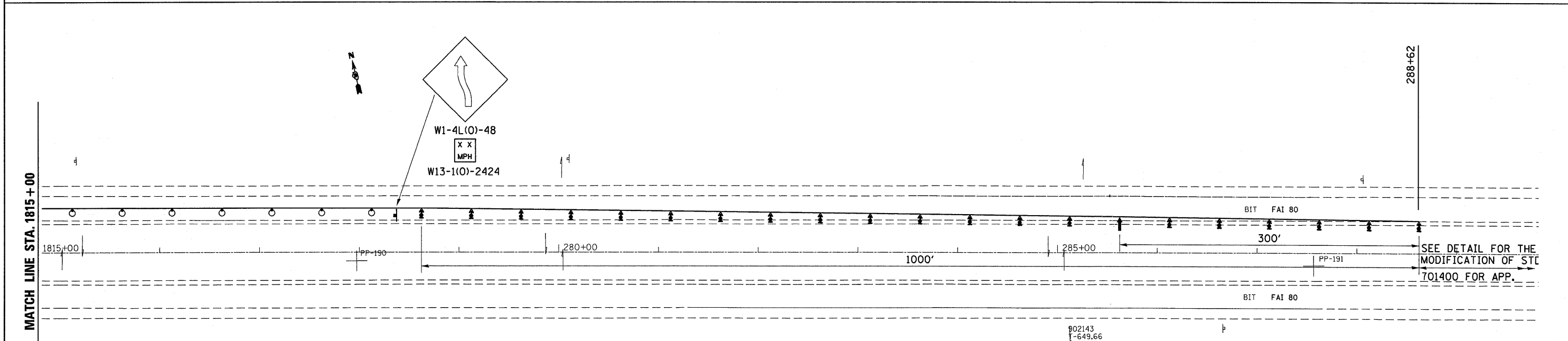
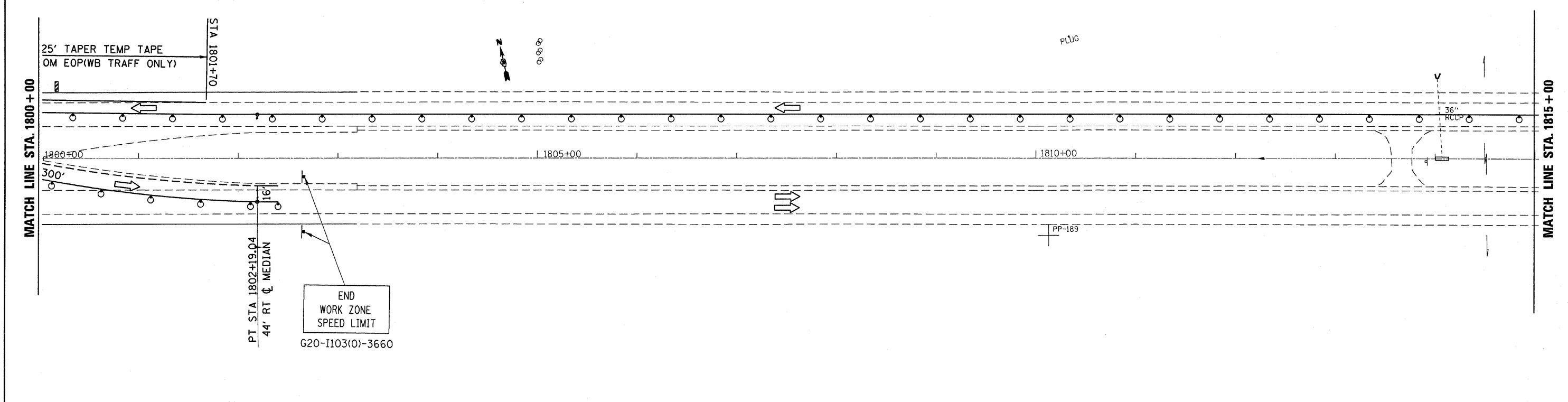

- SYMBOLS**
- Vertical Panel (back to back)
  - Arrow board
  - Sign
  - Direction indicator barricade with steady burn monodirectional light
  - Drum with steady burn monodirectional light
  - Type II barricade, drum, or vertical barricade with steady burn monodirectional light
  - Wet temporary pavement marking tape - TY III shall be placed throughout the taper and along-side the work area. The edge lines shall be white and the line near the barrier shall be yellow.

FILE NAME =	USER NAME = braboypc	DESIGNED -	REVISED -	<b>STATE OF ILLINOIS DEPARTMENT OF TRANSPORTATION</b>	<b>STAGE II CONSTRUCTION</b>			F.A. RTE. I-80	SECTION **	COUNTY	TOTAL SHEETS	SHEET NO.
c:\pw\work\PWIDOT\BRABOYPC\d0112640\d385908-shr-staging.dgn								SCALE: SHEET NO. OF SHEETS STA. TO STA.			ILLINOIS FED. AID PROJECT	
PLOT SCALE = 50.0000' / IN.												
PLOT DATE = Sep 07, 2009 - 01:05:00 PM												

\*\*06-[7BR&BR-1,7VB-M,6BR&6,7 RS-1 & I]

COUNTY	TOTAL SHEETS	SHEET NO.
BUREAU	344	90
CONTRACT NO. 66908		

NW 1/4, SEC. 17, T. 16 N., R. 11 E. 4TH P.M.

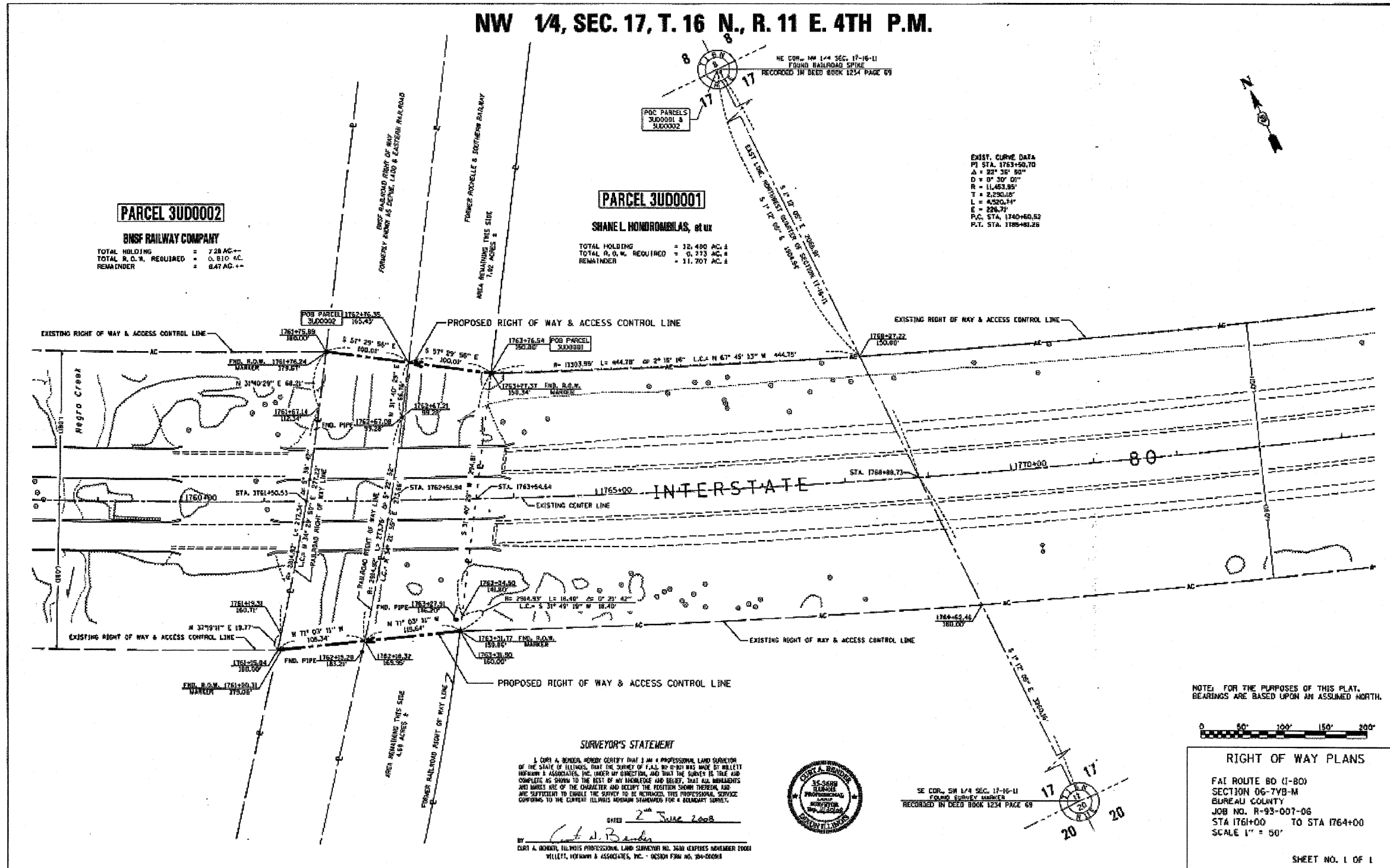

SURVEYOR'S STATEMENT

I, CLYDE A. BENDER, hereby certify that I am a Professional Land Surveyor of the State of Illinois, that the survey of F.A.S. 80 (I-80) WAS MADE BY WILLET WILHELM & ASSOCIATES, INC. UNDER MY DIRECTION, AND THAT THE SURVEY IS TRUE AND COMPLETE AS SHOWN TO THE BEST OF MY KNOWLEDGE AND BELIEF, THAT ALL MONUMENTS AND MARKERS ARE OF THE CHARACTER AND BEARING THE POSITION SHOWN THEREON, AND ARE SUFFICIENT TO ENABLE THE SURVEY TO BE REPRODUCED, THIS PROFESSIONAL SERVICE CONFORMING TO THE CURRENT ILLINOIS MEASUREMENT STANDARDS FOR A SURVEY SERVICE.

DATED 2<sup>nd</sup> June 2008

BY Clyde A. Bender

CLYDE A. BENDER, ILLINOIS PROFESSIONAL LAND SURVEYOR NO. 3630 EXPIRES NOVEMBER 2008  
WILLET, WILHELM & ASSOCIATES, INC. - DESIGN FIRM NO. 04-000018



NOTE: FOR THE PURPOSES OF THIS PLAT, BEARINGS ARE BASED UPON AN ASSUMED NORTH.



RIGHT OF WAY PLANS

F&I ROUTE 80 (I-80)  
SECTION 06-7VB-M  
BUREAU COUNTY  
JOB NO. R-93-007-06  
STA 1761+00 TO STA 1764+00  
SCALE 1" = 50'

SHEET NO. 1 OF 1

FILE NAME =	USER NAME = braboygo	DESIGNED -	REVISED -
ct:\pwwork\pwsdot\braboygo\d8112648\1368908-sht-details.DGN		DRAWN -	REVISED -
PLOT SCALE = 58.7363' / IN.		CHECKED -	REVISED -
PLOT DATE = Sep 07, 2009 - 01:49:31 PM		DATE -	REVISED -

STATE OF ILLINOIS  
DEPARTMENT OF TRANSPORTATION

ROW PLANS

SCALE: \_\_\_\_\_ SHEET NO. \_\_\_\_ OF \_\_\_\_ SHEETS | STA. \_\_\_\_\_ TO STA. \_\_\_\_\_

F&I RTE. 1-80	SECTION **	COUNTY BUREAU	TOTAL SHEETS 344	SHEET NO. 91
			CONTRACT NO. 66908	
[ILLINOIS] FED. AID PROJECT				

\*\*06-[7BR&BR-17VB-M,6BR&6,7 RS-1 & I]

ALL SIGNS SHALL BE FURNISHED, ERECTED, AND MAINTAINED BY THE CONTRACTOR AND SHALL BECOME THE PROPERTY OF THE CONTRACTOR AT THE COMPLETION OF THE PROJECT.

THE TWO EXTRA MESSAGE BOARDS ON I-80 AS OUTLINED IN THE SPECIAL PROVISIONS SHALL DISPLAY THE FOLLOWING MESSAGE:

I-80 CONSTRUCTION AHEAD  
EXPECT DELAYS  
ALT ROUTE AVAILABLE

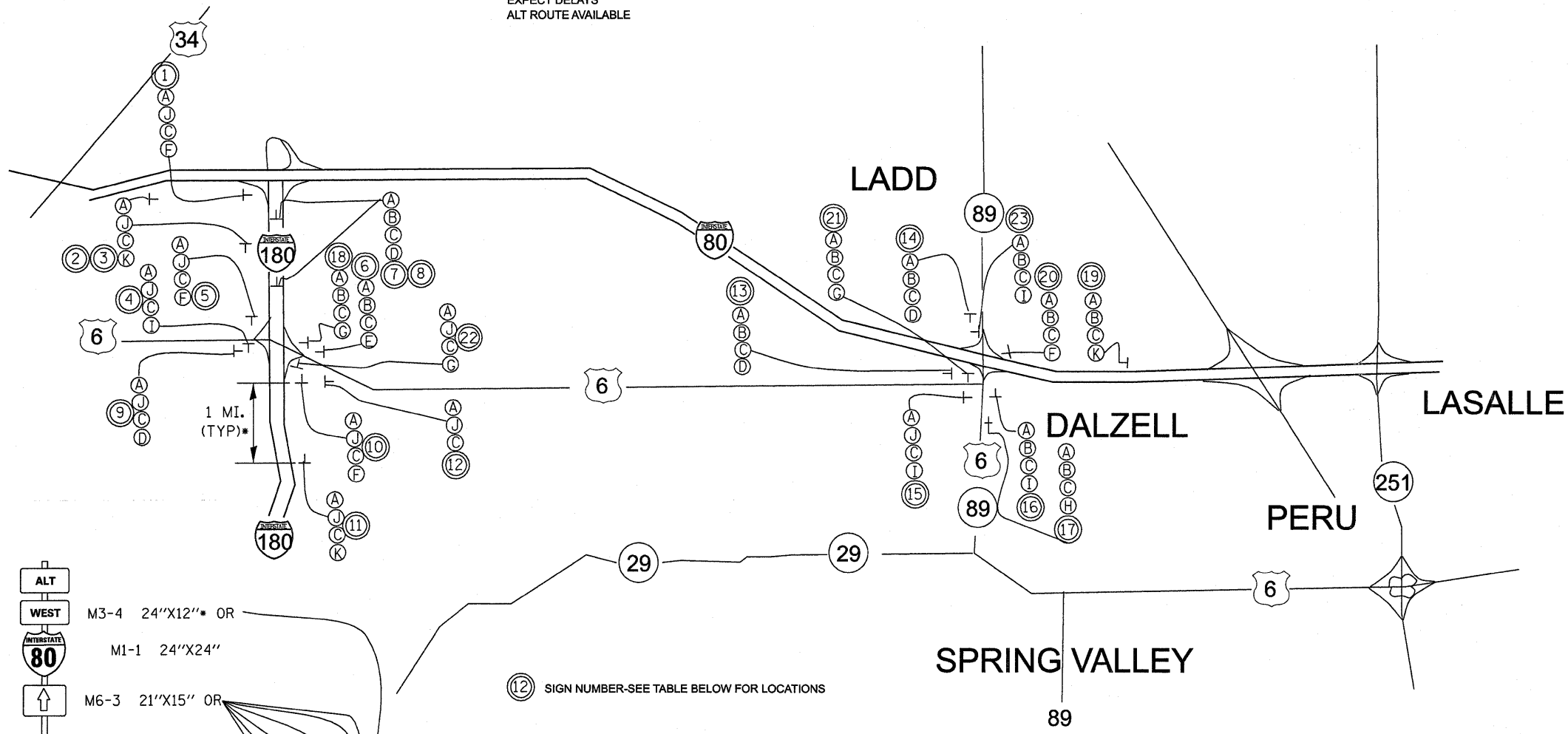

SIGN

- (A)
- (B)
- (C)
- (D)
- (E)
- (F)
- (G)
- (H)
- (I)
- (J)
- (K)

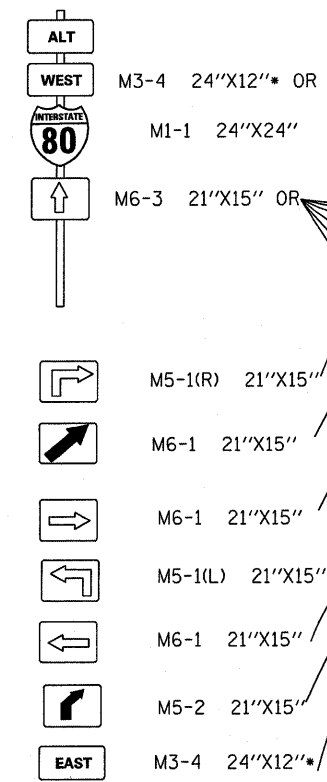

\*SIGNS A, D, E, F, G, H, I, K FLORESCENT ORANGE W/BLACK SYMBOLS  
\*SIGNS B AND J BLUE WITH WHITE LETTERS

(12) SIGN NUMBER-SEE TABLE BELOW FOR LOCATIONS

SIGN NUMBER	LOCATION OF SIGN	SIGNS TO BE USED	SIGN NUMBER	LOCATION OF SIGN	SIGNS TO BE USED
1	I-80(EB) AT START OF RAMP	A, J, C, F	12	US 6(EB), 500' EAST OF I-180	A, J, C, D
2	I-80 (EB) 1 MILE PRIOR TO SIGN 1	A, J, C, K	13	US 6(WB), 500' WEST OF IL 89	A, B, C, D
3	I-180(SB) 1 MILE PRIOR TO SIGN 5	A, J, C, K	14	IL 89 (SB) 100' BEFORE RAMPS	A, B, C, D
4	AT TOP OF RAMP FOR I-180(SB) TRAFFIC HEADING EAST ONTO US 6	A, J, C, I	15	US 6 (EB) AT US 6/IL 89 INTERSECTION	A, J, C, I
5	I-180 (SB) AT START OF RAMP	A, J, C, F	16	US 6/IL 89(NB) AT RADIUS RETURN	A, B, C, I
6	US 6(WB) 100' PRIOR TO RAMP	A, B, C, E	17	IL 89 (NB) 100' BEFORE US 6	A, B, C, H
7	I-180(NB) 1 MILE PRIOR TO SIGN 8, ON PASSING LANE SIDE	A, B, C, D	18	US 6 (WB) AT I-180 RAMP (NB)	A, B, C, G
8	I-180(NB) 0.5 MILE PRIOR INTERCHANGE, ON PASSING LANE SIDE	A, B, C, D	19	I-80(WB) 1 MILE EAST OF SIGN 20	A, B, C, K
9	US 6(EB) 100' PRIOR TO RAMP	A, J, C, D	20	I-80(WB) AT START OF RAMP TO 89	A, B, C, F
10	I-180(NB) AT START OF RAMP	A, J, C, F	21	IL 89 (SB) AT US 6/IL 89 INTERSECTION	A, J, C, G
11	I-180 (NB) 1 MILE PRIOR TO SIGN 10	A, J, C, K	22	I-180 (NB) AT THE END OF EXIT RAMP WITH US 6	A, J, C, G
			23	I-180 (WB) AT THE END OF RAMP WITH IL 89	A, B, C, G

FILE NAME =	USER NAME = braboygo	DESIGNED -	REVISD -
ct:\pw_work\pwork\braboygo\d0112640\d368	988-sht-details.DGN	DRAWN -	REVISD -
PLOT SCALE = 58.7353' / IN.	CHECKED -	REVISD -	REVISD -
PLOT DATE = Sep 07, 2009 - 01:49:24 PM	DATE -	REVISD -	REVISD -

STATE OF ILLINOIS  
DEPARTMENT OF TRANSPORTATION

ALTERNATE ROUTE SIGNING

SCALE: \_\_\_\_\_ SHEET NO. \_\_\_\_ OF \_\_\_\_ SHEETS STA. \_\_\_\_\_ TO STA. \_\_\_\_\_

F.A. RTE.	SECTION	COUNTY	TOTAL SHEETS	SHEET NO.
I-80	**	BUREAU	344	92
			CONTRACT NO. 66908	
[ILLINOIS] FED. AID PROJECT				

\*\*06-[7BR&BR-1,7VB-M,6BR&6.7 RS-1 & I

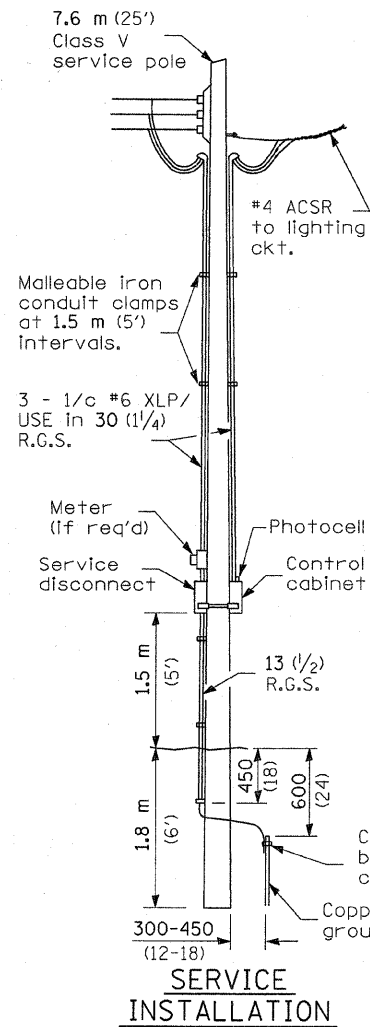

NOTE:  
 Min. Pole spacing 60 m (200')  
 Max. Pole spacing 75 m (250')

Setback shall be min. 9 m (30')  
 or 1.5 m (5') back of ditch, unless  
 breakaway type pole is used.  
 SEE SHEET 94 FOR TEMPORARY  
 LIGHTING PLAN

**SERVICE  
 INSTALLATION**

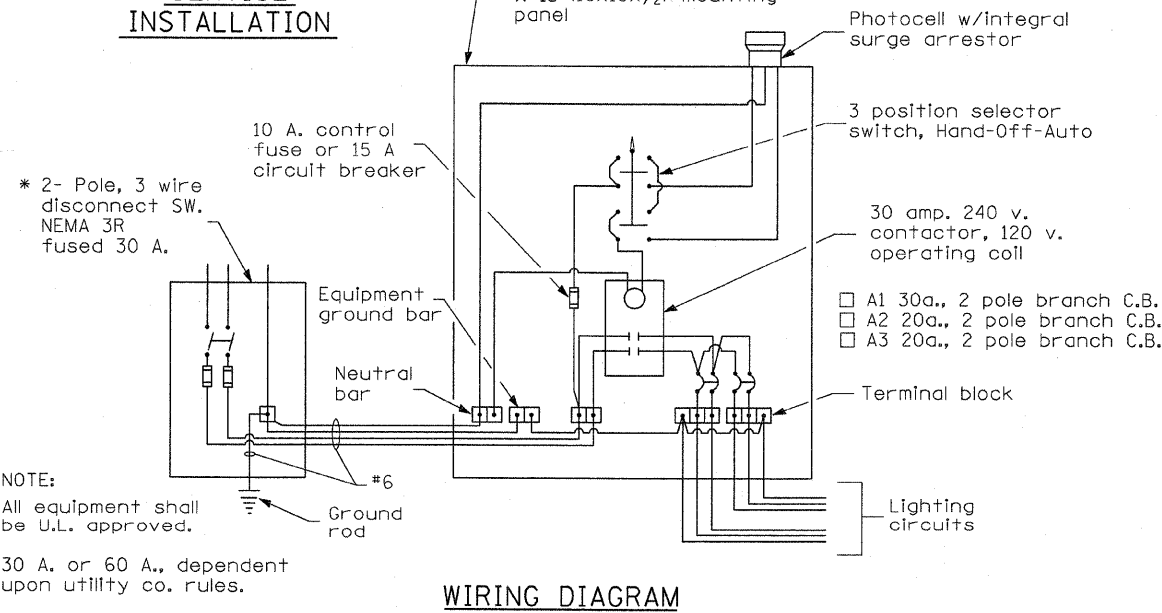

NOTE:  
 All equipment shall  
 be U.L. approved.  
 \* 30 A. or 60 A., dependent  
 upon utility co. rules.

**WIRING DIAGRAM**

- ① Luminaire, 250W HPS
- ② Wood pole, class 3 or better
- ③ 63 (2 1/2) Galv. steel conduit
- ④ Single offset pole band
- ⑤ Conduit bushing
- ⑥ Cable clamps on 600 (24) centers
- ⑦ 2/c #12 Type USE cable
- ⑧ 25 (1) Galv. steel conduit 3.0 m (10') in length

- ⑨ 16 (5/8) Ø hot dipped galvanized bolt with flat washer & locknut (3 req'd)
- ⑩ Conduit clamps on 900 (36) centers
- ⑪ Unit duct
- ⑫ Threaded reducer
- ⑬ "C" Condulet, threaded
- ⑭ 40 (1 1/2) Galv. steel conduit for 1 unit duct or 75 (3) galv. steel conduit for 2 or 3 unit ducts.

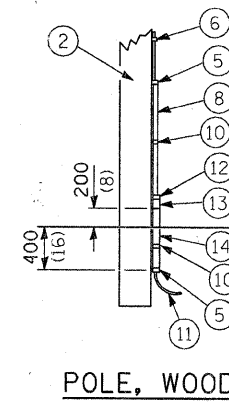
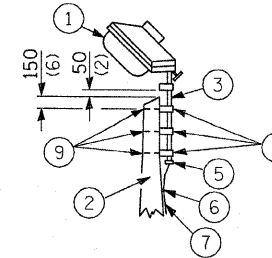

POLE LENGTH	DEPTH IN GROUND
19.8 m (65')	3.6 m (12')
18.0 m (60')	3.0 m (10')
16.8 m (55')	2.7 m (9')
16.0 m (50')	2.4 m (8')
13.7 m (45')	2.1 m (7')
12.0 m (40')	2.0 m (6.5')
10.7 m (35')	1.8 m (6')
9.0 m (30')	1.7 m (5.5')

All dimensions are in millimeters (inches) unless otherwise shown.

**TEMPORARY  
 ROADWAY LIGHTING**

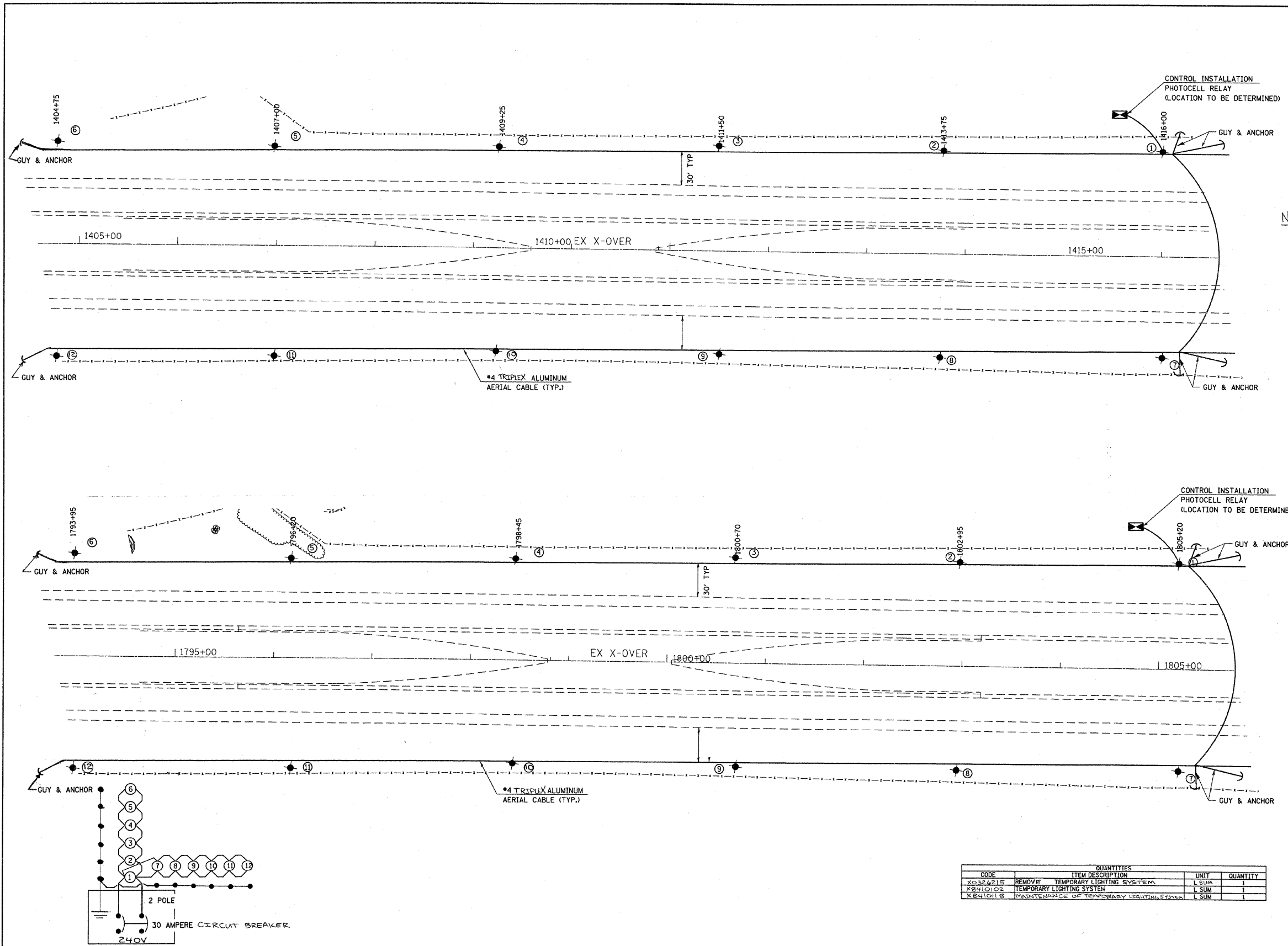

**NOTE:**  
 1. POLE HEIGHT SHALL BE INCREASED AS NECESSARY TO MAINTAIN THE MINIMUM REQUIRED CLEARANCE OF AERIAL CABLE OVER THE ROADWAY.

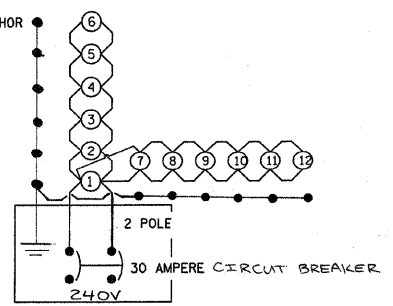

CONTROL INSTALLATION - PHOTOCELL RELAY  
 WIRING DIAGRAM

CODE	QUANTITIES	UNIT	QUANTITY
X0324215	REMOVE TEMPORARY LIGHTING SYSTEM	L SUM	1
X8410102	TEMPORARY LIGHTING SYSTEM	L SUM	1
X8410118	MAINTENANCE OF TEMPORARY LIGHTING SYSTEM	L SUM	1

FILE NAME =	USER NAME = braboypc	DESIGNED -	REVISED -
c:\pwork\pindot\braboypc\d8112648\vd368988-sht-details.dgn		DRAWN -	REVISED -
	PLOT SCALE = 50.7353' / IN.	CHECKED -	REVISED -
	PLOT DATE = Sep 07, 2009 - 01:49:09 PM	DATE -	REVISED -

**STATE OF ILLINOIS  
 DEPARTMENT OF TRANSPORTATION**

**LIGHTING DETAILS**

SCALE: \_\_\_\_\_ SHEET NO. \_\_\_\_ OF \_\_\_\_ SHEETS STA. \_\_\_\_\_ TO STA. \_\_\_\_\_

**\*\*06-[7BR&BR-1,7VB-M,6BR&6,7 RS-1 & 1**

F.A. RTE.	SECTION	COUNTY	TOTAL SHEETS	SHEET NO.
I-80	**	BUREAU	344	94
CONTRACT NO. 06908			ILLINOIS FED. AID PROJECT	

STATE OF ILLINOIS  
DEPARTMENT OF TRANSPORTATION

Bench Mark: BM #408 Permanent Survey Marker. Sta. 3422+41.05 Offset 139.15 Left, El. 692.91

Existing Structure: S.N. 006-0026 EB and 006-0027 WB. Built as F.A. Rte. 80 Section 06-7B, in 1963. The superstructures consist of 294'-0" (0026) and 340'-9 1/2" (0027) (back to back of abutments) by 35'-8" wide reinforced concrete decks on Rolled Steel Beams supported on pile bent spill through abutments and hammer head piers. Existing structures to be removed and replaced using crossovers.

Salvage: None.

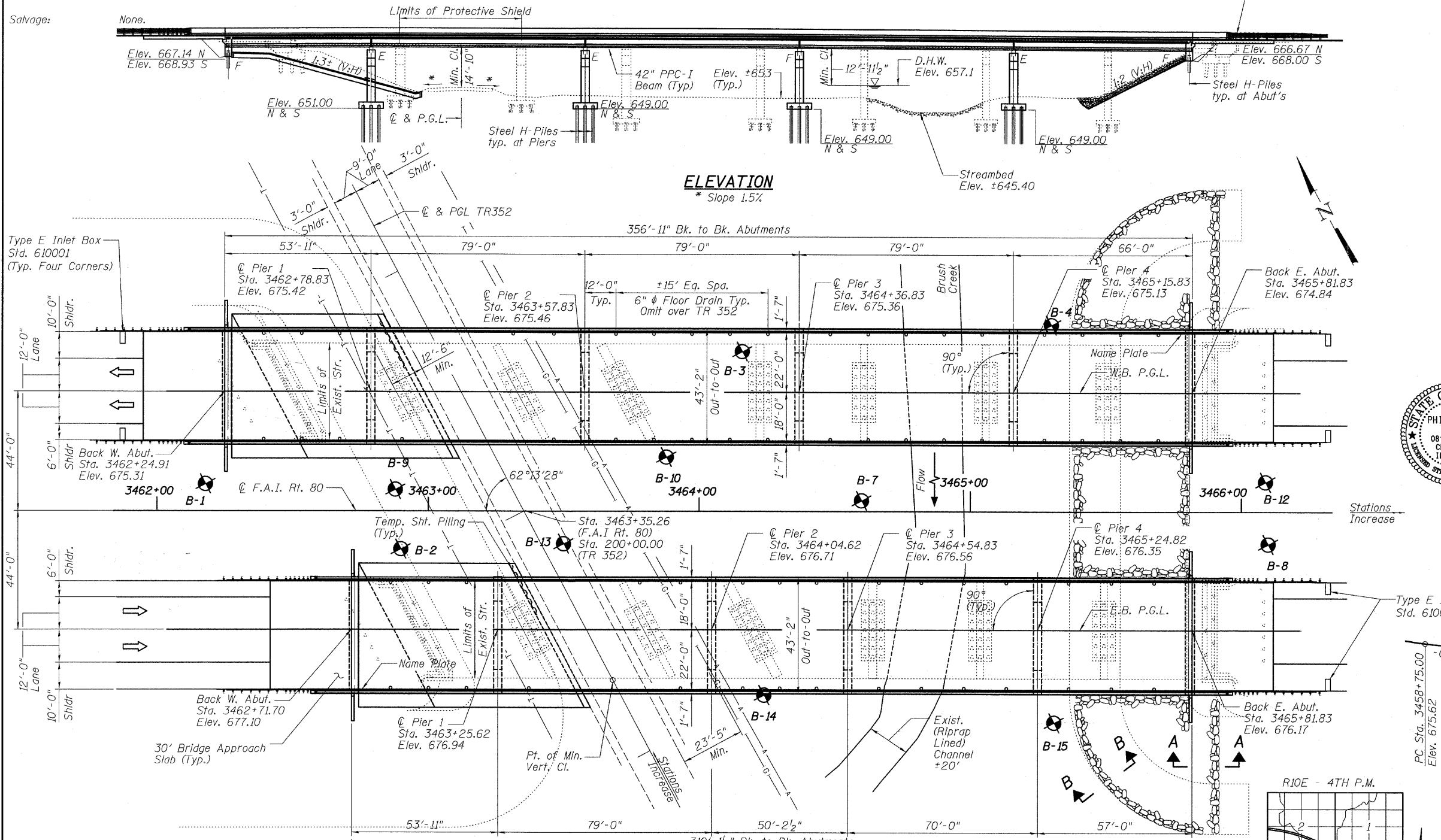

Traffic Barrier Terminal Type 6  
Std. 631031, Typ. all corners  
See Roadway Plans

**DESIGN SPECIFICATION**  
AASHTO 2002 Standard Specifications  
for Highway Bridges

**LOADING HS20-44 & ALT.**  
Allow 50#/sq. ft. for future wearing surface.

**SEISMIC DATA**  
Seismic Performance Category (SPC) = A  
Bedrock Acceleration Coefficient = 0.036  
Site Coefficient = 1

**DESIGN STRESSES**  
**FIELD UNITS**  
f'c = 3,500 psi  
fy = 60,000 psi (Reinforcement)

**PRECAST PRESTRESSED UNITS**  
f'c = 6,000 psi  
f'ci = 5,000 psi  
f's = 270,000 psi (1/2" φ low Relax. strands)  
fsl = 201,960 psi (1/2" φ low Relax. strands)

NOTE:  
For Waterway Information Table and  
Design Scour Table, See Sheet 2 of 59.

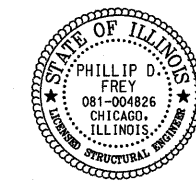

Signed Phillip D. Frey  
Phillip D. Frey, S.E. II, Lic. No. 081-004826  
Expires 11-30-2010.  
Date 9-4-09

**APPROVED**  
FOR STRUCTURAL ADEQUACY ONLY  
Ralph E. Anderson  
ENGINEER OF BRIDGES AND STRUCTURES

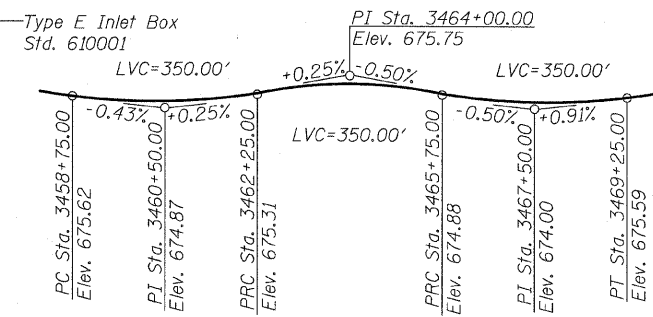

**PROFILE GRADE - I-80 WESTBOUND**

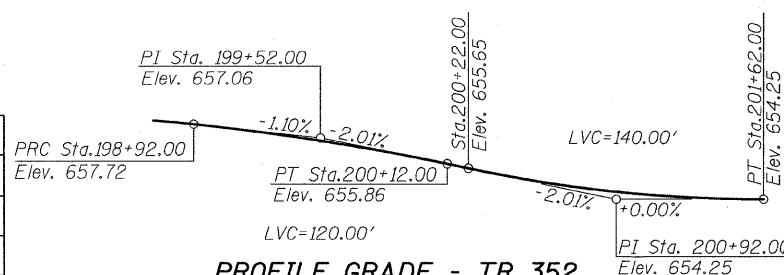

**PROFILE GRADE - TR 352**

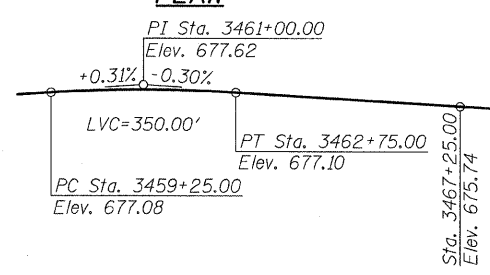

**PROFILE GRADE - I-80 EASTBOUND**

- LEGEND**
- A — Exist. Aerial Line
  - G — Exist. Underground Gas Line
  - T — Exist. Underground Telephone
  - ⊙ Boring Location
  - N North Bridge
  - S South Bridge

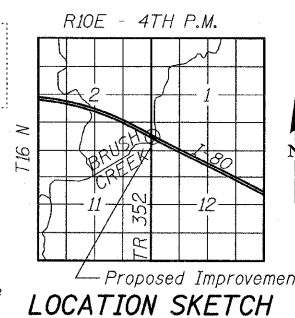

**LOCATION SKETCH**

DESIGNED - SP
CHECKED - PDF
DRAWN - MF, SP
CHECKED - PDF

SHEET NO. 1	F.A. RTE. 80	SECTION *	COUNTY BUREAU	TOTAL SHEETS 344	SHEET NO. 95
59 SHEETS					
CONTRACT NO. 66908					
FED. ROAD DIST. NO. ILLINOIS FED. AID PROJECT					

TYLIN INTERNATIONAL

STATE OF ILLINOIS  
DEPARTMENT OF TRANSPORTATION

**GENERAL NOTES**

1. Reinforcement bars shall conform to the requirements of ASTM A 706 Gr 60. See Special Provisions.
2. Reinforcement bars designated (E) shall be epoxy coated.
3. The existing structural steel coating contains lead. The Contractor shall take appropriate precautions to deal with the presence of lead on this project.
4. Layout of slope protection system may be varied in the field to suit ground conditions as directed by the Engineer.
5. The Contractor shall drive test piles to 110% of the nominal required bearing specified in production locations at substructures specified or approved by the Engineer before ordering the remainder of piles.
6. Concrete Sealer shall be applied to the exposed area of the traffic face side of Pier 1.
7. Slope wall shall be reinforced with welded wire fabric, 6in. x 6in. W4.0 x W4.0, weighing 58lbs. per 100 sq. ft.

**INDEX OF SHEETS**

- 1 GENERAL PLAN
- 2 GENERAL NOTES, INDEX OF SHEETS & BILL OF MATERIAL
- 3 MISCELLANEOUS DETAILS
- 4-7 TOP OF SLAB ELEVATIONS - EASTBOUND
- 8 TOP OF APPROACH SLAB ELEVATIONS - EASTBOUND
- 9-12 TOP OF SLAB ELEVATIONS - WESTBOUND
- 13 TOP OF APPROACH SLAB ELEVATIONS - WESTBOUND
- 14 SUPERSTRUCTURE - EASTBOUND
- 15-16 SUPERSTRUCTURE DETAILS - EASTBOUND
- 17 SUPERSTRUCTURE - WESTBOUND
- 18-19 SUPERSTRUCTURE DETAILS - WESTBOUND
- 20 PIER DIAPHRAGM DETAILS
- 21 ABUTMENT DIAPHRAGM DETAILS
- 22 CONCRETE PARAPET SLIPFORMING OPTION
- 23-24 APPROACH SLAB DETAILS - EASTBOUND
- 25-26 APPROACH SLAB DETAILS - WESTBOUND
- 27 FRAMING PLAN - EASTBOUND
- 28-33 PPC I-BEAM DETAILS - EASTBOUND
- 34 FRAMING PLAN - WESTBOUND
- 35-38 PPC I-BEAM DETAILS - WESTBOUND
- 39 BEARINGS
- 40 EAST ABUTMENT - EASTBOUND
- 41 WEST ABUTMENT - EASTBOUND
- 42 EAST ABUTMENT - WESTBOUND
- 43 WEST ABUTMENT - WESTBOUND
- 44 PIER 1 - EASTBOUND
- 45 PIER 2 - EASTBOUND
- 46 PIER 3 - EASTBOUND
- 47 PIER 4 - EASTBOUND
- 48 PIER 1 - WESTBOUND
- 49 PIER 2 - WESTBOUND
- 50 PIER 3 - WESTBOUND
- 51 PIER 4 - WESTBOUND
- 52 BAR SPLICER (COUPLER) DETAILS
- 53 STEEL PILE DETAILS
- 54-59 BORING LOGS

**TOTAL BILL OF MATERIAL**

ITEM	UNIT	SN 006-0170 (EB)		SN 006-0171 (WB)		TOTAL
		SUPER	SUB	SUPER	SUB	
Porous Granular Embankment (Special)	Cu Yd		168		168	336
Removal of Existing Structures	Each					2
Protective Shield	Sq Yd		177		177	354
Structure Excavation	Cu Yd		473.7		500.7	974.4
Floor Drains	Each	30		38		68
Concrete Structures	Cu Yd		423.0		410.6	833.6
Concrete Superstructure	Cu Yd	612.5		672.5		1285.0
Bridge Deck Grooving	Sq Yd	1563		1761		3324
Concrete Encasement	Cu Yd		8.2		8.2	16.4
Protective Coat	Sq Yd	2031		2168		4199
Furnishing and Erecting Precast Prestressed Concrete I-Beams, 42 in.	Foot	2135.9		2463.4		4599.3
Reinforcement Bars, Epoxy Coated	Pound	121,890	42,230	135,430	41,250	340,800
Bar Splicers	Each	88		88		176
Slope Wall 4 inch	Sq Yd		465		455	920
Furnishing Steel Pile, HP 14x73	Foot		3206		3601	6807
Driving Piles	Foot		3206		3601	6807
Test Pile Steel, HP 14x73	Each		6		6	12
Temporary Sheet Piling	Sq Ft		321		202	523
Name Plates	Each	1		1		2
Elastomeric Bearing Assembly, Type I	Each	28		28		56
Elastomeric Bearing Assembly, Type II	Each	14		14		28
Anchor Bolts, 1/4"	Each	84		84		168
Concrete Sealer	Sq Ft		410		410	820
Geocomposite Wall Drain	Sq Yd		88		88	176
Pipe Underdrain for Structures 4"	Foot		135		135	270
Stone Riprap, Class A4	Sq Yd		661		610	1271
Hot-Mix Asphalt Surface Removal (Asbestos)	Sq Yd	980		1136		2116
Filter Fabric	Sq Yd		661		610	1271

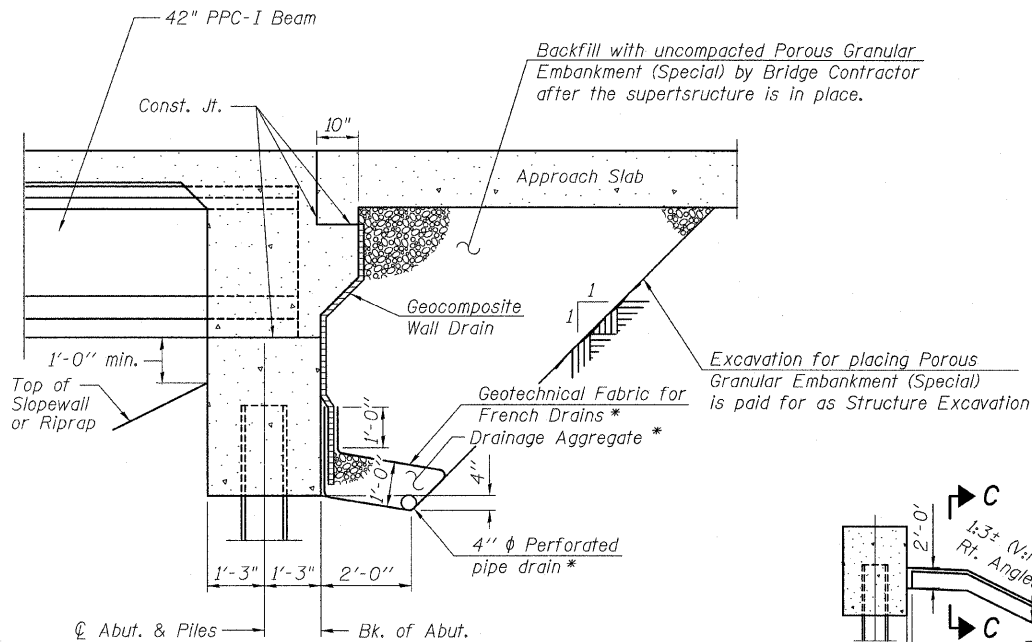

**SECTION THRU ABUTMENT**

\*Included in the cost of Pipe Underdrains for Structures.

All drainage system components shall extend 2'-0" from the end of each wingwall except an outlet pipe shall extend until intersecting with the side slopes. The pipes shall drain into concrete headwalls. (See Article 601.05 of the Standard Specifications and Highway Standard 60110.)

DESIGNED	- SP
CHECKED	- PDF
DRAWN	- SP
CHECKED	- PDF

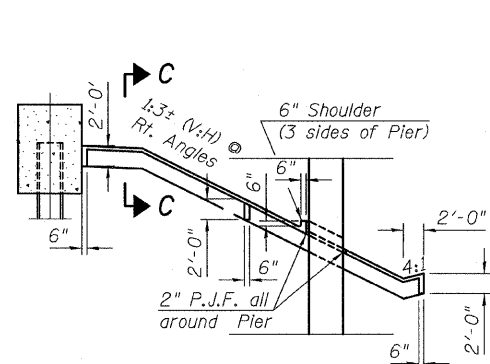

**SECTION THRU SLOPEWALL**

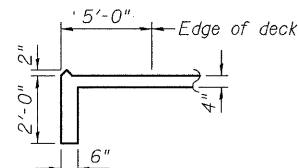

**SECTION C-C**

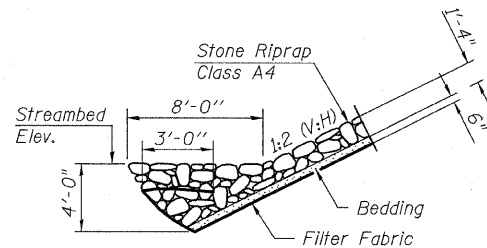

**SECTION B-B**

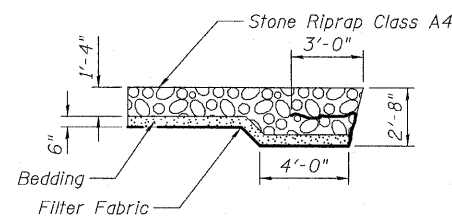

**SECTION A-A**

**DESIGN SCOUR ELEVATION TABLE**

Design Scour Elevation (ft.)	W. Abuts.	Pier 1	Pier 2	Pier 3	Pier 4	E. Abuts.
N - 667.14	651.00	645.00	645.00	645.00	645.70	N - 666.67
S - 668.93	651.00	645.00	645.00	645.00	645.00	S - 668.00

**WATERWAY INFORMATION**

Drainage Area = 37.7 Sq. Mi. Low Grade Elev. 674.76 Ft. @ Sta. 3466+00.00

Flood	Freq. Yr.	Q C.F.S.	Opening Sq. Ft. Exist. Prop.	Nat. H.W.E.	Head - Ft. Exist. Prop.	Headwater El. Exist. Prop.
Design	50	4781	902 1104	657.1	0.8 0.5	658.0 657.6
Base	100	5579	991 1219	657.6	1.1 0.8	658.7 658.4
Overtopping	-	-	-	-	-	-
Max. Calc.	500	7525	1184 1468	658.6	1.8 1.6	660.5 660.2

STATION 3463+35.26  
BUILT 201. BY  
STATE OF ILLINOIS  
F.A.I. RT. 80 SEC. 06-7BR  
LOADING HS20 & ALT.  
STR. NO. 006-0171

STATION 3463+35.26  
BUILT 201. BY  
STATE OF ILLINOIS  
F.A.I. RT. 80 SEC. 06-7BR  
LOADING HS20 & ALT.  
STR. NO. 006-0170

**NAME PLATE WESTBOUND**  
See Std. 515001

**NAME PLATE EASTBOUND**  
See Std. 515001

**GENERAL NOTES, INDEX & BILL OF MATERIAL**  
**STRUCTURE NO. 006-0170 EB**  
**STRUCTURE NO. 006-0171 WB**

SHEET NO. 2	F.A. RTE. 80	SECTION *	COUNTY BUREAU	TOTAL SHEETS 344	SHEET NO. 96
59 SHEETS	FED. ROAD DIST. NO. ILLINOIS		CONTRACT NO. 66908		
FED. ROAD DIST. NO.		ILLINOIS FED. AID PROJECT			

TYLIN INTERNATIONAL

\* 06-17BR & BR-1,7VB-M, 6BR & 6, 7 RS-1 & 1J



STATE OF ILLINOIS  
DEPARTMENT OF TRANSPORTATION

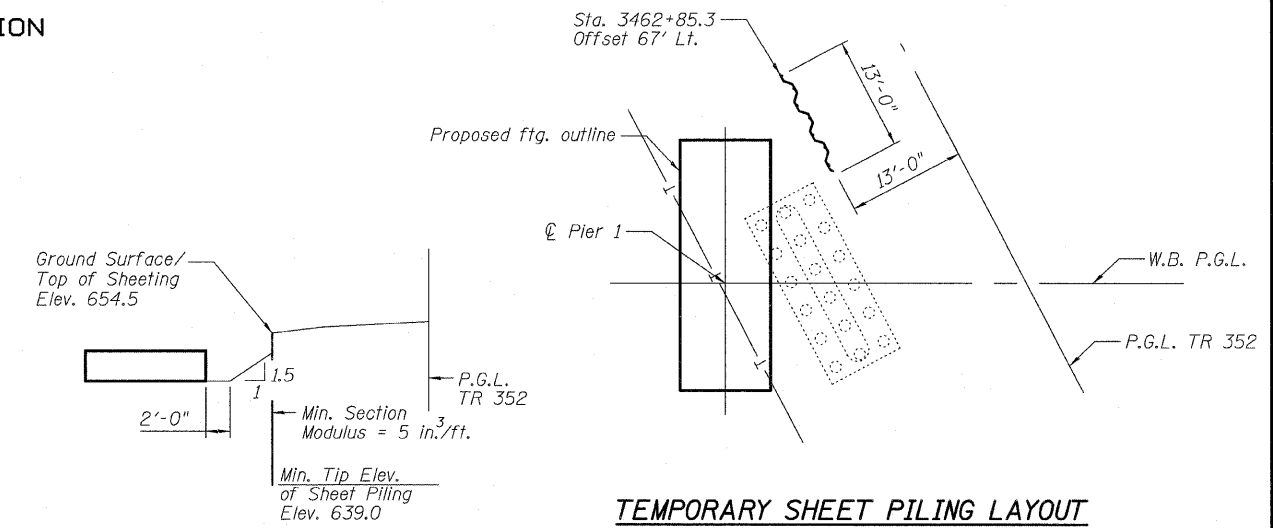
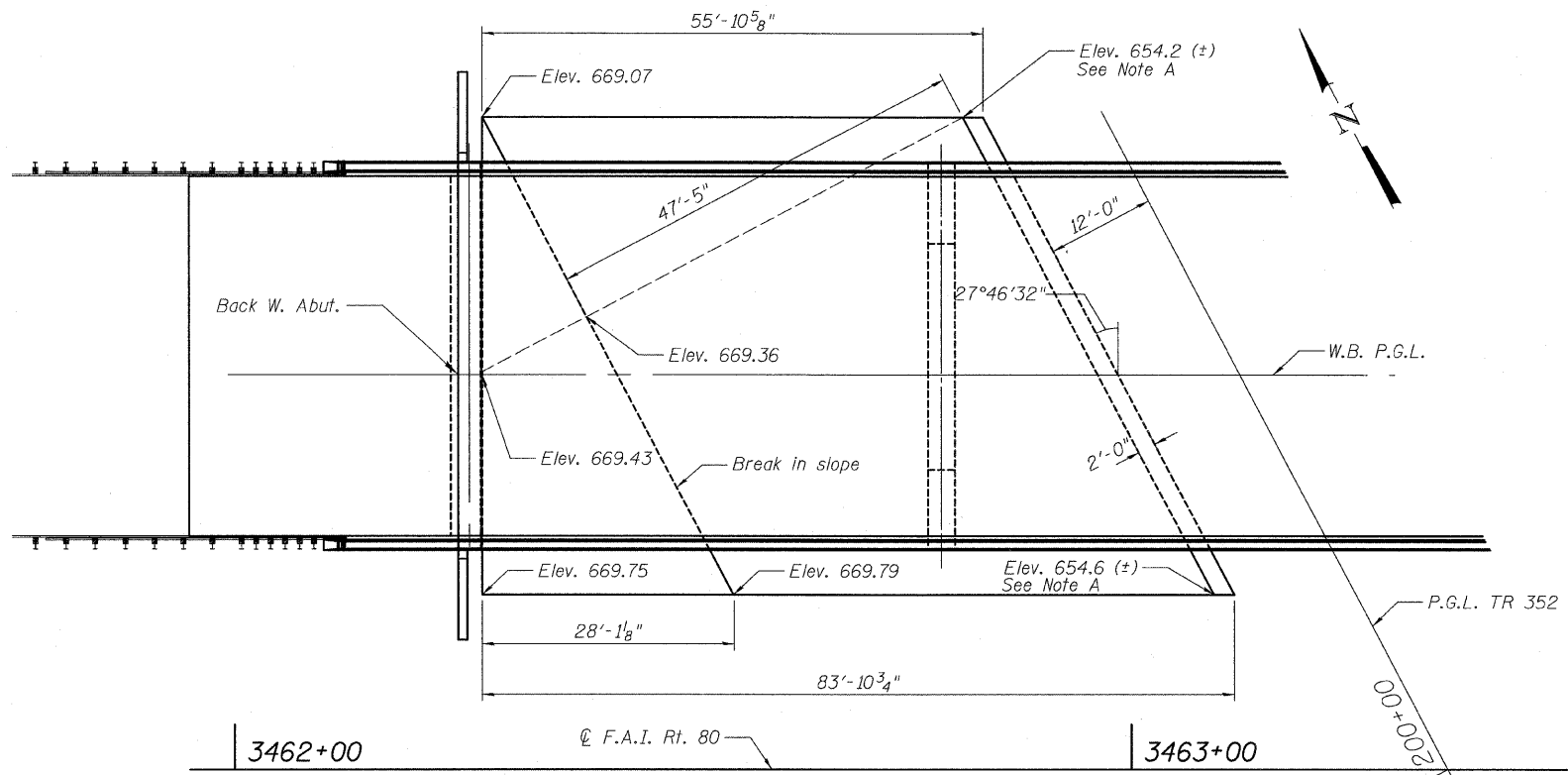

**ELEVATION - TEMPORARY SHEET PILING**  
(S.N. 006-0171 WB Bridge)

**TEMPORARY SHEET PILING LAYOUT**  
(S.N. 006-0171 WB Bridge)

Note A:  
Existing ditch elevation taken from existing plans. Contractor shall modify slope wall to fit actual field conditions.

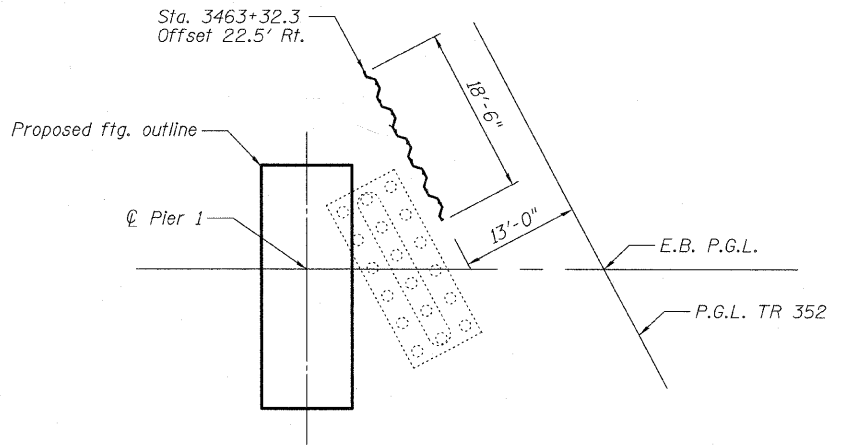
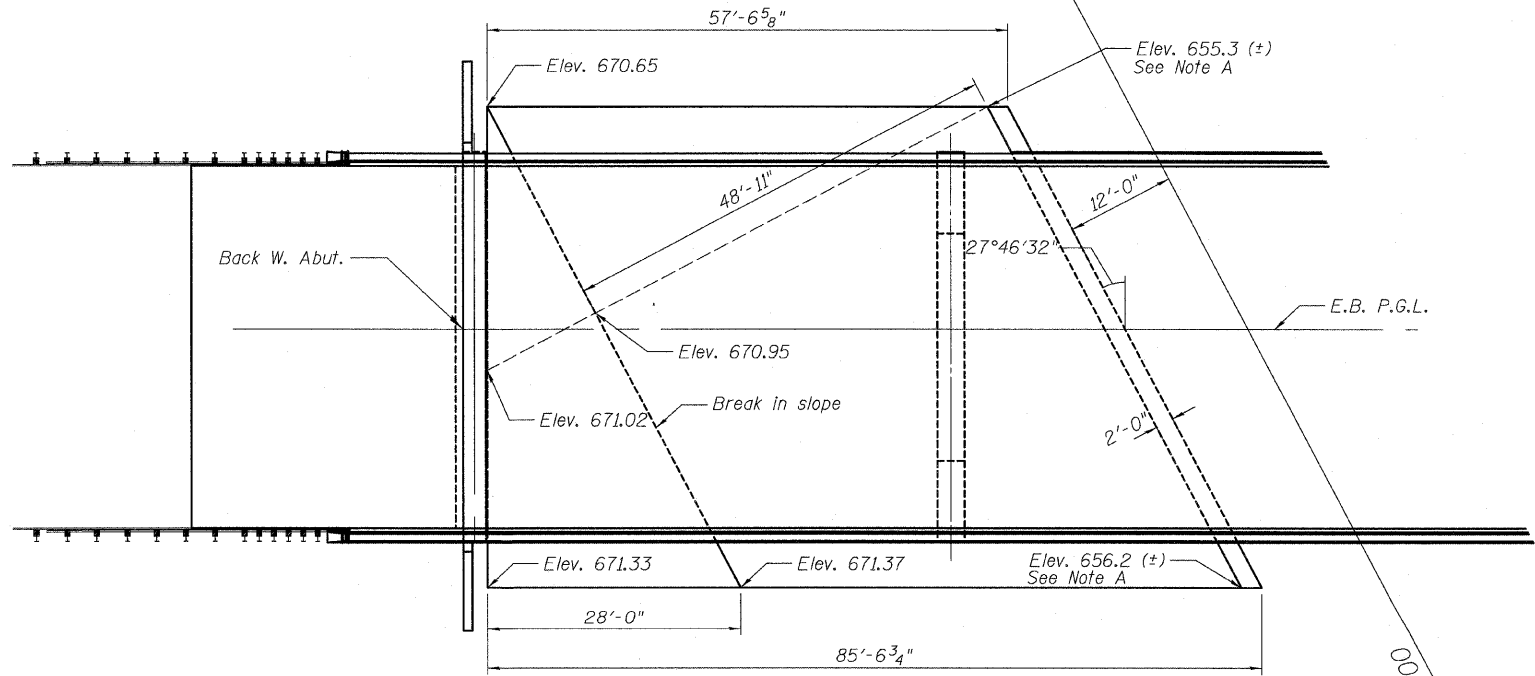

**ELEVATION - TEMPORARY SHEET PILING**  
(S.N. 006-0170 EB Bridge)

**TEMPORARY SHEET PILING LAYOUT**  
(S.N. 006-0170 EB Bridge)

DESIGNED	- SP
CHECKED	- PDF
DRAWN	- SP
CHECKED	- PDF

**TEMPORARY SHEET PILING NOTES**  
If the Contractor chooses to alter the temporary cantilevered sheet piling design requirements shown on the plans, a design submittal including plan details and calculations will be required for review and acceptance by the Engineer.

**CONCRETE SLOPEWALL LAYOUT PLAN**  
(See Sheet 2 of 59 for cross section)

<b>MISCELLANEOUS DETAILS</b>					
<b>STRUCTURE NO. 006-0170 EB</b>					
<b>STRUCTURE NO. 006-0171 WB</b>					
SHEET NO. 3	F.A. RTE. 80	SECTION *	COUNTY BUREAU	TOTAL SHEETS 244	SHEET NO. 97
59 SHEETS					
CONTRACT NO. 66908					
FED. ROAD DIST. NO. ILLINOIS FED. AID PROJECT					

TYLIN INTERNATIONAL

STATE OF ILLINOIS  
DEPARTMENT OF TRANSPORTATION

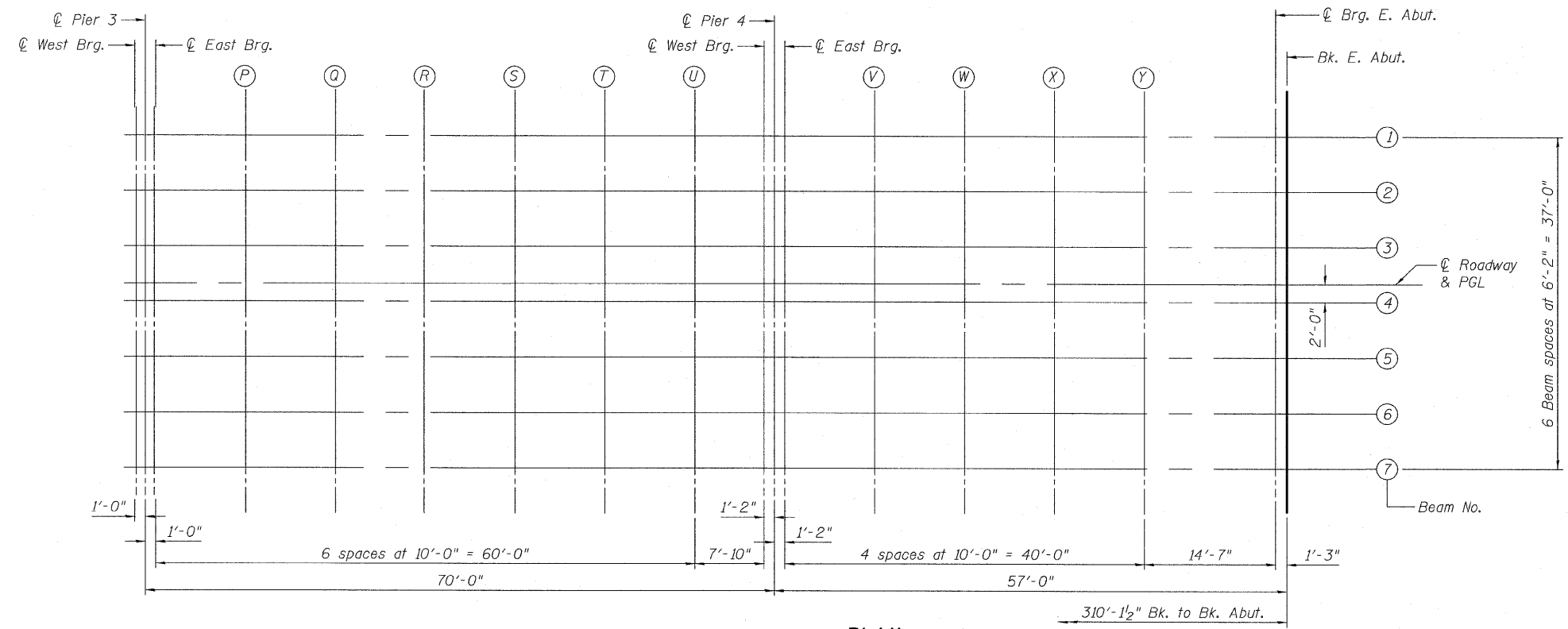
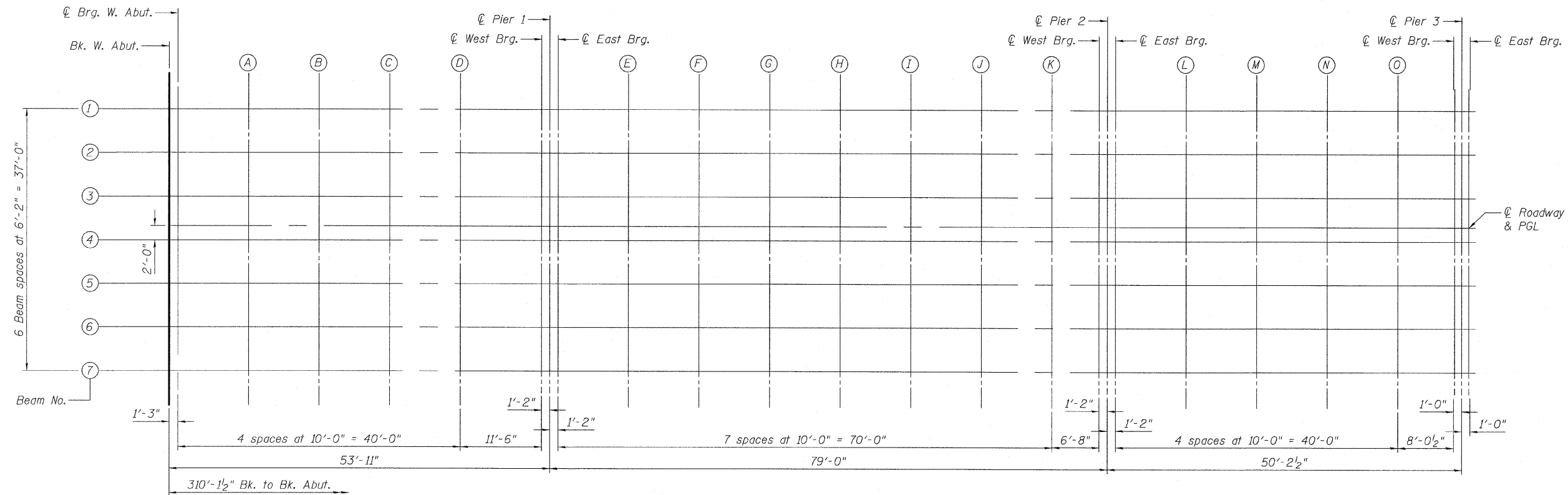

PLAN

TOP OF SLAB ELEVATIONS - 1  
STRUCTURE NO. 006-0170 EB

DESIGNED -	SP
CHECKED -	PDF
DRAWN -	PK
CHECKED -	PDF

SHEET NO. 4 59 SHEETS	F.A. RTE. 80	SECTION *	COUNTY BUREAU	TOTAL SHEETS 344	SHEET NO. 90
	CONTRACT NO. 66908				
FED. ROAD DIST. NO.		ILLINOIS FED. AID PROJECT			

TYLIN INTERNATIONAL

STATE OF ILLINOIS  
DEPARTMENT OF TRANSPORTATION

**BEAM - 1**

Location	Station	Offset	Theoretical Grade Elevations	Theoretical Grade Elevations Adjusted For Dead Load Deflection
BK. W. ABUT	3462+71.70	-16.50	676.82	676.82
☉ BRG. W. ABUT	3462+72.95	-16.50	676.82	676.82
A	3462+82.95	-16.50	676.79	676.80
B	3462+92.95	-16.50	676.76	676.78
C	3463+02.95	-16.50	676.73	676.75
D	3463+12.95	-16.50	676.70	676.72
☉ W. BRG. PIER 1	3463+24.45	-16.50	676.67	676.67
PIER 1	3463+25.62	-16.50	676.66	676.66
☉ E. BRG. PIER 1	3463+26.79	-16.50	676.66	676.66
E	3463+36.79	-16.50	676.63	676.68
F	3463+46.79	-16.50	676.60	676.69
G	3463+56.79	-16.50	676.57	676.68
H	3463+66.79	-16.50	676.54	676.65
I	3463+76.79	-16.50	676.51	676.61
J	3463+86.79	-16.50	676.48	676.56
K	3463+96.79	-16.50	676.45	676.48
☉ W. BRG. PIER 2	3464+03.45	-16.50	676.43	676.43
PIER 2	3464+04.62	-16.50	676.42	676.42
☉ E. BRG. PIER 2	3464+05.79	-16.50	676.42	676.42
L	3464+15.79	-16.50	676.39	676.40
M	3464+25.79	-16.50	676.36	676.38
N	3464+35.79	-16.50	676.33	676.35
O	3464+45.79	-16.50	676.30	676.31
☉ W. BRG. PIER 3	3464+53.83	-16.50	676.28	676.28
PIER 3	3464+54.83	-16.50	676.27	676.27
☉ E. BRG. PIER 3	3464+55.83	-16.50	676.27	676.27
P	3464+65.83	-16.50	676.24	676.28
Q	3464+75.83	-16.50	676.21	676.28
R	3464+85.83	-16.50	676.18	676.26
S	3464+95.83	-16.50	676.15	676.23
T	3465+05.83	-16.50	676.12	676.19
U	3465+15.83	-16.50	676.09	676.13
☉ W. BRG. PIER 4	3465+23.65	-16.50	676.07	676.07
PIER 4	3465+24.82	-16.50	676.06	676.06
☉ E. BRG. PIER 4	3465+25.99	-16.50	676.06	676.06
V	3465+35.99	-16.50	676.03	676.05
W	3465+45.99	-16.50	676.00	676.03
X	3465+55.99	-16.50	675.97	676.00
Y	3465+65.99	-16.50	675.94	675.96
☉ BRG. E. ABUT	3465+80.58	-16.50	675.90	675.90
BK. E. ABUT	3465+81.83	-16.50	675.89	675.89

**BEAM - 2**

Location	Station	Offset	Theoretical Grade Elevations	Theoretical Grade Elevations Adjusted For Dead Load Deflection
BK. W. ABUT	3462+71.70	-10.33	676.94	676.94
☉ BRG. W. ABUT	3462+72.95	-10.33	676.94	676.94
A	3462+82.95	-10.33	676.91	676.92
B	3462+92.95	-10.33	676.88	676.90
C	3463+02.95	-10.33	676.85	676.87
D	3463+12.95	-10.33	676.82	676.84
☉ W. BRG. PIER 1	3463+24.45	-10.33	676.79	676.79
PIER 1	3463+25.62	-10.33	676.78	676.78
☉ E. BRG. PIER 1	3463+26.79	-10.33	676.78	676.78
E	3463+36.79	-10.33	676.75	676.80
F	3463+46.79	-10.33	676.72	676.81
G	3463+56.79	-10.33	676.69	676.80
H	3463+66.79	-10.33	676.66	676.77
I	3463+76.79	-10.33	676.63	676.73
J	3463+86.79	-10.33	676.60	676.68
K	3463+96.79	-10.33	676.57	676.60
☉ W. BRG. PIER 2	3464+03.45	-10.33	676.55	676.55
PIER 2	3464+04.62	-10.33	676.54	676.54
☉ E. BRG. PIER 2	3464+05.79	-10.33	676.54	676.54
L	3464+15.79	-10.33	676.51	676.52
M	3464+25.79	-10.33	676.48	676.50
N	3464+35.79	-10.33	676.45	676.47
O	3464+45.79	-10.33	676.42	676.43
☉ W. BRG. PIER 3	3464+53.83	-10.33	676.40	676.40
PIER 3	3464+54.83	-10.33	676.39	676.39
☉ E. BRG. PIER 3	3464+55.83	-10.33	676.39	676.39
P	3464+65.83	-10.33	676.36	676.40
Q	3464+75.83	-10.33	676.33	676.40
R	3464+85.83	-10.33	676.30	676.38
S	3464+95.83	-10.33	676.27	676.35
T	3465+05.83	-10.33	676.24	676.31
U	3465+15.83	-10.33	676.21	676.25
☉ W. BRG. PIER 4	3465+23.65	-10.33	676.19	676.19
PIER 4	3465+24.82	-10.33	676.18	676.18
☉ E. BRG. PIER 4	3465+25.99	-10.33	676.18	676.18
V	3465+35.99	-10.33	676.15	676.17
W	3465+45.99	-10.33	676.12	676.15
X	3465+55.99	-10.33	676.09	676.12
Y	3465+65.99	-10.33	676.06	676.08
☉ BRG. E. ABUT	3465+80.58	-10.33	676.02	676.02
BK. E. ABUT	3465+81.83	-10.33	676.01	676.01

**BEAM - 3**

Location	Station	Offset	Theoretical Grade Elevations	Theoretical Grade Elevations Adjusted For Dead Load Deflection
BK. W. ABUT	3462+71.70	-4.17	677.04	677.04
☉ BRG. W. ABUT	3462+72.95	-4.17	677.04	677.04
A	3462+82.95	-4.17	677.01	677.02
B	3462+92.95	-4.17	676.98	677.00
C	3463+02.95	-4.17	676.95	676.97
D	3463+12.95	-4.17	676.92	676.93
☉ W. BRG. PIER 1	3463+24.45	-4.17	676.88	676.88
PIER 1	3463+25.62	-4.17	676.88	676.88
☉ E. BRG. PIER 1	3463+26.79	-4.17	676.87	676.87
E	3463+36.79	-4.17	676.84	676.90
F	3463+46.79	-4.17	676.81	676.90
G	3463+56.79	-4.17	676.78	676.89
H	3463+66.79	-4.17	676.75	676.87
I	3463+76.79	-4.17	676.72	676.83
J	3463+86.79	-4.17	676.69	676.77
K	3463+96.79	-4.17	676.66	676.70
☉ W. BRG. PIER 2	3464+03.45	-4.17	676.64	676.64
PIER 2	3464+04.62	-4.17	676.64	676.64
☉ E. BRG. PIER 2	3464+05.79	-4.17	676.64	676.64
L	3464+15.79	-4.17	676.61	676.62
M	3464+25.79	-4.17	676.58	676.60
N	3464+35.79	-4.17	676.55	676.57
O	3464+45.79	-4.17	676.52	676.53
☉ W. BRG. PIER 3	3464+53.83	-4.17	676.49	676.49
PIER 3	3464+54.83	-4.17	676.49	676.49
☉ E. BRG. PIER 3	3464+55.83	-4.17	676.49	676.49
P	3464+65.83	-4.17	676.46	676.50
Q	3464+75.83	-4.17	676.43	676.50
R	3464+85.83	-4.17	676.40	676.48
S	3464+95.83	-4.17	676.37	676.45
T	3465+05.83	-4.17	676.34	676.40
U	3465+15.83	-4.17	676.31	676.34
☉ W. BRG. PIER 4	3465+23.65	-4.17	676.28	676.28
PIER 4	3465+24.82	-4.17	676.28	676.28
☉ E. BRG. PIER 4	3465+25.99	-4.17	676.28	676.28
V	3465+35.99	-4.17	676.25	676.26
W	3465+45.99	-4.17	676.22	676.24
X	3465+55.99	-4.17	676.19	676.21
Y	3465+65.99	-4.17	676.16	676.18
☉ BRG. E. ABUT	3465+80.58	-4.17	676.11	676.11
BK. E. ABUT	3465+81.83	-4.17	676.11	676.11

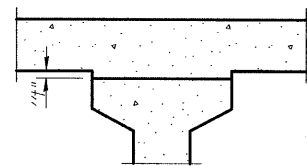

To determine "t": After all precast prestressed beams have been erected, elevations of the top flanges of the beams shall be taken at intervals shown below. These elevations subtracted from the "Theoretical Grade Elevations Adjusted for Dead Load Deflections" shown below, minus slab thickness, equals the fillet heights "t" above top flanges of beams.

**FILLET HEIGHTS**

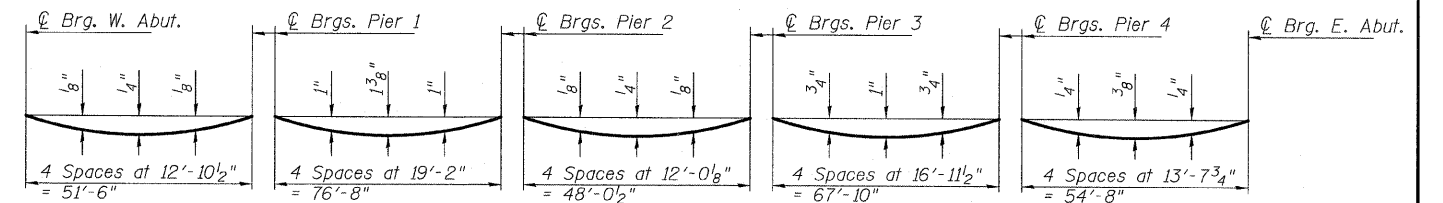

**DEAD LOAD DEFLECTION DIAGRAM**

Note: (Includes weight of concrete, excluding beams).  
The above deflections are not to be used in the field if the engineer is working from the grade elevations adjusted for dead load deflections as shown below.

**TOP OF SLAB ELEVATIONS - 2  
STRUCTURE NO. 006-0170 EB**

DESIGNED - SP
CHECKED - PDF
DRAWN - SP
CHECKED - PDF

SHEET NO. 5 59 SHEETS	F.A. RTE. 80	SECTION *	COUNTY BUREAU	TOTAL SHEETS 344	SHEET NO. 99
	CONTRACT NO. 66908				
FED. ROAD DIST. NO.		ILLINOIS FED. AID PROJECT			

TYLIN INTERNATIONAL

STATE OF ILLINOIS  
DEPARTMENT OF TRANSPORTATION

PGL

Location	Station	Offset	Theoretical Grade Elevations	Theoretical Grade Elevations Adjusted For Dead Load Deflection
BK. W. ABUT	3462+71.70	0.00	677.10	677.10
Q BRG. W. ABUT	3462+72.95	0.00	677.10	677.10
A	3462+82.95	0.00	677.07	677.09
B	3462+92.95	0.00	677.04	677.06
C	3463+02.95	0.00	677.01	677.03
D	3463+12.95	0.00	676.98	677.00
Q W. BRG. PIER 1	3463+24.45	0.00	676.95	676.95
PIER 1	3463+25.62	0.00	676.94	676.94
Q E. BRG. PIER 1	3463+26.79	0.00	676.94	676.94
E	3463+36.79	0.00	676.91	676.96
F	3463+46.79	0.00	676.88	676.97
G	3463+56.79	0.00	676.85	676.96
H	3463+66.79	0.00	676.82	676.93
I	3463+76.79	0.00	676.79	676.89
J	3463+86.79	0.00	676.76	676.84
K	3463+96.79	0.00	676.73	676.77
Q W. BRG. PIER 2	3464+03.45	0.00	676.71	676.71
PIER 2	3464+04.62	0.00	676.71	676.71
Q E. BRG. PIER 2	3464+05.79	0.00	676.70	676.70
L	3464+15.79	0.00	676.67	676.68
M	3464+25.79	0.00	676.64	676.66
N	3464+35.79	0.00	676.61	676.63
O	3464+45.79	0.00	676.58	676.59
Q W. BRG. PIER 3	3464+53.83	0.00	676.56	676.56
PIER 3	3464+54.83	0.00	676.56	676.56
Q E. BRG. PIER 3	3464+55.83	0.00	676.55	676.55
P	3464+65.83	0.00	676.52	676.56
Q	3464+75.83	0.00	676.49	676.56
R	3464+85.83	0.00	676.46	676.55
S	3464+95.83	0.00	676.43	676.51
T	3465+05.83	0.00	676.40	676.47
U	3465+15.83	0.00	676.37	676.41
Q W. BRG. PIER 4	3465+23.65	0.00	676.35	676.35
PIER 4	3465+24.82	0.00	676.35	676.35
Q E. BRG. PIER 4	3465+25.99	0.00	676.34	676.34
V	3465+35.99	0.00	676.31	676.33
W	3465+45.99	0.00	676.28	676.31
X	3465+55.99	0.00	676.25	676.28
Y	3465+65.99	0.00	676.22	676.24
Q BRG. E. ABUT	3465+80.58	0.00	676.18	676.18
BK. E. ABUT	3465+81.83	0.00	676.17	676.17

BEAM - 4

Location	Station	Offset	Theoretical Grade Elevations	Theoretical Grade Elevations Adjusted For Dead Load Deflection
BK. W. ABUT	3462+71.70	2.00	677.07	677.07
Q BRG. W. ABUT	3462+72.95	2.00	677.07	677.07
A	3462+82.95	2.00	677.04	677.05
B	3462+92.95	2.00	677.01	677.03
C	3463+02.95	2.00	676.98	677.00
D	3463+12.95	2.00	676.95	676.97
Q W. BRG. PIER 1	3463+24.45	2.00	676.92	676.92
PIER 1	3463+25.62	2.00	676.91	676.91
Q E. BRG. PIER 1	3463+26.79	2.00	676.91	676.91
E	3463+36.79	2.00	676.88	676.93
F	3463+46.79	2.00	676.85	676.94
G	3463+56.79	2.00	676.82	676.93
H	3463+66.79	2.00	676.79	676.90
I	3463+76.79	2.00	676.76	676.86
J	3463+86.79	2.00	676.73	676.81
K	3463+96.79	2.00	676.70	676.73
Q W. BRG. PIER 2	3464+03.45	2.00	676.68	676.68
PIER 2	3464+04.62	2.00	676.67	676.67
Q E. BRG. PIER 2	3464+05.79	2.00	676.67	676.67
L	3464+15.79	2.00	676.64	676.65
M	3464+25.79	2.00	676.61	676.63
N	3464+35.79	2.00	676.58	676.60
O	3464+45.79	2.00	676.55	676.56
Q W. BRG. PIER 3	3464+53.83	2.00	676.53	676.53
PIER 3	3464+54.83	2.00	676.52	676.52
Q E. BRG. PIER 3	3464+55.83	2.00	676.52	676.52
P	3464+65.83	2.00	676.49	676.53
Q	3464+75.83	2.00	676.46	676.53
R	3464+85.83	2.00	676.43	676.51
S	3464+95.83	2.00	676.40	676.48
T	3465+05.83	2.00	676.37	676.44
U	3465+15.83	2.00	676.34	676.38
Q W. BRG. PIER 4	3465+23.65	2.00	676.32	676.32
PIER 4	3465+24.82	2.00	676.31	676.31
Q E. BRG. PIER 4	3465+25.99	2.00	676.31	676.31
V	3465+35.99	2.00	676.28	676.30
W	3465+45.99	2.00	676.25	676.28
X	3465+55.99	2.00	676.22	676.25
Y	3465+65.99	2.00	676.19	676.21
Q BRG. E. ABUT	3465+80.58	2.00	676.15	676.15
BK. E. ABUT	3465+81.83	2.00	676.14	676.14

BEAM - 5

Location	Station	Offset	Theoretical Grade Elevations	Theoretical Grade Elevations Adjusted For Dead Load Deflection
BK. W. ABUT	3462+71.70	8.17	676.98	676.98
Q BRG. W. ABUT	3462+72.95	8.17	676.97	676.97
A	3462+82.95	8.17	676.94	676.96
B	3462+92.95	8.17	676.91	676.94
C	3463+02.95	8.17	676.88	676.91
D	3463+12.95	8.17	676.85	676.87
Q W. BRG. PIER 1	3463+24.45	8.17	676.82	676.82
PIER 1	3463+25.62	8.17	676.82	676.82
Q E. BRG. PIER 1	3463+26.79	8.17	676.81	676.81
E	3463+36.79	8.17	676.78	676.83
F	3463+46.79	8.17	676.75	676.84
G	3463+56.79	8.17	676.72	676.83
H	3463+66.79	8.17	676.69	676.81
I	3463+76.79	8.17	676.66	676.77
J	3463+86.79	8.17	676.63	676.71
K	3463+96.79	8.17	676.60	676.64
Q W. BRG. PIER 2	3464+03.45	8.17	676.58	676.58
PIER 2	3464+04.62	8.17	676.58	676.58
Q E. BRG. PIER 2	3464+05.79	8.17	676.58	676.58
L	3464+15.79	8.17	676.55	676.56
M	3464+25.79	8.17	676.52	676.53
N	3464+35.79	8.17	676.49	676.50
O	3464+45.79	8.17	676.46	676.47
Q W. BRG. PIER 3	3464+53.83	8.17	676.43	676.43
PIER 3	3464+54.83	8.17	676.43	676.43
Q E. BRG. PIER 3	3464+55.83	8.17	676.42	676.42
P	3464+65.83	8.17	676.39	676.44
Q	3464+75.83	8.17	676.36	676.44
R	3464+85.83	8.17	676.33	676.42
S	3464+95.83	8.17	676.30	676.39
T	3465+05.83	8.17	676.27	676.34
U	3465+15.83	8.17	676.24	676.28
Q W. BRG. PIER 4	3465+23.65	8.17	676.22	676.22
PIER 4	3465+24.82	8.17	676.22	676.22
Q E. BRG. PIER 4	3465+25.99	8.17	676.21	676.21
V	3465+35.99	8.17	676.18	676.20
W	3465+45.99	8.17	676.15	676.18
X	3465+55.99	8.17	676.12	676.15
Y	3465+65.99	8.17	676.09	676.12
Q BRG. E. ABUT	3465+80.58	8.17	676.05	676.05
BK. E. ABUT	3465+81.83	8.17	676.05	676.05

DESIGNED - SP
CHECKED - PDF
DRAWN - SP
CHECKED - PDF

TOP OF SLAB ELEVATIONS - 3  
STRUCTURE NO. 006-0170 EB

SHEET NO. 6	F.A. RTE.	SECTION	COUNTY	TOTAL SHEETS	SHEET NO.
	80	*	BUREAU	344	100
59 SHEETS	FED. ROAD DIST. NO.		ILLINOIS FED. AID PROJECT		CONTRACT NO. 66908

TYLIN INTERNATIONAL