

F.A.P. RTE.	SECTION	COUNTY	TOTAL SHEETS	SHEET NO.
808	.	**	715	307

- (205,57,105)RS-2
- CHAMPAIGN & DOUGLAS

TYPICAL DETAIL OF RURAL FIELD ENTRANCES

(ADJACENT TO IL RTE. 130)

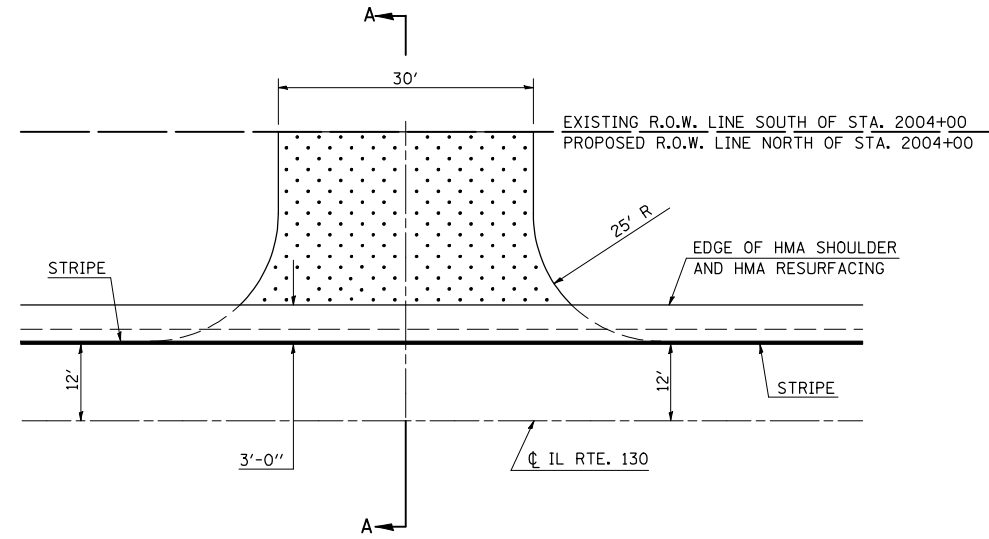

PLAN

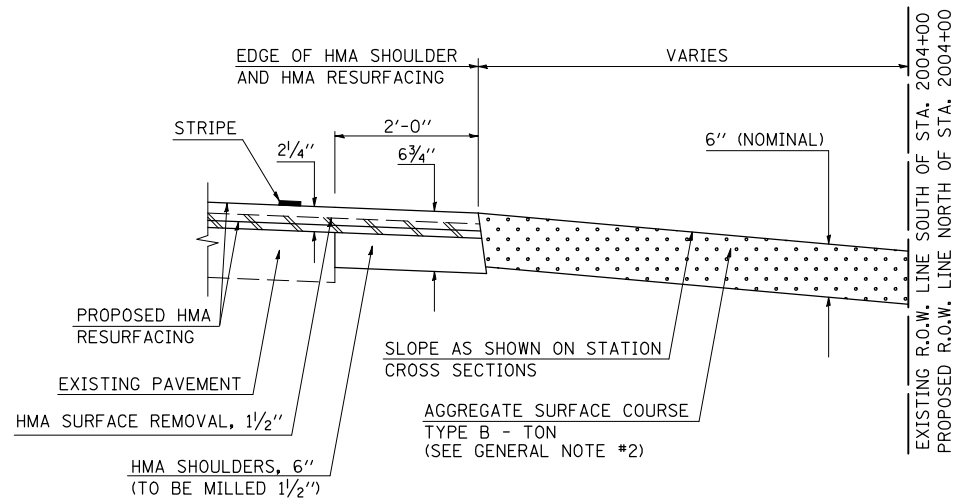

PROFILE
(SECTION A-A)

GENERAL NOTES

- 1) THE EXISTING SURFACE SHALL BE PREPARED IN ACCORDANCE WITH SECTION 402 OF THE STANDARD SPECIFICATIONS.
- 2) EARTH EXCAVATION REQUIRED FOR THE CONSTRUCTION OF THE AGGREGATE SURFACE COURSE SHALL BE INCLUDED IN THE COST OF AGGREGATE SURFACE COURSE, TYPE B.
- 3) THE ENTRANCE SHOULDER WIDTH SHALL BE 2 FT. THE ENTRANCE SHOULDER SLOPE SHALL BE 4%. THE ENTRANCE SIDESLOPES SHALL BE 1:4 (FT).
- 4) EXISTING FIELD ENTRANCES OF AGGREGATE OR EARTH WITH NO HMA APRON SHALL NOT RECEIVE A NEW HMA APRON WITHOUT PROPER APPROVAL THROUGH THE BUREAU OF OPERATIONS "POLICY ON PERMITS FOR ACCESS DRIVEWAYS TO STATE HIGHWAYS".
- 5) TO ASSURE APPROPRIATE ACCESS POLICIES ARE FOLLOWED, ALL NEW ACCESS SHALL BE APPLIED FOR THROUGH THE BUREAU OF OPERATIONS PERMIT APPLICATION PROCESS. PLAN PREPARATION MEMORANDUMS 40-09 AND 40-11 ALONG WITH DISTRICT CONSTRUCTION MEMORANDUM 03/14 DISCUSS THIS PROCEDURE.

TYPICAL DETAIL OF RURAL FIELD ENTRANCES

(ADJACENT TO SIDEROADS)

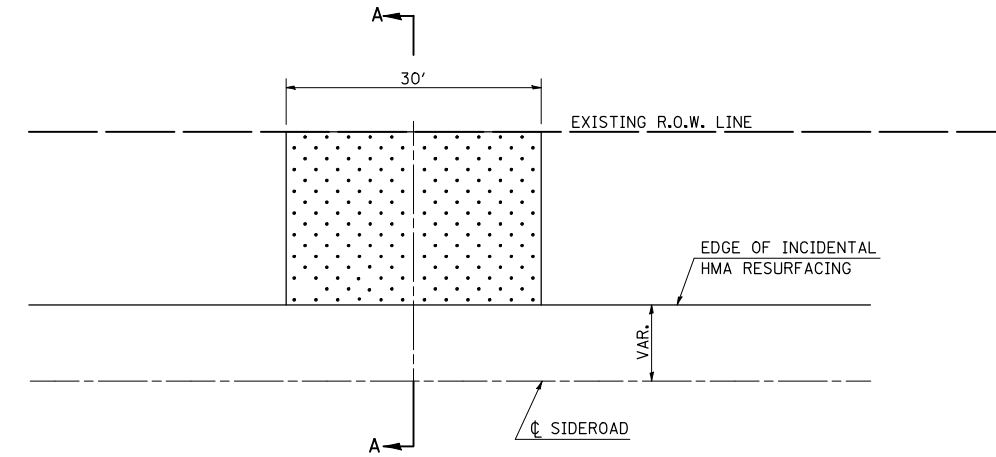

PLAN

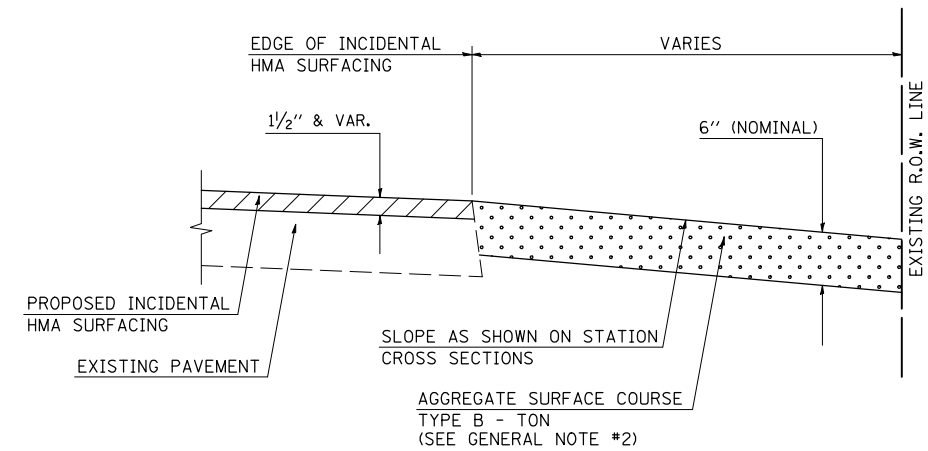

PROFILE
(SECTION A-A)

GENERAL NOTES

- 1) THE EXISTING SURFACE SHALL BE PREPARED IN ACCORDANCE WITH SECTION 402 OF THE STANDARD SPECIFICATIONS.
- 2) EARTH EXCAVATION REQUIRED FOR THE CONSTRUCTION OF THE AGGREGATE SURFACE COURSE SHALL BE INCLUDED IN THE COST OF AGGREGATE SURFACE COURSE, TYPE B.
- 3) THE ENTRANCE SHOULDER WIDTH SHALL BE 2 FT. THE ENTRANCE SHOULDER SLOPE SHALL BE 4%. THE ENTRANCE SIDESLOPES SHALL BE 1:4 (FT).
- 4) EXISTING FIELD ENTRANCES OF AGGREGATE OR EARTH WITH NO HMA APRON SHALL NOT RECEIVE A NEW HMA APRON WITHOUT PROPER APPROVAL THROUGH THE BUREAU OF OPERATIONS "POLICY ON PERMITS FOR ACCESS DRIVEWAYS TO STATE HIGHWAYS".
- 5) TO ASSURE APPROPRIATE ACCESS POLICIES ARE FOLLOWED, ALL NEW ACCESS SHALL BE APPLIED FOR THROUGH THE BUREAU OF OPERATIONS PERMIT APPLICATION PROCESS. PLAN PREPARATION MEMORANDUMS 40-09 AND 40-11 ALONG WITH DISTRICT CONSTRUCTION MEMORANDUM 03/14 DISCUSS THIS PROCEDURE.