

**DETAILS OF MAILBOX TURNOUTS**

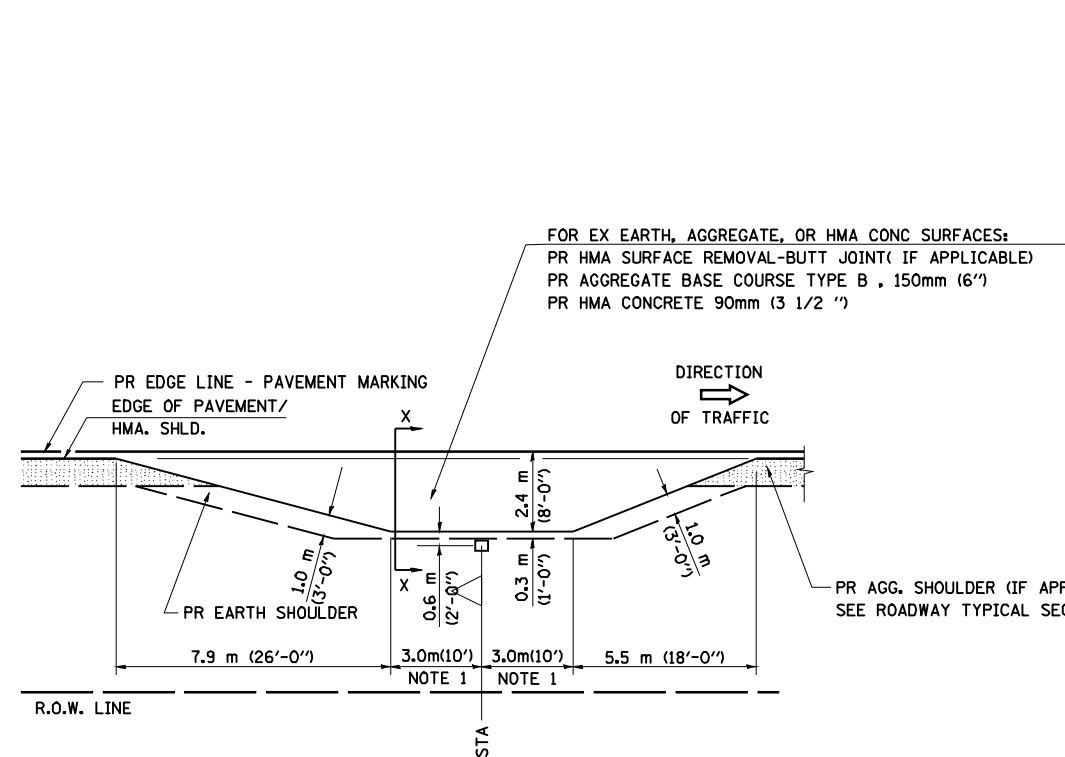

**PLAN - MAILBOX TURNOUTS**

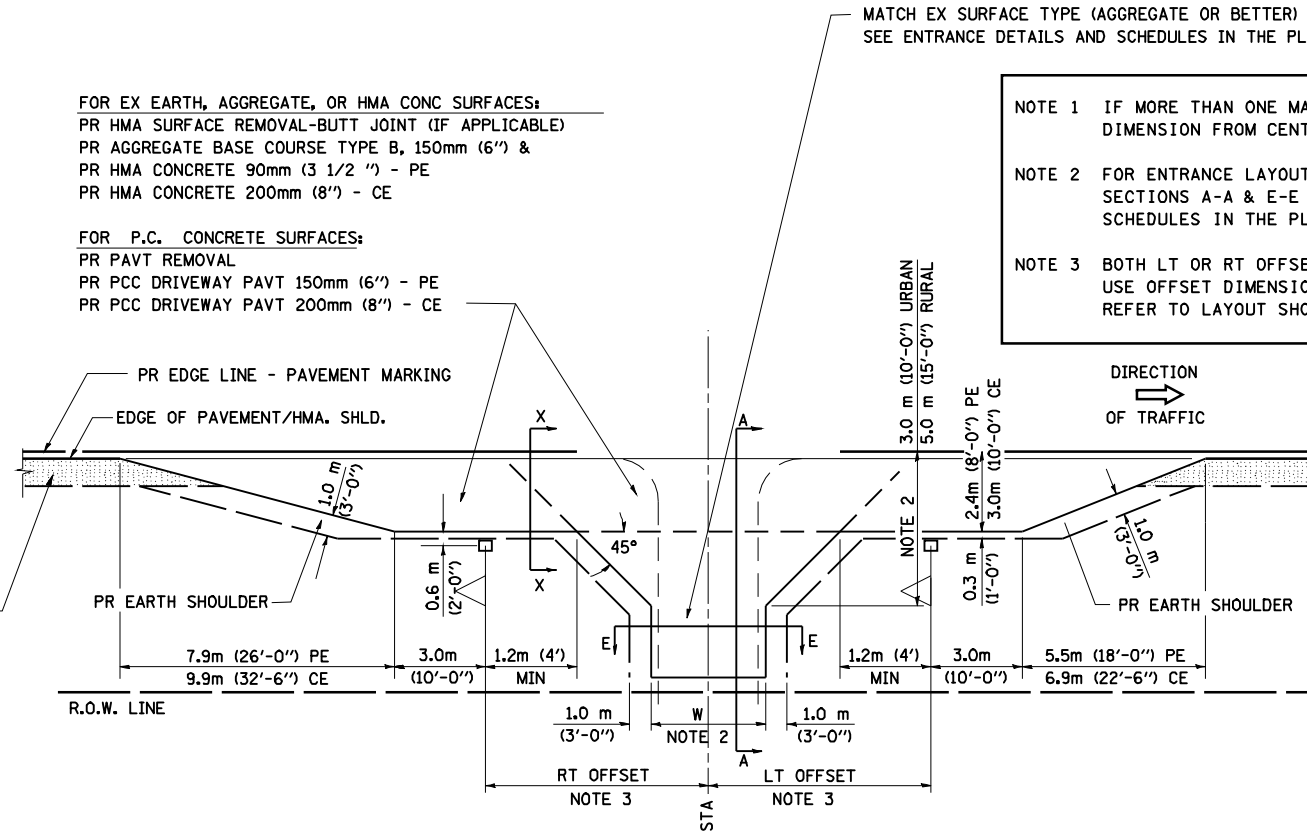

**PLAN - COMBINED MAILBOX TURNOUT WITH TRAILING OR LEADING ENTRANCE**

NOTE 1 IF MORE THAN ONE MAILBOX IS PRESENT, DIMENSION FROM CENTER OF END MAILBOX.

NOTE 2 FOR ENTRANCE LAYOUT DIMENSIONS AND SECTIONS A-A & E-E REFER TO THE SCHEDULES IN THE PLANS.

NOTE 3 BOTH LT OR RT OFFSETS FOR MAILBOX SHOWN USE OFFSET DIMENSION PER SCHEDULE AND REFER TO LAYOUT SHOWN ON THE PLAN.

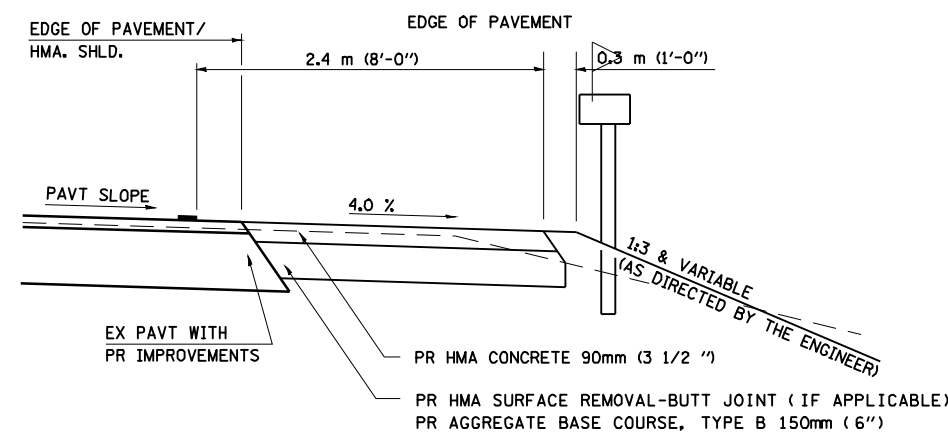

**SECTION X-X THRU MAILBOX TURNOUT  
 ALSO APPLIES TO MAILBOX TURNOUTS COMBINED WITH  
 EX EARTH, AGGREGATE, OR HMA PE & FE**

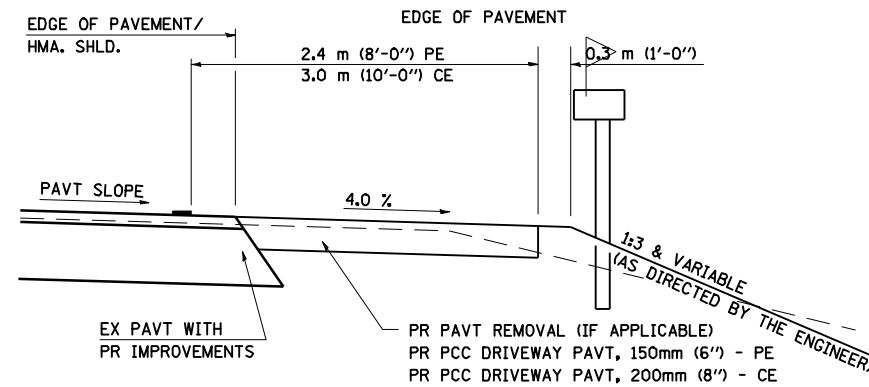

**SECTION X-X THRU MAILBOX TURNOUT  
 COMBINED WITH EX CONC PE OR CE**

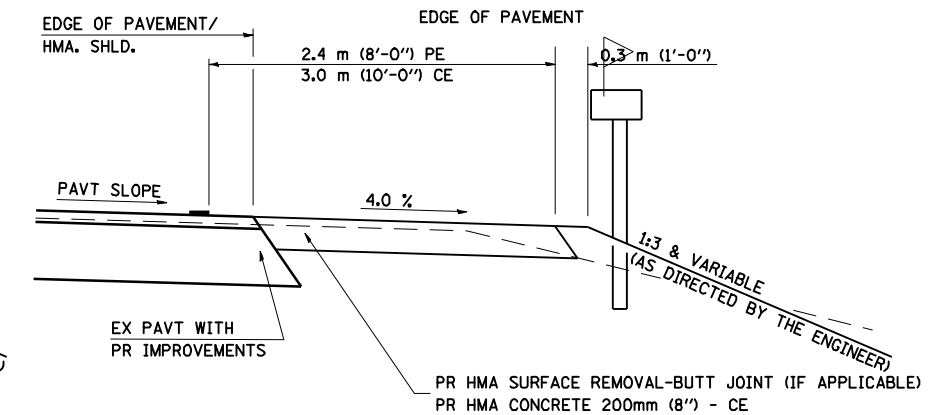

**SECTION X-X THRU MAILBOX TURNOUT  
 COMBINED WITH EX EARTH, AGGREGATE, OR HMA CE**

FILE NAME =	USER NAME = madon1avj	DESIGNED -	REVISED -	2/19/03
S:\PROJ ENGR 1 (Negongard)\Dust Squad\FAP	662 (IL 4) Henderson.pdf\CADD Sheets\06727	DRAWN -	REVISED -	4/01/04
	PLOT SCALE = 48.0002' / IN.	CHECKED -	REVISED -	8/01/07
	PLOT DATE = Aug-17-2009 04:06:59PM	DATE -	REVISED -	



**Allen Henderson & Associates, Inc.**  
 Civil and Structural Engineers Springfield, IL  
 62703 Phone: (217)544-8033 IL Design Firm  
 No. 184-001907

<b>DISTRICT SIX DETAILS FOR RURAL/URBAN ENTRANCE          &amp; MAILBOX TURNOUT W/O CONCRETE GUTTER (3R-PROJECTS)</b>	
SCALE: NONE	SHEET NO. 2 OF 6 SHEETS
STA.	TO STA.

F.A.P. RTE.	SECTION	COUNTY	TOTAL SHEETS	SHEET NO.
662	D(W-3,RS-11,CR)	MACOUPIN	102	59
FED. ROAD DIST. NO.			ILLINOIS FED. AID PROJECT	
			CONTRACT NO. 72765	

D-98-506-07