

STATE OF ILLINOIS  
DEPARTMENT OF TRANSPORTATION

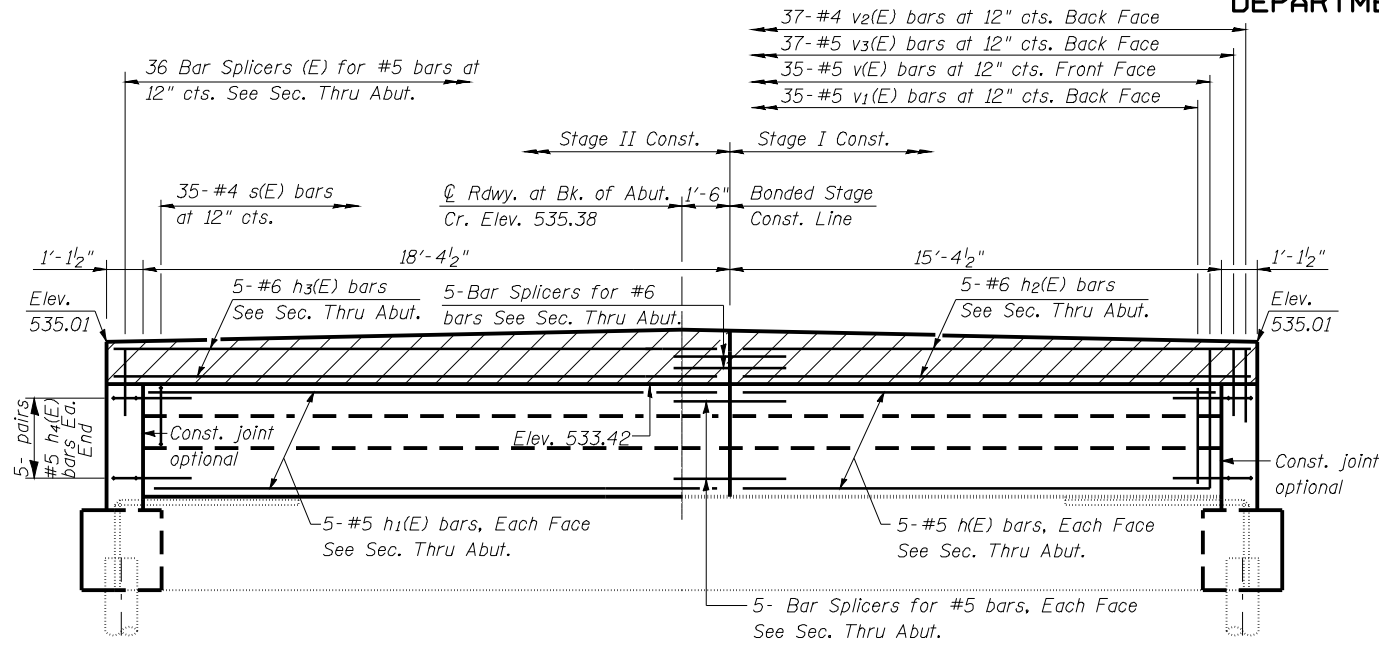

**ELEVATION**  
(Looking South)

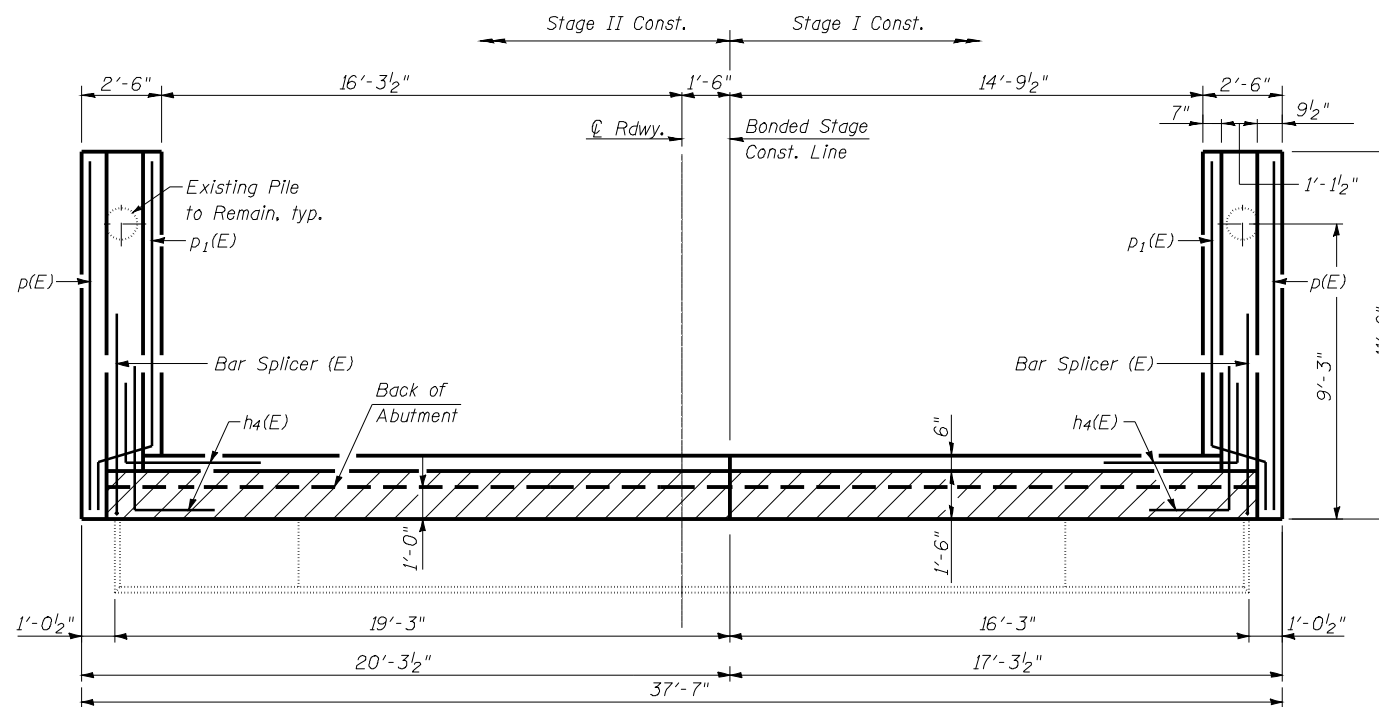

**TOP VIEW**

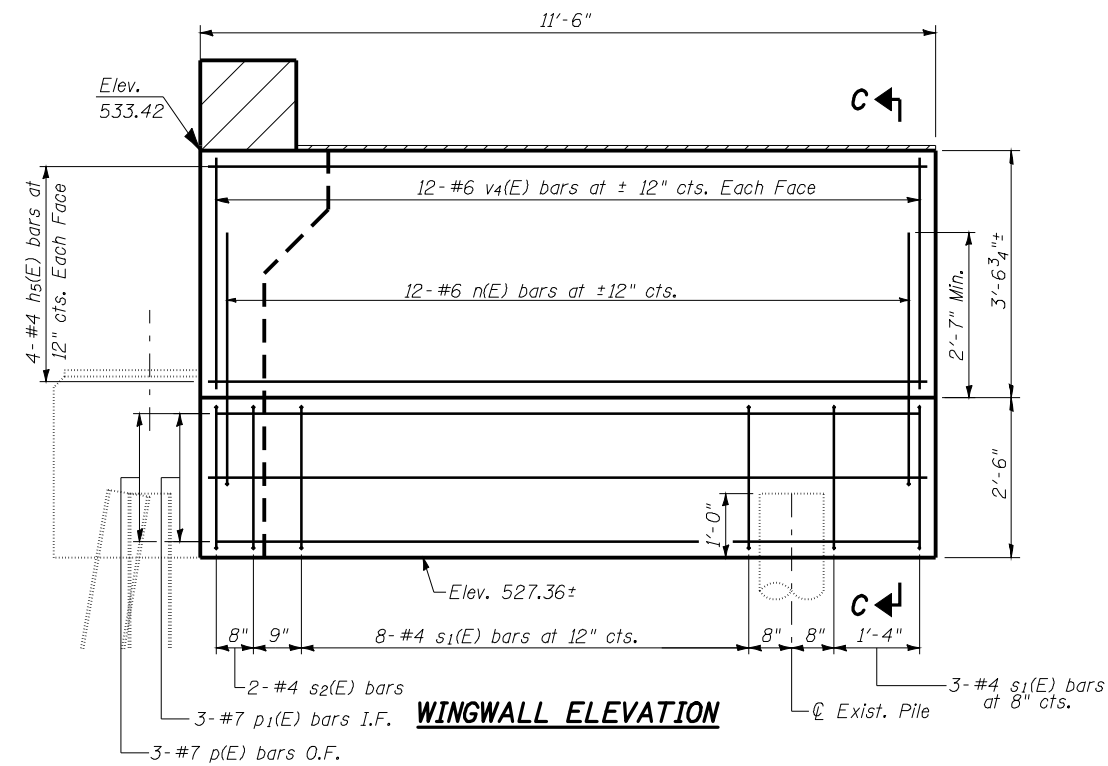

**WINGWALL ELEVATION**

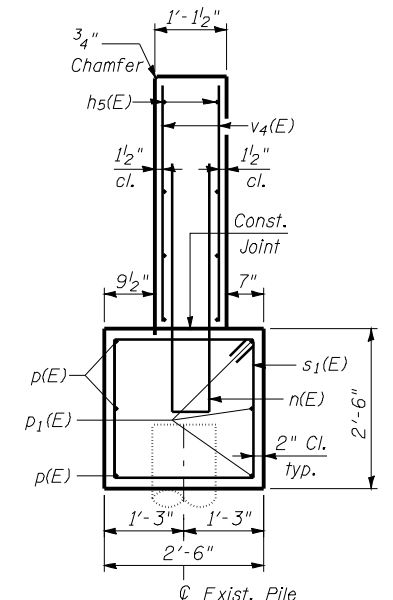

**SECTION C-C**

**ABUTMENT  
BILL OF MATERIAL**

Bar	No.	Size	Length	Shape
h(E)	10	#5	15'-1"	—
h1(E)	10	#5	18'-1"	—
h2(E)	5	#6	16'-3"	—
h3(E)	5	#6	19'-3"	—
h4(E)	20	#5	7'-0"	—
h5(E)	16	#4	11'-3"	—
n(E)	24	#6	9'-1"	—
p(E)	6	#7	11'-2"	—
p1(E)	6	#7	11'-5"	—
s(E)	35	#4	4'-8"	—
s1(E)	22	#4	9'-5"	—
s2(E)	4	#4	8'-3"	—
v(E)	35	#5	4'-3"	—
v1(E)	35	#5	3'-0"	—
v2(E)	37	#4	3'-1"	—
v3(E)	37	#5	1'-9"	—
v4(E)	48	#6	3'-5"	—
Structure Excavation		Cu. Yd.	52.5	
Concrete Structures		Cu. Yd.	18.0	
Reinforcement Bars, Epoxy Coated		Pound	2410	
Concrete Sealer		Sq. Ft.	174	

For details of Bar Splicers, see sheet 20 of 20.

**SOUTH ABUTMENT  
STRUCTURE NO. 085-0001**

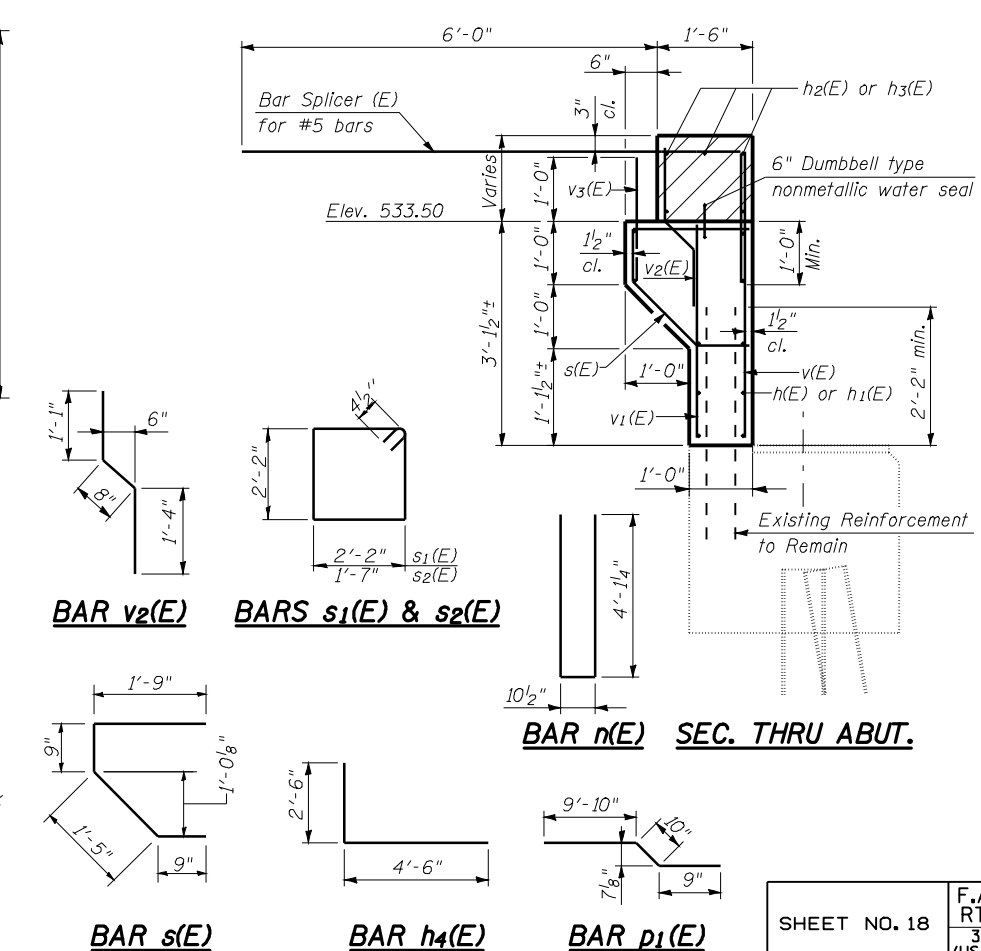

**BAR v2(E)**

**BARS s1(E) & s2(E)**

**BAR n(E) SEC. THRU ABUT.**

**BAR s(E)**

**BAR h4(E)**

**BAR p1(E)**

DESIGNED	CMW
CHECKED	JSA
DRAWN	TJW
CHECKED	CMW

**HOELSCHER ENGINEERING**

11 Executive Drive Suite 12  
Fairview Heights, Illinois 62208  
(618) 624-8610  
(618) 624-8611 (fax)

2501 Chatham Road, Suite 120  
Springfield, Illinois 62704  
(217) 698-8610  
(217) 698-8608 (fax)

115 North Neil Street, Suite 105  
Champaign, Illinois 61820  
(217) 351-8610  
(217) 351-8611 (fax)

Notes:  
Hatched area to be poured after superstructure formwork has been removed. Quantity of Concrete Included with Concrete Superstructure.  
I.F.= Inside Face  
O.F.= Outside Face

SHEET NO. 18	F.A. RTE. 310 (US 67)	SECTION (87B) BR	COUNTY SCHUYLER	TOTAL SHEETS 80	SHEET NO. 59
20 SHEETS	FED. ROAD DIST. NO.		ILLINOIS FED. AID PROJECT		
CONTRACT NO. 72B95					