

**BRIDGE APPROACH PAVEMENT CONNECTOR (PCC)**

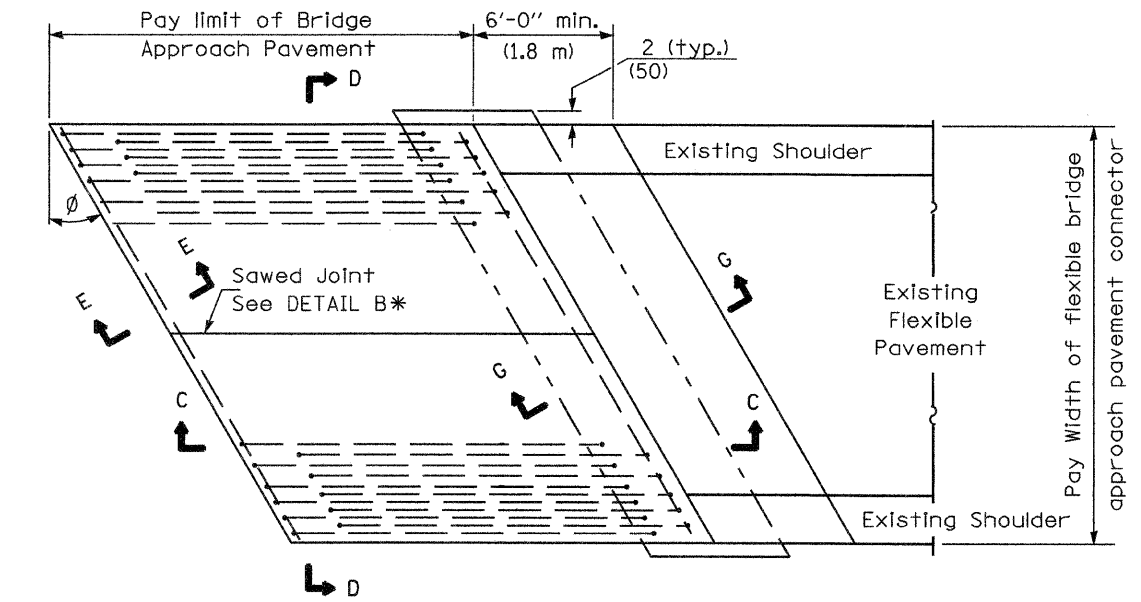

**BRIDGE APPROACH PAVEMENT CONNECTOR (FLEXIBLE)**

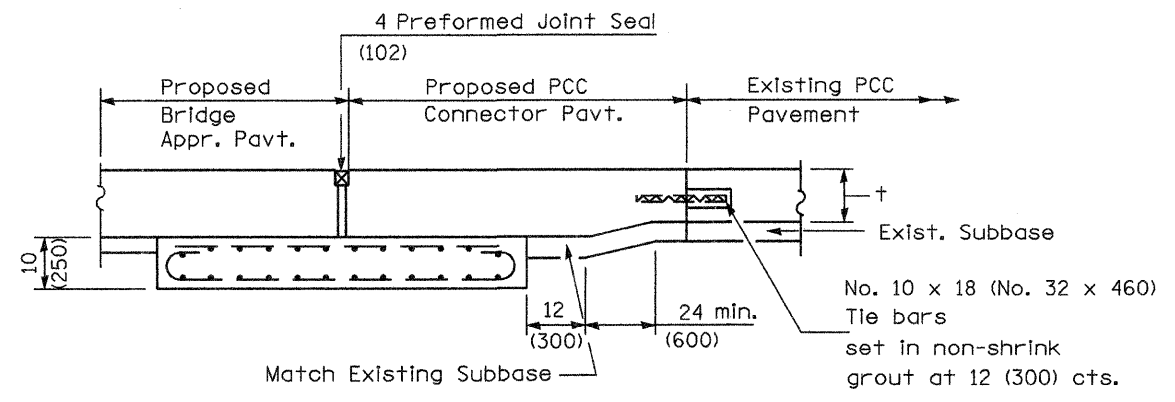

**SECTION G-G - RIGID PAVEMENT**

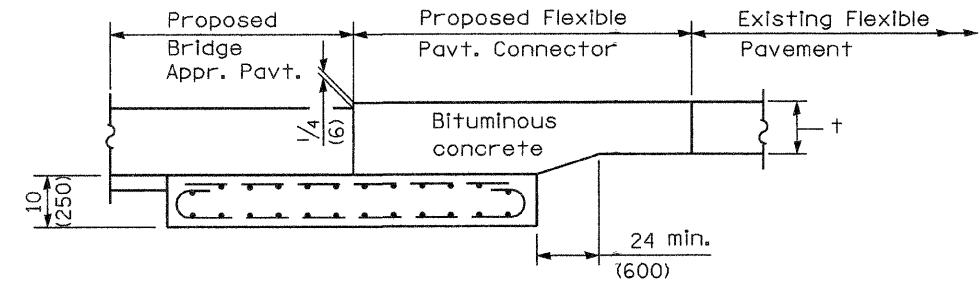

**SECTION G-G - FLEXIBLE PAVEMENT**

Illinois Department of Transportation  
 APPROVED January 1, 2008  
*Walsh E. Anderson*  
 ENGINEER OF BRIDGES AND STRUCTURES  
 APPROVED January 1, 2008  
*Ken E. Han*  
 ENGINEER OF DESIGN AND ENVIRONMENT  
 ISSUED 1-1-97

**BRIDGE APPROACH PAVEMENT**  
 (Sheet 2 of 4)  
 TOTAL SHEETS 65 SHEET NO. 44B

*DR. S. J. L.*