

| F.A.P. RTE. | SECTION | COUNTY | TOTAL SHEETS | SHEET NO. |
|-----------------------|---------|---------------|--------------|------------------|
| 876 | 9Y-RS-7 | WILL | 100 | 8 |
| STA. 1+700 | | TO STA. 2+500 | | |
| FED. ROAD DIST. NO. 1 | | ILLINOIS | | FED. AID PROJECT |

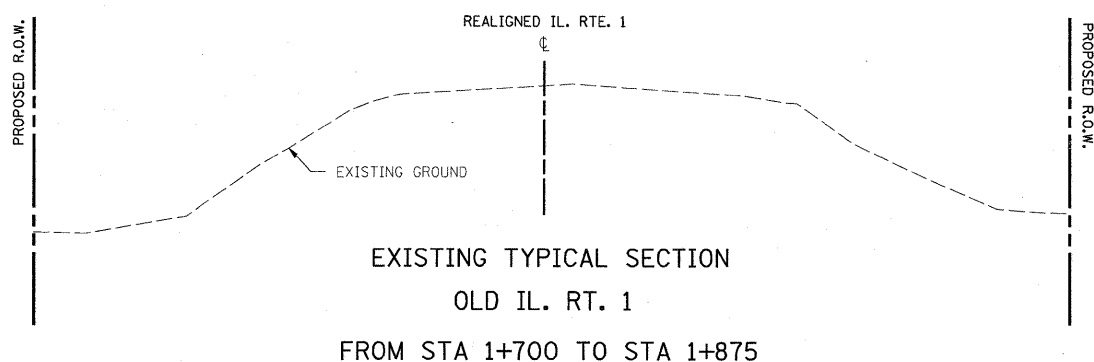

EXISTING TYPICAL SECTION
OLD IL. RT. 1
FROM STA 1+700 TO STA 1+875

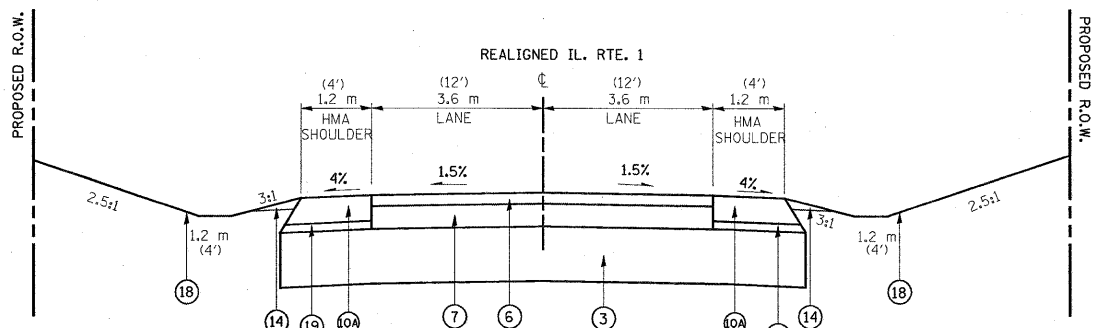

PROPOSED TYPICAL SECTION
REALIGNED OLD IL. RT. 1
FROM STA 1+700 TO STA 1+875

LEGEND:

- | | |
|--|---|
| ① EXIST. PCC PAVEMENT, 140 mm (5.5") | ⑬ PROP. STEEL PLATE BEAM GUARDRAIL, TYPE A |
| ①A EXIST. PCC PAVEMENT, 230 mm (9") | ⑭ PROP. AGGREGATE WEDGE, TYPE B |
| ② EXIST. HMA OVERLAY, 127 mm (5") | ⑮ PROP. HMA SURFACE REMOVAL, 60 mm (2.25") |
| ②A EXIST. HMA OVERLAY, 65 mm (2.5") | ⑯ PROP. PAVED SHOULDER REMOVAL |
| ③ PROP. AGGREGATE SUBGRADE, 300 mm (12") | ⑰ PROP. PAVEMENT REMOVAL |
| ④ PROP. HMA BINDER CSE., IL-19, N70, 200 mm (8") | ⑱ PROP. TOPSOIL FURNISH & PLACE, 100 mm (FORESLOPE) |
| ⑤ PROP. HMA SURF. CSE., MIX "D", N70, 50 mm (2") | SEEDING CLASS 2a |
| ⑥ PROP. POLYMERIZED HMA SURF. CSE., MIX "F", N90, 50 mm (2") | COMPOSIT FURNISH & PLACE 100 mm (BACKSLOPE) |
| ⑦ PROP. POLYMERIZED HMA BINDER CSE., 340 mm (13.5") | SEEDING CLASS 4 |
| ⑧ PROP. HMA SURF. CSE., MIX "D", N70, 38 mm (1.5") | EROSION CONTROL PLANKET |
| ⑨ PROP. LEVELING BINDER (MM), IL-19, N70, 19 mm (0.75") | |
| ⑩ PROP. HMA SHOULDERS, 250 mm (10") | |
| ⑩A PROP. HMA SHOULDERS, 280 mm (11") | |
| ⑪ PROP. AGGREGATE SHOULDER TYPE B, 150 mm (6") | |
| ⑫ PROP. HMA SURFACE REMOVAL, 50 mm (2") | |

NOTE:

▪ ILL. RTE. 1 STATION INCREASES FROM NORTH TO SOUTH

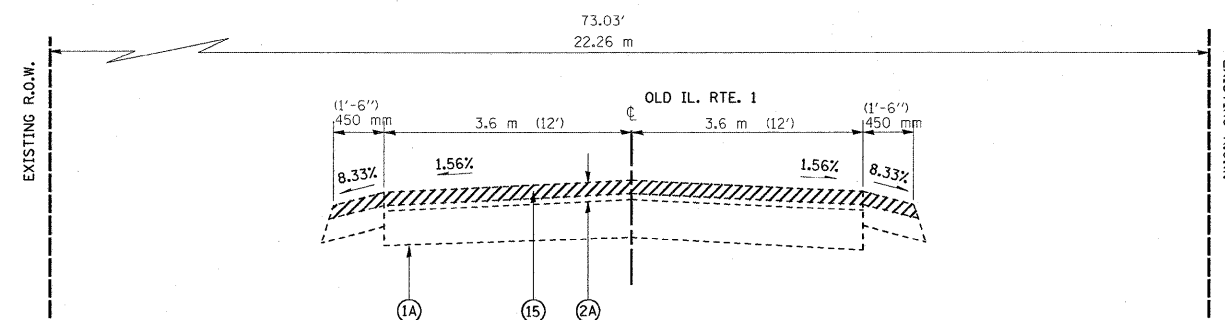

EXISTING TYPICAL SECTION
OLD IL. RT. 1
FROM STA 1+875 TO STA 2+500

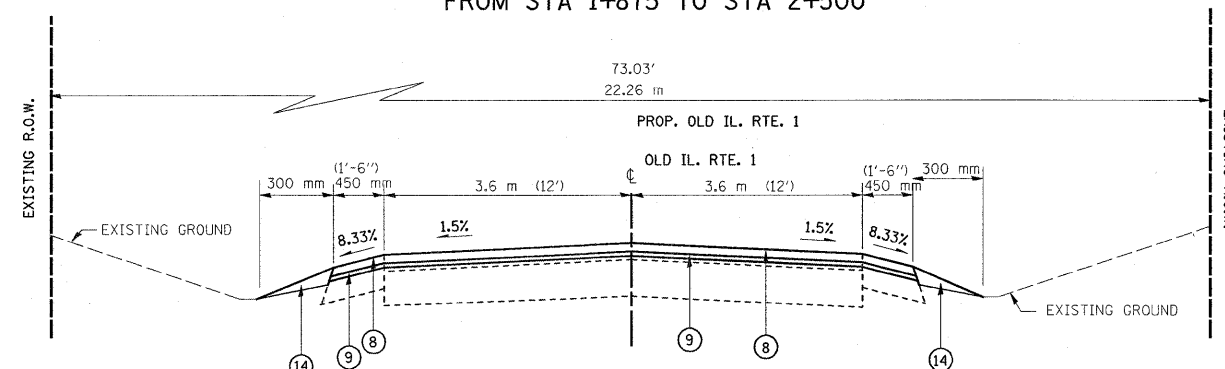

PROPOSED TYPICAL SECTION
FOR OLD IL. RT. 1
FROM STA 1+875 TO STA 2+500

| REVISIONS | | ILLINOIS DEPARTMENT OF TRANSPORTATION ILL. RTE. 1 EXISTING AND PROPOSED TYPICAL SECTIONS |
|-----------|------|---|
| NAME | DATE | |
| | | |
| | | |
| | | |
| | | |
| | | |
| | | |
| | | |
| | | |
| | | |
| | | |

SCALE: NONE DRAWN BY C.F.
DATE: 9/4/2008 CHECKED BY R.K.