

STATE OF ILLINOIS
DEPARTMENT OF TRANSPORTATION

ROUTE NO.	SECTION	COUNTY	TOTAL SHEETS	SHEET NO.	SHEET NO. 19 24 SHEETS
FAP 326	119BR-2	GRUNDY	52	35	
FED. ROAD DIST. NO. 7		ILLINOIS	FED. AID PROJECT-		

Contract #66688

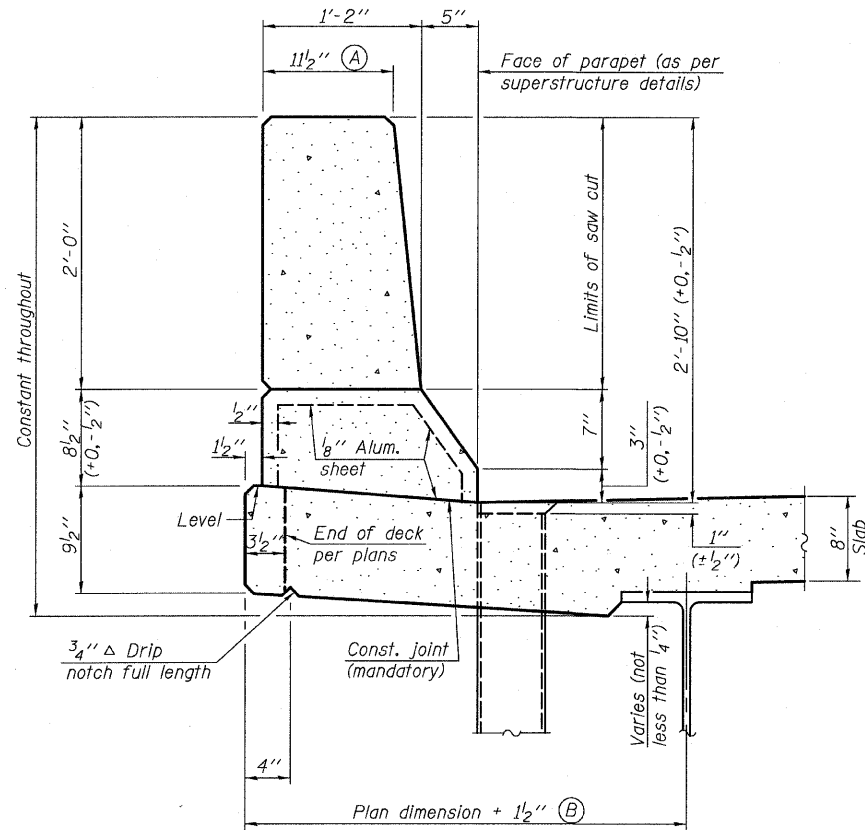

SECTION
(Showing dimensions)

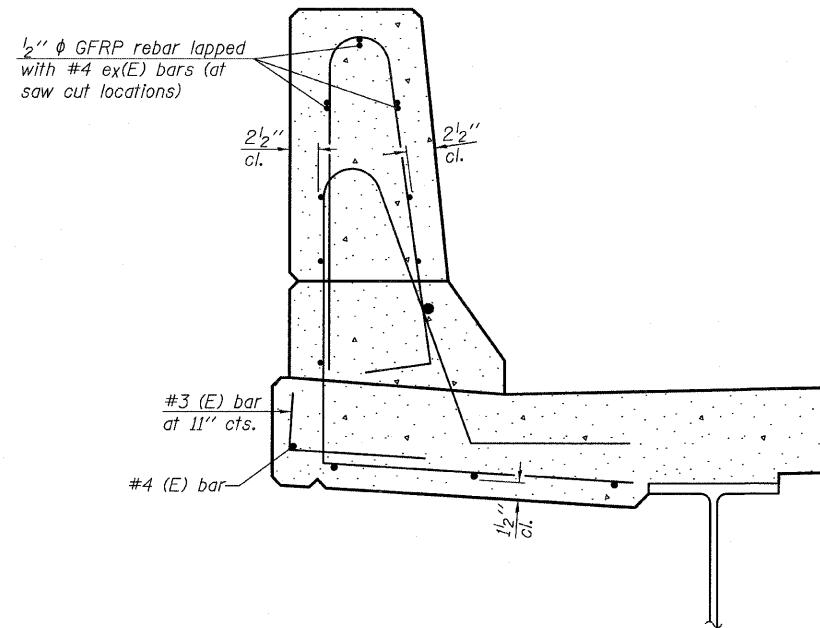

SECTION
(Showing reinforcement clearances for slip forming and additional reinforcement bars)

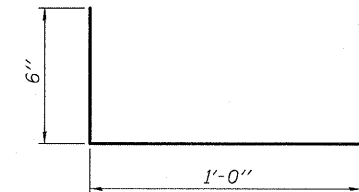

#3 (E) BAR

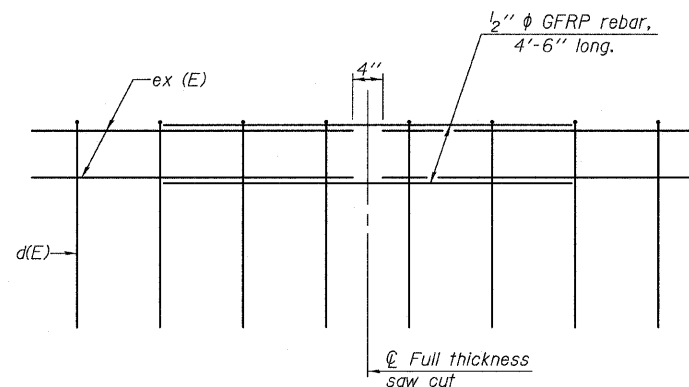

GFRP REBAR STIFFENING DETAIL
(Place as shown in parapet section at each parapet joint location.)

CONCRETE PARAPET SLIPFORMING OPTION
IL 47 OVER WEST FORK MAZON RIVER
FAP ROUTE 326 - SECTION 119BR-2
GRUNDY COUNTY
STATION 466+07.00
STRUCTURE NO. 032-0116



Eastport Business Center 1
100 Lanter Court, Suite 1
Collinsville, Illinois 62234
618-345-2200
Design Firm License No. 184.001115