

F.A.I. RTE.	SECTION	COUNTY	TOTAL SHEETS	SHEET NO.
57	*	DOUGLAS	76	1

*(15,21-25,21-26,27)RS-1

D-95-013-05

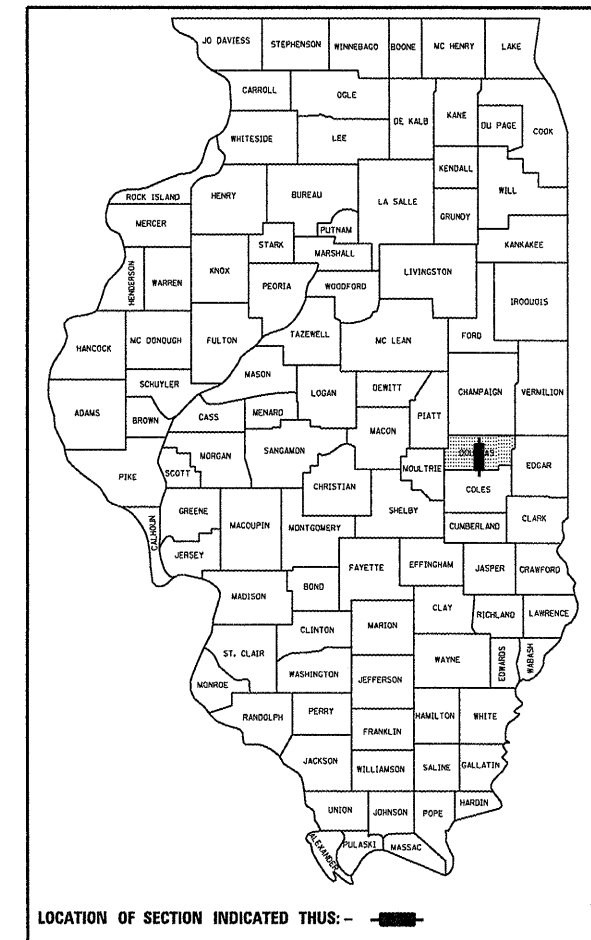

LOCATION OF SECTION INDICATED THUS: - [black rectangle] -

STATE OF ILLINOIS
DEPARTMENT OF TRANSPORTATION
DIVISION OF HIGHWAYS
PROPOSED
HIGHWAY PLANS
F.A.I. ROUTE 57
SECTION (15,21-25,21-26,27)RS-1
DOUGLAS COUNTY

C-95-014-05
RESURFACING /PATCHING FROM COLES CO. LINE TO 0.3 MI. NORTH OF US 36
PROJECT ACIM-057-5(193)205

FOR INDEX OF SHEETS, SEE SHEET NO. 2
 FOR SUMMARY OF QUANTITIES, SEE SHEET NO. 5 - 8

CURRENT TRAFFIC DATA

ADT = 18,000 (2007) I-57 SOUTH OF IL 133
 ADT = 19,000 (2007) I-57 NORTH OF IL 133
 ADT = 20,500 (2007) I-57 NORTH OF US 36

DESIGN DESIGNATION

INTERSTATE

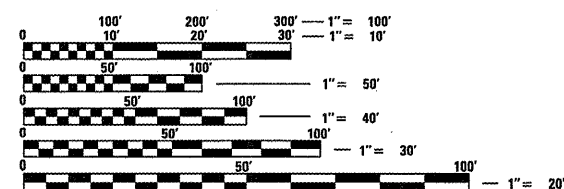

FULL SIZE PLANS HAVE BEEN PREPARED USING STANDARD ENGINEERING SCALES. REDUCED SIZED PLANS WILL NOT CONFORM TO STANDARD SCALES. IN MAKING MEASUREMENTS ON REDUCED PLANS, THE ABOVE SCALES MAY BE USED.

J.U.L.I.E.
 JOINT UTILITY LOCATION INFORMATION FOR EXCAVATION
 1-800-892-0123
 OR 811

PROJECT ENGINEER: NANCY FASIG
SQUAD LEADER: CORY SHEEHY
DESIGNER: KARY DAWSON
PHONE: (217)465-4181

CONTRACT NO. 70465

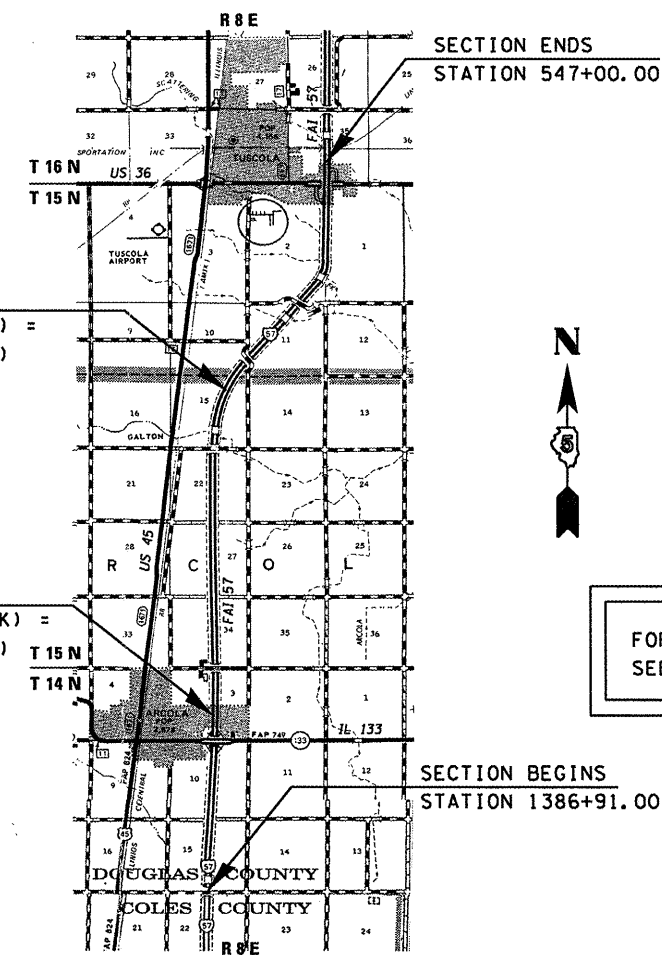

SECTION ENDS
 STATION 547+00.00

STATION EQUATION:
 STA 360+83.33 (BK) =
 STA 360+87.35 (AH)

STATION EQUATION:
 STA 1510+00.00 (BK) =
 STA 117+23.47 (AH)

SECTION BEGINS
 STATION 1386+91.00



FOR STRUCTURE LOCATIONS
SEE SHEET NO. 3

TOTAL LENGTH OF SECTION & PROJECT = 55,281.51 FEET = 10.470 MILES
 NET LENGTH OF SECTION & PROJECT = 54,489.96 FEET = 10.320 MILES

STATE OF ILLINOIS
 DEPARTMENT OF TRANSPORTATION
 DIVISION OF HIGHWAYS

SUBMITTED 8/21 20 08
Joseph E. Womack
 DEPUTY DIRECTOR OF HIGHWAYS, REGION THREE ENGINEER
October 3, 20 08
Eric E. Harn
 ENGINEER OF DESIGN AND ENVIRONMENT
October 3, 20 08
Christine M. Reed
 DIRECTOR OF HIGHWAYS, CHIEF ENGINEER

PRINTED BY THE AUTHORITY
OF THE STATE OF ILLINOIS

PLOT DATE = 8/21/2008
 PLOT SCALE = 1/4" = 100'
 PLOT SCALE = 1/8" = 50'
 PLOT SCALE = 1/16" = 25'
 USER NAME = abashygn

INDEX OF SHEETS

SHEET NO.	DESCRIPTION
1	COVER SHEET
2	INDEX OF SHEETS/HIGHWAY STANDARDS
3	LOCATION MAP SHOWING STRUCTURES
4	GENERAL NOTES
5 - 8	SUMMARY OF QUANTITIES
9 - 11	EXISTING TYPICAL CROSS SECTIONS
12 - 15	PROPOSED TYPICAL CROSS SECTIONS
16 - 26	SCHEDULE OF QUANTITIES
27 - 46	PLAN SHEETS
47 - 51	REPAIR PLANS FOR S.N. 021-0001
52 - 54	REPAIR PLANS FOR S.N. 021-0005 & 021-0006
55 - 56	REPAIR PLANS FOR S.N. 020-0008
57	DETAIL OF I-57 / IL 133 INTERCHANGE
58	DETAIL OF I-57 / US 36 INTERCHANGE
59 - 65	DETAIL OF BUTT JOINTS AND TRANSITIONS
66 - 67	DETAIL OF MEDIAN X-OVERS TO BE RECONSTRUCTED
68	DETAIL OF DELINEATORS
69	DETAIL OF CONCRETE MEDIAN, TYPE SM-6 (DOWELED)
70	DETAIL OF PARTIAL DEPTH PATCHING
71	DETAIL OF TRAFFIC CONTROL FOR RAMPS
72	DETAIL OF PAVEMENT MARKING (INTERSTATE & MULTI-LANE APPLICATIONS)
73 - 76	DETAIL OF PAVEMENT MARKING (RURAL & URBAN APPLICATIONS)

HIGHWAY STANDARDS

STANDARD NO.	DESCRIPTION
000001-05	STANDARD SYMBOLS, ABBREVIATIONS, AND PATTERNS
001001-01	AREAS OF REINFORCEMENT BARS
001006	DECIMAL OF AN INCH AND OF A FOOT
280001-04	TEMPORARY EROSION CONTROL SYSTEMS
420001-07	PAVEMENT JOINTS
442001-04	CLASS A PATCHES
482011-03	HMA SHOULDER STRIPS/SHOULDERS WITH RESURFACING OR WIDENING AND RESURFACING PROJECTS
606301-03	PC CONCRETE ISLANDS AND MEDIANS
635001	DELINEATORS
635006-02	REFLECTOR AND TERMINAL MARKER PLACEMENT
635011-01	REFLECTOR MARKER AND MOUNTING DETAILS
642001	SHOULDER RUMBLE STRIPS
701101-01	OFF-ROAD OPERATIONS, MULTILANE, 4.5 M (15") TO 600 MM (24") FROM PAVEMENT EDGE
701400-02	APPROACH TO LANE CLOSURE, FREEWAY/ EXPRESSWAY
701401-04	LANE CLOSURE, FREEWAY/ EXPRESSWAY
701402-06	LANE CLOSURE, FREEWAY/ EXPRESSWAY WITH BARRIER
701406-04	LANE CLOSURE, FREEWAY/ EXPRESSWAY, DAY OPERATIONS ONLY
701411-04	LANE CLOSURE, MULTILANE, AT ENTRANCE OR EXIT RAMP, FOR SPEEDS ≥ 45 MPH
701426-02	LANE CLOSURE, MULTILANE, INTERMITTENT OR MOVING OPER., FOR SPEEDS ≥ 45 MPH
701901	TRAFFIC CONTROL DEVICES
704001-04	TEMPORARY CONCRETE BARRIER
720011	METAL POSTS FOR SIGNS, MARKERS & DELINEATORS
780001-01	TYPICAL PAVEMENT MARKINGS
781001-02	TYPICAL APPLICATION OF RAISED REFLECTIVE PAVEMENT MARKERS
886001	DETECTOR LOOP INSTALLATIONS
886006	TYPICAL LAYOUT FOR DETECTOR LOOPS

CONTRACT NO. 70465				
F.A.I. RTE.	SECTION	COUNTY	TOTAL SHEETS	SHEET NO.
57	*	DOUGLAS	76	2

* (15,21-25,21-26,27)RS-1

PLOT DATE = 08/21/2008
 FILE NAME = c:\projects\70465\70465cover.dgn
 PLOT SCALE = 1/8"=1'-0" / IN.
 USER NAME = ahsealgun

ILLINOIS DEPARTMENT OF TRANSPORTATION
INDEX OF SHEETS AND
HIGHWAY STANDARDS
 F.A.I. ROUTE 57
 SECTION (15,21-25,21-26,27)RS-1
 DOUGLAS COUNTY

SCALE: N/A
 DATE: 08-2008

DRAWN BY: RC
 CHECKED BY: KD

F.A.I. RTE.	SECTION	COUNTY	TOTAL SHEETS	SHEET NO.
57	*	DOUGLAS	76	3

*(15,21-25,21-26,27)RS-1

LOCATION MAP SHOWING STRUCTURES

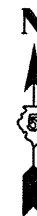
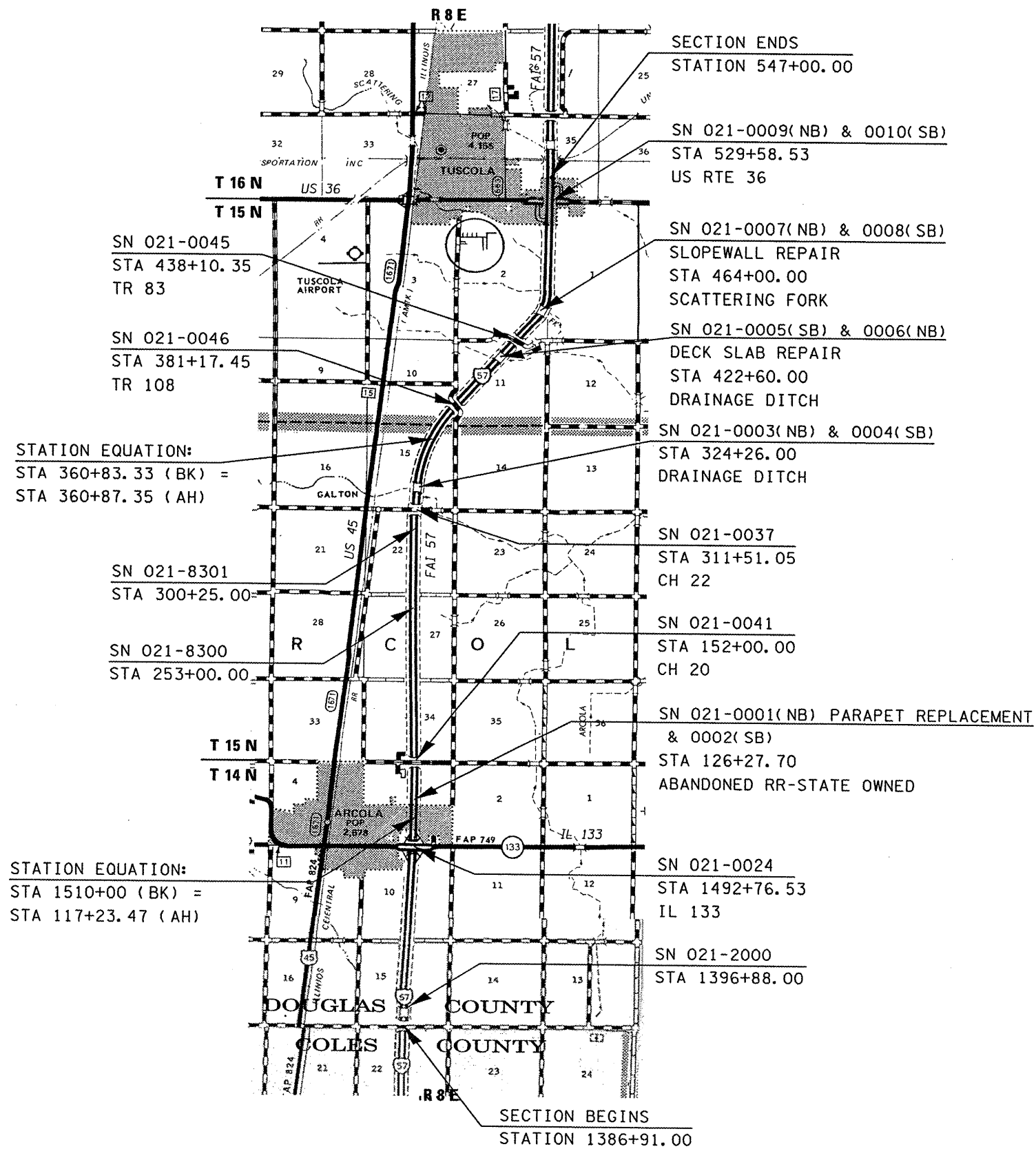

PLOT DATE = 9/1/2008
FILE NAME = c:\projects\70465\cover.dgn
PLOT SCALE = 1/8"=1'-0"
USER NAME = gregory.k

ILLINOIS DEPARTMENT OF TRANSPORTATION
LOCATION MAP
SHOWING STRUCTURES
F.A.I. ROUTE 57
SECTION (15,21-25,21-26,27)RS-1
DOUGLAS COUNTY

SCALE: DO NOT SCALE
DATE: 08-08-08
DRAWN BY: JP
CHECKED BY: KD

F.A.I. RTE.	SECTION	COUNTY	TOTAL SHEETS	SHEET NO.
57	*	DOUGLAS	76	4

* (15,21-25,21-26,27)RS-1

GENERAL NOTES

G.N.-100

ENGLISH UNITS OF MEASUREMENT SHALL GOVERN OVER AND SUPERSEDE ANY METRIC UNITS SHOWN IN THIS CONTRACT. WHERE INCLUDED, METRIC UNITS ARE FOR INFORMATION ONLY.

G.N.-105.07B

EXISTING STATE-OWNED AND MAINTAINED UTILITY LINES ARE SHOWN ON THE PLANS TO INDICATE THEIR PRESENCE AND APPROXIMATE LOCATION. THE CONTRACTOR SHALL SECURE AN APPROVED LOCATING FIRM TO LOCATE STATE-OWNED UTILITIES PRIOR TO COMMENCING ANY EXCAVATION IN THE VICINITY OF THESE LINES IN ACCORDANCE TO SECTION 803 OF THE STANDARD SPECIFICATIONS. SHOULD ANY OF THE LINES BE DAMAGED BY THE CONTRACTOR'S OPERATION, THE CONTRACTOR SHALL REPAIR THEM TO THE SATISFACTION OF THE ENGINEER AT NO COST TO THE STATE.

ALSO THERE MAY BE UTILITIES PRESENT WHICH WERE INSTALLED BY THE STATE BUT ARE MAINTAINED BY OTHERS (CITY, TOWN, ETC.) THE APPROXIMATE LOCATIONS OF THESE LINES ARE ALSO SHOWN ON THE PLANS ALONG WITH THE NAME OF THE MAINTAINING AGENCY. THE CONTRACTOR SHALL COORDINATE THE LOCATION OF THESE LINES WITH THE LOCAL AGENCY PRIOR TO COMMENCING ANY EXCAVATION OR BORING IN THEIR VICINITY. SHOULD THESE LINES BE DAMAGED BY THE CONTRACTOR'S OPERATIONS, THE CONTRACTOR SHALL REPAIR THEM TO THE SATISFACTION OF, AND AT NO COST TO, THE LOCAL AGENCY AND THE STATE.

G.N.-107.31

UTILITY LINES WERE PLOTTED FROM INFORMATION FURNISHED BY THE VARIOUS UTILITY COMPANIES INVOLVED (QUALITY LEVEL C &/OR QUALITY LEVEL D) AND THE ACCURACY SHOULD BE CONSIDERED APPROXIMATE ONLY.

UTILITY COMPANIES MAY BE ADJUSTING THEIR FACILITIES DURING CONSTRUCTION. THE CONTRACTOR SHALL COOPERATE WITH THESE ORGANIZATIONS WHILE THESE ADJUSTMENTS ARE BEING PERFORMED. J.U.L.I.E. - JOINT UTILITY LOCATION INFORMATION FOR EXCAVATORS SYSTEM (800)892-0123 OR 811.

G.N.-250C

SEEDING, CLASS 7 AND MULCH, METHOD 2 IS INCLUDED IN THIS CONTRACT TO SEED NEW EARTH SHOULDERS DURING TIME PERIODS WHEN PERMANENT SEEDING IS NOT ALLOWED. SOME OR ALL OF THE CLASS 7 SEEDING AND MULCH WILL BE DELETED IF IT IS POSSIBLE TO PLACE PERMANENT SEEDING ON EARTH SHOULDERS AT THE TIME OF THEIR COMPLETION.

G.N.-406

THE QUANTITIES INCLUDED IN THE PLANS FOR HOT-MIX ASPHALT RESURFACING ARE INTENDED TO GIVE THE COVERAGE SHOWN ON THE TYPICAL CROSS SECTIONS. IT IS NOT INTENDED TO INCREASE THE THICKNESS OF THE HOT-MIX ASPHALT MIXTURE IN ORDER TO USE ALL OF THE QUANTITIES INCLUDED IN THE CONTRACT.

G.N.-406.05b

ALL LEVELING BINDER OR BINDER SHALL BE GIVEN A FOG COAT OF PRIME BEFORE THE SURFACE COURSE IS PLACED WHEN DIRECTED BY THE ENGINEER.

THE FOG COAT WILL BE PAID FOR AT THE CONTRACT UNIT PRICE PER GALLON FOR BITUMINOUS MATERIAL (PRIME COAT) AND NO ADDITIONAL COMPENSATION WILL BE ALLOWED.

G.N.-406.10

FOR MULTILANE RESURFACING

WHEN BEGINNING THE RESURFACING WITH NEW MIXTURES FOR LEVELING BINDER, BINDER COURSE, AND SURFACE COURSE MIXTURES, THE WORK WILL BE CONFINED TO THE INSIDE TRAFFIC LANE (PASSING LANE) FIRST. THE WORK WILL REMAIN ON THE INSIDE LANE UNTIL THE MIX HAS BEEN ADJUSTED AND APPROVED BY THE ENGINEER BEFORE ANY RESURFACING IS ALLOWED ON THE OUTSIDE (DRIVING) TRAFFIC LANE(S).

ANY DELAYS OR INCONVENIENCES CAUSED THE CONTRACTOR IN COMPLYING WITH THIS REQUIREMENT WILL BE CONSIDERED INCIDENTAL TO THE VARIOUS HOT-MIX ASPHALT PAY ITEMS, AS SHOWN IN THE CONTRACT, AND NO ADDITIONAL COMPENSATION WILL BE ALLOWED.

G.N. -406H

MIXTURE REQUIREMENTS

The following mixture requirements are applicable for this project:

Location(s):	I-57	I-57
Mixture Use(s):	Polymer Surface	Polymer Binder
AC/PG:	SBS PG 70-22	SBS PG 70-22
RAP %: (Max)**	10	10
Design Air Voids:	4.0% Ndes=105	4.0% Ndes=105
Mixture Composition: (Gradation Mixture)	IL 9.5	IL 19.0
Friction Aggregate:	Mix D	N.A.

Location(s):	I-57	I-57
Mixture Use(s):	Polymer Level Binder	HMA Shoulders
AC/PG:	SBS PG 70-22	PG 58-22
RAP %: (Max)**	10	30
Design Air Voids:	4.0% Ndes=105	4.0% Ndes=30
Mixture Composition: (Gradation Mixture)	IL 9.5	IL 9.5L
Friction Aggregate:	Mix C	Mix C

Location(s):	Crossovers	HMA Shoulders (Spec)
Mixture Use(s):	Incidental	Partial Depth Patch
AC/PG:	PG 64-22	PG 64-22
RAP %: (Max)**	15	10
Design Air Voids:	4.0% Ndes=50	4.0% Ndes=105
Mixture Composition: (Gradation Mixture)	IL 9.5	IL 19.0
Friction Aggregate:	Mix C	N.A.

G.N.-408B

THE INCIDENTAL HOT-MIX ASPHALT SURFACING SHALL BE COMPACTED AS REQUIRED BY THE SPECIFICATIONS FOR DESIGN NUMBER OF GYRATIONS BEING USED,

AT THE FOLLOWING LOCATIONS:

MEDIAN CROSSOVERS AT

- 1431+00
- 142+80
- 293+93
- 478+54

G.N.-440A (SPL)

THE HOT-MIX ASPHALT SURFACE REMOVAL (COLD MILLING) ON THIS JOB IS INTENDED TO TRUE UP THE EXISTING PAVEMENT SURFACE IN THE PASSING LANES WHICH ARE TO BE OVERLAID WITH SURFACE ONLY. BECAUSE THIS OPERATION REQUIRES CAREFUL JUDGMENT TO ACHIEVE THE DESIRED RESULT AND AVOID EXCESSIVE REMOVAL, THE DISTRICT HAS PREPARED A VIDEOTAPE TO ILLUSTRATE THE DESIRED OPERATION.

THIS VIDEOTAPE IS AVAILABLE FOR REVIEW IF THE CONTRACTOR IS NOT FAMILIAR WITH THE DISTRICT'S INTENT.

G.N.-442B - PATCHING SCHEDULES

THE PATCHING SCHEDULES INCLUDED IN THE PLANS REPRESENT THE BEST INFORMATION AVAILABLE AT THE TIME OF COMPLETION OF THE PLANS FOR LETTING. VARIATIONS IN LOCATION AND SIZES OF BOTH FULL-DEPTH AND PARTIAL-DEPTH PATCHES MAY OCCUR.

G.N.-482

ALL MATERIAL PLACED AS HOT-MIX ASPHALT SHOULDERS SHALL BE COMPACTED TO 94.0 - 98.4 PERCENT OF THE MAXIMUM THEORETICAL DENSITY. THIS REQUIREMENT SHALL APPLY TO IL 9.5L GRADATION SHOULDER MIXES AND OTHER MIXES (BOTTOM LIFT OF SHOULDERS). THIS MAXIMUM DENSITY SHALL BE DETERMINED FROM THE MOVING AVERAGE OF FOUR TESTS AS IN OTHER QC/QA TESTING. A NUCLEAR GAUGE DENSITY/CORE CORRELATION SHALL BE PERFORMED FOR THE IL 9.5L MIXES AND OTHER MIXES USING STANDARD CORRELATION PROCEDURES.

G.N.-703A

SHORT TERM PAVEMENT MARKING SHALL BE APPLIED TO THE PAVEMENT AFTER ANY OF THE FOLLOWING: COLD MILLING AND/OR PLACING BITUMINOUS MATERIALS (PRIME COAT), LEVELING BINDER (MACHINE METHOD), BINDER AND SURFACE COURSES. SHORT TERM PAVEMENT MARKING PLACED ON THE SURFACE, SHALL COINCIDE WITH THE FINAL PAVEMENT STRIPING. SHORT TERM PAVEMENT MARKING PLACED PRIOR TO THE SURFACE SHALL COINCIDE WITH THE EXISTING PAVEMENT MARKINGS. USE 4 FEET PER 40 FEET (OR 10% PER STATION).

G.N.-781

RAISED REFLECTIVE PAVEMENT MARKERS SHALL BE PLACED IN ACCORDANCE WITH STANDARD 781001, AND THE DETAILS SHOWN IN THE PLANS. IF THERE IS ANY DISCREPANCY BETWEEN THE STANDARD AND THE DETAILS IN THE PLANS, THE DETAILS IN THE PLANS SHALL GOVERN. THE FINAL PAVEMENT MARKINGS SHALL BE IN PLACE PRIOR TO PLACING THE RAISED REFLECTIVE PAVEMENT MARKERS AND THE RAISED REFLECTIVE PAVEMENT MARKERS SHALL BE PLACED MIDWAY IN THE 30 FOOT (9 m) SPACE BETWEEN THE DASHED CENTERLINE STRIPES (WHEN APPLICABLE).

G.N. - 873

EXISTING DETECTOR LOOPS IN THE AREAS OF PROPOSED SURFACE REMOVAL SHALL BE REPLACED PER THE EXISTING SIZE AND LOCATION EXCEPT AS NOTED IN THE PLANS. EXISTING DETECTOR LOOPS SHALL BE DISCONNECTED AT THE GULFBOX JUNCTION OR HANDHOLE PRIOR TO COLD MILLING AT THAT RESPECTIVE LOCATION. NEW DETECTOR LOOPS SHALL BE CONNECTED TO THE RESPECTIVE EXISTING AMPLIFIER. IN GENERAL, ADVANCED DETECTOR LOOPS FOR DILEMMA ZONE PROTECTION LOCATED AT THE SAME STATION SHALL BE GROUPED TOGETHER ON A COMMON AMPLIFIER. PRESENCE LOOPS SHALL BE GROUPED BY LANE ON A COMMON AMPLIFIER.

WHERE IT IS NECESSARY TO INSTALL MORE THAN ONE LOOP HOMERUN IN A CONDUIT, HOMERUNS SHARING THE SAME CONDUIT SHALL BE ON A COMMON AMPLIFIER.

G.N.-1004.01

COARSE AGGREGATE GRADATION CA-10 MAY BE USED WHENEVER COARSE AGGREGATE CA-6 IS SPECIFIED IN THE STANDARD SPECIFICATIONS.

COMMITMENTS

NO COMMITMENTS ARE REQUIRED FOR THIS PROJECT.

ILLINOIS DEPARTMENT OF TRANSPORTATION

GENERAL NOTES

F.A.I. ROUTE 57
SECTION (15,21-25,21-26,27)RS-1
DOUGLAS COUNTY

SCALE: N/A
DATE: 08-2008

DRAWN BY: RC
CHECKED BY: KD

F.A.I. SECTION	COUNTY	TOTAL SHEETS	SHEET NO.
57 *	DOUGLAS	76	5

* (15,21-25,21-26,27)RS-1

SUMMARY OF QUANTITIES

LOCATION OF WORK:

I-57 DOUGLAS COUNTY	I-57 DOUGLAS COUNTY	I-57 DOUGLAS COUNTY	I-57 DOUGLAS COUNTY
Sta. 1386+91.00 to Sta. 547+00	SN 021-0001	SN 021-0005 & SN 021-0006	SN 021-0008
RURAL 90% FED 10% STATE	RURAL 90% FED 10% STATE	RURAL 90% FED 10% STATE	RURAL 90% FED 10% STATE
1000-2A	SFTY-2A	SFTY-2A	SFTY-2A

CONSTRUCTION TYPE CODE:

CODE NO.	DESCRIPTION	UNIT	TOTAL QUANTITY	I-57 DOUGLAS COUNTY	I-57 DOUGLAS COUNTY
20400800	FURNISHED EXCAVATION	CU YD	5,365.0	5,365.0	
25000210	SEEDING, CLASS 2A	ACRE	20.0	20.0	
25000350	SEEDING, CLASS 7	ACRE	20.0	20.0	
25000400	NITROGEN FERTILIZER NUTRIENT	POUND	1,800.0	1,800.0	
25000500	PHOSPHORUS FERTILIZER NUTRIENT	POUND	1,800.0	1,800.0	
25000600	POTASSIUM FERTILIZER NUTRIENT	POUND	1,800.0	1,800.0	
25100115	MULCH, METHOD 2	ACRE	20.0	20.0	
28000250	TEMPORARY EROSION CONTROL SEEDING	POUND	2,000.0	2,000.0	
28000300	TEMPORARY DITCH CHECKS	EACH	3.0	3.0	
28000500	INLET AND PIPE PROTECTION	EACH	3.0	3.0	
28100207	STONE RIPRAP, CLASS A4	TON	265.0		265.0
35101400	AGGREGATE BASE COURSE, TYPE B	TON	48.0	48.0	
35300505	PORTLAND CEMENT CONCRETE BASE COURSE 10 1/4"	SQ YD	179.0	179.0	
40600100	BITUMINOUS MATERIALS (PRIME COAT)	GALLON	58,590.0	58,590.0	
40600300	AGGREGATE (PRIME COAT)	TON	1,172.0	1,172.0	
40600855	POLYMERIZED LEVELING BINDER (MACHINEMETHOD), N105	TON	840.0	840.0	
40600895	CONSTRUCTING TEST STRIP	EACH	2.0	2.0	
40600982	HOT-MIX ASPHALT SURFACE REMOVAL - BUTTJOINT	SQ YD	18,783.0	18,783.0	
40600985	PORTLAND CEMENT CONCRETE SURFACE REMOVAL+ BUTT JOINT	SQ YD	720.0	720.0	
40600990	TEMPORARY RAMP	SQ YD	3,959.0	3,959.0	
40603245	POLYMERIZED HOT-MIX ASPHALT BINDER COURSE, IL-19.0, N105	TON	45,686.0	45,686.0	
40603550	POLYMERIZED HOT-MIX ASPHALT SURFACE COURSE, MIX "D", N105	TON	29,239.0	29,239.0	
40800010	BITUMINOUS MATERIALS (PRIME COAT)	GALLON	63.0	63.0	
40800030	AGGREGATE (PRIME COAT)	TON	2.0	2.0	
40800050	INCIDENTAL HOT-MIX ASPHALT SURFACING	TON	90.0	90.0	
44000155	HOT-MIX ASPHALT SURFACE REMOVAL, 1 1/2"	SQ YD	1,461.0	1,461.0	
44000162	HOT-MIX ASPHALT SURFACE REMOVAL, 3 1/4"	SQ YD	144,877.0	144,877.0	

* SPECIALTY ITEMS

SHEET 1 OF 4

ILLINOIS DEPARTMENT OF TRANSPORTATION
SUMMARY OF QUANTITIES
 F.A.I. ROUTE 57
 SECTION (15,21-25,21-26,27)RS-1
 DOUGLAS COUNTY

SCALE: N/A
 DATE: 08-12-08

DRAWN BY: JP
 CHECKED BY: KD

PLOT DATE = 8/21/2008
 FILE NAME = c:\projects\70465\70465.dgn
 PLOT SCALE = 1/8" = 1' IN.
 USER NAME = sheshaun

F.A.I. RTG.	SECTION	COUNTY	TOTAL SHEETS	SHEET NO.
57	*	DOUGLAS	76	6

* (15,21-25,21-26,27)RS-1

SUMMARY OF QUANTITIES

LOCATION OF WORK:	I-57	I-57	I-57	I-57
	DOUGLAS COUNTY	DOUGLAS COUNTY	DOUGLAS COUNTY	DOUGLAS COUNTY
	Sta. 1386+91.00 to Sta. 547+00	SN 021-0001	SN 021-0005 & SN 021-0006	SN 021-0008
	RURAL 90% FED 10% STATE	RURAL 90% FED 10% STATE	RURAL 90% FED 10% STATE	RURAL 90% FED 10% STATE
CONSTRUCTION TYPE CODE:	1000-2A	SFTY-2A	SFTY-2A	SFTY-2A

CODE NO.	DESCRIPTION	UNIT	TOTAL QUANTITY	
44000169	HOT-MIX ASPHALT SURFACE REMOVAL, 5"	SQ YD	17,374.0	17,374.0
44000198	HOT-MIX ASPHALT SURFACE REMOVAL, VARIABLE DEPTH	SQ YD	81,709.0	81,709.0
44001005	HOT-MIX ASPHALT SURFACE REMOVAL	SQ YD	270.0	270.0
44002805	ISLAND REMOVAL	SQ FT	1,612.0	1,612.0
44200523	CLASS A PATCHES, TYPE IV, 7 INCH	SQ YD	4,400.0	4,400.0
44200549	CLASS A PATCHES, TYPE I, 10 INCH	SQ YD	24.0	24.0
44200553	CLASS A PATCHES, TYPE II, 10 INCH	SQ YD	214.0	214.0
44200557	CLASS A PATCHES, TYPE III, 10 INCH	SQ YD	40.0	40.0
44200559	CLASS A PATCHES, TYPE IV, 10 INCH	SQ YD	27.0	27.0
44200573	CLASS A PATCHES, TYPE I, 12 INCH	SQ YD	20.0	20.0
44200577	CLASS A PATCHES, TYPE II, 12 INCH	SQ YD	55.0	55.0
44213000	PATCHING REINFORCEMENT	SQ YD	4,780.0	4,780.0
44213200	SAW CUTS	FOOT	16,032.0	16,032.0
44400100	FIBER GLASS FABRIC REPAIR SYSTEM	SQ YD	2,274.0	2,274.0
48101200	AGGREGATE SHOULDERS, TYPE B	TON	767.0	767.0
48203100	HOT-MIX ASPHALT SHOULDERS	TON	34,843.0	34,843.0
48203105	HOT-MIX ASPHALT SHOULDERS, SPECIAL	TON	660.0	660.0
50102400	CONCRETE REMOVAL	CU YD	15.9	15.9
50300255	CONCRETE SUPERSTRUCTURE	CU YD	15.9	15.9
50300300	PROTECTIVE COAT	SQ YD	58.0	58.0
50800205	REINFORCEMENT BARS, EPOXY COATED	POUND	2,590.0	2,590.0
60300105	FRAMES AND GRATES TO BE ADJUSTED	EACH	1.0	1.0
60622354	CONCRETE MEDIAN, TYPE SM-6 (DOWELLED)	SQ FT	1,645.0	1,645.0
* 63500105	DELINEATORS	EACH	234.0	234.0
63500120	DELINEATOR REMOVAL	EACH	234.0	234.0
64200105	SHOULDER RUMBLE STRIP	FOOT	211,477.0	211,477.0
67000500	ENGINEER'S FIELD OFFICE, TYPE B	CAL MO	9.0	9.0

* SPECIALTY ITEMS

SHEET 2 OF 4

ILLINOIS DEPARTMENT OF TRANSPORTATION
SUMMARY OF QUANTITIES
 F.A.I. ROUTE 57
 SECTION (15,21-25,21-26,27)RS-1
 DOUGLAS COUNTY

SCALE: N/A
 DATE: 08-12-08

DRAWN BY: JP
 CHECKED BY: KD

PLOT DATE = 8/21/2008
 FILE NAME = c:\pwork\mca\j201005\081208\70465cover.dgn
 PLOT SCALE = 1/8"=1'-0"
 USER NAME = ahahlgum

F.A.I. RTE.	SECTION	COUNTY	TOTAL SHEETS	SHEET NO.
57	*	DOUGLAS	76	7

* (15,21-25,21-26,27)RS-1

SUMMARY OF QUANTITIES

LOCATION OF WORK:	I-57	I-57	I-57	I-57
	DOUGLAS	DOUGLAS	DOUGLAS	DOUGLAS
	COUNTY	COUNTY	COUNTY	COUNTY
	Sta. 1386+91.00	SN 021-0001	SN 021-0005 &	SN 021-0008
	to Sta. 547+00		SN 021-0006	
	RURAL	RURAL	RURAL	RURAL
	90% FED	90% FED	90% FED	90% FED
	10% STATE	10% STATE	10% STATE	10% STATE
CONSTRUCTION TYPE CODE:	1000-2A	SFTY-2A	SFTY-2A	SFTY-2A

CODE NO.	DESCRIPTION	UNIT	TOTAL QUANTITY	
67100100	MOBILIZATION	L SUM	1.0	1.0
70100420	TRAFFIC CONTROL AND PROTECTION,STANDARD 701411	EACH	8.0	8.0
70100700	TRAFFIC CONTROL AND PROTECTION,STANDARD 701406	L SUM	1.0	1.0
70100800	TRAFFIC CONTROL AND PROTECTION,STANDARD 701401	L SUM	1.0	1.0
70100805	TRAFFIC CONTROL AND PROTECTION,STANDARD 701402	L SUM	1.0	1.0
70103815	TRAFFIC CONTROL SURVEILLANCE	CAL DA	57.0	57.0
70300100	SHORT-TERM PAVEMENT MARKING	FOOT	58,386.0	58,386.0
70300220	TEMPORARY PAVEMENT MARKING- LINE 4"	FOOT	267,181.0	267,181.0
70300240	TEMPORARY PAVEMENT MARKING- LINE 6"	FOOT	557.0	557.0
70300250	TEMPORARY PAVEMENT MARKING- LINE 8"	FOOT	6,350.0	6,350.0
70300260	TEMPORARY PAVEMENT MARKING- LINE 12"	FOOT	220.0	220.0
70300280	TEMPORARY PAVEMENT MARKING- LINE 24"	FOOT	145.0	145.0
70301000	WORK ZONE PAVEMENT MARKING REMOVAL	SQ FT	7,422.0	7,422.0
70400100	TEMPORARY CONCRETE BARRIER	FOOT	362.5	362.5
* 78000200	THERMOPLASTIC PAVEMENT MARKING- LINE 4"	FOOT	240,088.0	240,088.0
* 78000400	THERMOPLASTIC PAVEMENT MARKING- LINE 6"	FOOT	557.0	557.0
* 78000500	THERMOPLASTIC PAVEMENT MARKING- LINE 8"	FOOT	6,350.0	6,350.0
* 78000600	THERMOPLASTIC PAVEMENT MARKING- LINE 12"	FOOT	220.0	220.0
* 78000650	THERMOPLASTIC PAVEMENT MARKING- LINE 24"	FOOT	145.0	145.0
* 78003110	PREFORMED PLASTIC PAVEMENT MARKING,TYPE B - LINE 4"	FOOT	27,093.0	27,093.0
* 78008310	POLYUREA PAVEMENT MARKING TYPE II - LINE 4"	FOOT	4,596.0	4,596.0
* 78100100	RAISED REFLECTIVE PAVEMENT MARKER	EACH	1,633.0	1,633.0
78300100	PAVEMENT MARKING REMOVAL	SQ FT	175.0	175.0
78300200	RAISED REFLECTIVE PAVEMENT MARKER REMOVAL	EACH	1,880.0	1,880.0
81400115	HANDHOLE TO BE ADJUSTED	EACH	1.0	1.0
* 88600100	DETECTOR LOOP, TYPE I	FOOT	170.0	170.0
* X0301741	AERIAL SPEED CHECK MARKING	FOOT	72.0	72.0

* SPECIALTY ITEMS

SHEET 3 OF 4

ILLINOIS DEPARTMENT OF TRANSPORTATION
SUMMARY OF QUANTITIES
 F.A.I. ROUTE 57
 SECTION (15,21-25,21-26,27)RS-1
 DOUGLAS COUNTY

SCALE: N/A
 DATE: 08-12-08

DRAWN BY: JP
 CHECKED BY: KD

PLOT DATE = 8/21/2008
 FILE NAME = c:\pwork\70465\70465.dgn
 PLOT SCALE = 1/8"=1'-0" / IN.
 USER NAME = aheath

F.A.I. RTE.	SECTION	COUNTY	TOTAL SHEETS	SHEET NO.
57	*	DOUGLAS	76	8

* (15,21-25,21-26,27)RS-1

SUMMARY OF QUANTITIES

CODE NO.	DESCRIPTION	UNIT	LOCATION OF WORK:			
			TOTAL QUANTITY	I-57 DOUGLAS COUNTY Sta. 1386+91.00 to Sta. 547+00 RURAL 90% FED 10% STATE CONSTRUCTION TYPE CODE: 1000-2A	I-57 DOUGLAS COUNTY SN 021-0001 RURAL 90% FED 10% STATE SFTY-2A	I-57 DOUGLAS COUNTY SN 021-0005 & SN 021-0006 RURAL 90% FED 10% STATE SFTY-2A
X0322729	MATERIAL TRANSFER DEVICE	TON	70,962.0	70,962.0		
X0325285	PORTLAND CEMENT CONCRETE SURFACE REMOVAL 1 1/2"	SQ YD	140.0	140.0		
X0550300	SLOPE WALL BREAKING	SQ YD	177.0			177.0
X4401705	PARTIAL DEPTH REMOVAL	SQ YD	617.0	617.0		
X4421000	PARTIAL DEPTH PATCHING	TON	216.0	216.0		
X7015005	CHANGEABLE MESSAGE SIGN	CAL DA	28.0	28.0		
Z0016200	DECK SLAB REPAIR (PARTIAL)	SQ YD	14.0			14.0
Z0030250	IMPACT ATTENUATORS, TEMPORARY (NON-REDIRECTIVE), TEST LEVEL 3	EACH	1.0		1.0	
Z0075300	TIE BARS	EACH	3,335.0	3,335.0		

* SPECIALTY ITEMS

SHEET 4 OF 4

ILLINOIS DEPARTMENT OF TRANSPORTATION
SUMMARY OF QUANTITIES
 F.A.I. ROUTE 57
 SECTION (15,21-25,21-26,27)RS-1
 DOUGLAS COUNTY

SCALE: N/A
 DATE: 08-12-08

DRAWN BY: JP
 CHECKED BY: KD

PLT DATE = 8/21/2008
 FILE NAME = c:\projects\70465\70465cover.dgn
 PLOT SCALE = 1/8"=1'-0"
 USER NAME = aheehyun

F.A.I. RTE.	SECTION	COUNTY	TOTAL SHEETS	SHEET NO.
57	*	DOUGLAS	76	9

*(15,21-25,21-26,27)RS-1

OMISSIONS FROM TYPICAL RESURFACING

STATION	TO	STATION	
1386+91		1387+81	UNDER OVERHEAD
1491+86.53		1493+66.53	UNDER OVERHEAD
125+14.09		127+41.55	DUAL STRUCTURES
151+10		152+90	UNDER OVERHEAD

EXISTING TYPICAL SECTION

STATION	TO	STATION
1386+91.00		1510+00.00 BK (STA EQ)
117+23.47 AH (STA EQ)		175+13.87

STATION EQUATION: 1510+00.00 (BK) = STA 117+23.47 (AH)

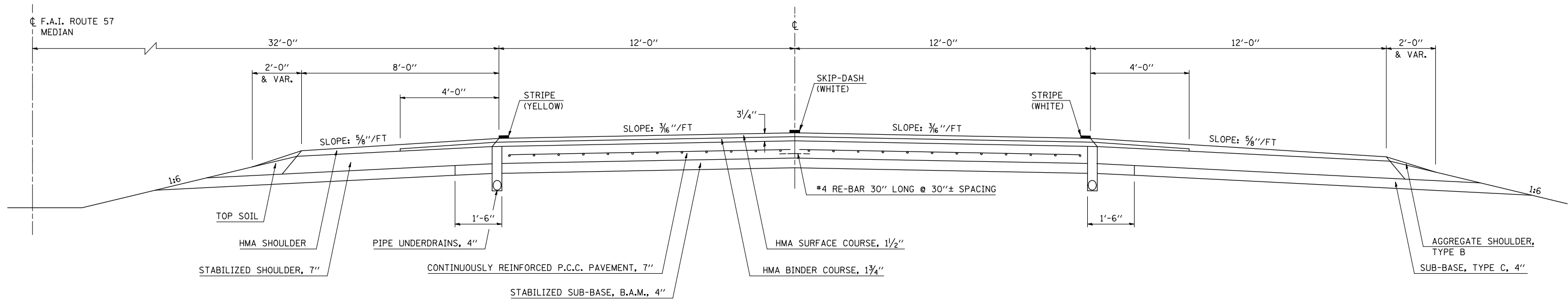

OMISSIONS FROM TYPICAL RESURFACING

STATION	TO	STATION	
323+70.06		324+81.38	DUAL STRUCTURES
422+12.05		423+07.96	DUAL STRUCTURES
528+34		530+78	DUAL STRUCTURES

EXISTING TYPICAL SECTION

STATION	TO	STATION
175+13.87		360+83.33 BK (STA EQ)
360+87.35 AH (STA EQ)		463+44.00
524+70.00		547+00.00

STATION EQUATION: 360+83.33 (BK) = STA 360+87.35 (AH)

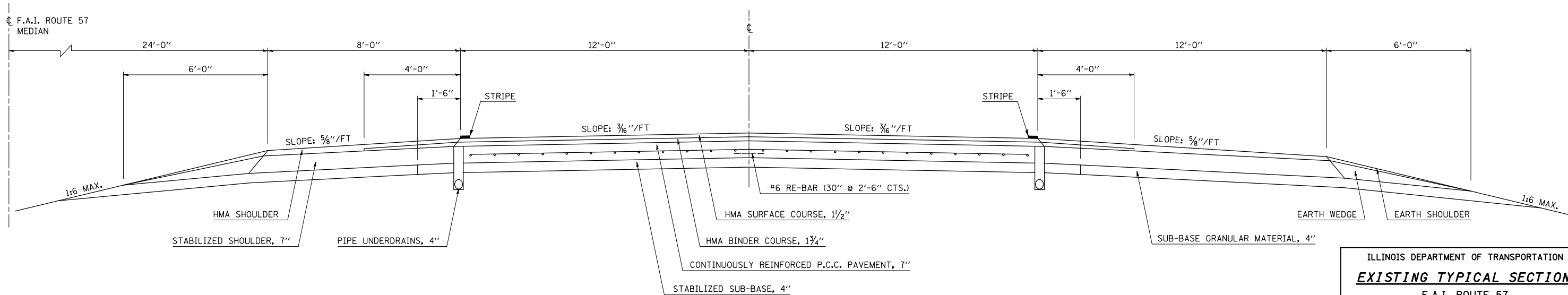

ILLINOIS DEPARTMENT OF TRANSPORTATION
EXISTING TYPICAL SECTIONS
 F.A.I. ROUTE 57
 SECTION (15,21-25,21-26,27)RS-1
 DOUGLAS COUNTY
 SCALE: NOT TO SCALE
 DATE: 01/19/06
 DRAWN BY: J.P.
 CHECKED BY: K.D.

PLOT DATE = 8/21/2006
 FILE NAME = c:\p\projects\4591385 (v8)\job\typical.dgn
 PLOT SCALE = 1/8"=1'-0"
 USER NAME = sheehyjm

F.A.I. RTE.	SECTION	COUNTY	TOTAL SHEETS	SHEET NO.
57	*	DOUGLAS	76	10

*(15,21-25,21-26,27)RS-1

OMISSIONS FROM TYPICAL RESURFACING

STATION TO STATION
463+44 464+57.15 DUAL STRUCTURES

EXISTING TYPICAL SECTION

STATION TO STATION
463+44.00 524+70.00

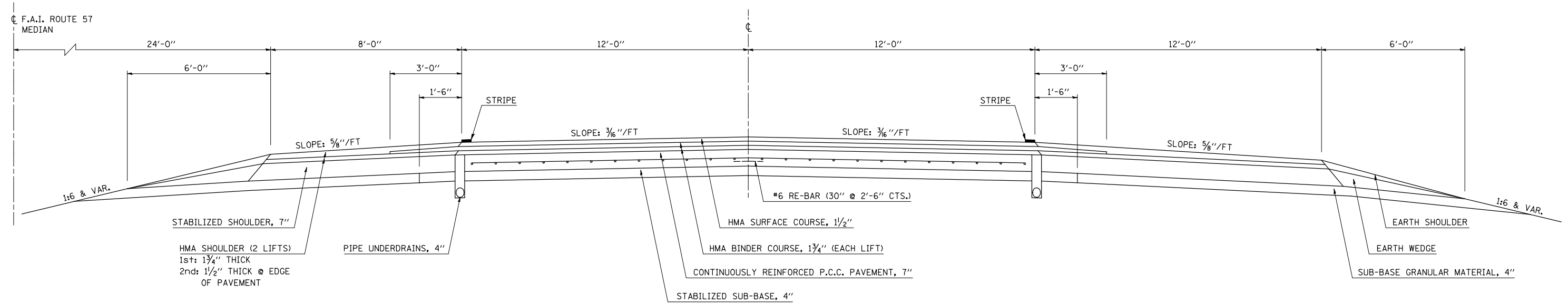

EXISTING TYPICAL SECTION

F.A.I. 57 & S.B.I. 133 INTERCHANGE RAMPS

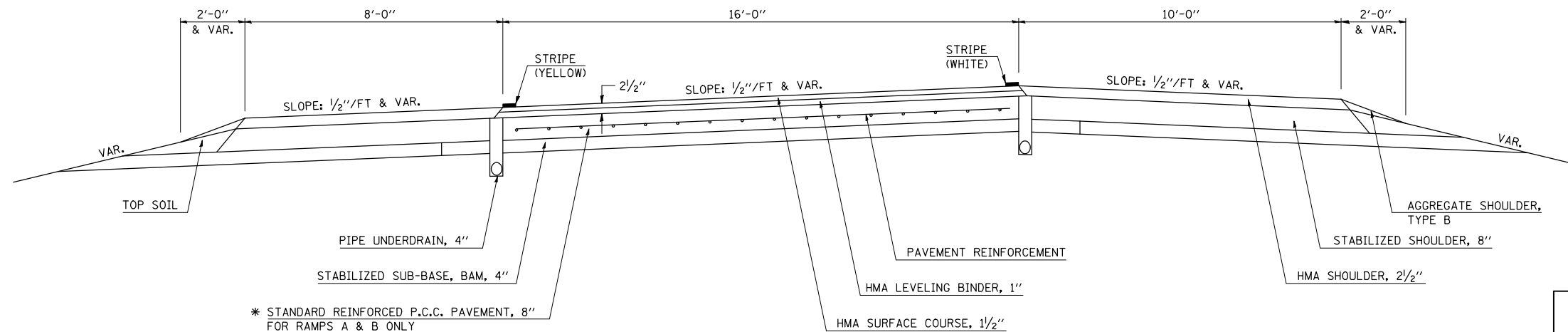

* NOTE: RAMPS C & D HAVE CONTINUOUSLY REINFORCED P.C.C. PAVEMENT, 8"

* STANDARD REINFORCED P.C.C. PAVEMENT, 8" FOR RAMPS A & B ONLY

ILLINOIS DEPARTMENT OF TRANSPORTATION
EXISTING TYPICAL SECTIONS
 F.A.I. ROUTE 57
 SECTION (15,21-25,21-26,27)RS-1
 DOUGLAS COUNTY
 SCALE: NOT TO SCALE
 DATE: 01/19/06
 DRAWN BY: J.P.
 CHECKED BY: K.D.

PLOT DATE = 8/21/2006
 FILE NAME = c:\p\projects\4591385 (v8)\job\typical.ras
 PLOT SCALE = 1/8"=1'-0"
 USER NAME = sheehyjm

F.A.I. RTE.	SECTION	COUNTY	TOTAL SHEETS	SHEET NO.
57	*	DOUGLAS	76	11

*(15,21-25,21-26,27)RS-1

EXISTING TYPICAL SECTION

F.A.I. 57 & U.S. ROUTE 36 INTERCHANGE RAMPS

STATION	TO	STATION
RAMP B: 100+00.00		110+07.30
RAMP D: 301+23.70		320+05.50

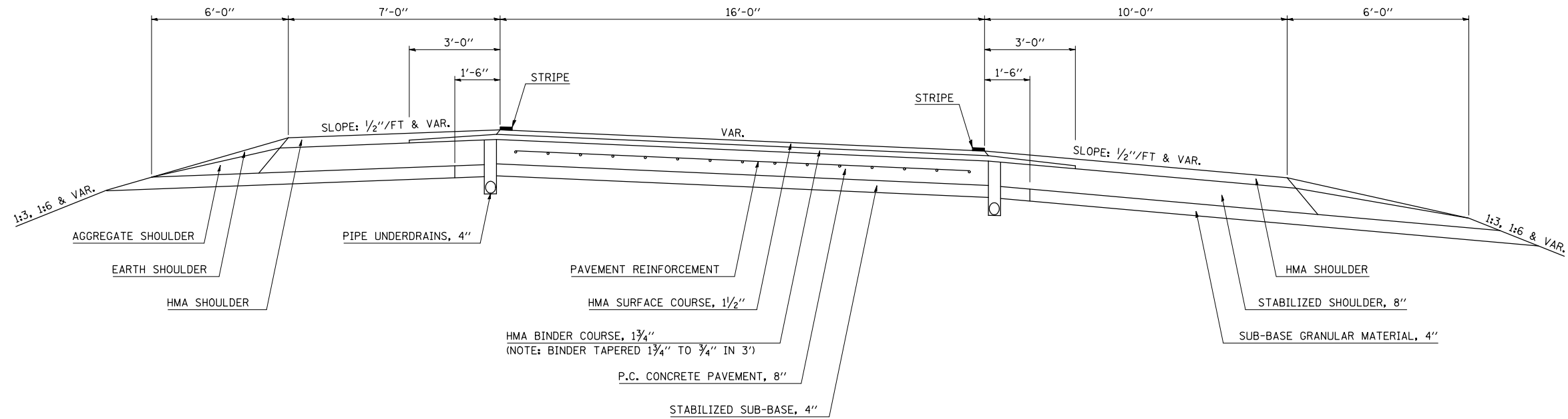

EXISTING TYPICAL SECTION

F.A.I. 57 & U.S. ROUTE 36 INTERCHANGE RAMPS

STATION	TO	STATION
RAMP A: 0+33.00		20+11.54 (STA 0+33.00; SOUTH E.P.; US RTE 36)
RAMP B: 110+07.30		117+91.68 (STA 117+91.68; SOUTH E.P.; US RTE 36)
RAMP C: 200+00.00		217+86.23 (STA 217+86.23; NORTH E.P.; US RTE 36)
RAMP D: 300+33.00		301+23.70 (STA 300+33.00; NORTH E.P.; US RTE 36)

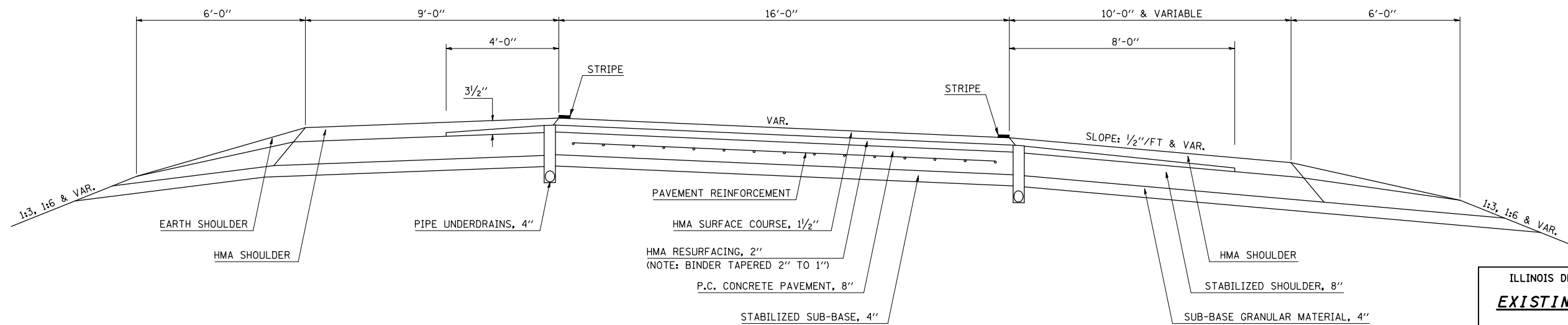

ILLINOIS DEPARTMENT OF TRANSPORTATION
EXISTING TYPICAL SECTIONS
 F.A.I. ROUTE 57
 SECTION (15,21-25,21-26,27)RS-1
 DOUGLAS COUNTY

SCALE: NOT TO SCALE
 DATE: 01/19/06
 DRAWN BY: J.P.
 CHECKED BY: K.D.

PLOT DATE = 8/21/2008
 FILE NAME = c:\projects\45901385 (v8)\job\typical.dgn
 PLOT SCALE = 1/8" = 1'-0"
 USER NAME = sheehyjm

F.A.I. RTE.	SECTION	COUNTY	TOTAL SHEETS	SHEET NO.
57	*	DOUGLAS	76	12

*(15,21-25,21-26,27)RS-1

OMISSIONS FROM TYPICAL RESURFACING

STATION	TO	STATION	DESCRIPTION
1386+91		1387+81	UNDER OVERHEAD
1491+86.53		1493+66.53	UNDER OVERHEAD (SEE DETAIL)
125+14.09		127+41.55	DUAL STRUCTURES
151+10		152+90	UNDER OVERHEAD

PROPOSED TYPICAL SECTION ①

STATION	TO	STATION	DESCRIPTION
1386+91.00		1510+00.00	BK (STA EQ)
117+23.47		175+13.87	AH (STA EQ)

STATION EQUATION: 1510+00.00 (BK) = STA 117+23.47 (AH)

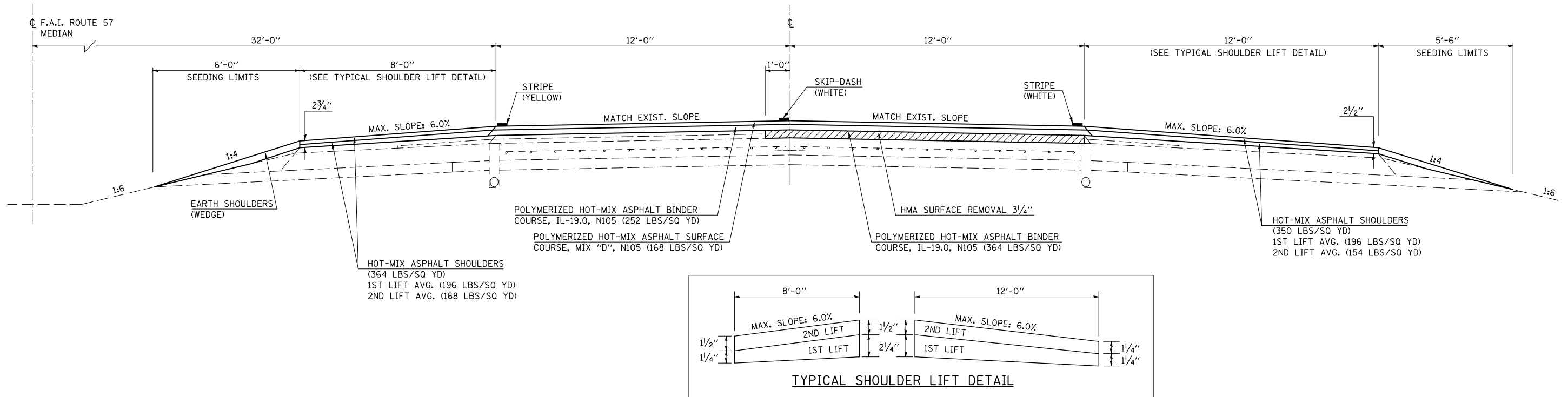

OMISSIONS FROM TYPICAL RESURFACING (SOUTHBOUND)

STATION	TO	STATION	DESCRIPTION
323+70.06		324+81.38	BRIDGE
380+27.45		382+07.45	UNDER OVERHEAD (SEE DETAIL)
421+86.60		422+80.38	BRIDGE
437+20.35		439+00.35	UNDER OVERHEAD (SEE DETAIL)
528+35.17		530+78.85	BRIDGE

SOUTHBOUND LANES

STATION	TO	STATION	DESCRIPTION
① 175+13.87		360+83.33	BK (STA EQ)
③ 524+70.00		528+35.17	AH (STA EQ)
		547+00.00	

STATION EQUATION:
360+83.33 (BK) = STA 360+87.35 (AH)

PROPOSED TYPICAL SECTION 2A

NORTHBOUND LANES

STATION	TO	STATION	DESCRIPTION
① 175+13.87		310+00.00	②B
②B 330+00.00		360+83.33	BK (STA EQ)
③ 524+70.00		390+00.00	②B
		528+33.59	
		547+00.00	

OMISSIONS FROM TYPICAL RESURFACING (NORTHBOUND)

STATION	TO	STATION	DESCRIPTION
380+27.45		382+07.45	UNDER OVERHEAD (SEE DETAIL)
528+33.59		530+77.40	BRIDGE

STATION EQUATION:
360+83.33 (BK) = STA 360+87.35 (AH)

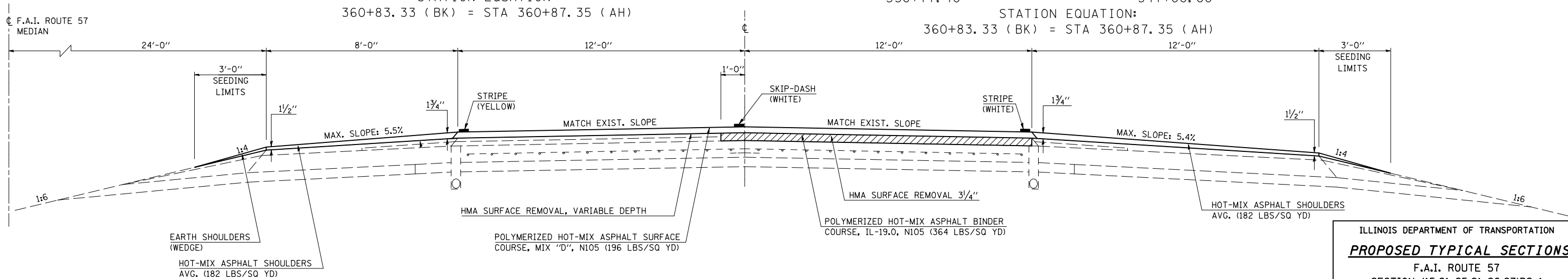

ILLINOIS DEPARTMENT OF TRANSPORTATION
PROPOSED TYPICAL SECTIONS
F.A.I. ROUTE 57
SECTION (15,21-25,21-26,27)RS-1
DOUGLAS COUNTY

SCALE: NOT TO SCALE
DATE: 01/19/06
DRAWN BY: J.P.
CHECKED BY: K.D.

F.A.I. RTE.	SECTION	COUNTY	TOTAL SHEETS	SHEET NO.
57	*	DOUGLAS	76	13

*(15,21-25,21-26,27)RS-1

OMISSIONS FROM TYPICAL RESURFACING

(NORTHBOUND)

STATION	TO	STATION	
323+70.06		324+81.38	BRIDGE
422+36.40		423+31.30	BRIDGE
437+20.35		439+00.35	UNDER OVERHEAD (SEE DETAIL)
463+19.00		463+44.00	BRIDGE

PROPOSED TYPICAL SECTION

(2B)

NORTHBOUND LANES ONLY	STATION	TO	STATION
(2A)	310+00.00		330+00.00 (2A)
(2A)	390+00.00		463+44.00 (3)

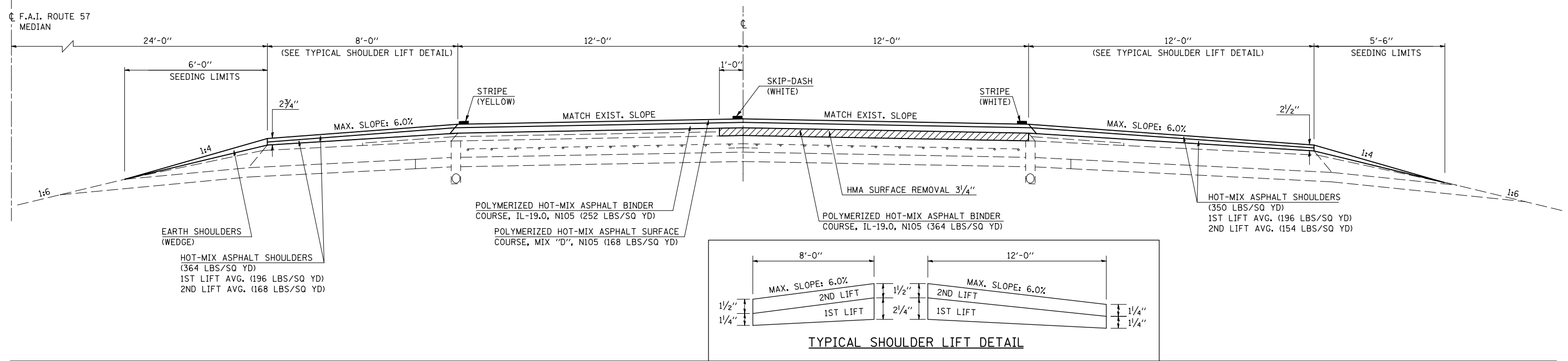

OMISSIONS FROM RESURFACING

STATION	TO	STATION	
NB 463+44.00		464+30.00	BRIDGE
SB 463+69.00		464+82.00	BRIDGE

PROPOSED TYPICAL SECTION

(3)

STATION	TO	STATION
463+44.00		524+70.00 (2A)

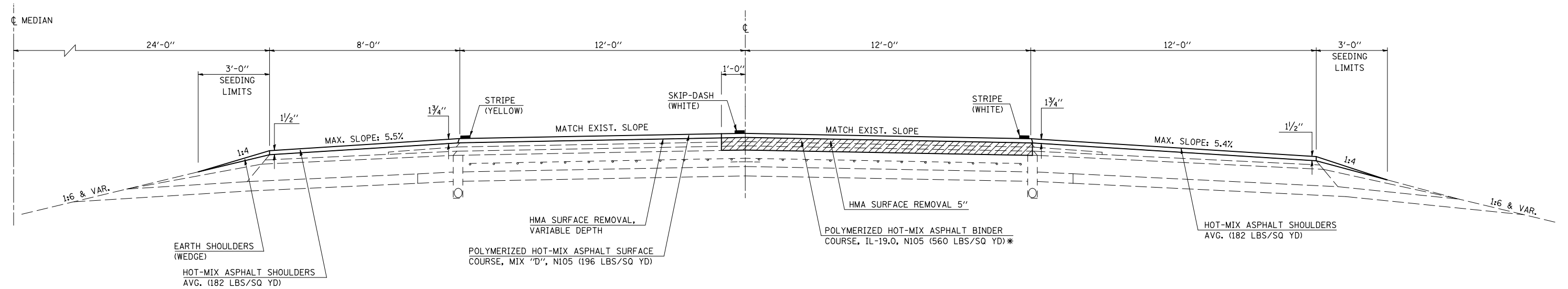

NOTE:
* IL 19.0 BINDER SHALL BE PLACED IN 2 LIFTS WITH THE MINIMUM LIFT THICKNESS BEING 2/4".

ILLINOIS DEPARTMENT OF TRANSPORTATION
PROPOSED TYPICAL SECTIONS
F.A.I. ROUTE 57
SECTION (15,21-25,21-26,27)RS-1
DOUGLAS COUNTY

SCALE: NOT TO SCALE
DATE: 01/19/06
DRAWN BY: J.P.
CHECKED BY: K.D.

F.A.I. RTE.	SECTION	COUNTY	TOTAL SHEETS	SHEET NO.
57	*	DOUGLAS	76	14

*(15,21-25,21-26,27)RS-1

PROPOSED TYPICAL SECTION

F.A.I. 57 & S.B.I. 133 INTERCHANGE RAMPS

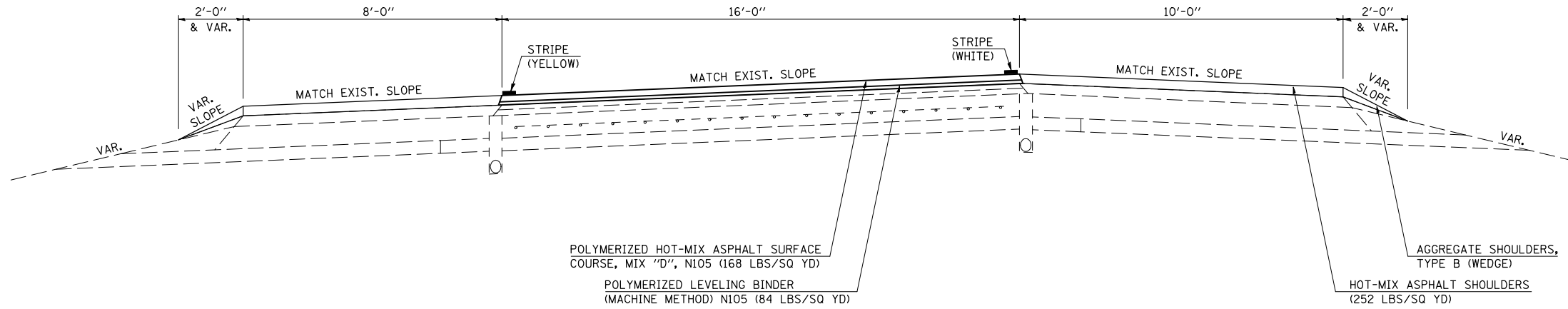

PROPOSED TYPICAL SECTION

F.A.I. 57 & U.S. ROUTE 36 INTERCHANGE RAMPS

STATION	TO	STATION
RAMP B: 101+54.00		110+07.30
RAMP D: 301+23.70		318+00.00

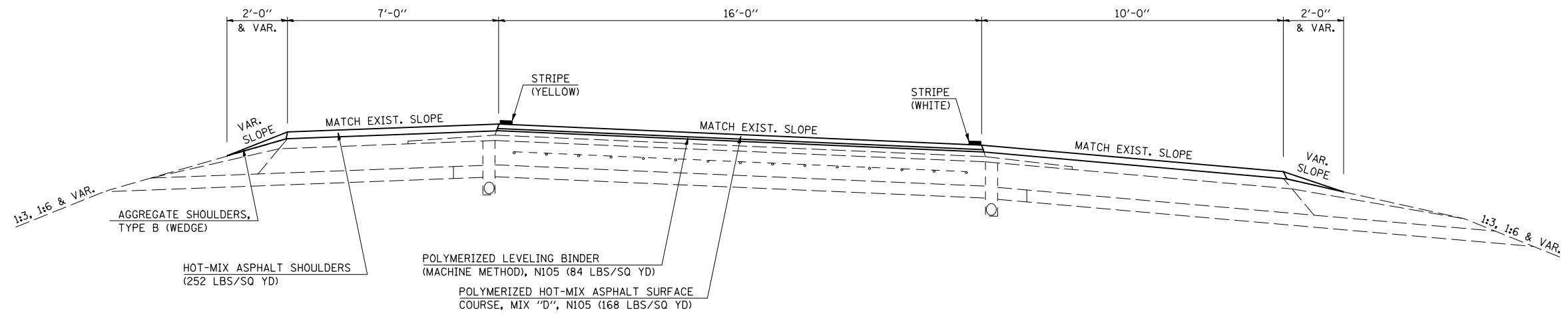

ILLINOIS DEPARTMENT OF TRANSPORTATION
PROPOSED TYPICAL SECTIONS
 F.A.I. ROUTE 57
 SECTION (15,21-25,21-26,27)RS-1
 DOUGLAS COUNTY

SCALE: NOT TO SCALE
 DATE: 01/19/06
 DRAWN BY: J.P.
 CHECKED BY: K.D.

F.A.I. RTE.	SECTION	COUNTY	TOTAL SHEETS	SHEET NO.
57	*	DOUGLAS	76	15

*(15,21-25,21-26,27)RS-1

PROPOSED TYPICAL SECTION

F.A.I. 57 & U.S. ROUTE 36 INTERCHANGE RAMPS

RAMP	STATION	TO	STATION	DETAILS
RAMP A:	0+33.00		16+92.00	(STA 0+33.00; SOUTH E. P.; US RTE 36)
RAMP B:	110+07.30		117+91.68	(STA 117+91.68; SOUTH E. P.; US RTE 36)
RAMP C:	200+85.00		217+86.23	(STA 217+86.23; NORTH E. P.; US RTE 36)
RAMP D:	300+33.00		301+23.70	(STA 300+33.00; NORTH E. P.; US RTE 36)

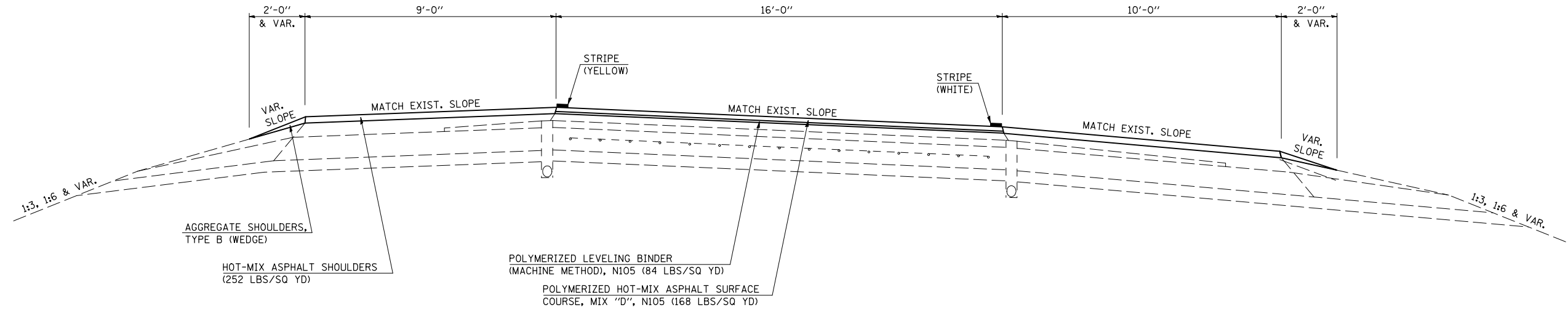

PLOT DATE = 8/21/2006
 FILE NAME = c:\projects\4591385 (v8)\job\typical.dgn
 PLOT SCALE = 1/8"=1'-0" / IN.
 USER NAME = sheehyjm

ILLINOIS DEPARTMENT OF TRANSPORTATION
PROPOSED TYPICAL SECTIONS
 F.A.I. ROUTE 57
 SECTION (15,21-25,21-26,27)RS-1
 DOUGLAS COUNTY

SCALE: NOT TO SCALE
 DATE: 01/19/06
 DRAWN BY: J.P.
 CHECKED BY: K.D.

F.A.I. RTE.	SECTION	COUNTY	TOTAL SHEETS	SHEET NO.
57	*	DOUGLAS	76	16

* (15,21-25,21-26,27)RS-1

SCHEDULE OF QUANTITIES

NORTHBOUND HMA QUANTITIES

DESCRIPTION	STATION	TO	STATION	LENGTH (FOOT)	WIDTH (FOOT)	AREA (SQ YD)	HMA SURFACE COURSE THICKNESS (INCH)	HMA BINDER COURSE THICKNESS (INCH)	HMA LEVELING BINDER THICKNESS (INCH)	40603550 POLYMERIZED HMA SURFACE COURSE MIX "D", N105 (TON)	40603245 POLYMERIZED HMA BINDER COURSE IL 19.0, N105 (TON)	40600855 POLYMERIZED LEVELING BINDER MM, N105 (TON)	40600100 BITUMINOUS MATERIALS PRIME COAT (GAL)	40600300 AGGREGATE PRIME COAT (TON)	X0322729 MATERIAL TRANSFER DEVICE (TON)
MAINLINE QUANTITIES															
NBDL	1387+81.00	TO	1491+86.53	10,405.5	13.0	15,030.2	1.5	5.50	-	1,262.5	4,629.3	-	1,503.0	30.1	5,891.8
NBPL	1387+81.00	TO	1491+86.53	10,405.5	11.0	12,717.9	1.5	2.25	-	1,068.3	1,602.5	-	1,271.8	25.4	2,670.8
NBDL	1493+66.53	TO	1510+00.00 (BK)	1,633.5	13.0	2,359.5	1.5	5.50	-	198.2	726.7	-	235.9	4.7	924.9
NBPL	1493+66.53	TO	1510+00.00 (BK)	1,633.5	11.0	1,996.5	1.5	2.25	-	167.7	251.6	-	199.6	4.0	419.3
NBDL	117+23.47 (AH)	TO	122+65.81	542.3	13.0	783.4	1.5	5.50	-	65.8	241.3	-	78.3	1.6	307.1
NBPL	117+23.47 (AH)	TO	122+65.81	542.3	11.0	662.9	1.5	2.25	-	55.7	83.5	-	66.3	1.3	139.2
NBDL	122+65.81	TO	125+14.09	248.3	13.0	358.6	1.5	2.25	-	30.1	45.2	-	35.9	0.7	75.3
NBPL	122+65.81	TO	125+14.09	248.3	11.0	303.5	1.5	2.25	-	25.5	38.2	-	30.3	0.6	63.7
NBDL	127+41.55	TO	129+62.99	221.4	13.0	319.9	1.5	2.25	-	26.9	40.3	-	32.0	0.6	67.2
NBPL	127+41.55	TO	129+62.99	221.4	11.0	270.6	1.5	2.25	-	22.7	34.1	-	27.1	0.5	56.8
NBDL	129+62.99	TO	151+10.00	2,147.0	13.0	3,101.2	1.5	5.50	-	260.5	955.2	-	310.1	6.2	1,215.7
NBPL	129+62.99	TO	151+10.00	2,147.0	11.0	2,624.1	1.5	2.25	-	220.4	330.6	-	262.4	5.2	551.1
NBDL	152+90.00	TO	175+13.87	2,223.9	13.0	3,212.3	1.5	5.50	-	269.8	989.4	-	321.2	6.4	1,259.2
NBPL	152+90.00	TO	175+13.87	2,223.9	11.0	2,718.1	1.5	2.25	-	228.3	342.5	-	271.8	5.4	570.8
NBDL	175+13.87	TO	309+40.00	13,426.1	13.0	19,393.3	1.75	3.25	-	1,900.5	3,529.6	-	1,939.3	38.8	5,430.1
NBPL	175+13.87	TO	309+40.00	13,426.1	11.0	16,409.7	1.75	0.00	-	1,608.2	0.0	-	1,641.0	32.8	1,608.2
NBDL	309+40.00	TO	323+70.06	1,430.1	13.0	2,065.6	1.5	5.50	-	173.5	636.2	-	206.6	4.1	809.7
NBPL	309+40.00	TO	323+70.06	1,430.1	11.0	1,747.9	1.5	2.25	-	146.8	220.2	-	174.8	3.5	367.0
NBDL	324+81.38	TO	330+00.00	518.6	13.0	749.1	1.5	5.50	-	62.9	230.7	-	74.9	1.5	293.7
NBPL	324+81.38	TO	330+00.00	518.6	11.0	633.9	1.5	2.25	-	53.2	79.9	-	63.4	1.3	133.1
NBDL	330+00.00	TO	360+83.33 (BK)	3,083.3	13.0	4,453.7	1.75	3.25	-	436.5	810.6	-	445.4	8.9	1,247.0
NBPL	330+00.00	TO	360+83.33 (BK)	3,083.3	11.0	3,768.5	1.75	0.00	-	369.3	0.0	-	376.9	7.5	369.3
NBDL	360+87.35 (AH)	TO	380+27.45	1,940.1	13.0	2,802.4	1.75	3.25	-	274.6	510.0	-	280.2	5.6	784.7
NBPL	360+87.35 (AH)	TO	380+27.45	1,940.1	11.0	2,371.2	1.75	0.00	-	232.4	0.0	-	237.1	4.7	232.4
NBDL	380+27.45	TO	382+07.45	180.0	13.0	260.0	1.5	1.75	-	21.8	25.5	-	26.0	0.5	47.3
NBPL	380+27.45	TO	382+07.45	180.0	11.0	220.0	1.5	1.75	-	18.5	21.6	-	22.0	0.4	40.0
NBDL	382+07.45	TO	389+40.00	732.6	13.0	1,058.1	1.75	3.25	-	103.7	192.6	-	105.8	2.1	296.3
NBPL	382+07.45	TO	389+40.00	732.6	11.0	895.3	1.75	0.00	-	87.7	0.0	-	89.5	1.8	87.7
NBDL	389+40.00	TO	422+36.40	3,296.4	13.0	4,761.5	1.5	5.50	-	400.0	1,466.5	-	476.1	9.5	1,866.5
NBPL	389+40.00	TO	422+36.40	3,296.4	11.0	4,028.9	1.5	2.25	-	338.4	507.6	-	402.9	8.1	846.1
NBDL	423+31.30	TO	437+20.35	1,389.1	13.0	2,006.4	1.5	5.50	-	168.5	618.0	-	200.6	4.0	786.5
NBPL	423+31.30	TO	437+20.35	1,389.1	11.0	1,697.7	1.5	2.25	-	142.6	213.9	-	169.8	3.4	356.5
NBDL	437+20.35	TO	439+00.35	180.0	13.0	260.0	1.5	1.75	-	21.8	25.5	-	26.0	0.5	47.3
NBPL	437+20.35	TO	439+00.35	180.0	11.0	220.0	1.5	1.75	-	18.5	21.6	-	22.0	0.4	40.0
NBDL	439+00.35	TO	463+19.00	2,418.7	13.0	3,493.6	1.5	5.50	-	293.5	1,076.0	-	349.4	7.0	1,369.5
NBPL	439+00.35	TO	463+19.00	2,418.7	11.0	2,956.1	1.5	2.25	-	248.3	372.5	-	295.6	5.9	620.8
NBDL	464+30.00	TO	524+70.00	6,040.0	13.0	8,724.4	1.75	5.00	-	855.0	2,442.8	-	872.4	17.4	3,297.8
NBPL	464+30.00	TO	524+70.00	6,040.0	11.0	7,382.2	1.75	0.00	-	723.5	0.0	-	738.2	14.8	723.5
NBDL	524+70.00	TO	525+41.80	71.8	13.0	103.7	1.75	3.25	-	10.2	18.9	-	10.4	0.2	29.0
NBPL	524+70.00	TO	525+41.80	71.8	11.0	87.8	1.75	0.00	-	8.6	0.0	-	8.8	0.2	8.6
NBDL	525+41.80	TO	528+33.59	291.8	13.0	421.5	1.75	0.00	-	41.3	0.0	-	42.1	0.8	41.3
NBPL	525+41.80	TO	528+33.59	291.8	11.0	356.6	1.75	0.00	-	34.9	0.0	-	35.7	0.7	34.9
NBDL	530+77.40	TO	534+03.00	325.6	13.0	470.3	1.75	0.00	-	46.1	0.0	-	47.0	0.9	46.1
NBPL	530+77.40	TO	534+03.00	325.6	11.0	398.0	1.75	0.00	-	39.0	0.0	-	39.8	0.8	39.0
NBDL	534+03.00	TO	547+00.00	1,297.0	13.0	1,873.4	1.75	3.25	-	183.6	341.0	-	187.3	3.7	524.6
NBPL	534+03.00	TO	547+00.00	1,297.0	11.0	1,585.2	1.75	0.00	-	155.4	0.0	-	158.5	3.2	155.4
SUB-TOTAL =										13,121.4	23,671.5	0.0	14,411.5	288.2	36,792.9
NB RAMP TAPER QUANTITIES															
IL 133															
RAMP C	375+46.98	TO	382+23.00	676.0	VAR	943.0	1.5	5.50	-	79.2	290.4	-	94.3	1.9	-
RAMP B	241+23.00	TO	252+03.36	1,080.4	VAR	1,248.2	1.5	5.50	-	104.9	384.5	-	124.8	2.5	-
US 36															
RAMP C	530+77.40	M.L.	TO	534+03.00	M.L.	325.6	VAR	654.6	1.75	0.00	-	-	65.5	1.3	-
RAMP C	534+03.00	M.L.	TO	200+85.00		128.0	VAR	269.3	1.75	0.00	-	-	26.9	0.5	-
RAMP D	318+00.00	TO	320+11.00	211.0	VAR	331.6	1.75	0.00	-	32.5	0.0	-	33.2	0.7	-
SUB-TOTAL =										307.1	674.9	0.0	344.7	6.9	0.0
SHEET TOTAL =										13,428.5	24,346.4	0.0	14,756.1	295.1	36,792.9

PLOT DATE = 8/21/2008
 FILE NAME = c:\p\projects\70465\70465scover.dgn
 PLOT SCALE = 1/8"=1'-0"
 USER NAME = sheehyjm

ILLINOIS DEPARTMENT OF TRANSPORTATION
SCHEDULE OF QUANTITIES
 F.A.I. ROUTE 57
 SECTION (15,21-25,21-26,27)RS-1
 DOUGLAS COUNTY

SCALE: N/A
 DATE: 08-07-08

DRAWN BY: RC
 CHECKED BY: KD

F.A.I. RTE.	SECTION	COUNTY	TOTAL SHEETS	SHEET NO.
57	*	DOUGLAS	76	17

* (15,21-25,21-26,27)RS-1

SCHEDULE OF QUANTITIES

SOUTHBOUND HMA QUANTITIES															
DESCRIPTION	STATION	TO	STATION	LENGTH (FOOT)	WIDTH (FOOT)	AREA (SQ YD)	HMA SURFACE COURSE THICKNESS (INCH)	HMA BINDER COURSE THICKNESS (INCH)	HMA LEVELING BINDER THICKNESS (INCH)	40603550 POLYMERIZED HMA SURFACE COURSE MIX "D", N105 (TON)	40603245 POLYMERIZED HMA BINDER COURSE IL 19.0, N105 (TON)	40600855 POLYMERIZED LEVELING BINDER MM, N105 (TON)	40600100 BITUMINOUS MATERIALS PRIME COAT (GAL)	40600300 AGGREGATE PRIME COAT (TON)	X0322729 MATERIAL TRANSFER DEVICE (TON)
MAINLINE QUANTITIES															
SBDL	1387+81.00	TO	1491+86.53	10,405.5	13.0	15,030.2	1.50	5.50	-	1,262.5	4,629.3	-	1,503.0	30.1	5,891.8
SBPL	1387+81.00	TO	1491+86.53	10,405.5	11.0	12,717.9	1.50	2.25	-	1,068.3	1,602.5	-	1,271.8	25.4	2,670.8
SBDL	1491+86.53	TO	1493+66.53	180.0	13.0	260.0	1.50	1.75	-	21.8	25.5	-	26.0	0.5	47.3
SBPL	1491+86.53	TO	1493+66.53	180.0	11.0	220.0	1.50	1.75	-	18.5	21.6	-	22.0	0.4	40.0
SBDL	1493+66.53	TO	1510+00.00 (BK)	1,633.5	13.0	2,359.5	1.50	5.50	-	198.2	726.7	-	235.9	4.7	924.9
SBPL	1493+66.53	TO	1510+00.00 (BK)	1,633.5	11.0	1,996.5	1.50	2.25	-	167.7	251.6	-	199.6	4.0	419.3
SBDL	117+23.47 (AH)	TO	122+65.81	542.3	13.0	783.4	1.50	5.50	-	65.8	241.3	-	78.3	1.6	307.1
SBPL	117+23.47 (AH)	TO	122+65.81	542.3	11.0	662.9	1.50	2.25	-	55.7	83.5	-	66.3	1.3	139.2
SBDL	122+65.81	TO	125+14.09	248.3	13.0	358.6	1.50	2.25	-	30.1	45.2	-	35.9	0.7	75.3
SBPL	122+65.81	TO	125+14.09	248.3	11.0	303.5	1.50	2.25	-	25.5	38.2	-	30.3	0.6	63.7
SBDL	127+41.55	TO	129+62.99	221.4	13.0	319.9	1.50	2.25	-	26.9	40.3	-	32.0	0.6	67.2
SBPL	127+41.55	TO	129+62.99	221.4	11.0	270.6	1.50	2.25	-	22.7	34.1	-	27.1	0.5	56.8
SBDL	129+62.99	TO	151+10.00	2,147.0	13.0	3,101.2	1.50	5.50	-	260.5	955.2	-	310.1	6.2	1,215.7
SBPL	129+62.99	TO	151+10.00	2,147.0	11.0	2,624.1	1.50	2.25	-	220.4	330.6	-	262.4	5.2	551.1
SBDL	152+90.00	TO	175+13.87	2,223.9	13.0	3,212.3	1.50	5.50	-	269.8	989.4	-	321.2	6.4	1,259.2
SBPL	152+90.00	TO	175+13.87	2,223.9	11.0	2,718.1	1.50	2.25	-	228.3	342.5	-	271.8	5.4	570.8
SBDL	175+13.87	TO	323+70.06	14,856.2	13.0	21,458.9	1.75	3.25	-	2,103.0	3,905.5	-	2,145.9	42.9	6,008.5
SBPL	175+13.87	TO	323+70.06	14,856.2	11.0	18,157.6	1.75	0.00	-	1,779.4	0.0	-	1,815.8	36.3	1,779.4
SBDL	324+81.38	TO	360+83.33 (BK)	3,602.0	13.0	5,202.8	1.75	3.25	-	509.9	946.9	-	520.3	10.4	1,456.8
SBPL	324+81.38	TO	360+83.33 (BK)	3,602.0	11.0	4,402.4	1.75	0.00	-	431.4	0.0	-	440.2	8.8	431.4
SBDL	360+87.35 (AH)	TO	380+27.45	1,940.1	13.0	2,802.4	1.75	3.25	-	274.6	510.0	-	280.2	5.6	784.7
SBPL	360+87.35 (AH)	TO	380+27.45	1,940.1	11.0	2,371.2	1.75	0.00	-	232.4	0.0	-	237.1	4.7	232.4
SBDL	380+27.45	TO	382+07.45	180.0	13.0	260.0	1.50	1.75	-	21.8	25.5	-	26.0	0.5	47.3
SBPL	380+27.45	TO	382+07.45	180.0	11.0	220.0	1.50	1.75	-	18.5	21.6	-	22.0	0.4	40.0
SBDL	382+07.45	TO	421+86.60	3,979.2	13.0	5,747.7	1.75	3.25	-	563.3	1,046.1	-	574.8	11.5	1,609.3
SBPL	382+07.45	TO	421+86.60	3,979.2	11.0	4,863.4	1.75	0.00	-	476.6	0.0	-	486.3	9.7	476.6
SBDL	422+80.38	TO	437+20.35	1,440.0	13.0	2,080.0	1.75	3.25	-	203.8	378.6	-	208.0	4.2	582.4
SBPL	422+80.38	TO	437+20.35	1,440.0	11.0	1,760.0	1.75	0.00	-	172.5	0.0	-	176.0	3.5	172.5
SBDL	437+20.35	TO	439+00.35	180.0	13.0	260.0	1.50	1.75	-	21.8	25.5	-	26.0	0.5	47.3
SBPL	437+20.35	TO	439+00.35	180.0	11.0	220.0	1.50	1.75	-	18.5	21.6	-	22.0	0.4	40.0
SBDL	439+00.35	TO	463+69.00	2,468.7	13.0	3,565.8	1.75	3.25	-	349.5	649.0	-	356.6	7.1	998.4
SBPL	439+00.35	TO	463+69.00	2,468.7	11.0	3,017.2	1.75	0.00	-	295.7	0.0	-	301.7	6.0	295.7
SBDL	464+82.00	TO	524+70.00	5,988.0	13.0	8,649.3	1.75	5.00	-	847.6	2,421.8	-	864.9	17.3	3,269.4
SBPL	464+82.00	TO	524+70.00	5,988.0	11.0	7,318.7	1.75	0.00	-	717.2	0.0	-	731.9	14.6	717.2
SBDL	524+70.00	TO	525+39.90	69.9	13.0	101.0	1.75	3.25	-	9.9	18.4	-	10.1	0.2	28.3
SBPL	524+70.00	TO	525+39.90	69.9	11.0	85.4	1.75	0.00	-	8.4	0.0	-	8.5	0.2	8.4
SBDL	525+39.90	TO	528+35.17	295.3	13.0	426.5	1.75	0.00	-	41.8	0.0	-	42.7	0.9	41.8
SBPL	525+39.90	TO	528+35.17	295.3	11.0	360.9	1.75	0.00	-	35.4	0.0	-	36.1	0.7	35.4
SBDL	530+78.35	TO	534+03.00	324.7	13.0	468.9	1.75	0.00	-	46.0	0.0	-	46.9	0.9	46.0
SBPL	530+78.35	TO	534+03.00	324.7	11.0	396.8	1.75	0.00	-	38.9	0.0	-	39.7	0.8	38.9
SBDL	534+03.00	TO	547+00.00	1,297.0	13.0	1,873.4	1.75	3.25	-	183.6	341.0	-	187.3	3.7	524.6
SBPL	534+03.00	TO	547+00.00	1,297.0	11.0	1,585.2	1.75	0.00	-	155.4	0.0	-	158.5	3.2	155.4
SUB-TOTALS =										13,499.6	20,668.7	0.0	14,459.4	289.2	34,168.3
SB RAMP TAPER QUANTITIES															
IL 133															
RAMP D	462+23.00	TO	472+50.28	1,027.3	VAR	1,153.2	1.50	5.50	-	96.9	355.2	-	115.3	2.3	-
RAMP A	109+94.49	TO	117+00.00	705.5	VAR	1,024.7	1.50	5.50	-	86.1	315.6	-	102.5	2.0	-
US 36															
RAMP A	16+92.00	TO	29+61.49	1,269.5	VAR	1,620.9	1.75	0.00	-	158.8	0.0	-	162.1	3.2	-
RAMP B	525+39.90	M.L.	101+54.00	223.9	VAR	430.1	1.75	0.00	-	42.2	0.0	-	43.0	0.9	-
RAMP B	525+39.90	M.L.	528+35.17	295.3	VAR	572.9	1.75	0.00	-	56.1	0.0	-	57.3	1.1	-
SUB-TOTALS =										440.1	670.8	0.0	480.2	9.6	0.0
SHEET TOTALS =										13,939.7	21,339.5	0.0	14,939.6	298.8	34,168.3

PLOT DATE = 8/21/2008
 FILE NAME = c:\p\projects\5801385 (v8)\78465cover.dgn
 PLOT SCALE = 1/8"=1'-0"
 USER NAME = sheehyjm

ILLINOIS DEPARTMENT OF TRANSPORTATION
SCHEDULE OF QUANTITIES
 F.A.I. ROUTE 57
 SECTION (15,21-25,21-26,27)RS-1
 DOUGLAS COUNTY
 SCALE: N/A
 DATE: 08-07-08
 DRAWN BY: RC
 CHECKED BY: KD

F.A.I. RTE.	SECTION	COUNTY	TOTAL SHEETS	SHEET NO.
57	*	DOUGLAS	76	18

* (15,21-25,21-26,27)RS-1

SCHEDULE OF QUANTITIES

INTERCHANGE RAMP HMA QUANTITIES

DESCRIPTION	STATION	TO	STATION	LENGTH (FOOT)	WIDTH (FOOT)	AREA (SQ YD)	HMA SURFACE COURSE THICKNESS (INCH)	HMA BINDER COURSE THICKNESS (INCH)	HMA LEVELING BINDER THICKNESS (INCH)	40603550 POLYMERIZED HMA SURFACE COURSE MIX "D", N105 (TON)	40603245 POLYMERIZED HMA BINDER COURSE IL 19.0, N105 (TON)	40600855 POLYMERIZED LEVELING BINDER MM, N105 (TON)	40600100 BITUMINOUS MATERIALS PRIME COAT (GAL)	40600300 AGGREGATE PRIME COAT (TON)	X0322729 MATERIAL TRANSFER DEVICE (TON)
RAMP A	IL 133	117+00.00	TO 128+55.21	1,155.2	16.0	2,053.7	1.5	-	0.75	172.5	-	86.3	205.4	4.1	-
RAMP A	IL 133	128+55.21	TO 129+67.74	112.5	VAR	460.9	1.5	-	0.75	38.7	-	19.4	46.1	0.9	-
RAMP B	IL 133	230+26.09	TO 231+26.37	100.3	VAR	410.3	1.5	-	0.75	34.5	-	17.2	41.0	0.8	-
RAMP B	IL 133	231+26.37	TO 241+23.00	996.6	16.0	1,771.8	1.5	-	0.75	148.8	-	74.4	177.2	3.5	-
RAMP C	IL 133	382+23.00	TO 394+08.27	1,185.3	16.0	2,107.1	1.5	-	0.75	177.0	-	88.5	210.7	4.2	-
RAMP C	IL 133	394+08.27	TO 395+20.80	112.5	VAR	477.0	1.5	-	0.75	40.1	-	20.0	47.7	1.0	-
RAMP D	IL 133	450+73.03	TO 451+73.08	100.1	VAR	376.6	1.5	-	0.75	31.6	-	15.8	37.7	0.8	-
RAMP D	IL 133	451+73.08	TO 462+23.00	1,049.9	16.0	1,866.5	1.5	-	0.75	156.8	-	78.4	186.7	3.7	-
SUB-TOTALS =										800.0	0.0	400.0	952.4	19.0	0.0
RAMP A	US 36	000+33.00	TO 002+52.50	219.5	VAR	518.2	1.5	-	-	43.5	-	0.0	51.8	1.0	-
RAMP A	US 36	002+52.50	TO 016+92.00	1,439.5	16.0	2,559.1	1.5	-	0.75	215.0	-	107.5	255.9	5.1	-
RAMP B	US 36	101+54.00	TO 115+72.18	1,418.2	16.0	2,521.2	1.5	-	0.75	211.8	-	105.9	252.1	5.0	-
RAMP B	US 36	115+72.18	TO 117+91.68	219.5	VAR	568.5	1.5	-	-	47.7	-	0.0	56.8	1.1	-
RAMP C	US 36	200+85.00	TO 215+66.73	1,481.7	16.0	2,634.2	1.5	-	0.75	221.3	-	110.6	263.4	5.3	-
RAMP C	US 36	215+66.73	TO 217+86.23	219.5	VAR	685.8	1.5	-	-	57.6	-	0.0	68.6	1.4	-
RAMP D	US 36	300+33.00	TO 302+52.50	219.5	VAR	501.7	1.5	-	-	42.1	-	0.0	50.2	1.0	-
RAMP D	US 36	302+52.50	TO 318+00.00	1,547.5	16.0	2,751.1	1.5	-	0.75	231.1	-	115.5	275.1	5.5	-
SUB-TOTALS =										1,070.1	0.0	439.6	1,274.0	25.5	0.0
INTERCHANGE RAMP TOTALS =										1,870.1	0.0	839.6	2,226.4	44.5	0.0
SHEET 16 NORTHBOUND TOTALS =										13,428.5	24,346.4	0.0	14,756.1	295.1	36,792.9
SHEET 17 SOUTHBOUND TOTALS =										13,939.7	21,339.5	0.0	14,939.6	298.8	34,168.3
TOTALS =										29,238.4	45,685.8	839.6	31,922.1	638.4	70,961.2
USE =										29,239.0	45,686.0	840.0	31,922.0	638.0	70,962.0

PLOT DATE = 8/21/2008
 FILE NAME = c:\p\projects\4591385 (v8)\70465\cover.dgn
 PLOT SCALE = 1/8"=1'-0"
 USER NAME = sheehyjm

ILLINOIS DEPARTMENT OF TRANSPORTATION
SCHEDULE OF QUANTITIES
 F.A.I. ROUTE 57
 SECTION (15,21-25,21-26,27)RS-1
 DOUGLAS COUNTY

SCALE: N/A
 DATE: 08-07-08

DRAWN BY: RC
 CHECKED BY: KD

F.A.I. RTE.	SECTION	COUNTY	TOTAL SHEETS	SHEET NO.
57	*	DOUGLAS	76	19

* (15,21-25,21-26,27)RS-1

SCHEDULE OF QUANTITIES

NORTHBOUND HOT MIX ASPHALT SHOULDERS										
DESCRIPTION	STATION	TO	STATION	LENGTH (FOOT)	WIDTH (FOOT)	AREA (SQ YD)	AVERAGE SHOULDER THICKNESS (INCH)	48203100 HMA SHOULDER (TON)	40600100 BIT MATLS PRIME COAT (GAL)	40600300 AGGREGATE PRIME COAT (TON)
MAINLINE QUANTITIES										
NORTHBOUND	RT 1386+91.00	TO	RT 1387+81.00	90.0	12.0	120.0	1.500	10.1	12.0	0.2
NORTHBOUND	RT 1387+81.00	TO	RT 1475+46.98	8,766.0	12.0	11,688.0	3.125	2,045.4	1,168.8	23.4
NORTHBOUND	RT 1482+25.00	TO	RT 1491+86.53	961.5	12.0	1,282.0	3.125	224.4	128.2	2.6
NORTHBOUND	RT 1491+86.53	TO	RT 1493+66.53	180.0	12.0	240.0	1.500	20.2	24.0	0.5
NORTHBOUND	RT 1493+66.53	TO	RT 1501+20.00	753.5	12.0	1,004.6	3.125	175.8	100.5	2.0
NORTHBOUND	RT 119+26.82	TO	RT 125+14.09	587.3	12.0	783.0	3.125	137.0	78.3	1.6
NORTHBOUND	RT 127+41.55	TO	RT 151+10.00	2,368.5	12.0	3,157.9	3.125	552.6	315.8	6.3
NORTHBOUND	RT 151+10.00	TO	RT 152+90.00	180.0	12.0	240.0	1.500	20.2	24.0	0.5
NORTHBOUND	RT 152+90.00	TO	RT 175+13.87	2,223.9	12.0	2,965.2	3.125	518.9	296.5	5.9
NORTHBOUND	RT 175+13.87	TO	RT 309+40.00	13,426.1	12.0	17,901.5	1.625	1,629.0	1,790.2	35.8
NORTHBOUND	RT 309+40.00	TO	RT 323+70.06	1,430.1	12.0	1,906.7	3.125	333.7	190.7	3.8
NORTHBOUND	RT 324+81.38	TO	RT 330+00.00	518.6	12.0	691.5	3.125	121.0	69.1	1.4
NORTHBOUND	RT 330+00.00	TO	RT 360+83.33 (BK)	3,083.3	12.0	4,111.1	1.625	374.1	411.1	8.2
NORTHBOUND	RT 360+87.35 (AH)	TO	RT 380+27.45	1,940.1	12.0	2,586.8	1.625	235.4	258.7	5.2
NORTHBOUND	RT 380+27.45	TO	RT 382+07.45	180.0	12.0	240.0	3.250	43.7	24.0	0.5
NORTHBOUND	RT 382+07.45	TO	RT 389+40.00	732.6	12.0	976.7	1.625	88.9	97.7	2.0
NORTHBOUND	RT 389+40.00	TO	RT 422+36.40	3,296.4	12.0	4,395.2	3.125	769.2	439.5	8.8
NORTHBOUND	RT 423+31.30	TO	RT 437+20.35	1,389.1	12.0	1,852.1	3.125	324.1	185.2	3.7
NORTHBOUND	RT 437+20.35	TO	RT 439+00.35	180.0	12.0	240.0	3.250	43.7	24.0	0.5
NORTHBOUND	RT 439+00.35	TO	RT 463+19.00	2,418.7	12.0	3,224.9	3.125	564.4	322.5	6.4
NORTHBOUND	RT 464+30.00	TO	RT 528+33.59	6,403.6	12.0	8,538.1	1.625	777.0	853.8	17.1
NORTHBOUND	RT 535+42.00	TO	RT 544+92.00	950.0	12.0	1,266.7	1.625	115.3	126.7	2.5
NORTHBOUND	LT 1386+91.00	TO	LT 1387+81.00	90.0	8.0	80.0	1.500	6.7	8.0	0.2
NORTHBOUND	LT 1387+81.00	TO	LT 1491+86.53	10,405.5	8.0	9,249.4	3.250	1,683.4	924.9	18.5
NORTHBOUND	LT 1491+86.53	TO	LT 1493+66.53	180.0	8.0	160.0	1.500	13.4	16.0	0.3
NORTHBOUND	LT 1493+66.53	TO	LT 1510+00.00 (BK)	1,633.5	8.0	1,452.0	3.250	264.3	145.2	2.9
NORTHBOUND	LT 117+23.47 (AH)	TO	LT 125+14.09	790.6	8.0	702.8	3.250	127.9	70.3	1.4
NORTHBOUND	LT 127+41.55	TO	LT 151+10.00	2,368.5	8.0	2,105.3	3.250	383.2	210.5	4.2
NORTHBOUND	LT 151+10.00	TO	LT 152+90.00	180.0	8.0	160.0	1.500	13.4	16.0	0.3
NORTHBOUND	LT 152+90.00	TO	LT 175+13.87	2,223.9	8.0	1,976.8	3.250	359.8	197.7	4.0
NORTHBOUND	LT 175+13.87	TO	LT 309+40.00	13,426.1	8.0	11,934.3	1.625	1,086.0	1,193.4	23.9
NORTHBOUND	LT 309+40.00	TO	LT 323+70.06	1,430.1	8.0	1,271.2	3.250	231.4	127.1	2.5
NORTHBOUND	LT 324+81.38	TO	LT 330+00.00	518.6	8.0	461.0	3.250	83.9	46.1	0.9
NORTHBOUND	LT 330+00.00	TO	LT 360+83.33 (BK)	3,083.3	8.0	2,740.7	1.625	249.4	274.1	5.5
NORTHBOUND	LT 360+87.35 (AH)	TO	LT 380+27.45	1,940.1	8.0	1,724.5	1.625	156.9	172.5	3.4
NORTHBOUND	LT 380+27.45	TO	LT 382+07.45	180.0	8.0	160.0	3.250	29.1	16.0	0.3
NORTHBOUND	LT 382+07.45	TO	LT 389+40.00	732.6	8.0	651.2	1.625	59.3	65.1	1.3
NORTHBOUND	LT 389+40.00	TO	LT 422+36.40	3,296.4	8.0	2,930.1	3.250	533.3	293.0	5.9
NORTHBOUND	LT 423+31.30	TO	LT 437+20.35	1,389.1	8.0	1,234.7	3.250	224.7	123.5	2.5
NORTHBOUND	LT 437+20.35	TO	LT 439+00.35	180.0	8.0	160.0	3.250	29.1	16.0	0.3
NORTHBOUND	LT 439+00.35	TO	LT 463+19.00	2,418.7	8.0	2,149.9	3.250	391.3	215.0	4.3
NORTHBOUND	LT 464+30.00	TO	LT 528+33.59	6,403.6	8.0	5,692.1	1.625	518.0	569.2	11.4
NORTHBOUND	LT 530+77.40	TO	LT 547+00.00	1,622.6	8.0	1,442.3	1.625	131.3	144.2	2.9
SUB-TOTALS =								15,699.6	11,785.0	235.7
NB RAMP TAPERS										
RAMP C	IL 133 375+46.98	TO	382+23.00	676.0	10.0	751.1	7.000	294.4	75.1	1.5
RAMP B	IL 133 241+23.00	TO	252+03.36	1,080.4	10.0	1,200.4	7.000	470.6	120.0	2.4
RAMP C	US 36 530+77.40 M.L.	TO	534+03.00 M.L.	325.6	10.0	361.8	1.625	32.9	36.2	0.7
RAMP C	US 36 534+03.00 M.L.	TO	200+85.00	128.0	10.0	142.2	1.625	12.9	14.2	0.3
RAMP D	US 36 318+00.00	TO	320+11.00	211.0	10.0	234.4	1.625	21.3	23.4	0.5
SUB-TOTALS =								832.2	269.0	5.4
NB GORE AREAS										
RAMP C	IL 133 1478+25.00	TO	1482+25.00	400.0	VAR	455.9	7.000	178.7	45.6	0.9
RAMP B	IL 133 1501+20.00	TO	1504+00.00	280.0	VAR	177.9	7.000	69.7	17.8	0.4
RAMP C	US 36 532+70.00	TO	535+42.00	272.0	VAR	315.3	1.625	28.7	31.5	0.6
RAMP D	US 36 544+92.00	TO	547+00.00	208.0	VAR	300.3	1.625	27.3	30.0	0.6
SUB-TOTALS =								304.5	124.9	2.5
SHEET TOTALS =								16,836.3	12,179.0	243.6

HOT MIX ASPHALT SHOULDERS, SPECIAL										
DESCRIPTION	STATION	TO	STATION	LENGTH (FOOT)	WIDTH (FOOT)	AREA (SQ YD)	AVERAGE SHOULDER THICKNESS (INCH)	48203105 HMA SHOULDERS, SPECIAL (TON)		
MAINLINE										
VARIOUS SPOT LOCATIONS										
SOUTHBOUND	LT 180+00.00	TO	LT 360+00.00	5,280.0	3.0	1,760.0	3.0			295.7
VARIOUS SPOT LOCATIONS										
SOUTHBOUND	LT 370+00.00	TO	LT 480+00.00	5,280.0	3.0	1,760.0	3.0			295.7
SUB-TOTAL =										591.4
IL 133 RAMPS										
RAMP A	RT 120+00.00	TO	RT 124+00.00	400.0	4.0	177.8	2.5			24.9
RAMP B	RT 238+00.00	TO	RT 240+00.00	200.0	4.0	88.9	2.5			12.4
RAMP C	RT 385+00.00	TO	RT 387+00.00	200.0	4.0	88.9	2.5			12.4
RAMP C	RT 388+00.00	TO	RT 390+00.00	200.0	4.0	88.9	2.5			12.4
RAMP D	RT 455+50.00	TO	RT 456+50.00	100.0	4.0	44.4	2.5			6.2
SUB-TOTAL =										68.4
TOTAL =										659.8
USE =										660.0

ILLINOIS DEPARTMENT OF TRANSPORTATION
SCHEDULE OF QUANTITIES
 F.A.I. ROUTE 57
 SECTION (15,21-25,21-26,27)RS-1
 DOUGLAS COUNTY
 SCALE: N/A
 DATE: 08-07-08
 DRAWN BY: RC
 CHECKED BY: KD

PLOT DATE = 8/21/2008
 FILE NAME = c:\p\proj\secta\d591385 (v81)76465cover.dgn
 PLOT SCALE = 1/8"=1'-0" / IN.
 USER NAME = sheehygm

F.A.I. RTE.	SECTION	COUNTY	TOTAL SHEETS	SHEET NO.
57	*	DOUGLAS	76	20

SCHEDULE OF QUANTITIES

SOUTHBOUND HOT MIX ASPHALT SHOULDERS												
DESCRIPTION	STATION	TO	STATION	LENGTH (FOOT)	WIDTH (FOOT)	AREA (SQ YD)	AVERAGE SHOULDER THICKNESS (INCH)	48203100 HMA SHOULDER (TON)	40600100 BIT MATLS PRIME COAT (GAL)	40600300 AGGREGATE PRIME COAT (TON)		
MAINLINE QUANTITIES												
SOUTHBOUND	RT	1386+81.00	TO RT	1387+81.00	90.0	12.0	120.0	1.500	10.1	12.0	0.2	
SOUTHBOUND	RT	1387+81.00	TO RT	1473+49.73	8,568.7	12.0	11,425.0	3.125	1,999.4	1,142.5	22.8	
SOUTHBOUND	RT	1483+84.00	TO RT	1491+86.53	802.5	12.0	1,070.0	3.125	187.3	107.0	2.1	
SOUTHBOUND	RT	1491+86.53	TO RT	1493+66.53	180.0	12.0	240.0	3.250	43.7	24.0	0.5	
SOUTHBOUND	RT	1493+66.53	TO RT	1502+92.00	925.5	12.0	1,234.0	3.125	215.9	123.4	2.5	
SOUTHBOUND	RT	117+29.40	TO RT	125+14.09	784.7	12.0	1,046.3	3.125	183.1	104.6	2.1	
SOUTHBOUND	RT	127+41.55	TO RT	151+10.00	2,368.5	12.0	3,157.9	3.125	552.6	315.8	6.3	
SOUTHBOUND	RT	151+10.00	TO RT	152+90.00	180.0	12.0	240.0	1.500	20.2	24.0	0.5	
SOUTHBOUND	RT	152+90.00	TO RT	175+13.87	2,223.9	12.0	2,965.2	3.125	518.9	296.5	5.9	
SOUTHBOUND	RT	175+13.87	TO RT	323+70.06	14,856.2	12.0	19,808.3	1.625	1,802.6	1,980.8	39.6	
SOUTHBOUND	RT	324+81.38	TO RT	360+83.33 (BK)	3,602.0	12.0	4,802.6	1.625	437.0	480.3	9.6	
SOUTHBOUND	RT	360+87.35 (AH)	TO RT	380+27.45	1,940.1	12.0	2,586.8	1.625	235.4	258.7	5.2	
SOUTHBOUND	RT	380+27.45	TO RT	382+07.45	180.0	12.0	240.0	3.250	43.7	24.0	0.5	
SOUTHBOUND	RT	382+07.45	TO RT	421+86.60	3,979.2	12.0	5,305.5	1.625	482.8	530.6	10.6	
SOUTHBOUND	RT	422+80.38	TO RT	437+20.35	1,440.0	12.0	1,920.0	1.625	174.7	192.0	3.8	
SOUTHBOUND	RT	437+20.35	TO RT	439+00.35	180.0	12.0	240.0	3.250	43.7	24.0	0.5	
SOUTHBOUND	RT	439+00.35	TO RT	463+69.00	2,468.7	12.0	3,291.5	1.625	299.5	329.2	6.6	
SOUTHBOUND	RT	464+82.00	TO RT	502+70.76	3,788.8	12.0	5,051.7	1.625	459.7	505.2	10.1	
SOUTHBOUND	RT	515+42.00	TO RT	523+15.00	773.0	12.0	1,030.7	1.625	93.8	103.1	2.1	
SOUTHBOUND	RT	530+78.85	TO RT	547+00.00	1,621.2	12.0	2,161.5	1.625	196.7	216.2	4.3	
SOUTHBOUND	LT	1386+81.00	TO LT	1387+81.00	90.0	8.0	80.0	1.500	6.7	8.0	0.2	
SOUTHBOUND	LT	1387+81.00	TO LT	1491+86.53	10,405.5	8.0	9,249.4	3.250	1,683.4	924.9	18.5	
SOUTHBOUND	LT	1491+86.53	TO LT	1493+66.53	180.0	8.0	160.0	3.250	29.1	16.0	0.3	
SOUTHBOUND	LT	1493+66.53	TO LT	1510+00.00 (BK)	1,633.5	8.0	1,452.0	3.250	264.3	145.2	2.9	
SOUTHBOUND	LT	117+23.47 (AH)	TO LT	125+14.09	790.6	8.0	702.8	3.250	127.9	70.3	1.4	
SOUTHBOUND	LT	127+41.55	TO LT	151+10.00	2,368.5	8.0	2,105.3	3.250	383.2	210.5	4.2	
SOUTHBOUND	LT	151+10.00	TO LT	152+90.00	180.0	8.0	160.0	1.500	13.4	16.0	0.3	
SOUTHBOUND	LT	152+90.00	TO LT	175+13.87	2,223.9	8.0	1,976.8	3.250	359.8	197.7	4.0	
SOUTHBOUND	LT	175+13.87	TO LT	323+70.06	14,856.2	8.0	13,205.5	1.625	1,201.7	1,320.6	26.4	
SOUTHBOUND	LT	324+81.38	TO LT	360+83.33 (BK)	3,602.0	8.0	3,201.7	1.625	291.4	320.2	6.4	
SOUTHBOUND	LT	360+87.35 (AH)	TO LT	380+27.45	1,940.1	8.0	1,724.5	1.625	156.9	172.5	3.4	
SOUTHBOUND	LT	380+27.45	TO LT	382+07.45	180.0	8.0	160.0	3.250	29.1	16.0	0.3	
SOUTHBOUND	LT	382+07.45	TO LT	421+86.60	3,979.2	8.0	3,537.0	1.625	321.9	353.7	7.1	
SOUTHBOUND	LT	422+80.38	TO LT	437+20.35	1,440.0	8.0	1,280.0	1.625	116.5	128.0	2.6	
SOUTHBOUND	LT	437+20.35	TO LT	439+00.35	180.0	8.0	160.0	3.250	29.1	16.0	0.3	
SOUTHBOUND	LT	439+00.35	TO LT	463+69.00	2,468.7	8.0	2,194.4	1.625	199.7	219.4	4.4	
SOUTHBOUND	LT	464+82.00	TO LT	528+35.17	6,353.2	8.0	5,647.3	1.625	513.9	564.7	11.3	
SOUTHBOUND	LT	530+78.85	TO LT	547+00.00	1,621.2	8.0	1,441.0	1.625	131.1	144.1	2.9	
								SUB-TOTAL =	13,859.8	11,637.4	232.7	
SB RAMP TAPERS												
RAMP D	IL 133	462+23.00	TO	472+50.28	1,027.3	10.0	1,141.4	7.000	447.4	114.1	2.3	
RAMP A	IL 133	109+94.49	TO	117+00.00	705.5	10.0	783.9	7.000	307.3	78.4	1.6	
RAMP A	US 36	016+92.00	TO	029+61.49	1,269.5	10.0	1,410.5	1.625	128.4	141.1	2.8	
RAMP B	US 36	101+54.00	TO	525+39.90 M.L.	223.9	10.0	248.8	1.625	22.6	24.9	0.5	
RAMP B	US 36	525+39.90 M.L.	TO	528+35.17 M.L.	295.3	10.0	328.1	1.625	29.9	32.8	0.7	
								SUB-TOTAL =	935.6	391.3	7.8	
SB GORE AREAS												
RAMP D	IL 133	1482+00.00	TO	1483+84.00	184.0	VAR	177.9	7.000	69.7	17.8	0.4	
RAMP A	IL 133	1502+92.00	TO	1507+33.00	441.0	VAR	586.8	7.000	230.0	58.7	1.2	
RAMP A	US 36	510+20.00	TO	515+42.00	522.0	VAR	416.3	1.625	37.9	41.6	0.8	
RAMP B	US 36	523+15.00	TO	526+50.00	335.0	VAR	383.4	1.625	34.9	38.3	0.8	
								SUB-TOTAL =	372.5	156.4	3.1	
								SHEET TOTALS =	15,167.9	12,185.2	243.7	

INTERCHANGE RAMP HOT MIX ASPHALT SHOULDERS												
DESCRIPTION	STATION	TO	STATION	LENGTH (FOOT)	WIDTH (FOOT)	AREA (SQ YD)	AVERAGE SHOULDER THICKNESS (INCH)	48203100 HMA SHOULDER (TON)	40600100 BIT MATLS PRIME COAT (GAL)	40600300 AGGREGATE PRIME COAT (TON)		
IL 133 RAMP												
RAMP A	RT	117+00.00	TO RT	129+67.74	1,267.7	10.0	1,408.6	2.25	177.5	140.9	2.8	
RAMP A	LT	117+00.00	TO LT	129+67.74	1,267.7	8.0	1,126.9	2.25	142.0	112.7	2.3	
RAMP B	RT	230+26.09	TO RT	241+23.00	1,096.9	10.0	1,218.8	2.25	153.6	121.9	2.4	
RAMP B	LT	230+26.09	TO LT	241+23.00	1,096.9	8.0	975.0	2.25	122.9	97.5	2.0	
RAMP C	RT	382+23.00	TO RT	395+20.80	1,297.8	10.0	1,442.0	2.25	181.7	144.2	2.9	
RAMP C	LT	382+23.00	TO LT	395+20.80	1,297.8	8.0	1,153.6	2.25	145.4	115.4	2.3	
RAMP D	RT	450+73.03	TO RT	462+23.00	1,150.0	10.0	1,277.7	2.25	161.0	127.8	2.6	
RAMP D	LT	450+73.03	TO LT	462+23.00	1,150.0	8.0	1,022.2	2.25	128.8	102.2	2.0	
								SUB-TOTAL =	1,212.7	962.5	19.2	
US 36 RAMP												
RAMP A	RT	0+33.00	TO RT	2+52.50	219.5	10.0	243.9	1.5	20.5	24.4	0.5	
RAMP A	RT	2+52.50	TO RT	16+92.00	1,439.5	10.0	1,599.4	2.25	201.5	159.9	3.2	
RAMP A	LT	0+80.00	TO LT	2+52.50	172.5	9.0	172.5	1.5	14.5	17.3	0.3	
RAMP A	LT	2+52.50	TO LT	16+92.00	1,439.5	9.0	1,439.5	2.25	181.4	144.0	2.9	
RAMP B	RT	101+54.00	TO RT	115+72.18	1,418.2	10.0	1,575.8	2.25	198.5	157.6	3.2	
RAMP B	RT	115+72.18	TO RT	117+91.68	219.5	10.0	243.9	1.5	20.5	24.4	0.5	
RAMP B	LT	101+54.00	TO LT	110+07.30	853.3	7.0	663.7	2.25	83.6	66.4	1.3	
RAMP B	LT	110+07.30	TO LT	115+72.18	564.9	9.0	564.9	2.25	71.2	56.5	1.1	
RAMP B	LT	115+72.18	TO LT	116+91.00	118.8	9.0	118.8	1.5	10.0	11.9	0.2	
RAMP C	RT	200+85.00	TO RT	215+66.73	1,481.7	10.0	1,646.4	2.25	207.4	164.6	3.3	
RAMP C	RT	215+66.73	TO RT	217+86.23	219.5	10.0	243.9	1.5	20.5	24.4	0.5	
RAMP C	LT	200+85.00	TO LT	215+66.73	1,481.7	9.0	1,481.7	2.25	186.7	148.2	3.0	
RAMP C	LT	215+66.73	TO LT	216+84.00	117.3	9.0	117.3	1.5	9.9	11.7	0.2	
RAMP D	RT	300+33.00	TO RT	302+52.50	219.5	10.0	243.9	1.5	20.5	24.4	0.5	
RAMP D	RT	302+52.50	TO RT	318+00.00	1,547.5	10.0	1,719.4	2.25	216.7	171.9	3.4	
RAMP D	LT	300+33.00	TO LT	302+52.50	167.5	7.0	130.3	1.5	10.9	13.0	0.3	
RAMP D	LT	302+52.50	TO LT	318+00.00	1,547.5	7.0	1,203.6	2.25	151.7	120.4	2.4	
								SUB-TOTAL =	1,625.9	1,340.9	26.8	
								INTERCHANGE RAMP TOTAL =	2,838.6	2,303.4	46.1	
								SHEET 19 NORTHBOUND TOTAL =	16,836.3	12,179.0	243.6	
								SHEET 20 SOUTHBOUND TOTAL =	15,167.9	12,185.2	243.7	
								TOTAL =	34,842.8	26,667.5	534.4	
								USE =	34,843.0	26,668.0	534.0	

ILLINOIS DEPARTMENT OF TRANSPORTATION
SCHEDULE OF QUANTITIES
 F.A.I. ROUTE 57
 SECTION (15,21-25,21-26,27)RS-1
 DOUGLAS COUNTY

SCALE: N/A
 DATE: 08-07-08

DRAWN BY: RC
 CHECKED BY: KD

F.A.I. RTE.	SECTION	COUNTY	TOTAL SHEETS	SHEET NO.
57	*	DOUGLAS	76	21

* (15,21-25,21-26,27)RS-1

SCHEDULE OF QUANTITIES

48101200 AGGREGATE SHOULDERS, TYPE B								
DESCRIPTION	STATION	TO	STATION	LENGTH (FOOT)	WIDTH (FOOT)	AREA (SQ YD)	AVERAGE THICKNESS (INCHES)	48101200 AGG SHLD TYPE B (TON)
IL 133 RAMPS								
RAMP A	RT 109+94.49	TO	RT 117+00.00	705.5	2.0	156.8	2.25	17.6
RAMP A	RT 117+00.00	TO	RT 125+00.00	800.0	4.0	355.6	3.625	64.4
RAMP A	RT 125+00.00	TO	RT 129+67.74	467.7	2.0	103.9	2.125	11.0
RAMP A	LT 117+00.00	TO	LT 129+67.74	1,267.7	2.0	281.7	2.125	29.9
RAMP B	RT 230+26.09	TO	RT 237+00.00	673.9	2.0	149.8	2.125	15.9
RAMP B	RT 237+00.00	TO	RT 241+23.00	423.0	4.0	188.0	2.625	24.7
RAMP B	RT 241+23.00	TO	RT 252+03.36	1,080.4	2.0	240.1	2.25	27.0
RAMP B	LT 230+26.09	TO	LT 241+23.00	1,096.9	2.0	243.8	2.125	25.9
RAMP C	RT 375+46.98	TO	RT 382+23.00	676.0	2.0	150.2	2.25	16.9
RAMP C	RT 382+23.00	TO	RT 384+00.00	177.0	2.0	39.3	2.125	4.2
RAMP C	RT 384+00.00	TO	RT 390+00.00	600.0	4.0	266.7	3.125	41.7
RAMP C	RT 390+00.00	TO	RT 395+20.80	520.8	2.0	115.7	2.125	12.3
RAMP C	LT 382+23.00	TO	LT 395+20.80	1,297.8	2.0	288.4	2.125	30.6
RAMP D	RT 450+73.03	TO	RT 455+00.00	427.0	2.0	94.9	2.125	10.1
RAMP D	RT 455+00.00	TO	RT 459+00.00	400.0	4.0	177.8	2.625	23.3
RAMP D	RT 459+00.00	TO	RT 462+23.00	323.0	2.0	71.8	2.125	7.6
RAMP D	RT 462+23.00	TO	RT 472+50.28	1,027.3	2.0	228.3	2.25	25.7
RAMP D	LT 450+73.03	TO	LT 462+23.00	1,150.0	2.0	255.5	2.125	27.2
SUB-TOTAL =								416.1

US 36 RAMPS								
DESCRIPTION	STATION	TO	STATION	LENGTH (FOOT)	WIDTH (FOOT)	AREA (SQ YD)	AVERAGE THICKNESS (INCHES)	48101200 AGG SHLD TYPE B (TON)
RAMP A	RT 2+52.50	TO	RT 29+61.49	2,709.0	2.0	602.0	2.125	64.0
RAMP A	LT 2+52.50	TO	LT 16+92.00	1,439.5	2.0	319.9	2.125	34.0
RAMP B	RT 528+35.17	TO	RT 101+54.00	519.2	2.0	115.4	1.875	10.8
RAMP B	RT 101+54.00	TO	RT 115+72.18	1,418.2	2.0	315.2	2.125	33.5
RAMP B	LT 101+54.00	TO	LT 115+72.18	1,418.2	2.0	315.2	2.125	33.5
RAMP C	RT 530+77.40	TO	RT 200+85.00	453.6	2.0	100.8	1.875	9.5
RAMP C	RT 200+85.00	TO	RT 215+66.73	1,481.7	3.0	493.9	2.125	52.5
RAMP C	LT 200+85.00	TO	LT 215+66.73	1,481.7	2.0	329.3	2.125	35.0
RAMP D	RT 302+52.50	TO	RT 320+06.48	1,754.0	2.0	389.8	2.125	41.4
RAMP D	LT 302+52.50	TO	LT 318+00.00	1,547.5	2.0	343.9	2.125	36.5
SUB-TOTAL =								350.6
TOTAL =								766.7
USE =								767.0

MEDIAN CROSSEVERS						
STATION	PROPOSED AREA (SQ YD)	40800010 BITUMINOUS MATERIALS PRIME COAT (GAL)	40800030 AGGREGATE PRIME COAT (TON)	40800050 INCIDENTAL HMA SURFACE (TON)	35101400 AGGREGATE BASE COURSE TYPE B (TON)	44001005 HMA SURFACE REMOVAL (SQ YD)
1431+00.00	156.3	15.6	0.3	26.3	18.2	135.0
142+80.00	156.3	15.6	0.3	24.1	6.4	0.0
293+93.00	156.3	15.6	0.3	13.1	6.4	0.0
478+54.00	156.3	15.6	0.3	26.3	16.5	135.0
TOTAL =		62.5	1.3	89.7	47.5	270.0
USE =		63.0	2.0	90.0	48.0	270.0

40600982 HOT-MIX ASPHALT SURFACE REMOVAL - BUTT JOINT					
LOCATION	STATION	TO	STATION	WIDTH (FOOT)	AREA (SQ YD)
MAINLINE QUANTITIES					
BEGINNING OF SECTION					
NORTHBOUND	1387+81.00	TO	1389+91.00	31.0	723.3
UNDER SN 021-0024					
NORTHBOUND	1490+21.53	TO	1491+86.53	31.0	568.3
NORTHBOUND	1493+66.53	TO	1495+31.53	31.0	568.3
SN 021-0001					
NORTHBOUND	124+69.09	TO	125+14.09	44.0	220.0
NORTHBOUND	127+41.55	TO	127+86.55	44.0	220.0
UNDER SN 021-0041					
NORTHBOUND	149+00.00	TO	151+10.00	31.0	723.3
NORTHBOUND	152+90.00	TO	155+00.00	31.0	723.3
SN 021-0003					
NORTHBOUND	322+20.06	TO	323+70.06	31.0	516.7
NORTHBOUND	324+81.38	TO	326+31.38	31.0	516.7
SN 021-0006					
NORTHBOUND	420+86.40	TO	422+36.40	31.0	516.7
NORTHBOUND	423+31.30	TO	424+81.30	31.0	516.7
SN 021-0007					
NORTHBOUND	461+69.00	TO	463+19.00	31.0	516.7
NORTHBOUND	464+30.00	TO	465+72.50	31.0	490.8
SN 021-0009					
NORTHBOUND	527+81.09	TO	528+33.59	44.0	256.7
NORTHBOUND	530+77.40	TO	531+29.90	VAR	303.3
END OF SECTION					
NORTHBOUND	547+00.00	TO	547+52.50	VAR	361.7
BEGINNING OF SECTION					
SOUTHBOUND	1387+81.00	TO	1389+91.00	31.0	723.3
SN 021-0002					
SOUTHBOUND	124+69.09	TO	125+14.09	44.0	220.0
SOUTHBOUND	127+41.55	TO	127+86.55	44.0	220.0
UNDER SN 021-0041					
SOUTHBOUND	149+00.00	TO	151+10.00	31.0	723.3
SOUTHBOUND	152+90.00	TO	155+00.00	31.0	723.3
SN 021-0004					
SOUTHBOUND	322+80.06	TO	323+70.06	31.0	310.0
SOUTHBOUND	324+81.38	TO	325+71.38	31.0	310.0
SN 021-0005					
SOUTHBOUND	420+86.60	TO	421+86.60	31.0	310.0
SOUTHBOUND	422+80.38	TO	423+70.38	31.0	310.0
SN 021-0008					
SOUTHBOUND	462+79.00	TO	463+69.00	31.0	310.0
SOUTHBOUND	464+82.00	TO	466+24.50	31.0	490.8
SN 021-0010					
SOUTHBOUND	527+82.67	TO	528+35.17	VAR	303.3
SOUTHBOUND	530+78.85	TO	531+31.35	44.0	256.7
END OF SECTION					
SOUTHBOUND	547+00.00	TO	547+52.50	44.0	256.7
MAINLINE TOTAL =					13,210.0

RAMP QUANTITIES					
DESCRIPTION	STATION	TO	STATION	WIDTH (FOOT)	AREA (SQ YD)
IL133 RAMP A	129+42.74	TO	129+67.74	VAR	284.7
IL133 RAMP B	230+26.09	TO	230+51.09	VAR	309.0
IL133 RAMP C	394+95.80	TO	395+20.80	VAR	290.0
IL133 RAMP D	450+98.03	TO	450+98.03	VAR	270.9
US36 RAMP A	0+33.00	TO	2+30.00	VAR	1,085.9
US36 RAMP B	115+94.68	TO	117+91.68	VAR	1,109.6
US36 RAMP C	215+89.23	TO	217+86.23	VAR	1,117.9
US36 RAMP D	300+33.00	TO	302+30.00	VAR	1,104.8
RAMP TOTALS =					5,572.7
TOTAL =					18,782.7
USE =					18,783.0

40600985 PORTLAND CEMENT CONCRETE SURFACE REMOVAL - BUTT JOINT					
LOCATION	STATION	TO	STATION	WIDTH (FOOT)	AREA (SQ YD)
NORTHBOUND	1387+81.00	TO	1388+26.00	24.0	120.0
NORTHBOUND	150+65.00	TO	151+10.00	24.0	120.0
NORTHBOUND	152+90.00	TO	153+35.00	24.0	120.0
SOUTHBOUND	1387+81.00	TO	1388+26.00	24.0	120.0
SOUTHBOUND	150+65.00	TO	151+10.00	24.0	120.0
SOUTHBOUND	152+90.00	TO	153+35.00	24.0	120.0
TOTAL =					720.0
USE =					720.0

ILLINOIS DEPARTMENT OF TRANSPORTATION
SCHEDULE OF QUANTITIES
 F.A.I. ROUTE 57
 SECTION (15,21-25,21-26,27)RS-1
 DOUGLAS COUNTY

SCALE: N/A
 DATE: 08-07-08
 DRAWN BY: RC
 CHECKED BY: KD

PLOT DATE = 8/21/2008
 FILE NAME = c:\p\projects\48101200 (v81)\70465\cover.dgn
 PLOT SCALE = 1/8"=1'-0"
 USER NAME = sheehyjm

F.A.I. RTE.	SECTION	COUNTY	TOTAL SHEETS	SHEET NO.
57	*	DOUGLAS	76	22

* (15,21-25,21-26,27)RS-1

SCHEDULE OF QUANTITIES

40600990 TEMPORARY RAMP						
LOCATION	STATION	TO	STATION	WIDTH (FOOT)	AREA (SQ YD)	
MAINLINE QUANTITIES						
BEGINNING OF SECTION						
NORTHBOUND	1387+81.00	TO	1387+96.00	44.0	73.3	
UNDER SN 021-0024						
NORTHBOUND	1491+71.53	TO	1491+86.53	44.0	73.3	
NORTHBOUND	1493+66.53	TO	1493+81.53	44.0	73.3	
SN 021-0001						
NORTHBOUND	124+99.09	TO	125+14.09	44.0	73.3	
NORTHBOUND	127+41.55	TO	127+56.55	44.0	73.3	
UNDER SN 021-0041						
NORTHBOUND	150+95.00	TO	151+10.00	44.0	73.3	
NORTHBOUND	152+90.00	TO	153+05.00	44.0	73.3	
SN 021-0003						
NORTHBOUND	323+50.06	TO	323+70.06	44.0	97.8	
NORTHBOUND	323+57.56	TO	323+70.06	44.0	61.1	
NORTHBOUND	324+81.38	TO	325+01.38	44.0	97.8	
NORTHBOUND	324+81.38	TO	324+93.88	44.0	61.1	
SN 021-0006						
NORTHBOUND	422+16.40	TO	422+36.40	44.0	97.8	
NORTHBOUND	422+23.90	TO	422+36.40	44.0	61.1	
NORTHBOUND	423+31.30	TO	423+51.30	44.0	97.8	
NORTHBOUND	423+31.30	TO	423+43.80	44.0	61.1	
SN 021-0007						
NORTHBOUND	462+99.00	TO	463+19.00	44.0	97.8	
NORTHBOUND	463+06.50	TO	463+19.00	44.0	61.1	
NORTHBOUND	464+30.00	TO	464+47.50	44.0	85.6	
SN 021-0009						
NORTHBOUND	528+16.09	TO	528+33.59	44.0	85.6	
NORTHBOUND	530+77.40	TO	530+94.90	VAR	105.0	
END OF SECTION						
NORTHBOUND	547+35.00	TO	547+52.50	VAR	120.6	
BEGINNING OF SECTION						
SOUTHBOUND	1387+81.00	TO	1387+96.00	44.0	73.3	
SN 021-0002						
SOUTHBOUND	124+99.09	TO	125+14.09	44.0	73.3	
SOUTHBOUND	127+41.55	TO	127+56.55	44.0	73.3	
SN 021-0041						
SOUTHBOUND	150+95.00	TO	151+10.00	44.0	73.3	
SOUTHBOUND	152+90.00	TO	153+05.00	44.0	73.3	
SN 021-0004						
SOUTHBOUND	323+52.56	TO	323+70.06	44.0	85.6	
SOUTHBOUND	324+81.38	TO	324+98.88	44.0	85.6	
SN 021-0005						
SOUTHBOUND	421+69.10	TO	421+86.60	44.0	85.6	
SOUTHBOUND	422+80.38	TO	422+97.88	44.0	85.6	
SN 021-0008						
SOUTHBOUND	463+51.50	TO	463+69.00	44.0	85.6	
SOUTHBOUND	464+82.00	TO	464+99.50	44.0	85.6	
SN 021-0010						
SOUTHBOUND	528+17.67	TO	528+35.17	VAR	105.0	
SOUTHBOUND	530+78.85	TO	530+96.35	44.0	85.6	
END OF SECTION						
SOUTHBOUND	547+35.00	TO	547+52.50	44.0	85.6	
					MAINLINE TOTAL =	2,860.6

RAMP QUANTITIES						
IL133 RAMP A	116+85.00	TO	117+00.00	26.0	43.3	
IL133 RAMP A	129+56.07	TO	129+67.74	VAR	165.9	
IL133 RAMP B	230+26.09	TO	230+37.76	VAR	147.3	
IL133 RAMP B	241+23.00	TO	241+38.00	26.0	43.3	
IL133 RAMP C	382+08.00	TO	382+23.00	26.0	43.3	
IL133 RAMP C	395+09.13	TO	395+20.80	VAR	171.2	
IL133 RAMP D	450+73.03	TO	450+84.70	VAR	138.7	
IL133 RAMP D	462+23.00	TO	462+38.00	26.0	43.3	
US36 RAMP A	0+33.00	TO	0+38.00	VAR	60.3	
US36 RAMP B	117+86.68	TO	117+91.68	VAR	102.2	
US36 RAMP C	217+81.23	TO	217+86.23	VAR	78.9	
US36 RAMP D	300+33.00	TO	300+38.00	VAR	60.3	
					RAMP TOTALS =	1,098.1
					TOTAL =	3,958.6
					USE =	3,959.0

44000155 HOT-MIX ASPHALT SURFACE REMOVAL 1 1/2"						
LOCATION	STATION	TO	STATION	WIDTH (FOOT)	AREA (SQ YD)	
UNDER SN 015-0063						
N.B. SHOULDER (OUT)	1386+91.00	TO	1387+81.00	12.0	120.0	
N.B. SHOULDER (MED)	1386+91.00	TO	1387+81.00	5.0	50.0	
UNDER SN 021-0024						
N.B. SHOULDER (OUT)	1491+86.53	TO	1493+66.53	12.0	240.0	
N.B. SHOULDER (MED)	1491+86.53	TO	1493+66.53	8.0	160.0	
UNDER SN 021-0041						
N.B. SHOULDER (OUT)	151+10.00	TO	152+90.00	12.0	240.0	
N.B. SHOULDER (MED)	151+10.00	TO	152+90.00	8.0	160.0	
UNDER SN 015-0063						
S.B. SHOULDER (OUT)	1386+91.00	TO	1387+81.00	12.0	120.0	
S.B. SHOULDER (MED)	1386+91.00	TO	1387+81.00	4.0	40.0	
UNDER SN 021-0041						
S.B. SHOULDER (OUT)	151+10.00	TO	152+90.00	12.0	240.0	
S.B. SHOULDER (MED)	151+10.00	TO	151+72.00	8.0	55.1	
S.B. SHOULDER (MED)	151+95.00	TO	152+16.00	8.0	18.7	
S.B. SHOULDER (MED)	152+71.00	TO	152+90.00	8.0	16.9	
					TOTAL =	1,460.7
					USE =	1,461.0

44000162 HOT-MIX ASPHALT SURFACE REMOVAL 3 1/4"						
LOCATION	STATION	TO	STATION	WIDTH (FOOT)	AREA (SQ YD)	
N.B. DRIVING LANE	1387+81.00	TO	1491+86.53	13.0	15,030.2	
N.B. DRIVING LANE	1493+66.53	TO	1510+00.00 (BK)	13.0	2,359.5	
N.B. DRIVING LANE	117+23.47 (AH)	TO	122+65.81	13.0	783.4	
N.B. DRIVING LANE	129+62.99	TO	151+10.00	13.0	3,101.2	
N.B. DRIVING LANE	152+90.00	TO	323+70.06	13.0	24,671.2	
N.B. DRIVING LANE	324+81.38	TO	360+83.33 (BK)	13.0	5,202.8	
N.B. DRIVING LANE	360+87.35 (AH)	TO	422+36.40	13.0	8,882.0	
N.B. DRIVING LANE	423+31.30	TO	463+19.00	13.0	5,760.0	
N.B. DRIVING LANE	524+70.00	TO	525+41.80	13.0	103.7	
N.B. DRIVING LANE	534+03.00	TO	547+00.00	13.0	1,873.4	
S.B. DRIVING LANE	1387+81.00	TO	1510+00.00 (BK)	13.0	17,649.7	
S.B. DRIVING LANE	117+23.47 (AH)	TO	122+65.81	13.0	783.4	
S.B. DRIVING LANE	129+62.99	TO	151+10.00	13.0	3,101.2	
S.B. DRIVING LANE	152+90.00	TO	323+70.06	13.0	24,671.2	
S.B. DRIVING LANE	324+81.38	TO	360+83.33 (BK)	13.0	5,202.8	
S.B. DRIVING LANE	360+87.35 (AH)	TO	421+86.60	13.0	8,810.0	
S.B. DRIVING LANE	422+80.38	TO	463+69.00	13.0	5,905.8	
S.B. DRIVING LANE	524+70.00	TO	525+39.90	13.0	101.0	
S.B. DRIVING LANE	534+03.00	TO	547+00.00	13.0	1,873.4	
					MAINLINE TOTAL =	135,865.9

RAMP QUANTITIES						
IL133 RAMP A	109+94.49	TO	117+00.00	VAR	1024.7	
IL133 RAMP A (SHOULDER)	109+94.49	TO	117+00.00	10.0	783.9	
IL133 RAMP A (GORE)	1502+92.00	TO	1507+33.00	VAR	586.8	
IL133 RAMP B	241+23.00	TO	252+03.36	VAR	1248.2	
IL133 RAMP B (SHOULDER)	241+23.00	TO	246+33.00	10.0	566.7	
IL133 RAMP B (GORE)	1501+20.00	TO	1504+00.00	VAR	177.9	
IL133 RAMP C	375+46.98	TO	382+23.00	VAR	943.0	
IL133 RAMP C (SHOULDER)	375+46.98	TO	382+23.00	10.0	751.1	
IL133 RAMP C (GORE)	1478+25.00	TO	1482+25.00	VAR	455.9	
IL133 RAMP D	462+23.00	TO	472+50.28	VAR	1153.2	
IL133 RAMP D (SHOULDER)	462+23.00	TO	472+50.28	10.0	114.4	
IL133 RAMP D (GORE)	1482+00.00	TO	1483+84.00	VAR	177.9	
					RAMP TOTALS =	9,010.8
					TOTAL =	144,876.7
					USE =	144,877.0

44000169 HOT-MIX ASPHALT SURFACE REMOVAL 5"						
LOCATION	STATION	TO	STATION	WIDTH (FOOT)	AREA (SQ YD)	
N.B. DRIVING LANE	464+30.00	TO	524+70.00	13.0	8,724.4	
S.B. DRIVING LANE	464+82.00	TO	524+70.00	13.0	8,649.3	
					TOTAL =	17,373.8
					USE =	17,374.0

PLOT DATE = 8/21/2008
 FILE NAME = c:\p\projects\4591385 (v8)\78465cover.dgn
 PLOT SCALE = 1/8"=1'-0"
 USER NAME = sheehyjm

ILLINOIS DEPARTMENT OF TRANSPORTATION
SCHEDULE OF QUANTITIES
 F.A.I. ROUTE 57
 SECTION (15,21-25,21-26,27)RS-1
 DOUGLAS COUNTY
 SCALE: N/A
 DATE: 08-07-08
 DRAWN BY: RC
 CHECKED BY: JD

F.A.I. RTE.	SECTION	COUNTY	TOTAL SHEETS	SHEET NO.
57	*	DOUGLAS	76	23

* (15,21-25,21-26,27)RS-1

SCHEDULE OF QUANTITIES

44000198 HOT-MIX ASPHALT SURFACE REMOVAL, VARIABLE DEPTH					
LOCATION	STATION	TO	STATION	WIDTH (FOOT)	AREA (SQ YD)
MAINLINE					
N.B. PASSING LANE	175+13.87	TO	310+00.00	11.0	16,483.0
N.B. PASSING LANE	330+00.00	TO	360+83.33 (BK)	11.0	3,768.5
N.B. PASSING LANE	360+87.35 (AH)	TO	379+74.95	11.0	2,307.1
MAINLINE UNDER SN 021-0046					
N.B. PL, MED & OUT SHLD	379+74.95	TO	382+59.95	31.0	981.7
MAINLINE					
N.B. PASSING LANE	382+59.95	TO	390+00.00	11.0	904.5
MAINLINE UNDER SN 021-0045					
N.B. PL, MED & OUT SHLD	436+22.85	TO	439+97.85	31.0	1,291.7
MAINLINE					
N.B. PASSING LANE	465+72.50	TO	527+81.09	11.0	7,588.3
N.B. PASSING LANE	531+29.90	TO	547+00.00	11.0	1,919.0
UNDER SN 021-0024					
S.B. PL, MED & OUT SHLD	1490+89.03	TO	1494+64.03	31.0	1,291.7
MAINLINE					
S.B. PASSING LANE	175+13.87	TO	322+80.06	11.0	18,047.6
S.B. PASSING LANE	325+71.38	TO	360+83.33 (BK)	11.0	4,292.4
S.B. PASSING LANE	360+87.35 (AH)	TO	379+74.95	11.0	2,307.1
UNDER SN 021-0046					
S.B. PL, MED & OUT SHLD	379+74.95	TO	382+59.95	31.0	981.7
MAINLINE					
S.B. PASSING LANE	382+59.95	TO	420+96.60	11.0	4,689.2
S.B. PASSING LANE	423+70.38	TO	436+67.85	11.0	1,585.8
UNDER SN 021-0045					
S.B. PL, MED & OUT SHLD	436+67.85	TO	439+52.85	31.0	981.7
MAINLINE					
S.B. PASSING LANE	439+52.35	TO	462+79.00	11.0	2,843.7
S.B. PASSING LANE	466+24.50	TO	527+82.67	11.0	7,526.7
S.B. PASSING LANE	531+31.35	TO	547+00.00	11.0	1,917.2
					TOTAL = 81,708.4
					USE = 81,709.0

X0325285 PORTLAND CEMENT CONCRETE SURFACE REMOVAL 1 1/2"					
LOCATION	STATION	TO	STATION	WIDTH (FOOT)	AREA (SQ YD)
UNDER SN 015-0063					
N.B. SHOULDER (MED)	1386+91.00	TO	1387+81.00	3.0	30.0
S.B. SHOULDER (MED)	1386+91.00	TO	1387+81.00	4.0	40.0
UNDER SN 021-0041					
S.B. SHOULDER (MED)	151+72.00	TO	151+95.00	8.0	20.4
S.B. SHOULDER (MED)	152+16.00	TO	152+71.00	8.0	48.9
					TOTAL = 139.3
					USE = 140.0

60300105 FRAMES AND GRATES TO BE ADJUSTED		
LOCATION	STATION	EACH
US 36 RAMP A GORE AREA	512+32.00	1.0
		TOTAL = 1.0

64200105 SHOULDER RUMBLE STRIP					
LOCATION	STATION	TO	STATION	LENGTH (FOOT)	
NORTHBOUND	RT 1386+91.00	TO	RT 1475+46.98	8,856.0	
NORTHBOUND	RT 1482+23.00	TO	RT 1501+15.00	1,892.0	
NORTHBOUND	RT 119+26.82	TO	RT 125+14.09	587.3	
NORTHBOUND	RT 127+41.55	TO	RT 323+70.06	19,628.5	
NORTHBOUND	RT 324+81.38	TO	RT 360+83.33 (BK)	3,602.0	
NORTHBOUND	RT 360+87.35 (AH)	TO	RT 422+38.00	6,150.7	
NORTHBOUND	RT 423+33.00	TO	RT 463+07.00	3,974.0	
NORTHBOUND	RT 464+30.00	TO	RT 528+33.59	6,403.6	
NORTHBOUND	RT 535+38.00	TO	RT 544+92.00	954.0	
NORTHBOUND	LT 1386+91.00	TO	LT 1430+70.00	4,379.0	
NORTHBOUND	LT 1431+30.00	TO	LT 1510+00.00 (BK)	7,870.0	
NORTHBOUND	LT 117+23.47 (AH)	TO	LT 125+14.09	790.6	
NORTHBOUND	LT 127+41.55	TO	LT 142+90.00	1,548.5	
NORTHBOUND	LT 143+50.00	TO	LT 293+63.00	15,013.0	
NORTHBOUND	LT 294+23.00	TO	LT 323+70.06	2,947.1	
NORTHBOUND	LT 324+81.38	TO	LT 360+83.33 (BK)	3,602.0	
NORTHBOUND	LT 360+87.35 (AH)	TO	LT 422+34.00	6,146.7	
NORTHBOUND	LT 423+29.00	TO	LT 463+23.00	3,994.0	
NORTHBOUND	LT 464+38.00	TO	LT 478+24.00	1,386.0	
NORTHBOUND	LT 478+84.00	TO	LT 528+33.59	4,949.6	
NORTHBOUND	LT 530+77.40	TO	LT 547+00.00	1,622.6	
SOUTHBOUND	RT 1386+91.00	TO	RT 1473+49.73	8,658.7	
SOUTHBOUND	RT 1483+85.00	TO	RT 1502+93.00	1,908.0	
SOUTHBOUND	RT 117+29.54	TO	RT 125+14.09	784.5	
SOUTHBOUND	RT 127+41.55	TO	RT 323+70.06	19,628.5	
SOUTHBOUND	RT 324+81.38	TO	RT 360+83.33 (BK)	3,602.0	
SOUTHBOUND	RT 360+87.35 (AH)	TO	RT 421+83.00	6,095.7	
SOUTHBOUND	RT 422+78.00	TO	RT 463+70.00	4,092.0	
SOUTHBOUND	RT 464+92.00	TO	RT 502+70.76	3,778.8	
SOUTHBOUND	RT 515+46.00	TO	RT 523+15.00	769.0	
SOUTHBOUND	RT 530+77.40	TO	RT 547+00.00	1,622.6	
SOUTHBOUND	LT 1386+91.00	TO	LT 1430+70.00	4,379.0	
SOUTHBOUND	LT 1431+30.00	TO	LT 1510+00.00 (BK)	7,870.0	
SOUTHBOUND	LT 117+23.47 (AH)	TO	LT 125+14.09	790.6	
SOUTHBOUND	LT 127+41.55	TO	LT 142+90.00	1,548.5	
SOUTHBOUND	LT 143+50.00	TO	LT 293+63.00	15,013.0	
SOUTHBOUND	LT 294+23.00	TO	LT 323+70.06	2,947.1	
SOUTHBOUND	LT 324+81.38	TO	LT 360+83.33 (BK)	3,602.0	
SOUTHBOUND	LT 360+87.35 (AH)	TO	LT 421+89.00	6,101.7	
SOUTHBOUND	LT 422+84.00	TO	LT 463+53.00	4,069.0	
SOUTHBOUND	LT 464+77.00	TO	LT 478+24.00	1,347.0	
SOUTHBOUND	LT 478+84.00	TO	LT 528+33.59	4,949.6	
SOUTHBOUND	LT 530+77.40	TO	LT 547+00.00	1,622.6	
					TOTAL = 211,476.5
					USE = 211,477.0

PLOT DATE = 8/21/2008
 FILE NAME = c:\p\projects\45901385 (v8)\78465\cover.dgn
 PLOT SCALE = 1/8"=1'-0"
 USER NAME = sheehycm

ILLINOIS DEPARTMENT OF TRANSPORTATION
SCHEDULE OF QUANTITIES
 F.A.I. ROUTE 57
 SECTION (15,21-25,21-26,27)RS-1
 DOUGLAS COUNTY

SCALE: N/A
 DATE: 08-07-08

DRAWN BY: RC
 CHECKED BY: KD

F.A.I. RTE.	SECTION	COUNTY	TOTAL SHEETS	SHEET NO.
57	*	DOUGLAS	76	24

* (15,21-25,21-26,27)RS-1

SCHEDULE OF QUANTITIES

78008310 POLYUREA PAVEMENT MARKING TYPE II- LINE 4"					
LOCATION	STATION	TO	STATION	LENGTH FOOT	
WHITE					
NORTHBOUND	RT 1386+91.00	TO	RT 1387+81.00	90.0	
NORTHBOUND	RT 1491+86.53	TO	RT 1493+66.53	180.0	
NORTHBOUND	RT 125+14.09	TO	RT 127+41.55	227.5	
NORTHBOUND	RT 151+10.00	TO	RT 152+90.00	180.0	
NORTHBOUND	RT 323+70.06	TO	RT 324+81.38	111.3	
NORTHBOUND	RT 422+36.40	TO	RT 423+31.30	94.9	
NORTHBOUND	RT 463+19.00	TO	RT 464+30.00	111.0	
NORTHBOUND	RT 528+33.59	TO	RT 530+77.40	243.8	
NORTHBOUND	RT 1386+91.00	TO	RT 1387+81.00	90.0	
SOUTHBOUND	RT 125+14.09	TO	RT 127+41.55	227.5	
SOUTHBOUND	RT 151+10.00	TO	RT 152+90.00	180.0	
SOUTHBOUND	RT 323+70.06	TO	RT 324+81.38	111.3	
SOUTHBOUND	RT 421+86.60	TO	RT 422+80.38	93.8	
SOUTHBOUND	RT 463+69.00	TO	RT 464+82.00	113.0	
SOUTHBOUND	RT 528+35.17	TO	RT 530+78.85	243.7	
SUB-				2297.7	

YELLOW					
NORTHBOUND	LT 1386+91.00	TO	LT 1387+81.00	90.0	
NORTHBOUND	LT 1491+86.53	TO	LT 1493+66.53	180.0	
NORTHBOUND	LT 125+14.09	TO	LT 127+41.55	227.5	
NORTHBOUND	LT 151+10.00	TO	LT 152+90.00	180.0	
NORTHBOUND	LT 323+70.06	TO	LT 324+81.38	111.3	
NORTHBOUND	LT 422+36.40	TO	LT 423+31.30	94.9	
NORTHBOUND	LT 463+19.00	TO	LT 464+30.00	111.0	
NORTHBOUND	LT 528+33.59	TO	LT 530+77.40	243.8	
SOUTHBOUND	LT 1386+91.00	TO	LT 1387+81.00	90.0	
SOUTHBOUND	LT 125+14.09	TO	LT 127+41.55	227.5	
SOUTHBOUND	LT 151+10.00	TO	LT 152+90.00	180.0	
SOUTHBOUND	LT 323+70.06	TO	LT 324+81.38	111.3	
SOUTHBOUND	LT 421+86.60	TO	LT 422+80.38	93.8	
SOUTHBOUND	LT 463+69.00	TO	LT 464+82.00	113.0	
SOUTHBOUND	LT 528+35.17	TO	LT 530+78.85	243.7	
SUB-				2297.7	
TOTAL =				4595.5	
USE =				4596.0	

78000400 THERMOPLASTIC PAVEMENT MARKING LINE - 6" (WHITE)					
LOCATION	STATION	TO	STATION	LENGTH (FOOT)	
ILL 133 INTERCHANGE					
RAMP A	129+39.00	TO	129+67.74	138.0	
RAMP C	394+90.00	TO	395+20.80	131.0	
US 36 INTERCHANGE					
RAMP B	129+67.74	TO	129+67.74	137.0	
RAMP C	129+67.74	TO	129+67.74	151.0	
TOTAL =				557.0	
USE =				557.0	

78000500 THERMOPLASTIC PAVEMENT MARKING LINE - 8" (WHITE)					
LOCATION	STATION	TO	STATION	LENGTH (FOOT)	
ILL 133 GORE AREAS					
NORTHBOUND	1478+25.00 (I-57)	TO	1482+25.00 (I-57)	400.0	
RAMP C	378+25.00	TO	382+25.00	400.0	
NORTHBOUND	1501+25.00 (I-57)	TO	1504+50.00 (I-57)	325.0	
RAMP B	241+25.00	TO	244+50.00	325.0	
SOUTHBOUND	1481+00.00 (I-57)	TO	1484+25.00 (I-57)	325.0	
RAMP D	461+75.00	TO	465+00.00	325.0	
SOUTHBOUND	1503+22.00 (I-57)	TO	1507+22.00 (I-57)	400.0	
RAMP A	112+78.00	TO	116+78.00	400.0	
SUB-TOTAL =				2,900.0	
US 36 GORE AREAS					
NORTHBOUND	532+00.00 (I-57)	TO	535+75.00 (I-57)	375.0	
RAMP C	532+00.00	TO	201+29.00	375.0	
NORTHBOUND	545+25.00 (I-57)	TO	550+00.00 (I-57)	475.0	
RAMP D	318+36.00	TO	550+00.00	475.0	
SOUTHBOUND	510+20.00 (I-57)	TO	515+20.00 (I-57)	500.0	
RAMP A	17+20.00	TO	22+20.00	500.0	
SOUTHBOUND	523+25.00 (I-57)	TO	527+00.00 (I-57)	375.0	
RAMP B	527+00.00	TO	101+45.00	375.0	
SUB-TOTAL =				3,450.0	
TOTAL =				6,350.0	
USE =				6,350.0	

78000600 THERMOPLASTIC PAVEMENT MARKING LINE - 12" (WHITE)					
LOCATION	STATION	TO	STATION	LENGTH (FOOT)	
ILL 133 INTERCHANGE					
RAMP A	129+54.00	TO	129+64.00	59.0	
RAMP C	395+08.00	TO	395+18.00	56.0	
US 36 INTERCHANGE					
RAMP B	117+77.00	TO	117+85.00	50.0	
RAMP C	217+77.00	TO	217+85.00	55.0	
TOTAL =				220.0	
USE =				220.0	

78000650 THERMOPLASTIC PAVEMENT MARKING LINE - 24" (WHITE)				
LOCATION	STATION	TO	STATION	LENGTH FOOT
ILL 133 INTERCHANGE				
RAMP A	RT 129+53.00			18.0
RAMP A	LT 129+53.00			18.0
RAMP C	RT 395+05.00			18.0
RAMP C	LT 395+05.00			18.0
US 36 INTERCHANGE				
RAMP B	RT 117+75.00			21.0
RAMP B	LT 117+75.00			18.0
RAMP C	RT 217+55.00			16.0
RAMP C	LT 217+55.00			18.0
TOTAL =				145.0
USE =				145.0

X0301741 AERIAL SPEED CHECK MARKINGS MARKING				
LOCATION	APPROXIMATE STATION	LOCATION	EACH DASH FOOT	LENGTH FOOT
NORTHBOUND				
MILE MARKER 202.5	1442+00.00	RT,CL,LT	4.0	12.0
MILE MARKER 202.5	1448+60.00	RT,CL,LT	4.0	12.0
MILE MARKER 202.5	1455+20.00	RT,CL,LT	4.0	12.0
SOUTHBOUND				
MILE MARKER 205.0	167+20.00	RT,CL,LT	4.0	12.0
MILE MARKER 205.0	173+80.00	RT,CL,LT	4.0	12.0
MILE MARKER 205.0	180+40.00	RT,CL,LT	4.0	12.0
TOTAL				72.0
USE =				72.0

PAVEMENT MARKINGS

QUANTITIES OUTSIDE THE LIMITS OF THIS SECTION ARE INCLUDED IN THE QUANTITIES LISTED

LOCATION	STATION	TO	STATION	78000200 THERMO PLASTIC PVT MKG 4" WHITE (FOOT)	78000200 THERMO PLASTIC PVT MKG 4" YELLOW (FOOT)	78003110 PREFORMED PLASTIC TYPE B 4" WHITE (FOOT)	78100100 RAISED REFLECTIVE PAVEMENT MARKERS CRYSTAL (EACH)	78100100 RAISED REFLECTIVE PAVEMENT MARKERS AMBER (EACH)
MAINLINE	1386+91.00	TO	547+00.00	103,409.0	108,618.0	27,093.0	1,355.0	0.0
ILL 133 RAMPS				8,302.0	4,787.0	0.0	111.0	32.0
US 36 RAMPS				8,480.0	6,492.0	0.0	91.0	44.0
TOTAL =				120,191.0	119,897.0	27,093.0	1,557.0	76.0
USE =				120,191.0	119,897.0	27,093.0	1,557.0	76.0

ILLINOIS DEPARTMENT OF TRANSPORTATION

SCHEDULE OF QUANTITIES

F.A.I. ROUTE 57
SECTION (15,21-25,21-26,27)RS-1
DOUGLAS COUNTY

SCALE: N/A
DATE: 08-07-08

DRAWN BY: RC
CHECKED BY: KD

F.A.I. RTE.	SECTION	COUNTY	TOTAL SHEETS	SHEET NO.
57	*	DOUGLAS	76	25

* (15,21-25,21-26,27)RS-1

SCHEDULE OF QUANTITIES

CLASS A PATCHES

STATION	DIRECTION	LANE	LENGTH (FOOT)	WIDTH (FOOT)	PATCH AREA		SAW CUTS 44213200 (FOOT)	TIE BARS Z0075300 (FOOT)	PATCHING REINFORCEMENT 44213000 (SQ YD)
					TYPE I, 12.0" 44200573 (SQ YD)	TYPE II, 12.0" 44200577 (SQ YD)			
465+64.87	NB	PL	6.0	12.0	0.0	8.0	60.0	0	8.0
465+12.07	SB	DL	6.0	6.0	4.0	0.0	36.0	0	4.0
467+81.35	SB	DL	10.0	6.0	0.0	6.7	44.0	0	6.7
469+23.91	SB	DL	6.0	6.0	4.0	0.0	36.0	0	4.0
472+67.11	SB	DL	6.0	12.0	0.0	8.0	60.0	0	8.0
480+48.55	SB	DL	6.0	6.0	4.0	0.0	36.0	0	4.0
483+60.07	SB	DL	6.0	6.0	4.0	0.0	36.0	0	4.0
484+07.59	SB	DL	6.0	12.0	0.0	8.0	60.0	0	8.0
486+13.51	SB	DL	6.0	12.0	0.0	8.0	60.0	0	8.0
486+18.79	SB	DL	6.0	6.0	4.0	0.0	36.0	0	4.0
494+16.07	SB	DL	6.0	12.0	0.0	8.0	60.0	0	8.0
503+03.11	SB	DL	6.0	12.0	0.0	8.0	60.0	0	8.0
TOTALS =					20.0	54.7	584.0	0.0	74.7
USE =					20.0	55.0	584.0	0.0	75.0

CLASS A PATCHES

STATION	DIRECTION	LANE	LENGTH (FOOT)	WIDTH (FOOT)	PATCH AREA		SAW CUTS 44213200 (FOOT)	TIE BARS Z0075300 (EACH)	PATCHING REINFORCEMENT 44213000 (SQ YD)
					TYPE IV, 7.0" 44200523 (SQ YD)	44213200 (FOOT)			
1442+00.00	NB	DL	660.0	6.0	440.0		1344.0	330	440.0
1448+60.00	NB	DL	660.0	6.0	440.0		1344.0	330	440.0
1468+40.00	NB	DL	660.0	6.0	440.0		1344.0	330	440.0
1475+00.00	NB	DL	660.0	6.0	440.0		1344.0	330	440.0
1481+60.00	NB	DL	660.0	6.0	440.0		1344.0	330	440.0
1500+40.00	NB	DL	660.0	6.0	440.0		1344.0	330	440.0
137+90.00	NB	DL	660.0	6.0	440.0		1344.0	330	440.0
144+50.00	NB	DL	660.0	6.0	440.0		1344.0	330	440.0
155+33.87	NB	DL	660.0	6.0	440.0		1344.0	330	440.0
161+93.87	NB	DL	660.0	6.0	440.0		1344.0	330	440.0
TOTALS =					4,400.0		13,440.0	3,300.0	4,400.0
USE =					4,400.0		13,440.0	3,300.0	4,400.0

CLASS A PATCHES

STATION	DIRECTION	LANE	LENGTH (FOOT)	WIDTH (FOOT)	PATCH AREA				SAW CUTS 44213200 (FOOT)	TIE BARS Z0075300 (EACH)	PATCHING REINFORCEMENT 44213000 (SQ YD)
					TYPE I, 10.0" 44200553 (SQ YD)	TYPE II, 10.0" 44200553 (SQ YD)	TYPE III, 10.0" 44200557 (SQ YD)	TYPE IV, 10.0" 44200559 (SQ YD)			
231+69.19	NB	DL	10.0	6.0	0.0	6.7	0.0	0.0	44.0	0	6.7
462+32.23	NB	PL	6.0	12.0	0.0	8.0	0.0	0.0	60.0	0	8.0
525+84.07	NB	DL	6.0	12.0	0.0	8.0	0.0	0.0	60.0	0	8.0
527+63.59	NB	DL	6.0	12.0	0.0	8.0	0.0	0.0	60.0	0	8.0
527+63.59	NB	PL	6.0	12.0	0.0	8.0	0.0	0.0	60.0	0	8.0
546+90.59	NB	PL	6.0	12.0	0.0	8.0	0.0	0.0	60.0	0	8.0
1400+00.00	SB	DL	6.0	12.0	0.0	8.0	0.0	0.0	60.0	0	8.0
1410+00.00	SB	DL	6.0	12.0	0.0	8.0	0.0	0.0	60.0	0	8.0
1420+00.00	SB	DL	6.0	12.0	0.0	8.0	0.0	0.0	60.0	0	8.0
1430+00.00	SB	DL	6.0	12.0	0.0	8.0	0.0	0.0	60.0	0	8.0
1435+00.00	SB	DL	6.0	12.0	0.0	8.0	0.0	0.0	60.0	0	8.0
1440+00.00	SB	DL	6.0	12.0	0.0	8.0	0.0	0.0	60.0	0	8.0
1445+00.00	SB	DL	6.0	12.0	0.0	8.0	0.0	0.0	60.0	0	8.0
1450+00.00	SB	DL	6.0	12.0	0.0	8.0	0.0	0.0	60.0	0	8.0
1455+00.00	SB	DL	6.0	12.0	0.0	8.0	0.0	0.0	60.0	0	8.0
1460+00.00	SB	DL	6.0	12.0	0.0	8.0	0.0	0.0	60.0	0	8.0
319+49.83	SB	DL	6.0	6.0	4.0	0.0	0.0	0.0	36.0	0	4.0
322+98.31	SB	DL	6.0	6.0	4.0	0.0	0.0	0.0	36.0	0	4.0
421+03.27	SB	DL	6.0	6.0	4.0	0.0	0.0	0.0	36.0	0	4.0
459+89.35	SB	DL	20.0	6.0	0.0	13.3	0.0	0.0	64.0	10	13.3
541+68.07	SB	DL	6.0	6.0	4.0	0.0	0.0	0.0	36.0	0	4.0
542+63.11	SB	DL	6.0	12.0	0.0	8.0	0.0	0.0	60.0	0	8.0
546+16.87	SB	DL	6.0	6.0	4.0	0.0	0.0	0.0	36.0	0	4.0
546+43.27	SB	DL	6.0	6.0	4.0	0.0	0.0	0.0	36.0	0	4.0
377+75.98	IL 133	RAMP C	12.0	8.0	0.0	10.7	0.0	0.0	56.0	0	10.7
377+89.98	IL 133	RAMP C	6.0	8.0	0.0	5.3	0.0	0.0	44.0	0	5.3
378+04.98	IL 133	RAMP C	16.0	8.0	0.0	14.2	0.0	0.0	64.0	0	14.2
378+62.98	IL 133	RAMP C	20.0	8.0	0.0	0.0	17.8	0.0	72.0	10	17.8
379+98.98	IL 133	RAMP C	6.0	8.0	0.0	5.3	0.0	0.0	44.0	0	5.3
381+43.98	IL 133	RAMP C	6.0	8.0	0.0	5.3	0.0	0.0	44.0	0	5.3
381+75.98	IL 133	RAMP C	6.0	8.0	0.0	5.3	0.0	0.0	44.0	0	5.3
381+88.98	IL 133	RAMP C	6.0	8.0	0.0	5.3	0.0	0.0	44.0	0	5.3
388+23.98	IL 133	RAMP C	4.0	16.0	0.0	7.1	0.0	0.0	72.0	0	7.1
393+99.98	IL 133	RAMP C	30.0	8.0	0.0	0.0	0.0	26.7	92.0	15	26.7
394+57.98	IL 133	RAMP C	8.0	8.0	0.0	7.1	0.0	0.0	48.0	0	7.1
394+96.98	IL 133	RAMP C	10.0	20.0	0.0	0.0	22.2	0.0	100.0	0	22.2
TOTALS =					24.0	213.8	40.0	26.7	2008.0	35.0	304.4
USE =					24.0	214.0	40.0	27.0	2008.0	35.0	305.0

44400100 FIBERGLASS FABRIC REPAIR SYSTEM

LOCATION	STATION	TO	STATION	WIDTH (FOOT)	AREA (SQ YD)
N.B. DRIVING LANE	1455+20.00	TO	1468+40.00	6.0	880.0
N.B. DRIVING LANE	1488+20.00	TO	1491+86.53	6.0	244.4
N.B. DRIVING LANE	1493+86.53	TO	1500+40.00	6.0	435.6
N.B. DRIVING LANE	129+62.99	TO	137+90.00	6.0	551.3
N.B. DRIVING LANE	152+90.00	TO	155+33.87	6.0	162.6
TOTAL=					2,273.9
USE=					2274.0

ILLINOIS DEPARTMENT OF TRANSPORTATION

SCHEDULE OF QUANTITIES

F.A.I. ROUTE 57
SECTION (15,21-25,21-26,27)RS-1
DOUGLAS COUNTY

SCALE: N/A
DATE: 08-2008

DRAWN BY: RC
CHECKED BY: KD

F.A.I. RTE.	SECTION	COUNTY	TOTAL SHEETS	SHEET NO.
57	*	DOUGLAS	76	26

*(15,21-25,21-26,27)RS-1

SCHEDULE OF QUANTITIES

PARTIAL DEPTH PATCHES

STATION	DIRECTION	LANE	LENGTH (FOOT)	WIDTH (FOOT)	EXISTING OVERLAY THICKNESS (4 3/4" or less) (INCH)	PARTIAL DEPTH REMOVAL X4401705 (SQ YD)	PARTIAL DEPTH PATCHING X4421000 (TONS)
IL 133							
114+58.49	SB EXIT	RAMP A	6.0	8.0	2.5	5.3	1.6
115+89.49	SB EXIT	RAMP A	6.0	16.0	2.5	10.7	3.3
116+72.49	SB EXIT	RAMP A	4.0	16.0	2.5	7.1	2.2
117+38.49	SB EXIT	RAMP A	4.0	8.0	2.5	3.6	1.1
117+72.49	SB EXIT	RAMP A	4.0	16.0	2.5	7.1	2.2
119+70.49	SB EXIT	RAMP A	5.0	16.0	2.5	8.9	2.7
121+70.49	SB EXIT	RAMP A	4.0	16.0	2.5	7.1	2.2
123+67.49	SB EXIT	RAMP A	4.0	16.0	2.5	7.1	2.2
124+68.49	SB EXIT	RAMP A	4.0	16.0	2.5	7.1	2.2
128+70.49	SB EXIT	RAMP A	4.0	16.0	2.5	7.1	2.2
IL 133							
231+37.09	NB ENTRANCE	RAMP B	4.0	16.0	2.5	7.1	2.2
238+39.09	NB ENTRANCE	RAMP B	8.0	16.0	2.5	14.2	4.4
239+32.09	NB ENTRANCE	RAMP B	4.0	16.0	2.5	7.1	2.2
239+43.09	NB ENTRANCE	RAMP B	4.0	16.0	2.5	7.1	2.2
240+37.09	NB ENTRANCE	RAMP B	5.0	16.0	2.5	8.9	2.7
241+35.09	NB ENTRANCE	RAMP B	4.0	16.0	2.5	7.1	2.2
241+96.09	NB ENTRANCE	RAMP B	16.0	16.0	2.5	28.4	8.8
243+62.09	NB ENTRANCE	RAMP B	6.0	16.0	2.5	10.7	3.3
244+61.09	NB ENTRANCE	RAMP B	6.0	8.0	2.5	5.3	1.6
US 36							
0+63.00	SB ENTRANCE	RAMP A	16.0	20.0	3.5	35.6	12.9
1+40.00	SB ENTRANCE	RAMP A	5.0	16.0	3.5	8.9	3.2
2+28.00	SB ENTRANCE	RAMP A	8.0	16.0	3.5	14.2	5.2
5+30.00	SB ENTRANCE	RAMP A	5.0	16.0	3.5	8.9	3.2
6+30.00	SB ENTRANCE	RAMP A	6.0	16.0	3.5	10.7	3.9
11+41.00	SB ENTRANCE	RAMP A	4.0	16.0	3.5	7.1	2.6
17+76.00	SB ENTRANCE	RAMP A	8.0	8.0	3.5	7.1	2.6
18+23.00	SB ENTRANCE	RAMP A	4.0	16.0	3.5	7.1	2.6
19+21.00	SB ENTRANCE	RAMP A	4.0	16.0	3.5	7.1	2.6
19+52.00	SB ENTRANCE	RAMP A	16.0	8.0	3.5	14.2	5.2
20+20.00	SB ENTRANCE	RAMP A	4.0	16.0	3.5	7.1	2.6
20+40.00	SB ENTRANCE	RAMP A	4.0	16.0	3.5	7.1	2.6
20+50.00	SB ENTRANCE	RAMP A	50.0	8.0	3.5	44.4	16.2
US 36							
100+63.13	SB EXIT	RAMP B	5.0	16.0	3.5	8.9	3.2
101+77.13	SB EXIT	RAMP B	4.0	16.0	3.5	7.1	2.6
106+26.13	SB EXIT	RAMP B	6.0	16.0	3.5	10.7	3.9
110+23.13	SB EXIT	RAMP B	6.0	16.0	3.5	10.7	3.9
111+70.13	SB EXIT	RAMP B	10.0	16.0	3.5	17.8	6.5
112+71.13	SB EXIT	RAMP B	4.0	16.0	3.5	7.1	2.6
114+72.13	SB EXIT	RAMP B	4.0	16.0	3.5	7.1	2.6
115+73.13	SB EXIT	RAMP B	4.0	16.0	3.5	7.1	2.6
116+72.13	SB EXIT	RAMP B	4.0	16.0	3.5	7.1	2.6
117+37.13	SB EXIT	RAMP B	20.0	16.0	3.5	35.6	12.9
117+57.13	SB EXIT	RAMP B	6.0	16.0	3.5	10.7	3.9
TOTALS =						476.4	164.1

PARTIAL DEPTH PATCHES

STATION	DIRECTION	LANE	LENGTH (FOOT)	WIDTH (FOOT)	EXISTING OVERLAY THICKNESS (4 3/4" or less) (INCH)	PARTIAL DEPTH REMOVAL X4401705 (SQ YD)	PARTIAL DEPTH PATCHING X4421000 (TONS)
US 36							
200+55.60	NB EXIT	RAMP C	6.0	16.0	3.5	10.7	3.9
201+51.60	NB EXIT	RAMP C	4.0	16.0	3.5	7.1	2.6
204+29.60	NB EXIT	RAMP C	4.0	16.0	3.5	7.1	2.6
206+04.60	NB EXIT	RAMP C	5.0	16.0	3.5	8.9	3.2
206+89.60	NB EXIT	RAMP C	6.0	16.0	3.5	10.7	3.9
209+23.60	NB EXIT	RAMP C	35.0	8.0	3.5	31.1	11.3
214+19.60	NB EXIT	RAMP C	4.0	16.0	3.5	7.1	2.6
216+96.60	NB EXIT	RAMP C	4.0	18.0	3.5	8.0	2.9
217+29.60	NB EXIT	RAMP C	4.0	16.0	3.5	7.1	2.6
217+29.60	NB EXIT	RAMP C	4.0	16.0	3.5	7.1	2.6
217+51.60	NB EXIT	RAMP C	4.0	16.0	3.5	7.1	2.6
217+51.60	NB EXIT	RAMP C	6.0	16.0	3.5	10.7	3.9
US 36							
300+62.00	NB ENTRANCE	RAMP D	4.0	16.0	3.5	7.1	2.6
308+08.00	NB ENTRANCE	RAMP D	4.0	8.0	3.5	3.6	1.3
315+88.00	NB ENTRANCE	RAMP D	4.0	16.0	3.5	7.1	2.6
TOTALS =						140.4	51.1
GRAND TOTALS =						616.9	215.2
USE =						617.0	216.0

SEEDING & EROSION CONTROL

LOCATION	AREA (ACRE)	28000250 TEMPORARY EROSION SEEDING (POUND)	25000350 SEEDING CLASS 7 (ACRE)	25000210 SEEDING CLASS 2A (ACRE)	25000400 NITROGEN FERTILIZER NUTRIENT (POUND)	25000500 PHOSPHORUS FERTILIZER NUTRIENT (POUND)	25000600 POTASSIUM FERTILIZER NUTRIENT (POUND)	25100115 MULCH METHOD 2 (ACRE)	28000300 TEMPORARY DITCH CHECKS (EACH)	28000500 INLET & PIPE PROTECTION (EACH)	
PROPOSED TYPICAL 1											
NORTHBOUND RT	1.98	198.0	1.98	1.98	178.2	178.2	178.2	1.98	0.0	0.0	
SOUTHBOUND RT	1.98	198.0	1.98	1.98	178.2	178.2	178.2	1.98	0.0	0.0	
NORTHBOUND LT	2.40	240.0	2.40	2.40	216.0	216.0	216.0	2.40	0.0	0.0	
SOUTHBOUND LT	2.40	240.0	2.40	2.40	216.0	216.0	216.0	2.40	0.0	0.0	
PROPOSED TYPICAL 2A											
NORTHBOUND RT	1.43	143.0	1.43	1.43	128.7	128.7	128.7	1.43	0.0	0.0	
SOUTHBOUND RT	2.15	215.0	2.15	2.15	193.5	193.5	193.5	2.15	0.0	0.0	
NORTHBOUND LT	1.43	143.0	1.43	1.43	128.7	128.7	128.7	1.43	0.0	0.0	
SOUTHBOUND LT	2.06	206.0	2.06	2.06	185.4	185.4	185.4	2.06	0.0	0.0	
PROPOSED TYPICAL 2B											
NORTHBOUND RT	1.14	114.0	1.14	1.14	102.6	102.6	102.6	1.14	0.0	0.0	
NORTHBOUND LT	1.25	125.0	1.25	1.25	112.5	112.5	112.5	1.25	0.0	0.0	
PROPOSED TYPICAL 3											
NORTHBOUND RT	0.44	44.0	0.44	0.44	39.6	39.6	39.6	0.44	0.0	0.0	
SOUTHBOUND RT	0.34	34.0	0.34	0.34	30.6	30.6	30.6	0.34	0.0	0.0	
NORTHBOUND LT	0.44	44.0	0.44	0.44	39.6	39.6	39.6	0.44	0.0	0.0	
SOUTHBOUND LT	0.44	44.0	0.44	0.44	39.6	39.6	39.6	0.44	0.0	0.0	
MEDIAN X-OVERS											
STA. 1431+00.00	0.03	3.0	0.03	0.03	2.7	2.7	2.7	0.03	1.0	1.0	
STA. 142+80.00	0.03	3.0	0.03	0.03	2.7	2.7	2.7	0.03	1.0	1.0	
STA. 293+93.00	0.03	3.0	0.03	0.03	2.7	2.7	2.7	0.03	1.0	0.0	
STA. 478+54.00	0.03	3.0	0.03	0.03	2.7	2.7	2.7	0.03	0.0	1.0	
TOTAL =		20.0	2,000.0	20.0	20.0	1,800.0	1,800.0	1,800.0	20.0	3.0	3.0
USE =		20.0	2,000.0	20.0	20.0	1,800.0	1,800.0	1,800.0	20.0	3.0	3.0

ILLINOIS DEPARTMENT OF TRANSPORTATION
SCHEDULE OF QUANTITIES
 F.A.I. ROUTE 57
 SECTION (15,21-25,21-26,27)RS-1
 DOUGLAS COUNTY

SCALE: N/A
 DATE: 08-2008

DRAWN BY: RC
 CHECKED BY: KD

F.A.I. RTE.	SECTION	COUNTY	TOTAL SHEETS	SHEET NO.
57	*	DOUGLAS	76	27

STA. 1366+00		TO STA. 1395+00	
FED. ROAD DIST. NO.	ILLINOIS	FED. AID PROJECT	
			* (15,21-25,21-26,27)RS-1

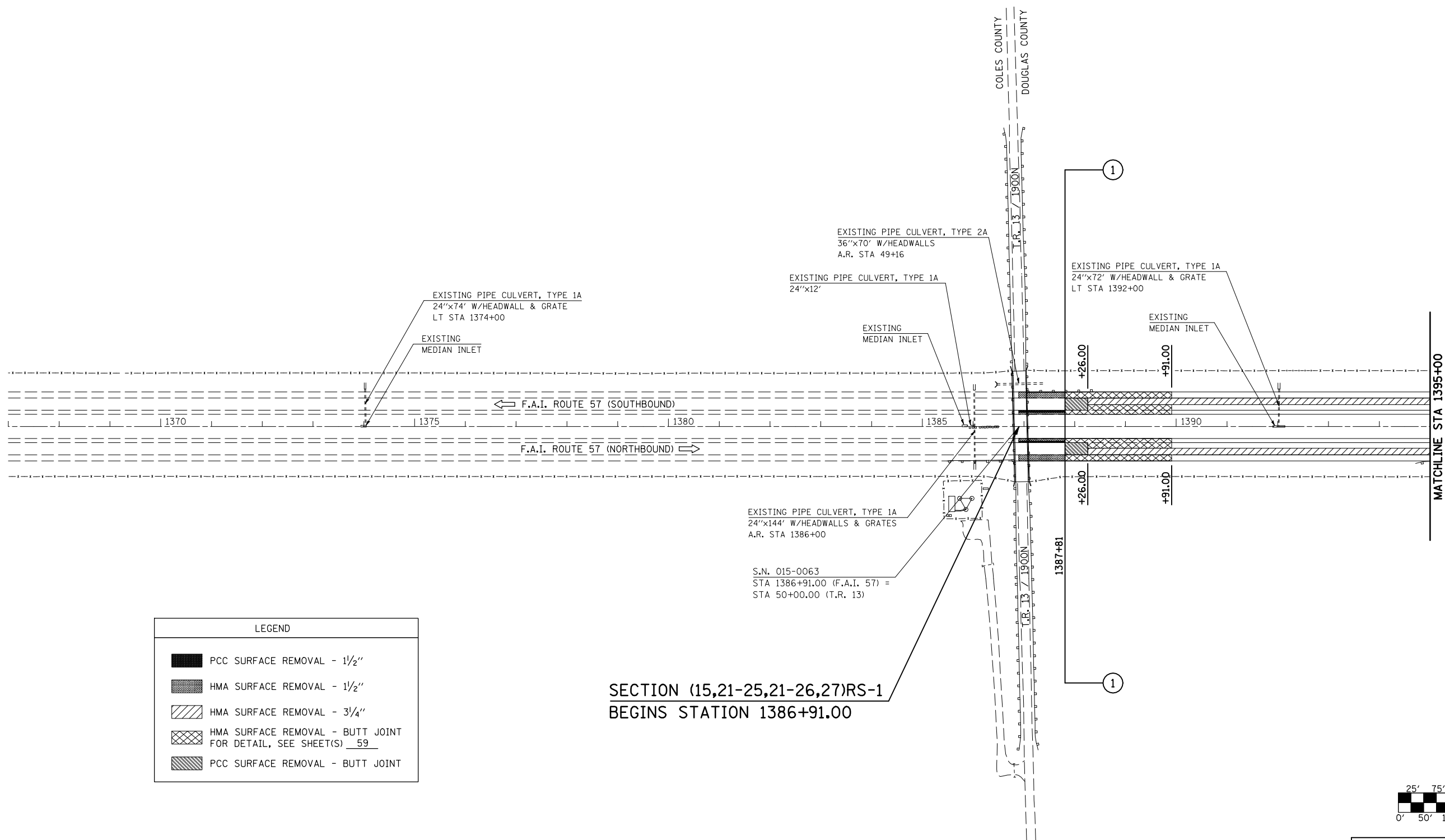

LEGEND	
	PCC SURFACE REMOVAL - 1 1/2"
	HMA SURFACE REMOVAL - 1 1/2"
	HMA SURFACE REMOVAL - 3/4"
	HMA SURFACE REMOVAL - BUTT JOINT FOR DETAIL, SEE SHEET(S) 59
	PCC SURFACE REMOVAL - BUTT JOINT

SECTION (15,21-25,21-26,27)RS-1
 BEGINS STATION 1386+91.00

SEC. 22, T. 14 N., R. 8 E., 3RD P.M.

SEC. 15, T. 14 N., R. 8 E., 3RD P.M.

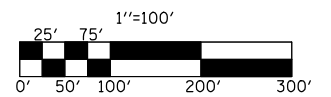

ILLINOIS DEPARTMENT OF TRANSPORTATION
PLAN VIEW
 F.A.I. ROUTE 57
 SECTION (15,21-25,21-26,27)RS-1
 DOUGLAS COUNTY

SCALE: 1" = 100'
 DATE: 01/19/06

DRAWN BY: J.P.
 CHECKED BY: K.D.

PLOT DATE = 8/21/2008
 FILE NAME = c:\p\projects\152125\152125.dwg
 PLOT SCALE = 211.7647 / IN.
 USER NAME = sheehyjm

F.A.I. RTE.	SECTION	COUNTY	TOTAL SHEETS	SHEET NO.
57	*	DOUGLAS	76	28
STA. 1395+00		TO STA. 1424+00		
FED. ROAD DIST. NO.		ILLINOIS	FED. AID PROJECT	
* (15,21-25,21-26,27)RS-1				

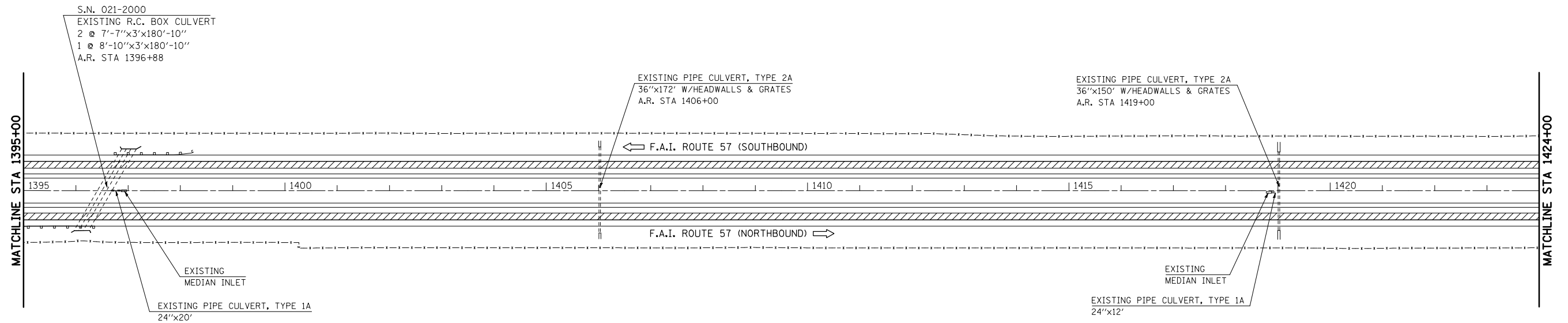

LEGEND	
	HMA SURFACE REMOVAL - 3/4"

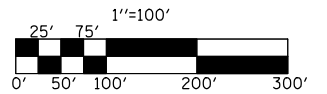

SEC. 15, T. 14 N., R. 8 E., 3RD P.M.

ILLINOIS DEPARTMENT OF TRANSPORTATION
PLAN VIEW
F.A.I. ROUTE 57
SECTION (15,21-25,21-26,27)RS-1
DOUGLAS COUNTY

SCALE: 1" = 100'
DATE: 01/19/06

DRAWN BY: J.P.
CHECKED BY: K.D.

F.A.I. RTE.	SECTION	COUNTY	TOTAL SHEETS	SHEET NO.
57	*	DOUGLAS	76	29
STA. 1424+00		TO STA. 1453+00		
FED. ROAD DIST. NO.		ILLINOIS	FED. AID PROJECT	
*(15,21-25,21-26,27)RS-1				

EXIST. CURVE DATA
 PI STA. = 1432+81.33
 Δ = 5° 25' 47" (RT)
 D = 0° 20' 00"
 R = 17,188.71'
 T = 815.07'
 L = 1,628.92'
 E = 19.31'
 e = -----
 T.R. = -----
 S.E. RUN = -----
 P.C. STA. = 1424+66.26
 P.T. STA. = 1440+95.18

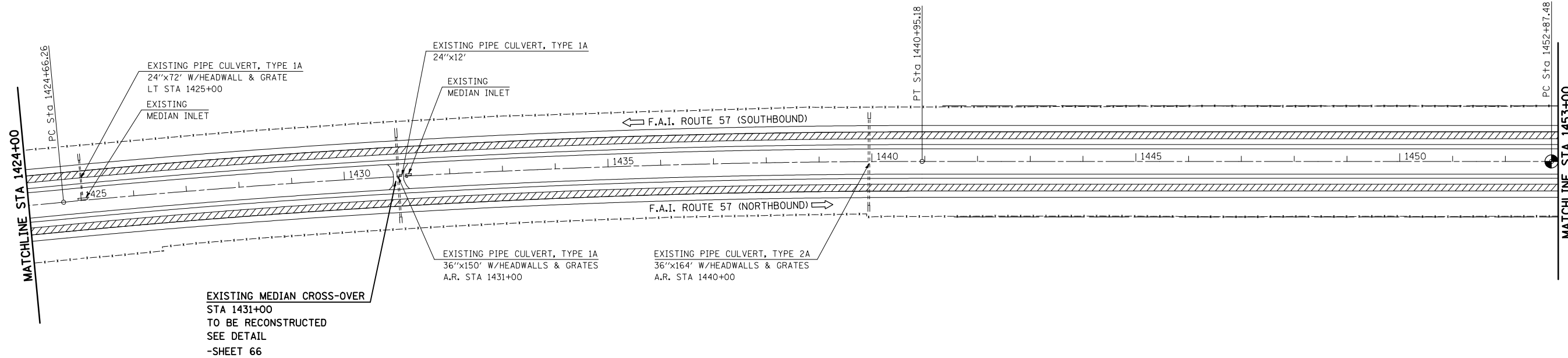

LEGEND	
	HMA SURFACE REMOVAL - 3/4"

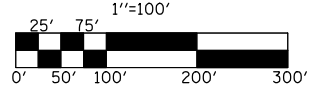

ILLINOIS DEPARTMENT OF TRANSPORTATION
PLAN VIEW
 F.A.I. ROUTE 57
 SECTION (15,21-25,21-26,27)RS-1
 DOUGLAS COUNTY

SCALE: 1" = 100'
 DATE: 01/19/06

DRAWN BY: J.P.
 CHECKED BY: K.D.

SEC. 15, T. 14 N., R. 8 E., 3RD P.M.

PLOT DATE = 8/21/2008
 FILE NAME = c:\p\projects\0501305 (v8)\100planshts.dgn
 PLOT SCALE = 211.7647' / IN.
 USER NAME = sheehyjm

F.A.I. RTE.	SECTION	COUNTY	TOTAL SHEETS	SHEET NO.
57	*	DOUGLAS	76	30
STA. 1453+00		TO STA. 1480+00		
FED. ROAD DIST. NO.		ILLINOIS	FED. AID PROJECT	
* (15,21-25,21-26,27)RS-1				

EXIST. CURVE DATA
 PI STA. = 1460+21.14
 $\Delta = 4^\circ 53' 17''$ (LT)
 $D = 0^\circ 20' 00''$
 $R = 17,188.76'$
 $T = 733.66'$
 $L = 1,466.42'$
 $E = 15.65'$
 $e = \text{-----}$
 $T.R. = \text{-----}$
 $S.E. RUN = \text{-----}$
 $P.C. STA. = 1452+87.48$
 $P.T. STA. = 1467+53.90$

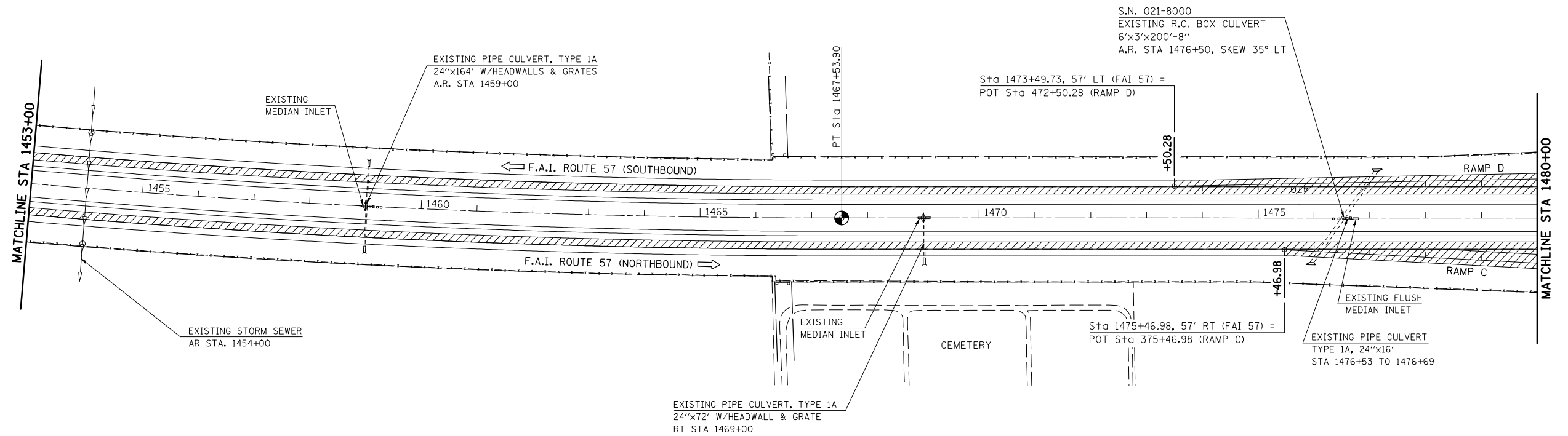

LEGEND	
	HMA SURFACE REMOVAL - 3/4"

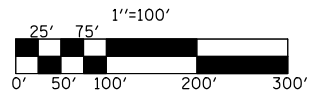

SEC. 10, T. 14 N., R. 8 E., 3RD P.M.

ILLINOIS DEPARTMENT OF TRANSPORTATION
PLAN VIEW
 F.A.I. ROUTE 57
 SECTION (15,21-25,21-26,27)RS-1
 DOUGLAS COUNTY
 SCALE: 1" = 100'
 DATE: 01/19/06
 DRAWN BY: J.P.
 CHECKED BY: K.D.

F.A.I. RTE.	SECTION	COUNTY	TOTAL SHEETS	SHEET NO.
57	*	DOUGLAS	76	31

STA. 1480+00 TO STA. 1509+00
 FED. ROAD DIST. NO. ILLINOIS FED. AID PROJECT
 *(15,21-25,21-26,27)RS-1

EXIST. CURVE 133RMPD-1
 PI STA. = 454+00.44
 $\Delta = 64^\circ 43' 00''$ (LT)
 D = 23° 17' 27"
 R = 246.00'
 T = 155.87'
 L = 277.86'
 E = 45.22'
 e = -----
 T.R. = -----
 S.E. RUN = -----
 P.C. STA. = 452+44.57
 P.T. STA. = 455+22.43

EXIST. CURVE 133RMPD-2
 PI STA. = 459+29.63
 $\Delta = 48^\circ 42' 59''$ (RT)
 D = 13° 19' 29"
 R = 430.00'
 T = 194.68'
 L = 365.61'
 E = 42.02'
 e = -----
 T.R. = -----
 S.E. RUN = -----
 P.C. STA. = 457+34.95
 P.T. STA. = 461+00.56

EXIST. CURVE 133RMPD-3
 PI STA. = 462+01.15
 $\Delta = 16^\circ 35' 15''$ (RT)
 D = 8° 18' 13"
 R = 690.00'
 T = 100.58'
 L = 199.76'
 E = 7.29'
 e = -----
 T.R. = -----
 S.E. RUN = -----
 P.C. STA. = 461+00.56
 P.T. STA. = 463+00.32

EXIST. CURVE 133RMPA-1
 PI STA. = 120+01.39
 $\Delta = 53^\circ 08' 33''$ (RT)
 D = 8° 18' 13"
 R = 690.00'
 T = 345.09'
 L = 639.98'
 E = 81.49'
 e = -----
 T.R. = -----
 S.E. RUN = -----
 P.C. STA. = 116+56.30
 P.T. STA. = 122+96.28

EXIST. CURVE 133RMPA-2
 PI STA. = 126+67.45
 $\Delta = 57^\circ 53' 58''$ (LT)
 D = 23° 17' 27"
 R = 246.00'
 T = 136.08'
 L = 248.59'
 E = 35.13'
 e = -----
 T.R. = -----
 S.E. RUN = -----
 P.C. STA. = 125+31.37
 P.T. STA. = 127+79.96

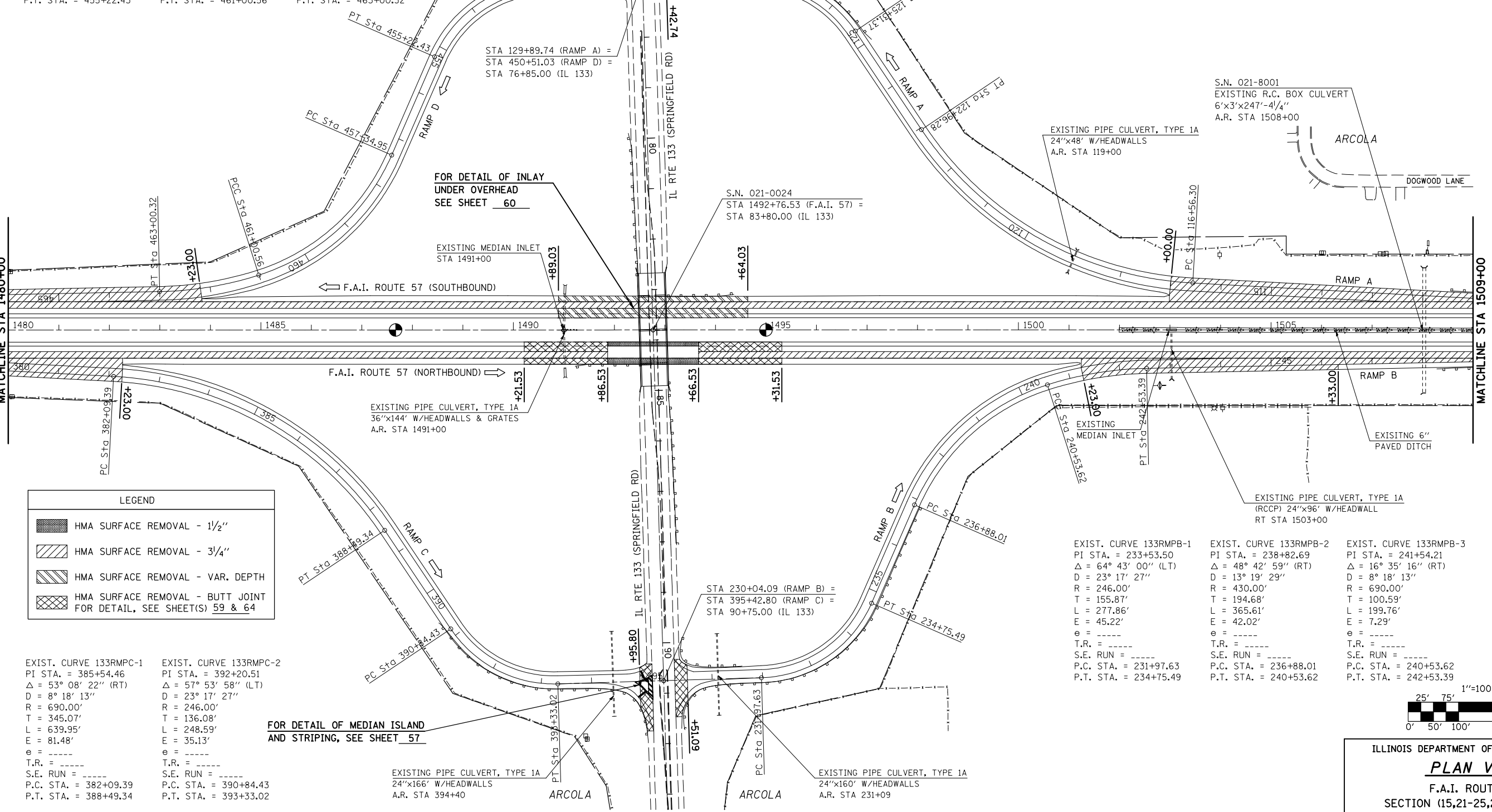

LEGEND

	HMA SURFACE REMOVAL - 1/2"
	HMA SURFACE REMOVAL - 3/4"
	HMA SURFACE REMOVAL - VAR. DEPTH
	HMA SURFACE REMOVAL - BUTT JOINT FOR DETAIL, SEE SHEET(S) 59 & 64

EXIST. CURVE 133RMPB-1
 PI STA. = 385+54.46
 $\Delta = 53^\circ 08' 22''$ (RT)
 D = 8° 18' 13"
 R = 690.00'
 T = 345.07'
 L = 639.95'
 E = 81.48'
 e = -----
 T.R. = -----
 S.E. RUN = -----
 P.C. STA. = 382+09.39
 P.T. STA. = 388+49.34

EXIST. CURVE 133RMPB-2
 PI STA. = 392+20.51
 $\Delta = 57^\circ 53' 58''$ (LT)
 D = 23° 17' 27"
 R = 246.00'
 T = 136.08'
 L = 248.59'
 E = 35.13'
 e = -----
 T.R. = -----
 S.E. RUN = -----
 P.C. STA. = 390+84.43
 P.T. STA. = 393+33.02

EXIST. CURVE 133RMPB-1
 PI STA. = 233+53.50
 $\Delta = 64^\circ 43' 00''$ (LT)
 D = 23° 17' 27"
 R = 246.00'
 T = 155.87'
 L = 277.86'
 E = 45.22'
 e = -----
 T.R. = -----
 S.E. RUN = -----
 P.C. STA. = 231+97.63
 P.T. STA. = 234+75.49

EXIST. CURVE 133RMPB-2
 PI STA. = 238+82.69
 $\Delta = 48^\circ 42' 59''$ (RT)
 D = 13° 19' 29"
 R = 430.00'
 T = 194.68'
 L = 365.61'
 E = 42.02'
 e = -----
 T.R. = -----
 S.E. RUN = -----
 P.C. STA. = 236+88.01
 P.T. STA. = 240+53.62

EXIST. CURVE 133RMPB-3
 PI STA. = 241+54.21
 $\Delta = 16^\circ 35' 16''$ (RT)
 D = 8° 18' 13"
 R = 690.00'
 T = 100.59'
 L = 199.76'
 E = 7.29'
 e = -----
 T.R. = -----
 S.E. RUN = -----
 P.C. STA. = 240+53.62
 P.T. STA. = 242+53.39

PLOT DATE = 8/21/2008
 FILE NAME = c:\p\projects\0801305 (v8)\100planshots.dgn
 PLOT SCALE = 211.7647 / IN.
 USER NAME = sheehyjm

SEC. 10, T. 14 N., R. 8 E., 3RD P.M.

SEC. 3, T. 14 N., R. 8 E., 3RD P.M.

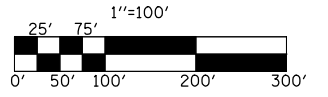

ILLINOIS DEPARTMENT OF TRANSPORTATION
PLAN VIEW
 F.A.I. ROUTE 57
 SECTION (15,21-25,21-26,27)RS-1
 DOUGLAS COUNTY

SCALE: 1" = 100'
 DATE: 01/19/06

DRAWN BY: J.P.
 CHECKED BY: K.D.

F.A.I. RTE.	SECTION	COUNTY	TOTAL SHEETS	SHEET NO.
57	*	DOUGLAS	76	32
STA. 1509+00		TO STA. 142+00		
FED. ROAD DIST. NO.		ILLINOIS	FED. AID PROJECT	
*(15,21-25,21-26,27)RS-1				

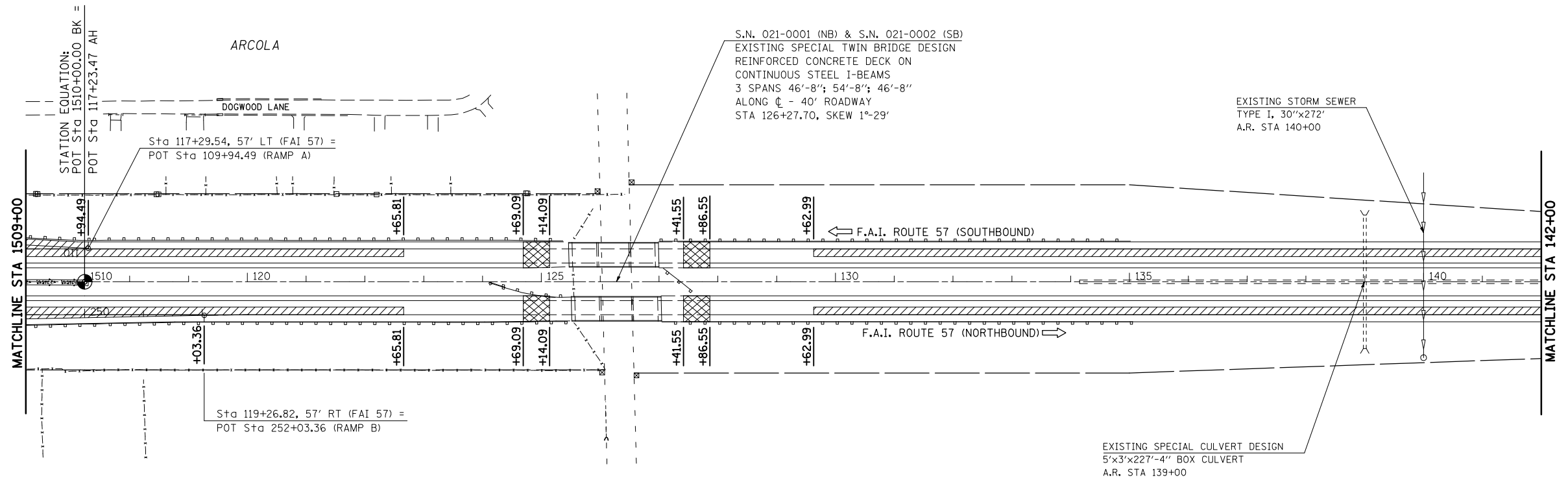

LEGEND	
	HMA SURFACE REMOVAL - 3/4"
	HMA SURFACE REMOVAL - BUTT JOINT FOR DETAIL, SEE SHEET(S) 60

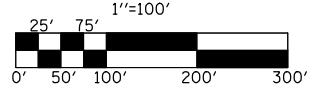

ILLINOIS DEPARTMENT OF TRANSPORTATION
PLAN VIEW
 F.A.I. ROUTE 57
 SECTION (15,21-25,21-26,27)RS-1
 DOUGLAS COUNTY
 SCALE: 1" = 100'
 DATE: 01/19/06
 DRAWN BY: J.P.
 CHECKED BY: K.D.

SEC. 3, T. 14 N., R. 8 E., 3RD P.M.

PLOT DATE = 8/21/2008
 FILE NAME = c:\projects\1501305 (v8)\100plans\1501305.dgn
 PLOT SCALE = 211.7647 / IN.
 USER NAME = sheehyjm

F.A.I. RTE.	SECTION	COUNTY	TOTAL SHEETS	SHEET NO.
57	*	DOUGLAS	76	34
STA. 171+00		TO STA. 201+00		
FED. ROAD DIST. NO.		ILLINOIS	FED. AID PROJECT	
* (15,21-25,21-26,27)RS-1				

EXIST. CURVE DATA
 PI STA. = 190+50.80
 $\Delta = 6^\circ 31' 00''$ (RT)
 $D = 0^\circ 30' 00''$
 $R = 11,459.13'$
 $T = 652.37'$
 $L = 1,303.33'$
 $E = 18.55'$
 $e = \text{-----}$
 $T.R. = \text{-----}$
 $S.E. RUN = \text{-----}$
 $P.C. STA. = 183+98.43$
 $P.T. STA. = 197+01.76$

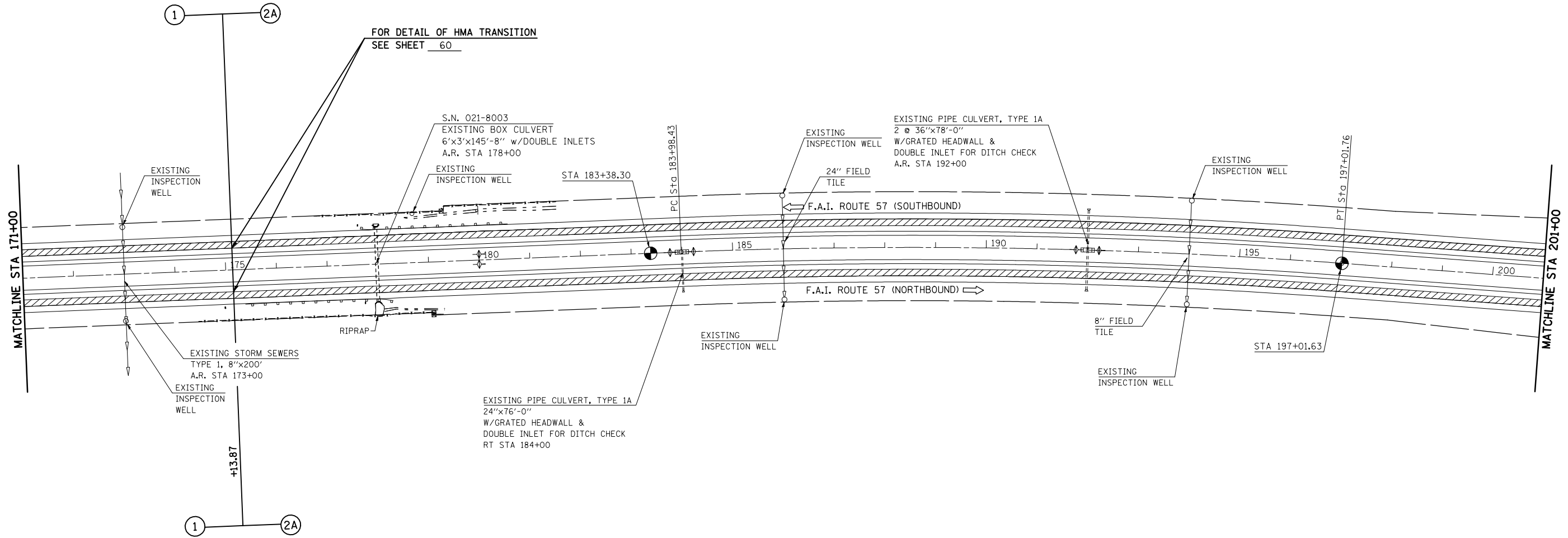

LEGEND	
	HMA SURFACE REMOVAL - 3/4"

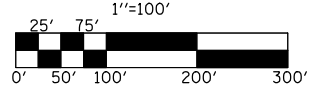

SEC. 34, T. 15 N., R. 8 E., 3RD P.M.

ILLINOIS DEPARTMENT OF TRANSPORTATION
PLAN VIEW
 F.A.I. ROUTE 57
 SECTION (15,21-25,21-26,27)RS-1
 DOUGLAS COUNTY

SCALE: 1" = 100'
 DATE: 01/19/06

DRAWN BY: J.P.
 CHECKED BY: K.D.

PLOT DATE = 8/21/2008
 FILE NAME = c:\p\projects\0801305 (v8)\100plan\shs.dgn
 PLOT SCALE = 211.7647 / IN.
 USER NAME = sheehyjm

F.A.I. RTE.	SECTION	COUNTY	TOTAL SHEETS	SHEET NO.
57	*	DOUGLAS	76	35
STA. 201+00		TO STA. 231+00		
FED. ROAD DIST. NO.		ILLINOIS	FED. AID PROJECT	
* (15,21-25,21-26,27)RS-1				

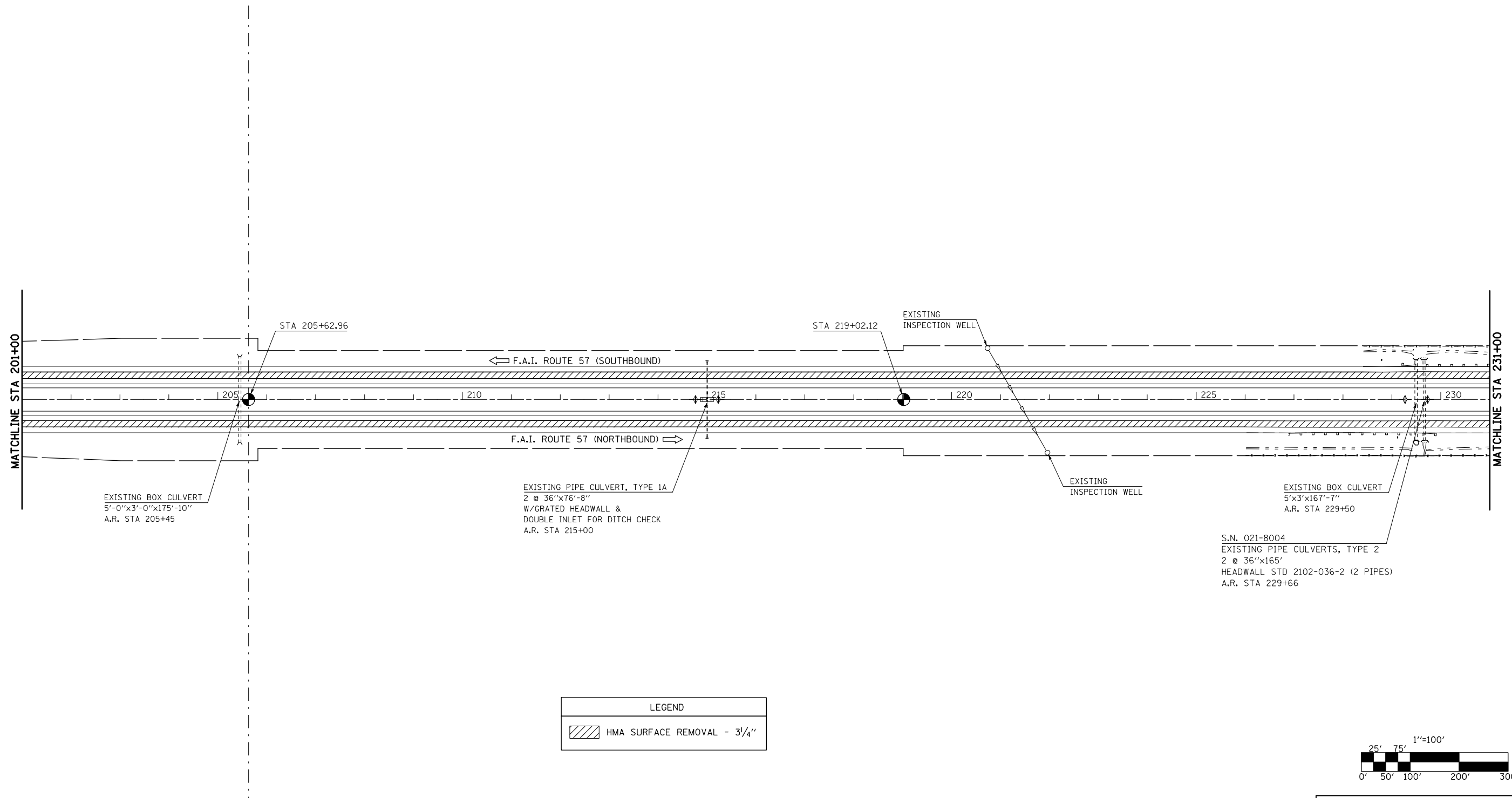

LEGEND	
	HMA SURFACE REMOVAL - 3 1/4"

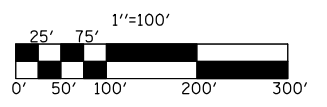

SEC. 34, T. 15 N., R. 8 E., 3RD P.M.

SEC. 27, T. 15 N., R. 8 E., 3RD P.M.

ILLINOIS DEPARTMENT OF TRANSPORTATION
PLAN VIEW
 F.A.I. ROUTE 57
 SECTION (15,21-25,21-26,27)RS-1
 DOUGLAS COUNTY

SCALE: 1" = 100'
 DATE: 01/19/06

DRAWN BY: J.P.
 CHECKED BY: K.D.

PLOT DATE = 8/21/2008
 FILE NAME = c:\projects\1501305 (v8)\100plans\1501305.dgn
 PLOT SCALE = 211.7647' / IN.
 USER NAME = sheehyjm

F.A.I. RTE.	SECTION	COUNTY	TOTAL SHEETS	SHEET NO.
57	*	DOUGLAS	76	36
STA. 231+00		TO STA. 261+00		
FED. ROAD DIST. NO.		ILLINOIS	FED. AID PROJECT	
*(15,21-25,21-26,27)RS-1				

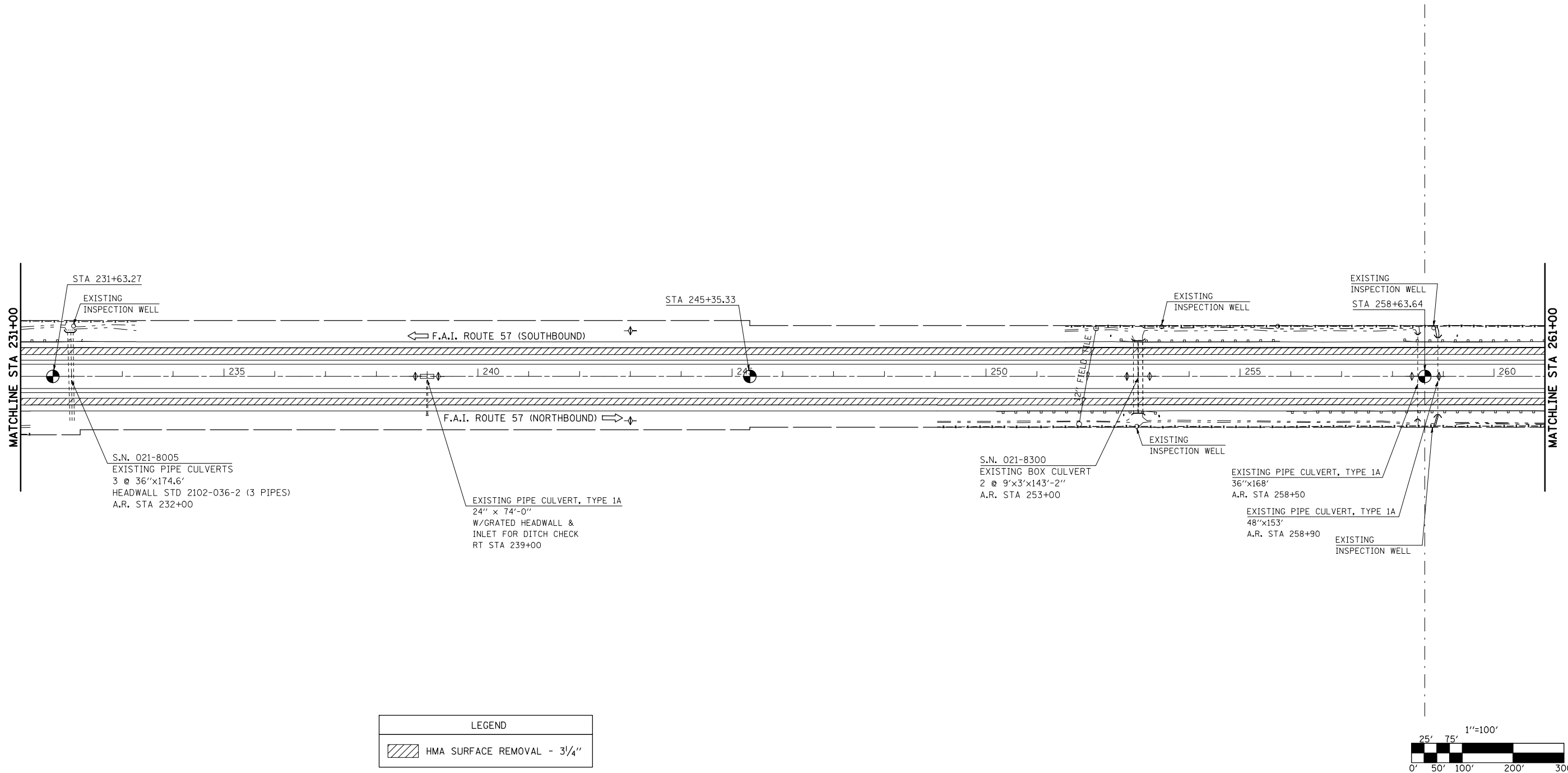
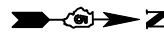

PLOT DATE = 8/21/2008
 FILE NAME = c:\projects\1501305 (v8)\100planshfts.dgn
 PLOT SCALE = 211.7647' / IN.
 USER NAME = sheehyjm

SEC. 27, T. 15 N., R. 8 E., 3RD P.M.

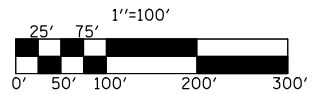

ILLINOIS DEPARTMENT OF TRANSPORTATION

PLAN VIEW

F.A.I. ROUTE 57
 SECTION (15,21-25,21-26,27)RS-1
 DOUGLAS COUNTY

SCALE: 1" = 100'
 DATE: 01/19/06

DRAWN BY: J.P.
 CHECKED BY: K.D.

F.A.I. RTE.	SECTION	COUNTY	TOTAL SHEETS	SHEET NO.
57	*	DOUGLAS	76	37
STA. 261+00		TO STA. 291+00		
FED. ROAD DIST. NO.		ILLINOIS	FED. AID PROJECT	
* (15,21-25,21-26,27)RS-1				

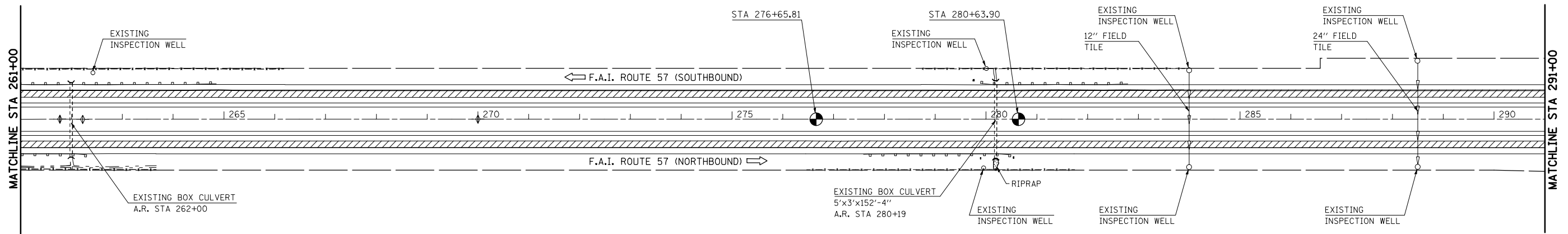

LEGEND	
	HMA SURFACE REMOVAL - 3/4"

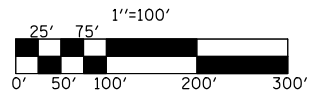

SEC. 22, T. 15 N., R. 8 E., 3RD P.M.

ILLINOIS DEPARTMENT OF TRANSPORTATION
PLAN VIEW
 F.A.I. ROUTE 57
 SECTION (15,21-25,21-26,27)RS-1
 DOUGLAS COUNTY

SCALE: 1" = 100'
 DATE: 01/19/06

DRAWN BY: J.P.
 CHECKED BY: K.D.

F.A.I. RTE.	SECTION	COUNTY	TOTAL SHEETS	SHEET NO.
57	*	DOUGLAS	76	38
STA. 291+00		TO STA. 321+00		
FED. ROAD DIST. NO.		ILLINOIS	FED. AID PROJECT	
* (15,21-25,21-26,27)RS-1				

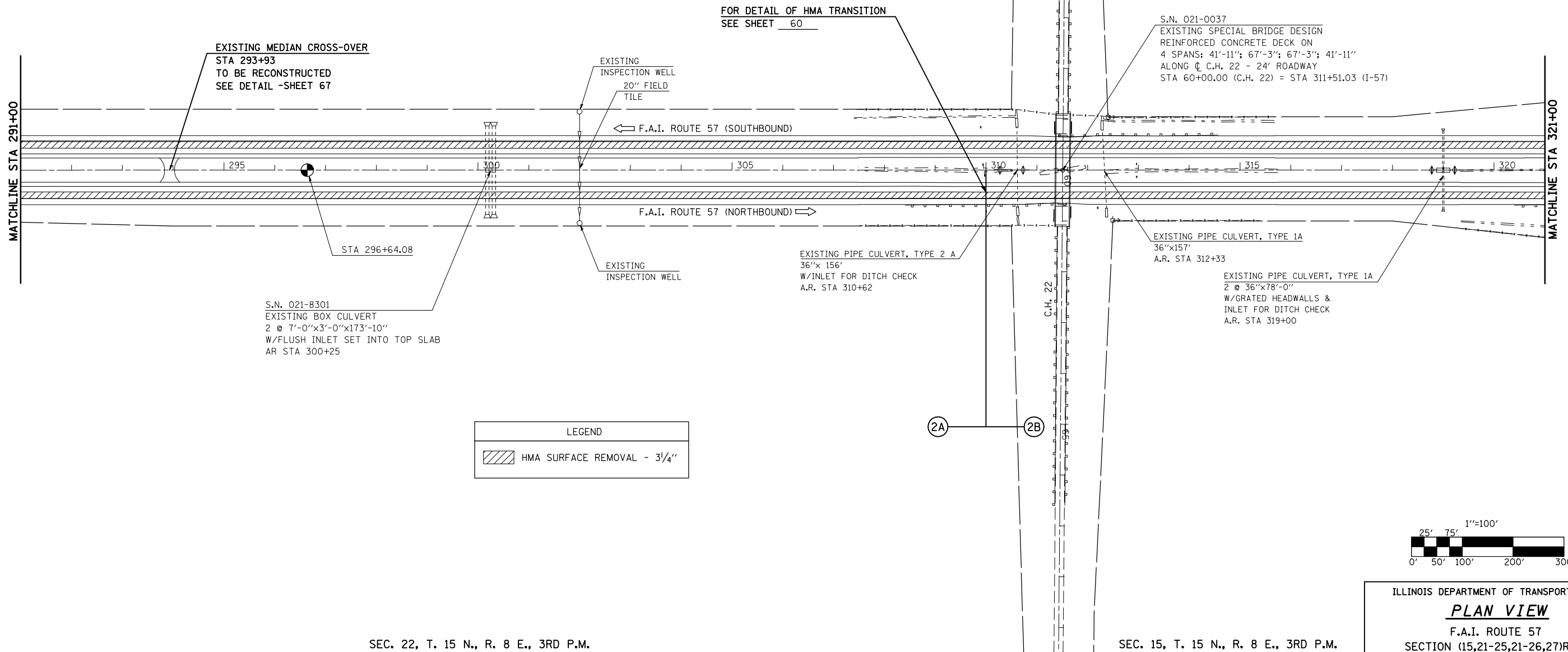

SEC. 22, T. 15 N., R. 8 E., 3RD P.M.

SEC. 15, T. 15 N., R. 8 E., 3RD P.M.

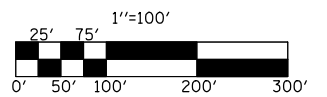

ILLINOIS DEPARTMENT OF TRANSPORTATION
PLAN VIEW
F.A.I. ROUTE 57
SECTION (15,21-25,21-26,27)RS-1
DOUGLAS COUNTY

SCALE: 1" = 100'
DATE: 01/19/06

DRAWN BY: J.P.
CHECKED BY: K.D.

F.A.I. RTE.	SECTION	COUNTY	TOTAL SHEETS	SHEET NO.
57	*	DOUGLAS	76	39
STA. 321+00		TO STA. 350+00		
FED. ROAD DIST. NO.		ILLINOIS	FED. AID PROJECT	
* (15,21-25,21-26,27)RS-1				

EXIST. CURVE DATA
 PI STA. = 341+86.05
 $\Delta = 39^\circ 36' 15''$ (RT)
 $D = 1^\circ 00' 00''$
 $R = 5,729.58'$
 $T = 2,063.01'$
 $L = 3,960.42'$
 $E = 360.09'$
 $e = \text{-----}$
 $T.R. = \text{-----}$
 $S.E. \text{ RUN} = \text{-----}$
 P.C. STA. = 321+23.04
 P.T. STA. = 360+83.46

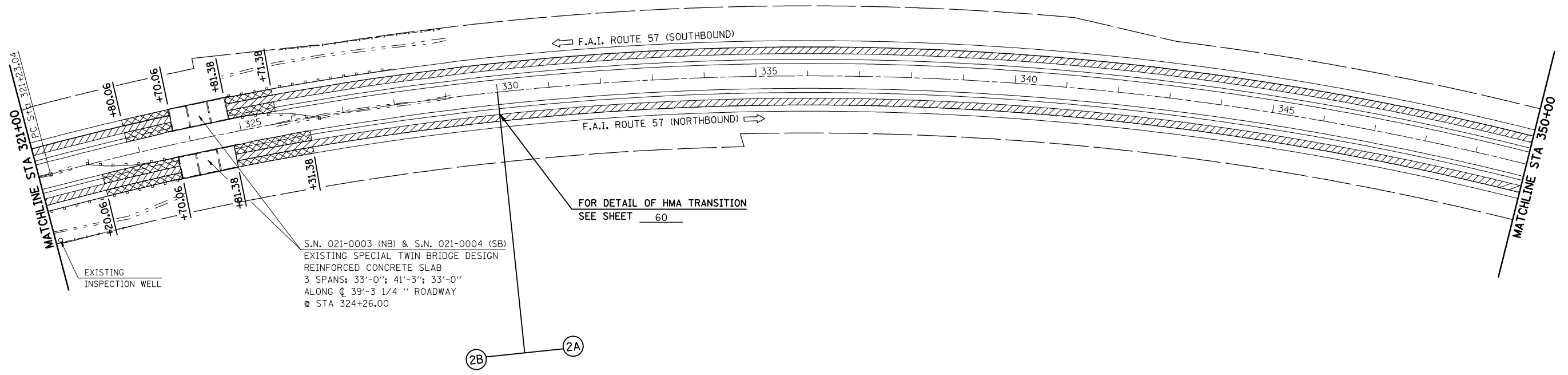

S.N. 021-0003 (NB) & S.N. 021-0004 (SB)
 EXISTING SPECIAL TWIN BRIDGE DESIGN
 REINFORCED CONCRETE SLAB
 3 SPANS: 33'-0"; 41'-3"; 33'-0"
 ALONG ϕ 39'-3 1/4" ROADWAY
 @ STA 324+26.00

FOR DETAIL OF HMA TRANSITION
 SEE SHEET 60

LEGEND	
	HMA SURFACE REMOVAL - 3/4"
	HMA SURFACE REMOVAL - BUTT JOINT FOR DETAIL, SEE SHEET(S) 61

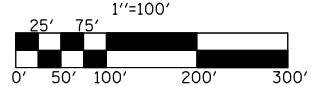

ILLINOIS DEPARTMENT OF TRANSPORTATION
PLAN VIEW
 F.A.I. ROUTE 57
 SECTION (15,21-25,21-26,27)RS-1
 DOUGLAS COUNTY
 SCALE: 1" = 100'
 DATE: 01/19/06
 DRAWN BY: J.P.
 CHECKED BY: K.D.

SEC. 15, T. 15 N., R. 8 E., 3RD P.M.

PLOT DATE = 8/21/2008
 FILE NAME = c:\p\projects\4501305 (v8)\100planshts.dgn
 PLOT SCALE = 211.7647' / IN.
 USER NAME = sheehyjm

F.A.I. RTE.	SECTION	COUNTY	TOTAL SHEETS	SHEET NO.
57	*	DOUGLAS	76	40
STA. 350+00		TO STA. 380+00		
FED. ROAD DIST. NO.		ILLINOIS	FED. AID PROJECT	
*(15,21-25,21-26,27)RS-1				

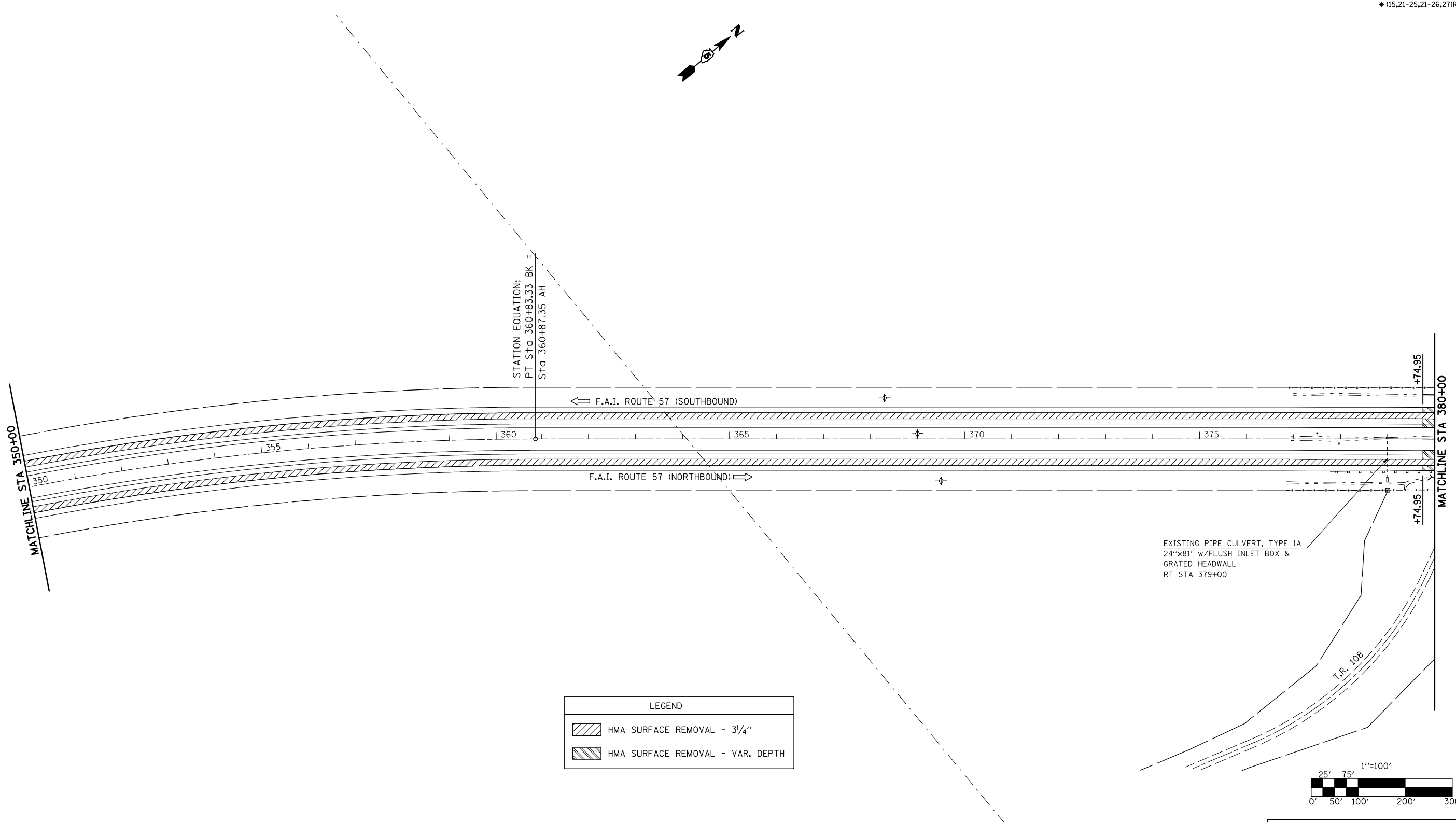
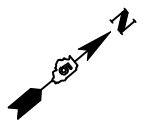

LEGEND	
	HMA SURFACE REMOVAL - 3/4"
	HMA SURFACE REMOVAL - VAR. DEPTH

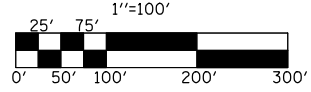

PLOT DATE = 8/21/2008
 FILE NAME = c:\projects\1521\100\plans\1521.dgn
 PLOT SCALE = 211.7647' / IN.
 USER NAME = sheehyjm

SEC. 15, T. 15 N., R. 8 E., 3RD P.M.

SEC. 10, T. 15 N., R. 8 E., 3RD P.M.

ILLINOIS DEPARTMENT OF TRANSPORTATION
PLAN VIEW
 F.A.I. ROUTE 57
 SECTION (15,21-25,21-26,27)RS-1
 DOUGLAS COUNTY

SCALE: 1" = 100'
 DATE: 01/19/06

DRAWN BY: J.P.
 CHECKED BY: K.D.

F.A.I. RTE.	SECTION	COUNTY	TOTAL SHEETS	SHEET NO.
57	*	DOUGLAS	76	41
STA. 380+00		TO STA. 410+00		
FED. ROAD DIST. NO.		ILLINOIS	FED. AID PROJECT	
* (15,21-25,21-26,27)RS-1				

SEC. 10, T. 15 N., R. 8 E., 3RD P.M.

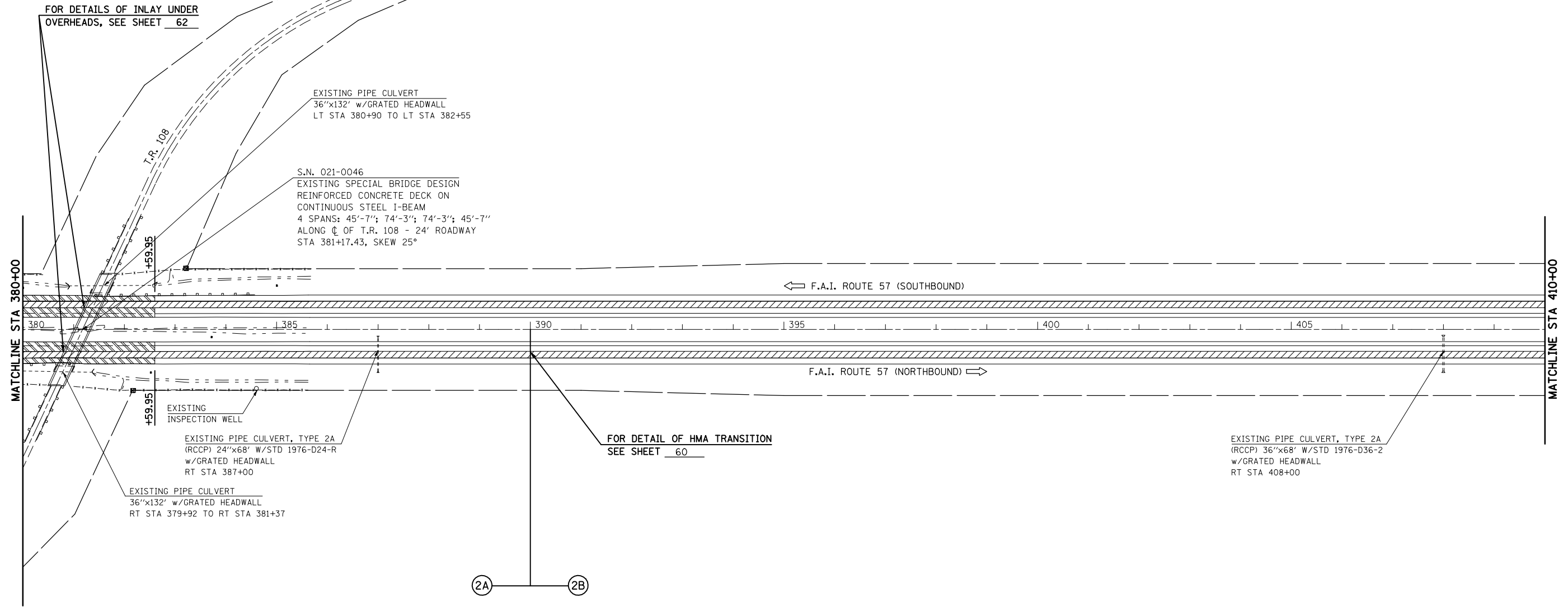
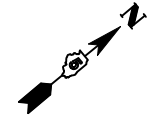

LEGEND	
	HMA SURFACE REMOVAL - 3/4"
	HMA SURFACE REMOVAL - VAR. DEPTH

SEC. 11, T. 15 N., R. 8 E., 3RD P.M.

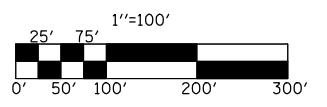

ILLINOIS DEPARTMENT OF TRANSPORTATION
PLAN VIEW
 F.A.I. ROUTE 57
 SECTION (15,21-25,21-26,27)RS-1
 DOUGLAS COUNTY

SCALE: 1" = 100'
 DATE: 01/19/06

DRAWN BY: J.P.
 CHECKED BY: K.D.

PLOT DATE = 8/21/2008
 FILE NAME = c:\projects\1501305 (v8)\100planshds.dgn
 PLOT SCALE = 211.7647 / IN.
 USER NAME = sheehyjm

F.A.I. RTE.	SECTION	COUNTY	TOTAL SHEETS	SHEET NO.
57	*	DOUGLAS	76	42
STA. 410+00		TO STA. 440+00		
FED. ROAD DIST. NO.		ILLINOIS	FED. AID PROJECT	
*(15,21-25,21-26,27)RS-1				

SEC. 2, T. 15 N., R. 8 E., 3RD P.M.

FOR DETAILS OF INLAY UNDER OVERHEADS, SEE SHEET 60&62

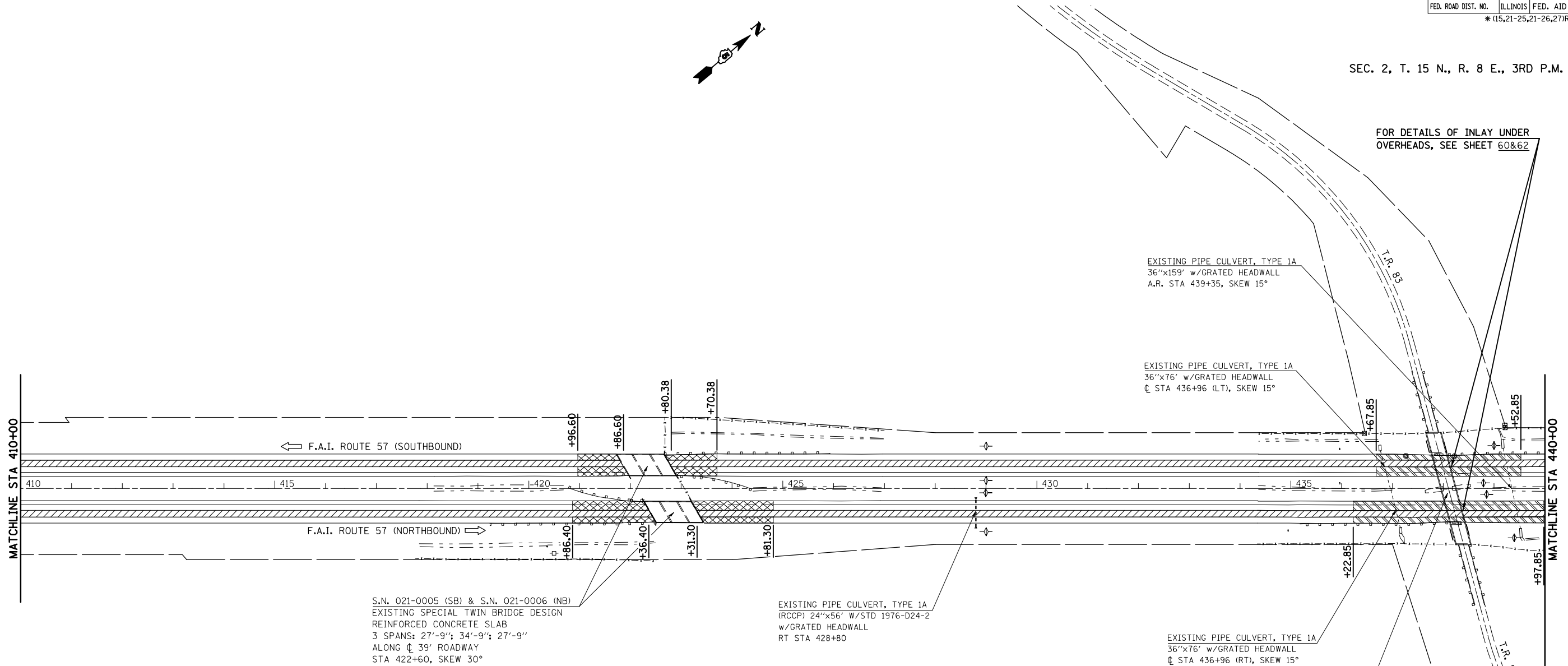

S.N. 021-0005 (SB) & S.N. 021-0006 (NB)
 EXISTING SPECIAL TWIN BRIDGE DESIGN
 REINFORCED CONCRETE SLAB
 3 SPANS: 27'-9"; 34'-9"; 27'-9"
 ALONG ϕ 39' ROADWAY
 STA 422+60, SKEW 30°

EXISTING PIPE CULVERT, TYPE 1A
 (RCCP) 24"x56' W/STD 1976-D24-2
 w/GRATED HEADWALL
 RT STA 428+80

EXISTING PIPE CULVERT, TYPE 1A
 36"x76' w/GRATED HEADWALL
 ϕ STA 436+96 (RT), SKEW 15°

S.N. 021-0045
 EXISTING SPECIAL BRIDGE DESIGN
 REINFORCED CONCRETE DECK ON
 CONTINUOUS STEEL I-BEAMS
 4 SPANS: 42'-5"; 69'-8"; 42'-5"
 ALONG ϕ T.R. 83 - 24' ROADWAY
 STA 438+09.35, SKEW 15°

LEGEND	
	HMA SURFACE REMOVAL - 3/4"
	HMA SURFACE REMOVAL - VAR. DEPTH
	HMA SURFACE REMOVAL - BUTT JOINT FOR DETAIL, SEE SHEET(S) 61

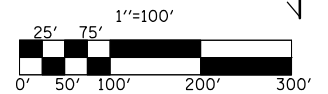

SEC. 11, T. 15 N., R. 8 E., 3RD P.M.

ILLINOIS DEPARTMENT OF TRANSPORTATION
PLAN VIEW
 F.A.I. ROUTE 57
 SECTION (15,21-25,21-26,27)RS-1
 DOUGLAS COUNTY

SCALE: 1" = 100'
 DATE: 01/19/06

DRAWN BY: J.P.
 CHECKED BY: K.D.

F.A.I. RTE.	SECTION	COUNTY	TOTAL SHEETS	SHEET NO.
57	*	DOUGLAS	76	43
STA. 440+00		TO STA. 470+00		
FED. ROAD DIST. NO.		ILLINOIS	FED. AID PROJECT	
*(15,21-25,21-26,27)RS-1				

SEC. 2, T. 15 N., R. 8 E., 3RD P.M.

EXIST. CURVE DATA
 PI STA. = 464+90.35
 $\Delta = 40^\circ 31' 30''$ (LT)
 $D = 1^\circ 30' 00''$
 $R = 3,819.72'$
 $T = 1,410.12'$
 $L = 2,701.67'$
 $E = 251.97'$
 $e = \text{-----}$
 $T.R. = \text{-----}$
 $S.E. \text{ RUN} = \text{-----}$
 $P.C. \text{ STA.} = 450+80.23$
 $P.T. \text{ STA.} = 477+81.90$

S.N. 021-0007 (NB) & S.N. 021-0008 (SB)
 EXISTING SPECIAL TWIN BRIDGE DESIGN
 REINFORCED CONCRETE SLAB
 3 SPANS: 33'-0"; 41'-6"; 33'-0"
 ALONG C OF 39' ROADWAY
 STA 464+00, SKEW 30°

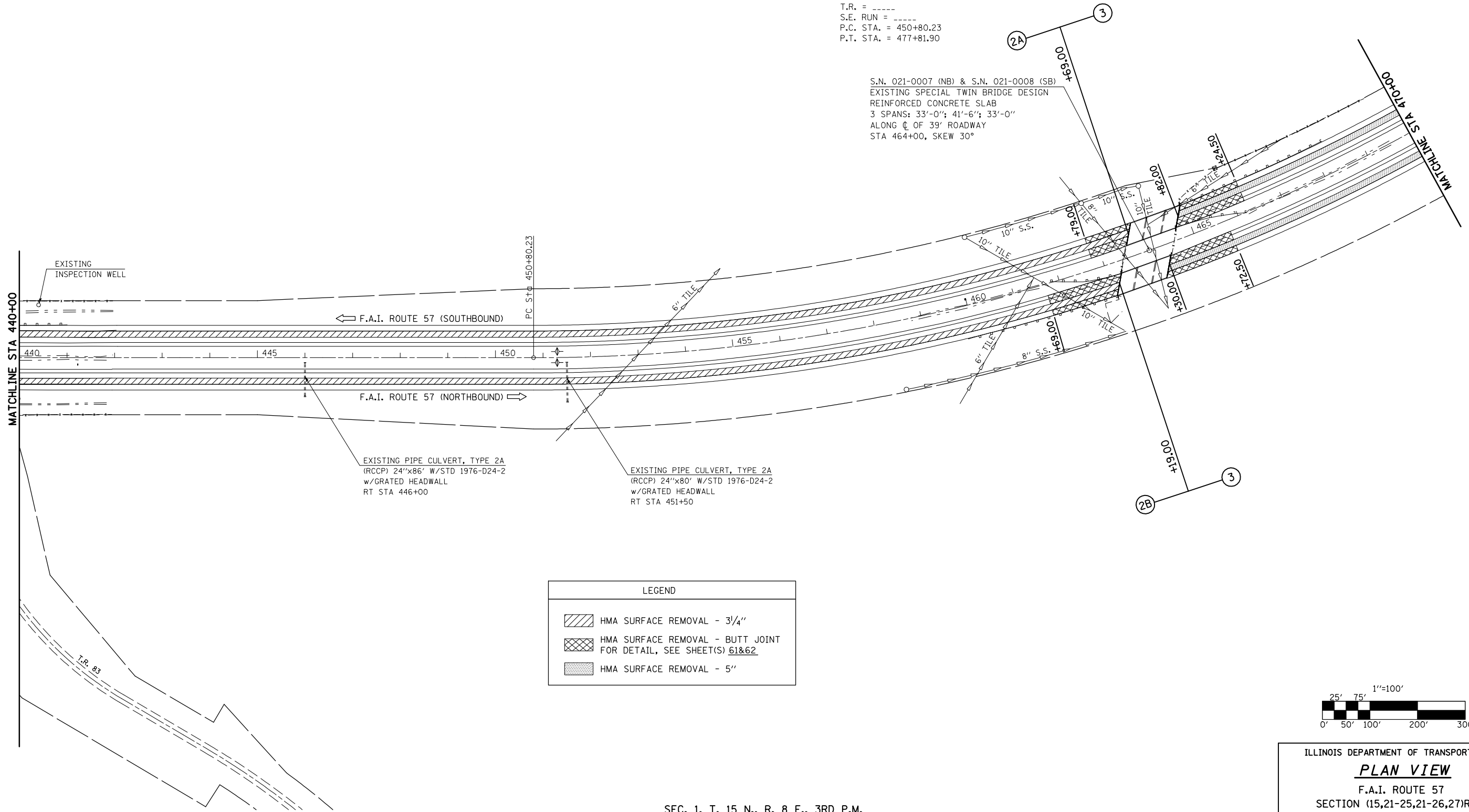

LEGEND	
	HMA SURFACE REMOVAL - 3 1/4"
	HMA SURFACE REMOVAL - BUTT JOINT FOR DETAIL, SEE SHEET(S) 61&62
	HMA SURFACE REMOVAL - 5"

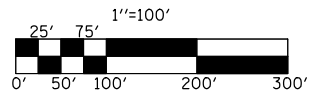

ILLINOIS DEPARTMENT OF TRANSPORTATION
PLAN VIEW
 F.A.I. ROUTE 57
 SECTION (15,21-25,21-26,27)RS-1
 DOUGLAS COUNTY
 SCALE: 1" = 100'
 DATE: 01/19/06
 DRAWN BY: J.P.
 CHECKED BY: K.D.

SEC. 1, T. 15 N., R. 8 E., 3RD P.M.

PLOT DATE = 8/21/2008
 FILE NAME = c:\projects\1501305 (v8)\100plans\shs.dgn
 PLOT SCALE = 211.7647' / IN.
 USER NAME = sheehyjm

F.A.I. RTE.	SECTION	COUNTY	TOTAL SHEETS	SHEET NO.
57	*	DOUGLAS	76	44
STA. 470+00		TO STA. 500+00		
FED. ROAD DIST. NO.	ILLINOIS	FED. AID PROJECT		
* (15,21-25,21-26,27)RS-1				



SEC. 2, T. 15 N., R. 8 E., 3RD P.M.

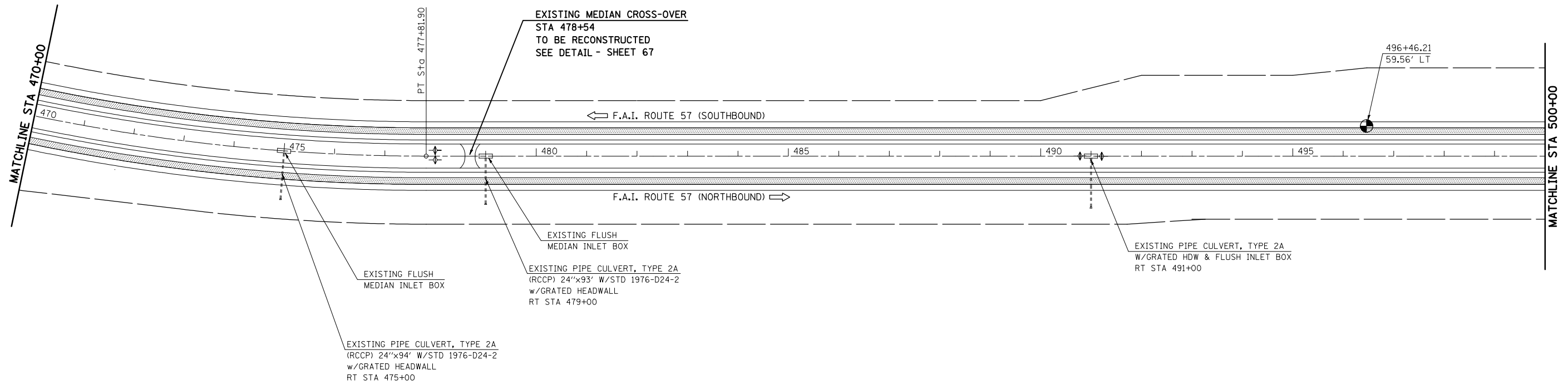

LEGEND	
	HMA SURFACE REMOVAL - 5"

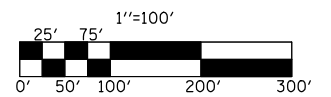

SEC. 1, T. 15 N., R. 8 E., 3RD P.M.

ILLINOIS DEPARTMENT OF TRANSPORTATION
PLAN VIEW
 F.A.I. ROUTE 57
 SECTION (15,21-25,21-26,27)RS-1
 DOUGLAS COUNTY

SCALE: 1" = 100'
 DATE: 01/19/06

DRAWN BY: J.P.
 CHECKED BY: K.D.

F.A.I. RTE.	SECTION	COUNTY	TOTAL SHEETS	SHEET NO.
57	*	DOUGLAS	76	45
STA. 500+00		TO STA. 527+00		
FED. ROAD DIST. NO.		ILLINOIS	FED. AID PROJECT	
*(15,21-25,21-26,27)RS-1				

EXIST. CURVE 36RMPB-1 PI STA. = 102+31.11 Δ = 16° 14' 11" (RT) D = 8° 18' 00" R = 690.31' T = 98.47' L = 195.62' E = 6.99' e = ---- T.R. = ---- S.E. RUN = ---- P.C. STA. = 101+32.64 P.T. STA. = 103+28.26	EXIST. CURVE 36RMPB-2 PI STA. = 104+04.99 Δ = 20° 13' 26" (RT) D = 13° 19' 00" R = 430.26' T = 76.73' L = 151.87' E = 6.79' e = ---- T.R. = ---- S.E. RUN = ---- P.C. STA. = 103+28.26 P.T. STA. = 104+80.13	EXIST. CURVE 36RMPB-3 PI STA. = 110+78.96 Δ = 140° 30' 09" (RT) D = 26° 39' 02" R = 214.99' T = 598.84' L = 527.20' E = 421.27' e = ---- T.R. = ---- S.E. RUN = ---- P.C. STA. = 104+80.13 P.T. STA. = 110+07.33
---	--	--

EXIST. CURVE 36RMPA-1 PI STA. = 9+92.62 Δ = 62° 05' 46" (LT) D = 19° 49' 34" R = 288.99' T = 173.97' L = 313.20' E = 48.33' e = ---- T.R. = ---- S.E. RUN = ---- P.C. STA. = 8+18.65 P.T. STA. = 11+31.85	EXIST. CURVE 36RMPA-2 PI STA. = 16+07.07 Δ = 60° 57' 26" (RT) D = 13° 19' 00" R = 430.26' T = 253.23' L = 457.75' E = 68.99' e = ---- T.R. = ---- S.E. RUN = ---- P.C. STA. = 13+53.84 P.T. STA. = 18+11.60
---	---



SEC. 2, T. 15 N., R. 8 E., 3RD P.M.

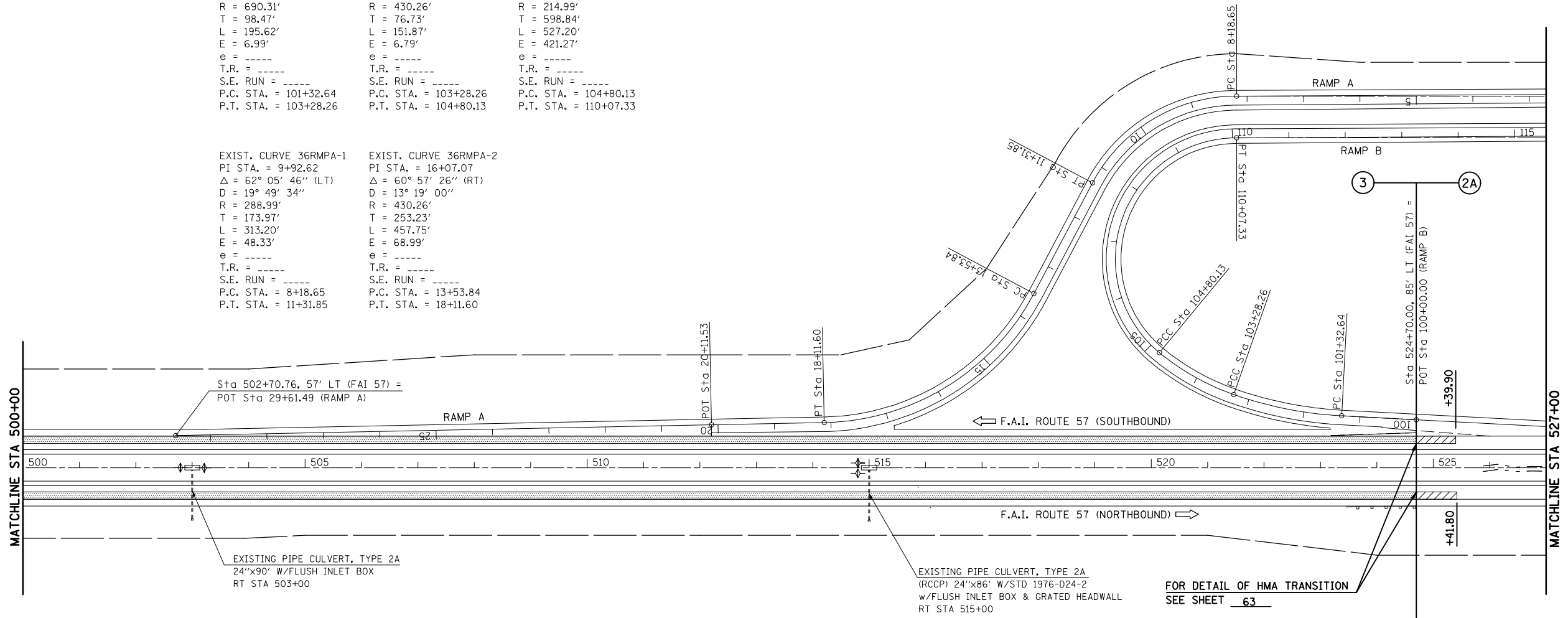

LEGEND	
	HMA SURFACE REMOVAL - 3/4"
	HMA SURFACE REMOVAL - 5"

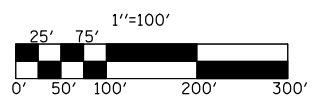

SEC. 1, T. 15 N., R. 8 E., 3RD P.M.

ILLINOIS DEPARTMENT OF TRANSPORTATION
PLAN VIEW
 F.A.I. ROUTE 57
 SECTION (15,21-25,21-26,27)RS-1
 DOUGLAS COUNTY

SCALE: 1" = 100'
 DATE: 01/19/06

DRAWN BY: J.P.
 CHECKED BY: K.D.

PLOT DATE = 8/21/2008
 FILE NAME = c:\p\projects\4501305 (v8)\100plans\shs.dgn
 PLOT SCALE = 211.7647' / IN.
 USER NAME = sheehyjm

F.A.I. RTE.	SECTION	COUNTY	TOTAL SHEETS	SHEET NO.
57	*	DOUGLAS	76	46
STA. 527+00		TO STA. 559+00		
FED. ROAD DIST. NO.		ILLINOIS FED. AID PROJECT		
* (15,21-25,21-26,27)RS-1				

SEC. 35, T. 16 N., R. 8 E., 3RD P.M.



LEGEND	
	HMA SURFACE REMOVAL - 3/4"
	HMA SURFACE REMOVAL - BUTT JOINT FOR DETAIL, SEE SHEET(S) 63&64

SECTION (15,21-25,21-26,27)RS-1 ENDS STATION 547+00.00

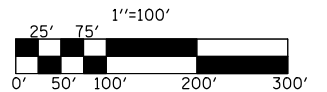
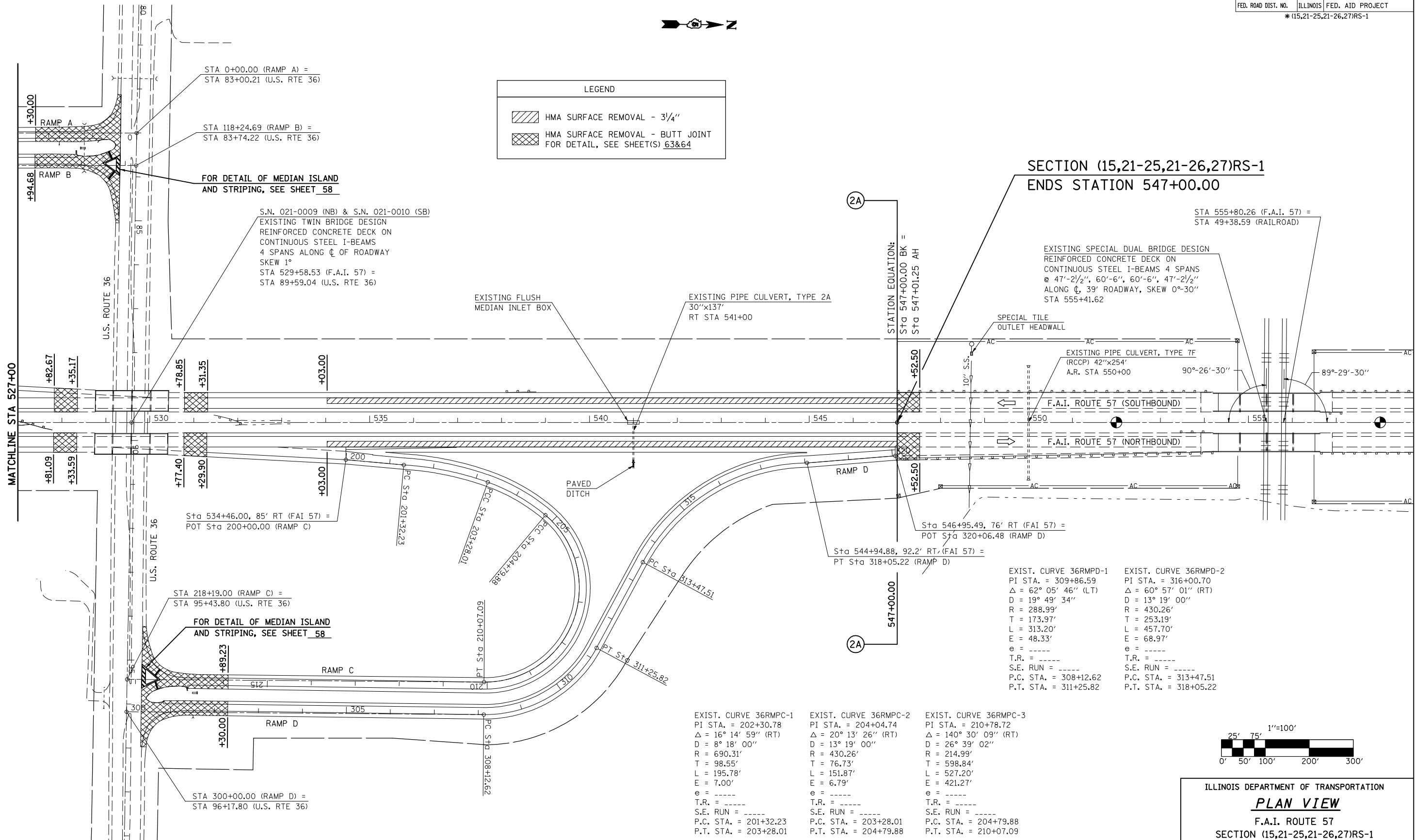

ILLINOIS DEPARTMENT OF TRANSPORTATION
PLAN VIEW
 F.A.I. ROUTE 57
 SECTION (15,21-25,21-26,27)RS-1
 DOUGLAS COUNTY

SCALE: 1" = 100'
 DATE: 01/19/06
 DRAWN BY: J.P.
 CHECKED BY: K.D.

SEC. 35, T. 16 N., R. 8 E., 3RD P.M.

PLOT DATE = 8/21/2008
 FILE NAME = c:\p\projects\0801305 (v8)\100plan\shs.dgn
 PLOT SCALE = 211.7647' / IN.
 USER NAME = sheehyjm

F.A.I. RTE.	SECTION	COUNTY	TOTAL SHEETS	SHEET NO.
57	*	DOUGLAS	76	47

* (15,21-25,21-26,27)RS-1

GENERAL PLAN AND ELEVATION

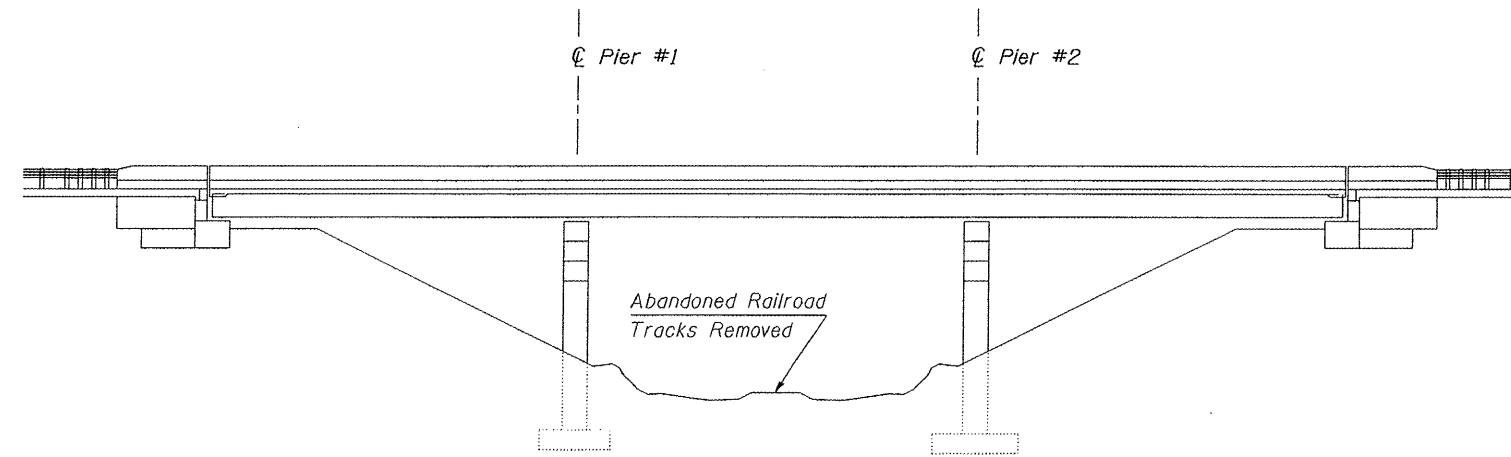

ELEVATION

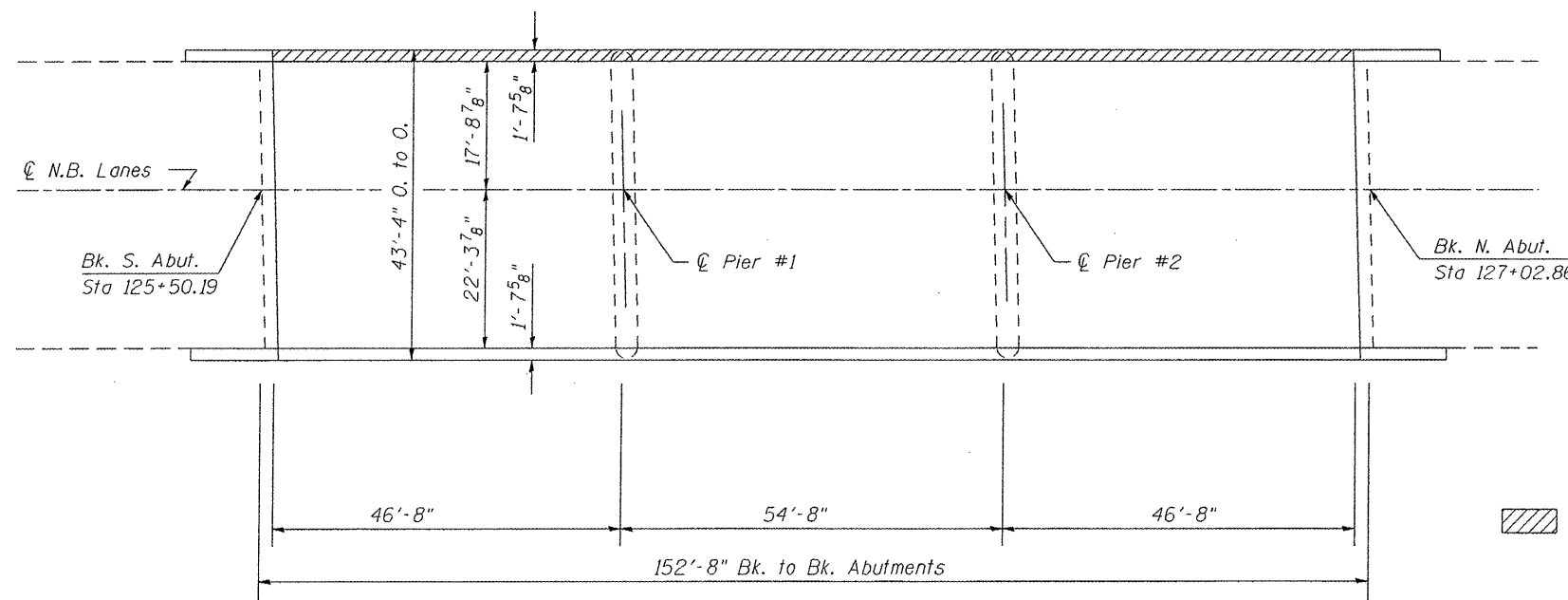
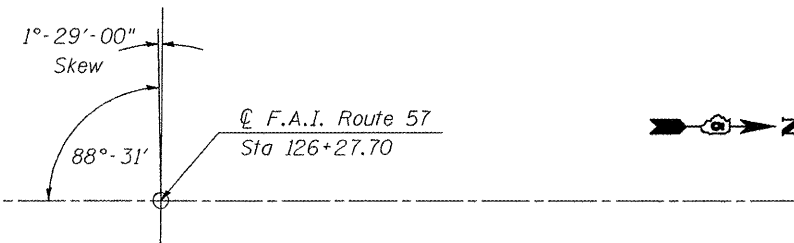

PLAN
S.N. 021-0001 N.B.

Plan dimensions and details relative to existing plans are subject to routine variations. The Contractor shall field verify existing dimensions and details affecting new construction and make necessary approved adjustments prior to construction or ordering of materials. Such variations shall not be cause for additional compensation for a change in the scope of work, however, the Contractor will be paid for the quantity actually furnished based upon the unit price bid for the work.

Existing reinforcement bars extending into the removal area shall be cleaned, straightened and incorporated into the new construction. Any reinforcement bars that are damaged during concrete removal shall be replaced with an approved bar splicer or anchorage system. Cost included with Concrete Removal.

Reinforcement bars shall conform to the requirements of ASTM A 706 GR 60. See Special Provisions.

Reinforcement bars designated (E) shall be epoxy coated.

TOTAL BILL OF MATERIAL

ITEM	UNIT	QUANTITY
Concrete Removal	Cu Yd	15.9
Concrete Superstructure	Cu Yd	15.9
Protective Coat	Sq Yd	58.0
Reinforcement Bars, Epoxy Coated	Pound	2,590

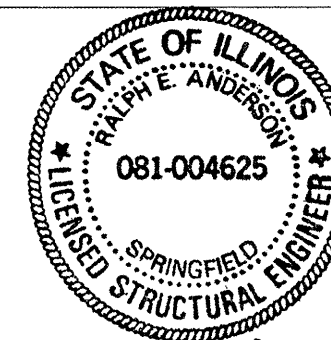

Ralph E. Anderson
Expires Nov. 30, 2008

F.A.I. 57 OVER
ABANDONED RAILROAD
SECTION 21-26VB
DOUGLAS COUNTY
S.N. 021-0001 N.B.

SHEET 1 OF 5

Hatched area indicates removal of existing concrete parapet.

ILLINOIS DEPARTMENT OF TRANSPORTATION
GENERAL PLAN AND ELEVATION
F.A.I. ROUTE 57
SECTION (15,21-25,21-26,27)RS-1
DOUGLAS COUNTY
SCALE: NOT TO SCALE
DATE: 02/14/08
DRAWN BY: J.P.
CHECKED BY: K.D.

F.A.I. RTE.	SECTION	COUNTY	TOTAL SHEETS	SHEET NO.
57	*	DOUGLAS	76	48

*(15,21-25,21-26,27)RS-1

EXISTING TYPICAL SECTION
S.N. 021-0001
(N.B. LOOKING NORTH)

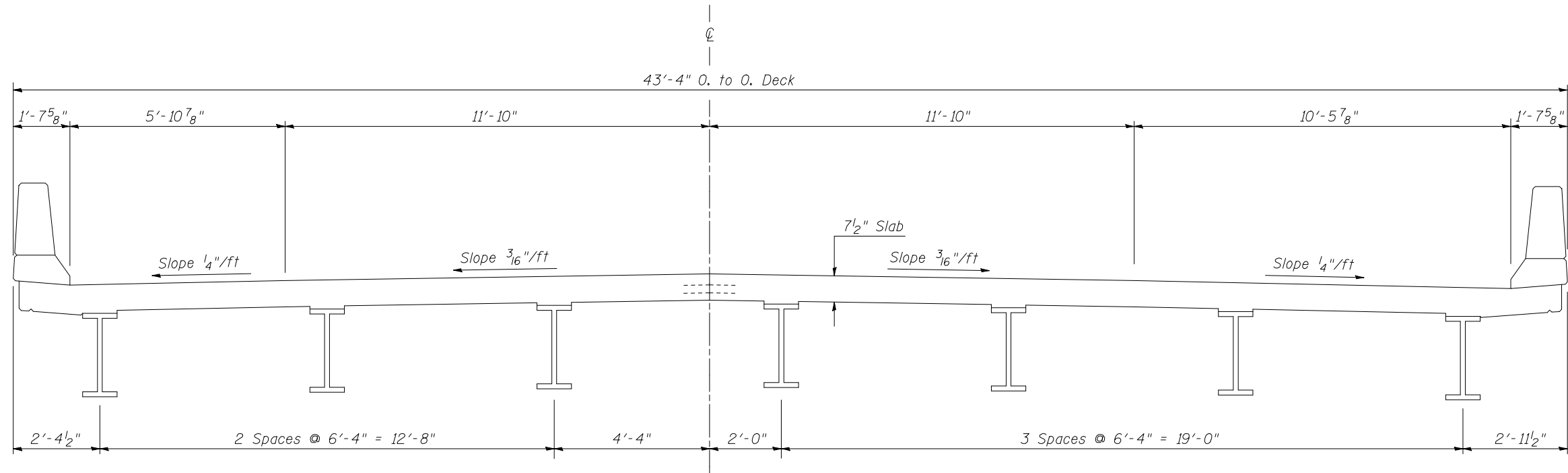

EXISTING

F.A.I. 57 OVER
 ABANDONED RAILROAD
 SECTION 21-26VB
 DOUGLAS COUNTY
 S.N. 021-0001 N.B.

SHEET 2 OF 5

ILLINOIS DEPARTMENT OF TRANSPORTATION
EXISTING
TYPICAL SECTION
 F.A.I. ROUTE 57
 SECTION (15,21-25,21-26,27)RS-1
 DOUGLAS COUNTY

SCALE: NOT TO SCALE DRAWN BY: J.P.
 DATE: 02/14/08 CHECKED BY: K.D.

PLOT DATE = 8/21/2008
 FILE NAME = c:\projects\70465\70465.dwg
 PLOT SCALE = 1/8" = 1'-0"
 USER NAME = sheehyjm

F.A.I. RTE.	SECTION	COUNTY	TOTAL SHEETS	SHEET NO.
57	*	DOUGLAS	76	49

* (15,21-25,21-26,27)RS-1

TRAFFIC CONTROL PLAN

Z0030250 IMPACT ATTENUATORS, TEMPORARY
(NON-REDIRECTIVE), TEST LEVEL 3

STATION	OFFSET	EACH
123+75.52	12.47' LT	1.0
TOTAL		= 1.0

70400100 TEMPORARY CONCRETE BARRIER

STATION	OFFSET	TO	STATION	OFFSET	FOOT
123+75.52	12.47' LT		127+37.50	0.125' LT	362.5
TOTAL					= 362.5

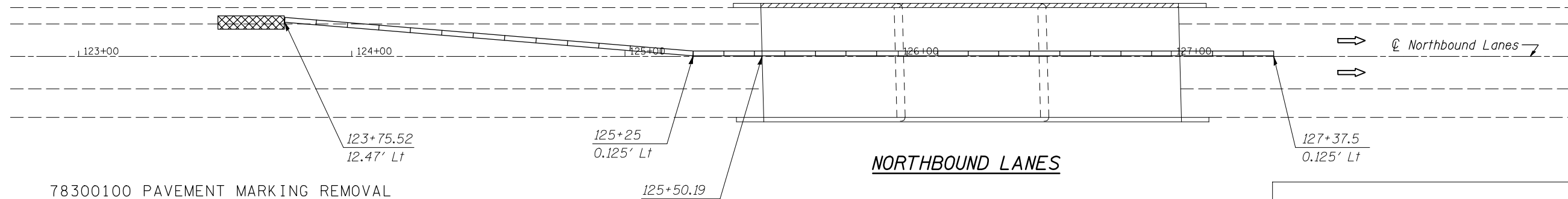

78300100 PAVEMENT MARKING REMOVAL

STATION	TO	STATION		SQ FT
123+75.52		127+37.50	4" SOLID WHITE	120.7
118+75.52		125+25.00	4" SKIP DASH	54.2
TOTAL				= 174.9

70300100 SHORT TERM PAVEMENT MARKING

STATION	TO	STATION		FOOT
118+75.52		125+25.00	4" SKIP DASH	65.0
123+75.52		125+20.19	DR. SHOULDER	5.8
TOTAL				= 70.8

70301000 WORK ZONE PAVEMENT MARKING REMOVAL

STATION	TO	STATION		SQ FT
123+75.52		127+37.50	4" SOLID WHITE	120.7
1501+52.05		127+37.50	4" SOLID YELLOW	620.7
TOTAL				= 741.4

78001110 PAINT PAVEMENT MARKING-LINE 4"

STATION	TO	STATION		FOOT
125+20.19		127+37.50	DR. SHOULDER	217.3
TOTAL				= 217.3

STATION EQUATION:
STA 1510+00.00 BK = STA 117+23.47 AH

Notes:

Traffic details not shown are to conform with Standard 701400 and 701402.

Raised Reflective Pavement Markers affected by the proposed traffic control plan will be covered in a suitable manner and approved by the Resident Engineer. This cost will be included in the appropriate Traffic Control pay item for Standard 704102.

Type C Monodirectional Reflectors will be added to the existing parapet and guardrail, see Standard 701402, Note ② for proper placement.

Notes:

Hatched area indicates removal of existing concrete parapet.

For details and setup of Temporary Concrete Barrier, See Highway Standards 704001-04 and 701402-06.

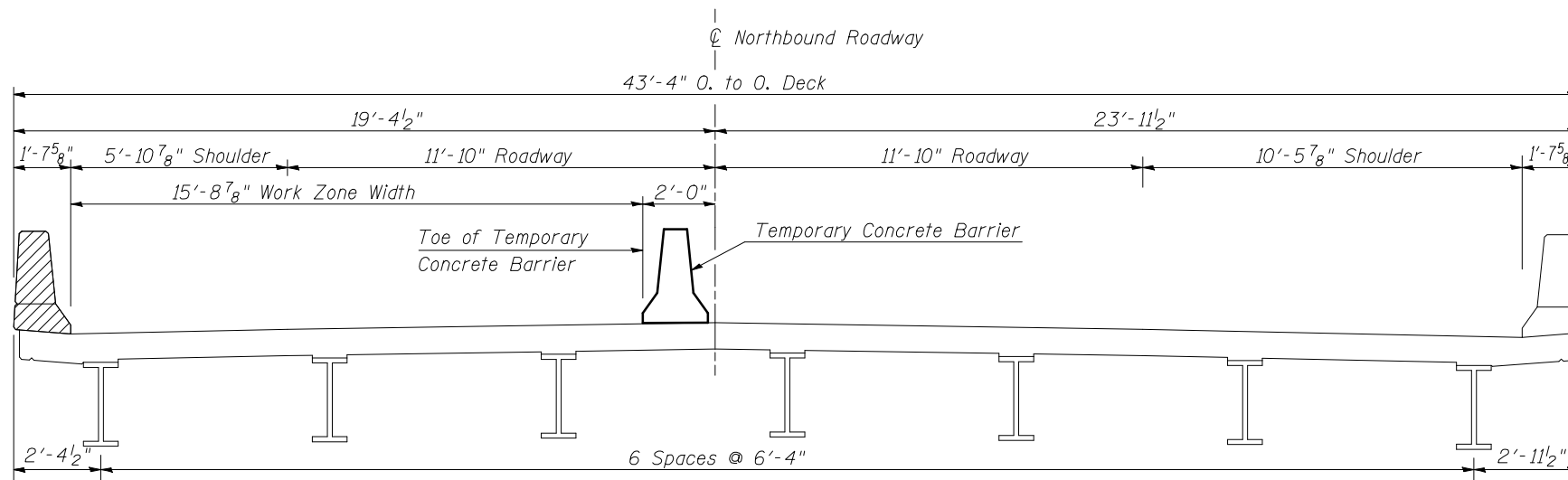

**F.A.I. 57 OVER
ABANDONED RAILROAD
SECTION 21-26VB
DOUGLAS COUNTY
S.N. 021-0001 N.B.**

SHEET 3 OF 5

ILLINOIS DEPARTMENT OF TRANSPORTATION

TRAFFIC CONTROL PLAN

F.A.I. ROUTE 57
SECTION (15,21-25,21-26,27)RS-1
DOUGLAS COUNTY

SCALE: NOT TO SCALE
DATE: 02/14/08

DRAWN BY: J.P.
CHECKED BY: K.D.

F.A.I. RTE.	SECTION	COUNTY	TOTAL SHEETS	SHEET NO.
57	*	DOUGLAS	76	50

*(15,21-25,21-26,27)RS-1

PARAPET DETAILS

BAR LIST

Bar	No.	Size	Length	Shape
d(E)	150	#4	3'-0"	┌
d ₁ (E)	163	#5	3'-0"	┌
e(E)	36	#4	20'-11"	—
e ₁ (E)	12	#8	21'-11"	—
e ₂ (E)	24	#4	6'-9"	—
e ₃ (E)	8	#8	6'-9"	—
e ₄ (E)	12	#5	21'-1"	—
e ₅ (E)	8	#5	6'-9"	—

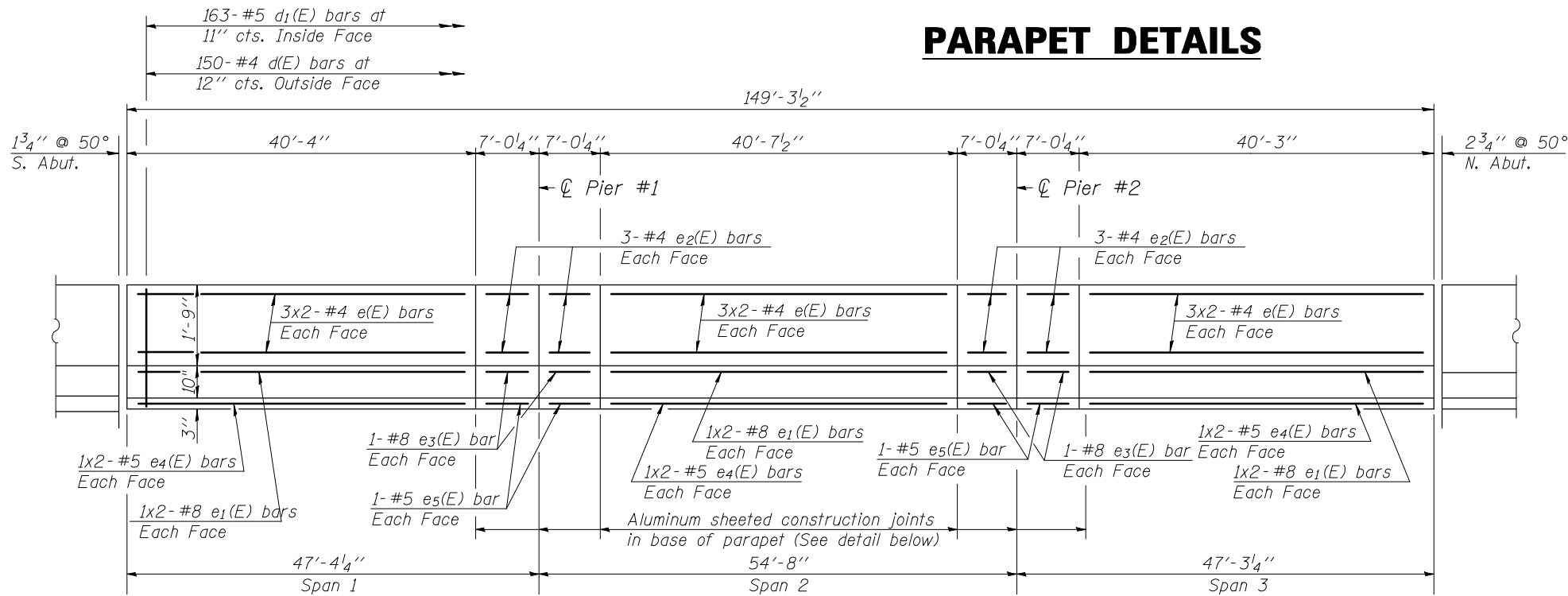

INSIDE ELEVATION OF PARAPET

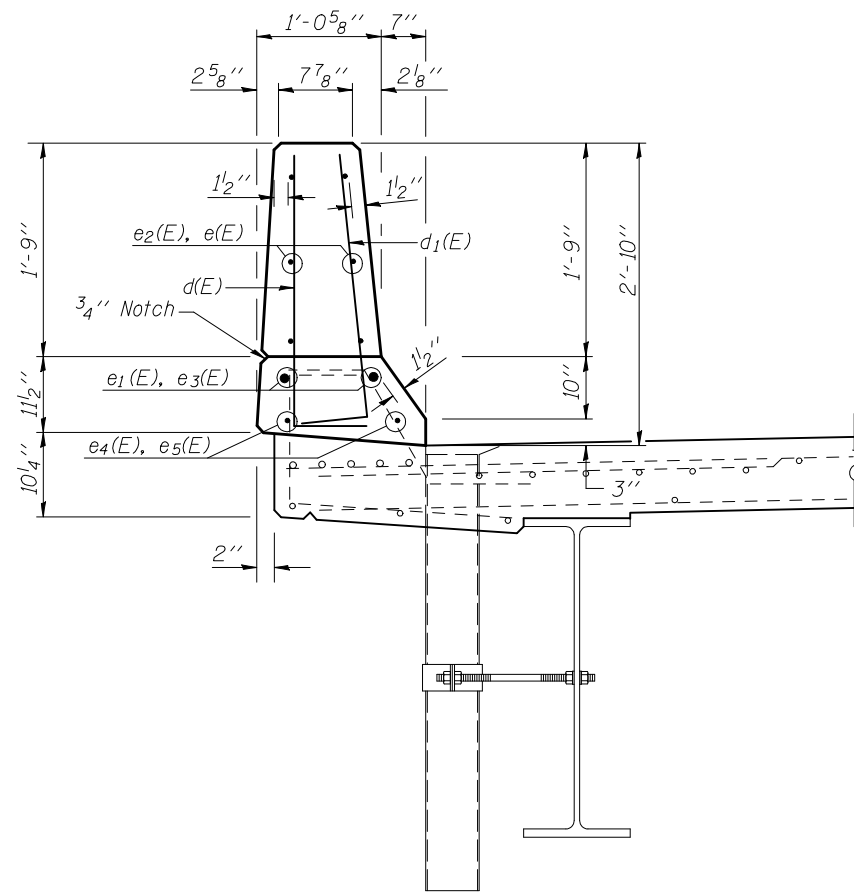

SECTION THRU PARAPET

MINIMUM BAR LAPS

- #4 bar = 1'-4"
- #8 bar = 3'-5"
- #5 bar = 1'-8"

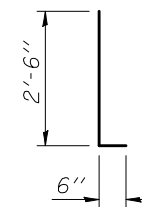

BAR d(E) & d₁(E)

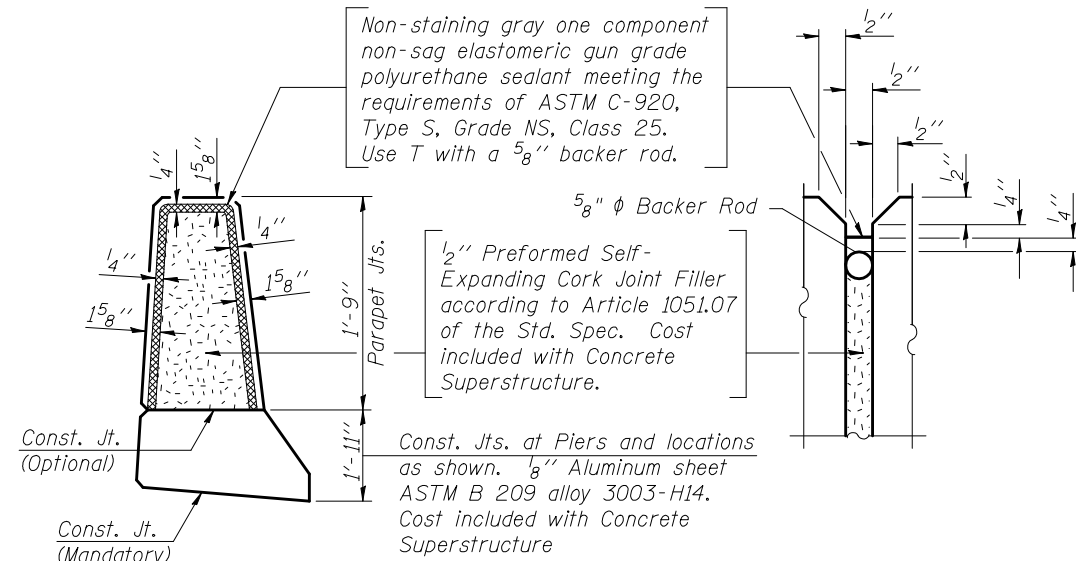

PARAPET JOINT DETAILS

Notes:

Reinforcement bars shall not pass through aluminum sheets.

Preformed Joint Seals and steel plates at the ends of the parapet shall be saved and reused. See Joint Details on Sheet 5 of 5.

BILL OF MATERIAL

ITEM	UNIT	QUANTITY
Concrete Removal	Cu Yd	15.9
Concrete Superstructure	Cu Yd	15.9
Protective Coat	Sq Yd	58.0
Reinforcement Bars, Epoxy Coated	Pound	2,590

Bars indicated thus 1x2- #8 etc., indicates 1 line of bars with 2 lengths per line.

F.A.I. 57 OVER
 ABANDONED RAILROAD
 SECTION 21-26V
 DOUGLAS COUNTY
 S.N. 021-0001 N.B.

SHEET 4 OF 5

ILLINOIS DEPARTMENT OF TRANSPORTATION

PARAPET DETAILS

F.A.I. ROUTE 57
 SECTION (15,21-25,21-26,27)RS-1
 DOUGLAS COUNTY

SCALE: NOT TO SCALE
 DATE: 02/14/08

DRAWN BY: J.P.
 CHECKED BY: K.D.

CONTRACT NO. 70465				
F.A.I. RTE.	SECTION	COUNTY	TOTAL SHEETS	SHEET NO.
57	*	DOUGLAS	76	51

* (15,21-25,21-26,27)RS-1

EXISTING JOINT DETAILS

FOR INFORMATION ONLY

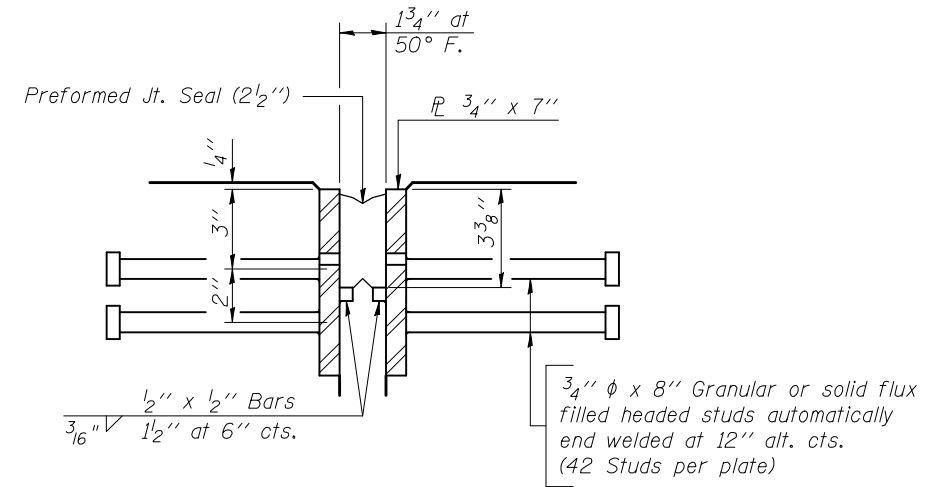

DETAIL SOUTH EXPANSION JOINT

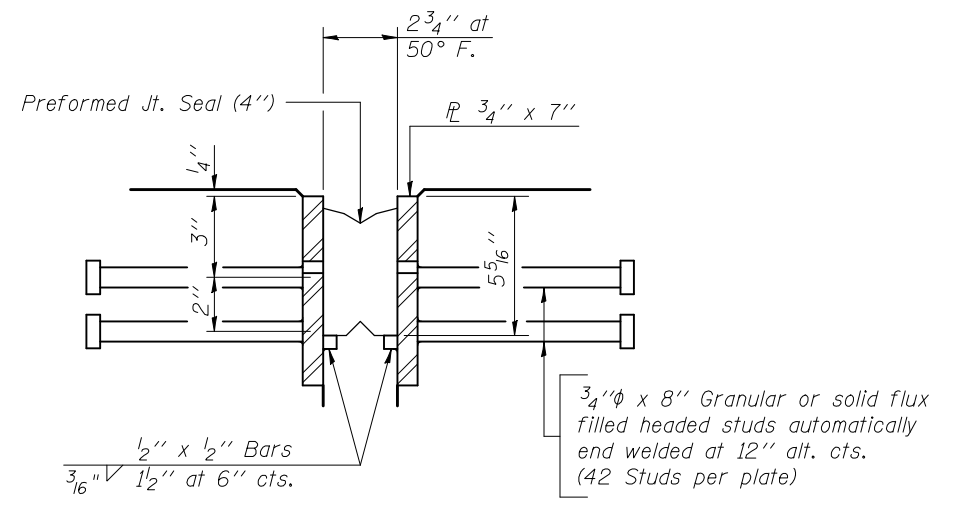

DETAIL NORTH EXPANSION JOINT

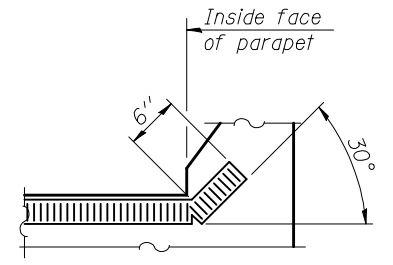

END TREATMENT THRU PARAPET

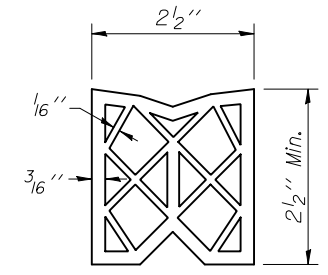

PREFORMED JOINT SEAL (2 1/2") AT SOUTH JOINT

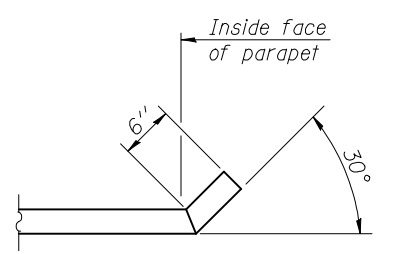

END OF STEEL PLATE THRU PARAPET

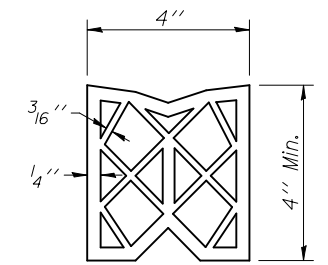

PREFORMED JOINT SEAL (4") AT NORTH JOINT

Notes:
 Steel plates at the ends of the parapets shall be saved and reused. The preformed joint seals may be partially removed as necessary to complete the proposed work. Reattach the preformed joint seals according to Article 520.06 of the Std. Specs. Cost included with Concrete Superstructure

F.A.I. 57 OVER
 ABANDONED RAILROAD
 SECTION 21-26VB
 DOUGLAS COUNTY
 S.N. 021-0001 N.B.

SHEET 5 OF 5

ILLINOIS DEPARTMENT OF TRANSPORTATION
EXISTING JOINT DETAILS
 F.A.I. ROUTE 57
 SECTION (15,21-25,21-26,27)RS-1
 DOUGLAS COUNTY

SCALE: NOT TO SCALE
 DATE: 02/14/08
 DRAWN BY: J.P.
 CHECKED BY: K.D.

PLOT DATE = 8/21/2008
 FILE NAME = c:\projects\1521-26vb\1521-26vb.dgn
 PLOT SCALE = 1/8" = 1'-0"
 USER NAME = sheehyjm

F.A.I. RTE.	SECTION	COUNTY	TOTAL SHEETS	SHEET NO.
57	*	DOUGLAS	76	52

* (15,21-25,21-26,27)RS-1

GENERAL PLAN

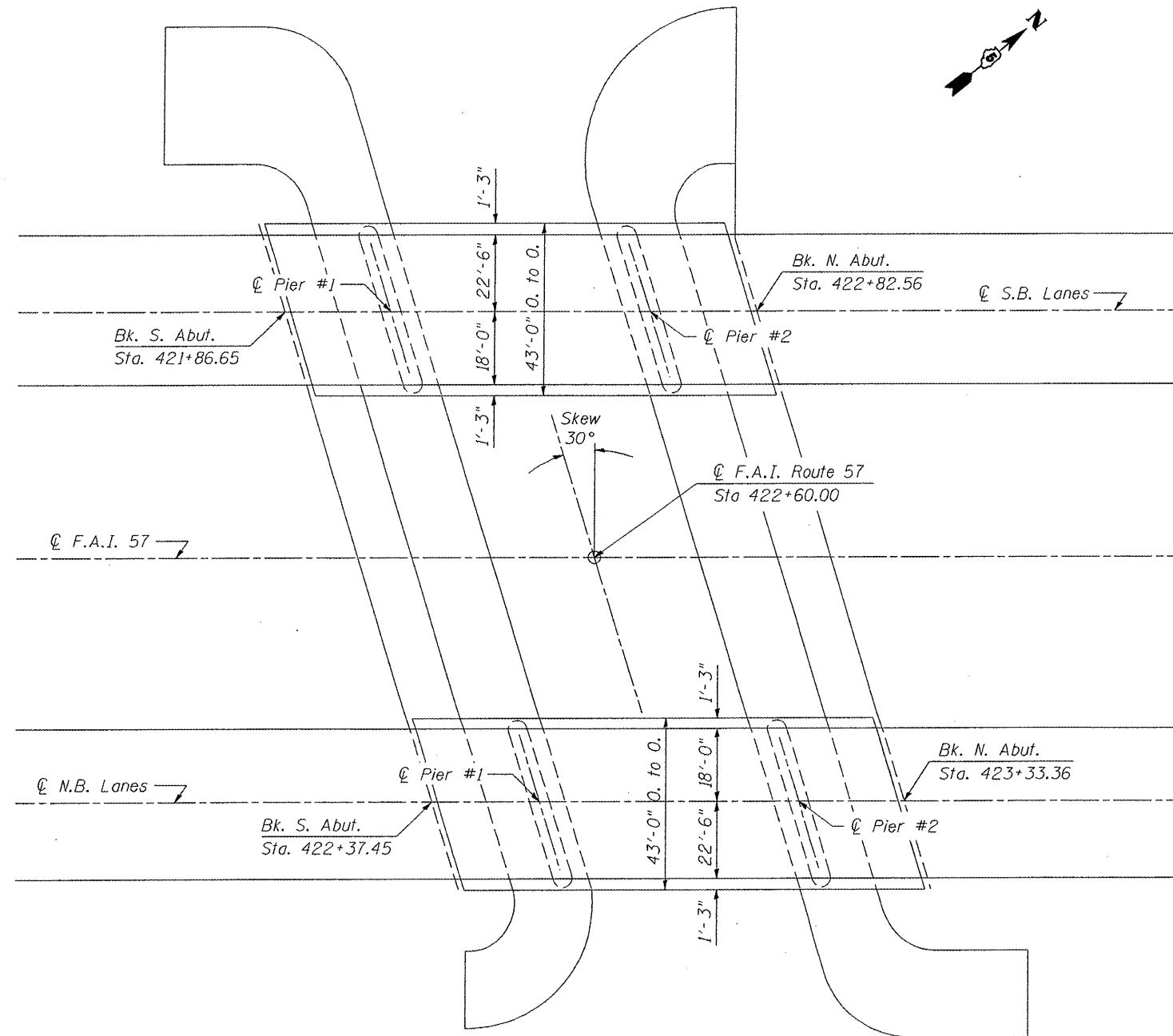

Plan dimensions and details relative to existing plans are subject to routine variations. The Contractor shall field verify existing dimensions and details affecting new construction and make necessary approved adjustments prior to construction or ordering of materials. Such variations shall not be cause for additional compensation for a change in the scope of work, however, the Contractor will be paid for the quantity actually furnished based upon the unit price bid for the work.

TOTAL BILL OF MATERIAL		
ITEM	UNIT	QUANTITY
Deck Slab Repair (Partial)	Sq Yd	14.0

PLAN
S.N. 021-0006 N.B. &
S.N. 021-0005 S.B.

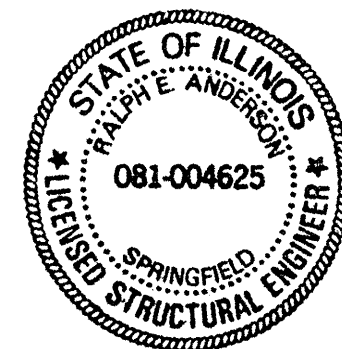

Ralph E. Anderson
 Expires Nov. 30, 2008

F.A.I. 57 OVER DRAINAGE DITCH
 SECTION 21-27B-1
 DOUGLAS COUNTY
 S.N. 021-0006 N.B. &
 S.N. 021-0005 S.B.

SHEET 1 OF 3

ILLINOIS DEPARTMENT OF TRANSPORTATION
GENERAL PLAN
 F.A.I. ROUTE 57
 SECTION (15,21-25,21-26,27)RS-1
 DOUGLAS COUNTY
 SCALE: NOT TO SCALE
 DATE: 03/12/08
 DRAWN BY: J.P.
 CHECKED BY: K.D.

PLOT DATE = 8/21/2008
 PLOT SCALE = 1/8" = 1'-0"
 USER NAME = shenjun

F.A.I. RTE.	SECTION	COUNTY	TOTAL SHEETS	SHEET NO.
57	*	DOUGLAS	76	53

*(15,21-25,21-26,27)RS-1

EXISTING TYPICAL SECTION
S.N. 021-0006 **S.N. 021-0005**
(N.B. LOOKING NORTH) **(S.B. LOOKING SOUTH)**

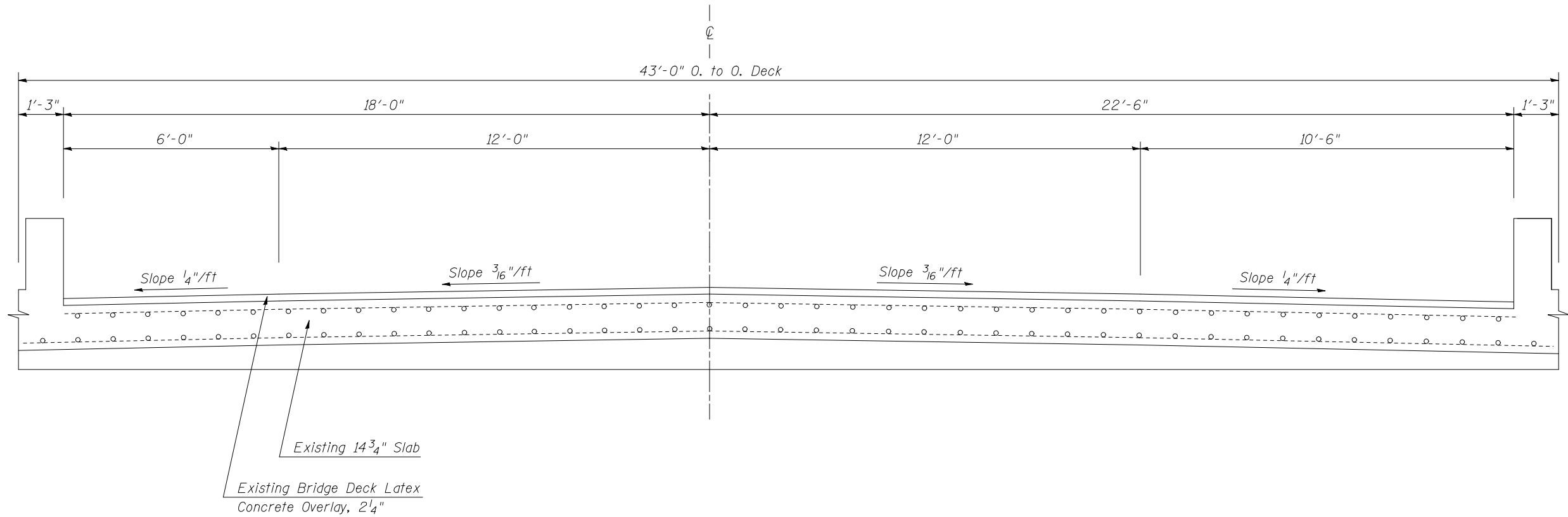

EXISTING

F.A.I. 57 OVER DRAINAGE DITCH
SECTION 21-27B-1
DOUGLAS COUNTY
S.N. 021-0006 N.B. &
S.N. 021-0005 S.B.

SHEET 2 OF 3

ILLINOIS DEPARTMENT OF TRANSPORTATION
EXISTING
TYPICAL SECTION
F.A.I. ROUTE 57
SECTION (15,21-25,21-26,27)RS-1
DOUGLAS COUNTY

SCALE: NOT TO SCALE DRAWN BY: J.P.
DATE: 03/12/08 CHECKED BY: K.D.

PLOT DATE = 8/21/2008
FILE NAME = c:\projects\70465\70465\70465.dgn
PLOT SCALE = 1/8" = 1'-0"
USER NAME = sheehyjm

F.A.I. RTE.	SECTION	COUNTY	TOTAL SHEETS	SHEET NO.
57	*	DOUGLAS	76	54

*(15,21-25,21-26,27)RS-1

DECK REPAIR

S.N. 021-0006 N.B. & S.N. 021-0005 S.B.

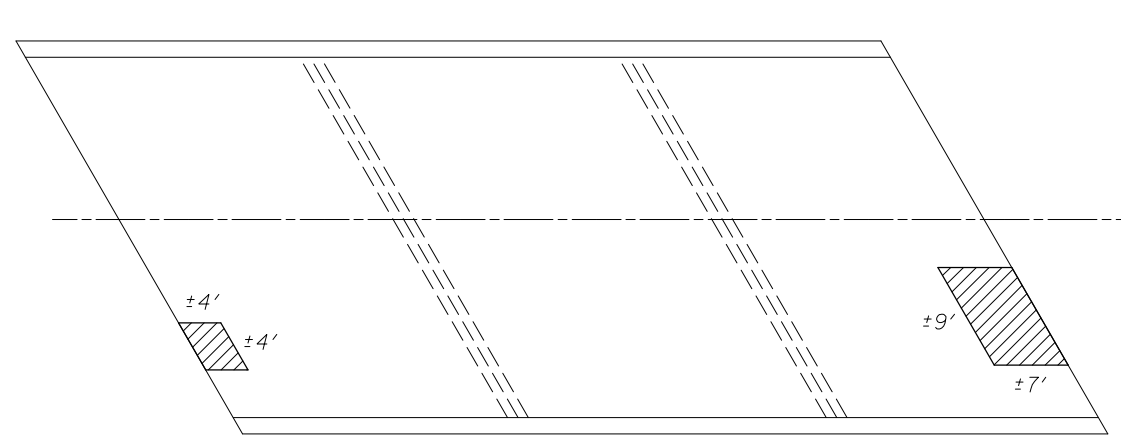

PLAN DECK REPAIR
S.N. 021-0006 N.B.

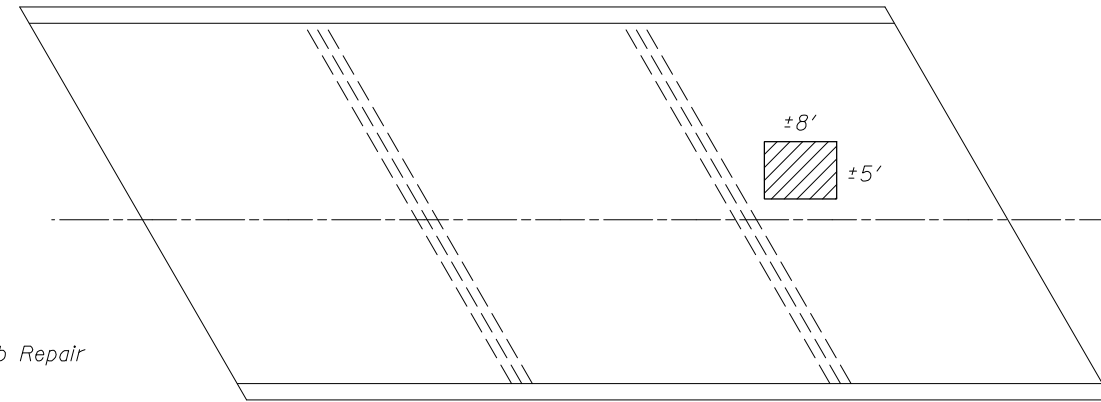

PLAN DECK REPAIR
S.N. 021-0005 S.B.

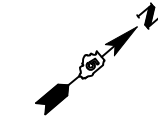

Deck Slab Repair (Partial)

Notes:
Areas of Partial Depth Patching are located as shown on the plan view of the deck. The exact size and locations of the patches shall be determined by the Engineer.

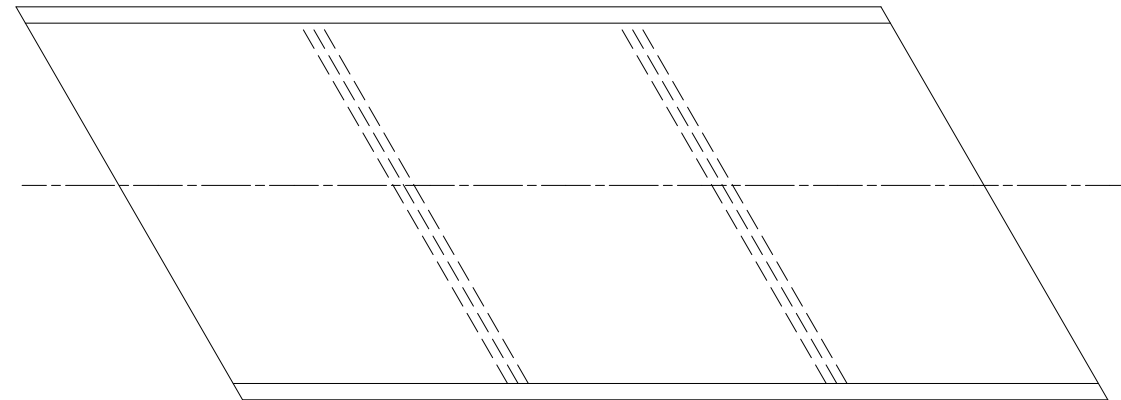

PLAN VIEW OF AS-BUILT PATCHES
S.N. 021-0006 N.B.

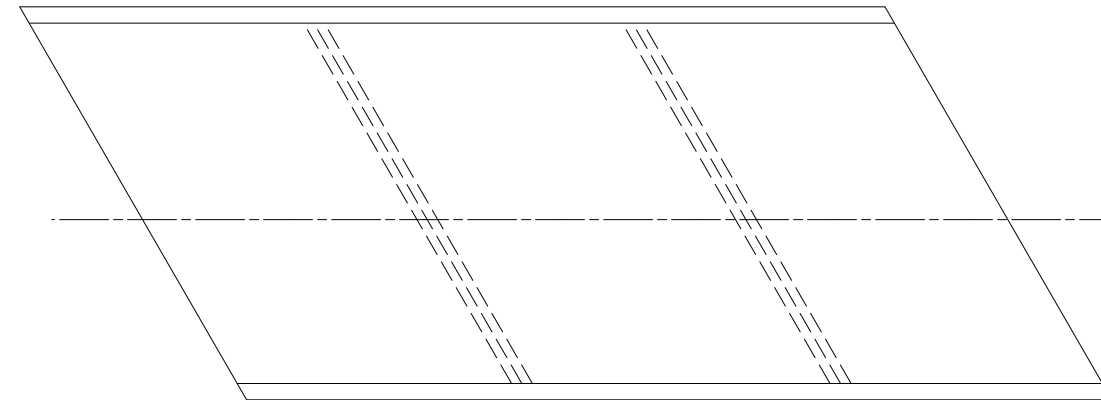

PLAN VIEW OF AS-BUILT PATCHES
S.N. 021-0005 S.B.

Partial Depth
 Full Depth

All actual areas of patching are to be shown on the as-built plan view and included in the as-built plans.

F.A.I. 57 OVER DRAINAGE DITCH
SECTION 21-27B-1
DOUGLAS COUNTY
S.N. 021-0006 N.B. &
S.N. 021-0005 S.B.

SHEET 3 OF 3

ILLINOIS DEPARTMENT OF TRANSPORTATION
DECK REPAIR
F.A.I. ROUTE 57
SECTION (15,21-25,21-26,27)RS-1
DOUGLAS COUNTY

SCALE: NOT TO SCALE
DATE: 03/12/08
DRAWN BY: J.P.
CHECKED BY: K.D.

PLOT DATE = 8/21/2008
 FILE NAME = c:\projects\view\4580385 (6)\78465b-rdgedetail.dgn
 PLOT SCALE = 1/8"=1'-0"
 USER NAME = sheehyjm

F.A.I. RTE.	SECTION	COUNTY	TOTAL SHEETS	SHEET NO.
57	*	DOUGLAS	76	55

* (15,21-25,21-26,27)RS-1

GENERAL PLAN AND ELEVATION

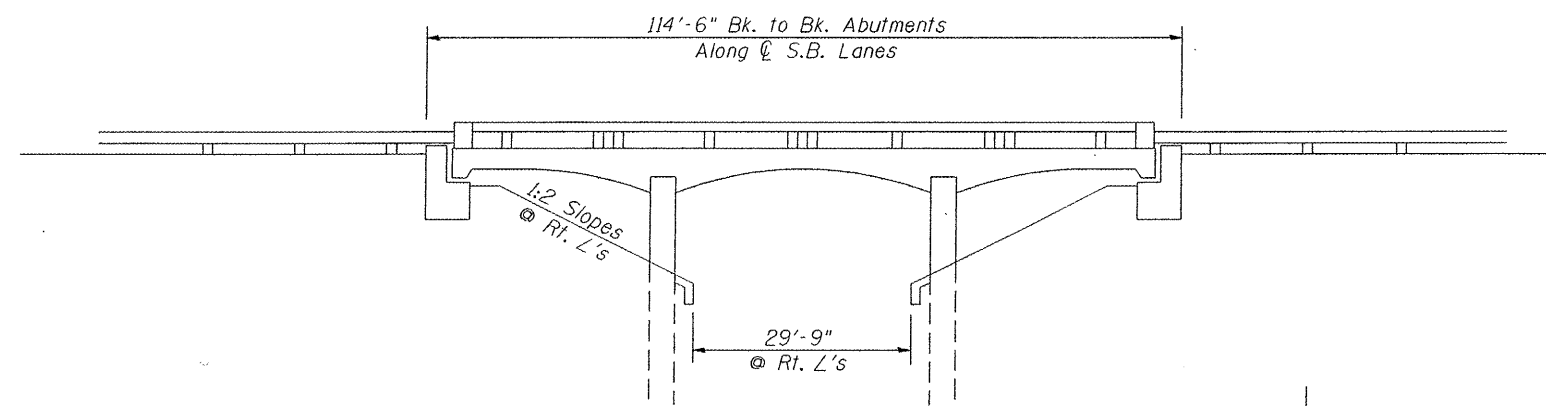

ELEVATION

Plan dimensions and details relative to existing plans are subject to routine variations. The Contractor shall field verify existing dimensions and details affecting new construction and make necessary approved adjustments prior to construction or ordering of materials. Such variations shall not be cause for additional compensation for a change in the scope of work, however, the Contractor will be paid for the quantity actually furnished based upon the unit price bid for the work.

ITEM	UNIT	QUANTITY
Stone Riprap, Class A4	Ton	265.0
Slopedwall Breaking	Sq Yd	177.0

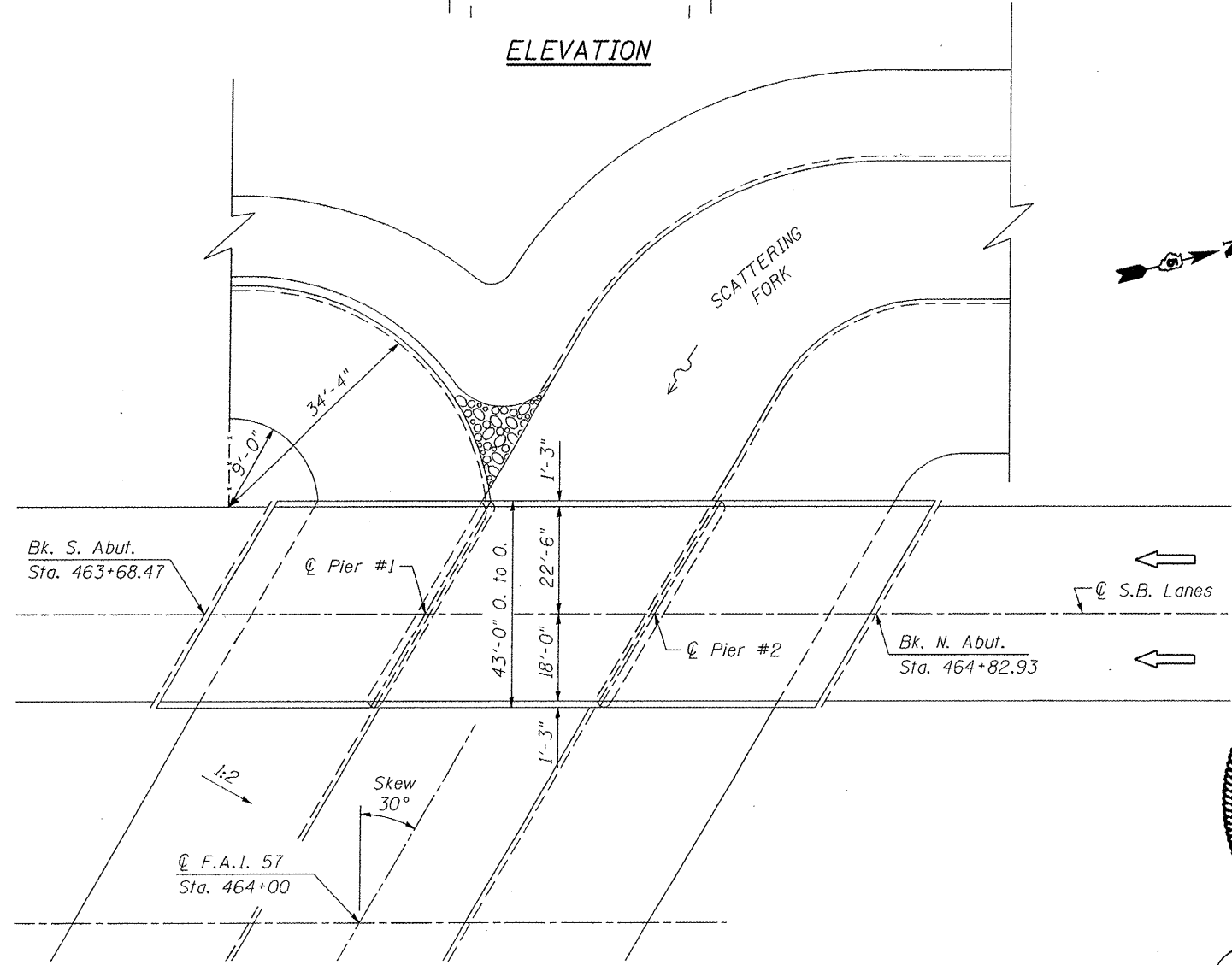

PLAN
S.N. 021-0008 S.B.

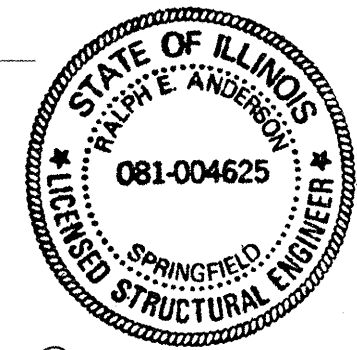

Ralph E. Anderson
Expires Nov. 30, 2008

F.A.I. 57 OVER SCATTERING FORK
SECTION 21-27B-2
DOUGLAS COUNTY
S.N. 021-0008 S.B.

SHEET 1 OF 2

ILLINOIS DEPARTMENT OF TRANSPORTATION
GENERAL PLAN AND ELEVATION
F.A.I. ROUTE 57
SECTION (15,21-25,21-26,27)RS-1
DOUGLAS COUNTY
SCALE: NOT TO SCALE
DATE: 03/12/08
DRAWN BY: J.P.
CHECKED BY: K.D.

PLOT DATE = 03/12/08
 PLOT SCALE = 1/8" = 1'-0"
 USER NAME = ahahyom

F.A.I. RTE.	SECTION	COUNTY	TOTAL SHEETS	SHEET NO.
57	*	DOUGLAS	76	56

*(15,21-25,21-26,27)RS-1

SLOPE WALL REPAIR

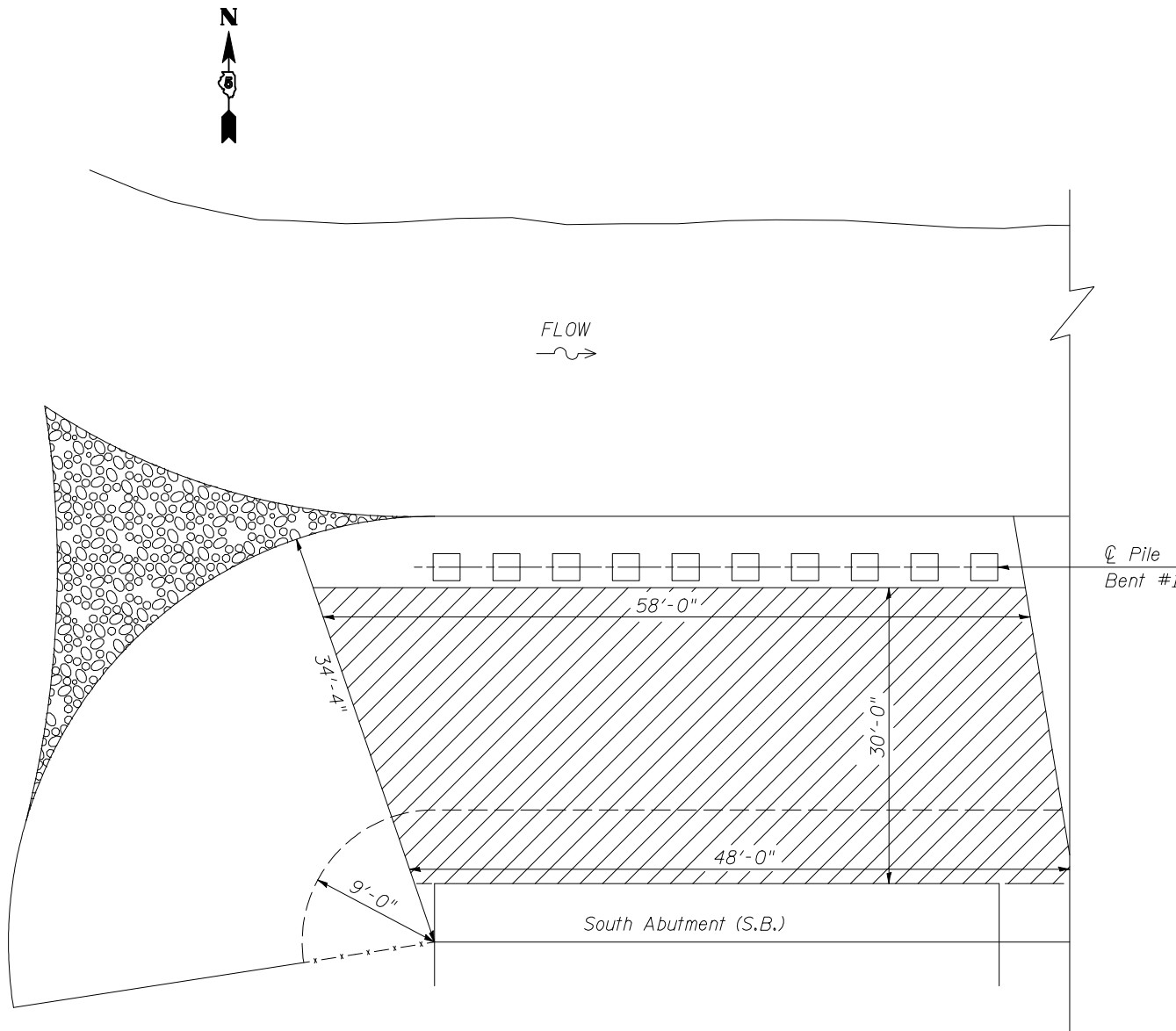

SLOPE WALL REPAIR LOCATION
S.N. 021-0008 SOUTH ABUTMENT

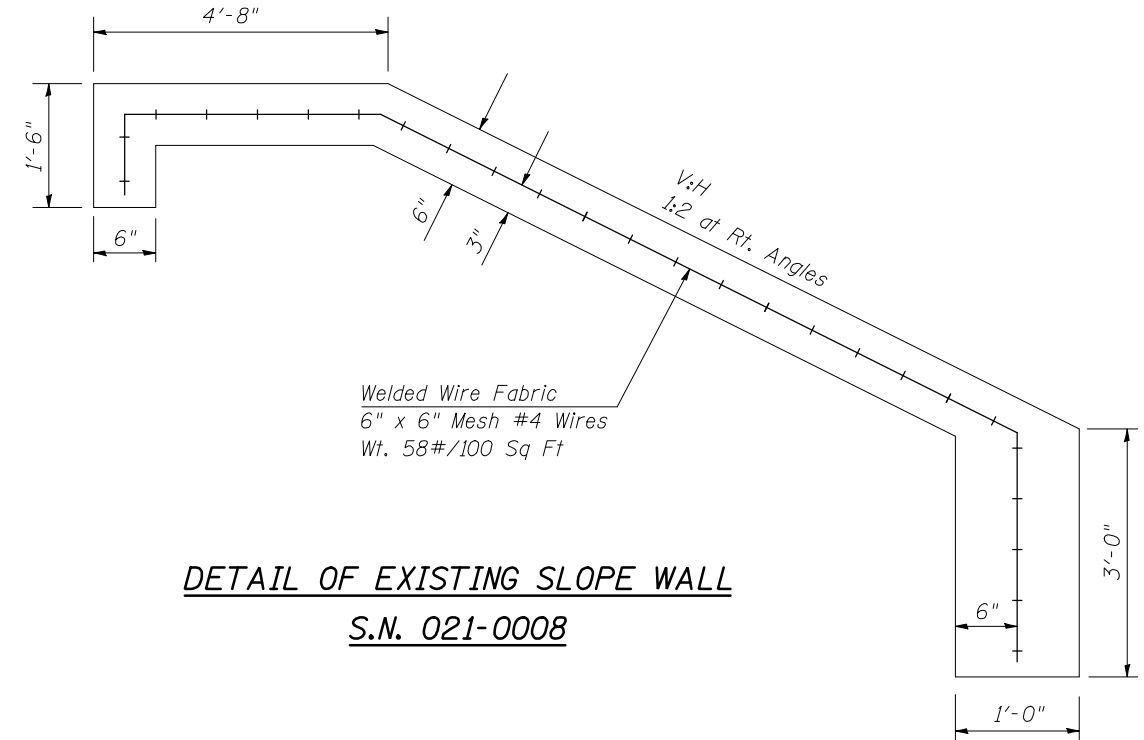

DETAIL OF EXISTING SLOPE WALL
S.N. 021-0008

 Area of Slope Wall Breaking and Placement of Stone Riprap, Class A4

F.A.I. 57 OVER SCATTERING FORK
SECTION 21-27B-2
DOUGLAS COUNTY
S.N. 021-0008 S.B.

SHEET 2 OF 2

ILLINOIS DEPARTMENT OF TRANSPORTATION

SLOPE WALL REPAIR

F.A.I. ROUTE 57
SECTION (15,21-25,21-26,27)RS-1
DOUGLAS COUNTY

SCALE: NOT TO SCALE
DATE: 03/12/08

DRAWN BY: J.P.
CHECKED BY: K.D.

F.A.I. RTE.	SECTION	COUNTY	TOTAL SHEETS	SHEET NO.
57	*	DOUGLAS	76	57

* (15,21-25,21-26,27)RS-1

I-57 (SB) / IL ROUTE 133 INTERCHANGE
 SB I-57 'ON' RAMP D & SB I-57 'OFF' RAMP A @ IL ROUTE 133

I-57 (NB) / IL ROUTE 133 INTERCHANGE
 NB I-57 'ON' RAMP B & NB I-57 'OFF' RAMP C @ IL ROUTE 133

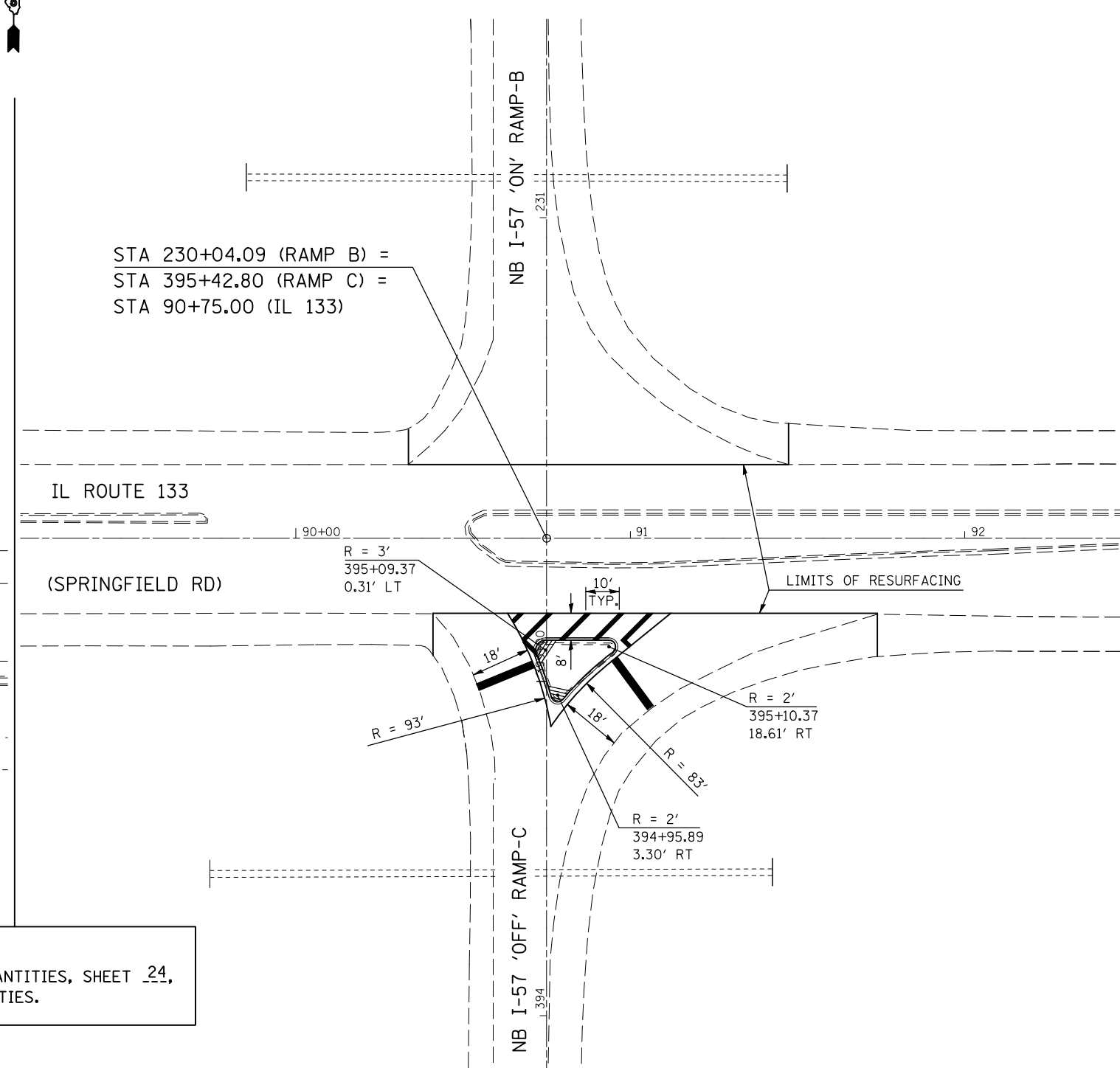
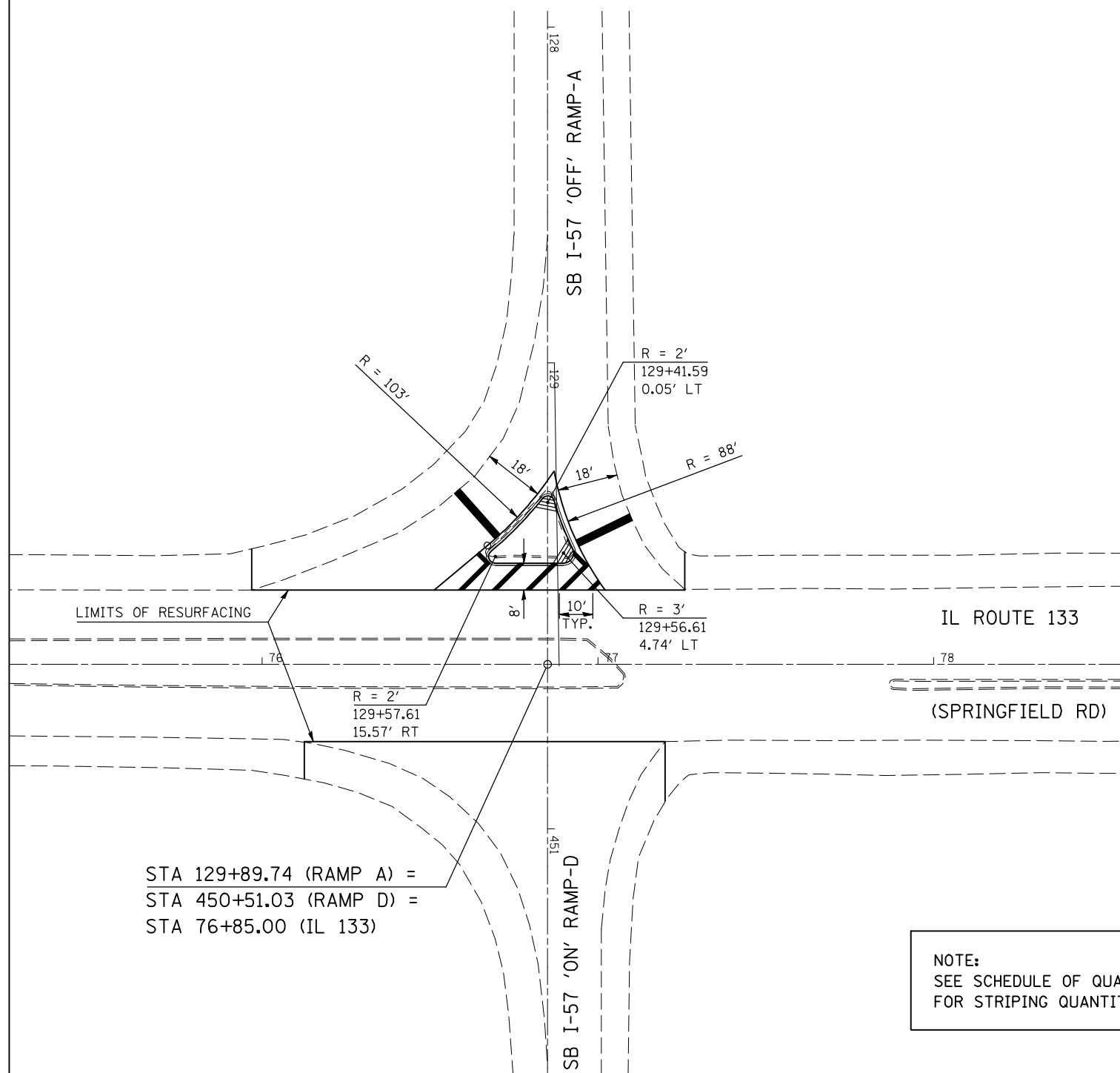

NOTE:
 SEE SCHEDULE OF QUANTITIES, SHEET 24,
 FOR STRIPING QUANTITIES.

44002805 ISLAND REMOVAL

LOCATION	SQ FT
RAMP A	292.8
RAMP C	247.1
TOTAL	= 539.9

35300505 PORTLAND CEMENT CONCRETE BASE COURSE, 10 1/4"

LOCATION	SQ YD
RAMP A	32.5
RAMP C	27.5
TOTAL	= 60.0

60622354 CONCRETE MEDIAN, TYPE SM-6 (DOWELED)

LOCATION	SQ FT
RAMP A	345.1
RAMP C	309.0
TOTAL	= 654.1

AT ARCOLA

ILLINOIS DEPARTMENT OF TRANSPORTATION
I-57 / IL 133
INTERCHANGE DETAILS
 F.A.I. ROUTE 57
 SECTION (15,21-25,21-26,27)RS-1
 DOUGLAS COUNTY

SCALE: 1"=20'
 DATE: 07-2008
 DRAWN BY: JRP
 CHECKED BY: KBD

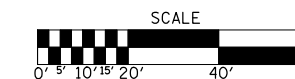

PLOT DATE = 8/21/2008
 FILE NAME = c:\projects\5801385 (v8)\78465detaila.dgn
 PLOT SCALE = 4.23625' / IN.
 USER NAME = sheehyjm

F.A.I. RTE.	SECTION	COUNTY	TOTAL SHEETS	SHEET NO.
57	*	DOUGLAS	76	58

* (15,21-25,21-26,27)RS-1

I-57 (SB) / US ROUTE 36 INTERCHANGE
 SB I-57 'ON' RAMP A & SB I-57 'OFF' RAMP B @ US ROUTE 36

I-57 (NB) / US ROUTE 36 INTERCHANGE
 NB I-57 'OFF' RAMP C & NB I-57 'ON' RAMP D @ US ROUTE 36

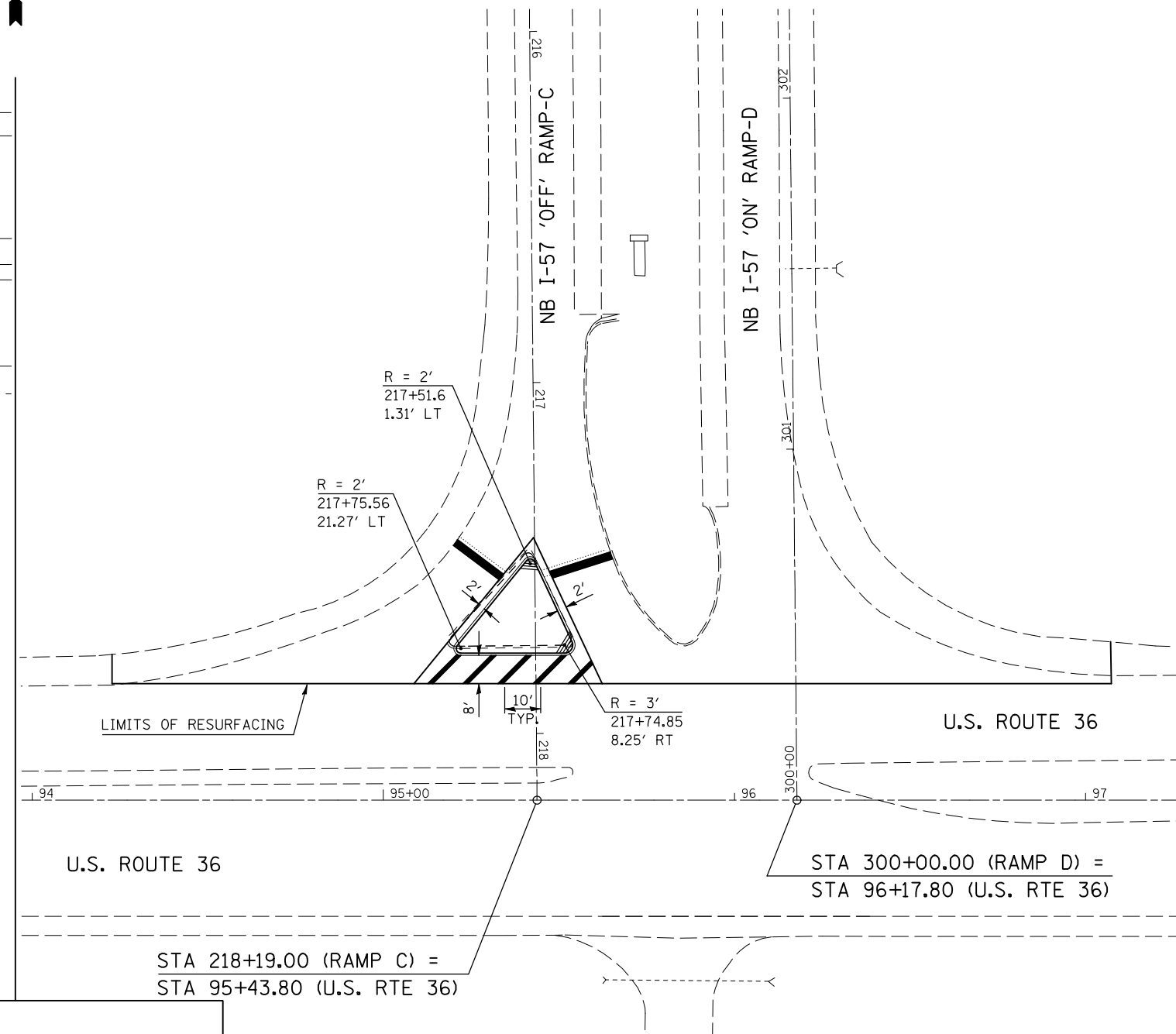
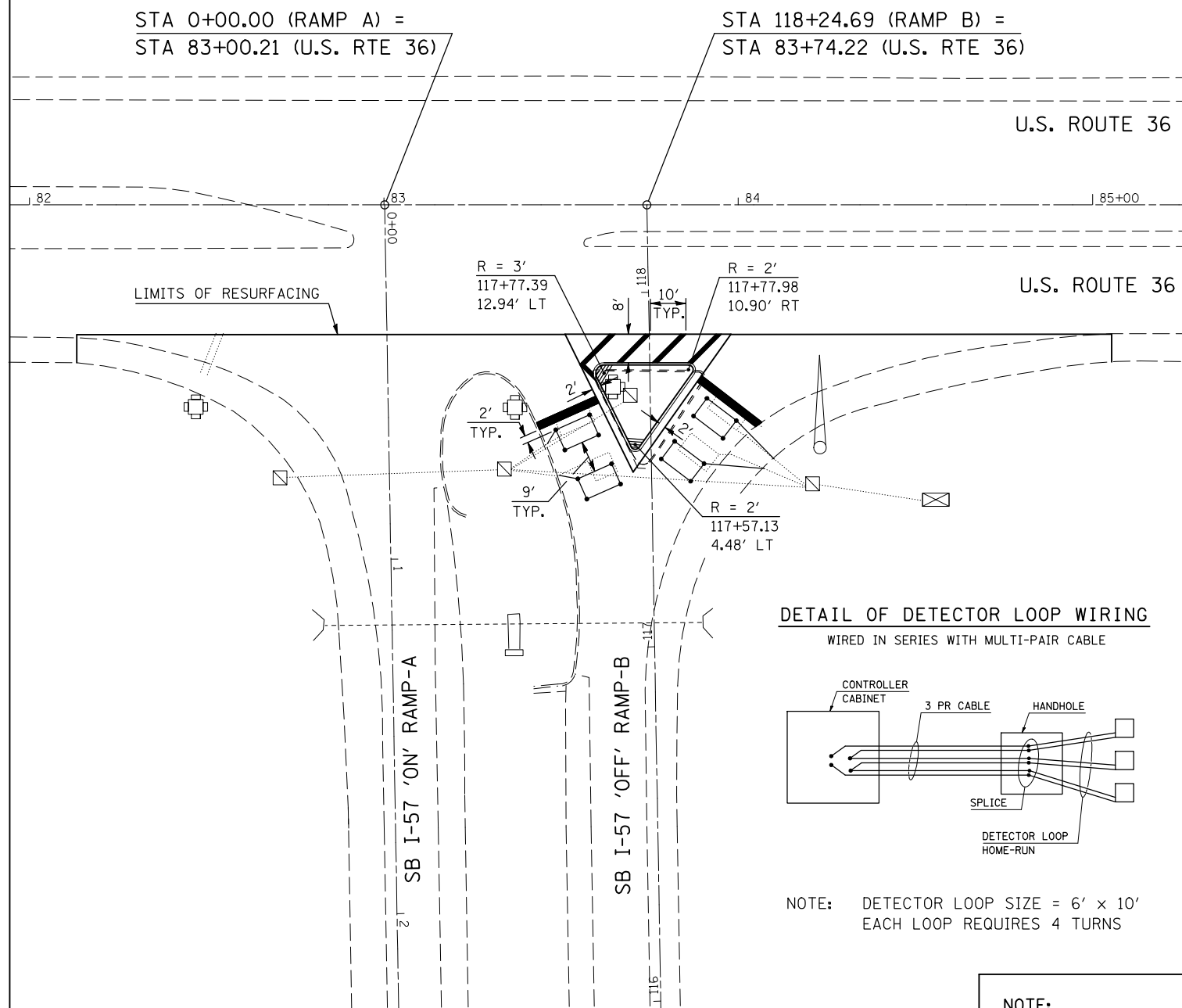

NOTE:
 SEE SCHEDULE OF QUANTITIES, SHEET 24,
 FOR STRIPING QUANTITIES.

44002805 ISLAND REMOVAL

LOCATION	SQ FT
RAMP B	505.4
RAMP C	566.3

TOTAL = 1071.7

35300505 PORTLAND CEMENT CONCRETE BASE COURSE, 10 1/4"

LOCATION	SQ YD
RAMP B	56.2
RAMP C	62.9

TOTAL = 119.1

60622354 CONCRETE MEDIAN, TYPE SM-6 (DOWELED)

LOCATION	SQ FT
RAMP B	427.9
RAMP C	563.1

TOTAL = 991.0

81400115 HANDHOLE TO BE ADJUSTED

LOCATION	EACH
RAMP B ISLAND	1.0

TOTAL = 1.0

AT TUSCOLA

ILLINOIS DEPARTMENT OF TRANSPORTATION
I-57 / US 36
INTERCHANGE DETAILS
 F.A.I. ROUTE 57
 SECTION (15,21-25,21-26,27)RS-1
 DOUGLAS COUNTY

SCALE: 1"=20'
 DATE: 07-2008
 DRAWN BY: JRP
 CHECKED BY: KBD



PLOT DATE = 8/21/2008
 FILE NAME = c:\p\projects\45801385 (v8)\78465detaila.dgn
 PLOT SCALE = 42,3525 / IN.
 USER NAME = sheehyjm

F.A.I. RTE.	SECTION	COUNTY	TOTAL SHEETS	SHEET NO.
57	*	DOUGLAS	76	59

* (15,21-25,21-26,27)RS-1

DETAIL OF BUTT JOINT - DRIVING LANE

AT START OF PROJECT: STA 1387+81 (NB & SB)
& UNDER S.N. 021-0041 (NB & SB)

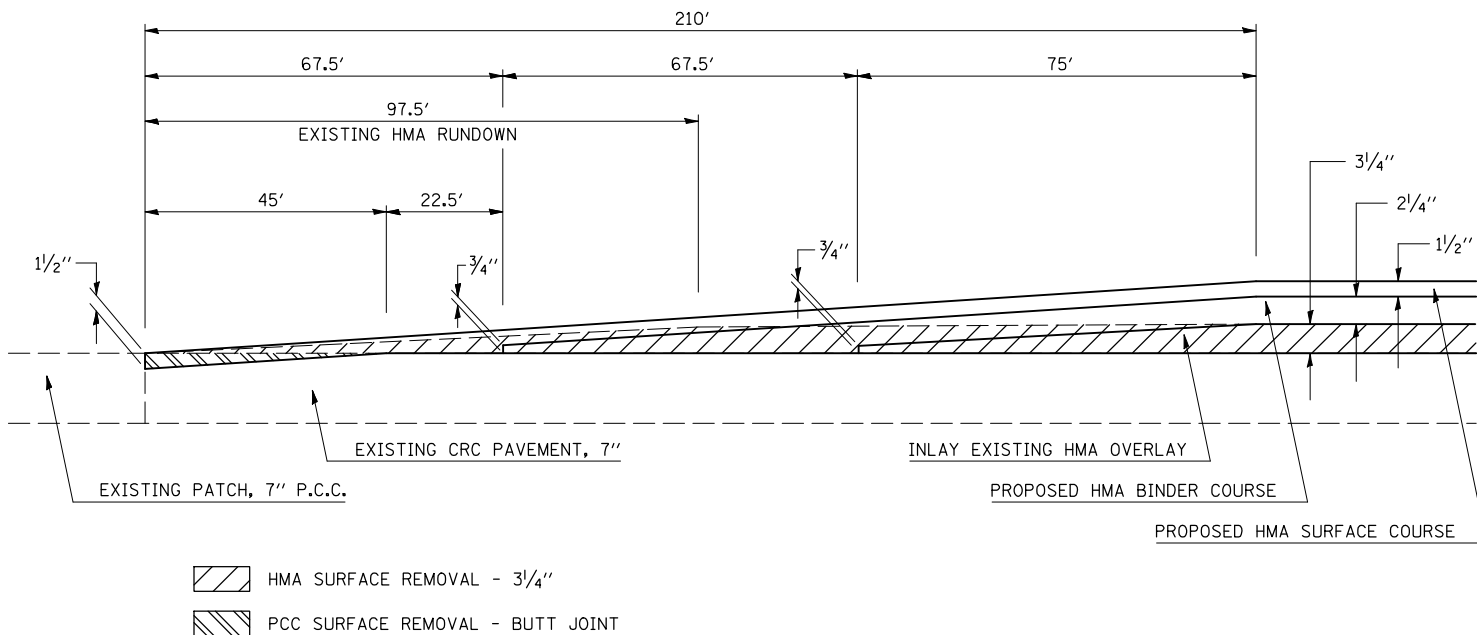

DETAIL OF BUTT JOINT - DRIVING LANE

UNDER S.N. 021-0024 (NB ONLY)

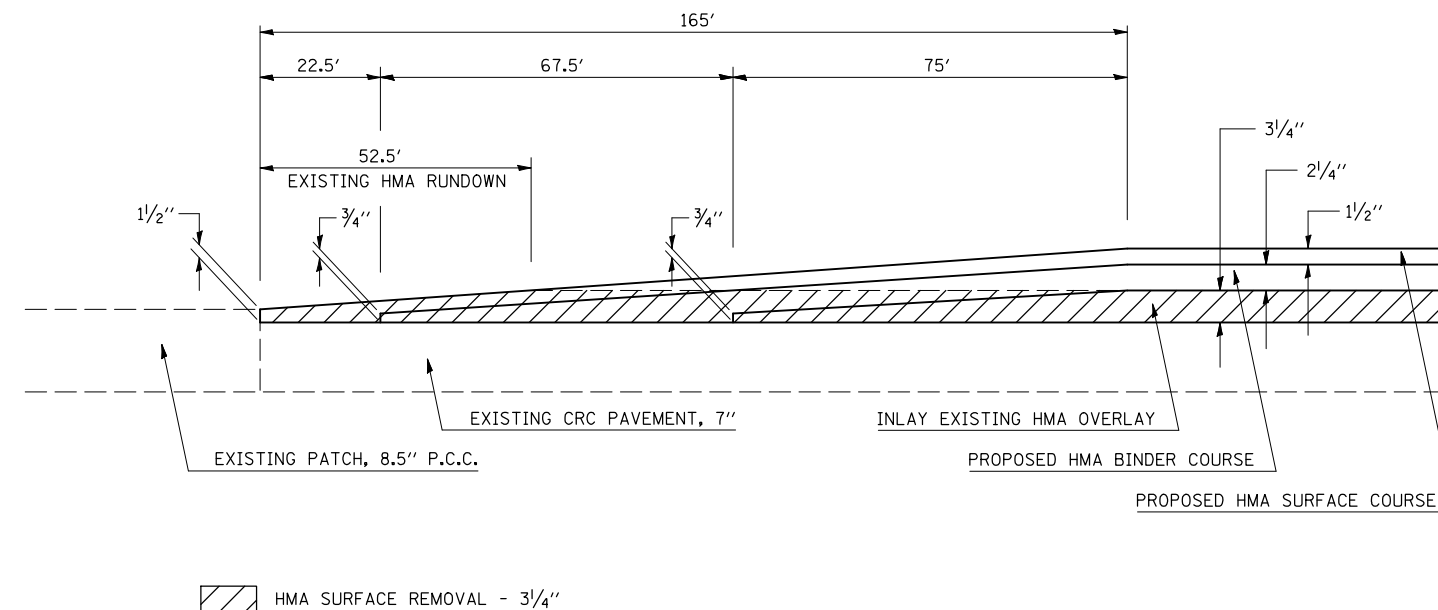

DETAIL OF BUTT JOINT - PASSING LANE

AT START OF PROJECT: STA 1387+81 (NB & SB)
& UNDER S.N. 021-0041 (NB & SB)

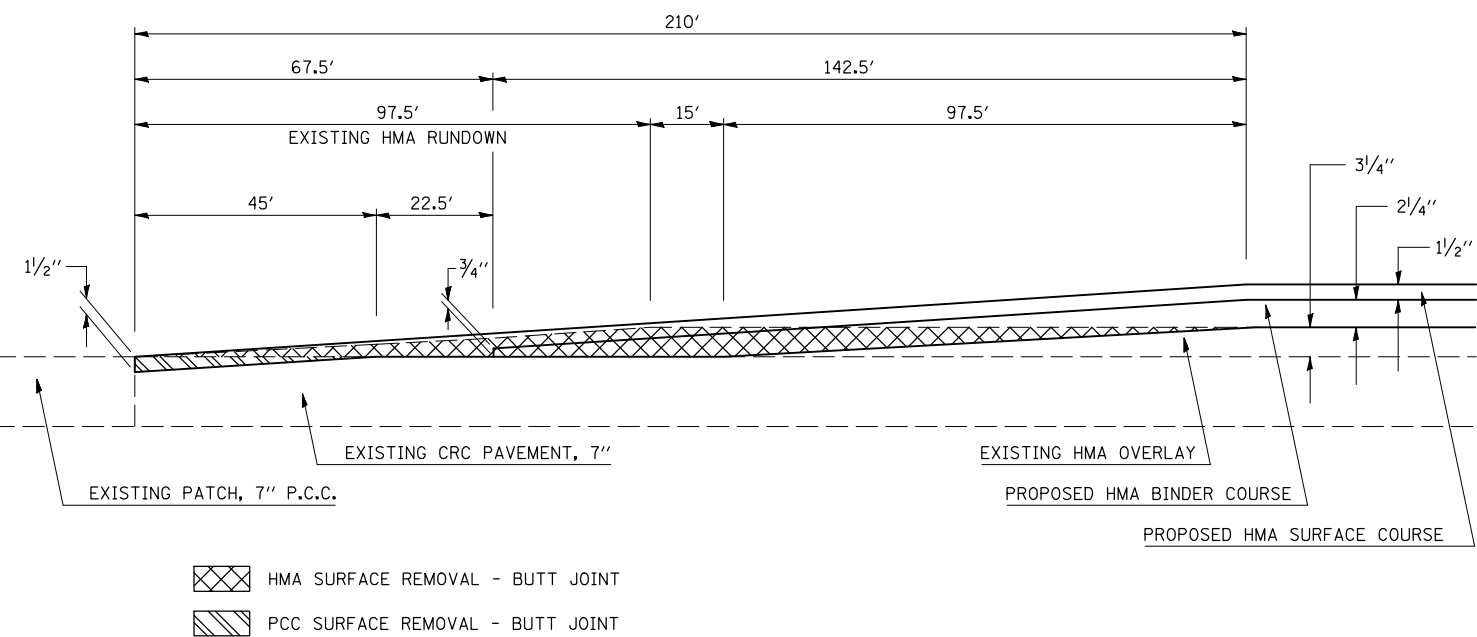

DETAIL OF BUTT JOINT - PASSING LANE

UNDER S.N. 021-0024 (NB ONLY)

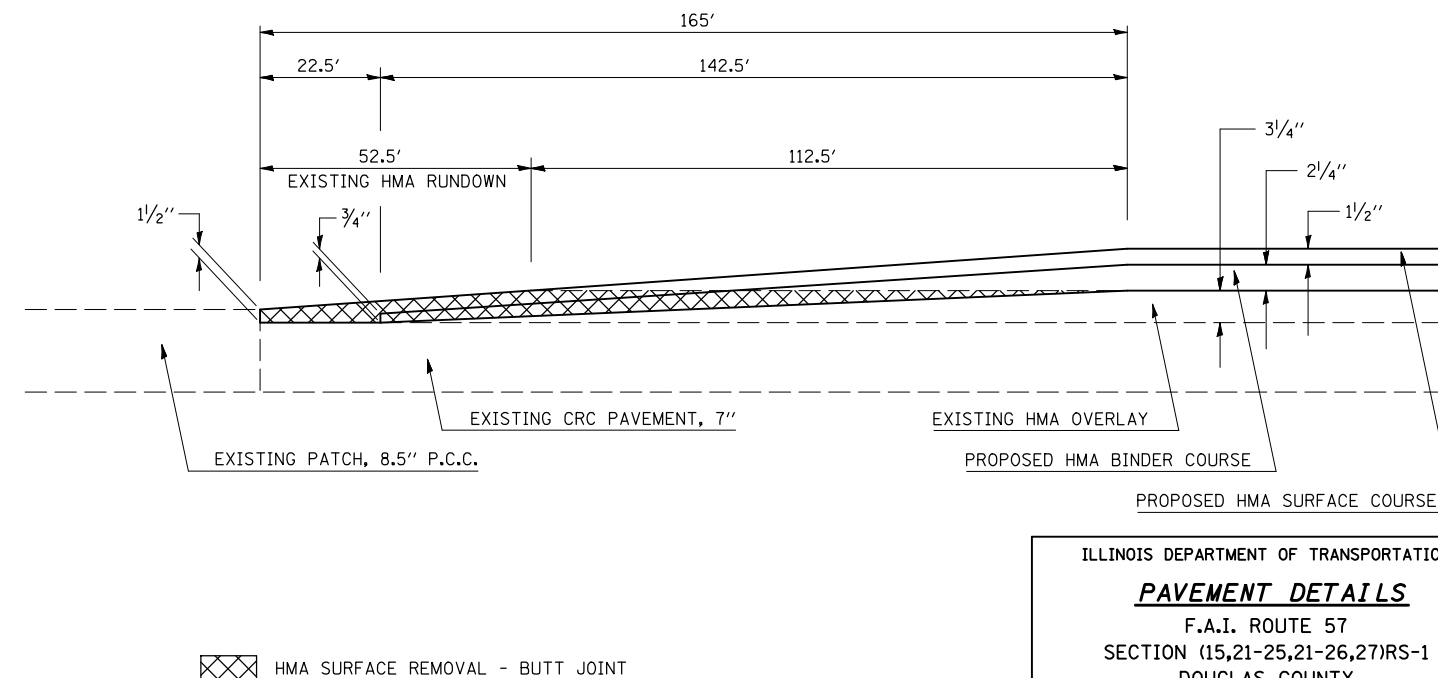

PLOT DATE = 8/21/2008
FILE NAME = c:\p\projects\0501385 (v8)\70465\detail.dgn
PLOT SCALE = 1/8"=1'-0"
USER NAME = sheehyjm

ILLINOIS DEPARTMENT OF TRANSPORTATION
PAVEMENT DETAILS
F.A.I. ROUTE 57
SECTION (15,21-25,21-26,27)RS-1
DOUGLAS COUNTY
SCALE: N/A
DATE: 07-2008
DRAWN BY: JRP
CHECKED BY: KBD

F.A.I. RTE.	SECTION	COUNTY	TOTAL SHEETS	SHEET NO.
57	*	DOUGLAS	76	60

* (15,21-25,21-26,27)RS-1

DETAIL OF INLAY UNDER OVERHEAD STRUCTURES

S. N. 021-0024 (SB ONLY)
& S. N. 021-0045 (NB ONLY)

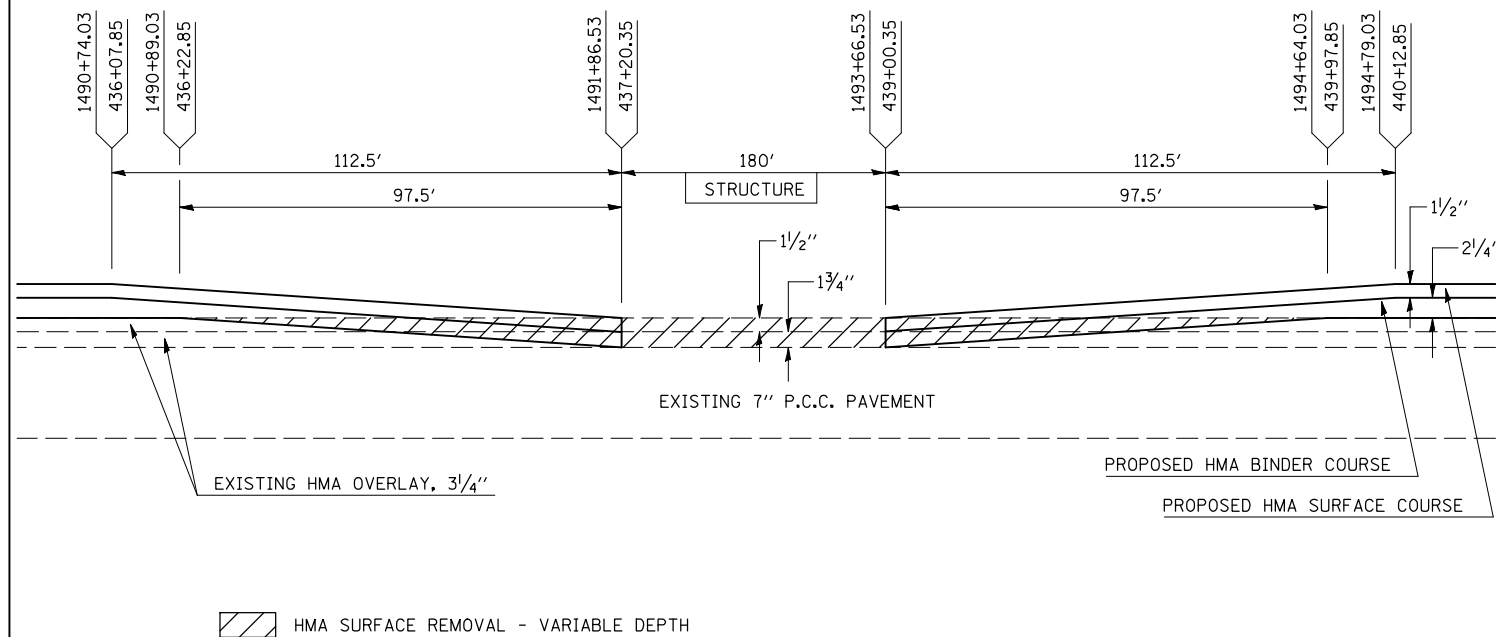

DETAIL OF HMA TRANSITION

- ① STA 175+13.87 (NB & SB)
- ② STA 310+00 (NB ONLY)
- ③ STA 330+00 (NB ONLY)
- ④ STA 390+00 (NB ONLY)

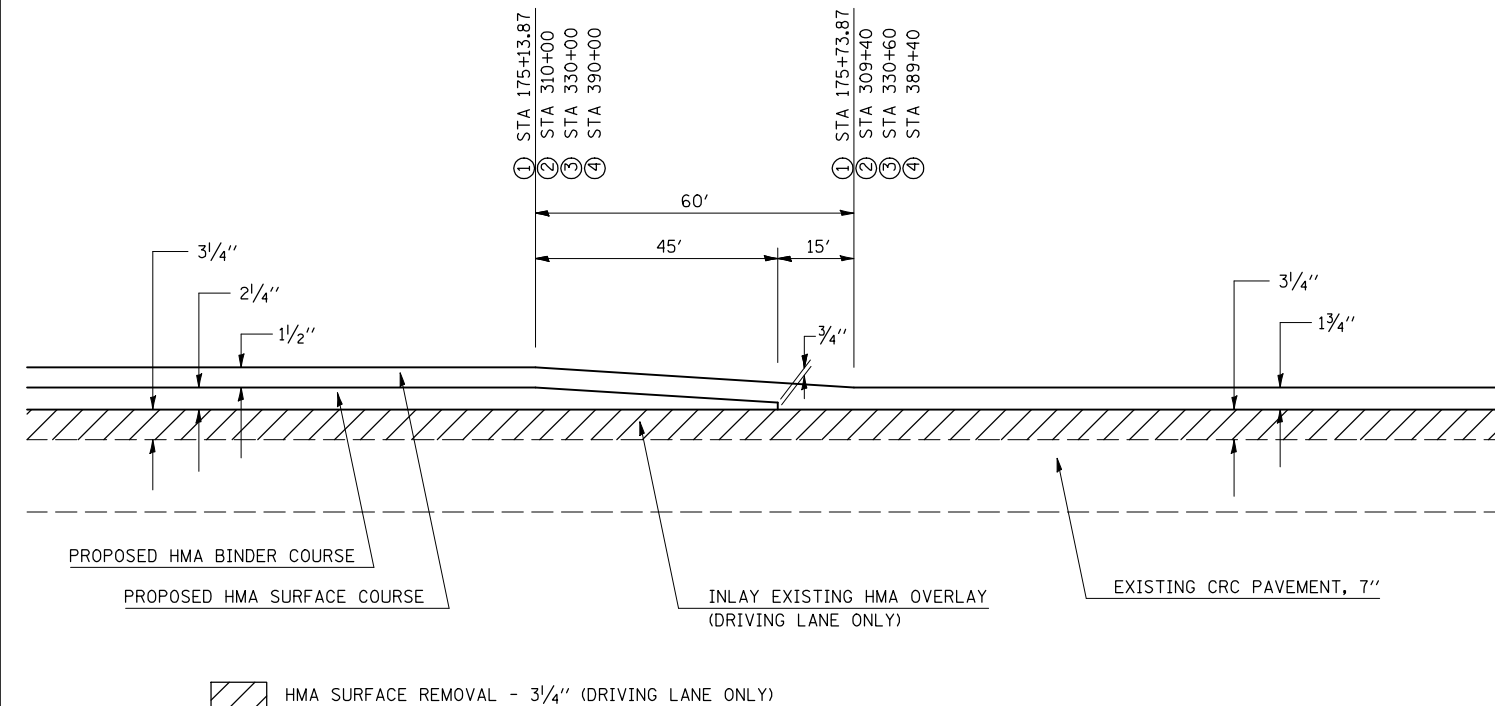

BUTT JOINT DETAIL AT EXISTING STRUCTURES

S. N. 021-001 & S. N. 021-0002

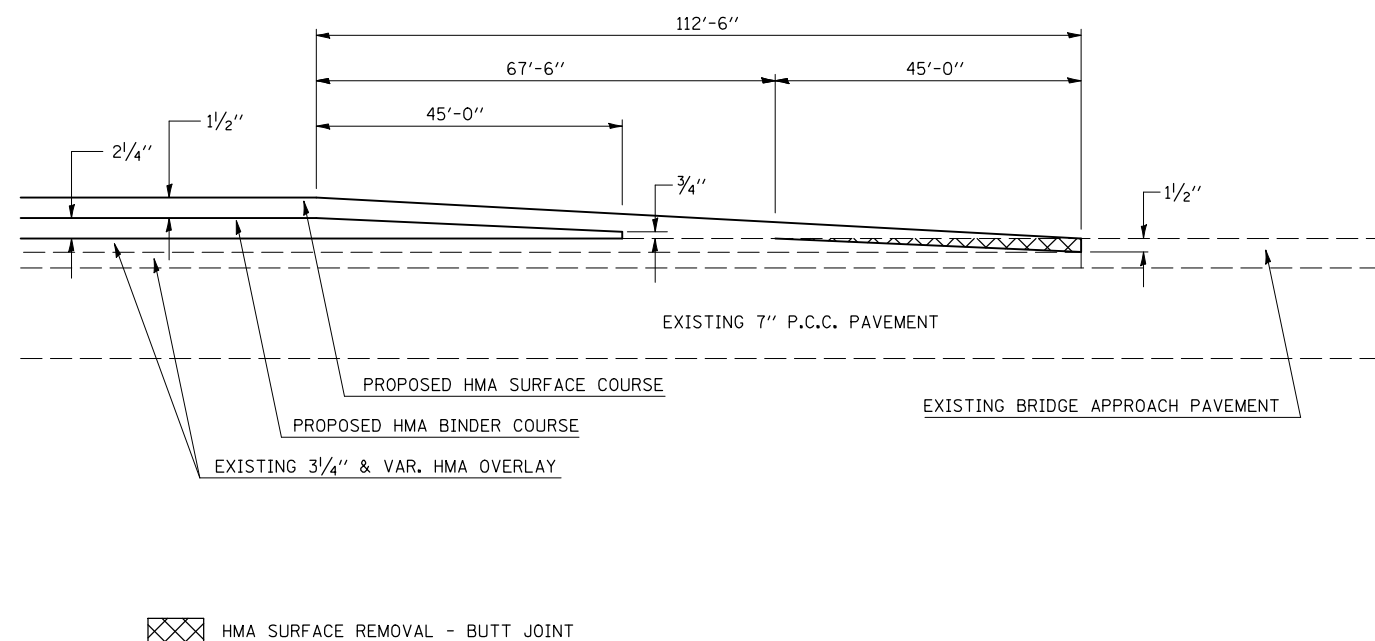

ILLINOIS DEPARTMENT OF TRANSPORTATION

PAVEMENT DETAILS

F.A.I. ROUTE 57
SECTION (15,21-25,21-26,27)RS-1
DOUGLAS COUNTY

SCALE: N/A
DATE: 07-2008

DRAWN BY: JRP
CHECKED BY: KBD

F.A.I. RTE.	SECTION	COUNTY	TOTAL SHEETS	SHEET NO.
57	*	DOUGLAS	76	61

*(15,21-25,21-26,27)RS-1

DETAIL OF BUTT JOINT - DRIVING LANE

S. N. 021-0003
 S. N. 021-0006
 S. N. 021-0007 (SOUTH APPROACH ONLY)

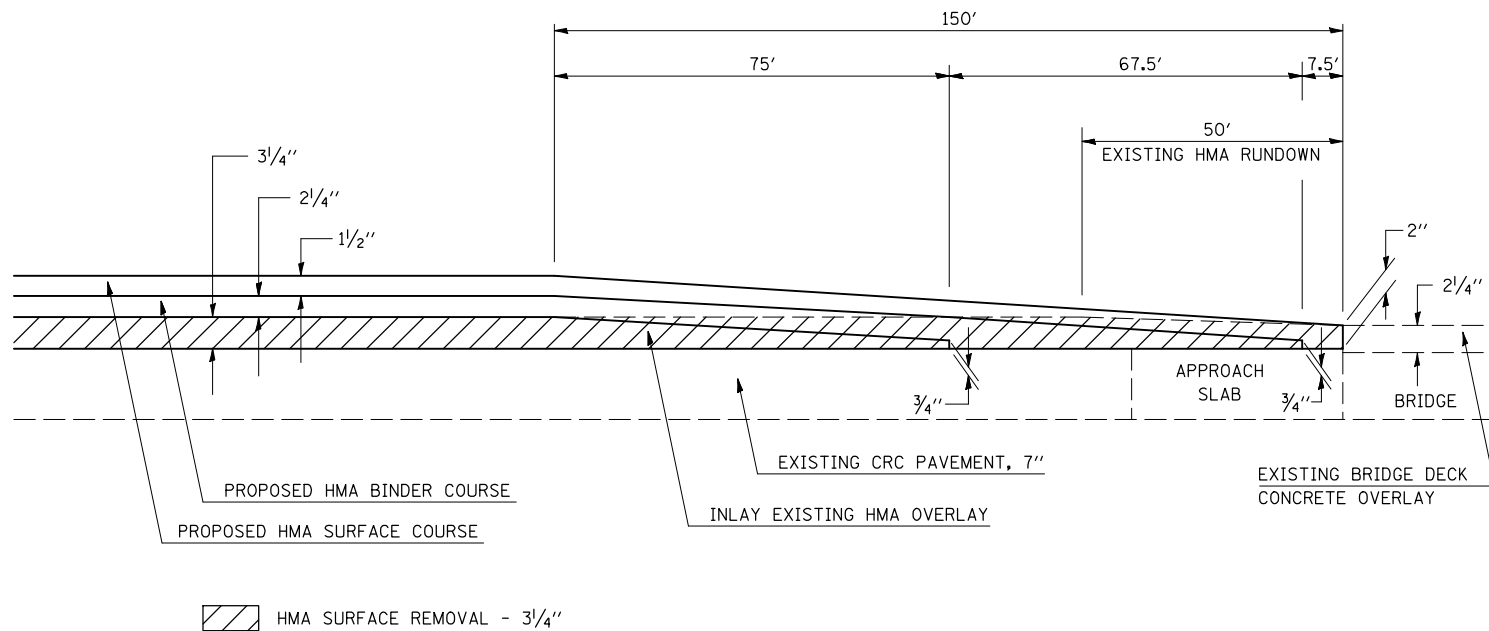

DETAIL OF BUTT JOINT - DRIVING LANE

S. N. 021-0004
 S. N. 021-0005
 S. N. 021-0008 (SOUTH APPROACH ONLY)

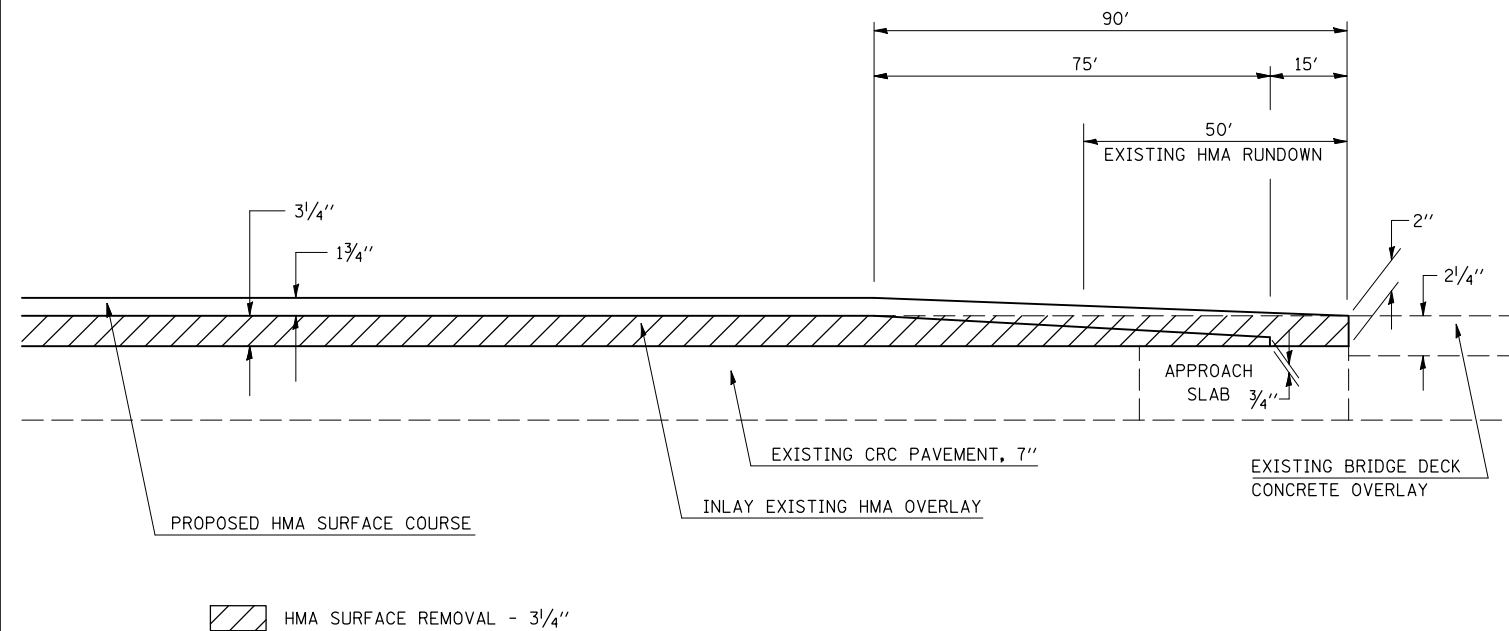

DETAIL OF BUTT JOINT - PASSING LANE

S. N. 021-0003
 S. N. 021-0006
 S. N. 021-0007 (SOUTH APPROACH ONLY)

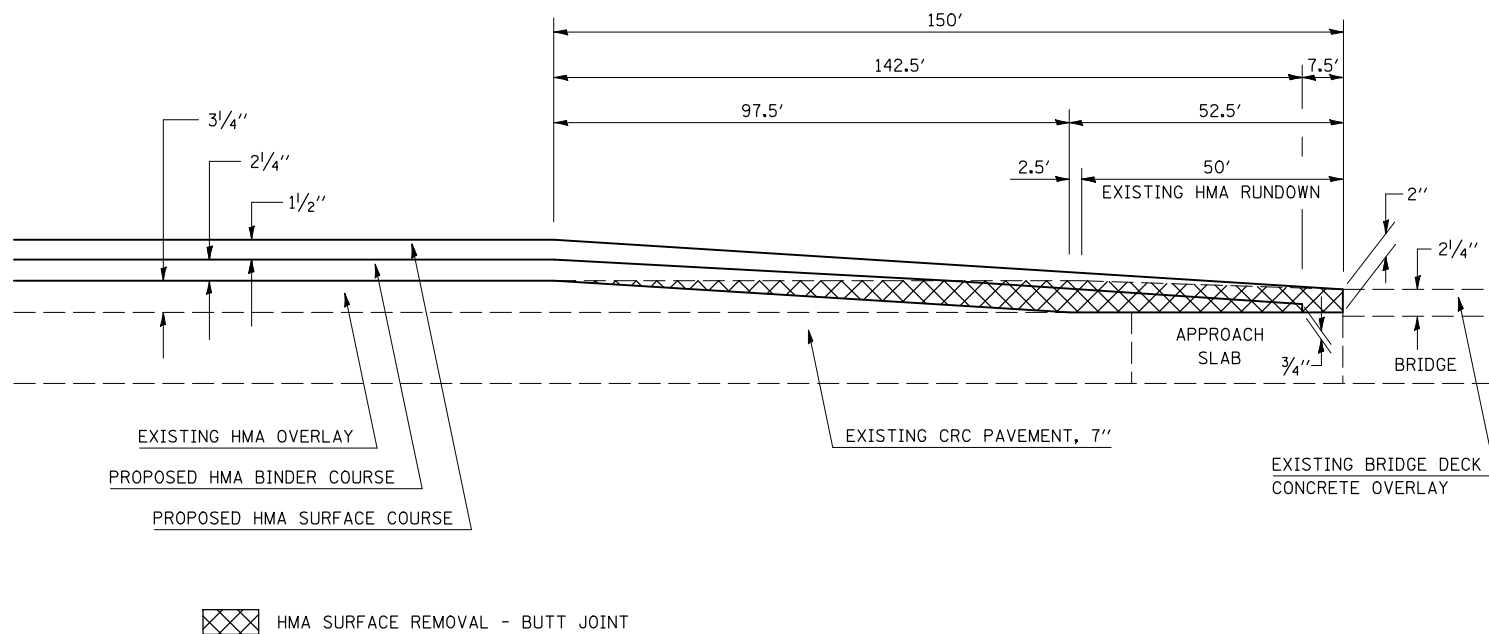

DETAIL OF BUTT JOINT - PASSING LANE

S. N. 021-0004
 S. N. 021-0005
 S. N. 021-0008 (SOUTH APPROACH ONLY)

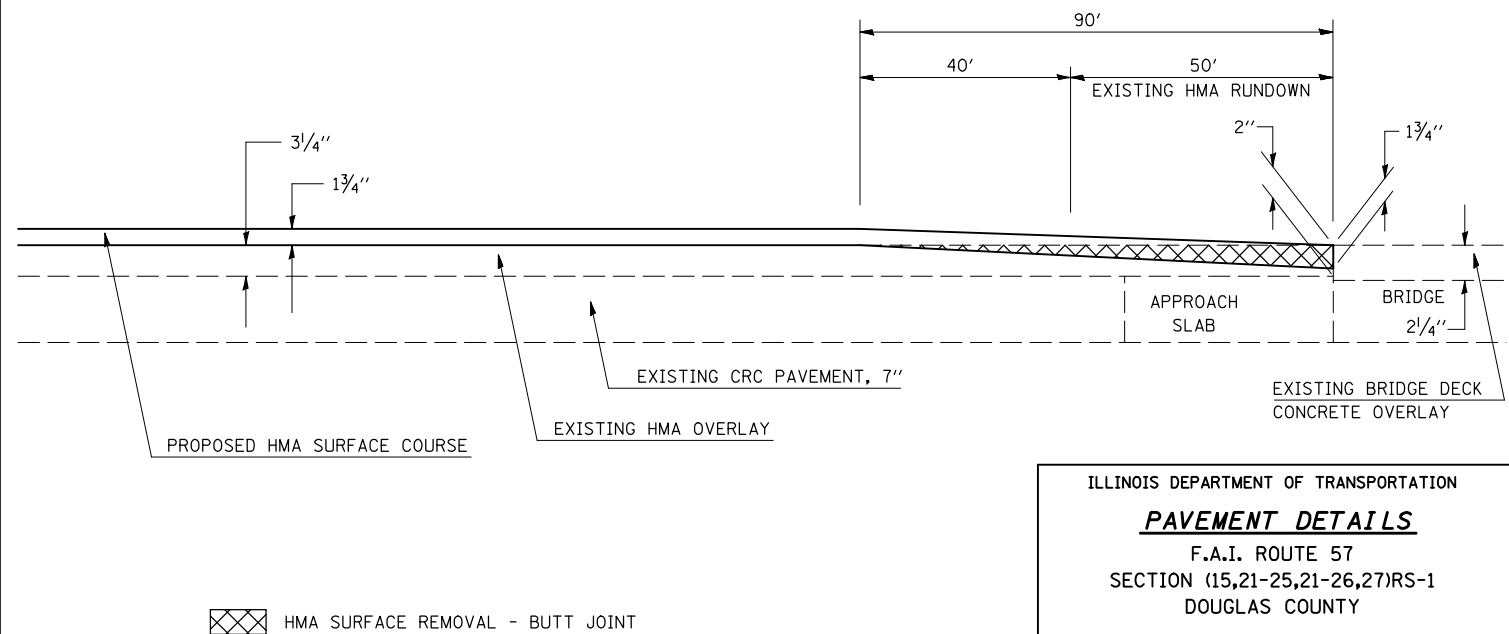

PLOT DATE = 8/21/2008
 FILE NAME = c:\projects\70465\detail.dgn
 PLOT SCALE = 1/8"=1'-0"
 USER NAME = sheehyjm

ILLINOIS DEPARTMENT OF TRANSPORTATION
PAVEMENT DETAILS
 F.A.I. ROUTE 57
 SECTION (15,21-25,21-26,27)RS-1
 DOUGLAS COUNTY

SCALE: N/A
 DATE: 07-2008
 DRAWN BY: JRP
 CHECKED BY: KBD

F.A.I. RTE.	SECTION	COUNTY	TOTAL SHEETS	SHEET NO.
57	*	DOUGLAS	76	63

* (15,21-25,21-26,27)RS-1

DETAIL OF HMA TRANSITION

STA 523+70 TO STA 524+70

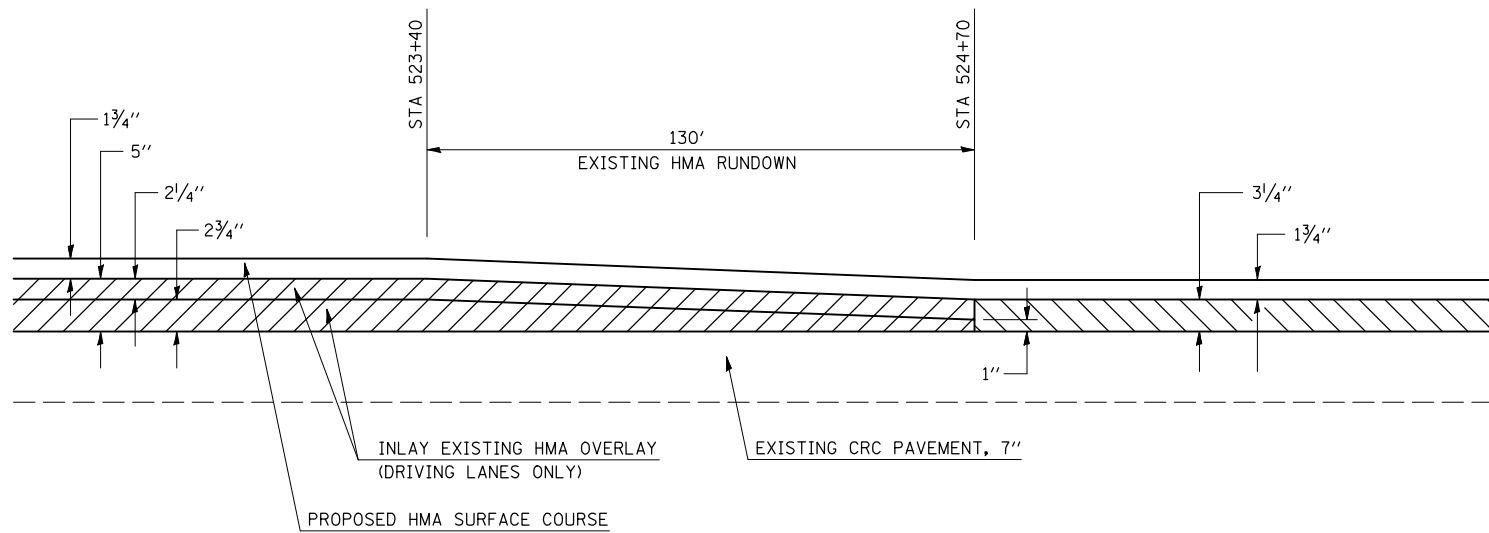

- HMA SURFACE REMOVAL - 5" (DRIVING LANES ONLY)
- HMA SURFACE REMOVAL - 3/4" (DRIVING LANES ONLY)

DETAIL OF BUTT JOINT - DRIVING LANE

END OF PROJECT (NB & SB)

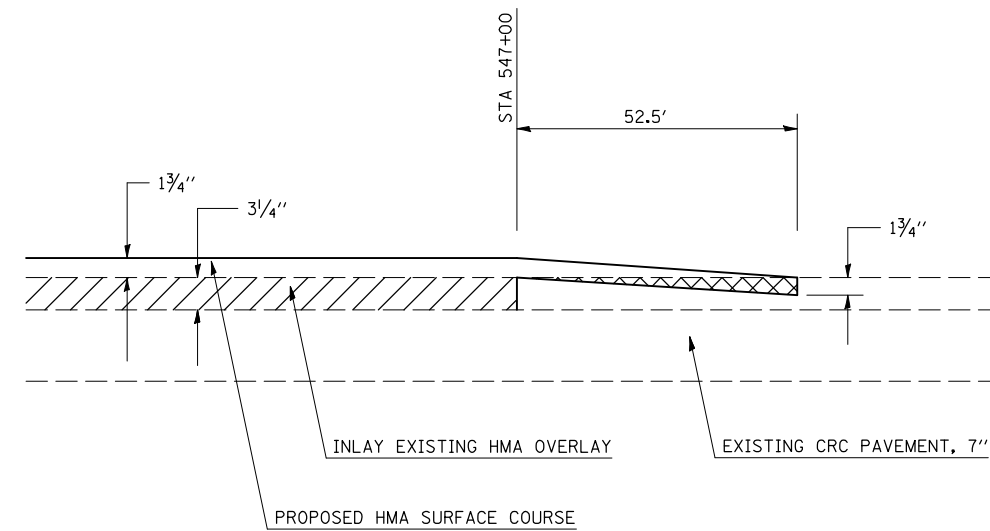

- HMA SURFACE REMOVAL - 3/4"
- HMA SURFACE REMOVAL - BUTT JOINT

DETAIL OF BUTT JOINT AT STRUCTURES

021-0009 & 021-0010

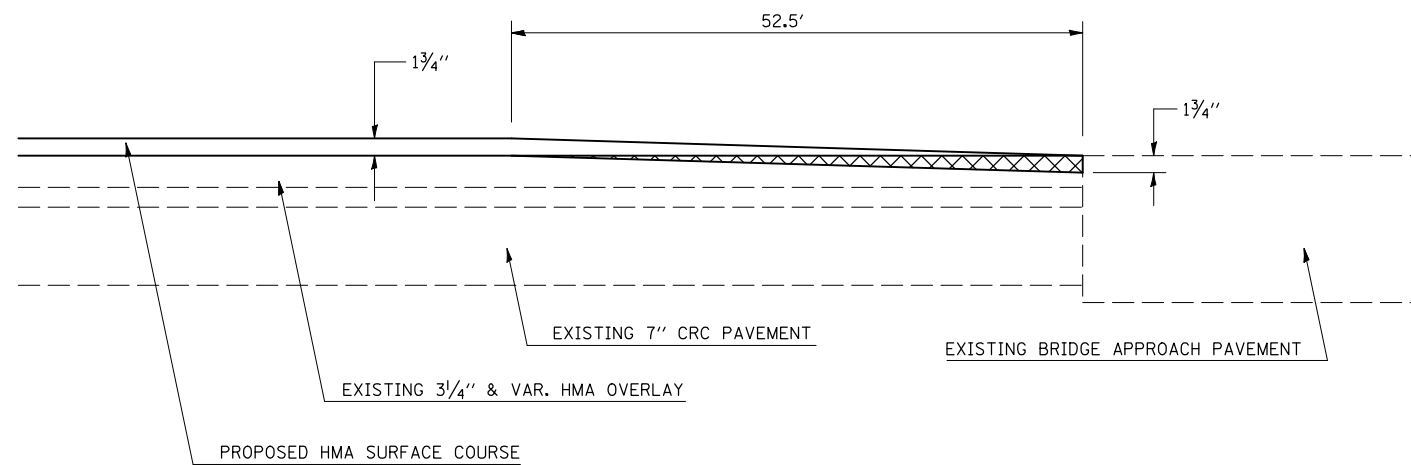

- HMA SURFACE REMOVAL - BUTT JOINT

DETAIL OF BUTT JOINT - PASSING LANE

END OF PROJECT (NB & SB)

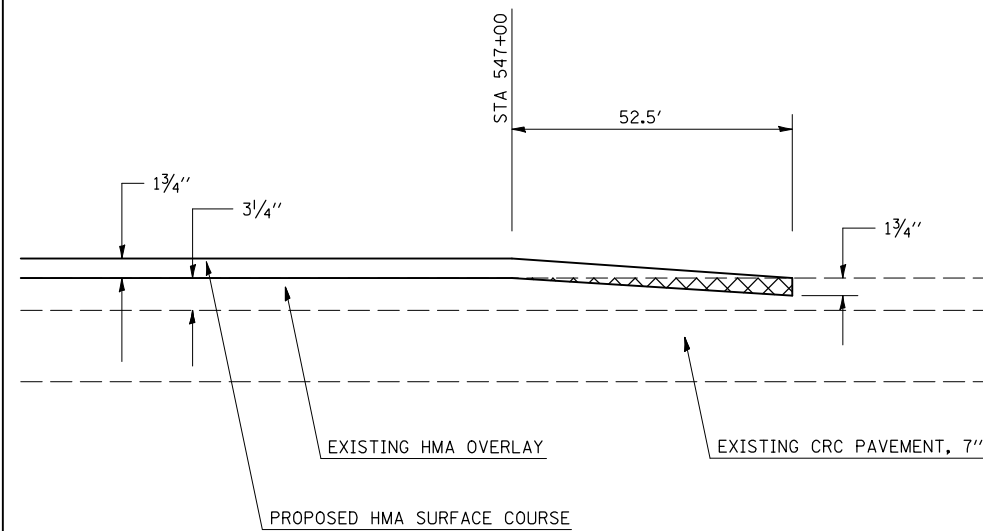

- HMA SURFACE REMOVAL - BUTT JOINT

ILLINOIS DEPARTMENT OF TRANSPORTATION
PAVEMENT DETAILS
 F.A.I. ROUTE 57
 SECTION (15,21-25,21-26,27)RS-1
 DOUGLAS COUNTY

SCALE: N/A
 DATE: 07-2008

DRAWN BY: JRP
 CHECKED BY: KBD

PLOT DATE = 8/21/2008
 FILE NAME = c:\projects\5801385 (v8)\70465details.dgn
 PLOT SCALE = 1/8"=1'-0"
 USER NAME = sheehyjm

F.A.I. RTE.	SECTION	COUNTY	TOTAL SHEETS	SHEET NO.
57	*	DOUGLAS	76	64

* (15,21-25,21-26,27)RS-1

DETAIL OF BUTT JOINTS AT RAMPS A, B, C & D

I-57/IL 133 INTERCHANGE

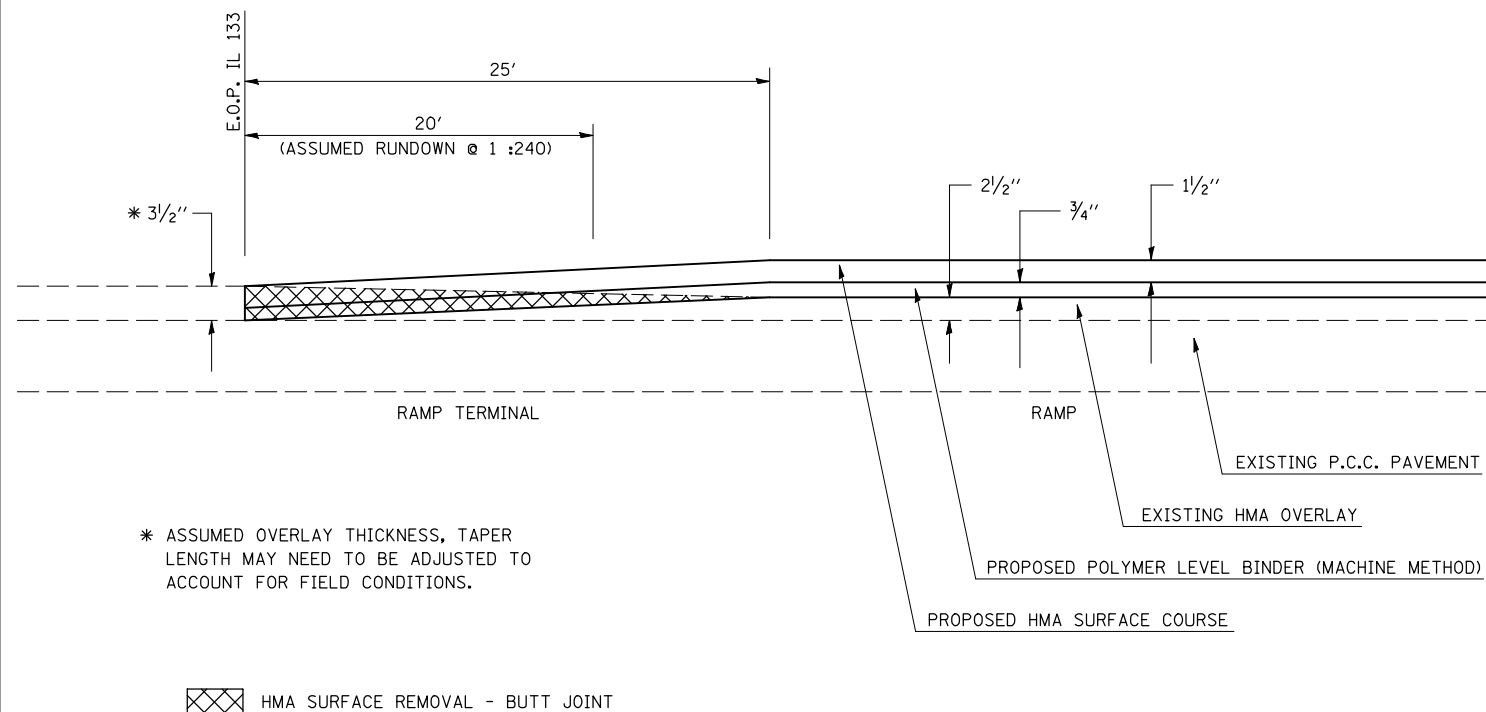

DETAIL OF BUTT JOINTS AT RAMPS A, B, C & D

I-57/US 36 INTERCHANGE

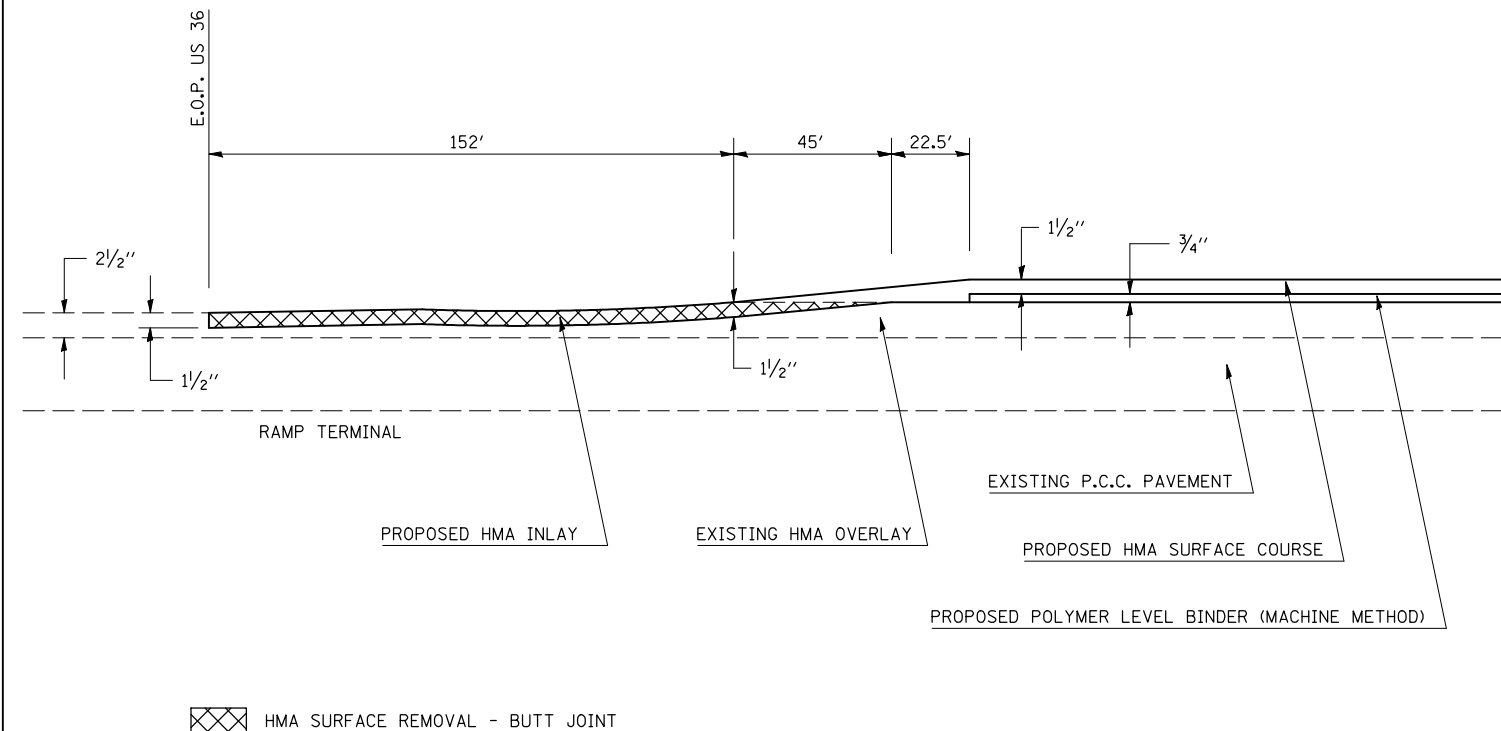

DETAIL OF HMA TRANSITION
RAMPS A, B, C & D I-57/IL 133 INTERCHANGE

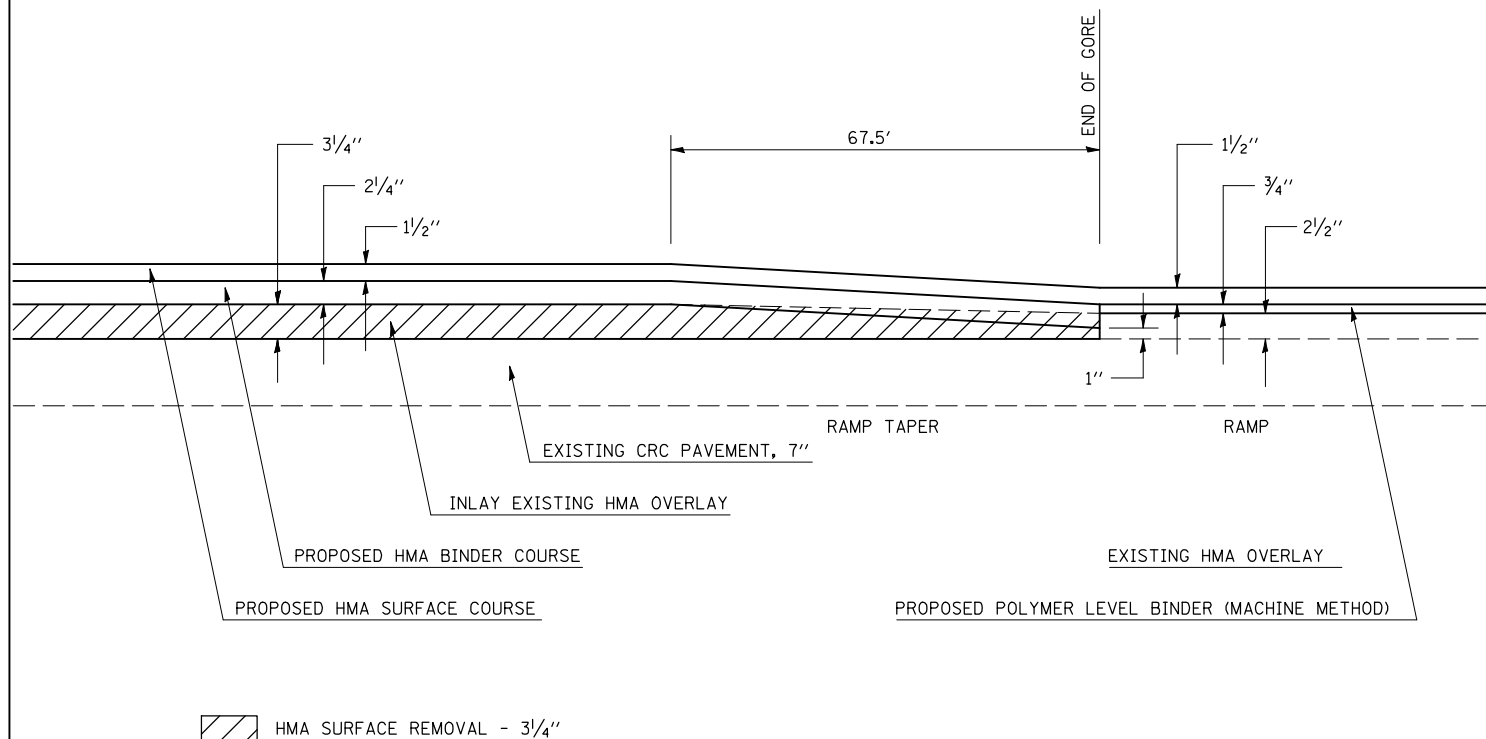

DETAIL OF HMA TRANSITION
RAMP A I-57/US 36 INTERCHANGE

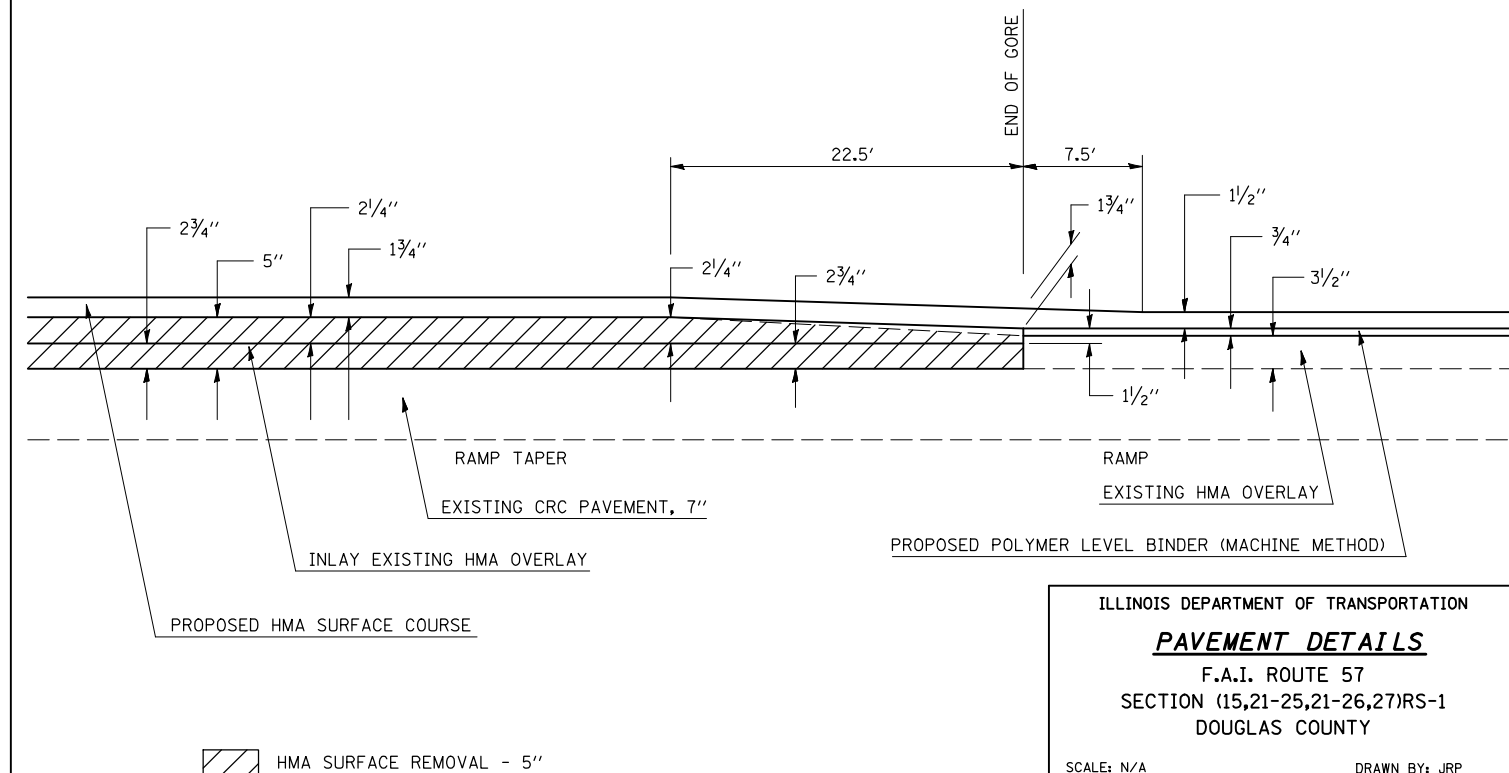

ILLINOIS DEPARTMENT OF TRANSPORTATION
PAVEMENT DETAILS
F.A.I. ROUTE 57
SECTION (15,21-25,21-26,27)RS-1
DOUGLAS COUNTY

SCALE: N/A
DATE: 07-2008

DRAWN BY: JRP
CHECKED BY: KBD

PLOT DATE = 8/21/2008
FILE NAME = c:\p\projects\45901385 (v8)\70465\detail.dgn
PLOT SCALE = 1/8"=1'-0"
USER NAME = sheehyjm

F.A.I. RTE.	SECTION	COUNTY	TOTAL SHEETS	SHEET NO.
57	*	DOUGLAS	76	65

* (15,21-25,21-26,27)RS-1

DETAIL OF HMA TRANSITION
RAMPS B & D I-57/US 36 INTERCHANGE

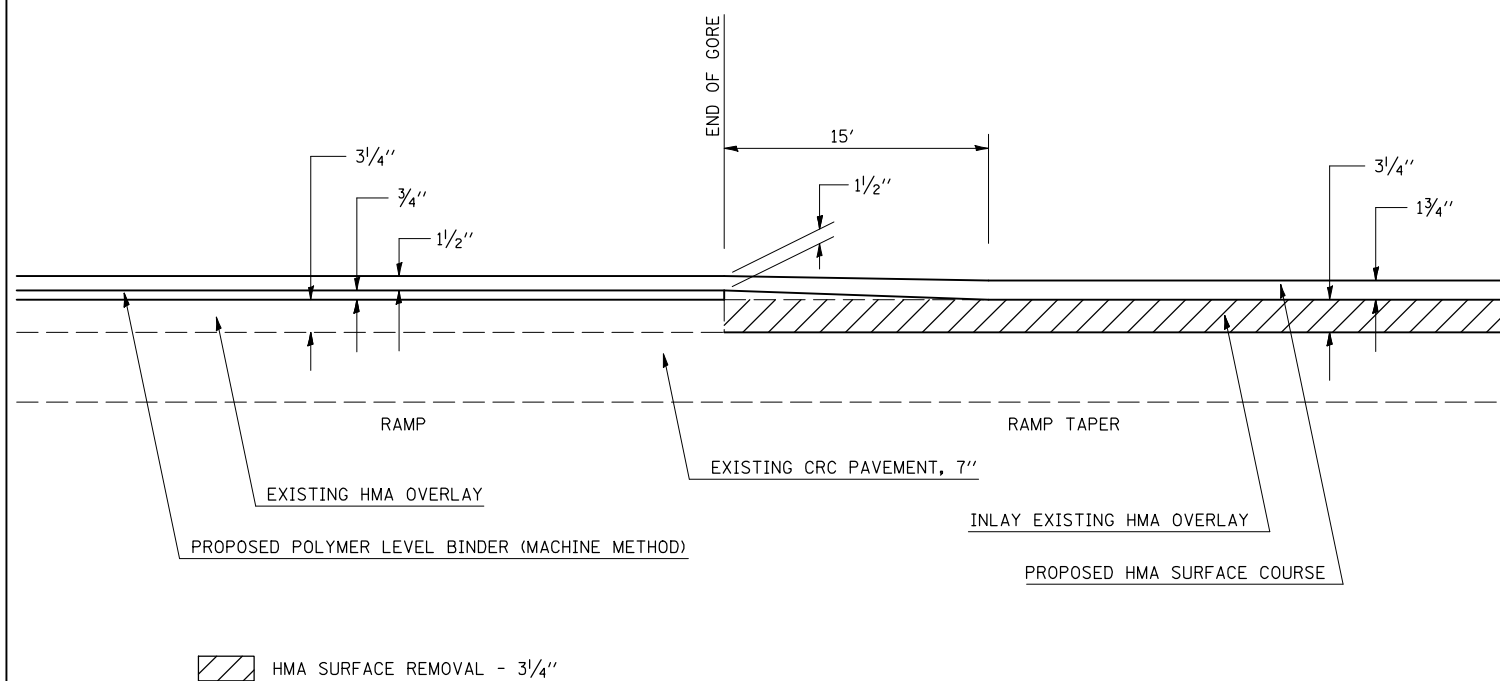

DETAIL OF HMA TRANSITION
RAMP C I-57/US 36 INTERCHANGE

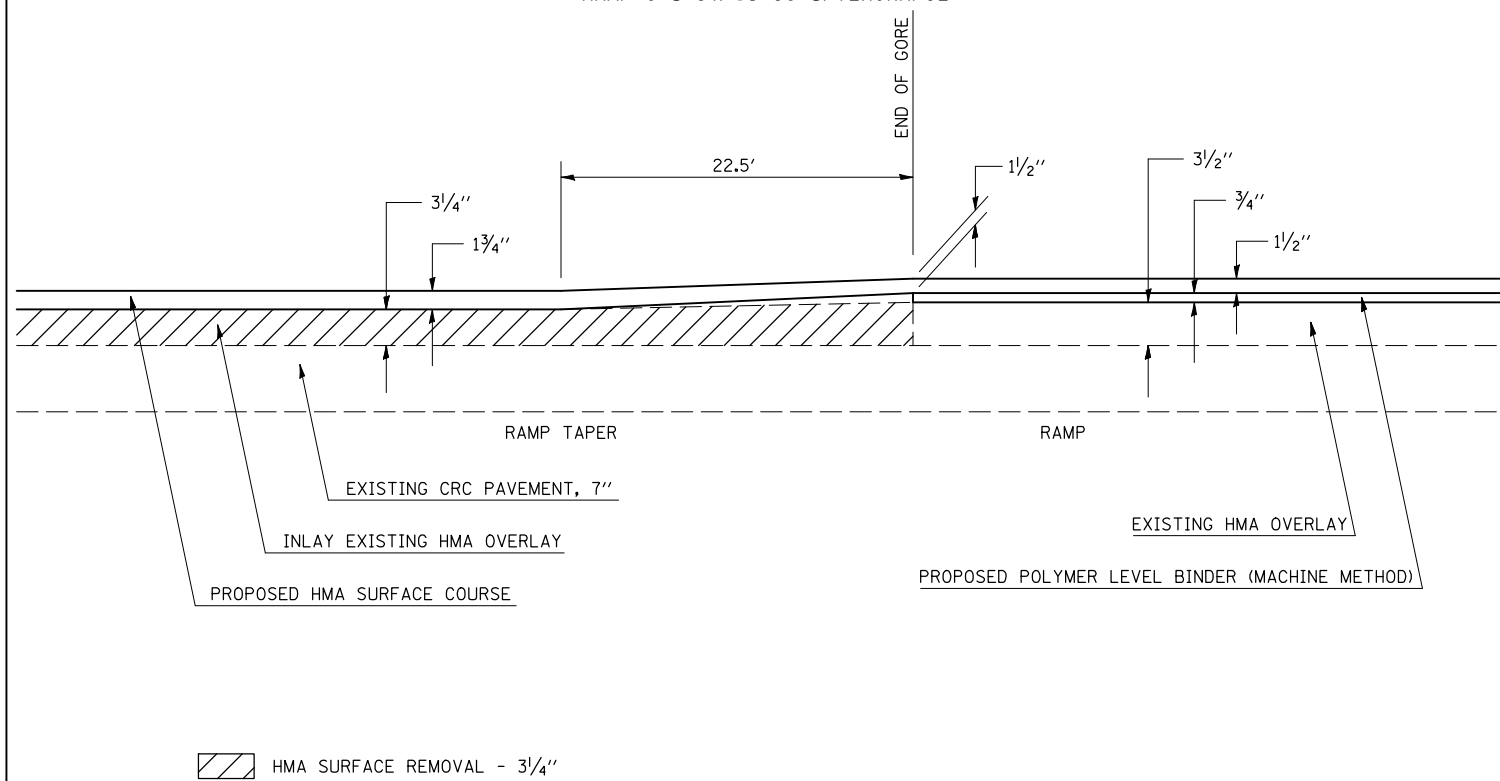

PLOT DATE = 8/21/2008
 FILE NAME = c:\projects\4591385 (v8)\70465\detail.dgn
 PLOT SCALE = 1/8"=1'-0"
 USER NAME = sheehyem

ILLINOIS DEPARTMENT OF TRANSPORTATION
PAVEMENT DETAILS
 F.A.I. ROUTE 57
 SECTION (15,21-25,21-26,27)RS-1
 DOUGLAS COUNTY

SCALE: N/A
 DATE: 07-2008

DRAWN BY: JRP
 CHECKED BY: KBD

F.A.I. RTE.	SECTION	COUNTY	TOTAL SHEETS	SHEET NO.
57	*	DOUGLAS	76	66

* (15,21-25,21-26,27)RS-1

**DETAIL OF MEDIAN CROSSOVER
TO BE RECONSTRUCTED**

STATION 1431+00

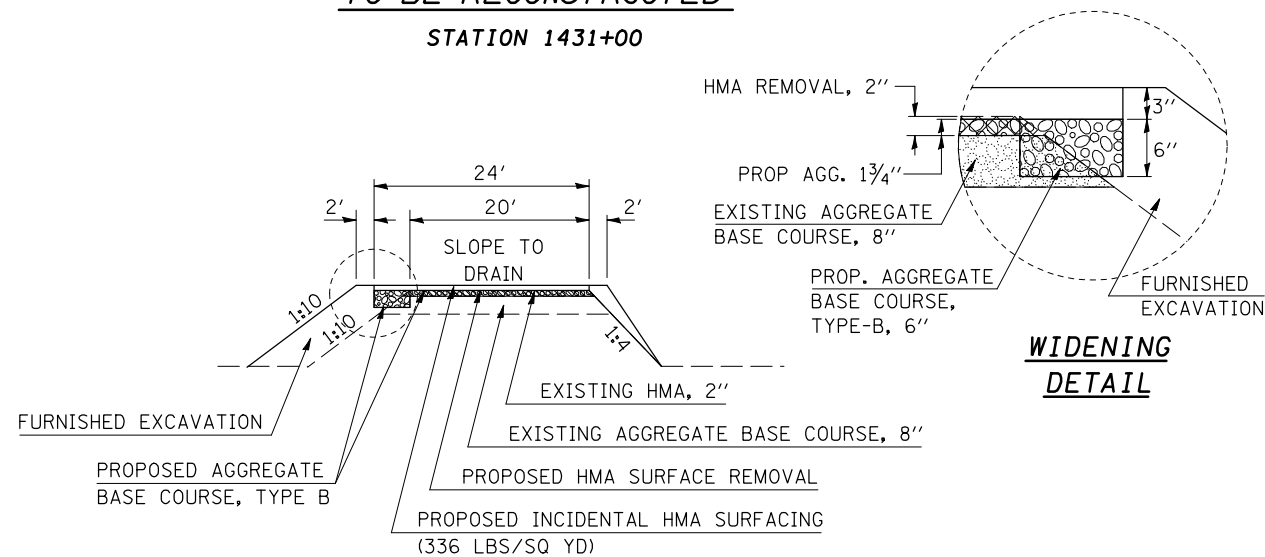

ELEVATION

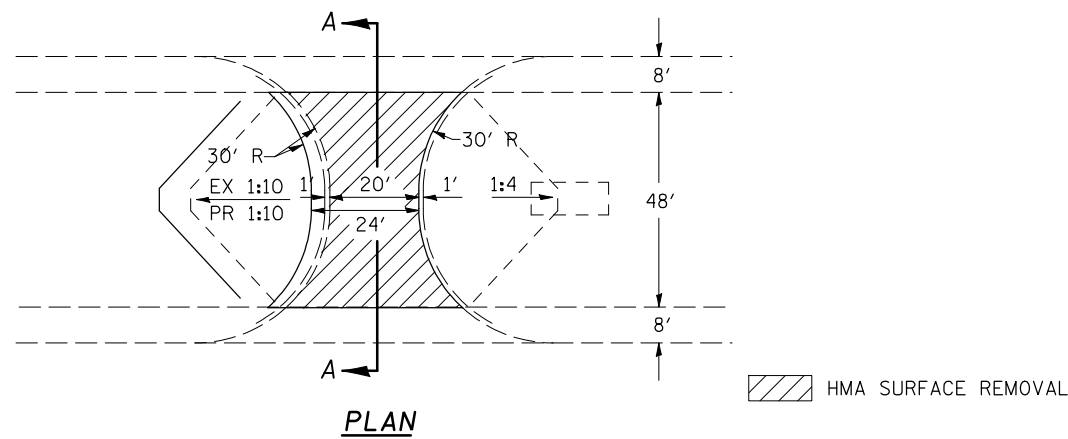

PLAN

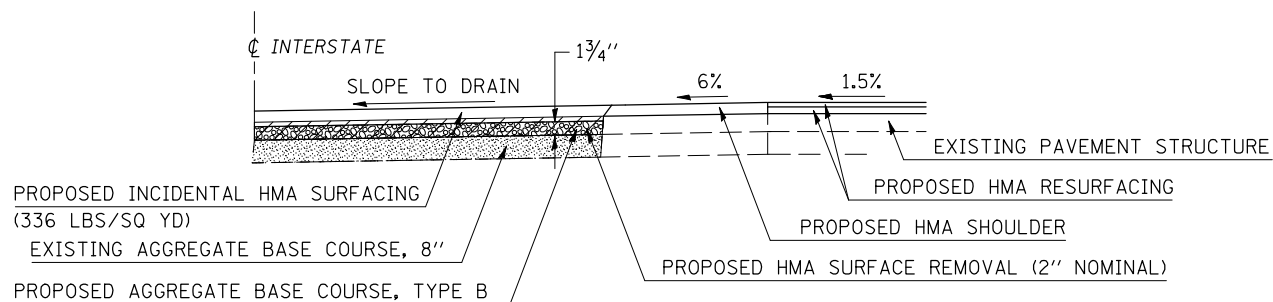

**SECTION A-A
SYMMETRICAL ABOUT CENTERLINE**

NOTES

1. OMIT RUMBLE STRIPS ON SHOULDERS THROUGHOUT MEDIAN CROSSOVER.
2. REMOVAL OF EXISTING AGGREGATE SHOULDERS IS INCIDENTAL TO THE COST OF PROPOSED 6" AGGREGATE BASE COURSE.

PLOT DATE 8/21/2008
 FILE NAME c:\projects\45801385 (v8)\70465\detaila.dgn
 PLOT SCALE 42,8824' / 1" IN.
 USER NAME sheehygm

**DETAIL OF MEDIAN CROSSOVER
TO BE RECONSTRUCTED**

STATION 142+80

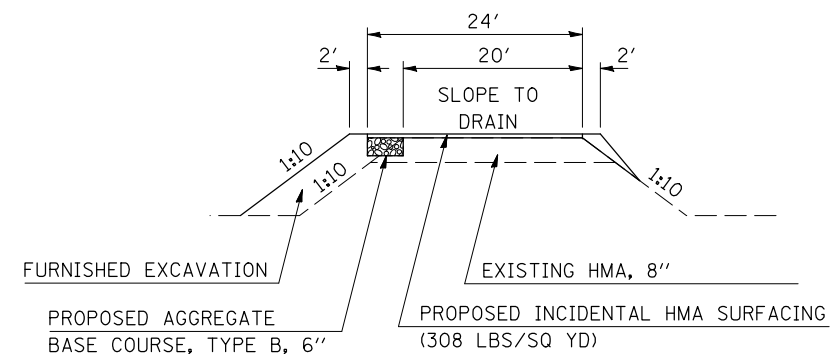

ELEVATION

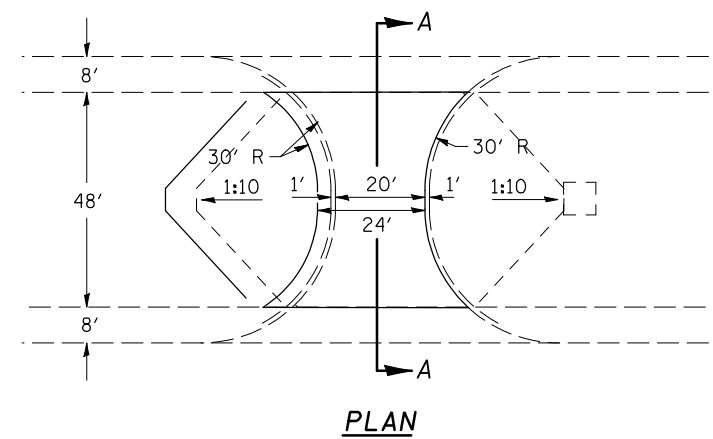

PLAN

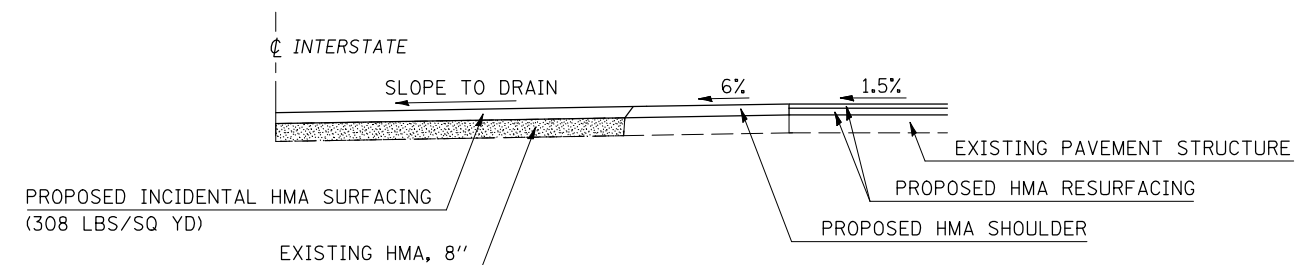

**SECTION A-A
SYMMETRICAL ABOUT CENTERLINE**

NOTES

1. OMIT RUMBLE STRIPS ON SHOULDERS THROUGHOUT MEDIAN CROSSOVER.
2. REMOVAL OF EXISTING AGGREGATE SHOULDERS IS INCIDENTAL TO THE COST OF PROPOSED 6" AGGREGATE BASE COURSE.

ILLINOIS DEPARTMENT OF TRANSPORTATION
MEDIAN CROSSOVERS
 F.A.I. ROUTE 57
 SECTION (15,21-25,21-26,27)RS-1
 DOUGLAS COUNTY

SCALE: N/A
 DATE: 07-2008

DRAWN BY: CMS
 CHECKED BY: KBD

F.A.I. RTE.	SECTION	COUNTY	TOTAL SHEETS	SHEET NO.
57	*	DOUGLAS	76	67

* (15,21-25,21-26,27)RS-1

**DETAIL OF MEDIAN CROSSOVER
TO BE RECONSTRUCTED**

STATION 293+93

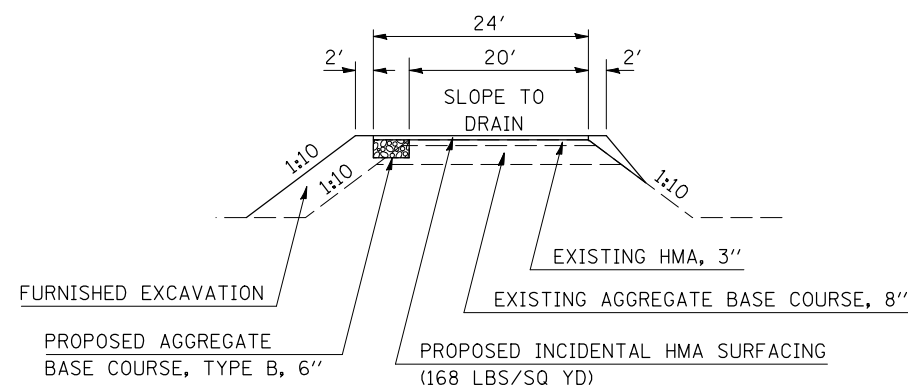

ELEVATION

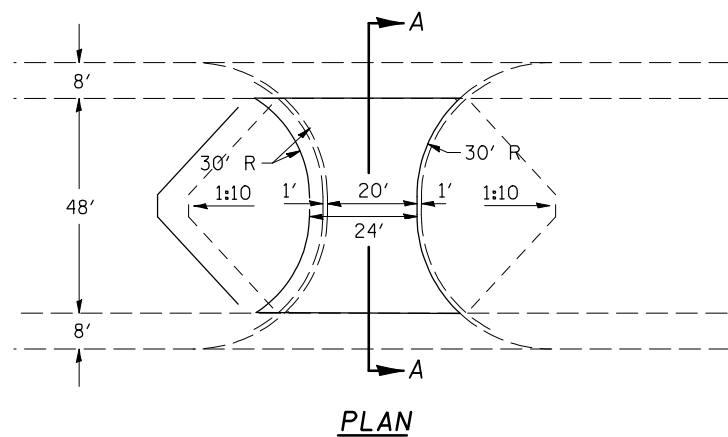

PLAN

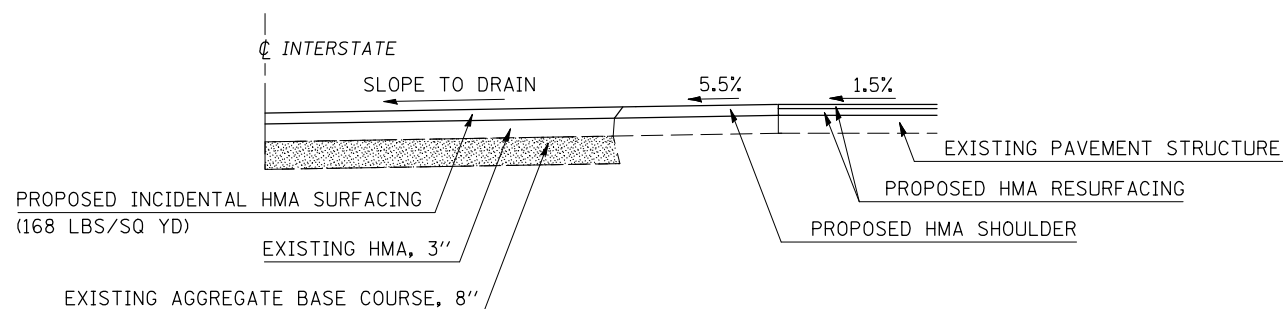

**SECTION A-A
SYMMETRICAL ABOUT CENTERLINE**

NOTES

1. OMIT RUMBLE STRIPS ON SHOULDERS THROUGHOUT MEDIAN CROSSOVER.
2. REMOVAL OF EXISTING AGGREGATE SHOULDERS IS INCIDENTAL TO THE COST OF PROPOSED 6" AGGREGATE BASE COURSE.

PLOT DATE: 8/21/2008
 FILE NAME: c:\projects\45801385 (v8)\70465\detaila.dgn
 PLOT SCALE: 42,8824' / IN.
 USER NAME: sheehyjm

**DETAIL OF MEDIAN CROSSOVER
TO BE RECONSTRUCTED**

STATION 478+54

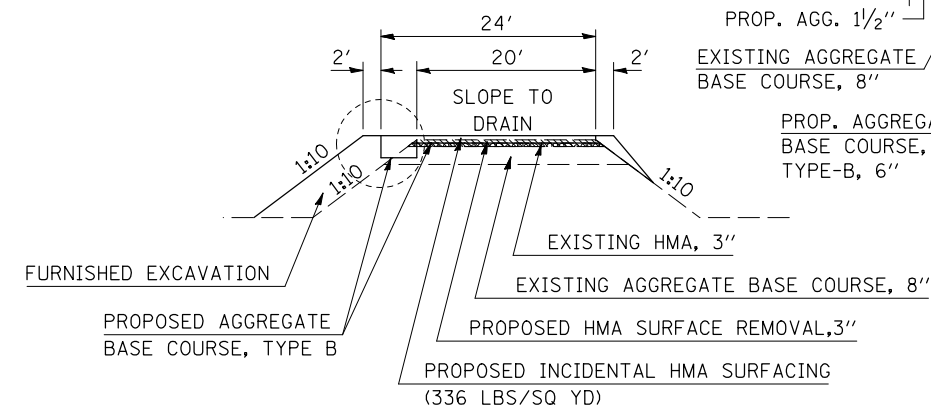

ELEVATION

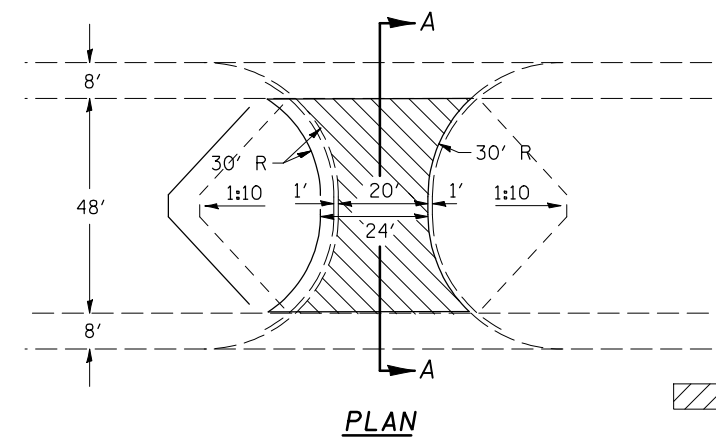

PLAN

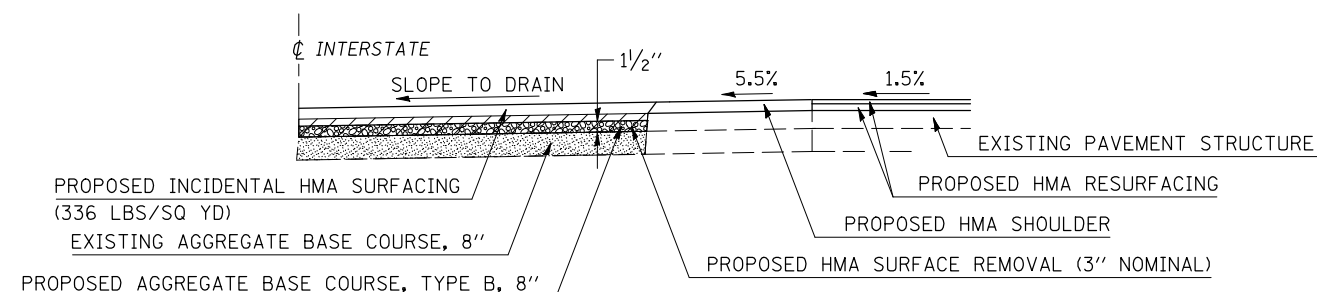

**SECTION A-A
SYMMETRICAL ABOUT CENTERLINE**

NOTES

1. OMIT RUMBLE STRIPS ON SHOULDERS THROUGHOUT MEDIAN CROSSOVER.
2. REMOVAL OF EXISTING AGGREGATE SHOULDERS IS INCIDENTAL TO THE COST OF PROPOSED 6" AGGREGATE BASE COURSE.

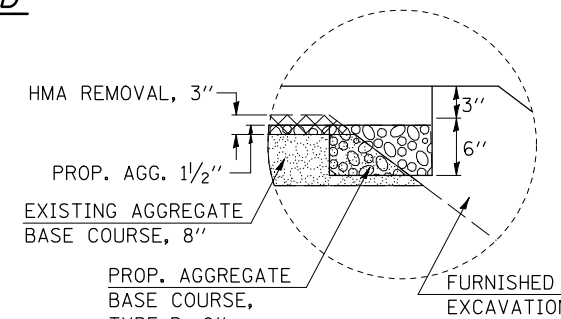

**WIDENING
DETAIL**

ILLINOIS DEPARTMENT OF TRANSPORTATION
MEDIAN CROSSOVERS
 F.A.I. ROUTE 57
 SECTION (15,21-25,21-26,27)RS-1
 DOUGLAS COUNTY

SCALE: N/A
 DATE: 07-2008

DRAWN BY: CMS
 CHECKED BY: KBD

F.A.I. RTE.	SECTION	COUNTY	TOTAL SHEETS	SHEET NO.
57	*	DOUGLAS	76	68

* (15,21-25,21-26,27)RS-1

IDENTIFICATION OF ROADSIDE HAZARDS FOR TWO-LANE ROADWAYS

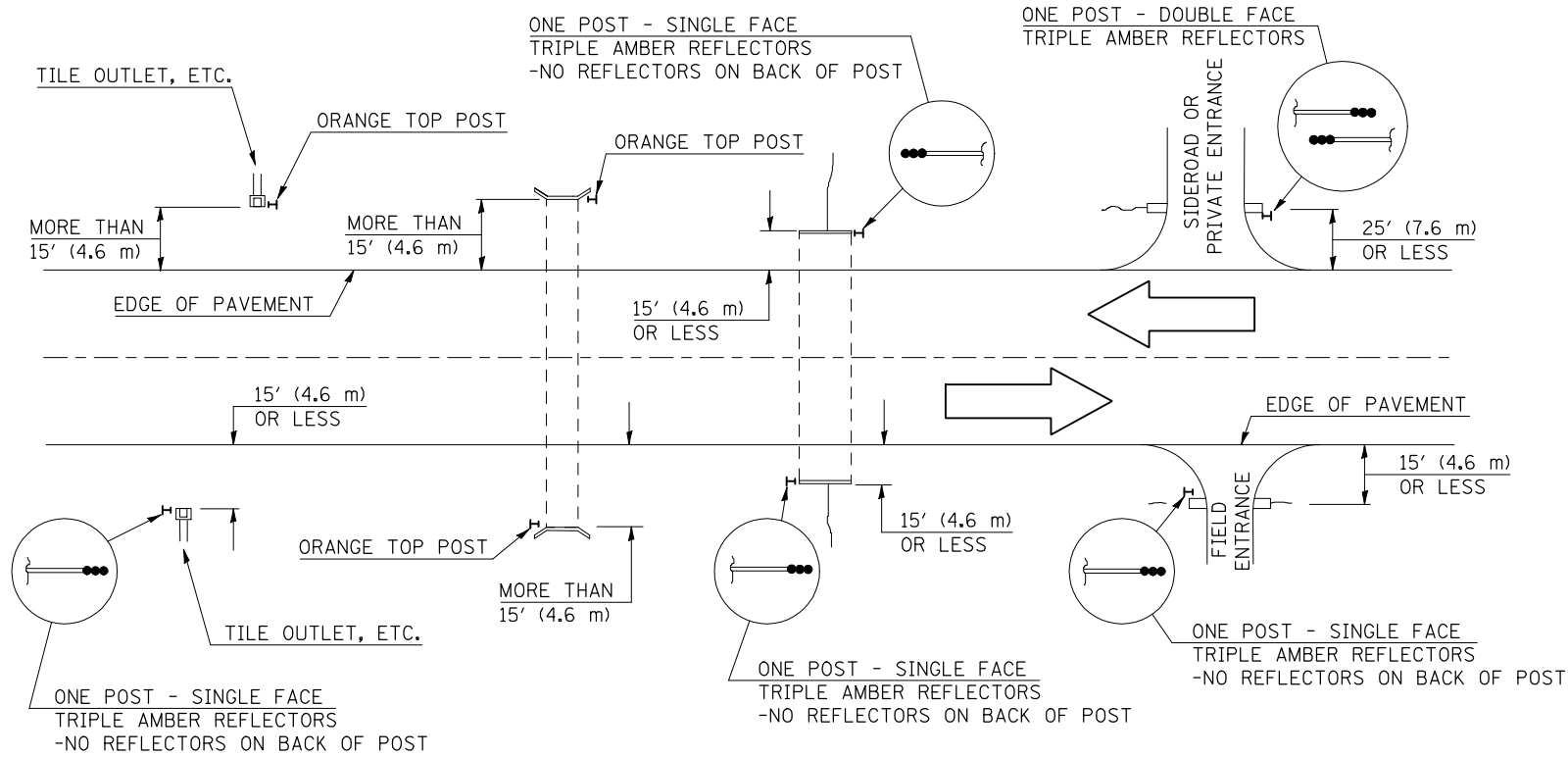

BILL OF MATERIALS

DELINEATOR TYPE	SINGLE FACE	DOUBLE FACE	NO REFLECTOR	TOTAL DELINEATORS
SINGLE CRYSTAL	95.0	N/A	N/A	95.0
DOUBLE CRYSTAL	52.0		N/A	52.0
SINGLE AMBER	71.0		N/A	71.0
DOUBLE AMBER	8.0	N/A	N/A	8.0
TRIPLE AMBER	8.0		N/A	8.0
ORANGE TOP	N/A	N/A		---
			TOTAL	234.0

NOTES

DELINEATORS FOR ROADSIDE HAZARDS SHALL ONLY BE PLACED AT LOCATIONS WHERE THERE IS NO GUARDRAIL, OR OTHER PERMANENT BARRIER, ON THE SAME SIDE OF ROAD AS THE HAZARD.

DELINEATORS FOR ROADSIDE HAZARDS SHALL ONLY BE PLACED AT LOCATIONS WHERE DELINEATORS ARE NOT IN PLACE ALONG THE EDGE OF SHOULDER.

EACH POST SHALL BE CONSIDERED AS ONE DELINEATOR FOR PAYMENT, REGARDLESS OF THE NUMBER OF DELINEATORS ATTACHED TO IT.

POSTS INDICATED AS "ORANGE TOP" SHALL HAVE NO REFLECTORS. THEY SHALL HAVE THE TOP 12" (300 mm) (MINIMUM) OF THE POST PAINTED A BRIGHT ORANGE COLOR SIMILAR TO CONSTRUCTION SIGNS, AND SHALL MEET THE APPROVAL OF THE ENGINEER. FLUORESCENT PAINT OR OTHER SPECIAL RETROREFLECTIVE COATINGS WILL NOT BE REQUIRED.

FOR ONE-WAY ROADWAYS THE APPLICATION SHALL BE SIMILAR WITH DELINEATORS PLACED ON THE TRAFFIC APPROACH SIDE OF HAZARDS AND OBJECTS. ONLY SINGLE FACE DELINEATORS WILL BE REQUIRED ON ONE-WAY ROADWAYS.

FOR OTHER DELINEATOR APPLICATIONS, REFER TO HIGHWAY STANDARD 635001.

MEDIAN DELINEATORS AT CROSSOVER
(FOR INTERSTATES, EXPRESSWAYS, DUAL HIGHWAYS)

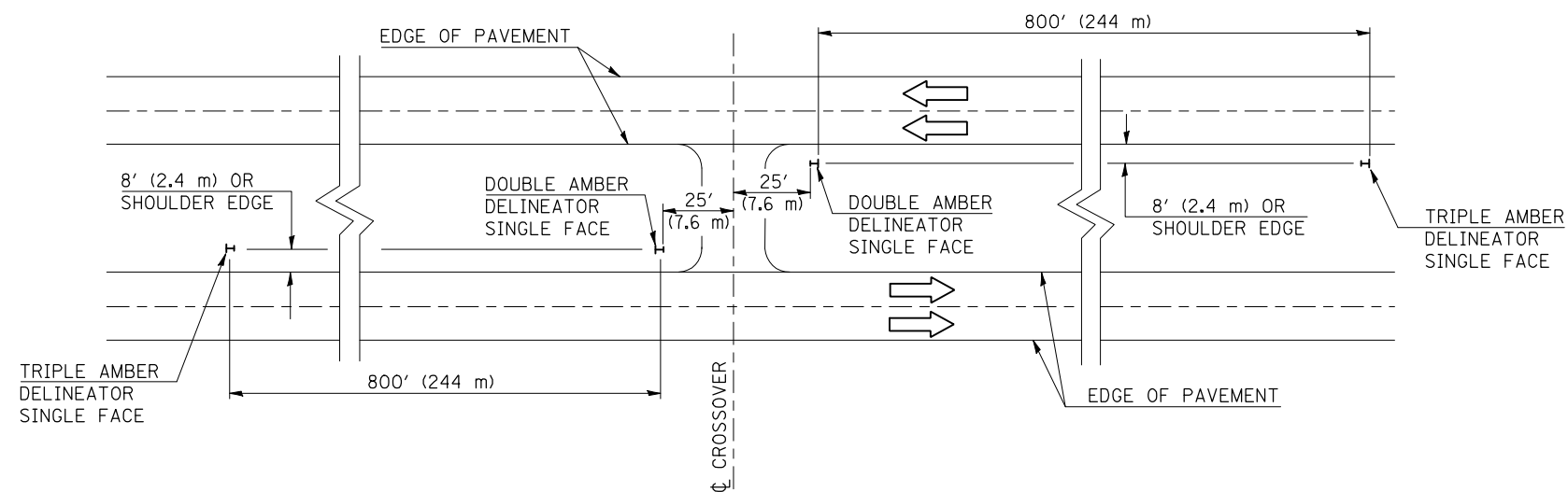

Note: All dimensions are in INCHES (millimeters) unless otherwise shown.

DATE	REVISIONS	NAME
12/06	REPLACED DETAIL F-5.13	TJB

ILLINOIS DEPARTMENT OF TRANSPORTATION

DELINEATORS

DISTRICT 5 DETAIL NO. 63500105

F.A.I. RTE.	SECTION	COUNTY	TOTAL SHEETS	SHEET NO.
57	*	DOUGLAS	76	69

* (15,21-25,21-26,27)RS-1

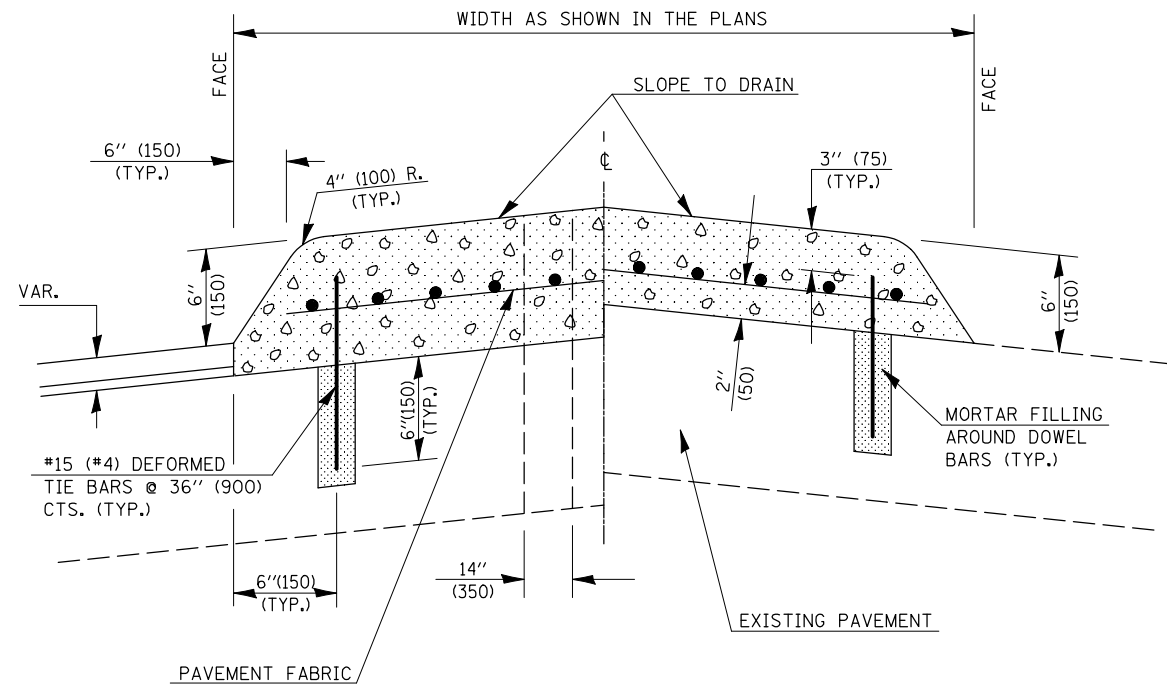

SECTION A-A

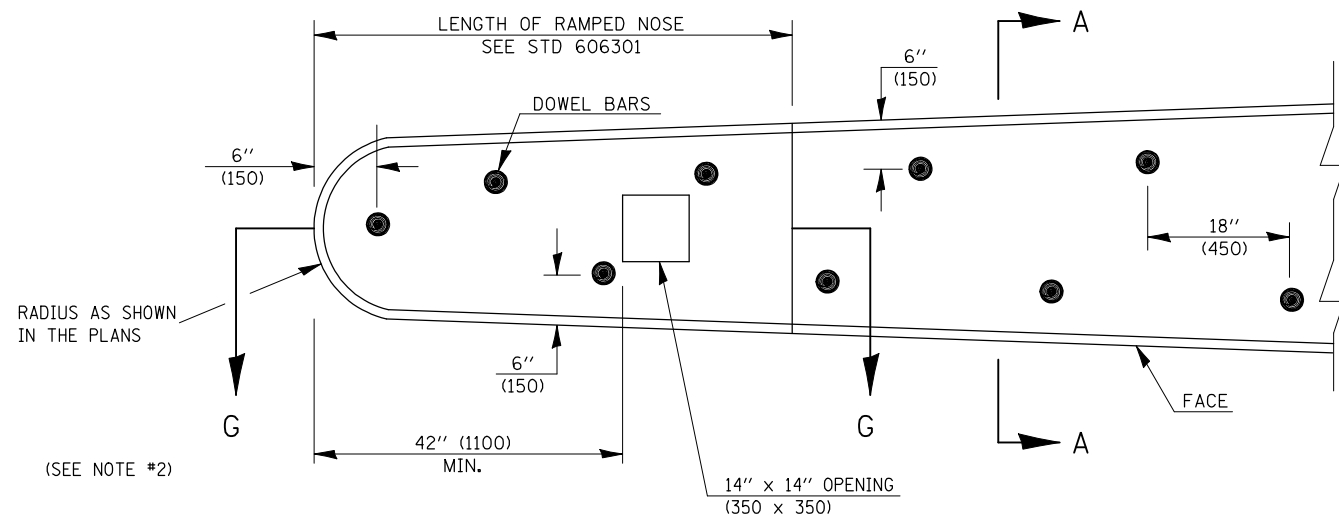

PLAN OF MEDIAN

GENERAL NOTES

1. THE GENERAL NOTES FOR STANDARD 606301 SHALL APPLY.
2. DOWEL BARS @ 36" (900) CTS. OR AS DIRECTED BY THE ENGINEER.
3. THIS WORK WILL BE PAID FOR AT THE CONTRACT UNIT PRICE PER SQ FOOT (m²) FOR CONCRETE MEDIAN, TYPE SM-6 (SM-15) (DOWELED), INCLUDING THE COST OF FURNISHING AND INSTALLING THE DOWEL BARS, MORTAR FILLING, PAVEMENT FABRIC AND THE REMOVAL AND DISPOSAL OF THE EXISTING PAVEMENT FOR THE 14" x 14" (350 x 350) OPENING, IF REQUIRED, AND NO ADDITIONAL COMPENSATION WILL BE ALLOWED.

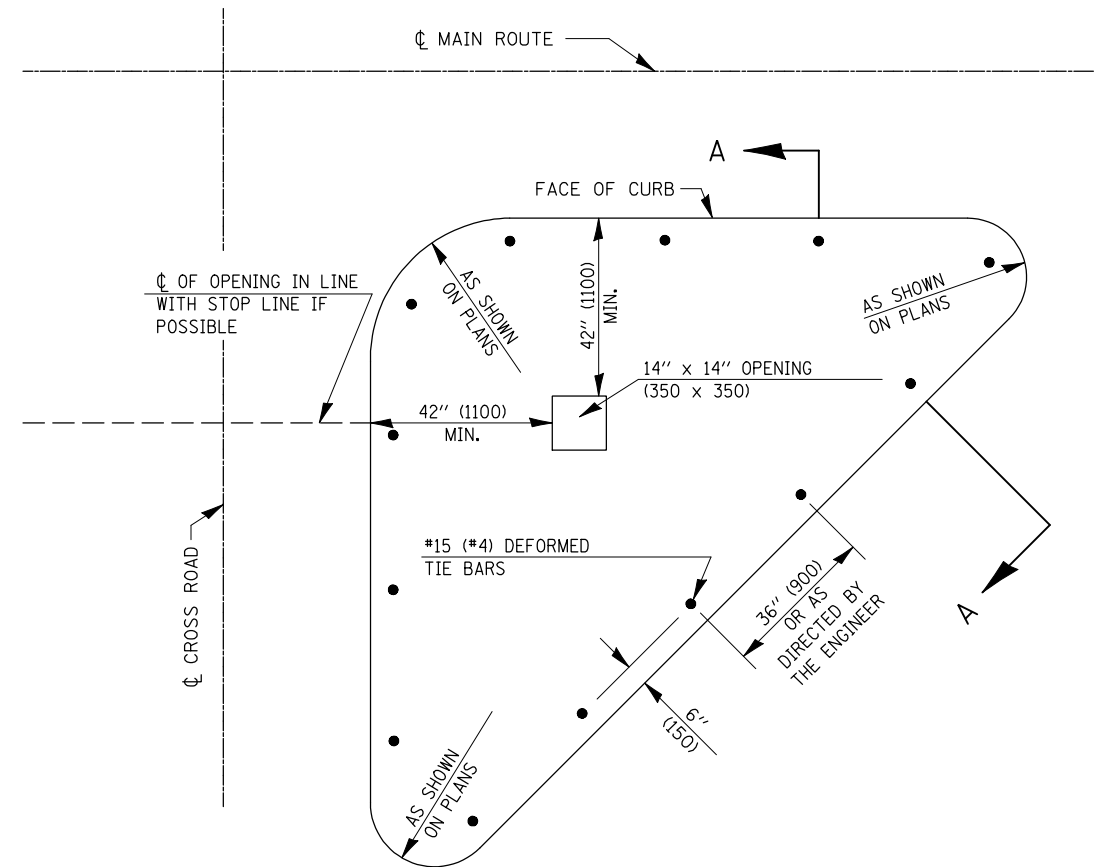

PLAN OF CORNER ISLAND

Note: All dimensions are in INCHES (millimeters) unless otherwise shown.

DATE	REVISIONS	NAME	ILLINOIS DEPARTMENT OF TRANSPORTATION
11/06	REPLACED DETAIL A-5.07	TJB	

**CONCRETE MEDIAN,
TYPE SM-6 (SM-15)
(DOWELED)**

DISTRICT 5 DETAIL NO. 60622354

F.A.I. RTE.	SECTION	COUNTY	TOTAL SHEETS	SHEET NO.
57	*	DOUGLAS	76	70

* (15,21-25,21-26,27)RS-1

RESURFACED PCC PAVEMENT

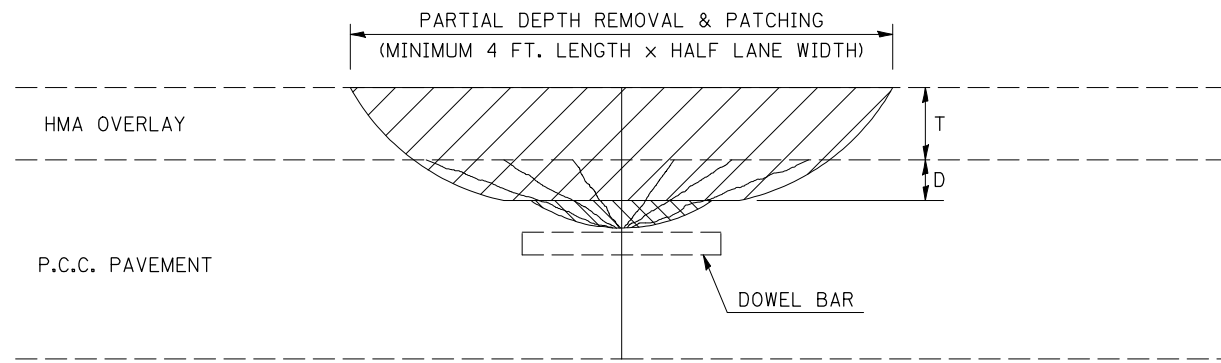

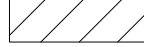
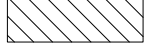
 +  = PARTIAL DEPTH REMOVAL (X4401705)
 MILL MACHINE AND/OR WHEEL SAW REMOVAL AIR EQUIPMENT OR MECHANICAL SWEEPER REMOVAL OF LOOSE AND/OR UNSOUND CONCRETE

DESIGN NOTES

PARTIAL DEPTH HMA PATCHING SHALL NOT BE USED WHEN HMA OVERLAY THICKNESS (T) ON PCC PAVEMENT EXCEEDS 4 3/4 INCHES (145 mm) OR ON CRC PAVEMENT.

GENERAL NOTES

ALL VOLUME OF PARTIAL DEPTH REMOVAL SHALL BE REPLACED WITH HOT-MIX ASPHALT (HMA) AND PAID FOR AT THE CONTRACT UNIT PRICE PER TON FOR PARTIAL DEPTH PATCHING.

T = THICKNESS OF HMA OVERLAY(S). SEE EXISTING TYPICAL CROSS SECTION.

GENERAL NOTE 406H SHALL INCLUDE MIXTURE REQUIREMENTS FOR PARTIAL DEPTH PATCHING.

HMA REPLACEMENT IN RESURFACED PCC PAVEMENT LOCATIONS SHALL BE ACCORDING TO SECTION 406 OF THE STANDARD SPECIFICATIONS.

D = DEPTH OF PARTIAL DEPTH REMOVAL INTO EXISTING PCC PAVEMENT. (3" (75 mm) ± OR TO SOUND CONCRETE)

TRANSVERSE CONTRACTION JOINT SHOWN - OTHER LOCATIONS SIMILAR.

BARE PCC PAVEMENT

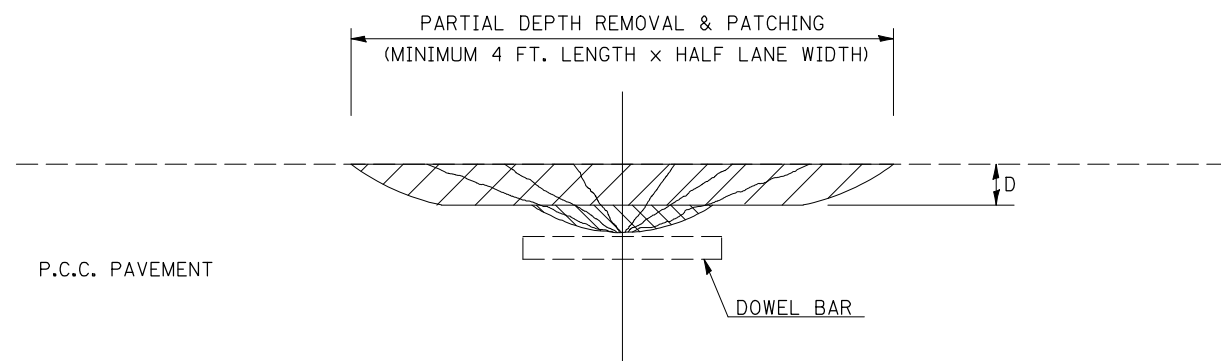

Note: All dimensions are in INCHES (millimeters) unless otherwise shown.

DATE	REVISIONS	NAME	ILLINOIS DEPARTMENT OF TRANSPORTATION
11/06	REPLACED DETAIL C-5.01	TJB	PCC PARTIAL DEPTH HOT-MIX ASPHALT PATCHING
			DISTRICT 5 DETAIL NO. XX442100

F.A.I. RTE.	SECTION	COUNTY	TOTAL SHEETS	SHEET NO.
57	*	DOUGLAS	76	71

* (15,21-25,21-26,27)RS-1

**APPLICATION NO. 1
DAY OPERATION ONLY
PARTIAL RAMP CLOSURE**

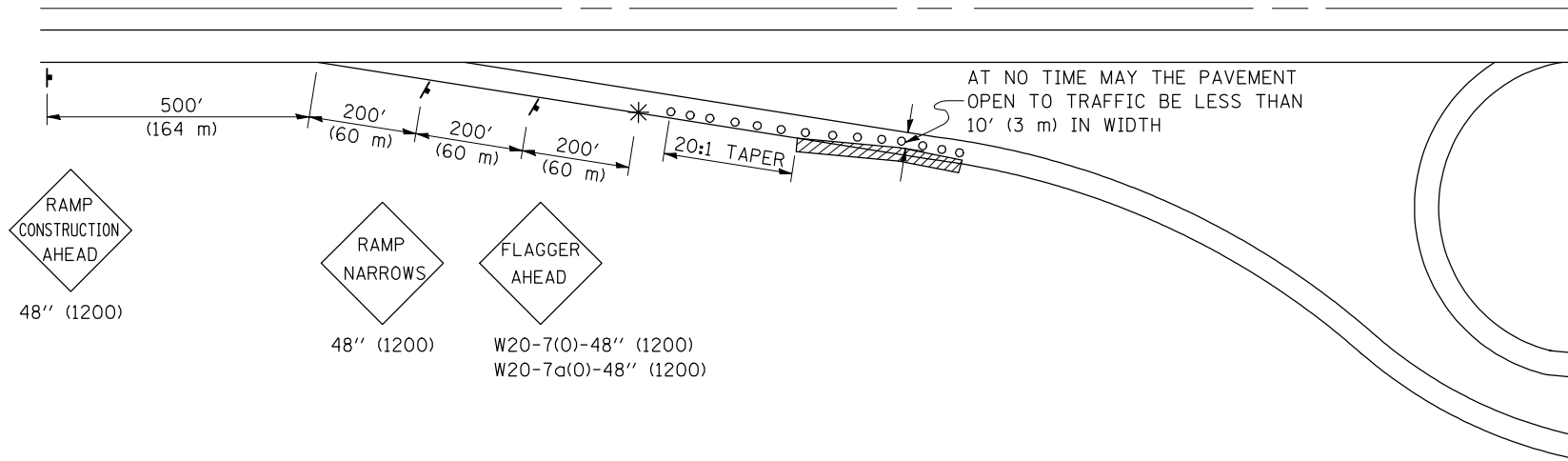

SYMBOLS

- (APPLICATION NO. 1) TYPE I OR II BARRICADES OR DRUMS @ 50' (15 m) CTS.
- ⦿ (APPLICATION NO. 2) TYPE I OR II BARRICADES OR DRUMS @ 25' (7.5 m) CTS. W/STEADY BURNING LIGHTS
- * (APPLICATION NO. 1) FLAGGER PLACED AS DIRECTED BY THE ENGINEER
- † SIGN ON PORTABLE OR PERMANENT SUPPORT
- ▨ WORK AREA

TYPICAL APPLICATIONS

- PAVEMENT PATCHING
- PIPE UNDERDRAINS
- HMA RESURFACING

GENERAL NOTES

CONSTRUCTION OPERATIONS SHALL BE CONFINED TO AN AREA NARROW ENOUGH THAT A MINIMUM OF 10' (3 m) OF PAVEMENT SHALL BE OPEN TO TRAFFIC AT ALL TIMES.

FULL WIDTH PAVEMENT ON THE RAMPS SHALL BE OPEN TO TRAFFIC AT NIGHT.

WHEN NO WORK IS BEING PERFORMED, THE FLAGGER WILL NOT BE REQUIRED. IF THE FLAGGER IS NOT PRESENT, THE FLAGGER SIGNS SHALL BE REMOVED OR COVERED.

ALL SIGNS SHALL BE POST MOUNTED IF WORK IN THE AREA EXCEEDS FOUR DAYS OF DAYTIME OPERATIONS.

LONGITUDINAL DIMENSIONS MAY BE ADJUSTED SLIGHTLY TO FIT FIELD CONDITIONS.

ALL VEHICLES, EQUIPMENT, WORKERS (EXCEPT FLAGGER) AND THEIR ACTIVITIES ARE RESTRICTED AT ALL TIMES TO ONE SIDE OF THE PAVEMENT UNLESS OTHERWISE AUTHORIZED BY THE DISTRICT ENGINEER.

Traffic Control for all ramps shall be in accordance with the appropriate application of plan detail TRAFFIC CONTROL FOR RAMPS and will not be paid for separately, but shall be included in the contract lump sum prices for Traffic Control and Protection, Standard 701401 and Traffic Control and Protection, Standard 701406.

**APPLICATION NO. 2
RAMP CLOSURE**

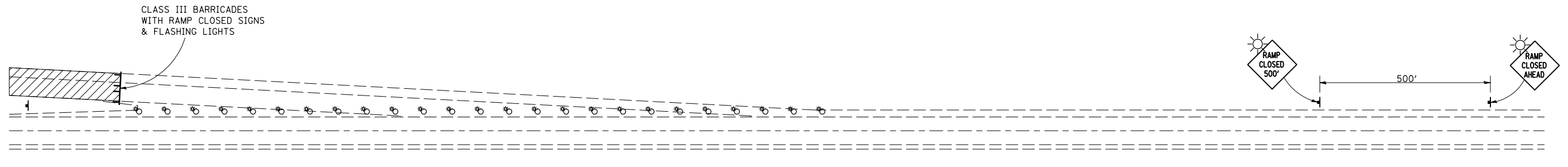

GENERAL NOTES

STEADY BURN LIGHTS ARE NOT REQUIRED FOR DAYTIME OPERATIONS.

CONTACT THE DISTRICT TRAFFIC OPERATIONS ENGINEER AT 217-465-4181, ONE WEEK PRIOR TO CLOSING THE RAMP.

Note: All dimensions are in INCHES (millimeters) unless otherwise shown.

DATE	REVISIONS	NAME
11/06	REPLACED DETAIL F-5.01	TJB

ILLINOIS DEPARTMENT OF TRANSPORTATION
TRAFFIC CONTROL FOR RAMPS
DISTRICT 5 DETAIL NO. 70103710

F.A.I. RTE.	SECTION	COUNTY	TOTAL SHEETS	SHEET NO.
57	*	DOUGLAS	76	72

* (15,21-25,21-26,27)RS-1

CENTERLINE INTERSTATE OR MULTI-LANE TWO WAY DIVIDED HIGHWAY

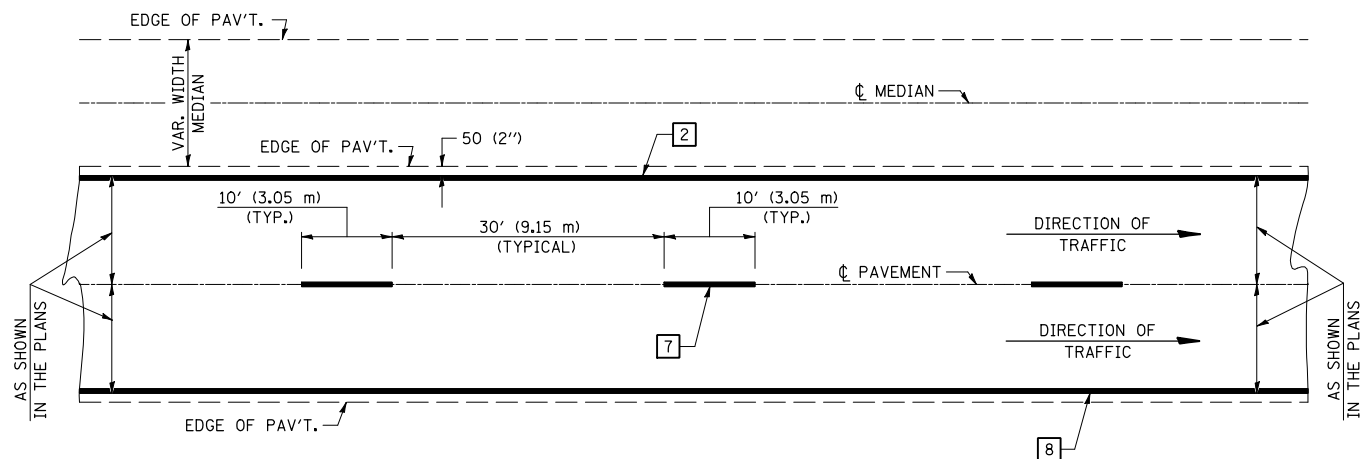

NOTE: PAVEMENT MARKINGS ARE TO BE EXTENDED THROUGH OMISSIONS WHEN APPLICABLE.

NOTE: SEE ARTICLES 780.04 & 781.03 FOR LOCATION OF STRIPES AND MARKERS RELATIVE TO EDGES OR JOINTS.

FOR RAISED REFLECTIVE PAVEMENT MARKERS, REFER TO STANDARD 781001.

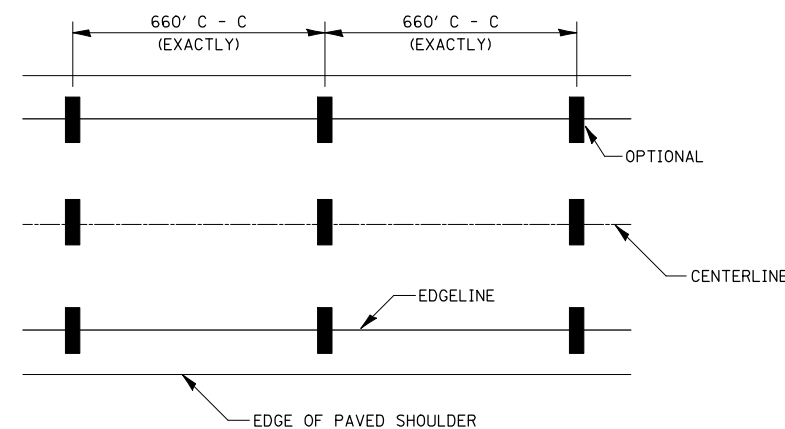

IT WILL BE NECESSARY TO HAVE A REPRESENTATIVE OF THE STATE POLICE PRESENT SO THAT THE ACCURACY OF MEASUREMENT CAN BE ATTESTED TO IN COURT.

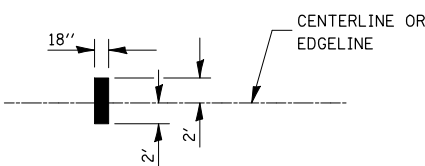

AERIAL SPEED CHECK ZONES

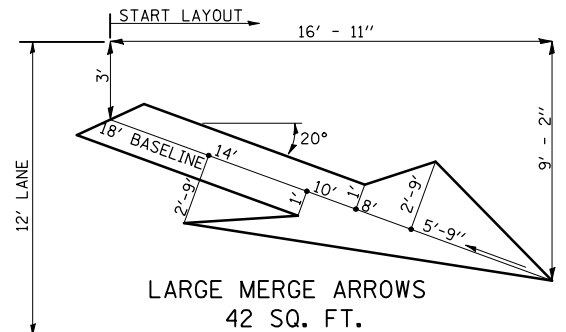

**LARGE MERGE ARROWS
42 SQ. FT.**

TYPICAL PAVEMENT MARKING LEGEND

- 1 4" (100) SKIP-DASH (YELLOW)
- 2 4" (100) SOLID (YELLOW)
- 3 12" (300) DIAGONAL (YELLOW)
- 4 4" (100) DOUBLE YELLOW (NARROW)
- 5 RESERVED
- 6 RESERVED
- 7 4" (100) SKIP-DASH (WHITE)
- 8 4" (100) SOLID (WHITE)
- 9 12" (300) DIAGONAL (WHITE)
- 10 6" (150) SOLID (WHITE)
- 11 24" (600) STOP BAR (WHITE)
- 12 8" (200) SOLID (WHITE)
- 13 4" (100) LANE LINE EXTENSIONS (WHITE)

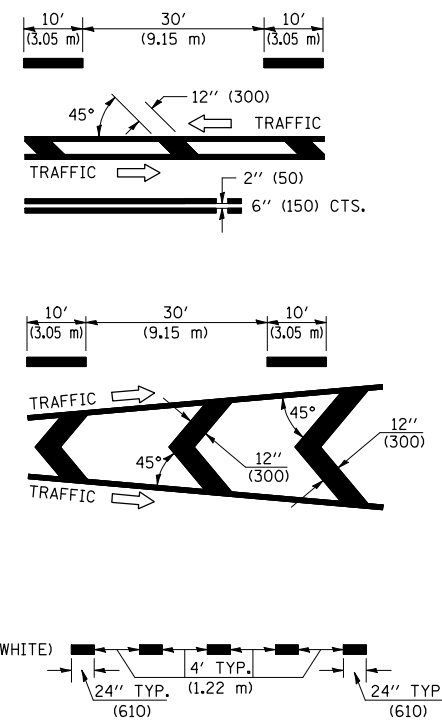

TYPICAL EXIT RAMP TERMINAL

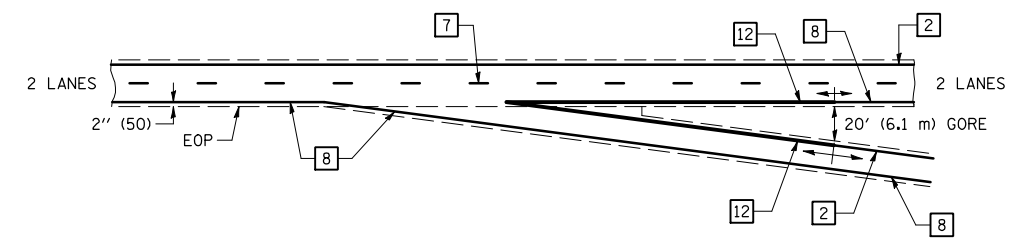

EXIT RAMP TERMINAL with EXCLUSIVE (auxiliary) LANE

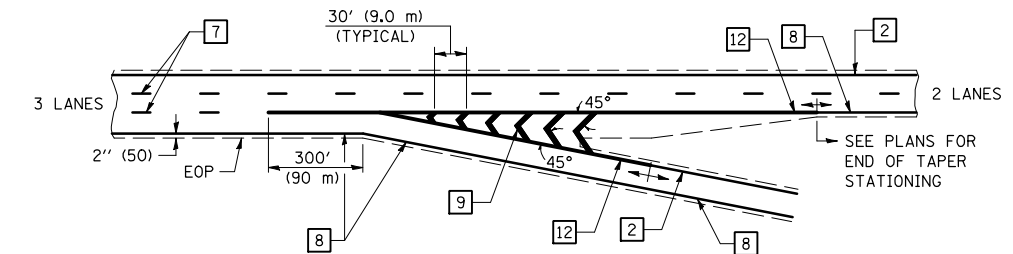

TYPICAL ENTRANCE RAMP TERMINAL

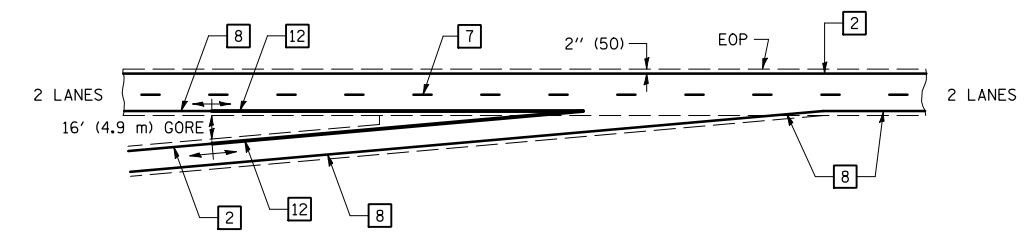

ENTRANCE RAMP TERMINAL with EXCLUSIVE LANE

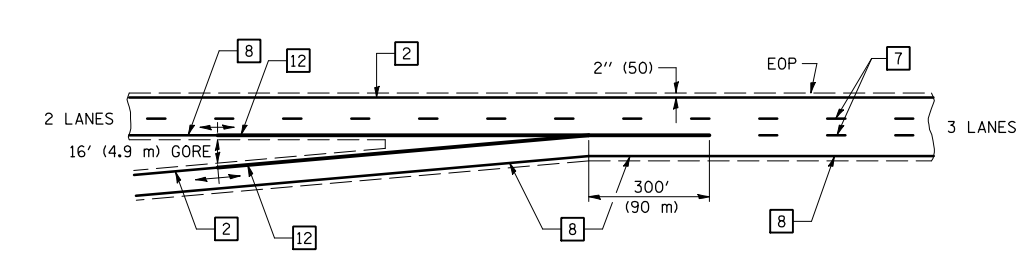

Note: All dimensions are in INCHES (millimeters) unless otherwise shown.

DATE	REVISIONS	NAME
11/06	REPLACED DETAIL F-5.22	TJB

ILLINOIS DEPARTMENT OF TRANSPORTATION
**PAVEMENT MARKING
(INTERSTATE & MULTI-LANE APPLICATIONS)**
DISTRICT 5 DETAIL NO. 7800BBBB

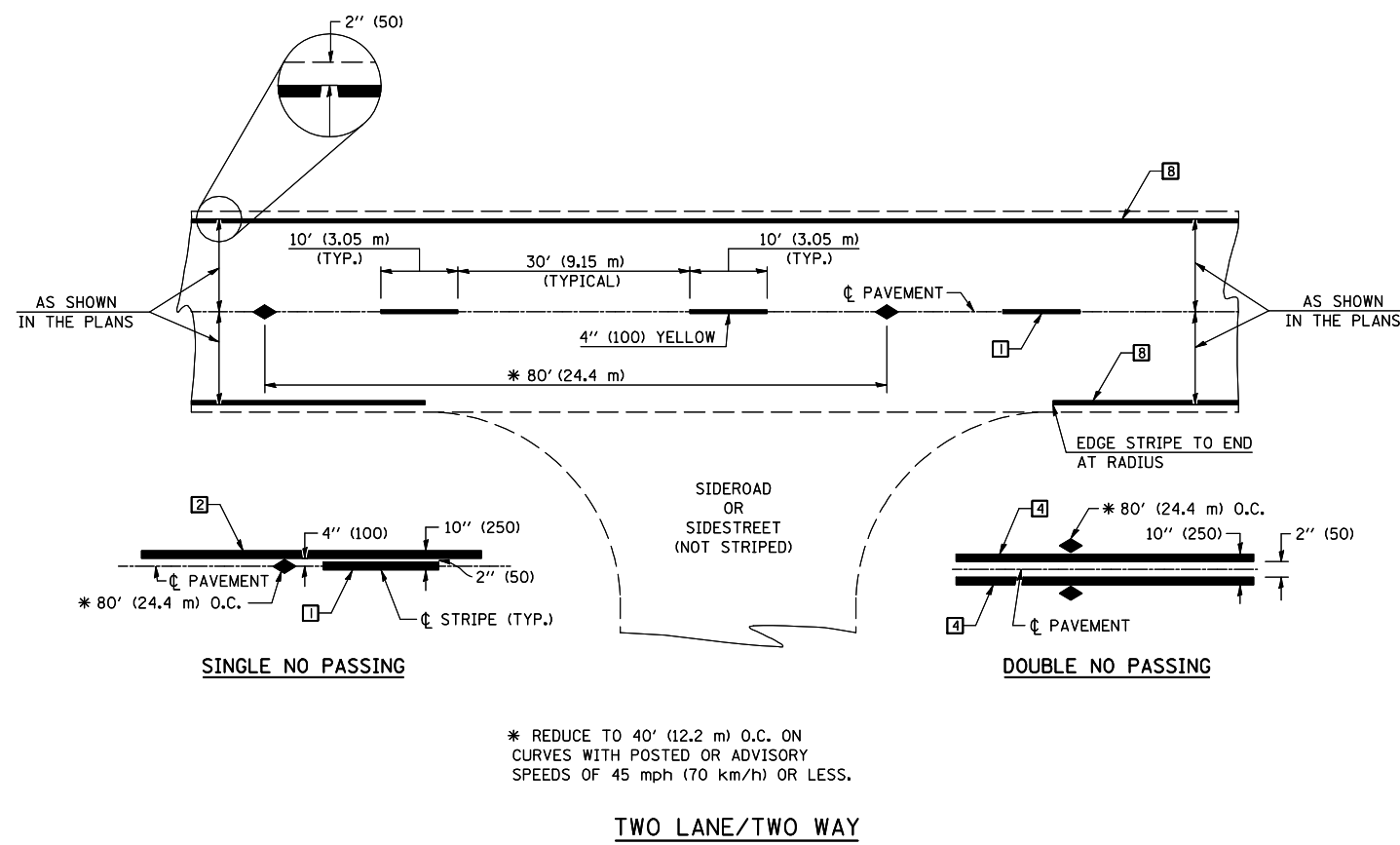

TYPICAL PAVEMENT MARKING LEGEND

- 1 4" (100) SKIP-DASH (YELLOW)
- 2 4" (100) SOLID (YELLOW)
- 3 12" (300) DIAGONAL (YELLOW)
- 4 4" (100) DOUBLE YELLOW (NARROW)
- 5 RESERVED
- 6 RESERVED
- 7 4" (100) SKIP-DASH (WHITE)
- 8 4" (100) SOLID (WHITE)
- 9 12" (300) DIAGONAL (WHITE)
- 10 6" (150) SOLID (WHITE)
- 11 24" (600) STOP BAR (WHITE)
- 12 8" (200) SOLID (WHITE)
- 13 4" (100) LANE LINE EXTENSIONS (WHITE)
- 14 4" (100) PARKING WHITE

TYPICAL PAVEMENT MARKERS LEGEND

- ◆ TWO-WAY AMBER MARKER
- ▶ ONE-WAY AMBER MARKER
- ▷ ONE-WAY CRYSTAL MARKER

RURAL LEFT TURN

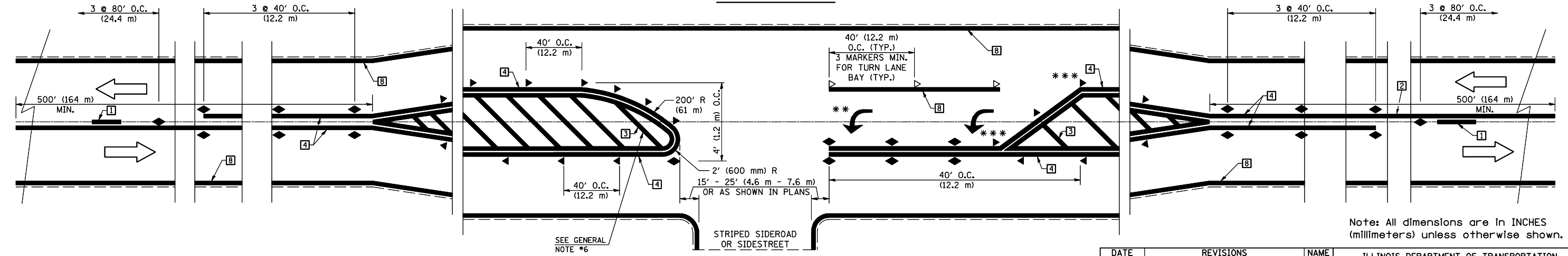

Note: All dimensions are in INCHES (millimeters) unless otherwise shown.

*** REDUCE SPACING IF NECESSARY TO ASSURE MARKERS AT CORNER POINTS.

** TURN ARROWS SHALL BE PLACED AS SHOWN ON SHEET #2.

DATE	REVISIONS	NAME
11/06	REPLACED DETAIL F-5.25	TJB

ILLINOIS DEPARTMENT OF TRANSPORTATION

PAVEMENT MARKING AND MARKERS (RURAL & URBAN APPLICATIONS)

DISTRICT 5 DETAIL NO. 7800AAAA

PLOT DATE = 8/21/2008
 FILE NAME = c:\p\projects\4591385 (v8)\7800AAAA.dgn
 PLOT SCALE = 1/8" = 1' / IN.
 USER NAME = sheehyjm

F.A.I. RTE.	SECTION	COUNTY	TOTAL SHEETS	SHEET NO.
57	*	DOUGLAS	76	74

* (15,21-25,21-26,27)RS-1

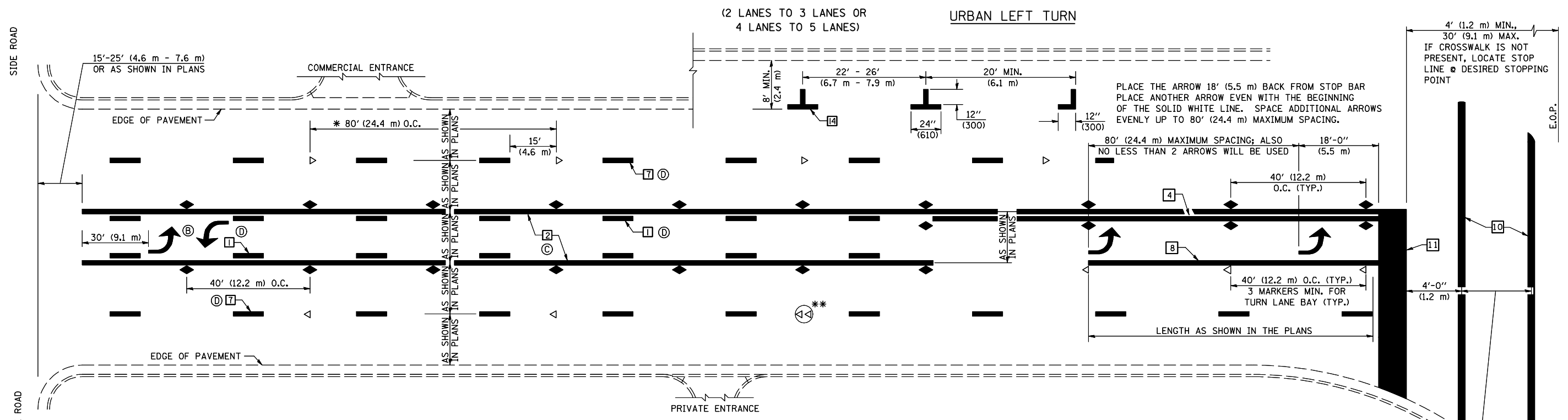

* REDUCE TO 40 FEET (12.2 METERS) ON CENTER ON CURVES WHERE ADVISORY SPEEDS ARE 10 MPH (15 km/h) LOWER THAN POSTED SPEEDS.

** DOUBLE LANE LINE MARKERS SHALL BE SPECIFIED AND SPACED AS SHOWN IN HIGHWAY STANDARD 781001 FOR MULTI-LANE DIVIDED AND UNDIVIDED HIGHWAYS.

BLOOMINGTON-NORMAL CITY LIMITS ONLY

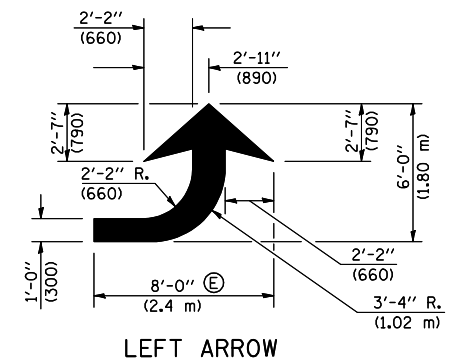

LEFT ARROW
REVERSE FOR RIGHT ARROW
AREA = 15.6 SQ. FT. (1.47 m²) (WHITE)

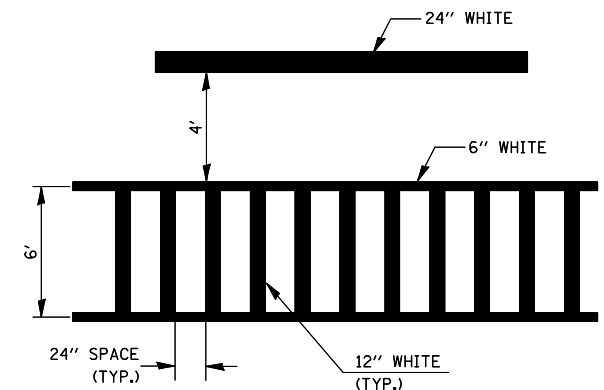

TYPICAL SPACING FOR CROSSWALKS & STOP BARS

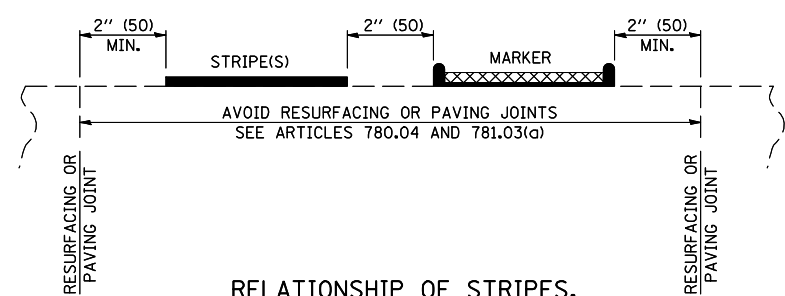

RELATIONSHIP OF STRIPES, MARKERS AND JOINTS

- GENERAL NOTES:**
- Ⓑ TURN ARROW PAIRS SHALL BE PLACED AT 250' (75 m) INTERVALS AND SHALL BE EVENLY SPACED BETWEEN BOTH ENDS OF THE BIDIRECTIONAL LEFT TURN LANE.
 - Ⓒ THE SOLID YELLOW PAVEMENT MARKINGS [2] SHOULD GENERALLY START OR END NEAR THE RADIUS POINT OF EACH STREET RETURN EXCEPT WHERE ONE OR BOTH ENDS WOULD INCLUDE STOP BARS.
 - Ⓓ THE SKIP-DASH PAVEMENT MARKINGS [1] OR [7] SHOULD BE CENTERED BETWEEN BOTH ENDS OF EACH CITY BLOCK AND SHALL BE PLACED SO THEY LINE UP ACROSS FROM EACH OTHER. SEE EXAMPLE ON SHEET 2 OF 3.
 - Ⓔ USE LARGE ARROW SIZE FOR BOTH RURAL AND URBAN LOCATIONS. (SEE LAST PAGE OF SECTION 780x FOR SYMBOLS TABLE)

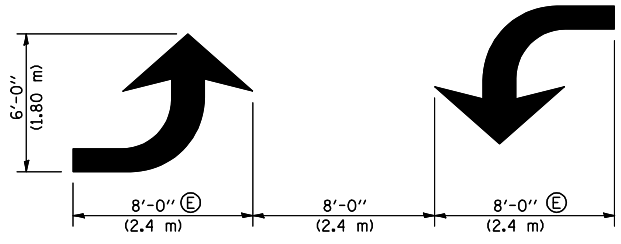

TYPICAL DOUBLE TURN ARROWS (WHITE)

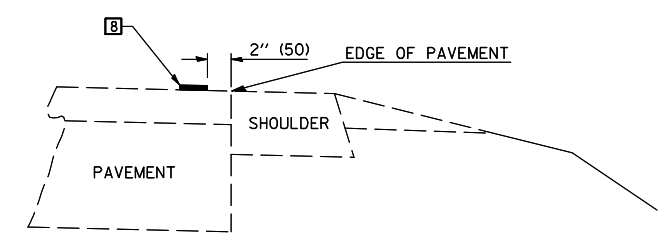

RELATIONSHIP OF EDGE LINE TO EDGE OF PAVEMENT
(SAFETY SHOULDER OR PAVED SURFACE)
SEE ARTICLE 780.04

Note: All dimensions are in INCHES (millimeters) unless otherwise shown.

DATE	REVISIONS	NAME
11/06	REPLACED DETAIL F-5.25	TJB

ILLINOIS DEPARTMENT OF TRANSPORTATION
PAVEMENT MARKING AND MARKERS (RURAL & URBAN APPLICATIONS)
DISTRICT 5 DETAIL NO. 7800AAA

PLOT DATE = 8/21/2008
FILE NAME = c:\p\projects\70465\70465detaila.dgn
PLOT SCALE = 1/8" = 1' / IN.
USER NAME = sheehyjm

F.A.I. RTE.	SECTION	COUNTY	TOTAL SHEETS	SHEET NO.
57	*	DOUGLAS	76	75

* (15,21-25,21-26,27)RS-1

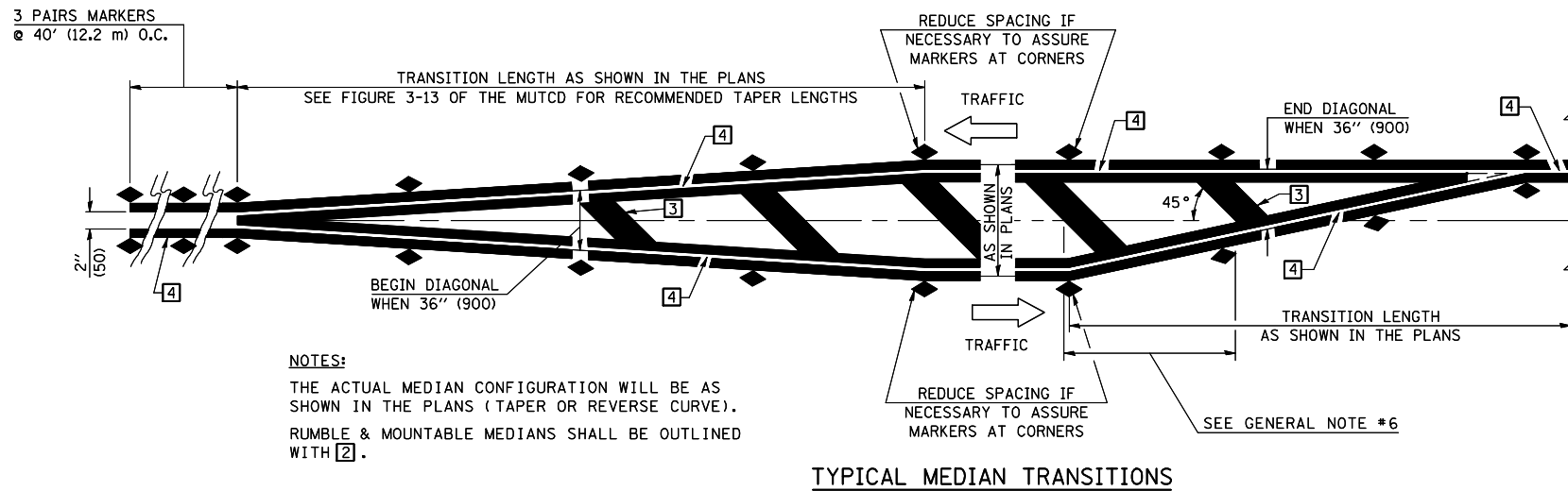

GENERAL NOTES

1. WHEN MEDIANS ARE PRESENT, PAVEMENT MARKINGS ARE TO BE PLACED ADJACENT TO MEDIANS.
2. SOME OF THE INFORMATION INCLUDED WITH THIS DETAIL MAY NOT BE APPLICABLE TO THIS IMPROVEMENT.
3. PAVEMENT MARKINGS ARE TO BE EXTENDED THROUGH OMISSIONS WHEN APPLICABLE.
4. A STRIPING KEY IS AVAILABLE ELSEWHERE AND SHALL BE SHOWN WHERE THE QUANTITIES ARE LISTED.
5. FINAL PAVEMENT MARKINGS SHALL BE IN PLACE PRIOR TO PLACING ANY RAISED REFLECTIVE PAVEMENT MARKERS.
6. THE FOLLOWING CRITERIA SHALL BE USED FOR SELECTING THE DIAGONAL PAVEMENT MARKING SPACING,
< 30 MPH USE 15' (< 50 km/h USE 4.5 m)
30-45 MPH USE 20' (50-75 km/h USE 6.0 m)
> 45 MPH USE 30' (> 75 km/h USE 9.0 m)

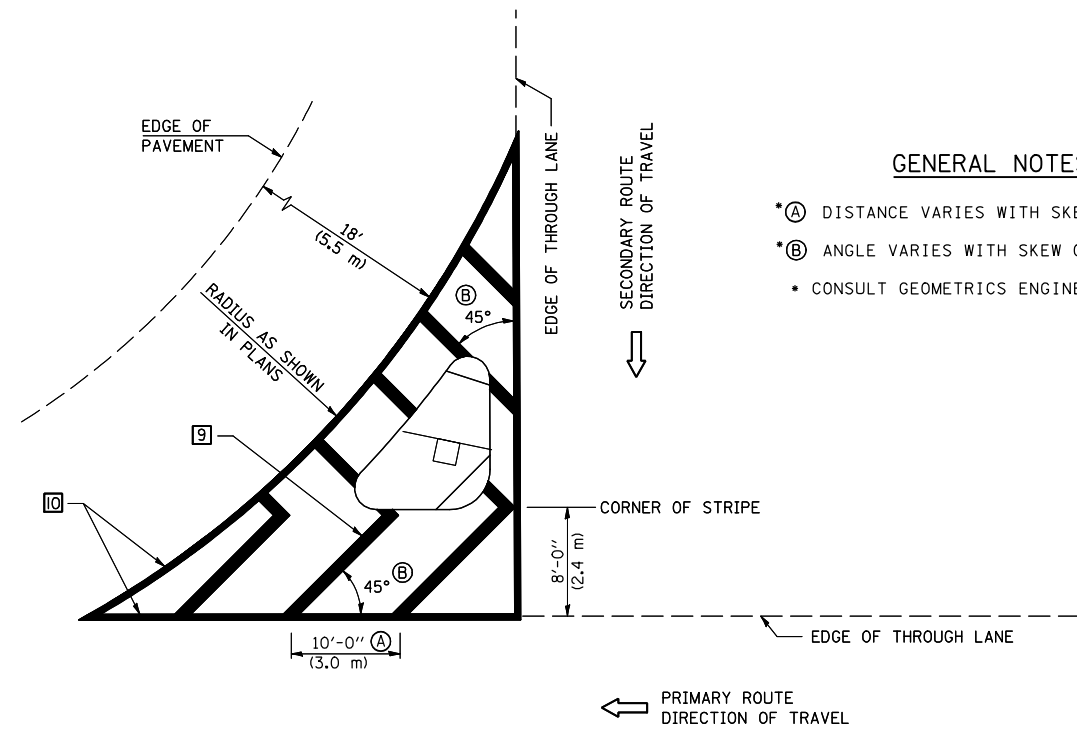
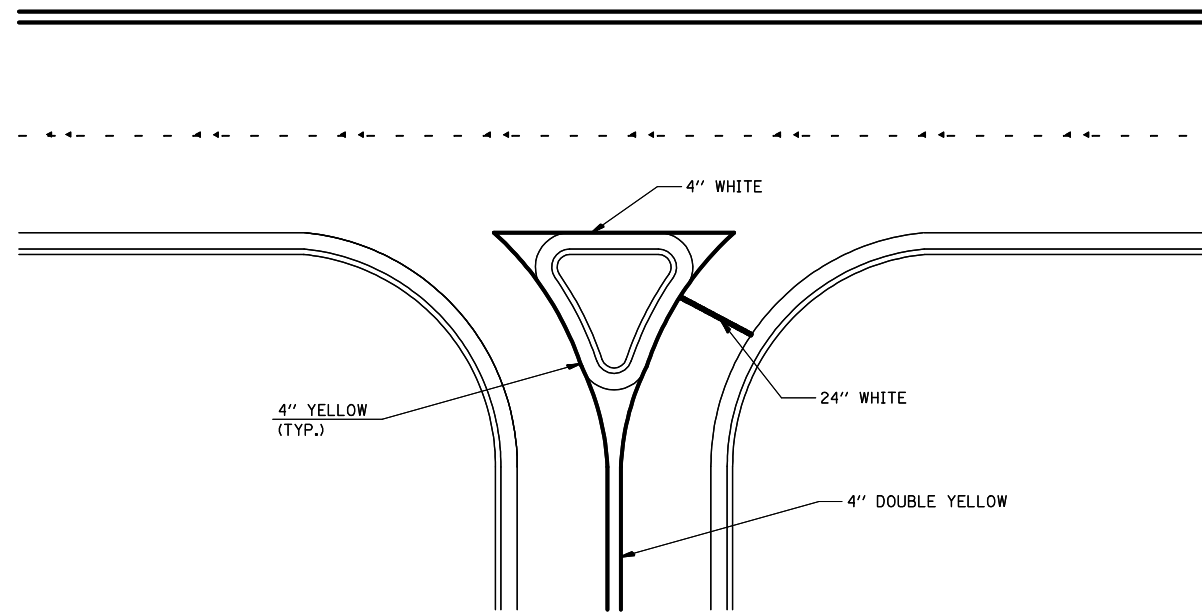

GENERAL NOTES

- * (A) DISTANCE VARIES WITH SKEW OF INTERSECTION.
- * (B) ANGLE VARIES WITH SKEW OF INTERSECTION.
- * CONSULT GEOMETRICS ENGINEER

Note: All dimensions are in INCHES (millimeters) unless otherwise shown.

DATE	REVISIONS	NAME
11/06	REPLACED DETAIL F-5.25	TJB

ILLINOIS DEPARTMENT OF TRANSPORTATION

PAVEMENT MARKING AND MARKERS (RURAL & URBAN APPLICATIONS)

DISTRICT 5 DETAIL NO. 7800AAAA

PLOT DATE = 8/21/2008
FILE NAME = c:\projects\45801385 (v8)\7800AAAA.dgn
PLOT SCALE = 1/8" = 1'-0" / IN.
USER NAME = sheehyjm

F.A.I. RTE.	SECTION	COUNTY	TOTAL SHEETS	SHEET NO.
57	*	DOUGLAS	76	76

*(15,21-25,21-26,27)RS-1

RAILROAD CROSSING WITH INTERCONNECT ONLY

RAILROAD CROSSING WITH INTERCONNECT AND PRE-SIGNALS

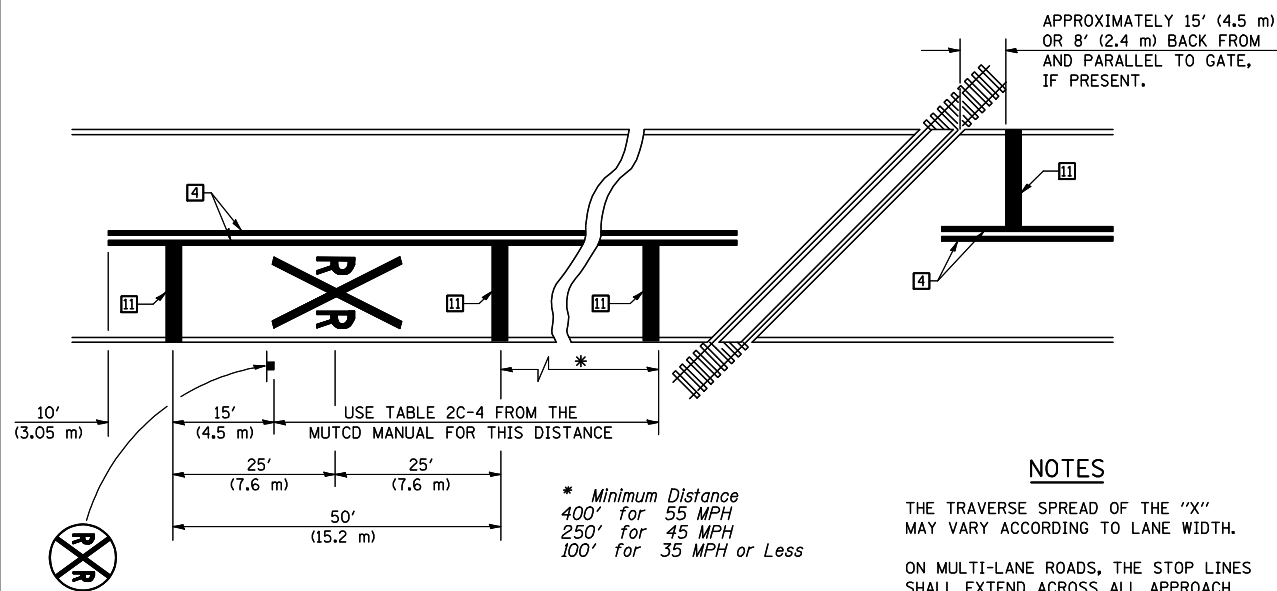

PAVEMENT MARKINGS AT RAILROAD-HIGHWAY GRADE CROSSING

NOTES

THE TRAVERSE SPREAD OF THE "X" MAY VARY ACCORDING TO LANE WIDTH.

ON MULTI-LANE ROADS, THE STOP LINES SHALL EXTEND ACROSS ALL APPROACH LANES AND SEPARATE RXR SYMBOLS SHALL BE PLACED ADJACENT TO EACH OTHER IN EACH LANE.

WHEN THE PAVEMENT MARKING SYMBOL IS USED, A PORTION OF THE SYMBOL SHOULD BE LOCATED DIRECTLY ADJACENT TO THE ADVANCE WARNING SIGN (W10-1) AS PLACED BY TABLE II-1, CONDITION B OF THE MUTCD.

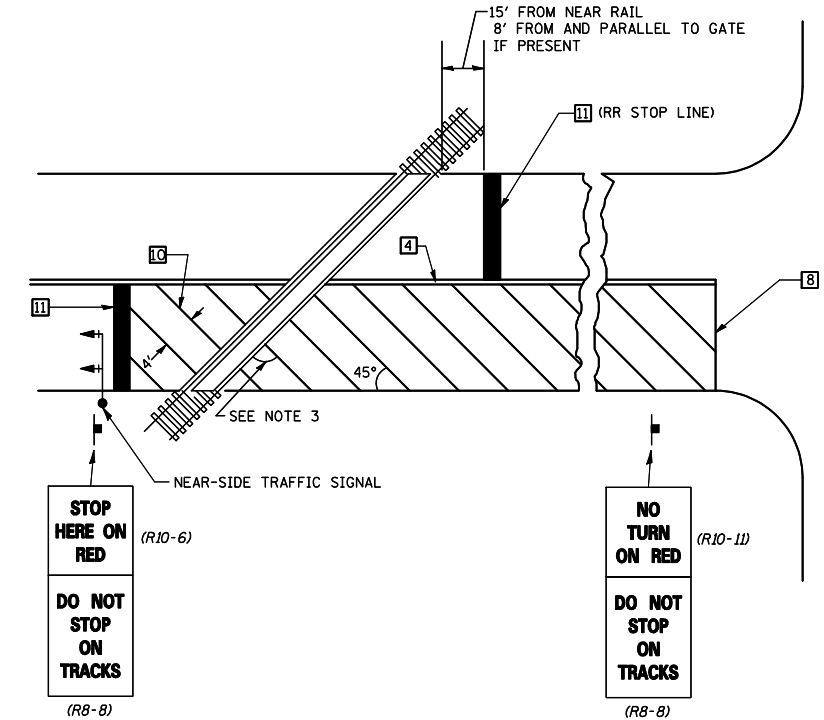
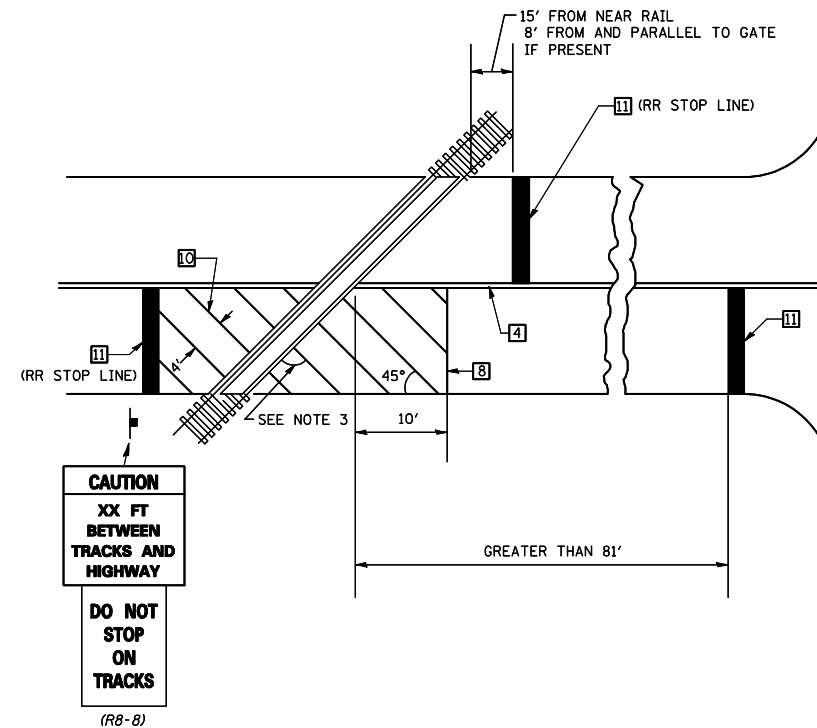

SUPPLEMENTAL PAVEMENT MARKING TREATMENT FOR RAILROAD-HIGHWAY GRADE CROSSING

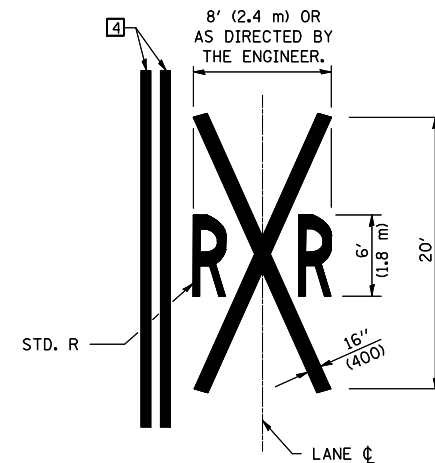

GENERAL NOTES

- SUPPLEMENTAL PAVEMENT MARKINGS TO BE INSTALLED ONLY ON APPROACHES TO INTERSECTIONS CONTROLLED BY TRAFFIC SIGNALS WHICH ARE INTERCONNECTED WITH THE RAILROAD WARNING SIGNALS.
- EXTEND PAVEMENT MARKINGS TO THE INTERSECTION ONLY WHERE NEAR-SIDE TRAFFIC SIGNALS ARE USED.
- WHERE THE ANGLE BETWEEN THE DIAGONAL PAVEMENT MARKINGS AND THE TRACK WOULD BE LESS THAN 20°, THE PAVEMENT MARKINGS SHOULD BE PLACED IN THE OPPOSITE DIRECTION FROM THAT SHOWN.

Note: All dimensions are in INCHES (millimeters) unless otherwise shown.

DATE	REVISIONS	NAME	ILLINOIS DEPARTMENT OF TRANSPORTATION
11/06	REPLACED DETAIL F-5.25	TJB	PAVEMENT MARKING AND MARKERS (RURAL & URBAN APPLICATIONS)
			DISTRICT 5 DETAIL NO. 7800AAAA

PLOT DATE = 8/21/2008
 FILE NAME = c:\projects\4591385 (v8)\70465detaila.dgn
 PLOT SCALE = 1/8"=1'-0"
 USER NAME = sheehyem