

F.A.S. RTE	SECTION	COUNTY	TOTAL SHEETS	SHEET NO
932	(6,9,11)W,RS-1	*	401	198
STA.	TO STA.			
FED. ROAD DIST. NO. -	ILLINOIS	FED. AID PROJECT		
* JOHNSON & POPE				

## TYPICAL SECTIONS OF TRANSITIONS OF SLOPES AND INCIDENTAL GRADING

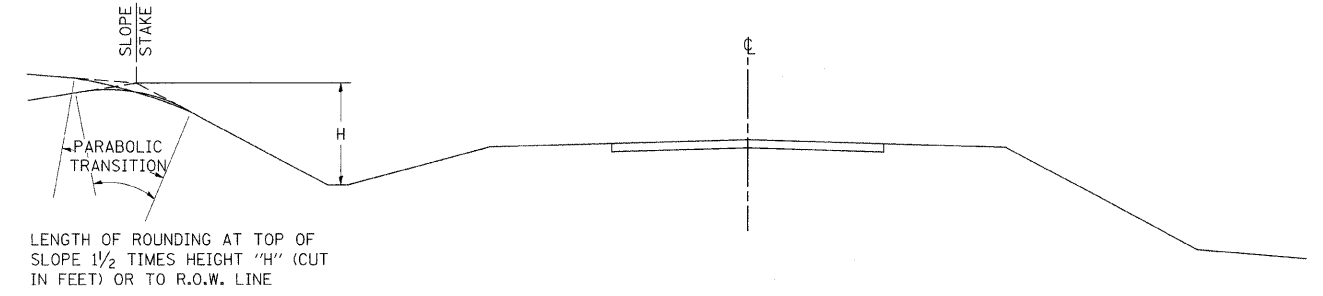

SECTION SHOWING TRANSITIONS OF PROPOSED SLOPES

**NOTE:**

DITCH PLUG TO BE CONSTRUCTED AS DIRECTED BY THE ENGINEER, INCLUDED IN THE EARTH EXCAVATION

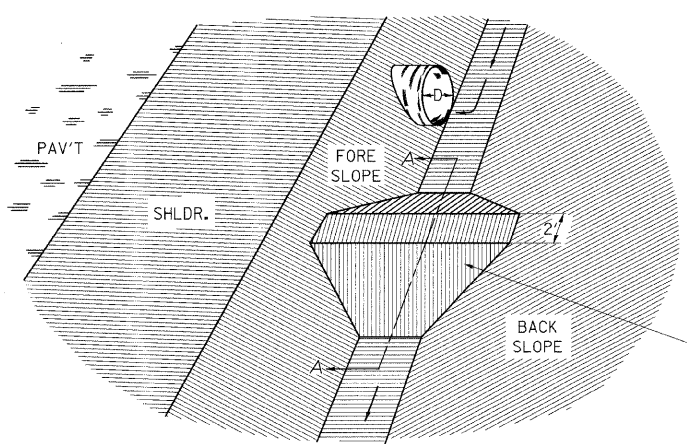

DITCH PLUG DETAIL

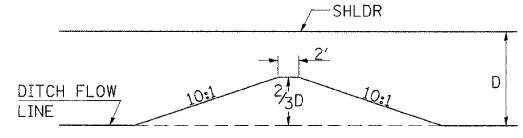

SECTION A-A

EARTH DITCH PLUG TO BE CONSTRUCTED AT LOCATIONS SHOWN ON THE PLANS OR AS DIRECTED BY THE ENGINEER, AND TO BE CONSIDERED INCLUDED IN THE EARTH EXCAVATION.

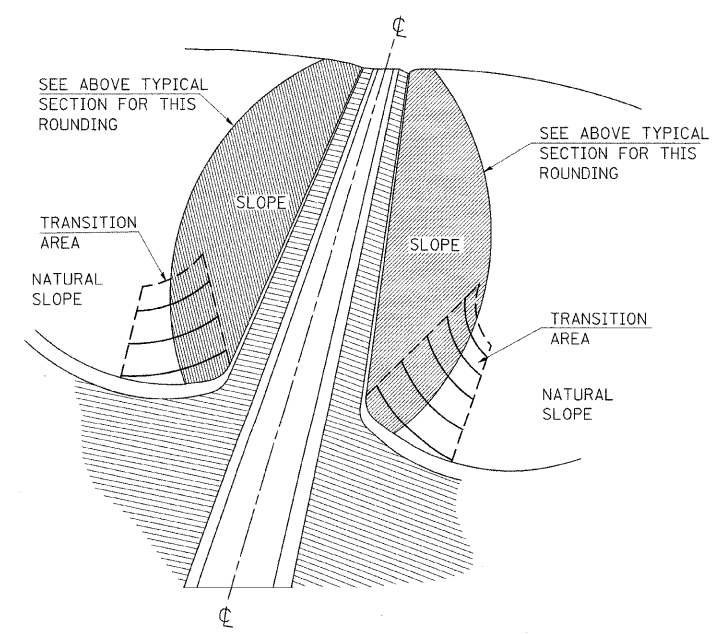

DETAIL OF SLOPE TO NATURAL GROUND TRANSITION

### TRANSITION GRADING

TRANSITION GRADING BETWEEN CUT AND FILL SLOPES AND BETWEEN CUT SLOPES AND NATURAL GROUND WILL BE REQUIRED ON THIS IMPROVEMENT. THE TRANSITION SHALL BE ROUNDED AND STREAMLINED IN ORDER TO BLEND THE CUT SLOPES AND THE FILL SLOPES INTO EACH OTHER AND INTO THE ADJACENT TERRAIN. THE SLOPES AS SHOWN ON THE CROSS SECTIONS IN THESE PLANS MAY BE VARIED SOMEWHAT IN THE TRANSITION AREAS AS DIRECTED BY THE ENGINEER IN ORDER TO MEET THIS GRADING REQUIREMENT. THE QUANTITIES OF EARTH EXCAVATION INVOLVED ARE INCLUDED IN THE BALANCE QUANTITIES SHOWN ON THE PLANS AND NO OTHER COMPENSATION WILL BE ALLOWED.

REVISIONS
REVISION 2-15-89
REVISION
REVISION
REVISION

STD. 9-17

\* VARIES 10'-12'

## BUTT JOINT

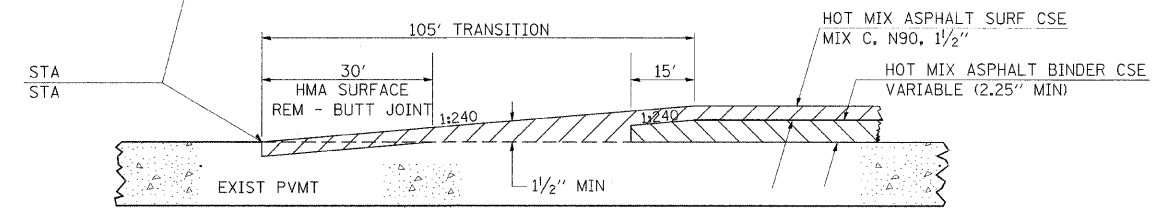
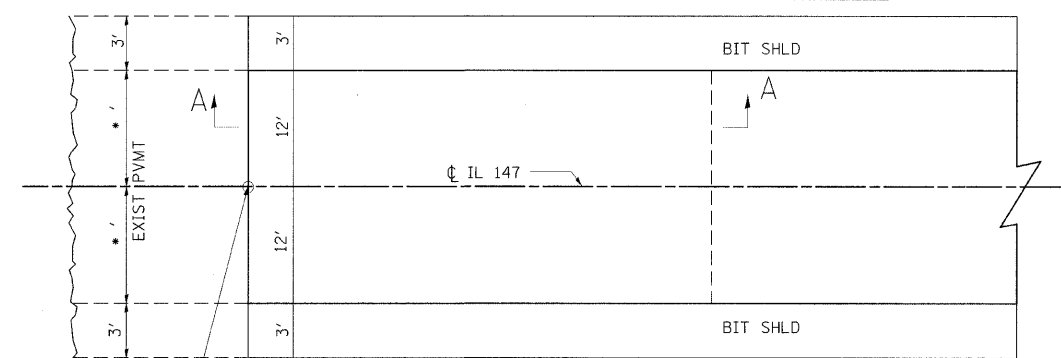

SECTION A-A

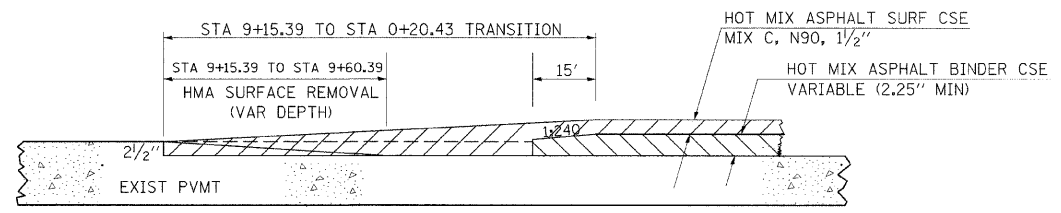

SECTION A-A USED STA 9+15.39 TO 0+20.43

REVISIONS
REVISION 10-17-90
REVISION
REVISION

STD. 9-86

## TEMPORARY HOT-MIX ASPHALT TRANSITIONS

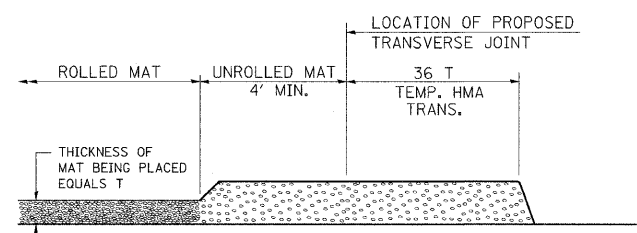

### STEP I

1. PLACE HOT-MIX ASPHALT MAT, LENGTH 36 TIMES THE THICKNESS OF THE MAT BEING PLACED PAST THE PROPOSED TRANSVERSE JOINT LOCATION USING NORMAL OPERATING PROCEDURES.
2. EXTREME CARE SHOULD BE TAKEN TO MAINTAIN ENOUGH MATERIAL IN FRONT OF THE SCREED TO MAINTAIN REQUIRED PAVING DEPTH.

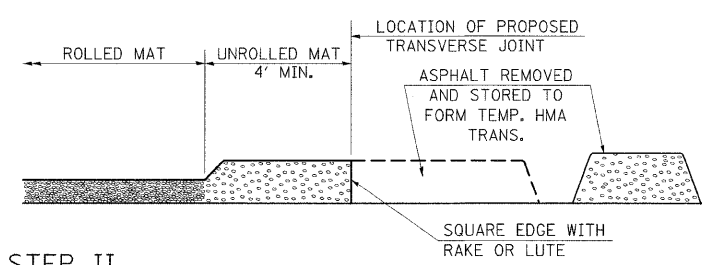

### STEP II

1. MOVE THE PAVER OUT OF THE WAY AND REMOVE THE ASPHALT FROM THE AREA OF THE PROPOSED TEMPORARY HOT-MIX ASPHALT TRANSITION.
2. SQUARE UP THE END OF THE MAT WITH A RAKE OR LUTE.
3. NOTE THAT THE MAT WITHIN 4' OF THE END OF JOINT IS NOT TO BE ROLLED AT THIS TIME.

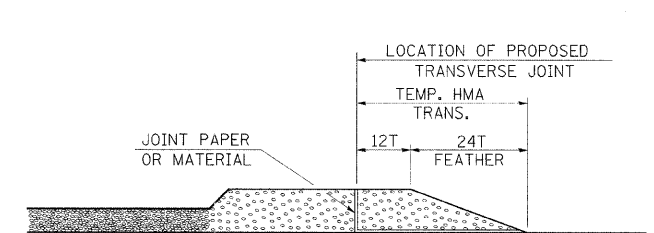

### STEP III

1. JOINT PAPER OR OTHER PRESELECTED JOINT MATERIAL IS THEN PLACED IN THE CLEARED AREA AND THE EXCESS ASPHALT USED TO HAND FORM A TRANSITION TO THE DIMENSIONS SHOWN ABOVE.
2. NOTE THAT IN CONSTRUCTING THE TRANSITION, THE MAT DEPTH IS CONTINUED AS PART OF THE TRANSITION BEFORE FORMING THE FEATHER.

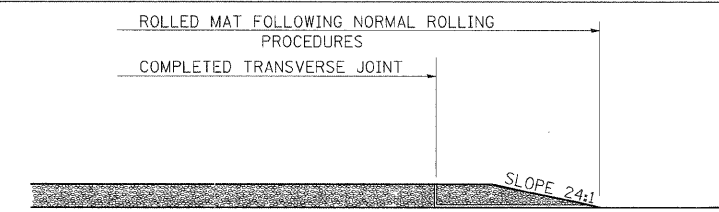

### STEP IV

1. COMPLETE TEMPORARY TRANSITION BY ROLLING.
2. TO RESUME PAVING, AT THE JOINT, REMOVE TEMPORARY TRANSITION AND DISPOSE OF THE MATERIAL ACCORDING TO ART. 202.03 OF THE STD. SPECS. (COST INCLUDED IN THE CONTRACT).
3. CONSTRUCTING THE TEMPORARY TRANSITIONS WILL NOT BE PAID FOR SEPARATELY IN ACCORDANCE WITH ARTICLE 406.14 OF THE STANDARD SPECIFICATIONS.

REVISIONS
REVISION 2-15-89
REVISION 8-16-94
REVISION 01-09-07

STD. 9-26

## DETAILS: TRANSITION OF SLOPES AND INCIDENTAL GRADING, BUTT JOINT TEMPORARY HOT-MIX ASPHALT TRANSITIONS