

* Dimensions vary per location.
 ** Some interior panels are not 20' long.

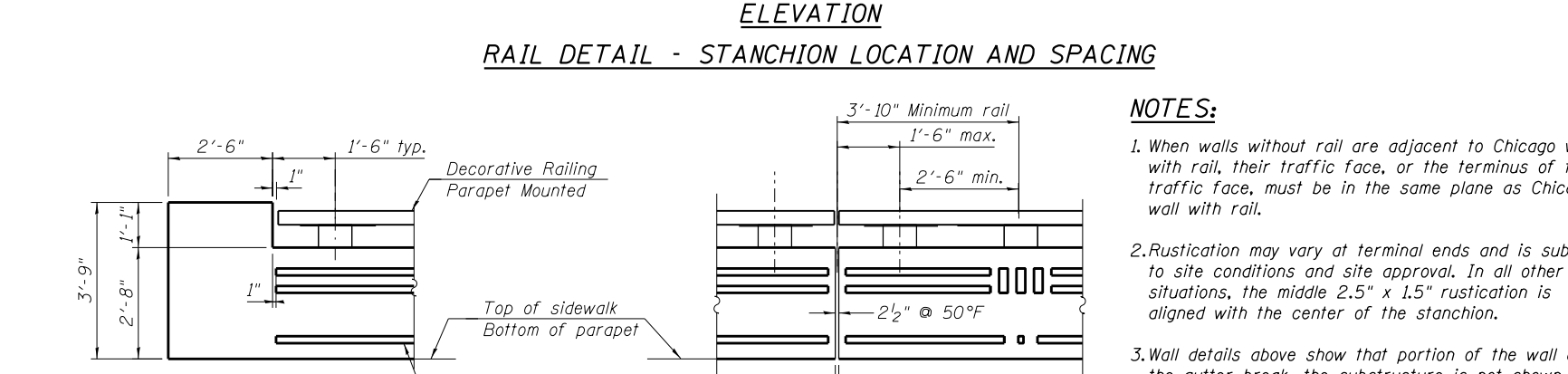

- NOTES:**
- When walls without rail are adjacent to Chicago wall with rail, their traffic face, or the terminus of their traffic face, must be in the same plane as Chicago wall with rail.
 - Rustication may vary at terminal ends and is subject to site conditions and site approval. In all other situations, the middle 2.5" x 1.5" rustication is aligned with the center of the stanchion.
 - Wall details above show that portion of the wall above the gutter break, the substructure is not shown. Note that substructure(s) depth variations could significantly alter the required top of wall profile.
 - Field cutting of rail elements is acceptable. The cut edge will no longer be anodized. Saw cut only, flame cut not allowed.
 - End caps shall be used at all rail terminals.
 - Railing system to be produced using extruded aluminum that can be clear anodized.
 - Alloy selection is based upon the above color requirement and the engineering sufficiency analysis which must be supplied by the contractor.
 - The reveal on the bridge parapet Chicago wall will not be paid separately and shall be included in the cost of the pay item "Concrete Superstructure". Shop drawings shall be submitted including layout of the Chicago wall pattern, Chicago rail and light poles.

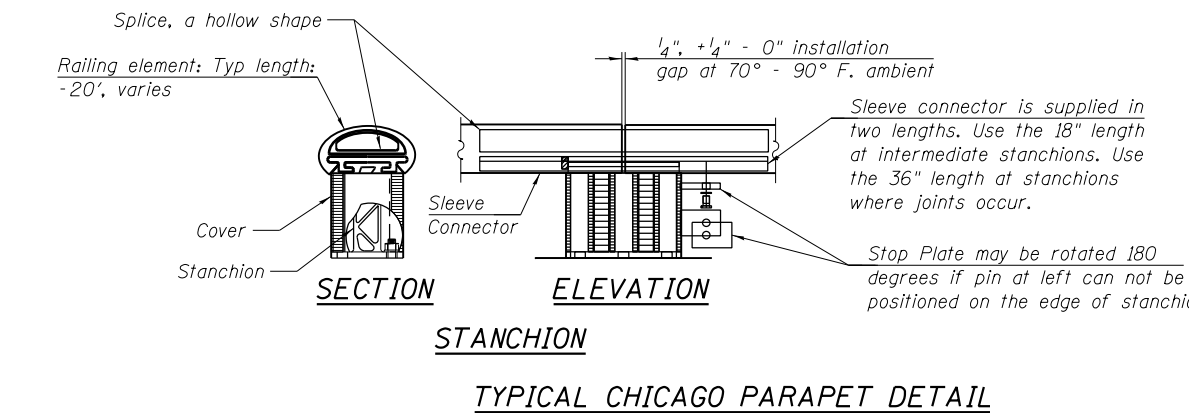
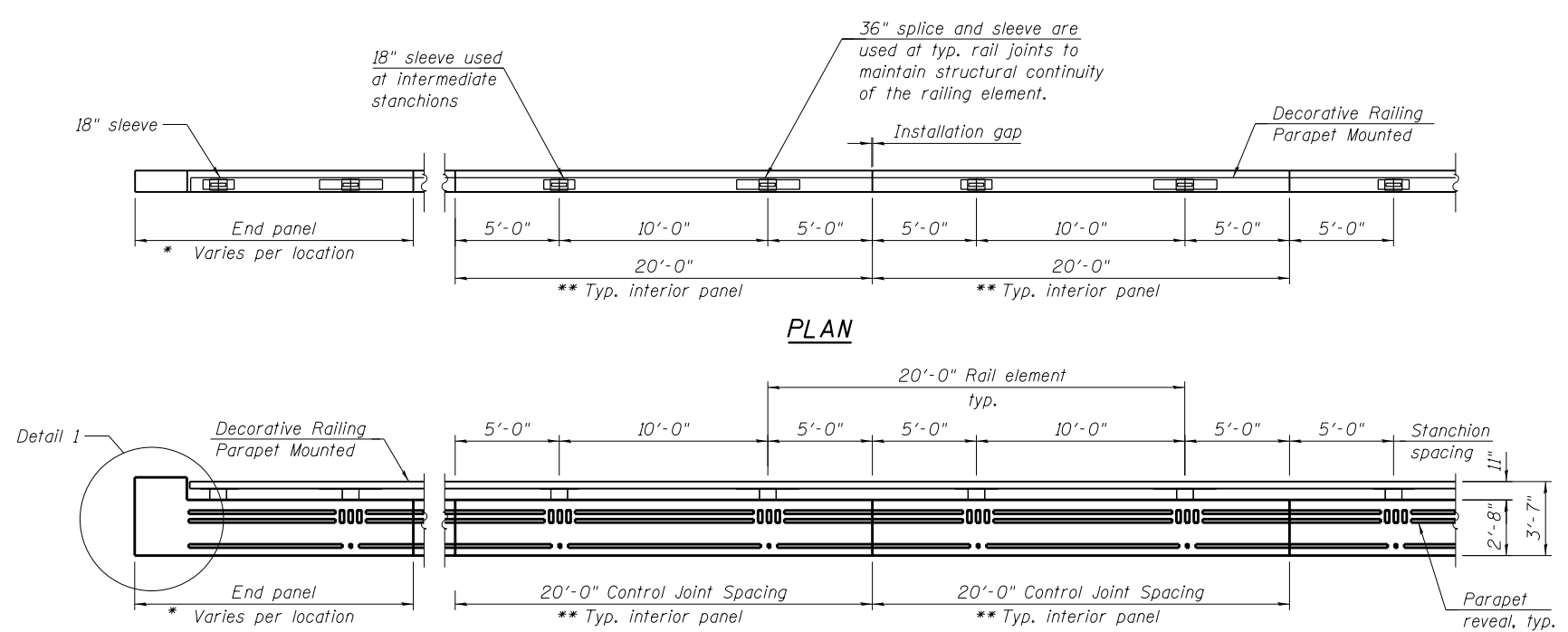
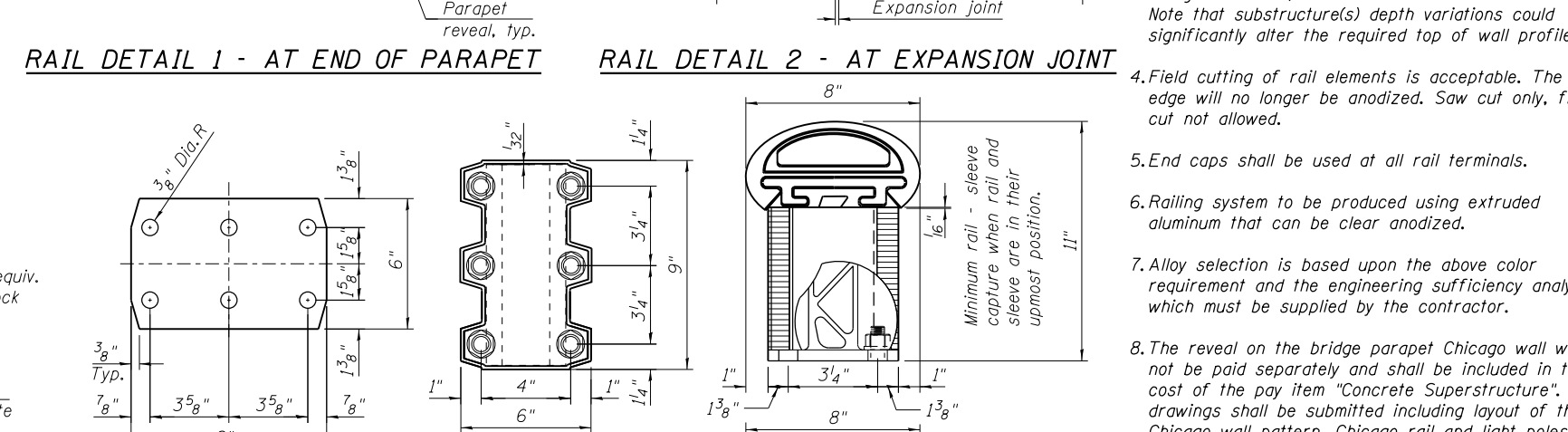
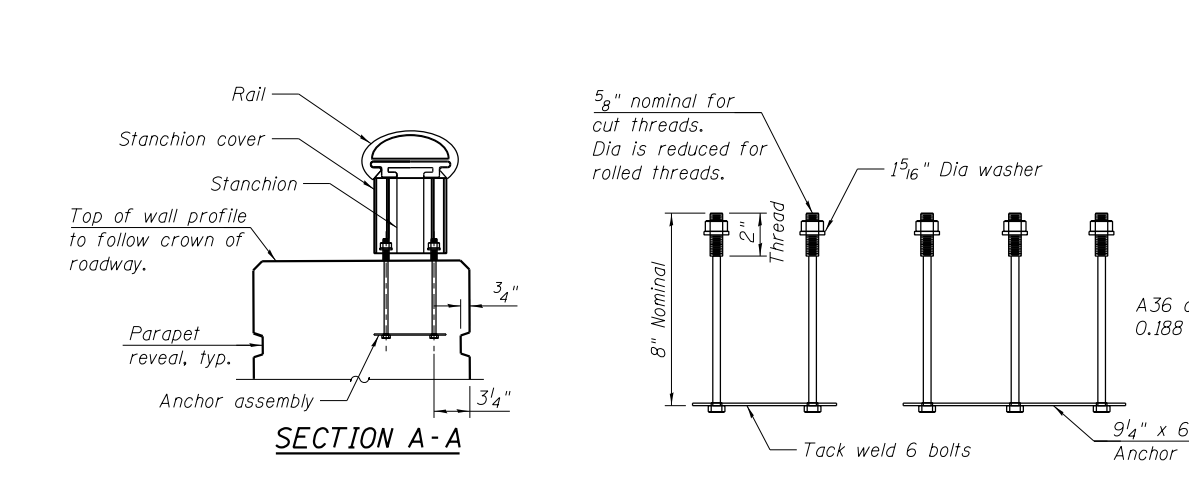

- ANCHOR ASSEMBLY NOTES:**
- All fasteners to meet, or exceed, A-307 strength requirements.
 - Galvanize per A-153 after fabrication.
 - The size and position of parapet reinforcing must be consistent with capture of the anchor assembly. See structural drawings for rebar details.

- ELASTOMERIC PAD NOTES:**
- Elastomeric pad for stanchion made from 1/16" thick stock.
 - One required per stanchion.

- STANCHION COVER NOTES:**
- Cover is shown superimposed over stanchion with anchors in place.
 - The stanchion cover is a non-structural element, serving an aesthetic function. It rests on the flange of the stanchion, without fasteners and is captured in place by the rail and stanchion.

BILL OF MATERIAL

Item	Unit	Quantity
Decorative Railing (Parapet Mounted)	Foot	620

0161713-60W26-S21-Parapet