

BUTT JOINT DETAIL

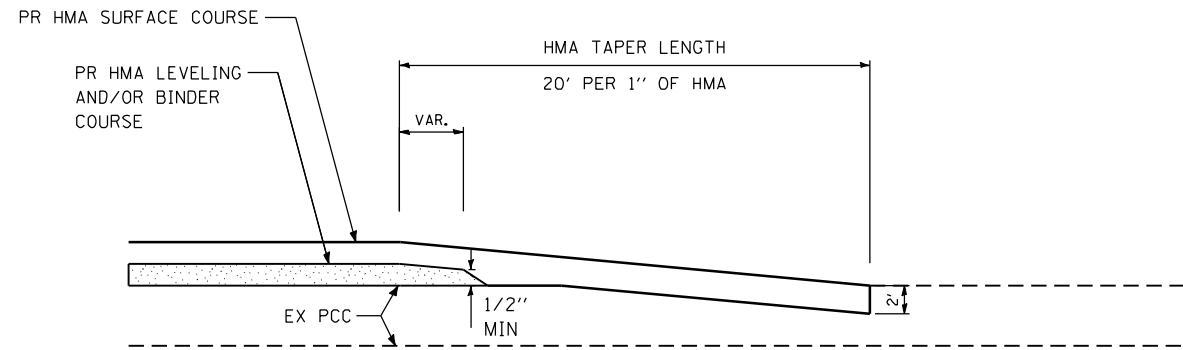

PCC SURFACE REMOVAL - BUTT JOINT DETAIL

NTS

NOTES:

1. THE SURFACE COURSE SHALL BE COMPLETED IMMEDIATELY UPON REMOVAL OF EXISTING PCC SURFACE IF THE ROADWAY IS OPEN TO TRAFFIC.
2. THE BUTT JOINT WILL BE PAID FOR AT THE CONTRACT UNIT PRICE PER SQUARE YARD FOR "PORTLAND CEMENT CONCRETE SURFACE REMOVAL - BUTT JOINT".

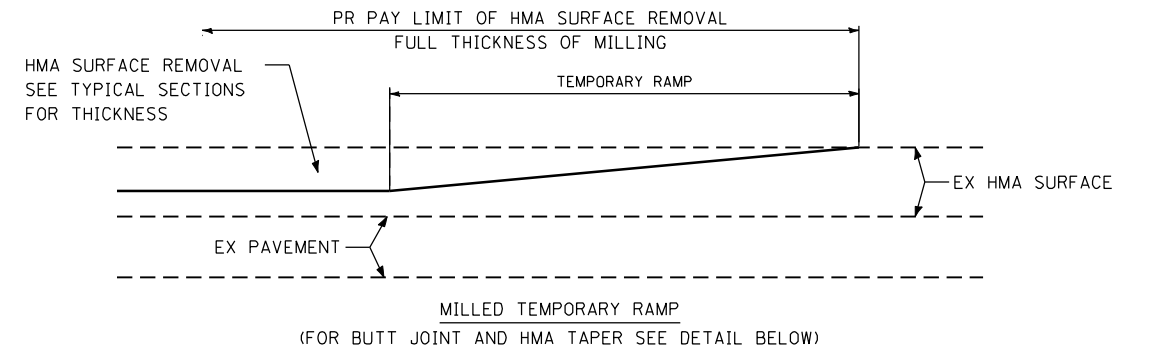

OPTION 1

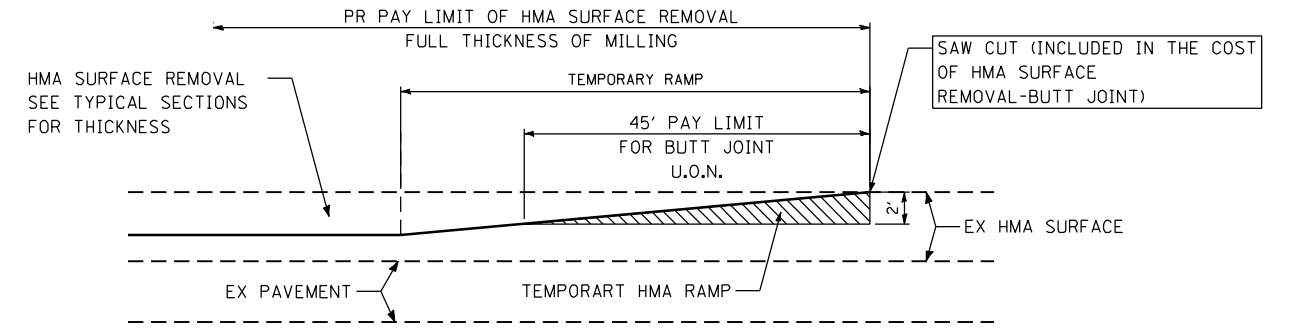

OPTION 2

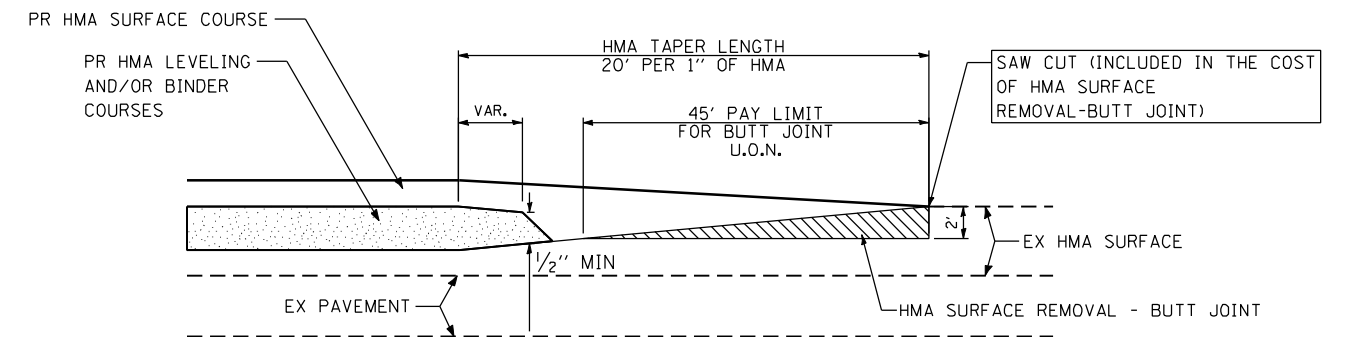

TYPICAL BUTT JOINT AND HMA TAPER FOR MILLING AND RESURFACING

NOTES:

1. THE TEMPORARY RAMP SHALL BE CONSTRUCTED IMMEDIATELY UPON REMOVAL OF THE EXISTING HMA SURFACE.
2. THE BUTT JOINT SHALL BE CONSTRUCTED IMMEDIATELY PRIOR TO PLACING THE PROPOSED HMA COURSES.
3. TEMPORARY RAMP LENGTH = 40 X SURFACE REMOVAL THICKNESS.
4. SEE ARTICLE 406.08 AND 406.14 OF THE STANDARDS SPECIFICATIONS FOR "HMA SURFACE REMOVAL, BUTT JOINT".
5. THE BUTT JOINT WILL BE PAID FOR AT THE CONTRACT UNIT PRICE PER SQUARE YARD FOR "HOT-MIX ASPHALT SURFACE REMOVAL - BUTT JOINT".

HMA SURFACE REMOVAL - BUTT JOINT DETAIL

NTS

FILE NAME: c:\p\proj\080319\08\contract\1\design\misc\sheet\0264884-ant-Details1.dgn

USER NAME = espino	DESIGNED - JAS	REVISED -
PLOT SCALE = 266.000532' / IN.	DRAWN - AMD	REVISED -
PLOT DATE = 3/11/2013	CHECKED - DMM	REVISED -
	DATE - 3/11/2013	REVISED -

F.A.P. RTE.	SECTION	COUNTY	TOTAL SHEETS	SHEET NO.
595	(142-1)R & 142-1)B	ROCK ISLAND	507	364
CONTRACT NO. 64B84				