

DETAILS OF PLANTING AND BRACING TREES

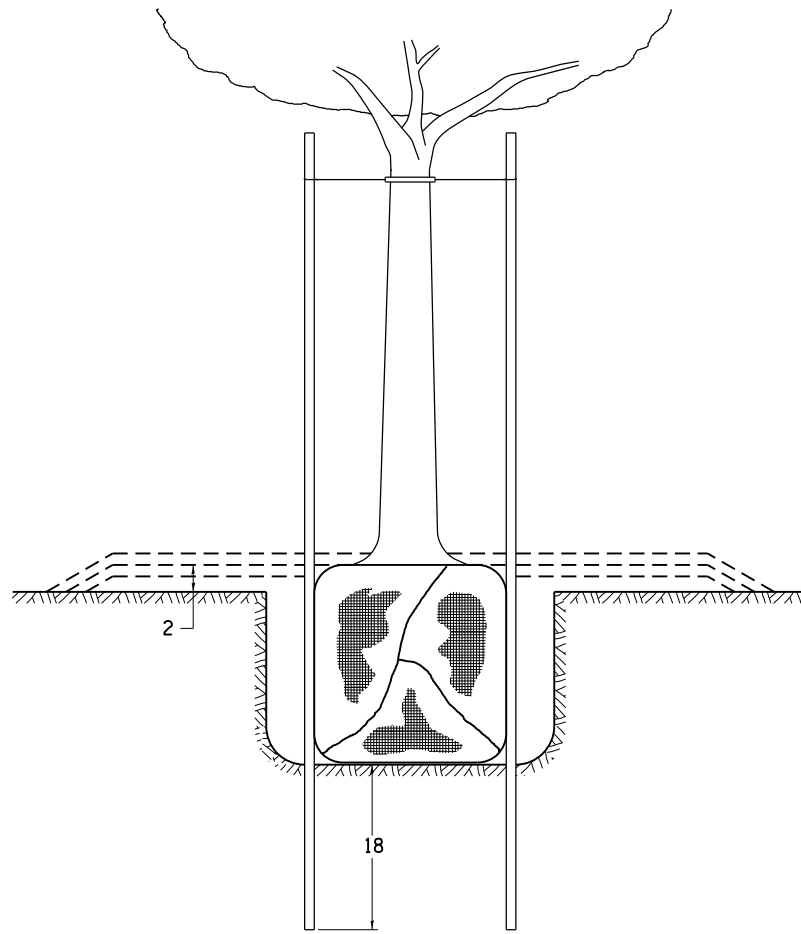

TREES SMALLER THAN 4 1/2 IN DIAMETER

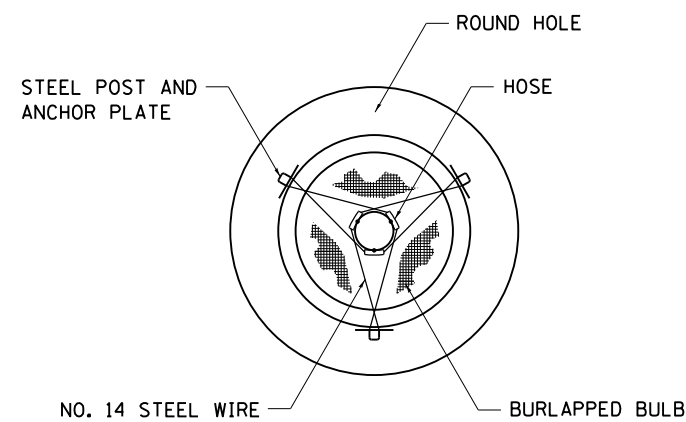

SMALL	A	B	C	D	E	F
TREE SIZE	DIAMETER OF BALL OR ROOT SYS.	DEPTH OF HOLE EXCAVATION	WIDTH OF HOLE EXCAVATION	THICKNESS OF MULCH COVER	DEPTH OF BALL OR ROOT SYS.	VOLUME OF MULCH COVER CU. YDS.
5'-6'	16	10	30	4	12	0.54
5'-6' BB	16	10	30	4	12	0.54
6'-7' BB	18	12	30	4	14	0.54
7'-8' BB	20	11	30	4	13	0.54
8'-10' BB	24	14	36	4	16	0.61
10'-12' BB	26	15	36	4	17	0.61

LARGE	A	B	C	D	E	F
TREE SIZE	DIAMETER OF BALL OR ROOT SYS.	DEPTH OF HOLE EXCAVATION	WIDTH OF HOLE EXCAVATION	THICKNESS OF MULCH COVER	DEPTH OF BALL OR ROOT SYS.	VOLUME OF MULCH COVER CU. YDS.
0-2	20	11	36	4	13	0.61
2-2 1/2 BB	24	14	48	4	16	0.78
2 1/2-3 BB	28	17	48	4	19	0.78
3-3 1/2 BB	32	17	60	4	19	0.96
3 1/2-4 BB	36	20	60	4	22	0.96
4-4 1/2 BB	40	22	72	4	24	1.16
4 1/2-5 BB	44	24	72	4	26	1.16
5-5 1/2 BB	48	27	84	4	29	1.38

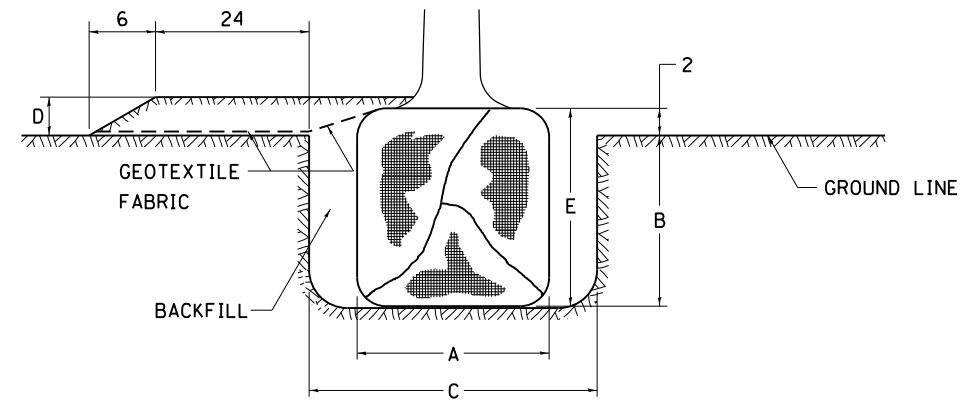

TREES OVER 4 1/2 IN DIAMETER

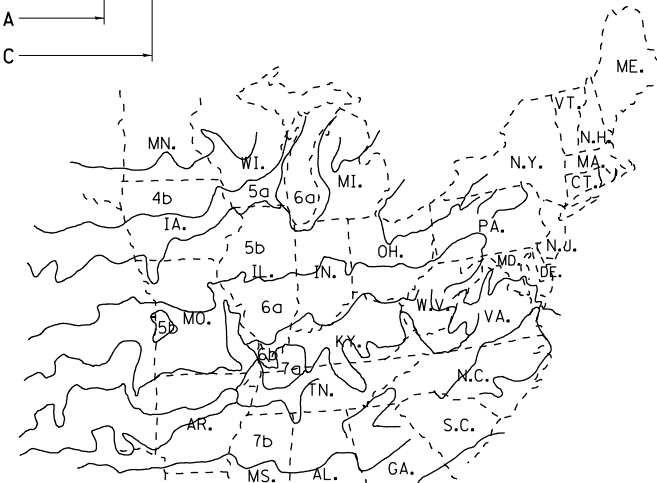

PLANT HARDINESS ZONE MAP

U.S. DEPARTMENT OF AGRICULTURE
AGRICULTURAL RESEARCH SERVICE
PUBLICATION NO. 814

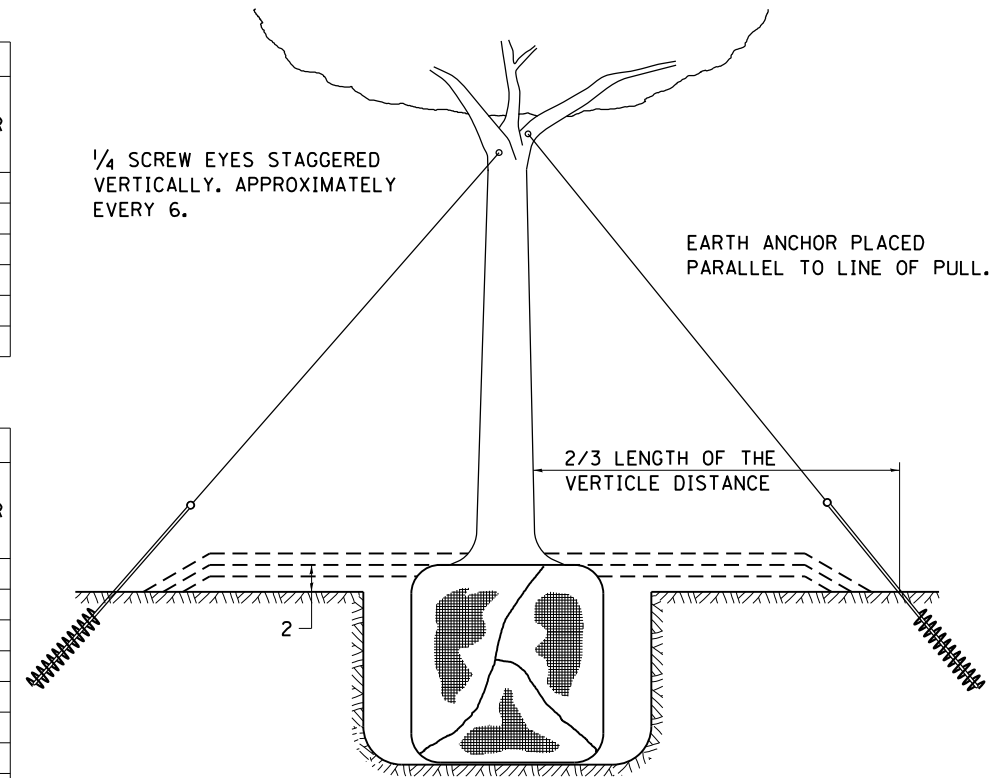

1/4 SCREW EYES STAGGERED VERTICALLY. APPROXIMATELY EVERY 6.

EARTH ANCHOR PLACED PARALLEL TO LINE OF PULL.

2/3 LENGTH OF THE VERTICLE DISTANCE

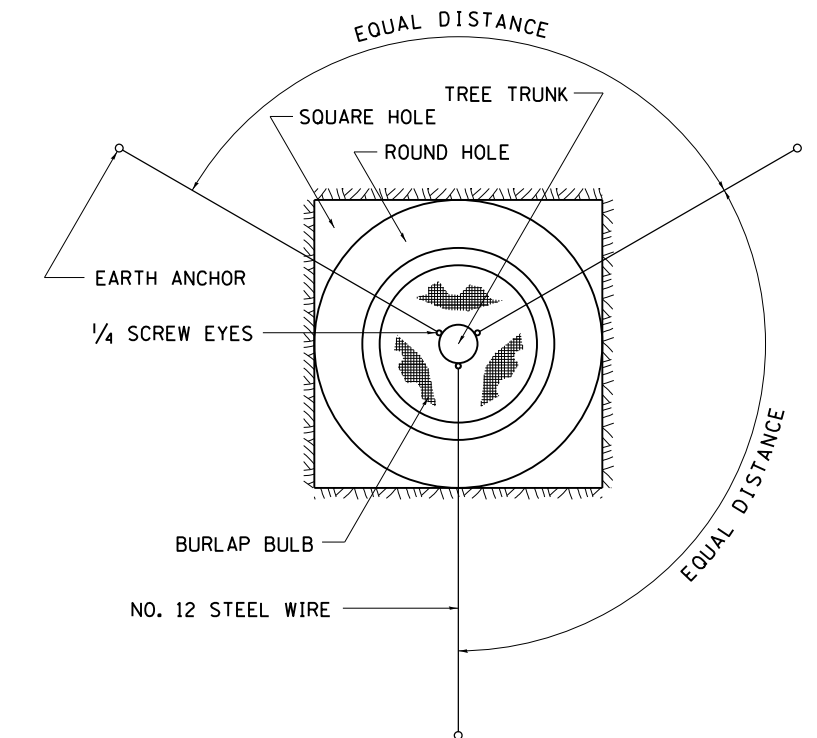

EARTH ANCHOR

1/4 SCREW EYES

BURLAP BULB

NO. 12 STEEL WIRE

ALL DIMENSIONS ARE IN INCHES UNLESS OTHERWISE NOTED.

DETAILS OF PLANTING AND BRACING TREES

92.1

FILE NAME = D264019-ah-t-D2-Details.dgn
MODEL = Default
PLOT DRIVER = V8...IDOT...PDF...11x17...plc1g



USER NAME = rgoertz	DESIGNED -	REVISED - 10-18-11
PLOT SCALE = 48.0000' / in.	DRAWN -	REVISED -
PLOT DATE = 8/16/2013	CHECKED - CMS	REVISED -
	DATE - 07/01/2013	REVISED -

STATE OF ILLINOIS
DEPARTMENT OF TRANSPORTATION

REGION 2 / DISTRICT 2 STANDARD

SCALE: SHEET NO. OF SHEETS STA. TO STA.

F.A.P. RTE.	SECTION	COUNTY	TOTAL SHEETS	SHEET NO.
301	3BR & 3BR-1	WINNEBAGO	290	261
CONTRACT NO. 64D19				
FED. ROAD DIST. NO. ILLINOIS FED. AID PROJECT				