

SECTION B-B

Note A:
The quantities and reinforcement detailing are based on the estimated top of rock elevations shown and may change based on the actual elevations encountered at each shaft.

* 3/4" φ x 8" Granular or solid flux filled headed studs conforming to Art. 1006.32 of the Std. Specifications automatically end welded at 12" cts. along each angle leg with 6" alternate centers from leg to leg. Cost shall be included with Furnishing and Erecting Structural Steel.

** L8 x 8 x 1/2 AASHTO M270 Gr. 50 galvanized in accordance with AASHTO M111. Cost included with Furnishing and Erecting Structural Steel.

Note:
The compressive strength of the concrete in the drilled shafts shall be 4,000 psi. min. at 14 days.

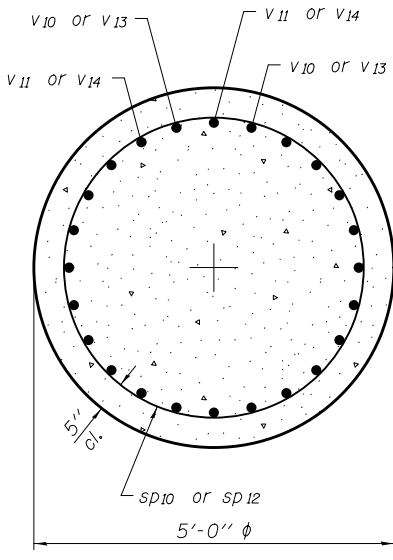

SECTION C-C

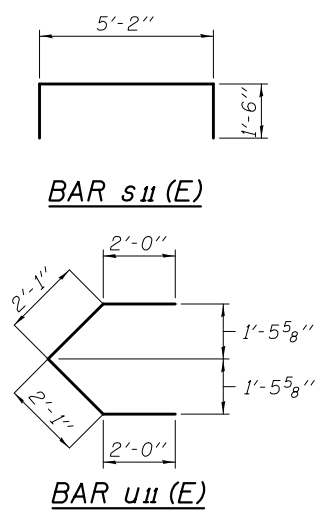

Note:
If the prevailing water surface elevation during construction is consistently different than estimated on the plans, the Contractor may propose an adjustment to the top of the permanent casing elevation as part of their installation procedure. The top of all permanent casings within a substructure unit shall be constructed to the same elevation and extend above the prevailing water surface. The quantity shown for permanent casing is based on the top of the casing being 1' above the E.W.S.E. and may change, as noted, subject to approval of the installation procedure.

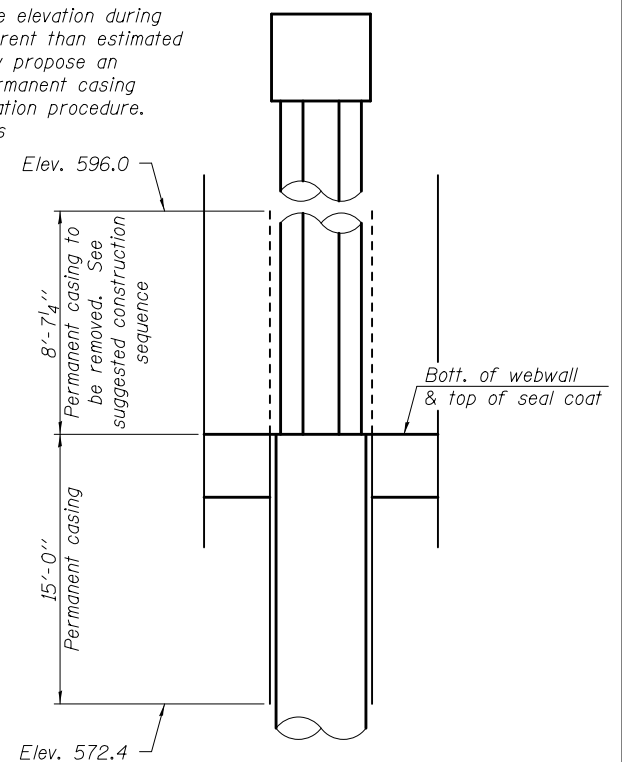

PERMANENT CASING DETAIL

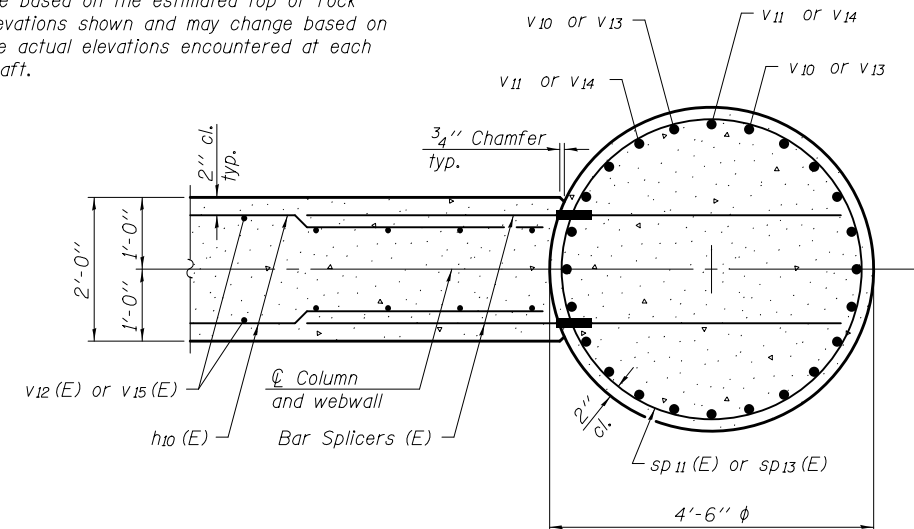

SECTION D-D

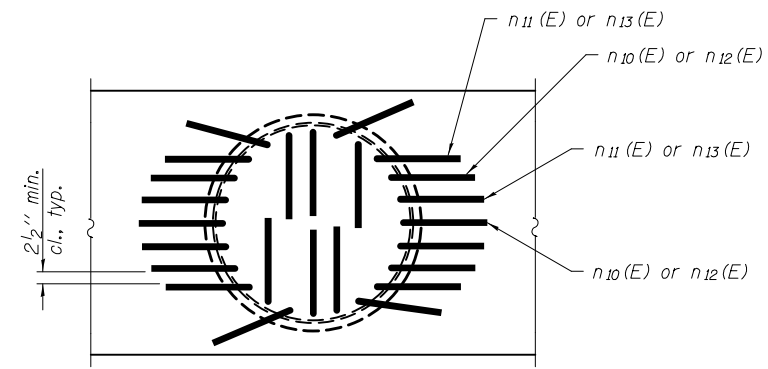

DETAIL A

Plan view of partial cap showing possible hook orientation of n10(E) thru n13(E).

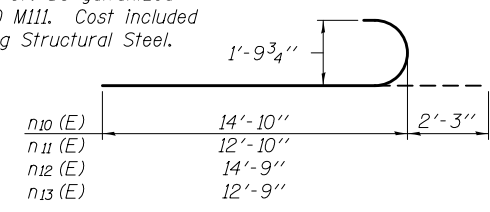

BARS n10(E) THRU n13(E)

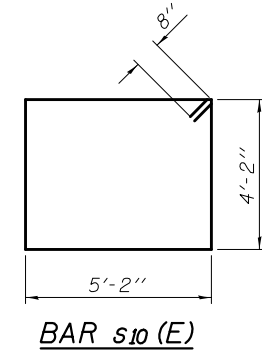

BAR s10(E)

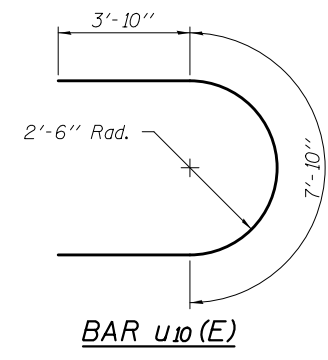

BAR u10(E)

SUGGESTED CONSTRUCTION SEQUENCE

- Cofferdam can be placed before permanent casings have been set or after shafts have been poured.
- Set permanent casing in soil (thru water) to 15 ft below the elevation of the bottom of the web wall. The permanent casing should extend to 1 ft above EWSE.
- Drill out soil and rock socket (thru casing).
- Clean shaft excavation and set shaft rebar.
- Pour concrete in shafts to an elevation some distance above bottom of web wall and:
 - Option A: Immediately remove all water and tainted concrete in the shaft down to the elevation of the bottom of web wall.
 - Option B: Leave excess shaft concrete in place until it can be removed in a later step.
- Cofferdam needs to be in place or be placed at this time, then excavate for and pour sealcoat to bottom of web wall.
- Dewater the cofferdam.
- Burn off permanent casing down to elevation of bottom of web wall/top of seal coat. If Option B has been followed, then also chip away the over poured concrete in the shaft to the elevation of the bottom of web wall/top of seal coat.
- Set up column reinforcement with inserts (for web walls).
- Pour concrete for columns.
- Construct webwalls.
- Construct cap.

PIER 1 - 046-0135 (N.B.) BILL OF MATERIAL

Bar	No.	Size	Length	Shape
h10(E)	90	#5	10'-2"	—
n10(E)	48	#14	17'-1"	U
n11(E)	48	#14	15'-1"	U
p10(E)	28	#8	27'-10"	—
p11(E)	16	#9	28'-10"	—
s10(E)	42	#6	20'-0"	□
*** SP10	4	#5	48'-11"	W
*** SP11(E)	4	#5	14'-7"	W
u10(E)	10	#6	15'-6"	U
u11(E)	15	#5	8'-2"	C
v10	48	#14	51'-9"	—
v11	48	#14	53'-9"	—
v12(E)	71	#5	14'-0"	—
Cofferdam Excavation	Cu. Yd.	104.3		
Cofferdam (Type 2) (Location 1)	Each	1		
Concrete Structures	Cu. Yd.	117.8		
Seal Coat Concrete	Cu. Yd.	76.0		
Reinforcement Bars	Pound	44,230		
Reinforcement Bars, Epoxy Coated	Pound	21,650		
Permanent Casing	Foot	94.4		
Drilled Shaft in Soil	Cu. Yd.	113.1		
Drilled Shaft in Rock	Cu. Yd.	23.6		

PIER 1 - 046-0136 (S.B.) BILL OF MATERIAL

Bar	No.	Size	Length	Shape
h10(E)	90	#5	10'-2"	—
h11(E)	5	#4	8'-6"	—
n12(E)	48	#14	17'-0"	U
n13(E)	48	#14	15'-0"	U
p10(E)	28	#8	27'-10"	—
p11(E)	16	#9	28'-10"	—
s10(E)	42	#6	20'-0"	□
s11(E)	9	#4	8'-2"	□
*** SP12	4	#5	47'-5"	W
*** SP13(E)	4	#5	14'-6"	W
u10(E)	10	#6	15'-6"	U
u11(E)	15	#5	8'-2"	C
v13	48	#14	50'-3"	—
v14	48	#14	52'-3"	—
v15(E)	71	#5	13'-11"	—
Cofferdam Excavation	Cu. Yd.	104.3		
Cofferdam (Type 2) (Location 2)	Each	1		
Concrete Structures	Cu. Yd.	118.0		
Seal Coat Concrete	Cu. Yd.	76.0		
Reinforcement Bars	Pound	42,970		
Reinforcement Bars, Epoxy Coated	Pound	21,650		
Permanent Casing	Foot	94.4		
Drilled Shaft in Soil	Cu. Yd.	108.8		
Drilled Shaft in Rock	Cu. Yd.	23.6		

Minimum lap for spirals = 1 1/2 turns
*** Length is height of spiral.