

EXISTING ROADWAY TYPICAL SECTION

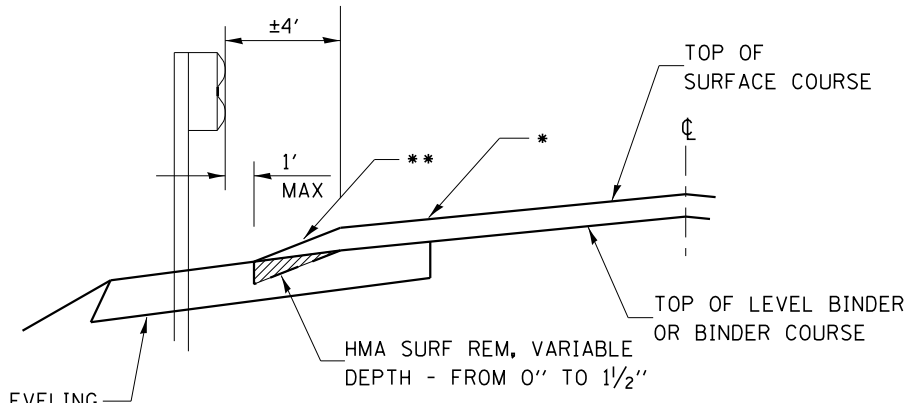

HMA SHOULDER 9" W/LEVELING BINDER-PLACE LEVELING BINDER PRIOR TO GUARDRAIL INSTALLATION

- * PROPOSED MAINLINE CROSS SLOPE, INCHES/FEET
- ** PROPOSED SHOULDER CROSS SLOPE, INCHES/FEET

SHOULDER DETAIL

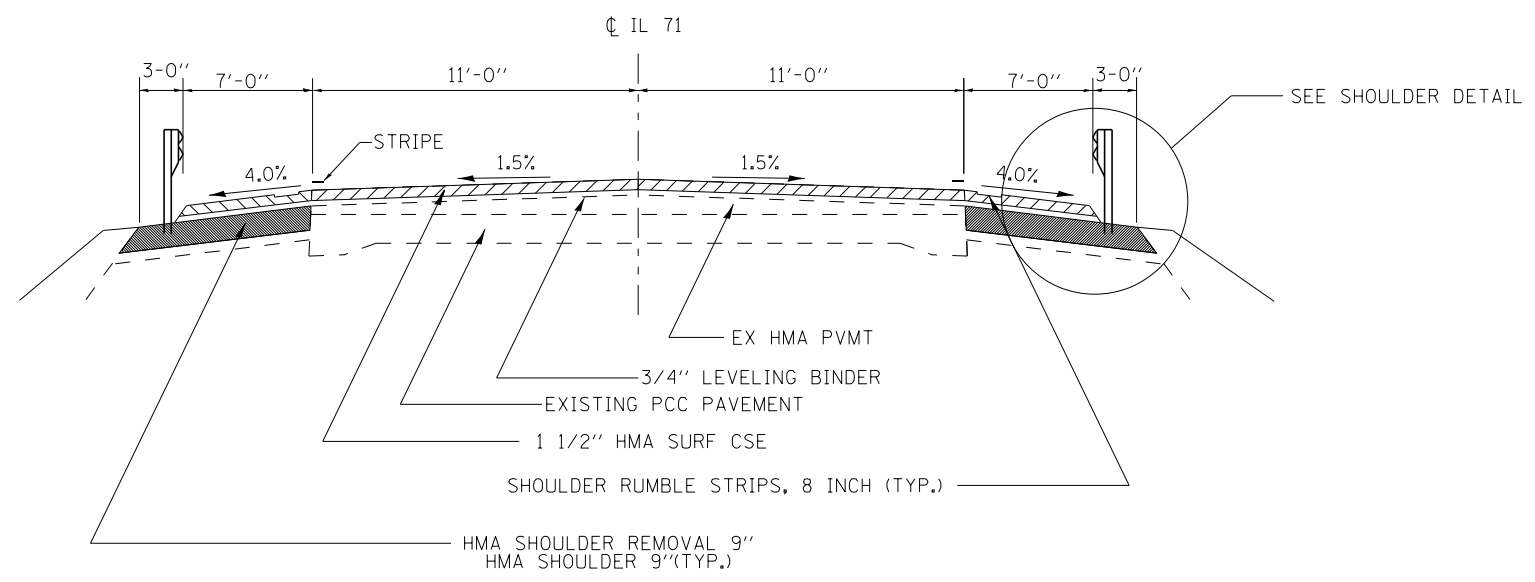

PROPOSED ROADWAY TYPICAL SECTION

	HMA Base Course, 15"	Level Binder	Surface	HMA Shoulder 9"
PG Grade	PG64-22	PG64-22	PG64-22	PG64-22
Design Air Voids	4.0% @ N50	4.0% @ N50	4.0% @ N50	2.0% @ N30
Mixture Composition	IL 19.0	IL 9.5	IL 9.5	IL 19.0L
Friction Aggregate			Mixture C	
Density Control	Cores	Satisfaction of Engineer	Cores	Cores