

ELEVATION AT ABUTMENT

TYPE I ELASTOMERIC EXP. BRG.

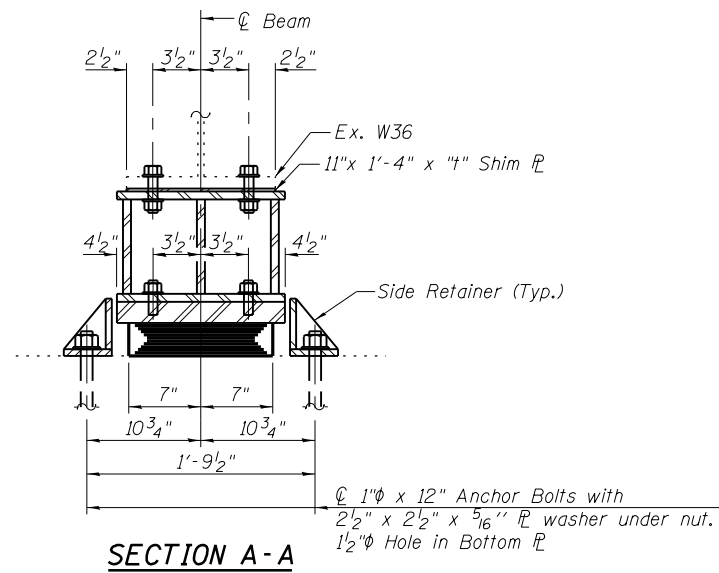

SECTION A-A

BEAM REACTIONS

R _D	(K)	36
R _L	(K)	43
Imp.	(K)	11
R (Total)	(K)	90

Notes:
 Diaphragm removal and reinstallation may be required to facilitate drilling holes. Cost included with Furnishing and Erecting Structural Steel.
 New steel extensions, shim plates and connection bolts are included with Furnishing and Erecting Structural Steel.
 Prior to ordering any material, the Contractor shall verify in the field all bearing height and shim thickness dimensions. Min. jack capacity = 27 Tons.
 Anchor bolts shall be ASTM F1554 all-thread (or an Engineer-approved alternate material) of the grade(s) and diameter(s) specified. ASTM A307 Grade C anchor bolts may be used in lieu of ASTM F1554 Grade 36 (Fy=36ksi). The corresponding specified grade of AASHTO M314 anchor bolts may be used in lieu of ASTM F1554.
 Anchor bolts at fixed bearings may be either cast in place or installed in holes drilled after the supported member is in place.
 Drilled and set anchor bolts shall be installed according to Article 521.06 of the Standard Specifications.
 Side retainers shall be included in the cost of Elastomeric Bearing Assembly, Type I.

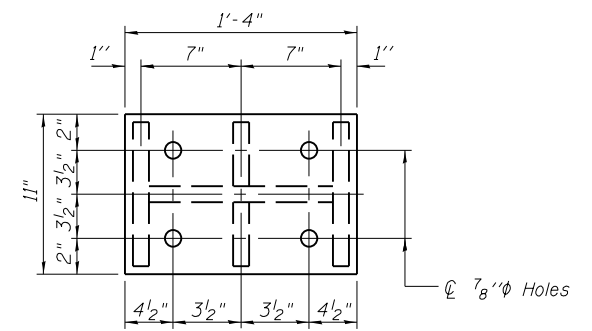

PLAN TOP AND BOTTOM PLATE

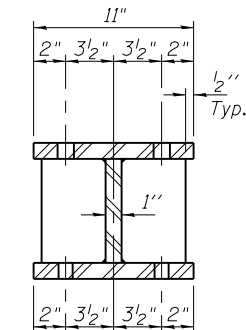

SECTION B-B

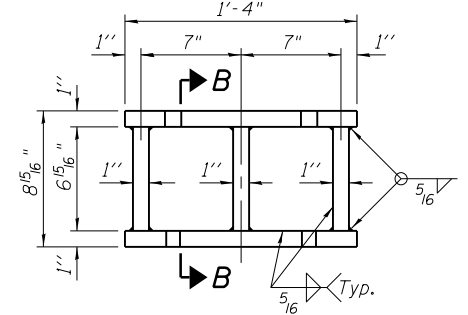

STEEL EXTENSION DETAIL

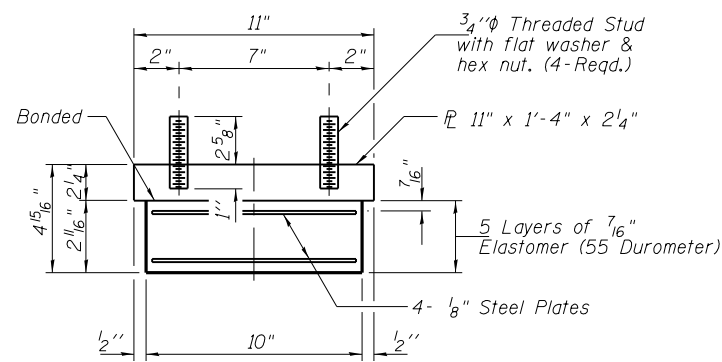

BEARING ASSEMBLY

Note:
 Shim plates shall not be placed under Bearing Assembly.

Bearing Shim Thickness - t (inches)									
Beams	1	2	3	4	5	6	7	8	9
So. Brg. Pier 2	5/8"	3/8"	--	1/2"	--	--	--	--	--

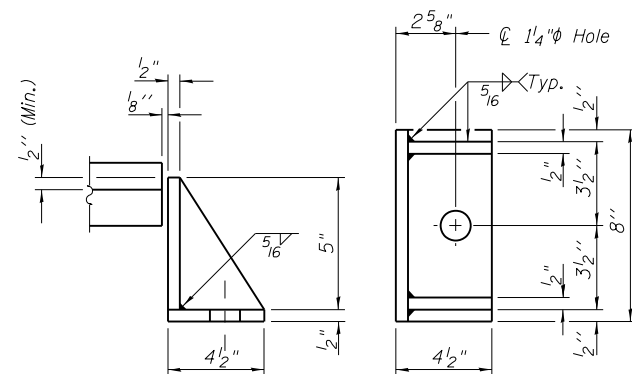

SIDE RETAINER

Equivalent rolled angle with stiffeners will be allowed in lieu of welded plates.

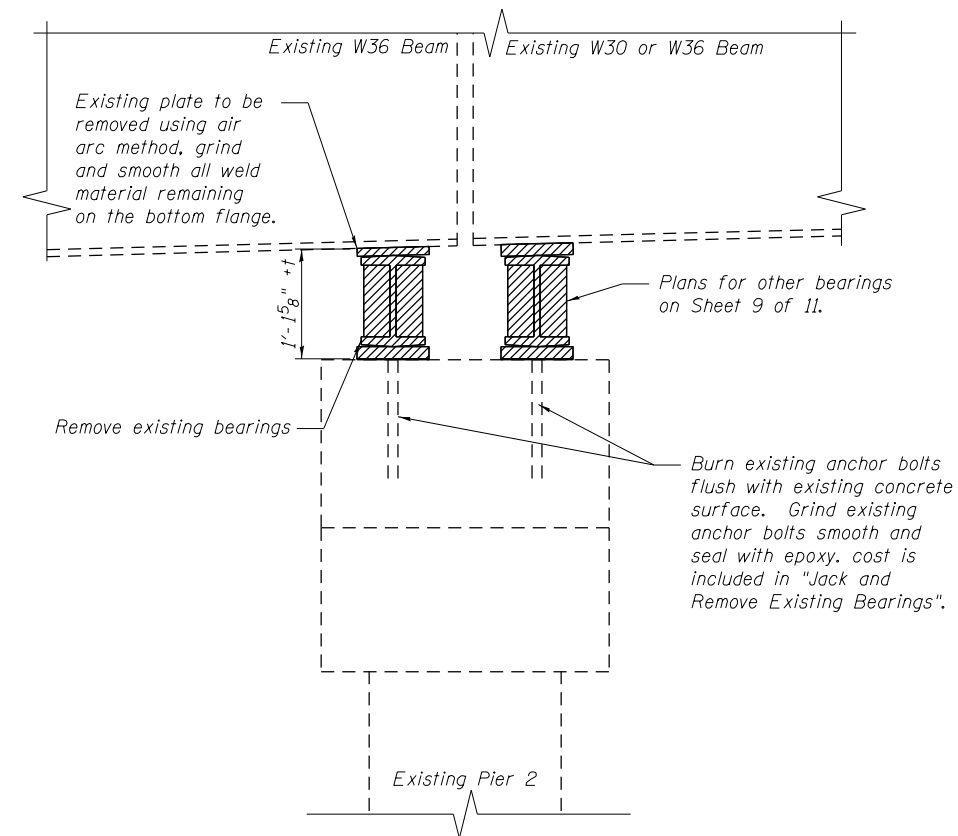

BILL OF MATERIAL

Item	Unit	Total
Elastomeric Bearing Assembly, Type I	Each	9
Jack and Remove Existing Bearings	Each	9
Furnishing and Erecting Structural Steel	Pound	1720
Anchor Bolts 1"φ	Each	18

TYI/REPS 12-03-2008
 BENTON & ASSOCIATES, INC.

FILE NAME = P:\10e2166-5\ Design\ Plans\ 0820166-76022-007-Bearings.dgn	USER NAME =	DESIGNED - MBH	REVISED - 10/3/13
		CHECKED - SJH	REVISED -
	PLOT SCALE =	DRAWN - MBH	REVISED -
	PLOT DATE =	CHECKED - SJH	REVISED -

STATE OF ILLINOIS
 DEPARTMENT OF TRANSPORTATION

PIER NO. 2 SOUTH BEARING DETAILS
 STRUCTURE NO. 082-0196

SHEET NO. 7 OF 11 SHEETS

F.A.I. RTE.	SECTION	COUNTY	TOTAL SHEETS	SHEET NO.
64	82-2HB-1	ST. CLAIR	208	204
CONTRACT NO. 76022				
FED. ROAD DIST. NO. 8 ILLINOIS FED. AID PROJECT				