

LEGEND

- WORK ZONE
- TRAFFIC FLOW ARROW
- TEMPORARY CONCRETE BARRIER
- TYPE II BARRICADES

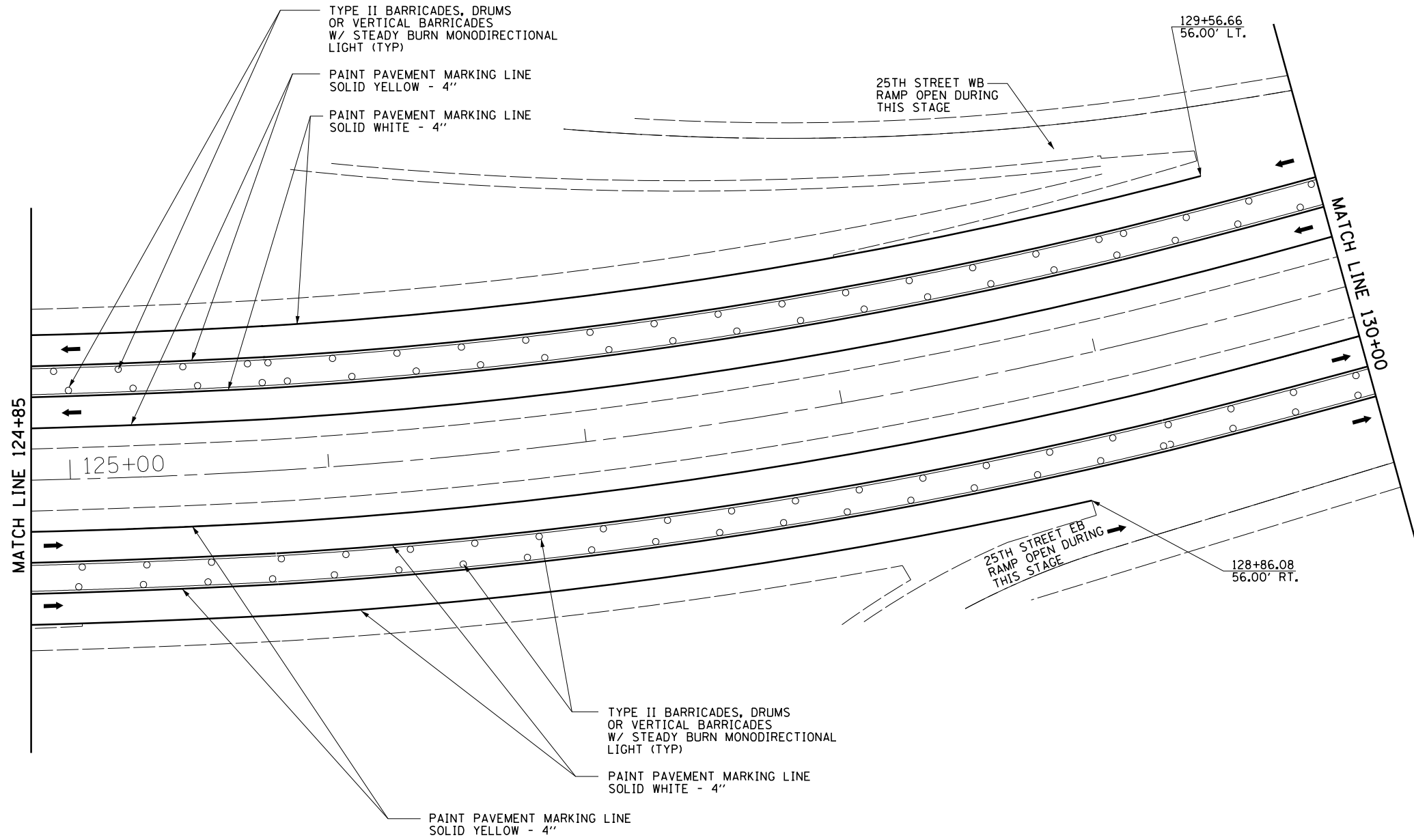

FILE NAME =	USER NAME = \$USER\$	DESIGNED - MBH	REVISED -
P:\10E2166-2\Design\Plans\0876022-sh-t-trafficcontrol-E.dgn		CHECKED - SJH	REVISED -
	PLOT SCALE = 50.0000' / in.	DRAWN - MBH	REVISED -
	PLOT DATE = 8/14/2013	CHECKED - SJH	REVISED -

**STATE OF ILLINOIS
DEPARTMENT OF TRANSPORTATION**

**TRAFFIC CONTROL PLAN - STAGE II
STA 124+85 TO 130+00**

SCALE: SHEET NO. 10 OF 15 SHEETS STA. TO STA.

F.A.I. RTE.	SECTION	COUNTY	TOTAL SHEETS	SHEET NO.
64	82-3HB-1	ST. CLAIR	208	101
CONTRACT NO. 76022				
<small>FED. ROAD DIST. NO. 8 ILLINOIS FED. AID PROJECT</small>				

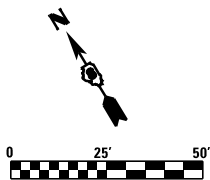

LEGEND

- WORK ZONE
- TRAFFIC FLOW ARROW
- TEMPORARY CONCRETE BARRIER
- TYPE II BARRICADES

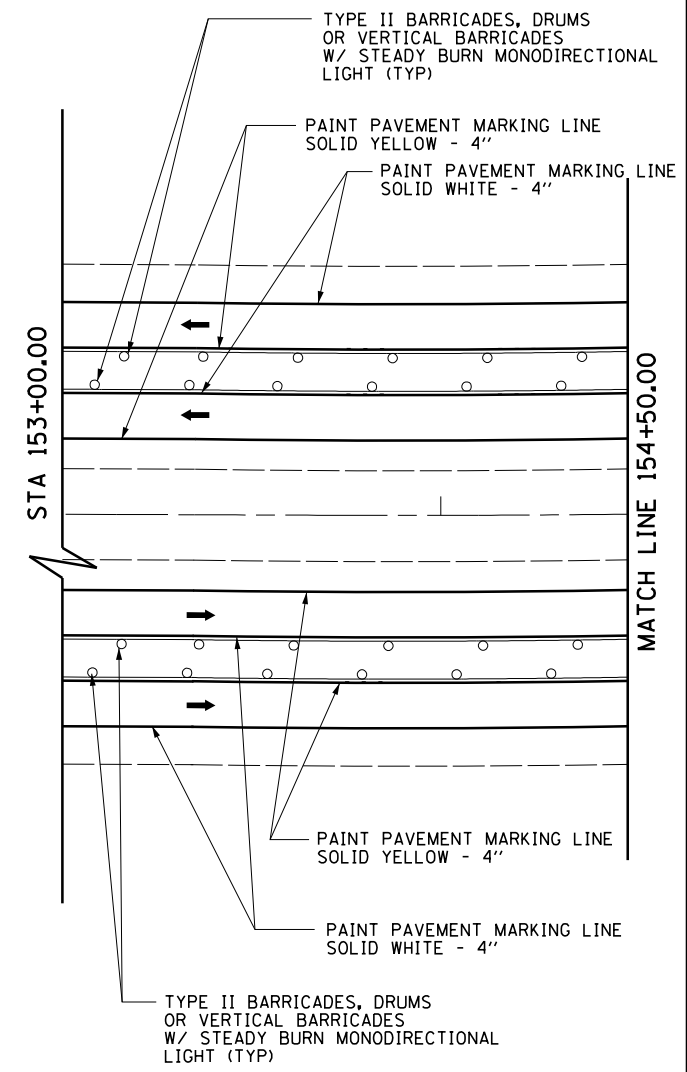
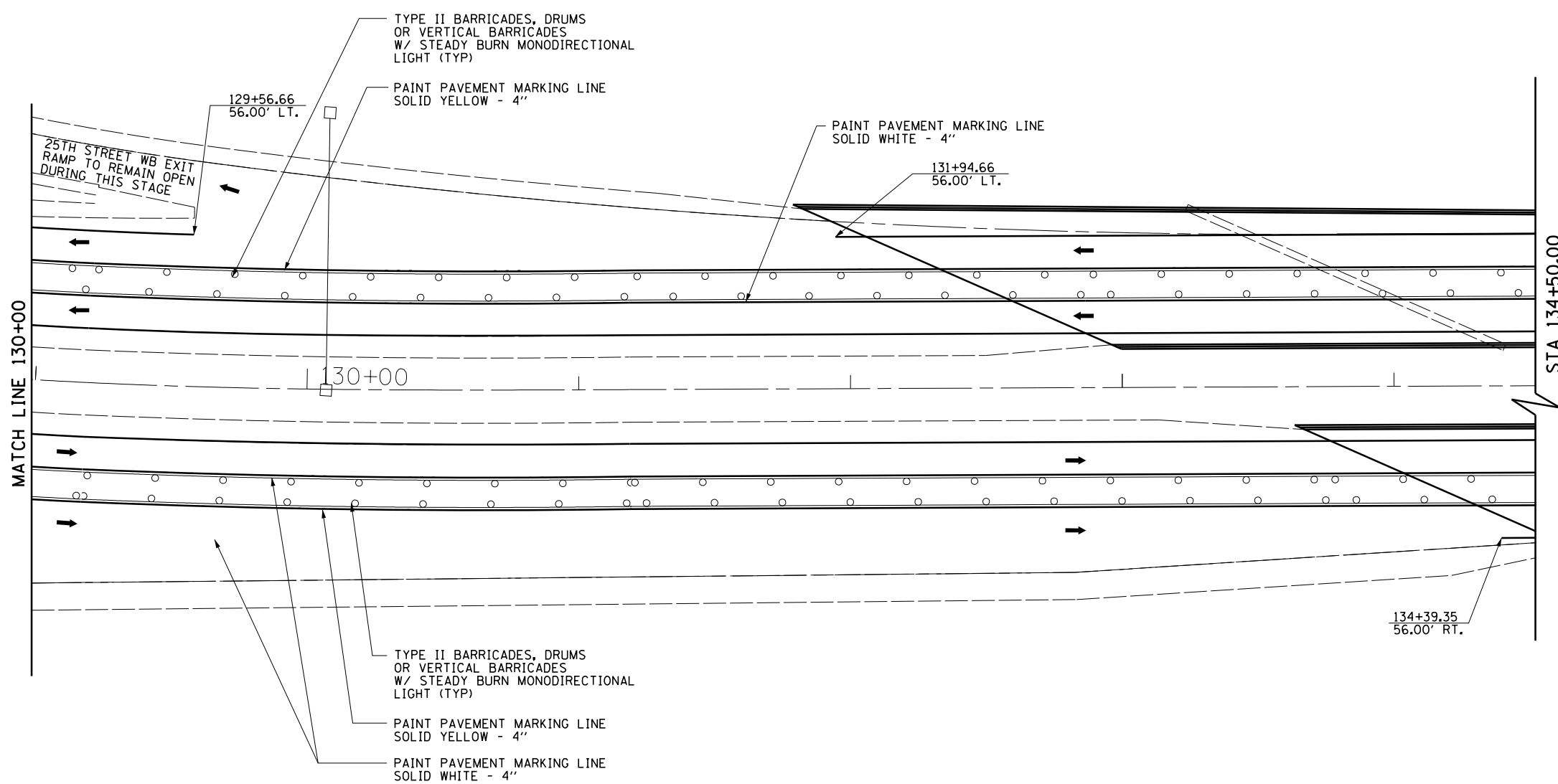

FILE NAME =	USER NAME = \$USER\$	DESIGNED - MBH	REVISED -
P:\10E2166-2\Design\Plans\0876022-sh-t-trafficcontrol-F.dgn		CHECKED - SJH	REVISED -
	PLOT SCALE = 50.0000' / in.	DRAWN - MBH	REVISED -
	PLOT DATE = 8/14/2013	CHECKED - SJH	REVISED -

STATE OF ILLINOIS
DEPARTMENT OF TRANSPORTATION

TRAFFIC CONTROL PLAN - STAGE II
STA 130+00 TO 154+50

SCALE: SHEET NO. 11 OF 15 SHEETS STA. TO STA.

F.A.I. RTE.	SECTION	COUNTY	TOTAL SHEETS	SHEET NO.
64	82-3HB-1	ST. CLAIR	208	102
CONTRACT NO. 76022				
FED. ROAD DIST. NO. 8 ILLINOIS FED. AID PROJECT				

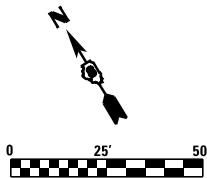

LEGEND

- WORK ZONE
- TRAFFIC FLOW ARROW
- TEMPORARY CONCRETE BARRIER
- TYPE II BARRICADES

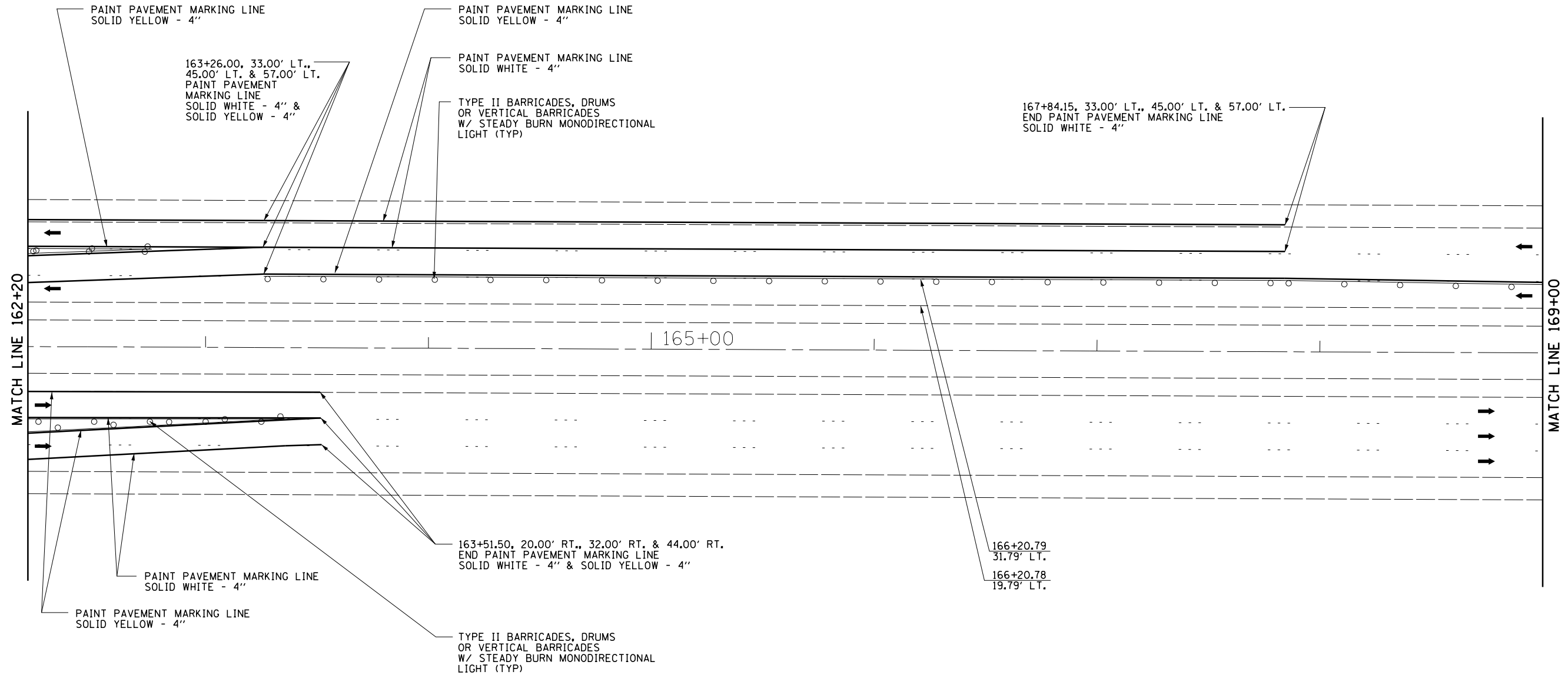

FILE NAME =	USER NAME = \$USER\$	DESIGNED - MBH	REVISED -
P:\10E2166-2\Design\Plans\0876022-sh-t-trafficcontrol-G.dgn		CHECKED - SJH	REVISED -
	PLOT SCALE = 50.0000' / in.	DRAWN - MBH	REVISED -
	PLOT DATE = 8/14/2013	CHECKED - SJH	REVISED -

**STATE OF ILLINOIS
DEPARTMENT OF TRANSPORTATION**

**TRAFFIC CONTROL PLAN - STAGE II
STA 162+20 TO 169+00**

SCALE: SHEET NO. 13 OF 15 SHEETS STA. TO STA.

F.A.I. RTE.	SECTION	COUNTY	TOTAL SHEETS	SHEET NO.
64	82-3HB-1	ST. CLAIR	208	104
CONTRACT NO. 76022				
FED. ROAD DIST. NO. 8 ILLINOIS FED. AID PROJECT				

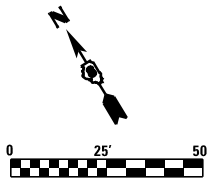

LEGEND

- WORK ZONE
- TRAFFIC FLOW ARROW
- TEMPORARY CONCRETE BARRIER
- TYPE II BARRICADES

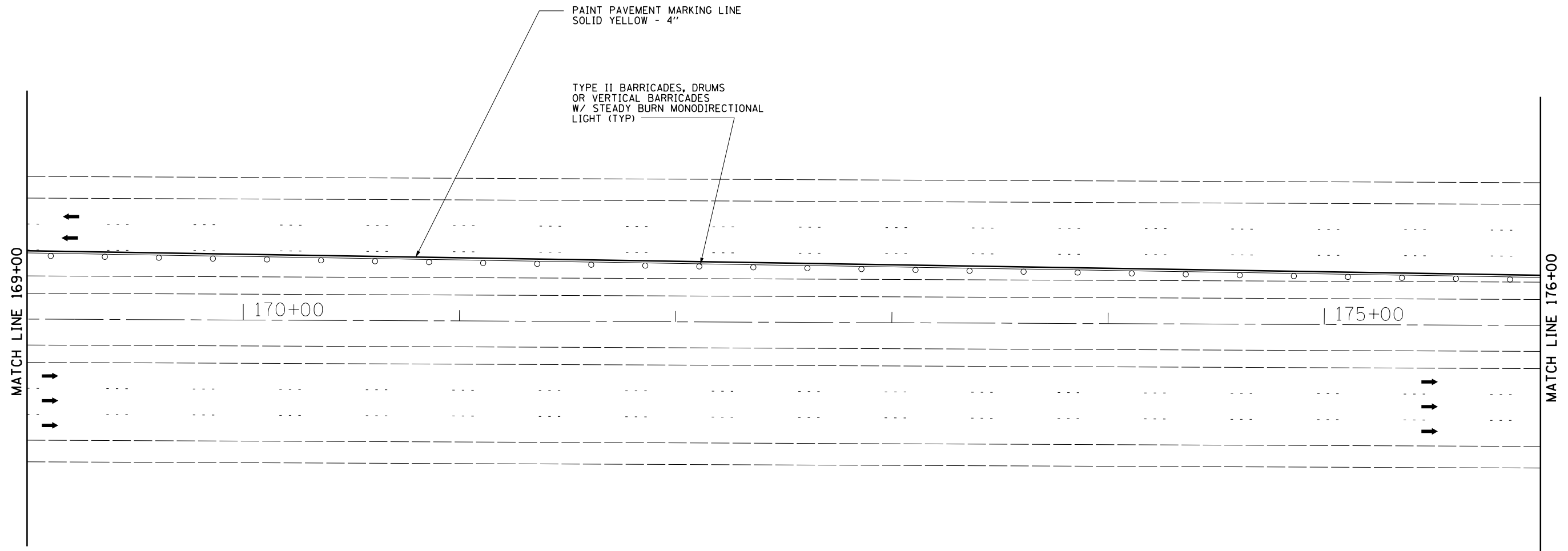

FILE NAME =	USER NAME = \$USER\$	DESIGNED - MBH	REVISED -
P:\10E2166-2\Design\Plans\0876022-sh-t-trafficcontrol-H.dgn		CHECKED - SJH	REVISED -
	PLOT SCALE = 50.0000' / in.	DRAWN - MBH	REVISED -
	PLOT DATE = 8/14/2013	CHECKED - SJH	REVISED -

**STATE OF ILLINOIS
DEPARTMENT OF TRANSPORTATION**

**TRAFFIC CONTROL PLAN - STAGE II
STA 169+00 TO 176+00**

SCALE: SHEET NO. 14 OF 15 SHEETS STA. TO STA.

F.A.I. RTE.	SECTION	COUNTY	TOTAL SHEETS	SHEET NO.
64	82-3HB-1	ST. CLAIR	208	105
CONTRACT NO. 76D22				
FED. ROAD DIST. NO. 8 ILLINOIS FED. AID PROJECT				

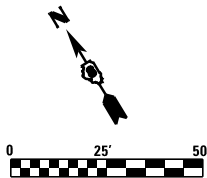

LEGEND

- WORK ZONE
- TRAFFIC FLOW ARROW
- TEMPORARY CONCRETE BARRIER
- TYPE II BARRICADES

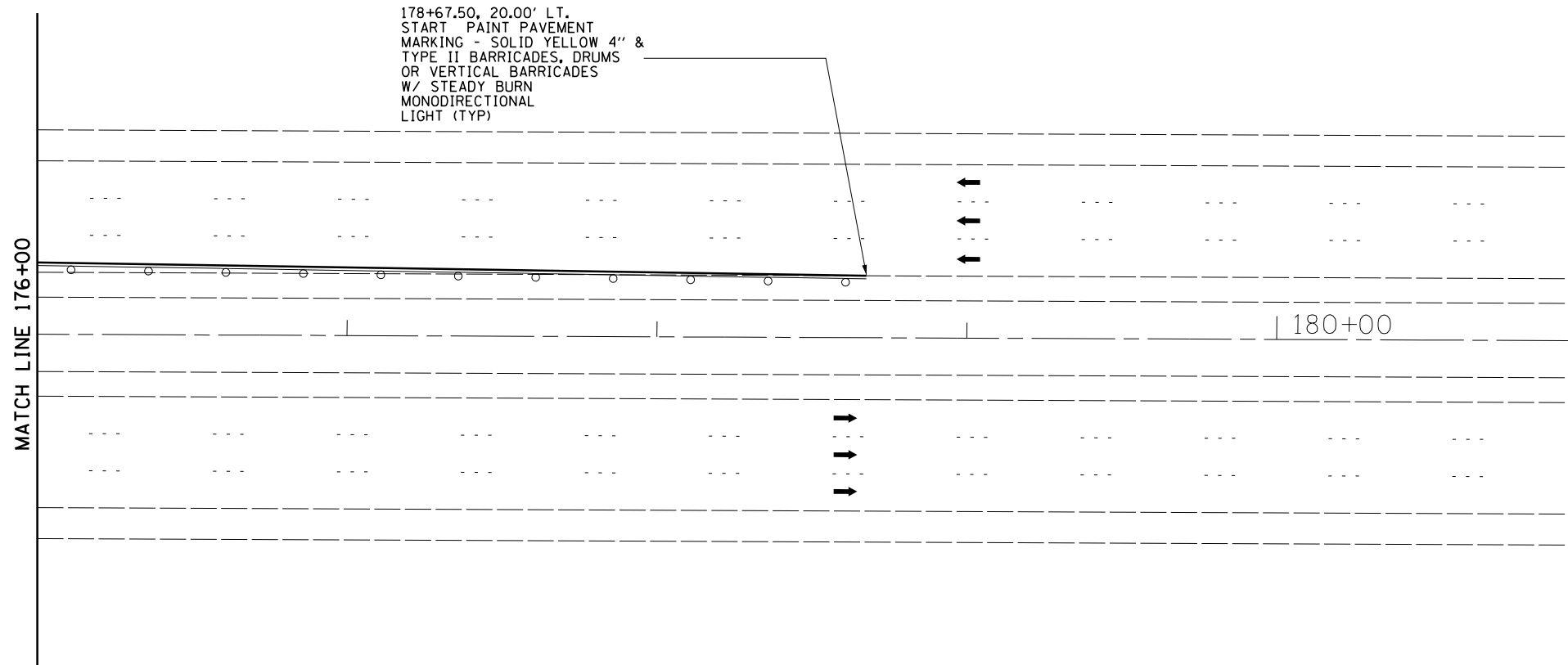

FILE NAME =	USER NAME = \$USER\$	DESIGNED - MBH	REVISED -
P:\10E2166-2\Design\Plans\0876022-sh-t-trafficcontrol-1.dgn		CHECKED - SJH	REVISED -
	PLOT SCALE = 50.0000' / in.	DRAWN - MBH	REVISED -
	PLOT DATE = 8/14/2013	CHECKED - SJH	REVISED -

**STATE OF ILLINOIS
DEPARTMENT OF TRANSPORTATION**

**TRAFFIC CONTROL PLAN - STAGE II
STA 176+00 TO 181+00**

SCALE: SHEET NO. 15 OF 15 SHEETS STA. TO STA.

F.A.I. RTE.	SECTION	COUNTY	TOTAL SHEETS	SHEET NO.
64	82-3HB-1	ST. CLAIR	208	106
CONTRACT NO. 76D22				
FED. ROAD DIST. NO. 8 ILLINOIS FED. AID PROJECT				

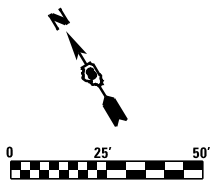

LEGEND

- WORK ZONE
- TRAFFIC FLOW ARROW
- TEMPORARY CONCRETE BARRIER
- TYPE II BARRICADES

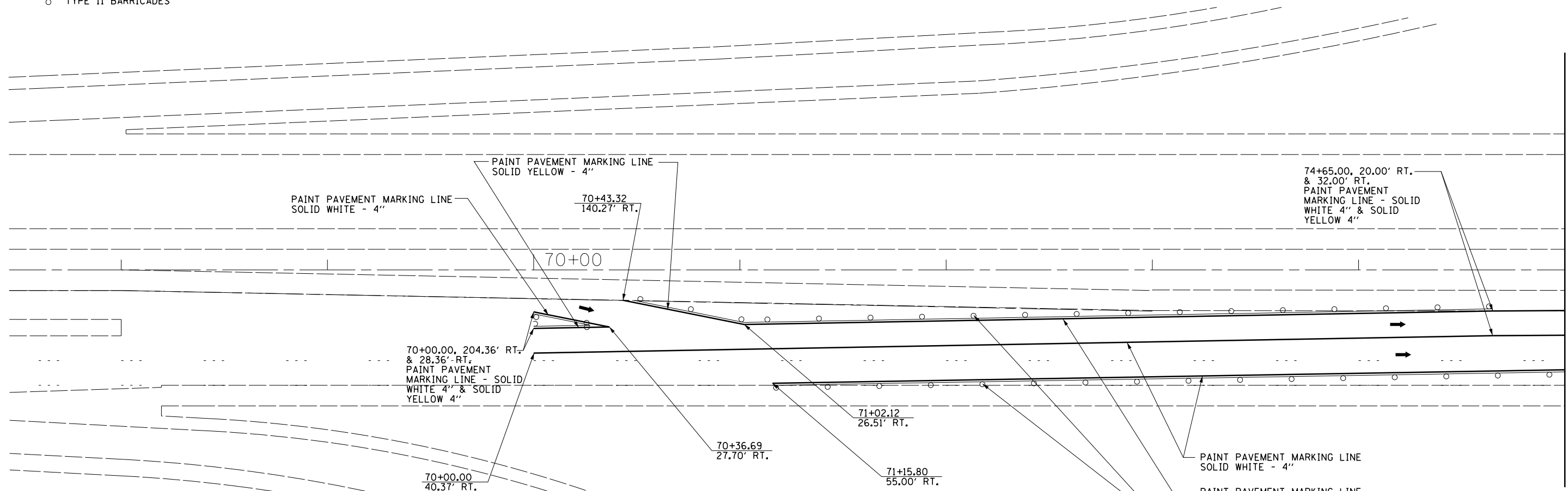

NOTES

1. STANDARD 701411-08 SHALL BE USED FOR TRAFFIC CONTROL ON F.A.I. 64 EASTBOUND F.A.I. 55 ENTRANCE RAMP, 16TH STREET ENTRANCE RAMP ALONG WITH F.A.I. 64 WESTBOUND 25TH STREET ENTRANCE & EXIT RAMP.
2. TRAFFIC CONTROL SIGNS SHALL BE PLACED ON BOTH THE LEFT AND RIGHT SIDE OF THE PAVEMENT.
3. TEMPORARY CONCRETE BARRIER SHALL HAVE TWO (2) BARRIER WALL MARKERS PLACED ON TOP OF EACH OTHER, SEE DETAIL A. IN LOCATIONS WHERE THE GLARE SCREEN IS NOT PRESENT A BARRIER WALL MARKER SHALL BE USED ON THE TOP OF EACH TEMPORARY CONCRETE BARRIER. ALL BARRIER WALL MARKERS SHALL BE PLACED AT 25' CENTERS UNLESS OTHERWISE SPECIFIED BY THE ENGINEER. SEE STANDARD 704001-07. THESE ADDITIONAL BARRIER WALL MARKERS SHALL BE INCLUDED IN THE COST OF TEMPORARY CONCRETE BARRIER.
4. ALL TRAFFIC CONTROL DEVICES SHALL BE IN ACCORDANCE WITH STANDARD 701901-02.
5. CONTRACTOR TO PROVIDE "SPEED INDICATOR SIGN" FOR PLACEMENT IN WORK ZONE AS DIRECTED BY THE ENGINEER.
6. THE EASTBOUND 25TH STREET EXIT & ENTRANCE RAMP ALONG WITH THE WESTBOUND BAUGH AVENUE EXIT RAMP CLOSURES SHALL BE COORDINATED WITH IDOT. THE CONTRACTOR SHALL BE RESPONSIBLE FOR ALL MATERIALS AND LABOR REQUIRED TO CLOSE RAMP. SEE TRAFFIC DETOUR PLANS FOR DETOUR SIGNING REQUIREMENTS.

STAGE III TRAFFIC CONTROL STANDARDS
 701400-05 - USE FOR APPROACH TO LANE CLOSURE
 701401-06 - USE FOR SHOULDER WORK
 701402-09 - USE FOR LANE CLOSURE WITH BARRIER
 701411-08 - USE FOR SHOULDER AND LANE CLOSURE NEAR ENTRANCE/EXIT RAMP
 701451-01 - USE FOR RAMP CLOSURE
 701901-02 - USE FOR TRAFFIC CONTROL DEVICES
 704001-07 - USE FOR TEMPORARY CONCRETE BARRIER
 720001-01 & 720006-03 - USE FOR PROPOSED CONSTRUCTION SIGNS
 780001-03 - USE FOR STAGING PAVEMENT MARKINGS

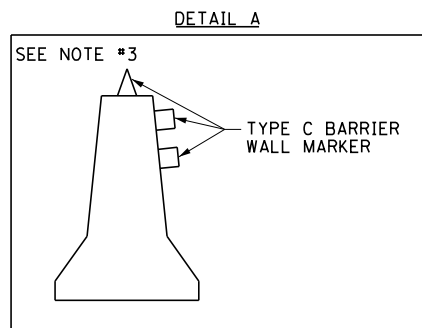

SUGGESTED PRE-STAGE III PROCEDURES

1. REMOVE EXISTING PAVEMENT MARKINGS USED FOR STAGE II TRAFFIC CONTROL.
2. PLACE TRAFFIC CONTROL MARKINGS AS SHOWN ON THE PLANS FOR STAGE III WORK.
3. INSTALL SIGNAGE AND TRAFFIC CONTROL DEVICES FOR STAGE III DETOURS FOR THE 25th STREET EXIT/ENTRANCE RAMP AND THE BAUGH AVENUE EXIT RAMP.
4. MOVE ALL TRAFFIC TO STAGE III TRAFFIC LANES.
5. RELOCATE TEMPORARY CONCRETE BARRIERS, TEMPORARY IMPACT ATTENUATORS AND TRAFFIC CONTROL DEVICES.
6. COMPLETE IMPROVEMENTS IN STAGE II WORK ZONE ON ALL STRUCTURES INCLUDING STRUCTURE 082-0196.

SUGGESTED POST-STAGE PROCEDURES

1. REMOVE ALL TEMPORARY CONCRETE BARRIERS, TEMPORARY IMPACT ATTENUATORS AND TRAFFIC CONTROL DEVICES.
2. REMOVE SIGNAGE AND TRAFFIC CONTROL DEVICES USED FOR RAMP DETOURS.
3. REMOVE ALL EXISTING PAVEMENT MARKINGS USED FOR STAGE III TRAFFIC CONTROL.
4. PLACE TEMPORARY PAVEMENT MARKINGS FOR FULL FREEWAY USE.

FILE NAME =	USER NAME = \$USER\$	DESIGNED - MBH	REVISED -
P:\10E2166-2\Design\Plans\0876022-sh1-trafficcontrol-A.dgn		CHECKED - SJH	REVISED -
	PLOT SCALE = 50.0000' / in.	DRAWN - MBH	REVISED -
	PLOT DATE = 8/14/2013	CHECKED - SJH	REVISED -

**STATE OF ILLINOIS
DEPARTMENT OF TRANSPORTATION**

**TRAFFIC CONTROL PLAN - STAGE III
STA 67+50 TO 75+00**

SCALE: SHEET NO. 1 OF 14 SHEETS STA. TO STA.

F.A.I. RTE.	SECTION	COUNTY	TOTAL SHEETS	SHEET NO.
64	82-3HB-1	ST. CLAIR	208	107
CONTRACT NO. 76D22				
FED. ROAD DIST. NO. 8 ILLINOIS FED. AID PROJECT				

MATCH LINE 75+00

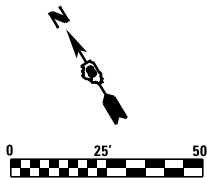

LEGEND

- WORK ZONE
- TRAFFIC FLOW ARROW
- TEMPORARY CONCRETE BARRIER
- TYPE II BARRICADES

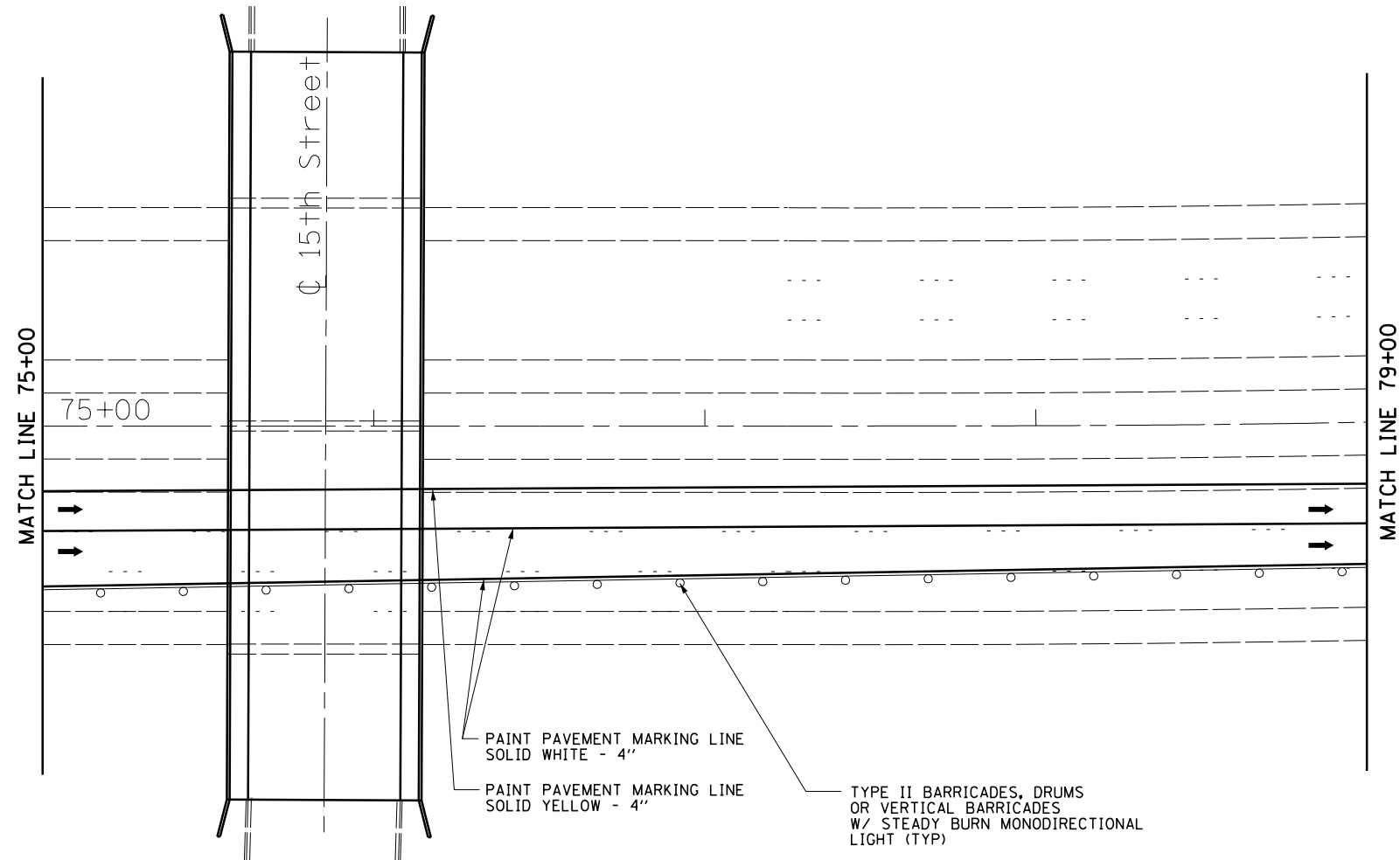

PAINT PAVEMENT MARKING LINE
SOLID WHITE - 4"

PAINT PAVEMENT MARKING LINE
SOLID YELLOW - 4"

TYPE II BARRICADES, DRUMS
OR VERTICAL BARRICADES
W/ STEADY BURN MONODIRECTIONAL
LIGHT (TYP)

FILE NAME =	USER NAME = \$USER\$	DESIGNED - MBH	REVISED -
P:\10E2166-2\Design\Plans\0876022-sh-t-trafficcontrol-B.dgn		CHECKED - SJH	REVISED -
	PLOT SCALE = 50.0000' / in.	DRAWN - MBH	REVISED -
	PLOT DATE = 8/14/2013	CHECKED - SJH	REVISED -

**STATE OF ILLINOIS
DEPARTMENT OF TRANSPORTATION**

**TRAFFIC CONTROL PLAN - STAGE III
STA 75+00 TO 79+00**

SCALE: SHEET NO. 2 OF 14 SHEETS STA. TO STA.

F.A.I. RTE.	SECTION	COUNTY	TOTAL SHEETS	SHEET NO.
64	82-3HB-1	ST. CLAIR	208	108
CONTRACT NO. 76022				
<small>FED. ROAD DIST. NO. 8 ILLINOIS FED. AID PROJECT</small>				

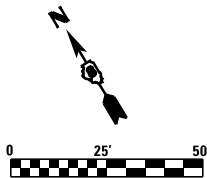

LEGEND

- WORK ZONE
- TRAFFIC FLOW ARROW
- TEMPORARY CONCRETE BARRIER
- TYPE II BARRICADES

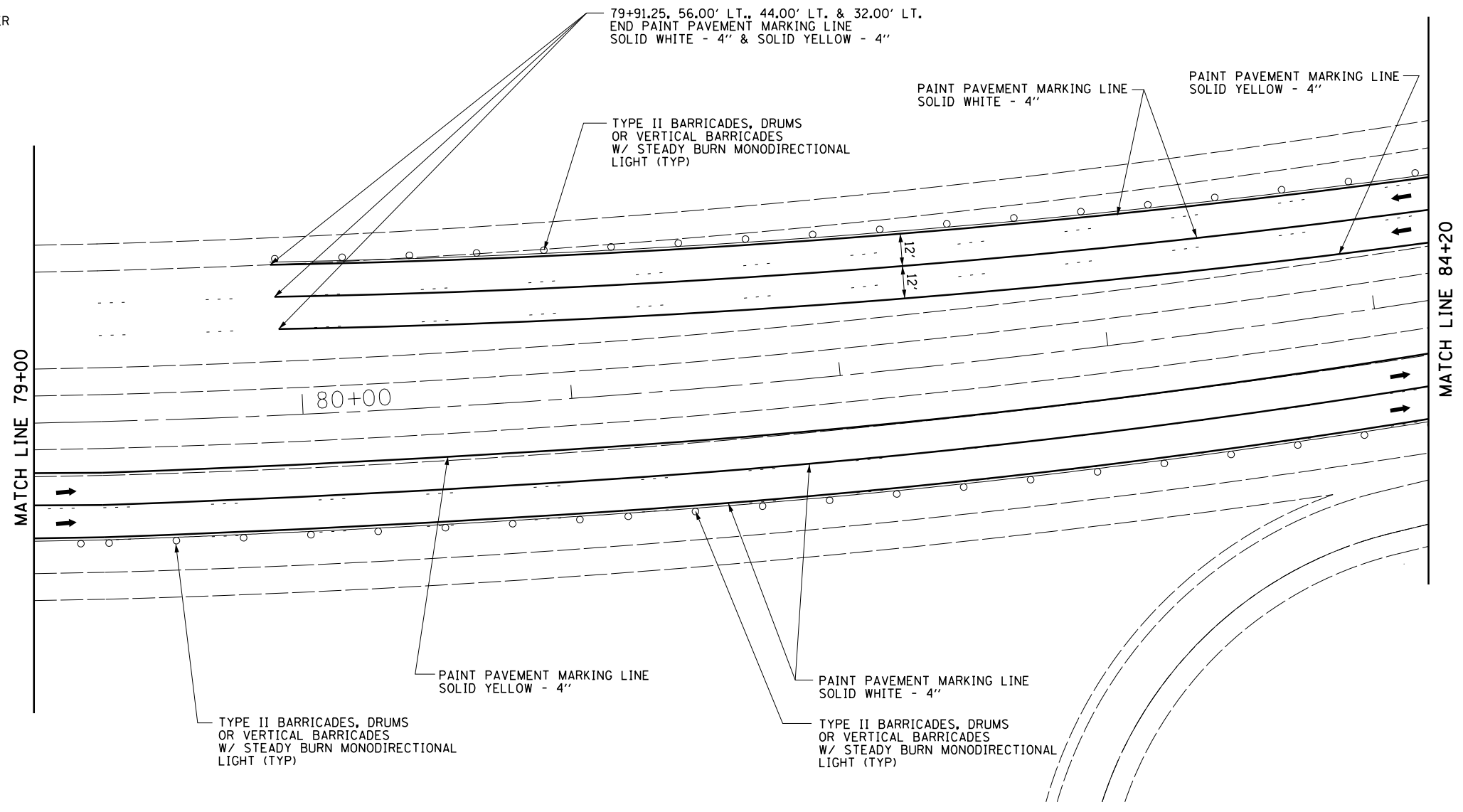

FILE NAME =	USER NAME = \$USER\$	DESIGNED - MBH	REVISED -
P:\10E2166-2\Design\Plans\0876022-sh-t-trafficcontrol-C.dgn		CHECKED - SJH	REVISED -
	PLOT SCALE = 50.0000' / in.	DRAWN - MBH	REVISED -
	PLOT DATE = 8/14/2013	CHECKED - SJH	REVISED -

**STATE OF ILLINOIS
DEPARTMENT OF TRANSPORTATION**

**TRAFFIC CONTROL PLAN - STAGE III
STA 79+00 TO 84+20**

SCALE: SHEET NO. 3 OF 14 SHEETS STA. TO STA.

F.A.I. RTE.	SECTION	COUNTY	TOTAL SHEETS	SHEET NO.
64	82-3HB-1	ST. CLAIR	208	109
CONTRACT NO. 76D22				
FED. ROAD DIST. NO. 8 ILLINOIS FED. AID PROJECT				

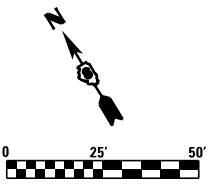

LEGEND

- WORK ZONE
- TRAFFIC FLOW ARROW
- TEMPORARY CONCRETE BARRIER
- TYPE II BARRICADES
- SHOULDER REPLACEMENT

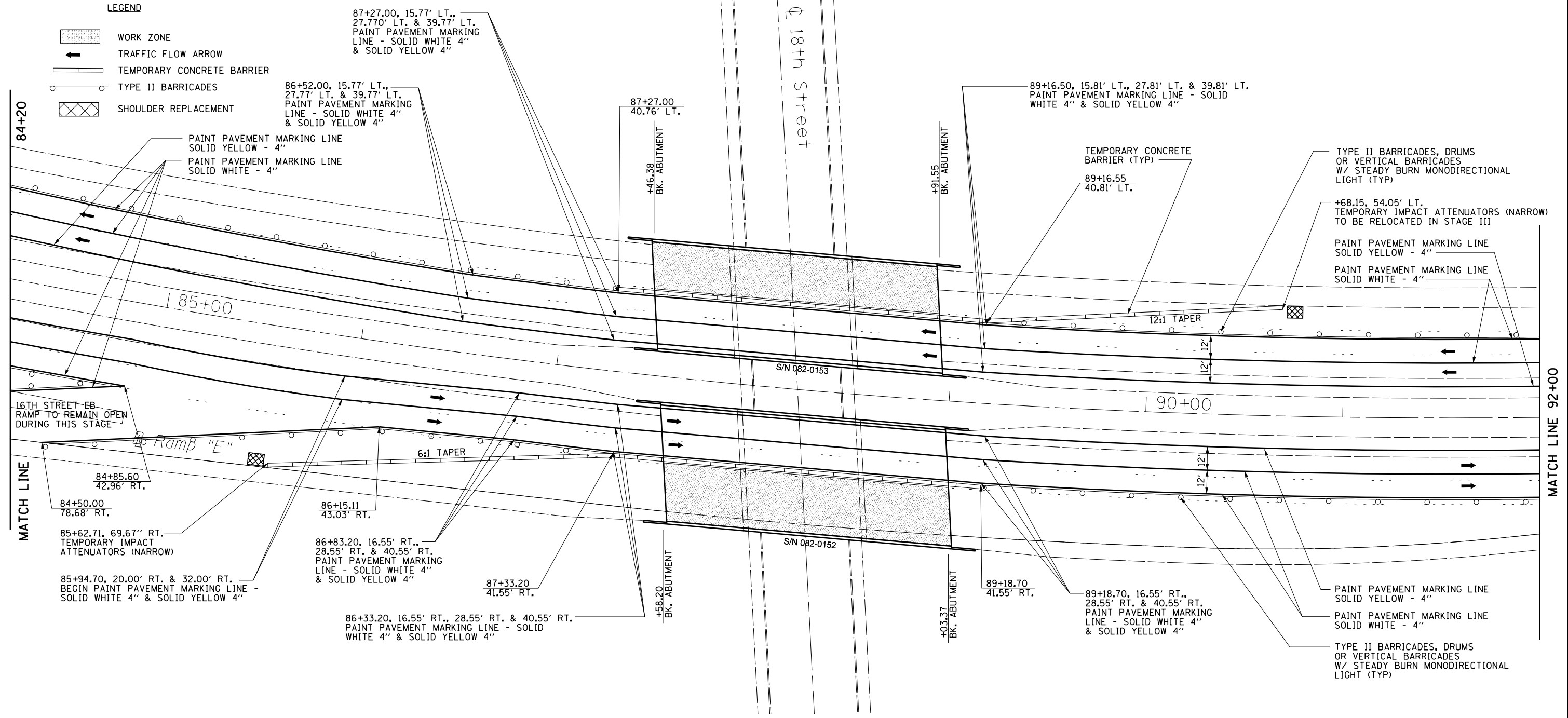

FILE NAME =	USER NAME = \$USER\$	DESIGNED - MBH	REVISED -
P:\10E2166-2\Design\Plans\0876022-sh-t-trafficcontrol-Cl.dgn		CHECKED - SJH	REVISED -
	PLOT SCALE = 50.0000' / in.	DRAWN - MBH	REVISED -
	PLOT DATE = 8/14/2013	CHECKED - SJH	REVISED -

**STATE OF ILLINOIS
DEPARTMENT OF TRANSPORTATION**

**TRAFFIC CONTROL PLAN - STAGE III
STA 84+20 TO 92+00**

SCALE: SHEET NO. 4 OF 14 SHEETS STA. TO STA.

F.A.I. RTE.	SECTION	COUNTY	TOTAL SHEETS	SHEET NO.
64	82-3HB-1	ST. CLAIR	208	110
CONTRACT NO. 76022				
FED. ROAD DIST. NO. 8 ILLINOIS FED. AID PROJECT				

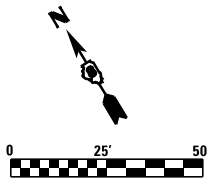

LEGEND

- WORK ZONE
- TRAFFIC FLOW ARROW
- TEMPORARY CONCRETE BARRIER
- TYPE II BARRICADES

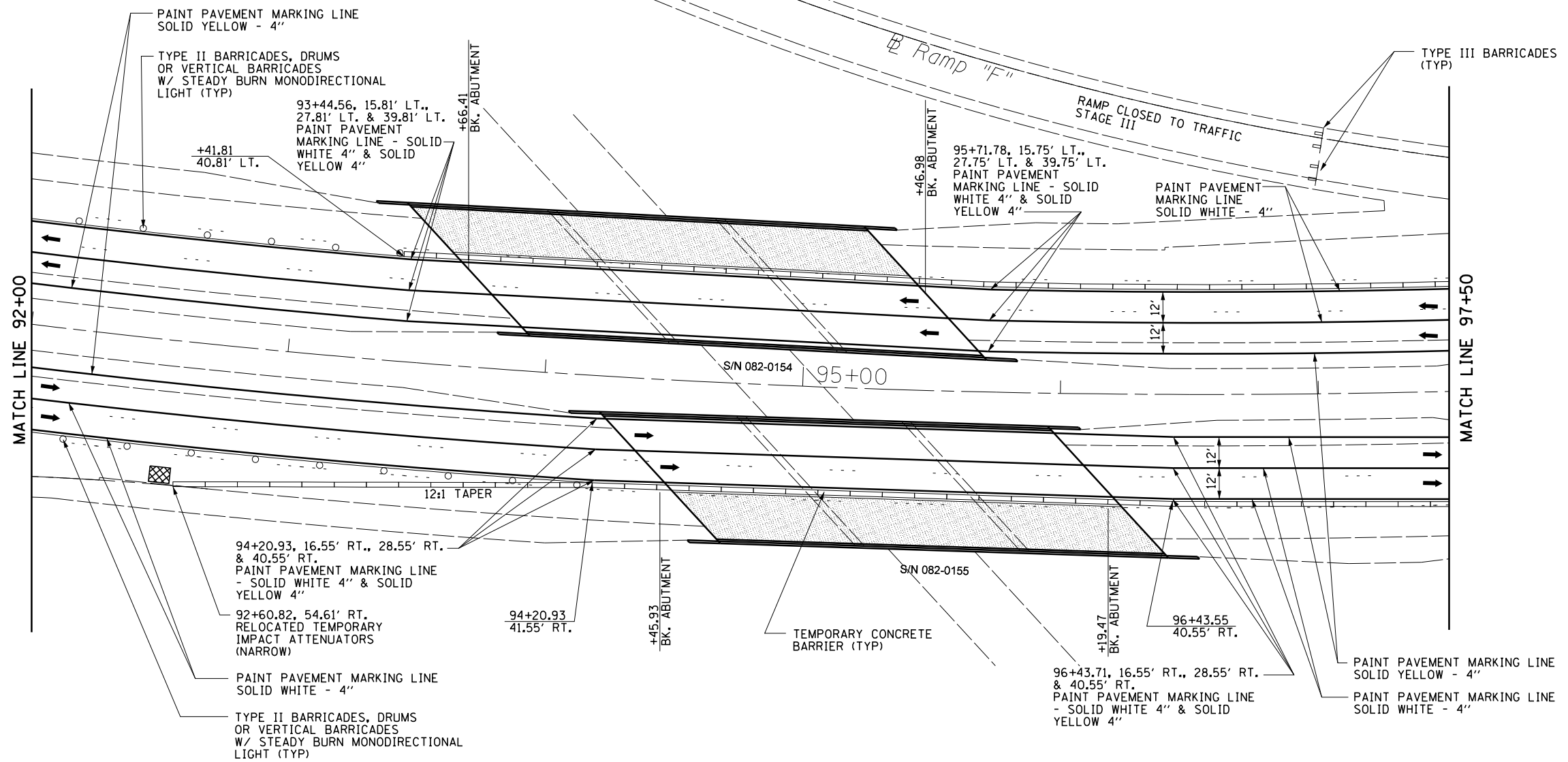

FILE NAME =	USER NAME = \$USER\$	DESIGNED - MBH	REVISED -
P:\10E2166-2\Design\Plans\0876022-sh-t-trafficcontrol-C2.dgn		CHECKED - SJH	REVISED -
	PLOT SCALE = 50.0000' / in.	DRAWN - MBH	REVISED -
	PLOT DATE = 8/14/2013	CHECKED - SJH	REVISED -

**STATE OF ILLINOIS
DEPARTMENT OF TRANSPORTATION**

**TRAFFIC CONTROL PLAN - STAGE III
STA 92+00 TO 97+50**

SCALE: SHEET NO. 5 OF 14 SHEETS STA. TO STA.

F.A.I. RTE.	SECTION	COUNTY	TOTAL SHEETS	SHEET NO.
64	82-3HB-1	ST. CLAIR	208	111
CONTRACT NO. 76022				
<small>FED. ROAD DIST. NO. 8 ILLINOIS FED. AID PROJECT</small>				



LEGEND

- WORK ZONE
- TRAFFIC FLOW ARROW
- TEMPORARY CONCRETE BARRIER
- TYPE II BARRICADES

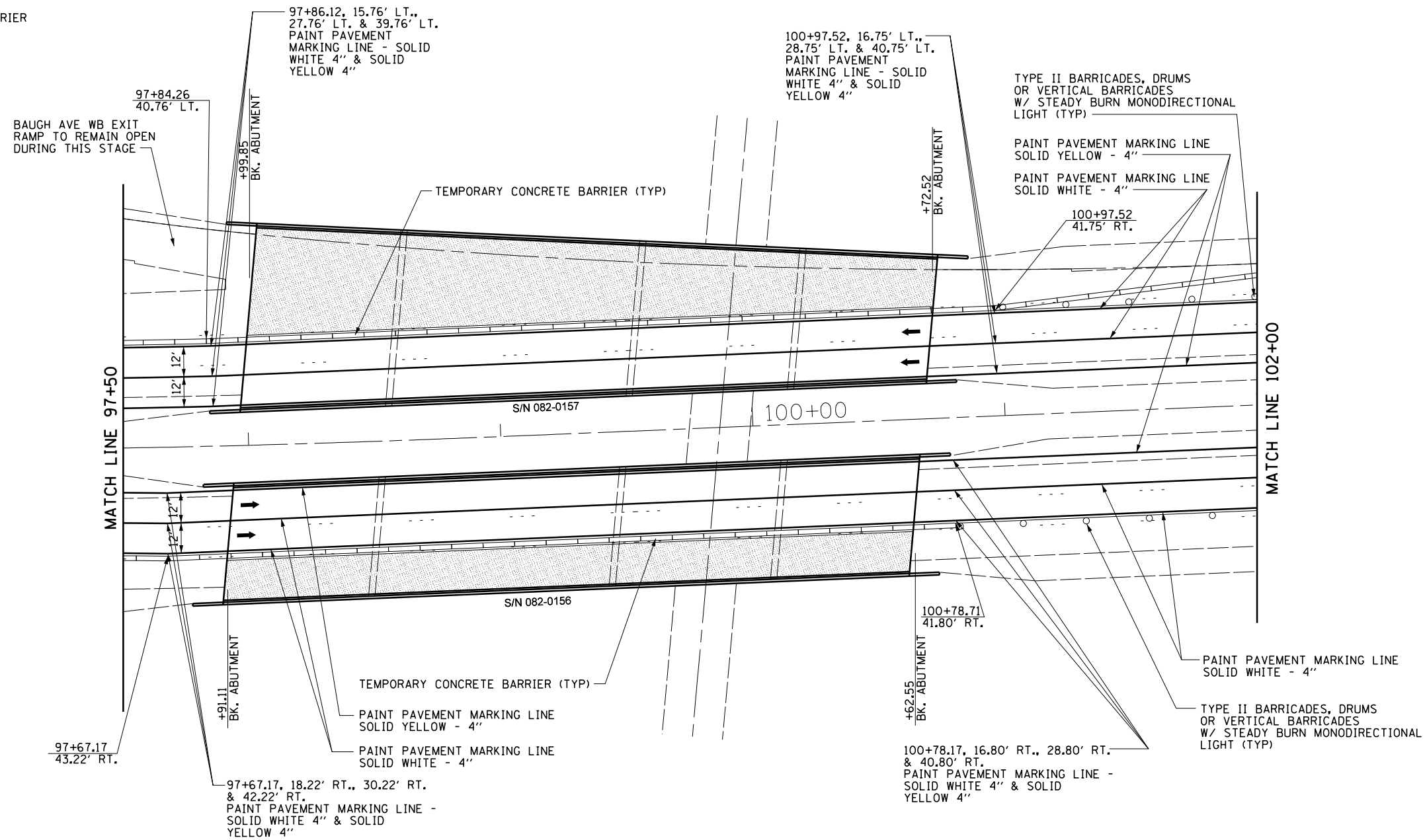

FILE NAME =	USER NAME = \$USER\$	DESIGNED - MBH	REVISED -
P:\10E2166-2\Design\Plans\0876022-sh-t-trafficcontrol-C3.dgn		CHECKED - SJH	REVISED -
	PLOT SCALE = 50.0000' / in.	DRAWN - MBH	REVISED -
	PLOT DATE = 8/14/2013	CHECKED - SJH	REVISED -

**STATE OF ILLINOIS
DEPARTMENT OF TRANSPORTATION**

**TRAFFIC CONTROL PLAN - STAGE III
STA 97+50 TO 102+00**

SCALE: SHEET NO. 6 OF 14 SHEETS STA. TO STA.

F.A.I. RTE.	SECTION	COUNTY	TOTAL SHEETS	SHEET NO.
64	82-3HB-1	ST. CLAIR	208	112
CONTRACT NO. 76022				
FED. ROAD DIST. NO. 8 ILLINOIS FED. AID PROJECT				

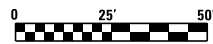

LEGEND

- WORK ZONE
- TRAFFIC FLOW ARROW
- TEMPORARY CONCRETE BARRIER
- TYPE II BARRICADES

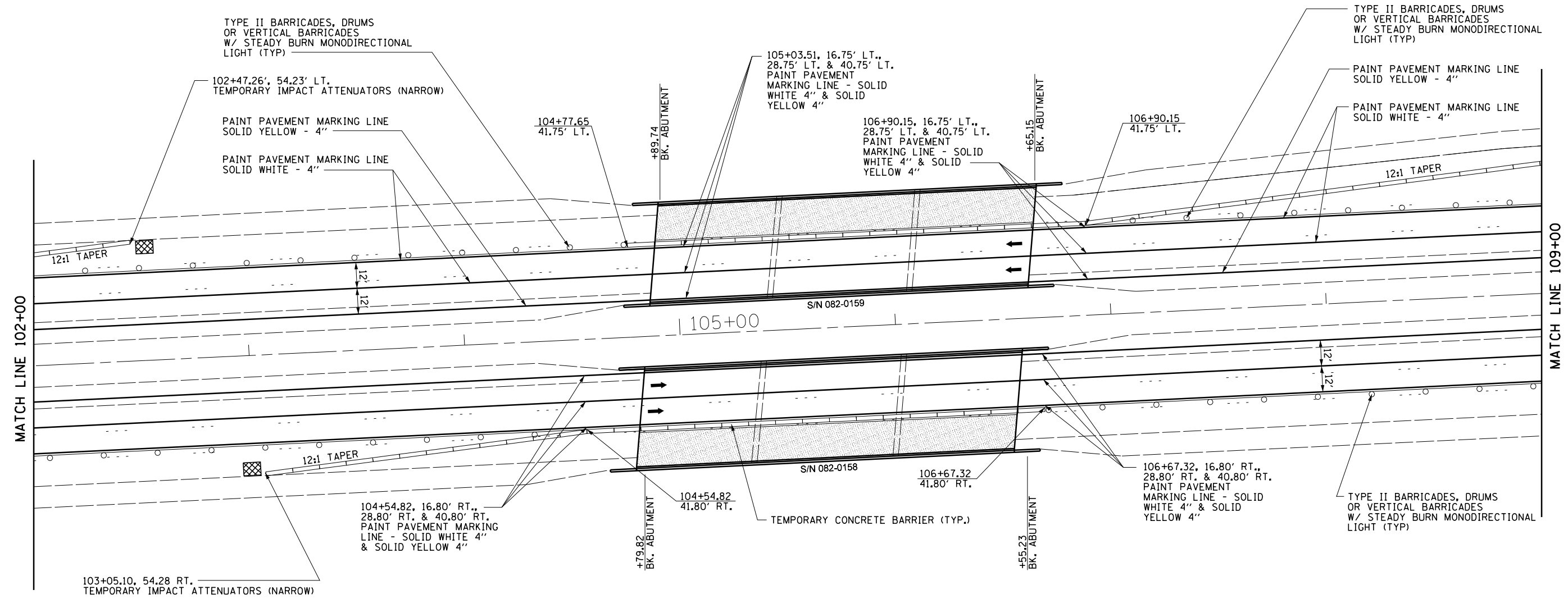

FILE NAME =	USER NAME = \$USER\$	DESIGNED - MBH	REVISED -
P:\10E2166-2\Design\Plans\0876022-sh-t-trafficcontrol-C4.dgn		CHECKED - SJH	REVISED -
	PLOT SCALE = 50.0000' / in.	DRAWN - MBH	REVISED -
	PLOT DATE = 8/14/2013	CHECKED - SJH	REVISED -

**STATE OF ILLINOIS
DEPARTMENT OF TRANSPORTATION**

**TRAFFIC CONTROL PLAN - STAGE III
STA 102+00 TO 109+00**

F.A.I. RTE.	SECTION	COUNTY	TOTAL SHEETS	SHEET NO.
64	82-3HB-1	ST. CLAIR	208	113
CONTRACT NO. 76022				
FED. ROAD DIST. NO. 8 ILLINOIS FED. AID PROJECT				

SCALE: SHEET NO. 7 OF 14 SHEETS STA. TO STA.

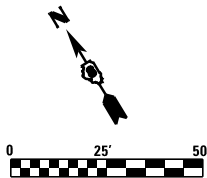

LEGEND

- WORK ZONE
- TRAFFIC FLOW ARROW
- TEMPORARY CONCRETE BARRIER
- TYPE II BARRICADES

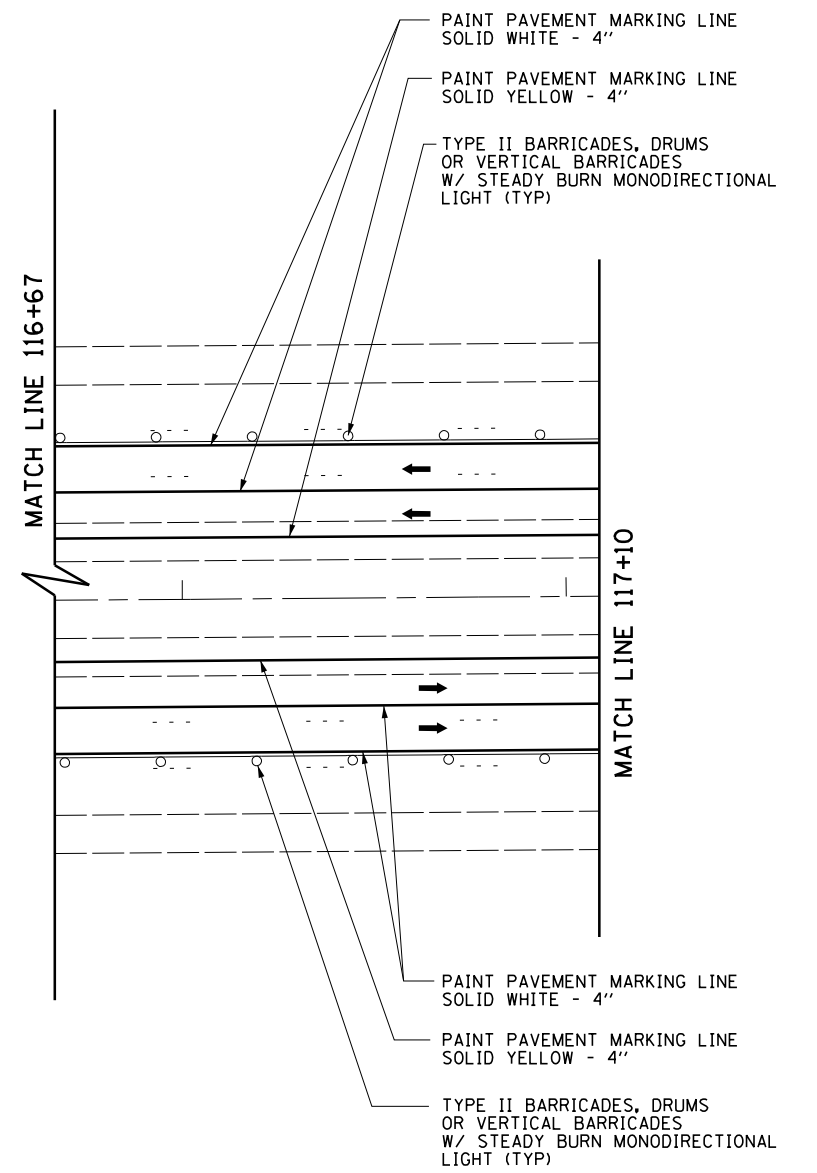
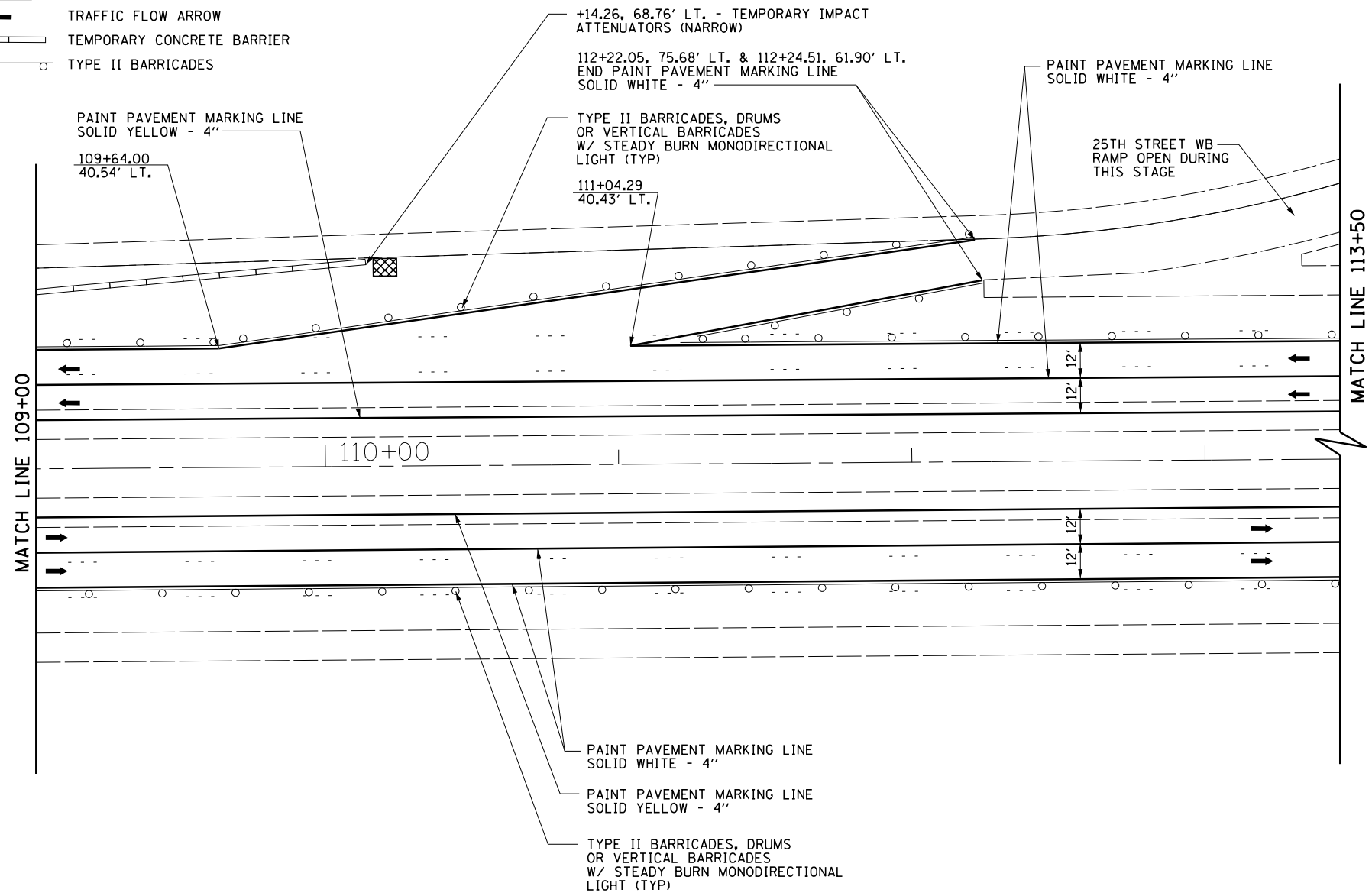

FILE NAME =	USER NAME = \$USER\$	DESIGNED - MBH	REVISED -
P:\10E2166-2\Design\Plans\0876022-sh-t-trafficcontrol-D.dgn		CHECKED - SJH	REVISED -
PLOT SCALE = 50.0000' / in.		DRAWN - MBH	REVISED -
PLOT DATE = 8/14/2013		CHECKED - SJH	REVISED -

**STATE OF ILLINOIS
DEPARTMENT OF TRANSPORTATION**

**TRAFFIC CONTROL PLAN - STAGE III
STA 109+00 TO 117+10**

SCALE: SHEET NO. 8 OF 14 SHEETS STA. TO STA.

F.A.I. RTE.	SECTION	COUNTY	TOTAL SHEETS	SHEET NO.
64	82-3HB-1	ST. CLAIR	208	114
CONTRACT NO. 76022				
FED. ROAD DIST. NO. 8 ILLINOIS FED. AID PROJECT				

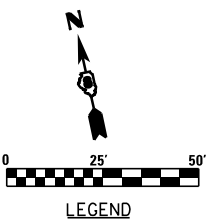
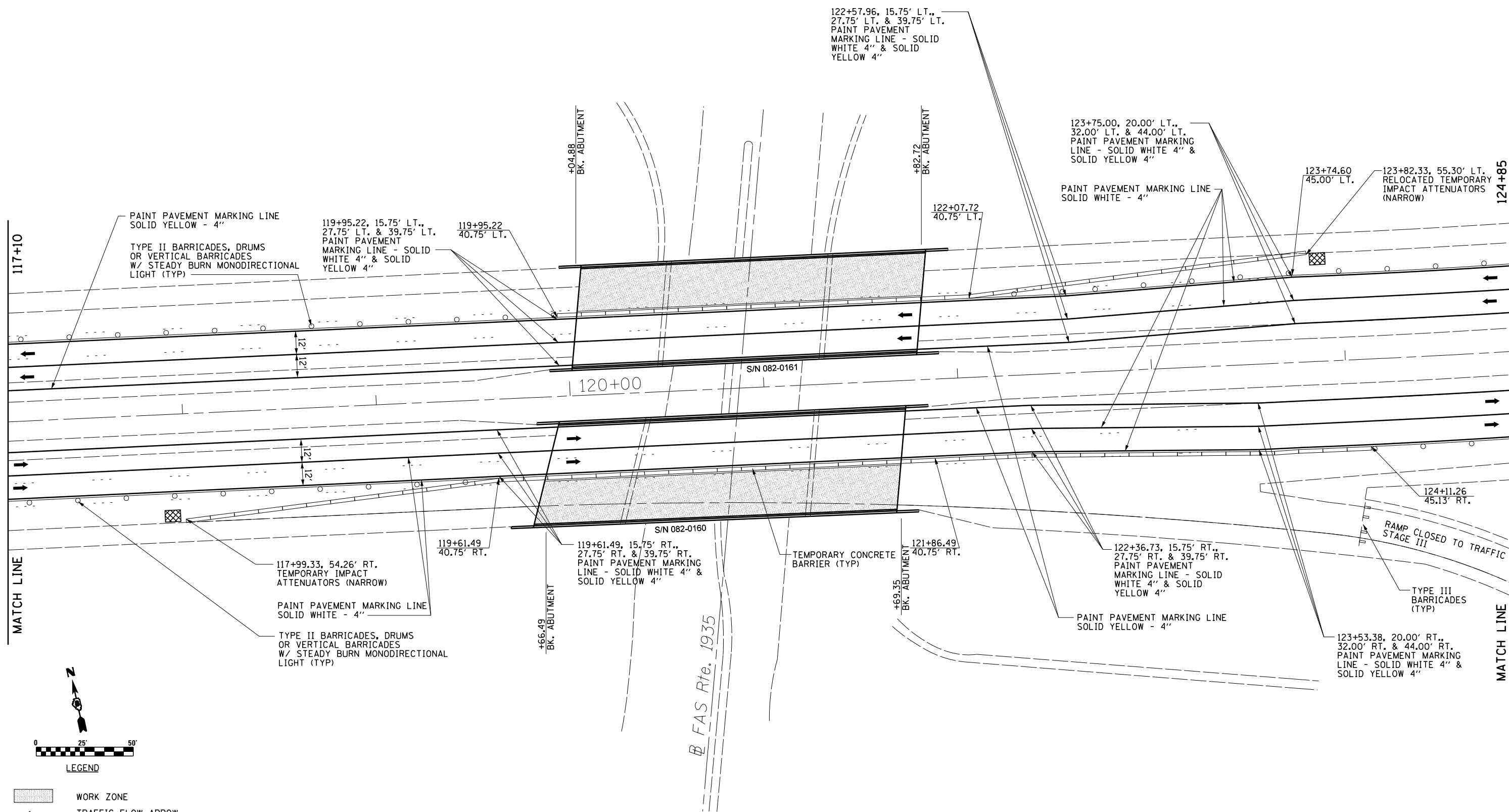

- WORK ZONE
- TRAFFIC FLOW ARROW
- TEMPORARY CONCRETE BARRIER
- TYPE II BARRICADES

FILE NAME =	USER NAME = \$USER\$	DESIGNED - MBH	REVISED -
P:\10E2166-2\Design\Plans\0876022-sh-t-trafficcontrol-DI.dgn		CHECKED - SJH	REVISED -
	PLOT SCALE = 50.0000' / in.	DRAWN - MBH	REVISED -
	PLOT DATE = 8/14/2013	CHECKED - SJH	REVISED -

**STATE OF ILLINOIS
DEPARTMENT OF TRANSPORTATION**

TRAFFIC CONTROL PLAN - STAGE III			
STA 117+10 TO 124+85			
SCALE:	SHEET NO. 9 OF 14 SHEETS	STA.	TO STA.

F.A.I. RTE.	SECTION	COUNTY	TOTAL SHEETS	SHEET NO.
64	82-3HB-1	ST. CLAIR	208	115
CONTRACT NO. 76022				
FED. ROAD DIST. NO. 8 ILLINOIS FED. AID PROJECT				

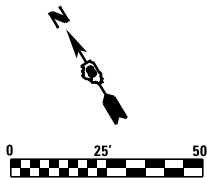

LEGEND

- WORK ZONE
- TRAFFIC FLOW ARROW
- TEMPORARY CONCRETE BARRIER
- TYPE II BARRICADES

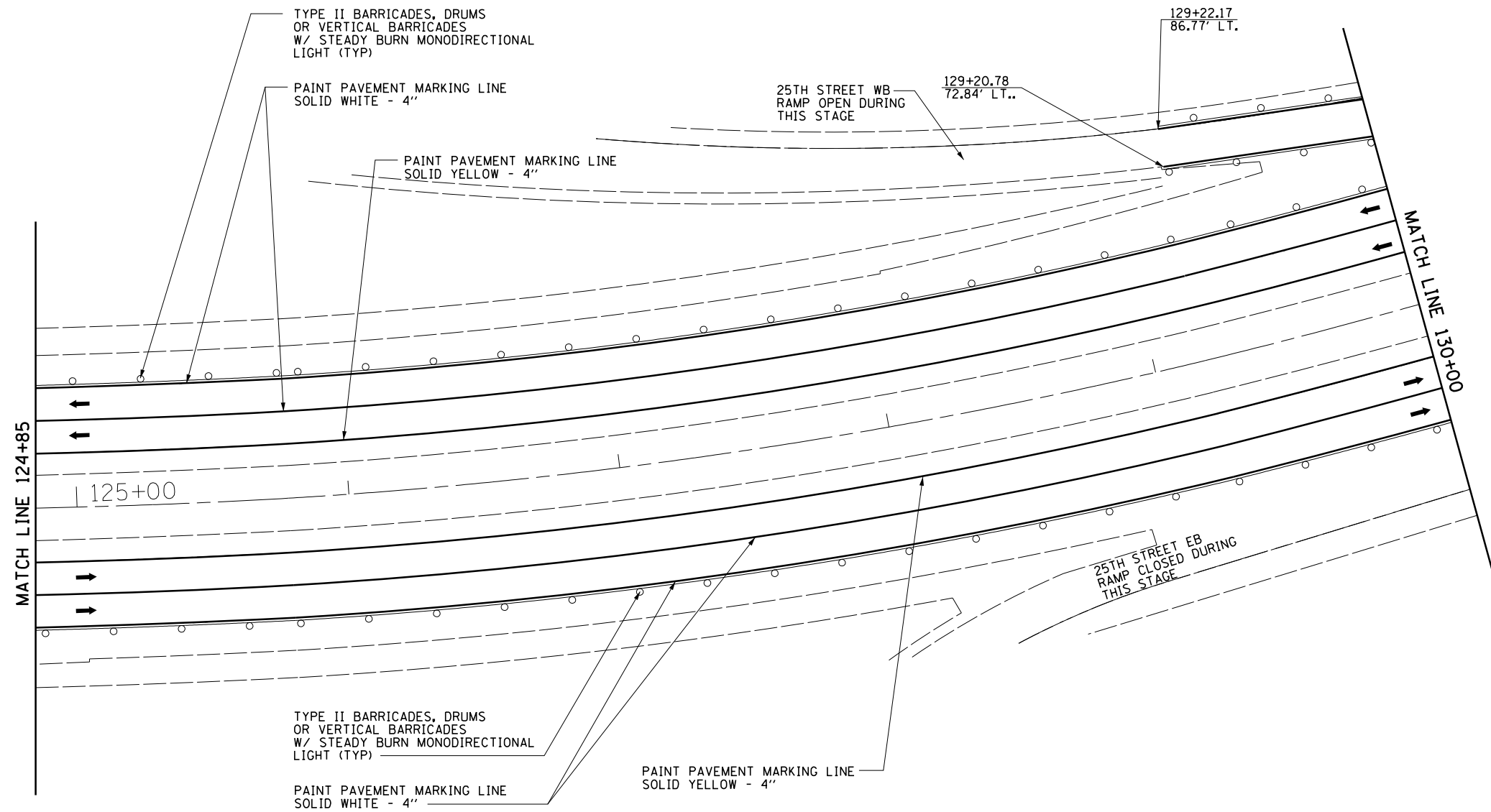

FILE NAME =	USER NAME = \$USER\$	DESIGNED - MBH	REVISED -
P:\10E2166-2\Design\Plans\0876022-sh-t-trafficcontrol-E.dgn		CHECKED - SJH	REVISED -
	PLOT SCALE = 50.0000' / in.	DRAWN - MBH	REVISED -
	PLOT DATE = 8/14/2013	CHECKED - SJH	REVISED -

**STATE OF ILLINOIS
DEPARTMENT OF TRANSPORTATION**

**TRAFFIC CONTROL PLAN - STAGE III
STA 124+85 TO 130+00**

SCALE: SHEET NO. 10 OF 14 SHEETS STA. TO STA.

F.A.I. RTE.	SECTION	COUNTY	TOTAL SHEETS	SHEET NO.
64	82-3HB-1	ST. CLAIR	208	116
CONTRACT NO. 76022				
<small>FED. ROAD DIST. NO. 8 ILLINOIS FED. AID PROJECT</small>				

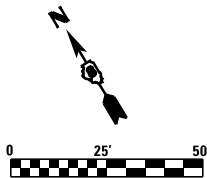

LEGEND

- WORK ZONE
- TRAFFIC FLOW ARROW
- TEMPORARY CONCRETE BARRIER
- TYPE II BARRICADES

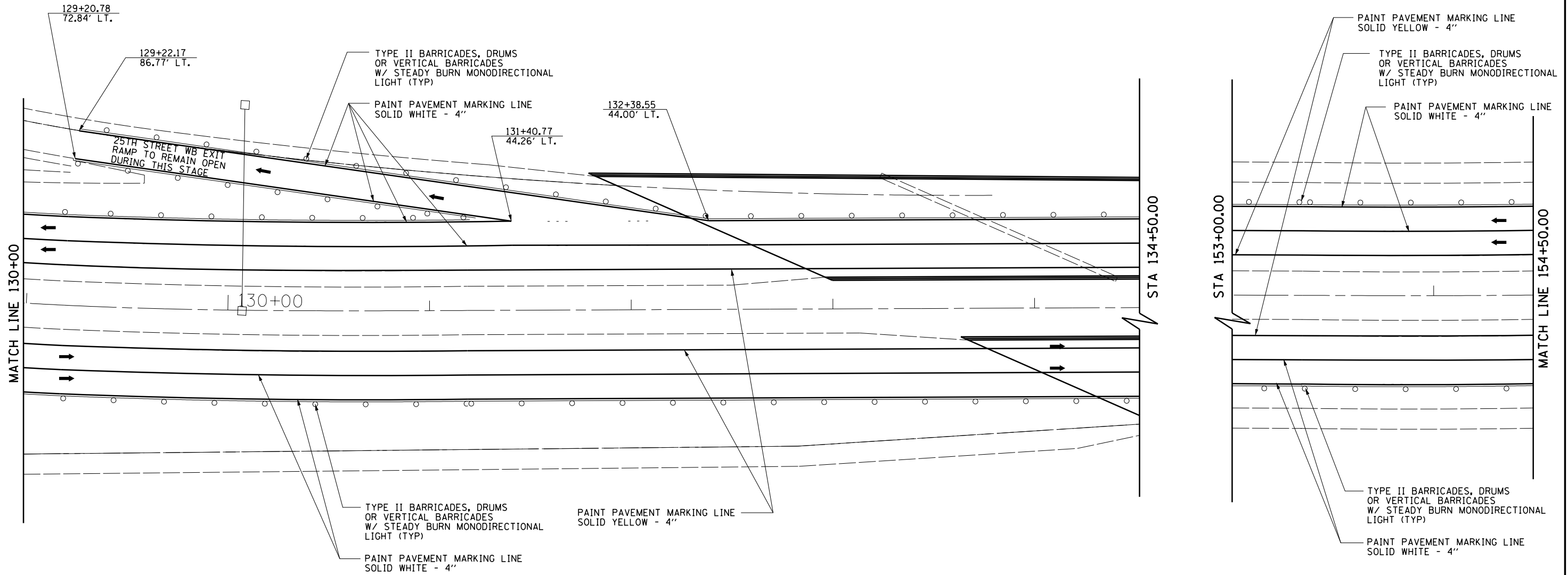

FILE NAME =	USER NAME = \$USER\$	DESIGNED - MBH	REVISED -
P:\10E2166-2\Design\Plans\0876022-sh-t-trafficcontrol-F.dgn		CHECKED - SJH	REVISED -
	PLOT SCALE = 50.0000' / in.	DRAWN - MBH	REVISED -
	PLOT DATE = 8/14/2013	CHECKED - SJH	REVISED -

**STATE OF ILLINOIS
DEPARTMENT OF TRANSPORTATION**

**TRAFFIC CONTROL PLAN - STAGE III
STA 130+00 TO 154+50**

SCALE: SHEET NO. 11 OF 14 SHEETS STA. TO STA.

F.A.I. RTE.	SECTION	COUNTY	TOTAL SHEETS	SHEET NO.
64	82-3HB-1	ST. CLAIR	208	117
CONTRACT NO. 76022				
FED. ROAD DIST. NO. 8 ILLINOIS FED. AID PROJECT				



LEGEND

- WORK ZONE
- TRAFFIC FLOW ARROW
- TEMPORARY CONCRETE BARRIER
- TYPE II BARRICADES

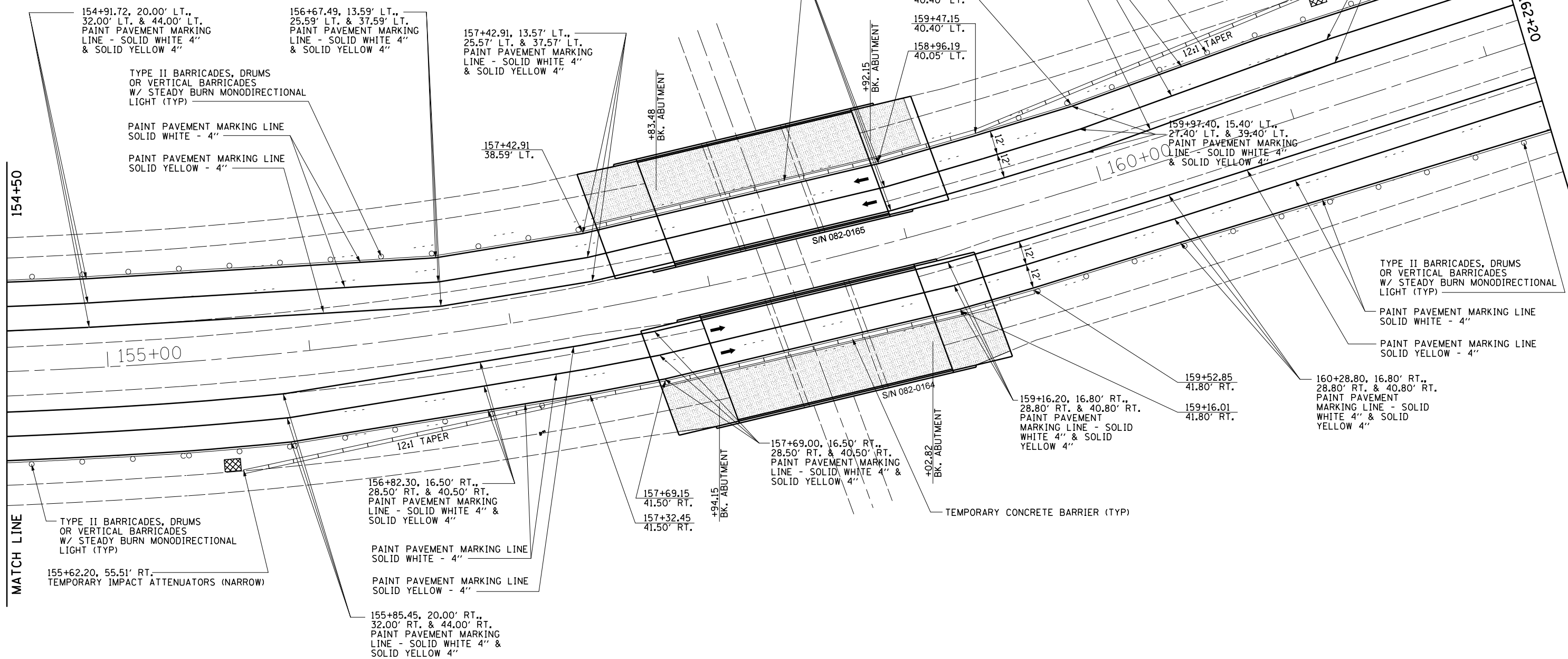

FILE NAME =	USER NAME = \$USER\$	DESIGNED - MBH	REVISED -
P:\10E2166-2\Design\Plans\0876022-sh-t-trafficcontrol-F1.dgn		CHECKED - SJH	REVISED -
	PLOT SCALE = 50.0000' / in.	DRAWN - MBH	REVISED -
	PLOT DATE = 8/14/2013	CHECKED - SJH	REVISED -

**STATE OF ILLINOIS
DEPARTMENT OF TRANSPORTATION**

**TRAFFIC CONTROL PLAN - STAGE III
STA 154+50 TO 162+20**

SCALE: SHEET NO. 12 OF 14 SHEETS STA. TO STA.

F.A.I. RTE.	SECTION	COUNTY	TOTAL SHEETS	SHEET NO.
64	82-3HB-1	ST. CLAIR	208	118
CONTRACT NO. 76D22				
FED. ROAD DIST. NO. 8 ILLINOIS FED. AID PROJECT				

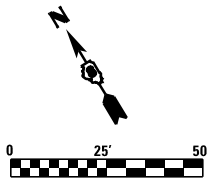

LEGEND

- WORK ZONE
- TRAFFIC FLOW ARROW
- TEMPORARY CONCRETE BARRIER
- TYPE II BARRICADES

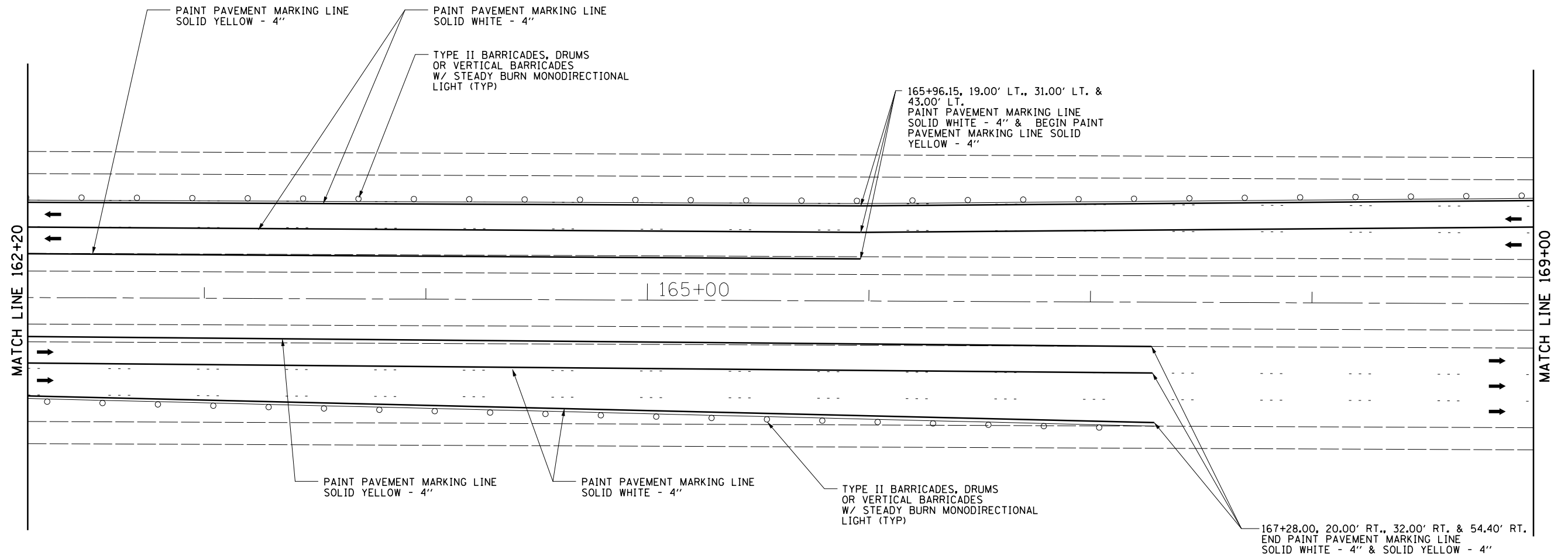

FILE NAME =	USER NAME = \$USER\$	DESIGNED - MBH	REVISED -
P:\10E2166-2\Design\Plans\0876022-sh-t-trafficcontrol-G.dgn		CHECKED - SJH	REVISED -
	PLOT SCALE = 50.0000' / in.	DRAWN - MBH	REVISED -
	PLOT DATE = 8/14/2013	CHECKED - SJH	REVISED -

STATE OF ILLINOIS
DEPARTMENT OF TRANSPORTATION

TRAFFIC CONTROL PLAN - STAGE III
STA 162+20 TO 169+00

SCALE: SHEET NO. 13 OF 14 SHEETS STA. TO STA.

F.A.I. RTE.	SECTION	COUNTY	TOTAL SHEETS	SHEET NO.
64	82-3HB-1	ST. CLAIR	208	119
CONTRACT NO. 76022				
FED. ROAD DIST. NO. 8 ILLINOIS FED. AID PROJECT				

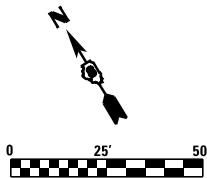

LEGEND

- WORK ZONE
- TRAFFIC FLOW ARROW
- TEMPORARY CONCRETE BARRIER
- TYPE II BARRICADES

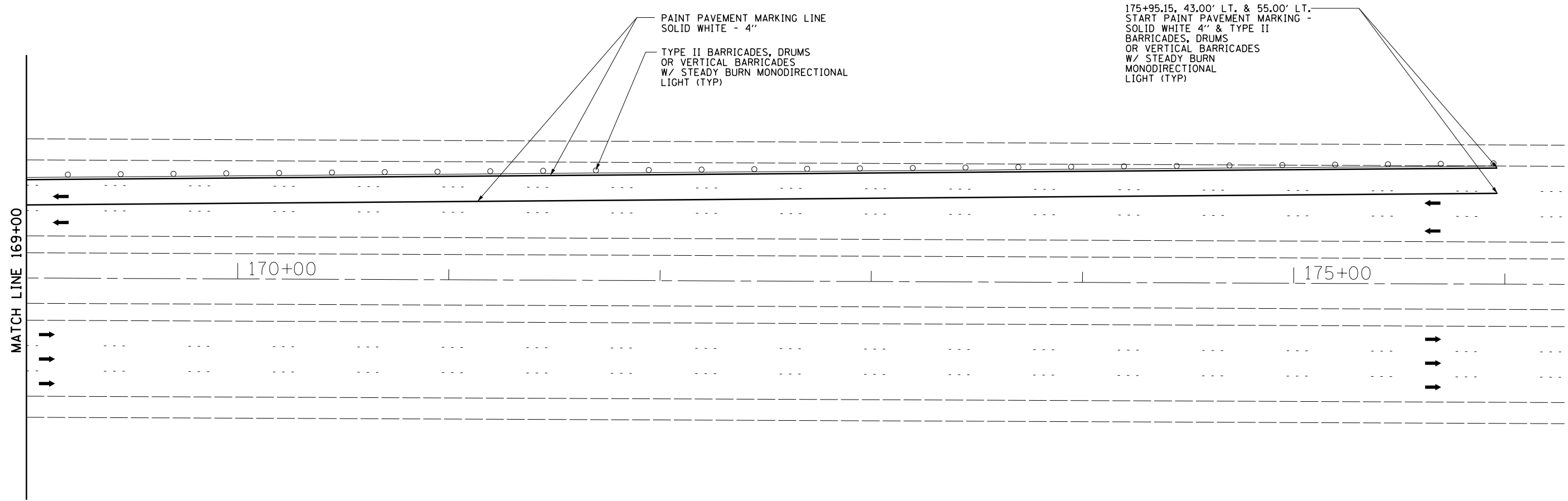

**STATE OF ILLINOIS
DEPARTMENT OF TRANSPORTATION**

**TRAFFIC CONTROL PLAN - STAGE III
STA 169+00 TO 176+00**

FILE NAME =	USER NAME = \$USER\$	DESIGNED - MBH	REVISED -
P:\10E2166-2\Design\Plans\0876022-sh-t-trafficcontrol-H.dgn		CHECKED - SJH	REVISED -
	PLOT SCALE = 50.0000' / in.	DRAWN - MBH	REVISED -
	PLOT DATE = 8/14/2013	CHECKED - SJH	REVISED -

SCALE: SHEET NO. 14 OF 14 SHEETS STA. TO STA.

F.A.I. RTE.	SECTION	COUNTY	TOTAL SHEETS	SHEET NO.
64	82-3HB-1	ST. CLAIR	208	120
CONTRACT NO. 76D22				
FED. ROAD DIST. NO. 8 ILLINOIS FED. AID PROJECT				

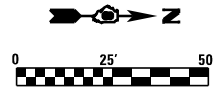

LEGEND

- WORK ZONE
- TRAFFIC FLOW ARROW
- TEMPORARY CONCRETE BARRIER
- TYPE II BARRICADES
- TYPE III BARRICADES

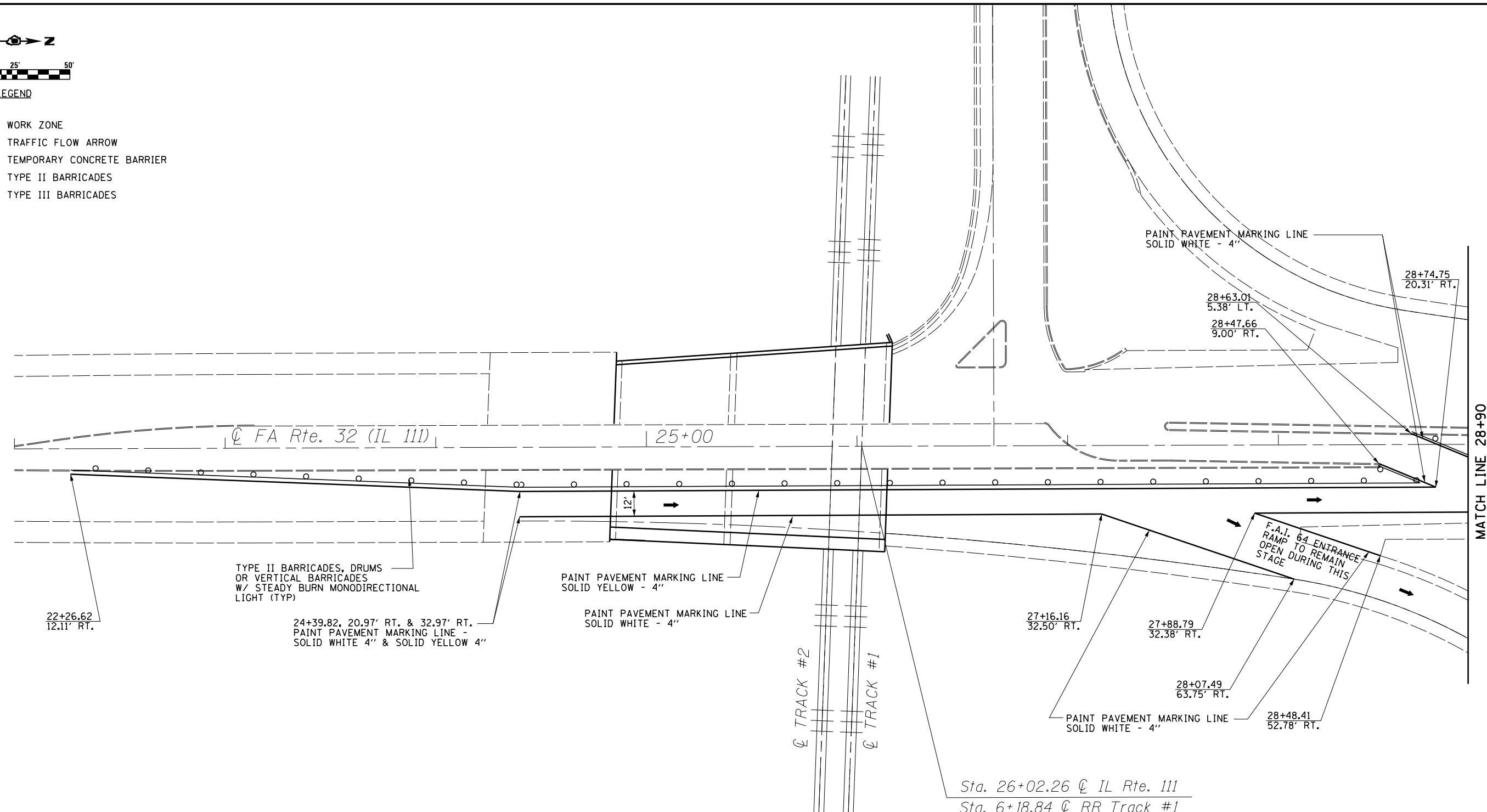

NOTES

- STANDARD 701411-08 SHALL BE USED FOR TRAFFIC CONTROL ON F.A.I. 64 ENTRANCE RAMP (ONE ON EACH BRIDGE QUADRANT) & ON TURN LANES AT STA 28+70 & 35+10.
- TRAFFIC CONTROL SIGNS SHALL BE PLACED ON BOTH THE LEFT AND RIGHT SIDE OF THE PAVEMENT.
- TEMPORARY CONCRETE BARRIER SHALL HAVE TWO (2) BARRIER WALL MARKERS PLACED ON TOP OF EACH OTHER, SEE DETAIL A. IN LOCATIONS WHERE THE GLARE SCREEN IS NOT PRESENT A BARRIER WALL MARKER SHALL BE USED ON THE TOP OF EACH TEMPORARY CONCRETE BARRIER. ALL BARRIER WALL MARKERS SHALL BE PLACED AT 25' CENTERS UNLESS OTHERWISE SPECIFIED BY THE ENGINEER. SEE STANDARD 704001-07. THESE ADDITIONAL BARRIER WALL MARKERS SHALL BE INCLUDED IN THE COST OF TEMPORARY CONCRETE BARRIER.
- ALL TRAFFIC CONTROL DEVICES SHALL BE IN ACCORDANCE WITH STANDARD 701901-02.
- STAGE I TRAFFIC CONTROL STANDARDS
 - 701411-08 - USE FOR SHOULDER AND LANE CLOSURE NEAR ENTRANCE/EXIT RAMP
 - 701606-08 - USE FOR APPROACH TO LANE CLOSURE AND FOR LANE CLOSURE (MODIFIED WITH BARRIER)
 - 701901-02 - USE FOR TRAFFIC CONTROL DEVICES
 - 704001-07 - USE FOR TEMPORARY CONCRETE BARRIER
 - 720001-01 & 720006-03 - USE FOR PROPOSED CONSTRUCTION SIGNS
 - 780001-03 - USE FOR STAGING PAVEMENT MARKINGS

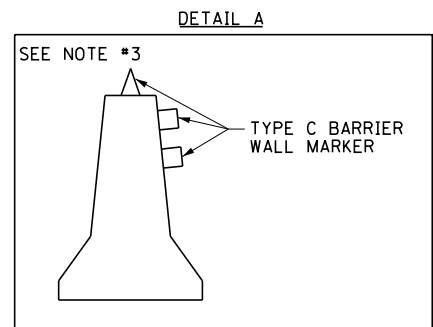

SUGGESTED STAGE I PROCEDURES

1. REMOVE EXISTING PAVEMENT MARKINGS & PLACE TRAFFIC CONTROL MARKINGS.
2. MOVE ALL TRAFFIC INTO STAGE I TRAFFIC LANE.
3. INSTALL TEMPORARY CONCRETE BARRIERS, TEMPORARY IMPACT ATTENUATORS AND TRAFFIC CONTROL DEVICES.
4. COMPLETE IMPROVEMENTS IN STAGE I WORK ZONE ON STRUCTURE

FILE NAME =	USER NAME = \$USER\$	DESIGNED - MBH	REVISED -	STATE OF ILLINOIS DEPARTMENT OF TRANSPORTATION	TRAFFIC CONTROL PLAN - STAGE I ILL RTE 111 - STA 22+00 TO 28+90	F.A.I. RTE. 64	SECTION 82-3HB-1	COUNTY ST. CLAIR	TOTAL SHEETS 208	SHEET NO. 121		
P:\10E2166-2\Design\Plans\0876022-sh1-trafficcontrol-J.dgn		CHECKED - SJH	REVISED -			SCALE:	SHEET NO. 1 OF 4 SHEETS	STA.	TO STA.	CONTRACT NO. 76D22		
		DRAWN - MBH	REVISED -			FED. ROAD DIST. NO. 8 ILLINOIS FED. AID PROJECT						
		CHECKED - SJH	REVISED -									

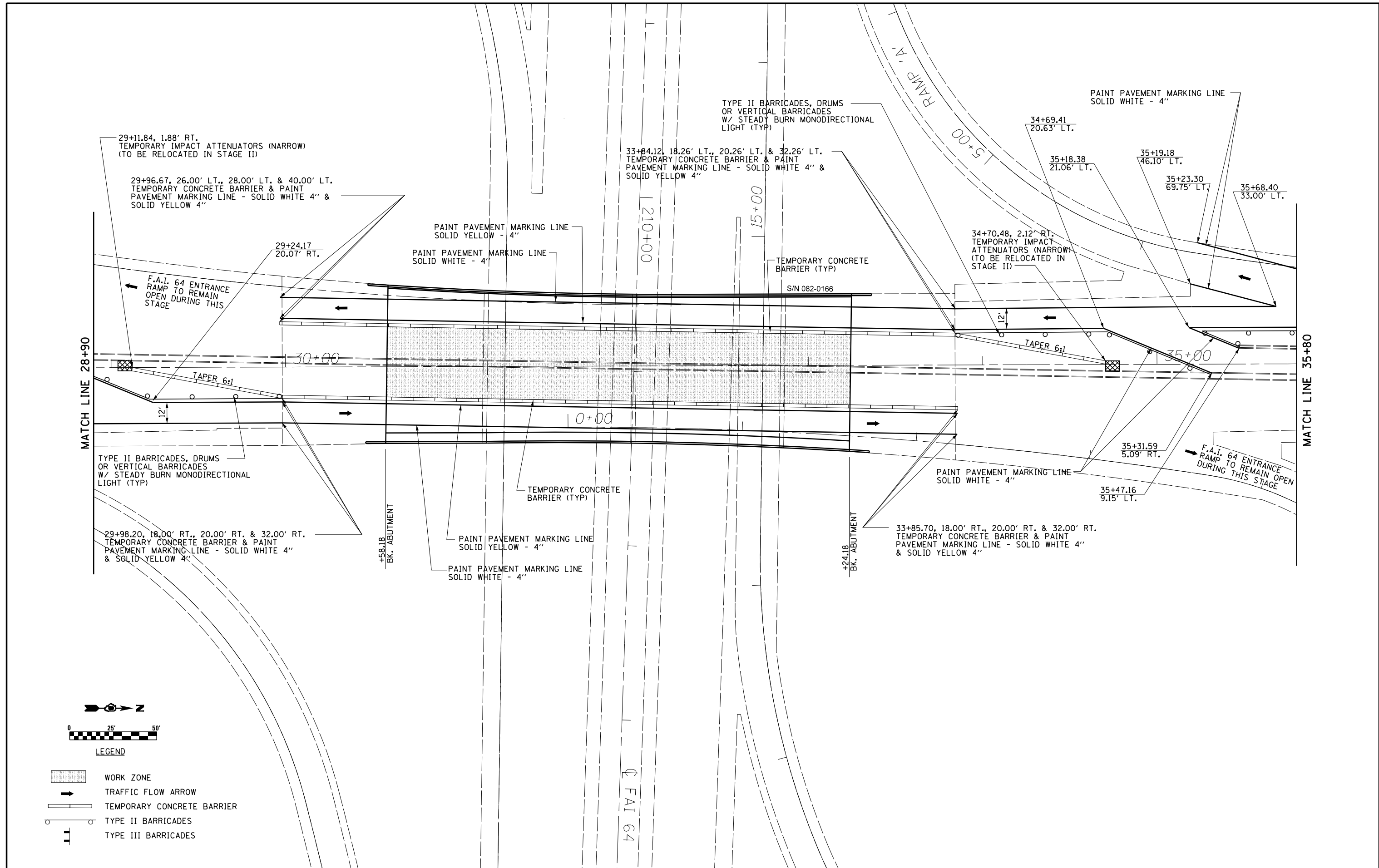

LEGEND

- WORK ZONE
- TRAFFIC FLOW ARROW
- TEMPORARY CONCRETE BARRIER
- TYPE II BARRICADES
- TYPE III BARRICADES

FILE NAME =	USER NAME = \$USER\$	DESIGNED - MBH	REVISED -	STATE OF ILLINOIS DEPARTMENT OF TRANSPORTATION	TRAFFIC CONTROL PLAN - STAGE I ILL RTE 111 - STA 28+90 TO 35+80			F.A.I. RTE. 64	SECTION 82-3HB-1	COUNTY ST. CLAIR	TOTAL SHEETS 208	SHEET NO. 122
		CHECKED - SJH	REVISED -		SCALE: SHEET NO. 2 OF 4 SHEETS STA. TO STA.			CONTRACT NO. 76D22				
		DRAWN - MBH	REVISED -		FED. ROAD DIST. NO. 8 ILLINOIS FED. AID PROJECT							
		CHECKED - SJH	REVISED -									

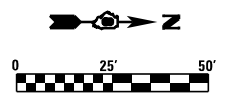

LEGEND

- WORK ZONE
- TRAFFIC FLOW ARROW
- TEMPORARY CONCRETE BARRIER
- TYPE II BARRICADES
- TYPE III BARRICADES

PI Sta. 8+52.19 @ CH 34
Sta. 0+00 @ Access Rd

Access Road 'A'

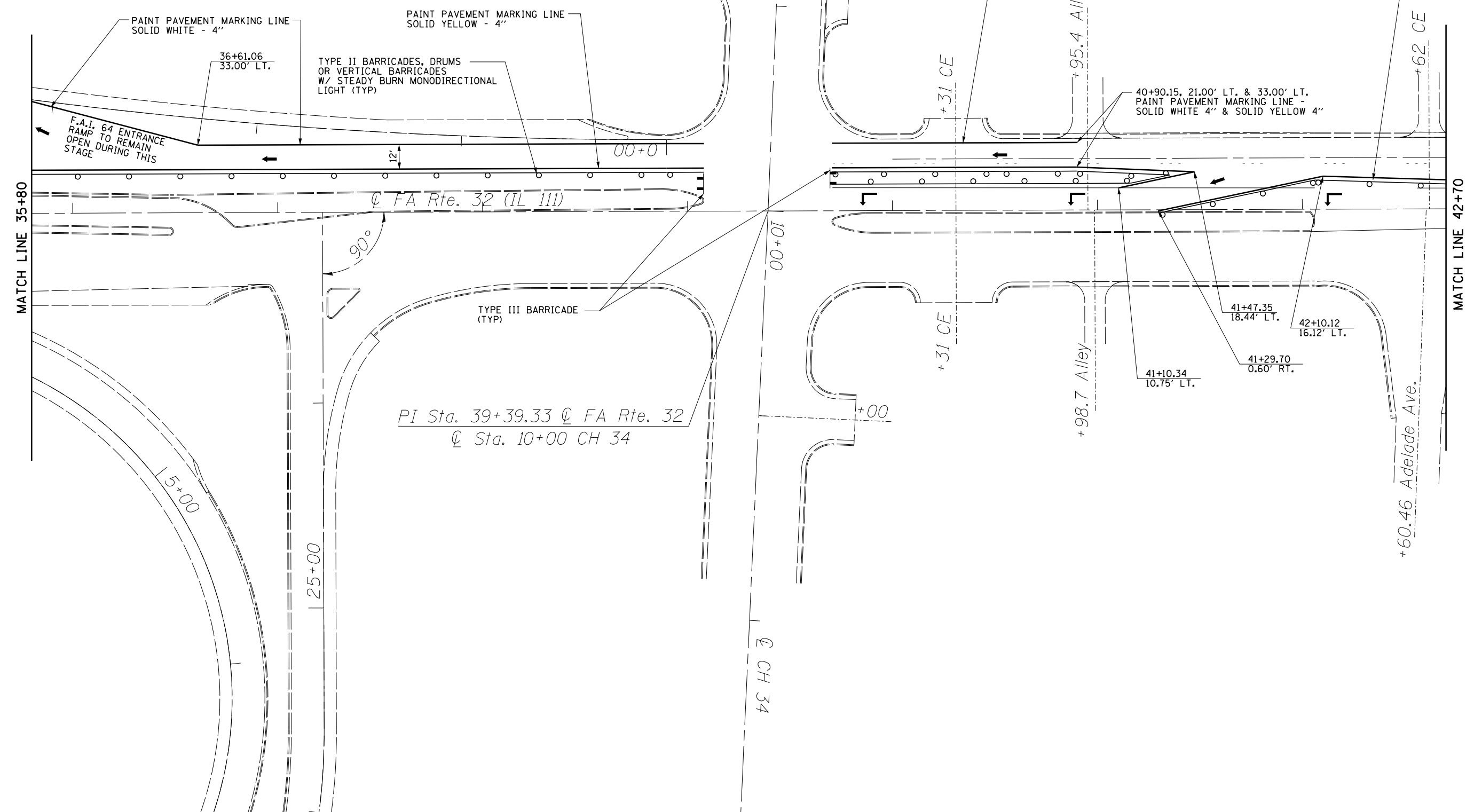

MATCH LINE 35+80

MATCH LINE 42+70

FILE NAME =	USER NAME = \$USER\$	DESIGNED - MBH	REVISED -
P:\10E2166-2\Design\Plans\0876022-sh-t-trafficcontrol-J.dgn		CHECKED - SJH	REVISED -
	PLOT SCALE = 50.0000' / in.	DRAWN - MBH	REVISED -
	PLOT DATE = 8/14/2013	CHECKED - SJH	REVISED -

**STATE OF ILLINOIS
DEPARTMENT OF TRANSPORTATION**



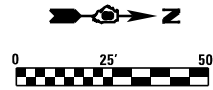

**TRAFFIC CONTROL PLAN - STAGE I
ILL RTE 111 - STA 35+80 TO 42+70**

SCALE: SHEET NO. 3 OF 4 SHEETS STA. TO STA.

F.A.I. RTE.	SECTION	COUNTY	TOTAL SHEETS	SHEET NO.
64	82-3HB-1	ST. CLAIR	208	123
CONTRACT NO. 76D22				
FED. ROAD DIST. NO. 8 ILLINOIS FED. AID PROJECT				



LEGEND

-  WORK ZONE
-  TRAFFIC FLOW ARROW
-  TEMPORARY CONCRETE BARRIER
-  TYPE II BARRICADES
-  TYPE III BARRICADES

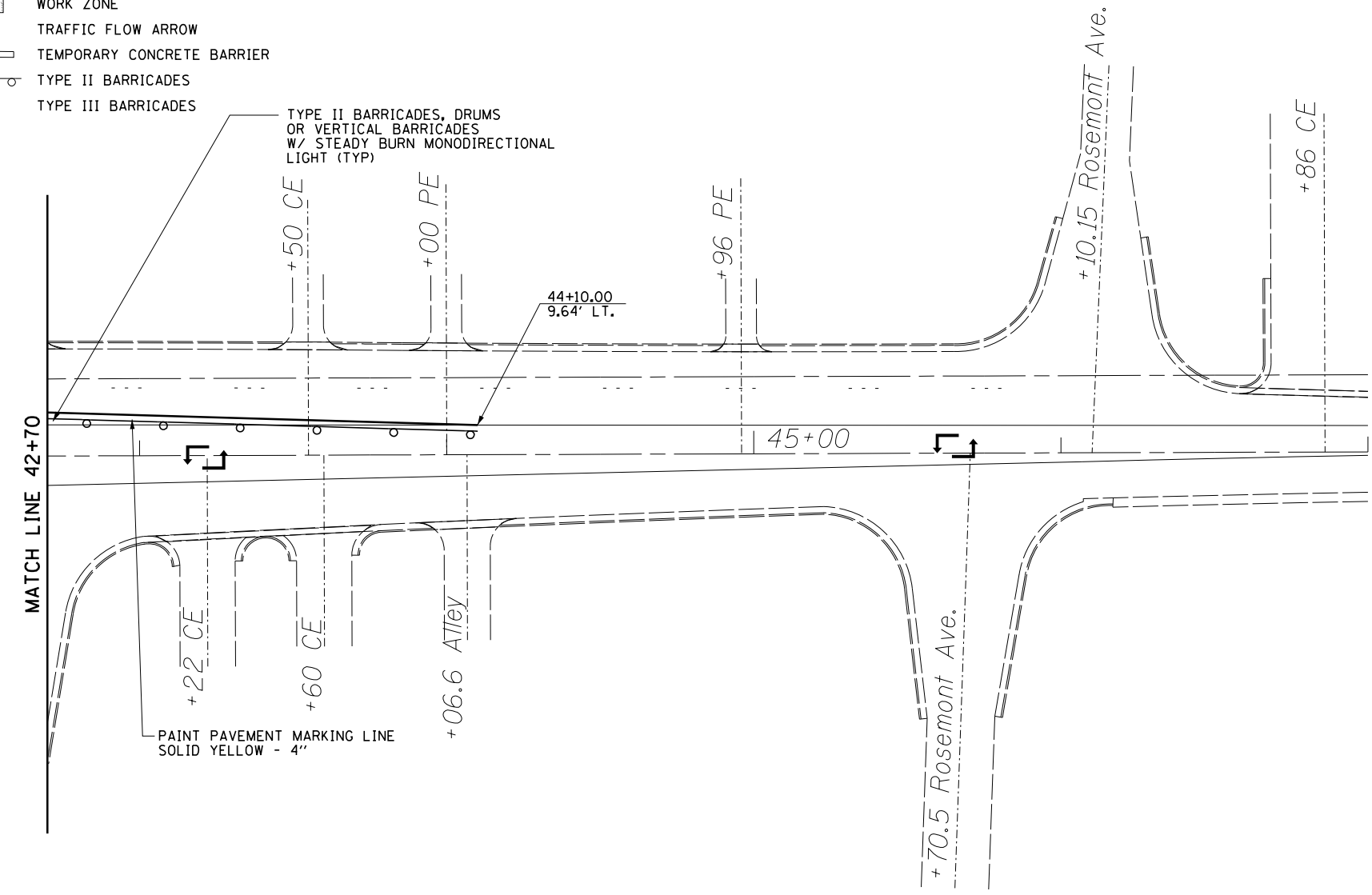

FILE NAME =	USER NAME = \$USER\$	DESIGNED - MBH	REVISED -
P:\10E2166-2\Design\Plans\0876022-sh-t-trafficcontrol-J.dgn		CHECKED - SJH	REVISED -
	PLOT SCALE = 50.0000' / in.	DRAWN - MBH	REVISED -
	PLOT DATE = 8/14/2013	CHECKED - SJH	REVISED -



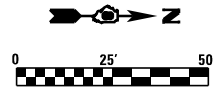

**STATE OF ILLINOIS
DEPARTMENT OF TRANSPORTATION**

TRAFFIC CONTROL PLAN - STAGE I			
ILL RTE 111 - STA 42+70 TO 47+00			
SCALE:	SHEET NO. 4 OF 4 SHEETS	STA.	TO STA.

F.A.I RTE.	SECTION	COUNTY	TOTAL SHEETS	SHEET NO.
64	82-3HB-1	ST. CLAIR	208	124
CONTRACT NO. 76022				
FED. ROAD DIST. NO. 8 ILLINOIS FED. AID PROJECT				



LEGEND

-  WORK ZONE
-  TRAFFIC FLOW ARROW
-  TEMPORARY CONCRETE BARRIER
-  TYPE II BARRICADES
-  TYPE III BARRICADES

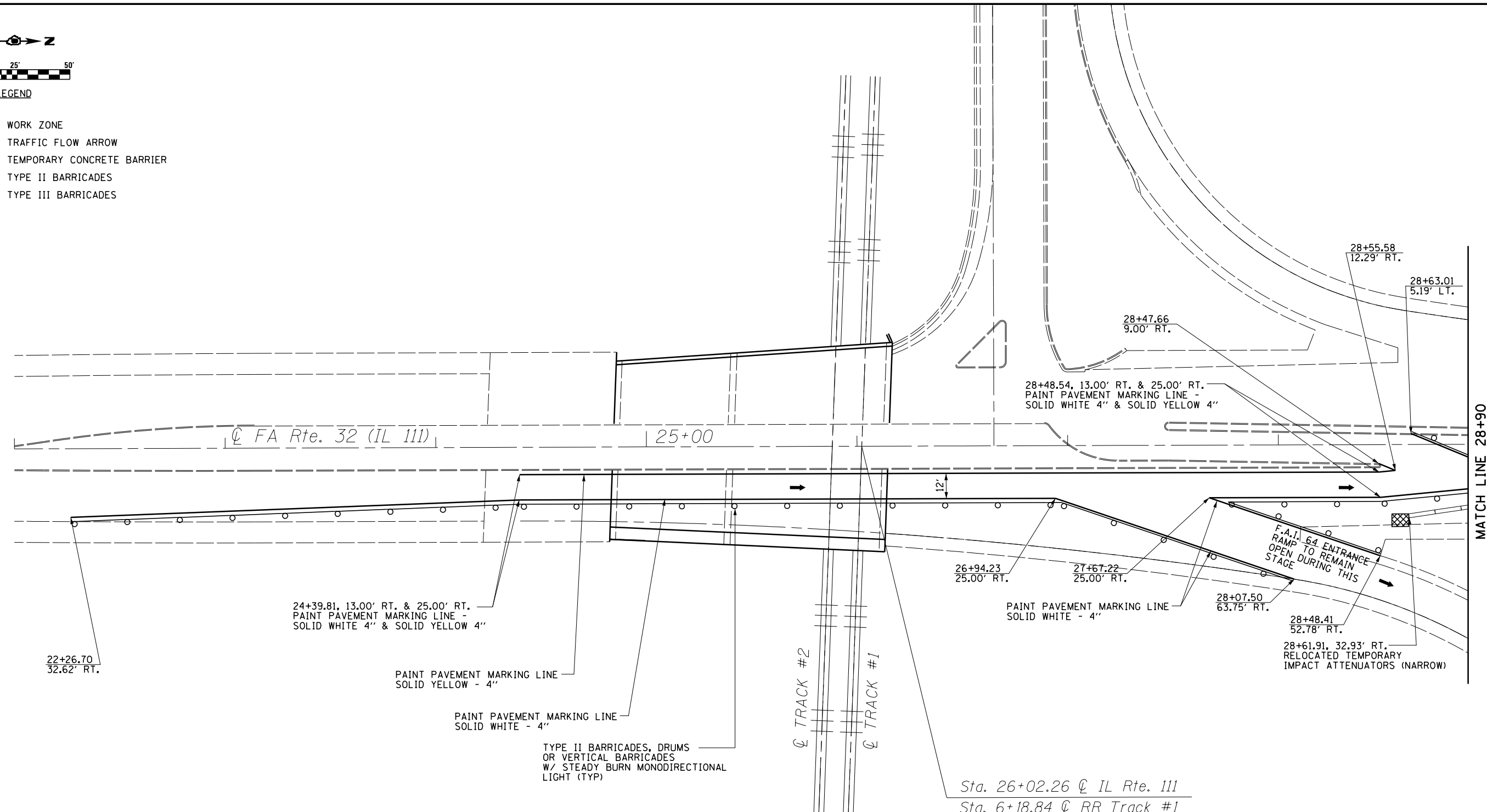

MATCH LINE 28+90

Sta. 26+02.26 @ IL Rte. 111
Sta. 6+18.84 @ RR Track #1

NOTES

STANDARD 701411-08 SHALL BE USED FOR TRAFFIC CONTROL ON F.A.I. 64 ENTRANCE RAMPS (ONE ON EACH BRIDGE QUADRANT) & ON TURN LANES AT STA 28+70 & 35+10.

TRAFFIC CONTROL SIGNS SHALL BE PLACED ON BOTH THE LEFT AND RIGHT SIDE OF THE PAVEMENT.

TEMPORARY CONCRETE BARRIER SHALL HAVE TWO (2) BARRIER WALL MARKERS PLACED ON TOP OF EACH OTHER, SEE DETAIL A. IN LOCATIONS WHERE THE GLARE SCREEN IS NOT PRESENT A BARRIER WALL MARKER SHALL BE USED ON THE TOP OF EACH TEMPORARY CONCRETE BARRIER. ALL BARRIER WALL MARKERS SHALL BE PLACED AT 25' CENTERS UNLESS OTHERWISE SPECIFIED BY THE ENGINEER. SEE STANDARD 704001-07. THESE ADDITIONAL BARRIER WALL MARKERS SHALL BE INCLUDED IN THE COST OF TEMPORARY CONCRETE BARRIER.

ALL TRAFFIC CONTROL DEVICES SHALL BE IN ACCORDANCE WITH STANDARD 701901-02.

STAGE I TRAFFIC CONTROL STANDARDS
 701411-08 - USE FOR SHOULDER AND LANE CLOSURE NEAR ENTRANCE/EXIT RAMP
 701606-08 - USE FOR APPROACH TO LANE CLOSURE AND FOR LANE CLOSURE (MODIFIED WITH BARRIER)
 701901-02 - USE FOR TRAFFIC CONTROL DEVICES
 704001-07 - USE FOR TEMPORARY CONCRETE BARRIER
 720001-01 & 720006-03 - USE FOR PROPOSED CONSTRUCTION SIGNS
 780001-03 - USE FOR STAGING PAVEMENT MARKINGS

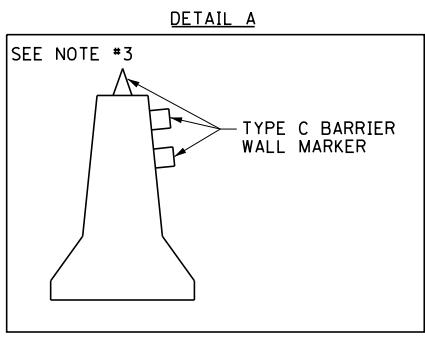

SUGGESTED STAGE II PROCEDURES

1. RELOCATE TEMPORARY CONCRETE BARRIERS, IMPACT ATTENUATORS, AND TRAFFIC CONTROL DEVICES AS REQUIRED.
2. MOVE ALL TRAFFIC TO STAGE II TRAFFIC LANE.
3. COMPLETE IMPROVEMENTS IN STAGE II WORK ZONE ON STRUCTURE

SUGGESTED FINAL STAGE PROCEDURES

1. REMOVE ALL TEMPORARY TRAFFIC BARRIERS AND CONTROL DEVICES.
2. INSTALL SHORT-TERM PAVEMENT MARKINGS.
3. OPEN ROADWAY TRAFFIC.
4. CONSTRUCT STRIPING ON ROADWAY TO MATCH EXISTING STRIPING.

FILE NAME =	USER NAME = \$USER\$	DESIGNED - MBH	REVISED -
P:\10E2166-2\Design\Plans\0876022-sh-t-trafficcontrol-J.dgn		CHECKED - SJH	REVISED -
	PLOT SCALE = 50.0000' / in.	DRAWN - MBH	REVISED -
	PLOT DATE = 8/14/2013	CHECKED - SJH	REVISED -

**STATE OF ILLINOIS
DEPARTMENT OF TRANSPORTATION**

**TRAFFIC CONTROL PLAN - STAGE II
ILL RTE 111 - STA 22+00 TO 28+90**

SCALE: SHEET NO. 1 OF 4 SHEETS STA. TO STA.

F.A.I. RTE.	SECTION	COUNTY	TOTAL SHEETS	SHEET NO.
64	82-3HB-1	ST. CLAIR	208	125
CONTRACT NO. 76D22				
FED. ROAD DIST. NO. 8 ILLINOIS FED. AID PROJECT				

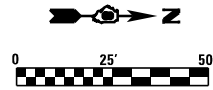

LEGEND

- WORK ZONE
- TRAFFIC FLOW ARROW
- TEMPORARY CONCRETE BARRIER
- TYPE II BARRICADES
- TYPE III BARRICADES

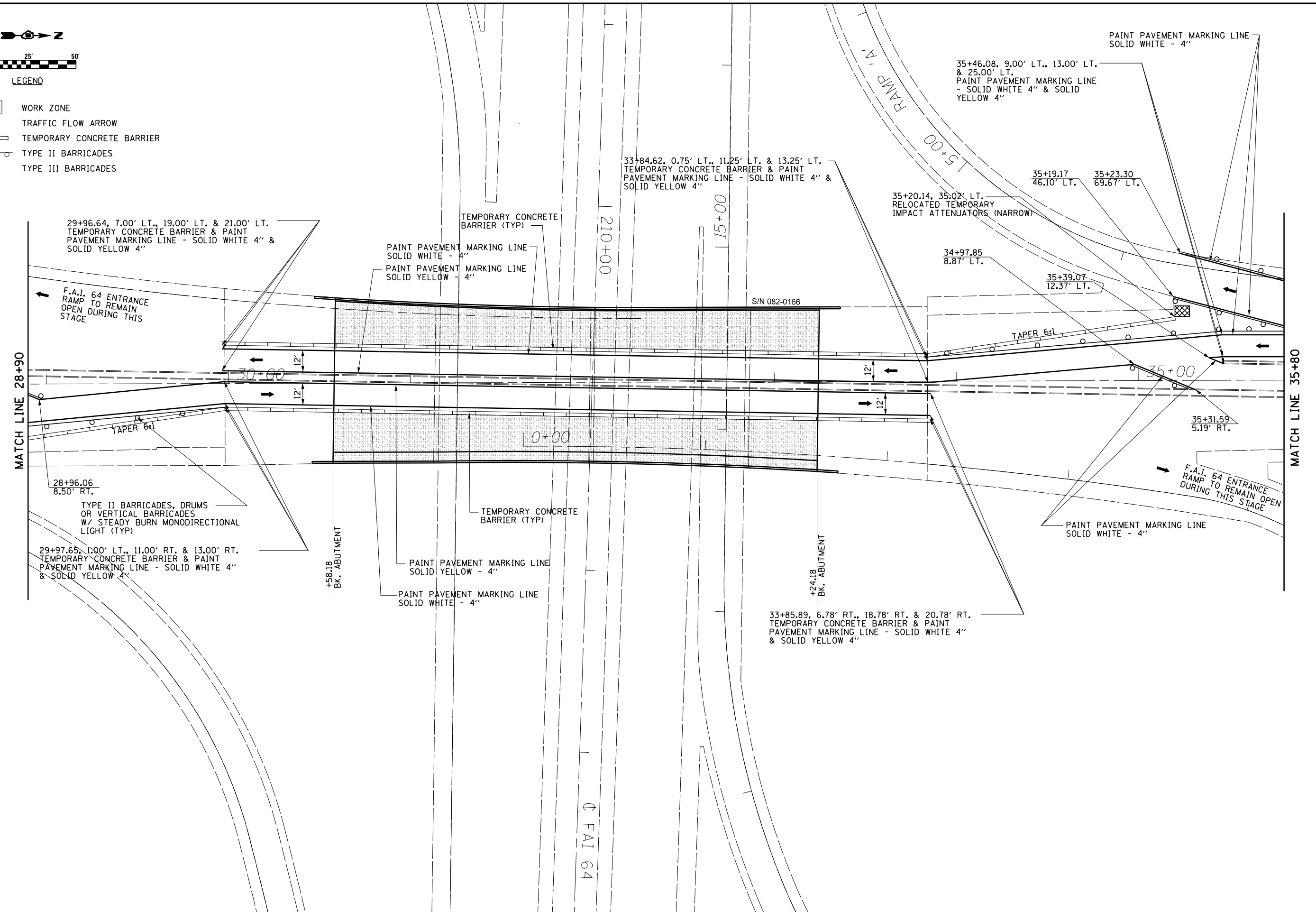

FILE NAME =	USER NAME = \$USER\$	DESIGNED - MBH	REVISED -
P:\10E2166-2\Design\Plans\0876022-sh-t-trafficcontrol-J.dgn		CHECKED - SJH	REVISED -
	PLOT SCALE = 50.0000' / in.	DRAWN - MBH	REVISED -
	PLOT DATE = 8/14/2013	CHECKED - SJH	REVISED -

**STATE OF ILLINOIS
DEPARTMENT OF TRANSPORTATION**

**TRAFFIC CONTROL PLAN - STAGE II
ILL RTE 111 - STA 28+90 TO 35+80**

SCALE: SHEET NO. 2 OF 4 SHEETS STA. TO STA.

F.A.I. RTE.	SECTION	COUNTY	TOTAL SHEETS	SHEET NO.
64	82-3HB-1	ST. CLAIR	208	126
CONTRACT NO. 76D22				
FED. ROAD DIST. NO. 8 ILLINOIS FED. AID PROJECT				

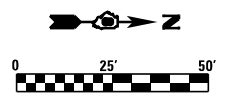

LEGEND

- WORK ZONE
- TRAFFIC FLOW ARROW
- TEMPORARY CONCRETE BARRIER
- TYPE II BARRICADES
- TYPE III BARRICADES

PI Sta. 8+52.19 @ CH 34
Sta. 0+00 @ Access Rd

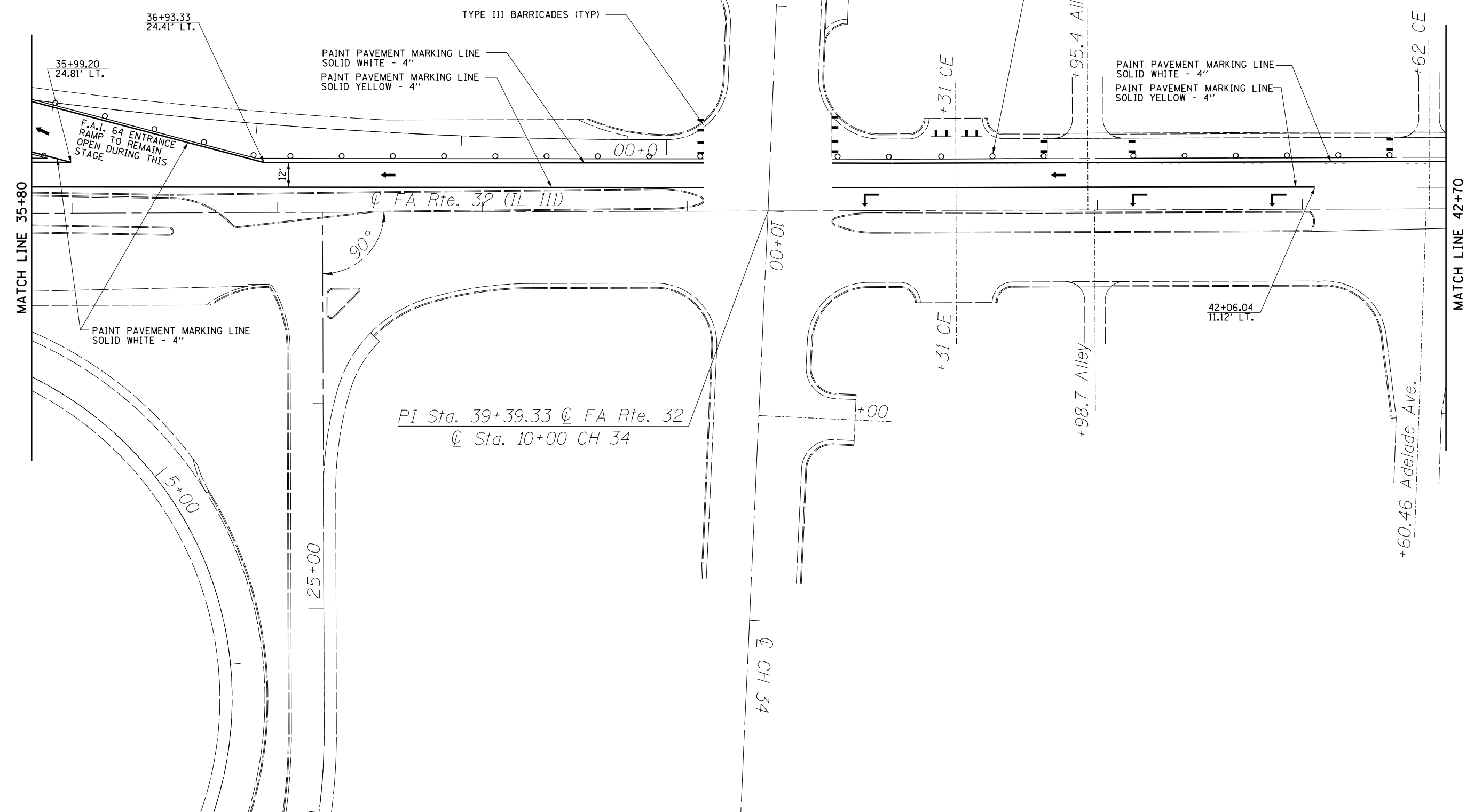

FILE NAME =	USER NAME = \$USER\$	DESIGNED - MBH	REVISED -
P:\10E2166-2\Design\Plans\0876022-sh-t-trafficcontrol-J.dgn		CHECKED - SJH	REVISED -
	PLOT SCALE = 50.0000' / in.	DRAWN - MBH	REVISED -
	PLOT DATE = 8/14/2013	CHECKED - SJH	REVISED -

**STATE OF ILLINOIS
DEPARTMENT OF TRANSPORTATION**

**TRAFFIC CONTROL PLAN - STAGE II
ILL RTE 111 - STA 35+80 TO 42+70**

SCALE: SHEET NO. 3 OF 4 SHEETS STA. TO STA.

F.A.I. RTE.	SECTION	COUNTY	TOTAL SHEETS	SHEET NO.
64	82-3HB-1	ST. CLAIR	208	127
CONTRACT NO. 76022				
FED. ROAD DIST. NO. 8 ILLINOIS FED. AID PROJECT				

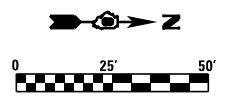

LEGEND

- WORK ZONE
- TRAFFIC FLOW ARROW
- TEMPORARY CONCRETE BARRIER
- TYPE II BARRICADES
- TYPE III BARRICADES

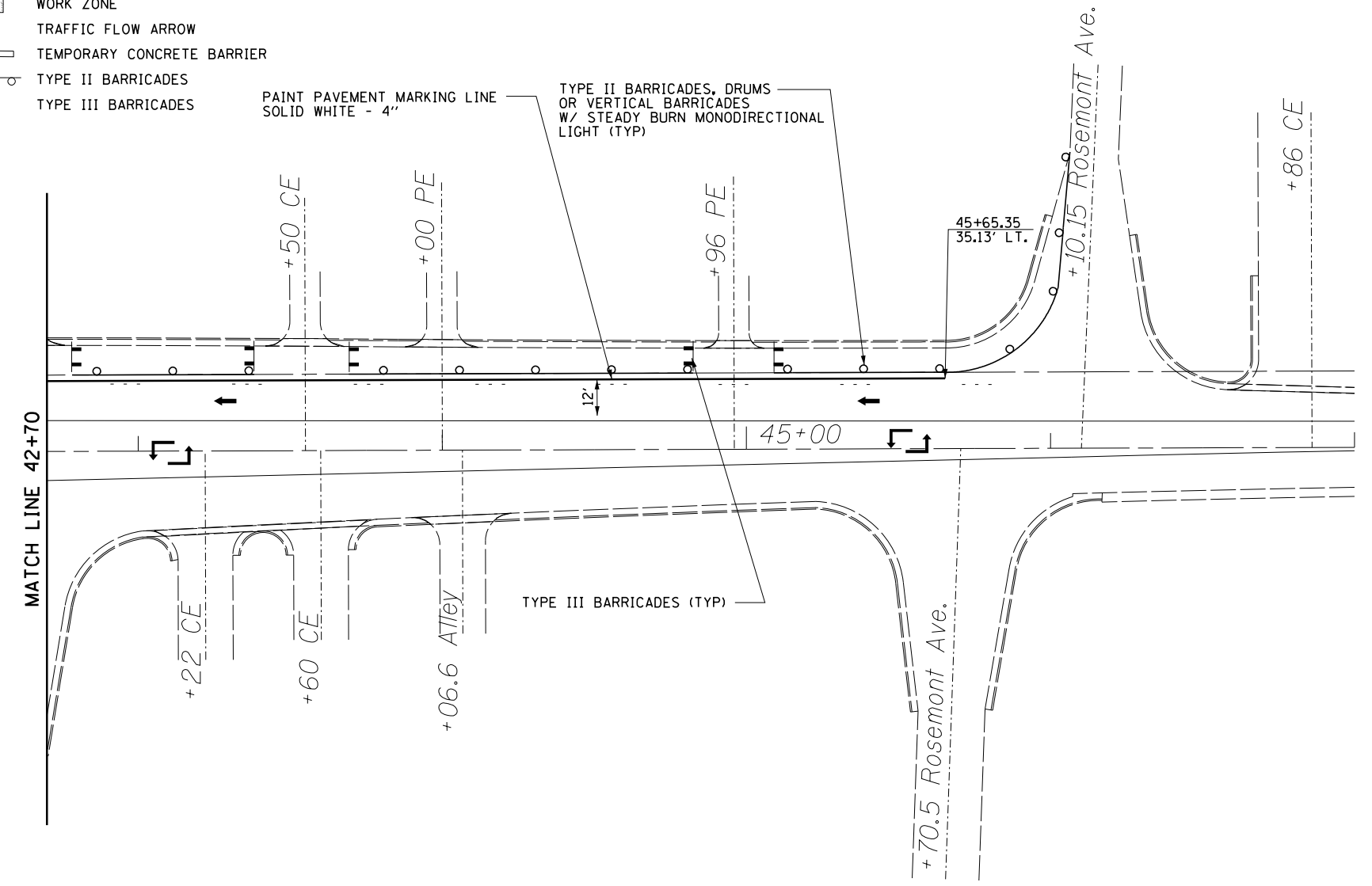

FILE NAME =	USER NAME = \$USER\$	DESIGNED - MBH	REVISED -
P:\10E2166-2\Design\Plans\0876022-sh-t-trafficcontrol-J.dgn	fficecontrol-J.dgn	CHECKED - SJH	REVISED -
	PLOT SCALE = 50.0000' / in.	DRAWN - MBH	REVISED -
	PLOT DATE = 8/14/2013	CHECKED - SJH	REVISED -

**STATE OF ILLINOIS
DEPARTMENT OF TRANSPORTATION**

TRAFFIC CONTROL PLAN - STAGE II ILL RTE 111 - STA 42+70 TO 47+00			
SCALE:	SHEET NO. 4 OF 4 SHEETS	STA.	TO STA.

F.A.I RTE.	SECTION	COUNTY	TOTAL SHEETS	SHEET NO.
64	82-3HB-1	ST. CLAIR	208	128
CONTRACT NO. 76D22				
FED. ROAD DIST. NO. 8 ILLINOIS FED. AID PROJECT				

INDEX OF SHEETS

General Plan & Elevation	1
Staging	2-3
Temporary Concrete Barrier For Stage Construction	4
Deck Repairs	5
Concrete Removal & Replacement	6-7
Preformed Joint Strip Seal	8
Bar Splicer Assembly Details	9

GENERAL NOTES

- All new structural steel shall conform to AASHTO Classification M270 Gr. 36 unless otherwise noted.
- Fasteners shall be AASHTO M164 Type I, mechanically galvanized bolts (in painted areas and M164 Type 3 in unpainted areas). Bolts $\frac{1}{8}$ " ϕ , holes $\frac{1}{16}$ " ϕ , unless otherwise noted.
- No field welding is permitted except as specified in the contract documents.
- Reinforcement bars designated (E) shall be epoxy coated.
- Prior to pouring the new concrete deck, all heavy or loose rust, loose mill scale, and other loose or potentially detrimental foreign material shall be removed from the surfaces in contact with concrete. Tightly adhered paint may remain unless otherwise noted. Removal shall be accomplished by methods that will not damage the steel and the cost will be included in the pay item covering removal of the existing concrete.

As directed by the Engineer, existing construction accessories welded to the top flange of beams and girders shall be removed. The weld areas shall be ground flush and inspected for cracks using magnetic particle testing (MT) or dye penetrant testing (PT) by qualified personnel approved by the Engineer. Any cracks that can not be removed by grinding $\frac{1}{4}$ in. deep shall be identified and reported to the Bureau of Bridges and Structures for further disposition. The cost of removing welded accessories, grinding and inspecting weld areas and grinding cracks will be paid for according to Article 109.04 of the Standard Specifications.

Plan dimensions and details relative to existing plans are subject to nominal construction variations. The Contractor shall field verify existing dimensions and details affecting new construction and make necessary approved adjustments prior to construction or ordering of materials. Such variations shall not be cause for additional compensation for a change in scope of the work, however, the Contractor will be paid for the quantity actually furnished at the unit price bid for the work.

Existing reinforcement bars extending into the removal area shall be cleaned, straightened and incorporated into the new construction. Any reinforcement bars that are damaged during concrete removal shall be replaced with an approved bar splicer or anchorage system. Cost included with Concrete Removal.

Joint openings shall be adjusted according to Article 520.04 of the Standard Specs. when the deck is poured at an ambient temperature other than 50° F.

Areas of deck repairs shown are estimated. The Engineer shall show actual locations of deck repairs on As-built Plans.

The existing structural steel contains lead. The contractor shall take appropriate precautions to deal with the presence of lead on this project.

All structural steel shall be shop painted with the inorganic zinc rich primer per AASHTO M300, Type I. Color to match existing. Cost included with Furnishing and Erecting Structural Steel.

Existing structural steel that will be in contact with new structural steel shall be cleaned and painted prior to erection as required by the Special Provisions "Cleaning & Painting Contact Surface Areas of Existing Steel Structures".

TOTAL BILL OF MATERIAL

ITEM	UNIT	QUANTITY
Concrete Removal	Cu. Yd.	30.1
Concrete Superstructure	Cu. Yd.	29.7
Bridge Deck Concrete Sealer	Sq. Ft.	18510
Furnishing and Erecting Structural Steel	Pound	2660
Reinforcement Bars, Epoxy Coated	Pound	4500
Preformed Joint Strip Seal	Foot	238
Anchor Bolts, 1"	Each	76
Deck Slab Repair (Full)	Sq. Yd.	3.4
Deck Slab Repair (Partial)	Sq. Yd.	3.4
Bar Splicers	Each	96
Protective Shield	Sq. Yd.	7

ORIGINAL DESIGN STRESSES

FIELD UNITS

$f'_c = 1,400$ psi (Piers and Superstructure)
 $f'_c = 1,000$ psi (Substructure w/ Earth Pressure)
 $f_y = 20,000$ psi (Reinforcement)
 $f_y = 20,000$ psi (Structural Steel A36)
 $n = 10$
 $N = 75$ psi

FAI 64 CURVE DATA

(Spiral Curve)

PI STA. = 88+63.12
 $\Delta = 30^\circ 24' 20''$
 $\Delta_c = 27^\circ 24' 20''$
 $D_c = 1^\circ 30' 0''$
 $R_c = 3,819.72'$
 $L_c = 1827.04'$
 $L_s = 200.00'$
 $\theta_s = 1^\circ 30' 0''$
 $T_s = 1138.11'$
 $E_s = 138.98'$
 $S.E. = 0.01'/FT.$

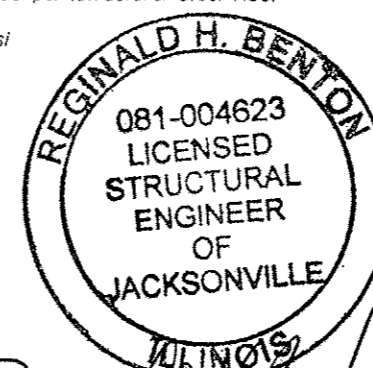

Reginald H. Benton
 10/3/13 EXP 11/30/14

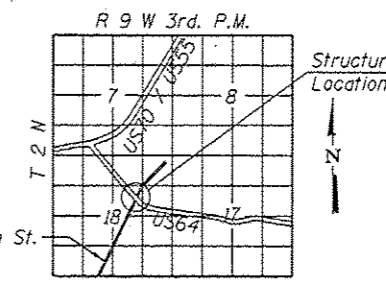

GENERAL PLAN & ELEVATION
INTERSTATE 64 OVER 18TH ST.
F.A.I. RTE. 64 - SEC. 82-1HBI-2
ST. CLAIR COUNTY
US 64 STA. 88+22.80
18TH ST. STA. 10+00.00

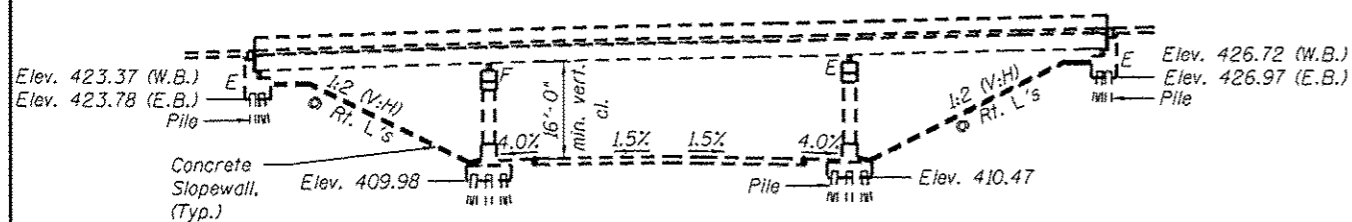

ELEVATION

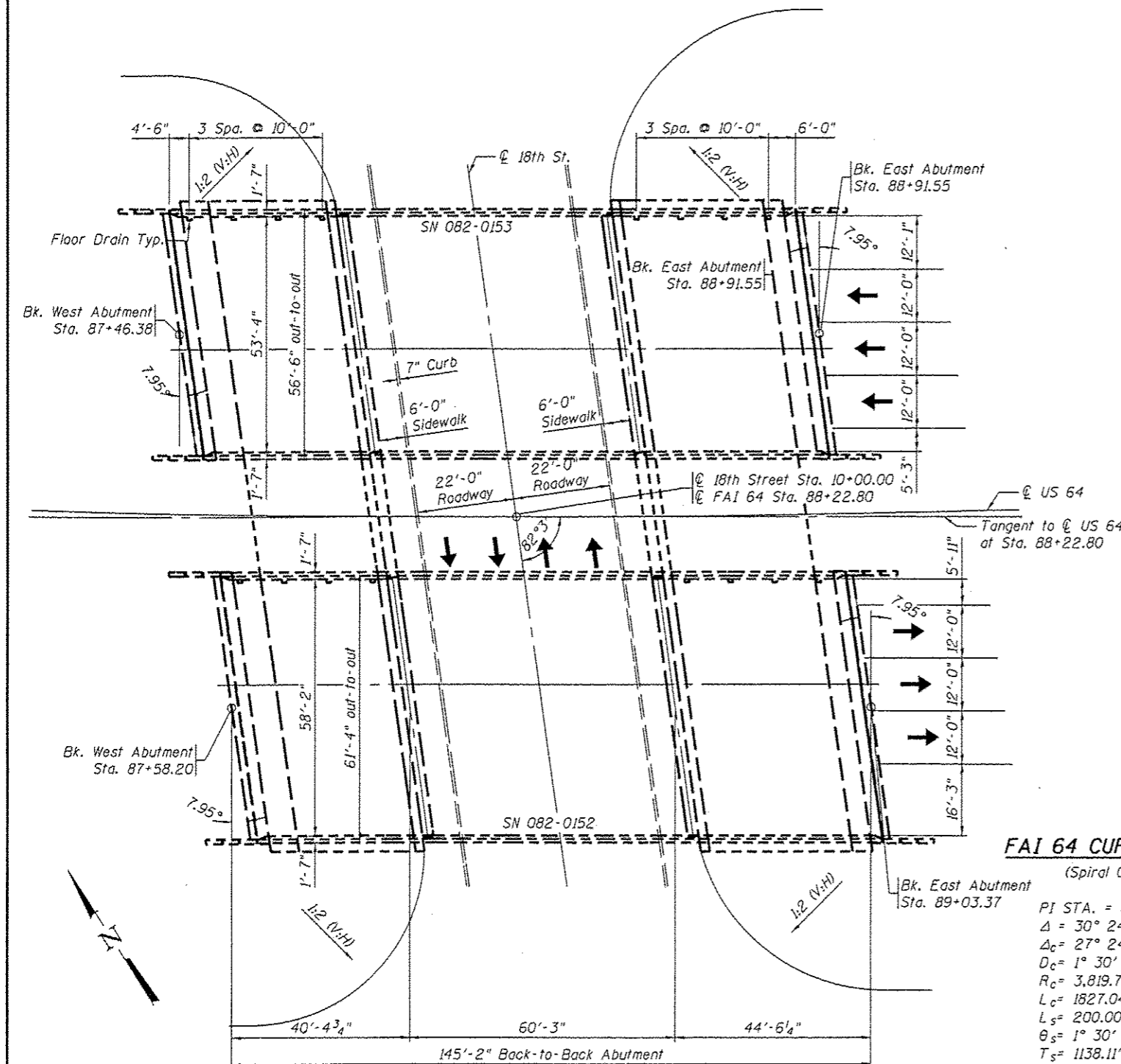

PLAN

BENTON & ASSOCIATES, INC.

FILE NAME = P:\10e2166-2\Design\	USER NAME =	DESIGNED - MBH	REVISED - 10/3/13
Plans\082-0152 & 082-0153		CHECKED - S.J.H.	REVISED -
0820152-76022-001-GPE.dgn		DRAWN - MBH	REVISED -
		CHECKED - S.J.H.	REVISED -

STATE OF ILLINOIS
DEPARTMENT OF TRANSPORTATION

GENERAL PLAN & ELEVATION
STRUCTURE NO. 082-0152 & 082-0153

SHEET NO. 1 OF 9 SHEETS

F.A.I. RTE.	SECTION	COUNTY	TOTAL SHEETS	SHEET NO.
64	82-1HBI-2	ST. CLAIR	208	129
CONTRACT NO. 76D22			FED. ROAD DIST. NO. 8 ILLINOIS FED. AID PROJECT	

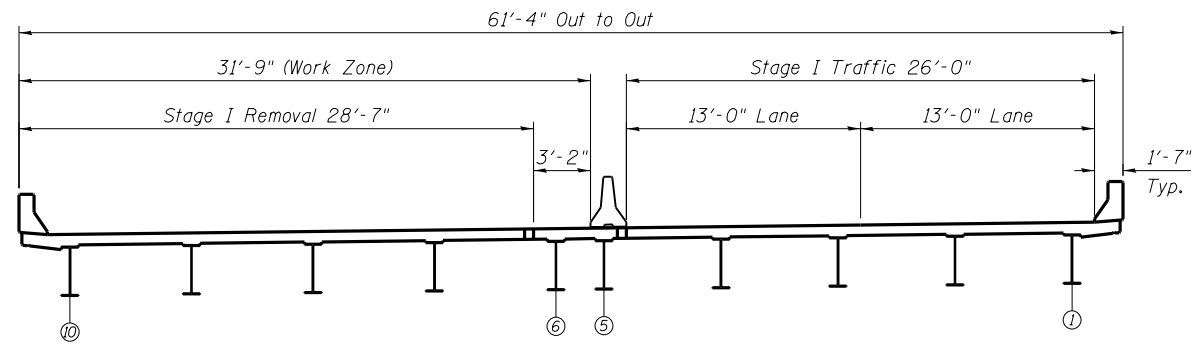

SN 082-0152 EASTBOUND CROSS SECTION
(Looking East)
STAGE I REMOVAL

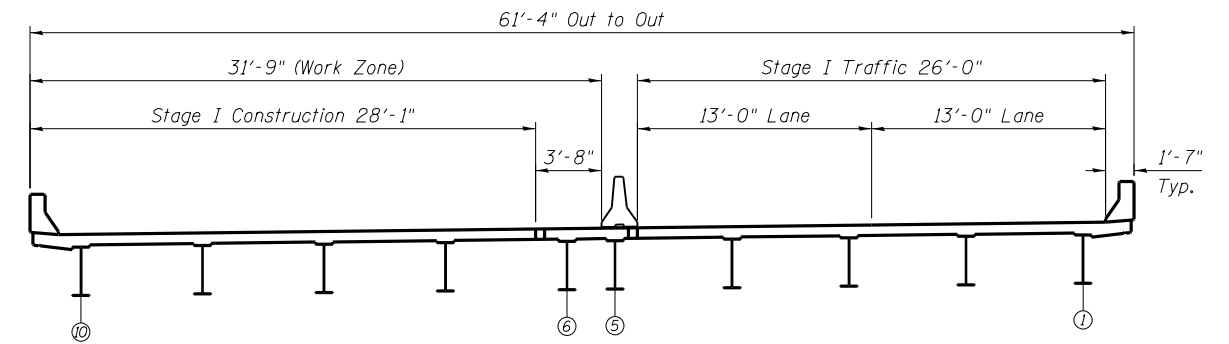

SN 082-0152 EASTBOUND CROSS SECTION
(Looking East)
STAGE I CONSTRUCTION

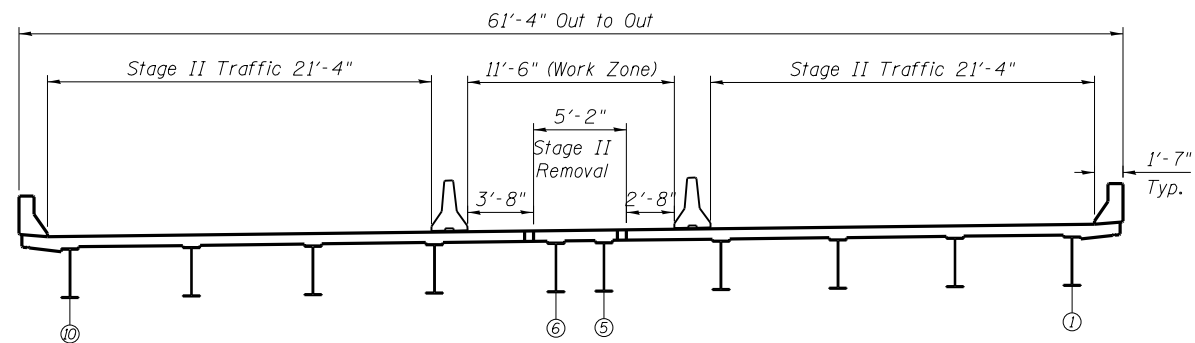

SN 082-0152 EASTBOUND CROSS SECTION
(Looking East)
STAGE II REMOVAL

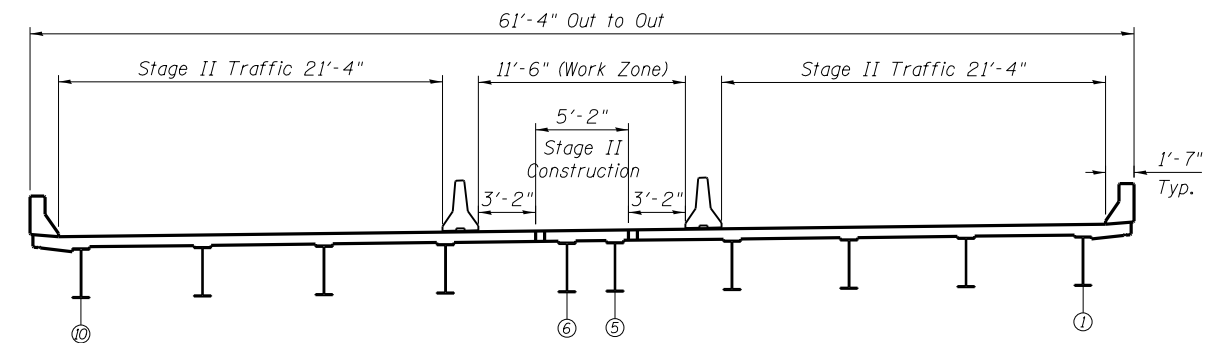

SN 082-0152 EASTBOUND CROSS SECTION
(Looking East)
STAGE II CONSTRUCTION

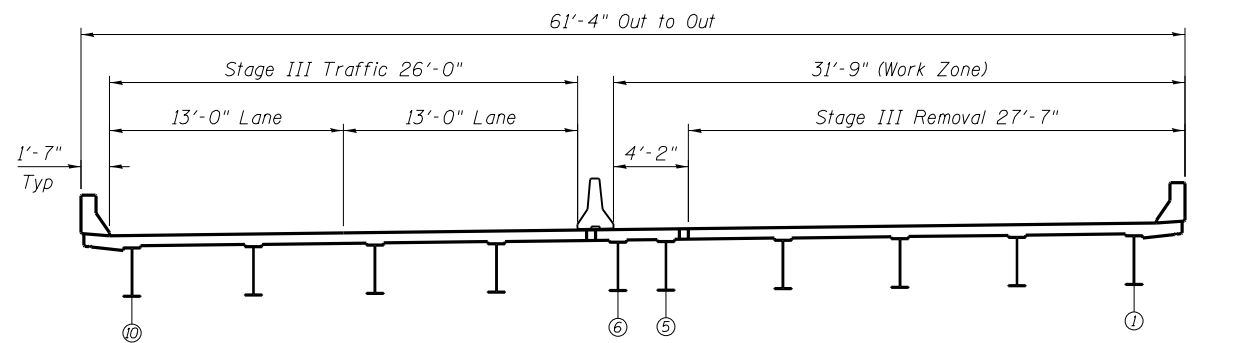

SN 082-0152 EASTBOUND CROSS SECTION
(Looking East)
STAGE III REMOVAL

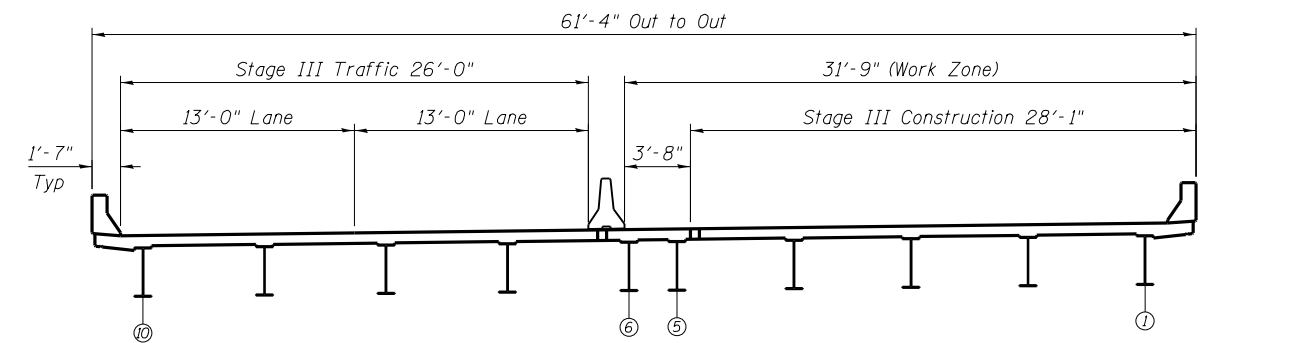

SN 082-0152 EASTBOUND CROSS SECTION
(Looking East)
STAGE III CONSTRUCTION

BENTON & ASSOCIATES, INC.

FILE NAME = P:\10e2166-2\Design\	USER NAME =	DESIGNED - MBH	REVISED -
Plans\ 082-0152 & 082-0153		CHECKED - SJH	REVISED -
0820152-76022-001-GPE.dgn	PLOT SCALE =	DRAWN - MBH	REVISED -
	PLOT DATE =	CHECKED - SJH	REVISED -

STATE OF ILLINOIS
DEPARTMENT OF TRANSPORTATION

STAGING SECTIONS
STRUCTURE NO. 082-0152

SHEET NO. 2 OF 9 SHEETS

F.A.I. RTE.	SECTION	COUNTY	TOTAL SHEETS	SHEET NO.
64	82-1HBI-2	ST. CLAIR	208	130
CONTRACT NO. 76022				
FED. ROAD DIST. NO. 8 ILLINOIS FED. AID PROJECT				

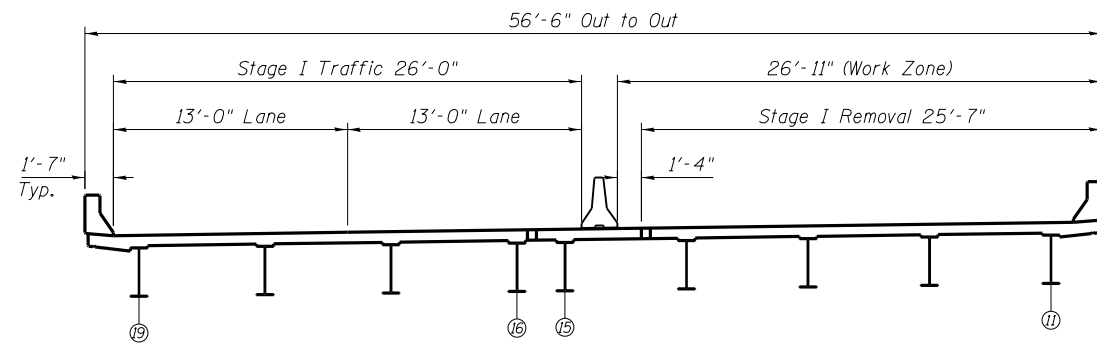

SN 082-0153 WESTBOUND CROSS SECTION
(Looking East)
STAGE I REMOVAL

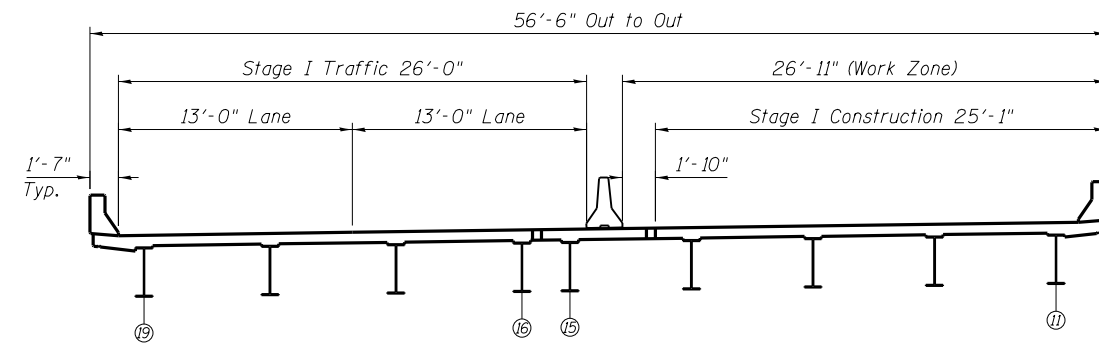

SN 082-0153 WESTBOUND CROSS SECTION
(Looking East)
STAGE I CONSTRUCTION

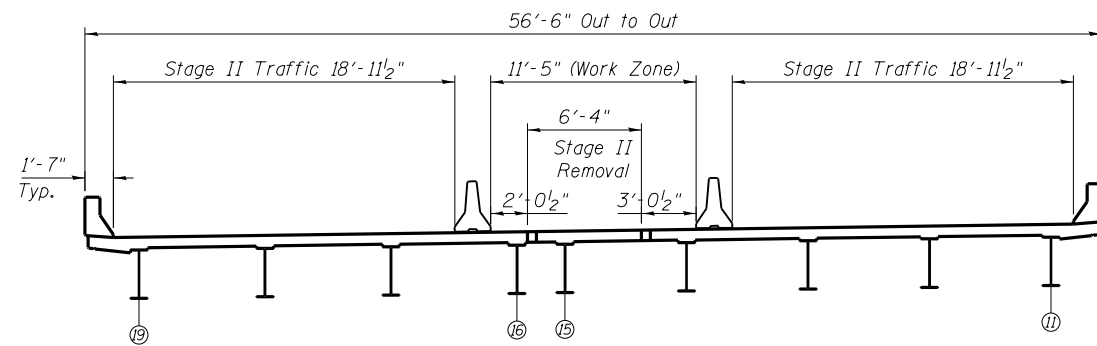

SN 082-0153 WESTBOUND CROSS SECTION
(Looking East)
STAGE II REMOVAL

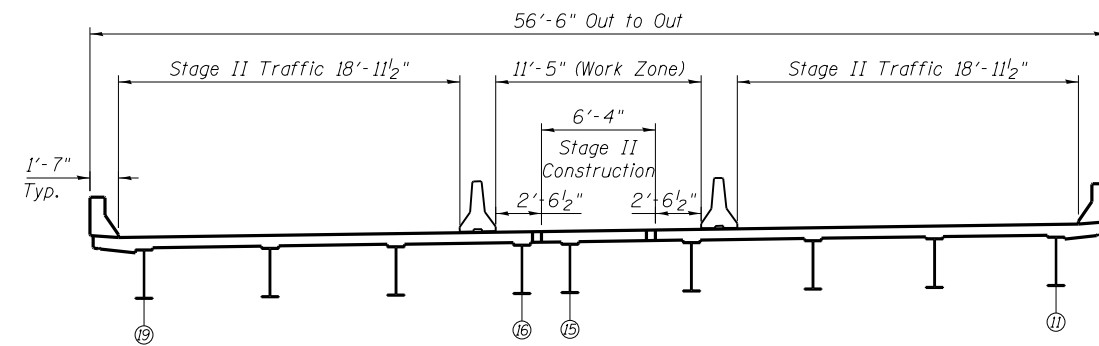

SN 082-0153 WESTBOUND CROSS SECTION
(Looking East)
STAGE II CONSTRUCTION

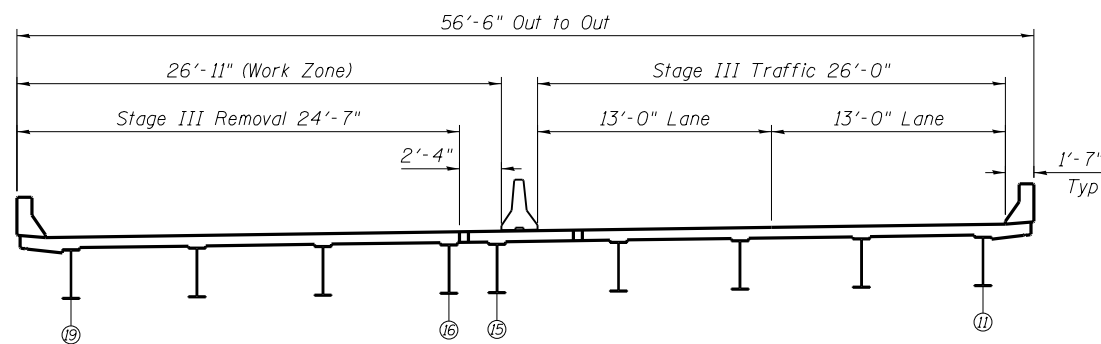

SN 082-0153 WESTBOUND CROSS SECTION
(Looking East)
STAGE III REMOVAL

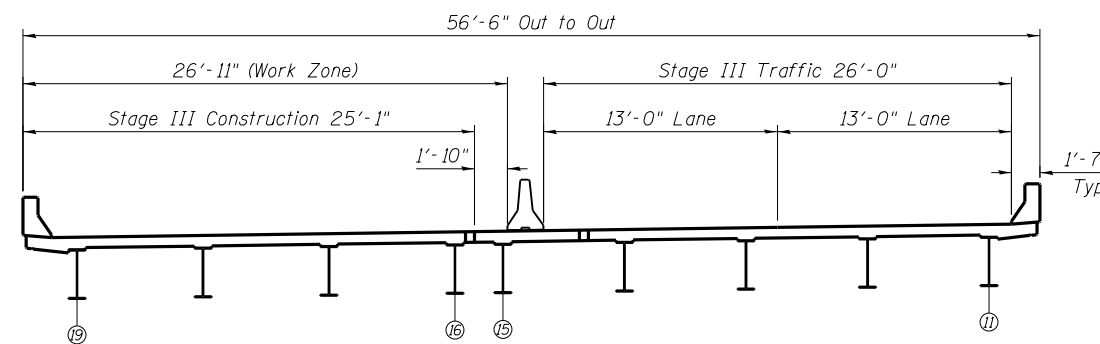

SN 082-0153 WESTBOUND CROSS SECTION
(Looking East)
STAGE III CONSTRUCTION

BENTON & ASSOCIATES, INC.

FILE NAME = P:\10e2166-2\Design\	USER NAME =	DESIGNED - MBH	REVISED -
Plans\082-0152 & 082-0153		CHECKED - SJH	REVISED -
0820152-76022-001-GPE.dgn	PLOT SCALE =	DRAWN - MBH	REVISED -
	PLOT DATE =	CHECKED - SJH	REVISED -

STATE OF ILLINOIS
DEPARTMENT OF TRANSPORTATION

STAGING SECTIONS
STRUCTURE NO. 082-0153

SHEET NO. 3 OF 9 SHEETS

F.A.I. RTE.	SECTION	COUNTY	TOTAL SHEETS	SHEET NO.
64	82-1HBI-2	ST. CLAIR	208	131
CONTRACT NO. 76022				
FED. ROAD DIST. NO. 8 ILLINOIS FED. AID PROJECT				

When "A" is 3'-6" or less, the temporary concrete barrier shall be anchored to the new slab according to Detail I or Detail II. No anchorage is required when "A" is greater than 3'-6".

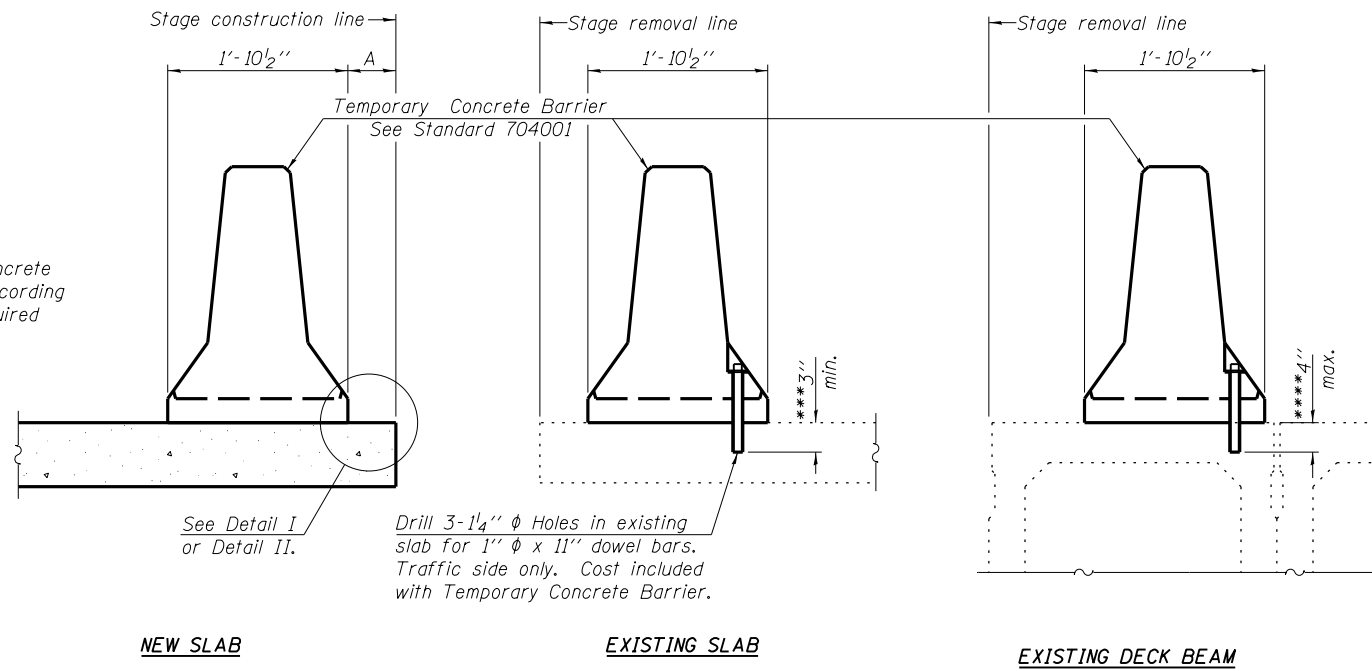

NOTES

Detail I - With Bar Splicer or Couplers:
Connect one (1) 1" x 7" x "W" steel PL to the top layer of couplers with 2-5/8" phi bolts screwed to coupler at approximate C of each barrier panel.

Detail II - With Extended Reinforcement Bars:
Connect one (1) 1" x 7" x "W" steel PL to the concrete slab or concrete wearing surface with 2-5/8" phi Expansion Anchors or cast in place inserts spaced between the top layer of reinforcement at approximate C of each barrier panel.

Cost of anchorage is included with Temporary Concrete Barrier. The 1" x 7" x "W" plate shall not be removed until stage II construction forms and all reinforcement bars are in place and the concrete is ready to be placed.

SECTIONS THRU SLAB OR DECK BEAM

*** Dimension shown is minimum required embedment into concrete. If hot-mix asphalt wearing surface is present, minimum embedment shall be in addition to wearing surface depth.

**** If existing deck beam is to remain in place after stage construction, embedment shall only be into wearing surface and not into existing deck beam concrete.

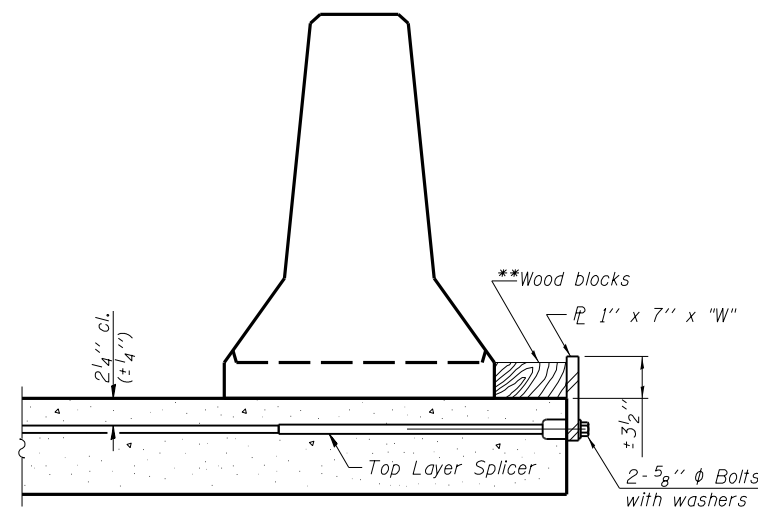

DETAIL I

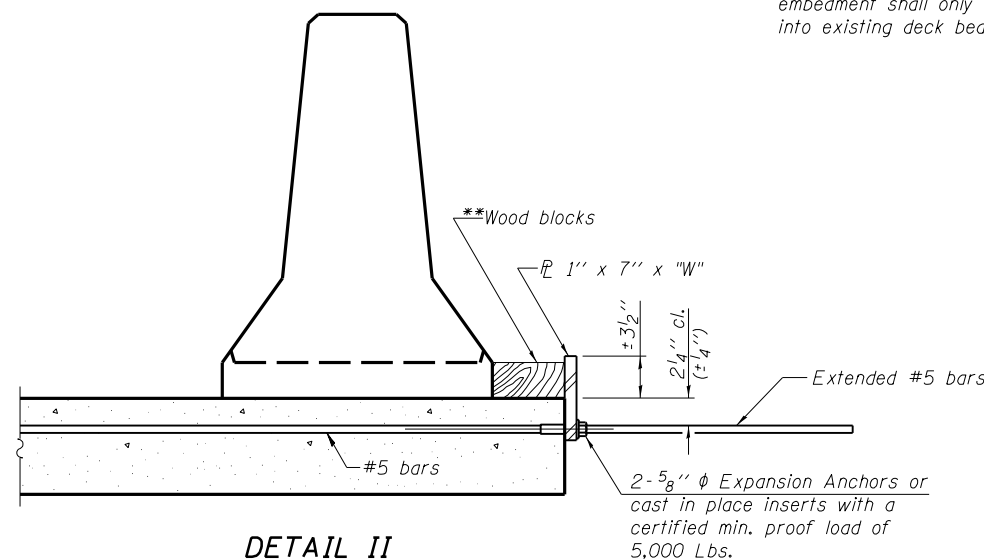

DETAIL II

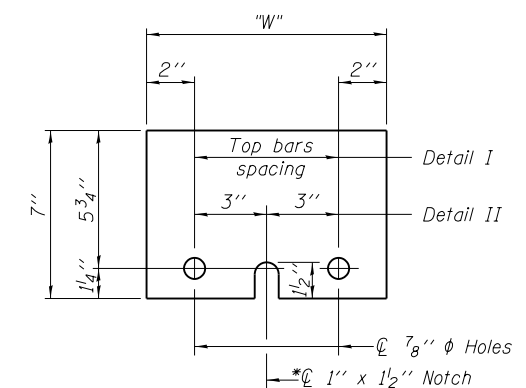

STEEL RETAINER PL 1" x 7" x "W"

* Required only with Detail II

** Wood blocks may be omitted when required to provide minimum stage traffic lane width. When the wood blocks are omitted, the concrete barrier shall be in direct contact with the steel retainer plate.

"W" = Top bars spacing + 4"

R-27 7-1-10
BENTON & ASSOCIATES, INC.

FILE NAME = P:\10e2166-2\Design\	USER NAME =	DESIGNED - MBH	REVISED -
Plans\082-0152 & 082-0153		CHECKED - SJH	REVISED -
0820152-76022-003-Barrier.dgn	PLOT SCALE =	DRAWN - MBH	REVISED -
	PLOT DATE =	CHECKED - SJH	REVISED -

STATE OF ILLINOIS
DEPARTMENT OF TRANSPORTATION

TEMPORARY CONCRETE BARRIER FOR STAGE CONSTRUCTION
STRUCTURE NO. 082-0152 & 082-0153

SHEET NO. 4 OF 9 SHEETS

F.A.I. RTE.	SECTION	COUNTY	TOTAL SHEETS	SHEET NO.
64	82-1HB1-2	ST. CLAIR	208	132
CONTRACT NO. 76022				
FED. ROAD DIST. NO. 8 ILLINOIS FED. AID PROJECT				

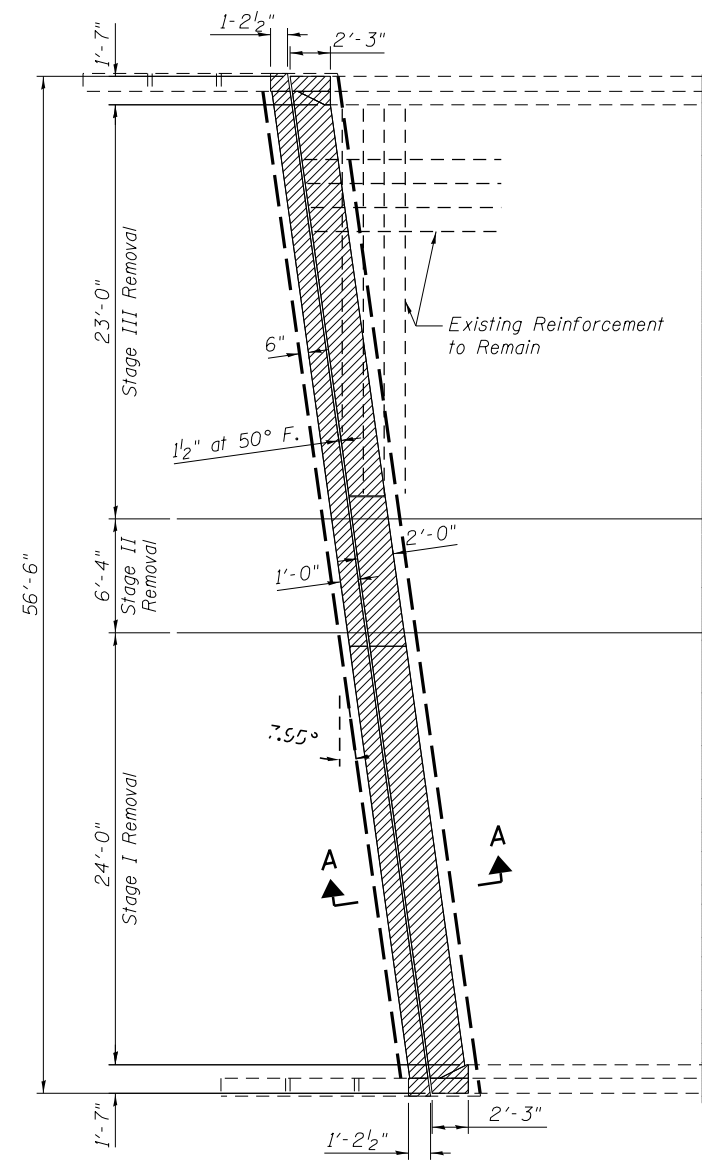

CONCRETE REMOVAL
(West Abut. shown)
(East Abut. similar)

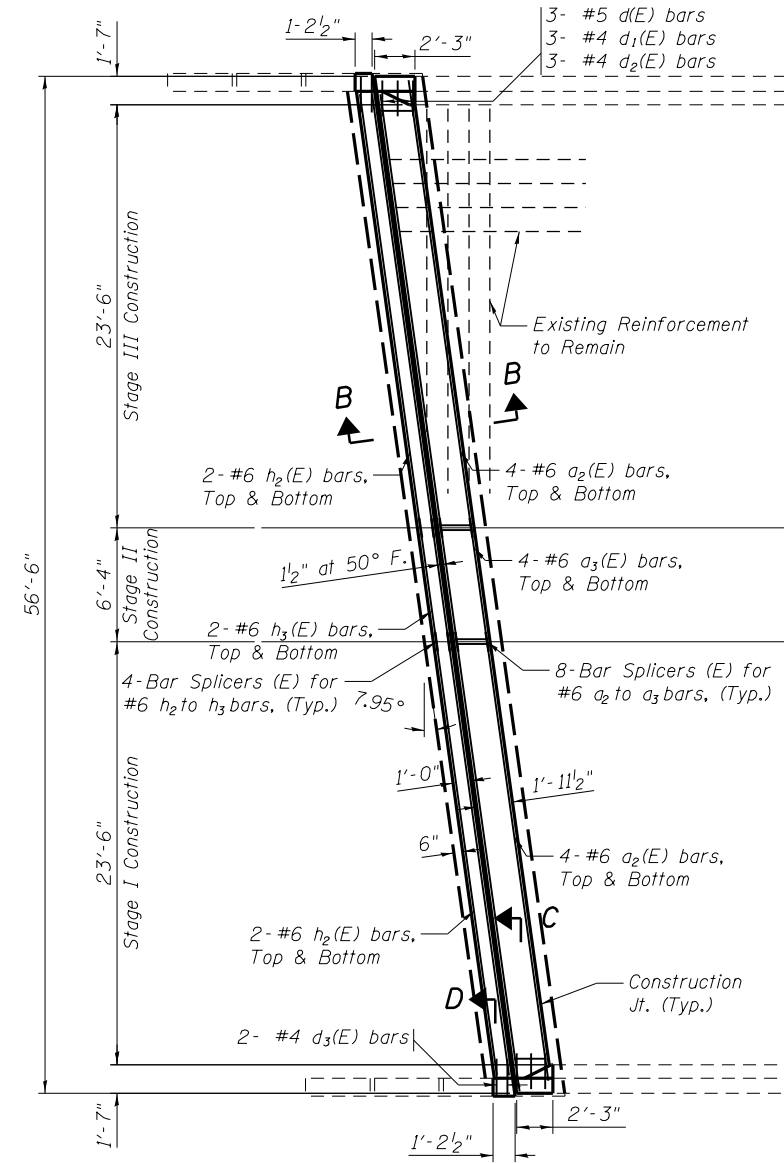

CONCRETE REPLACEMENT
(West Abut. shown)
(East Abut. similar)

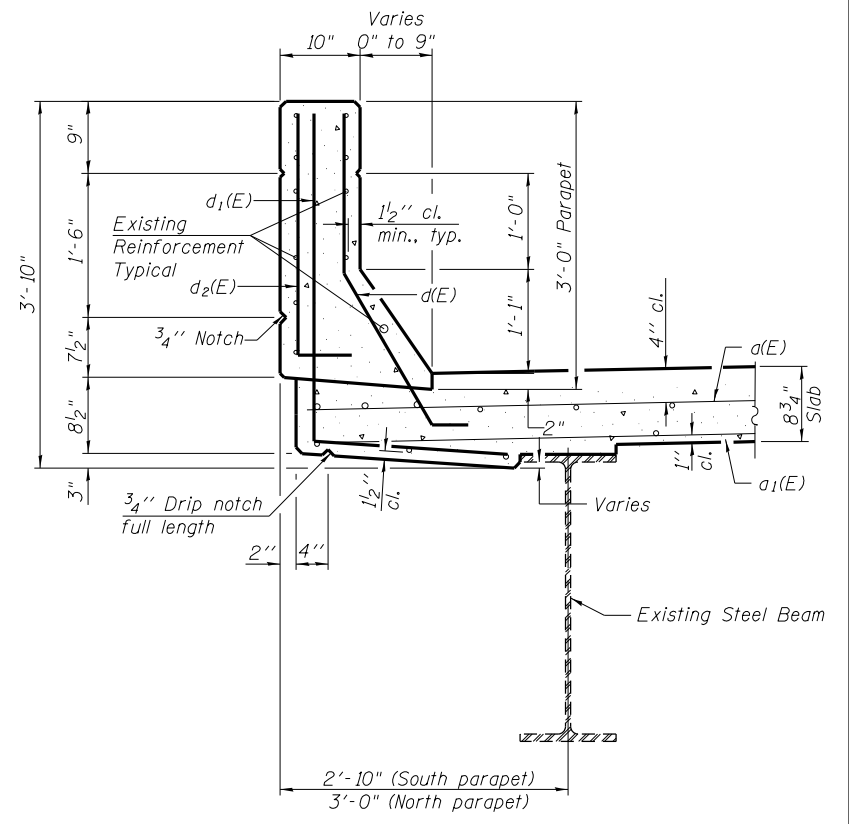

SECTION C-C

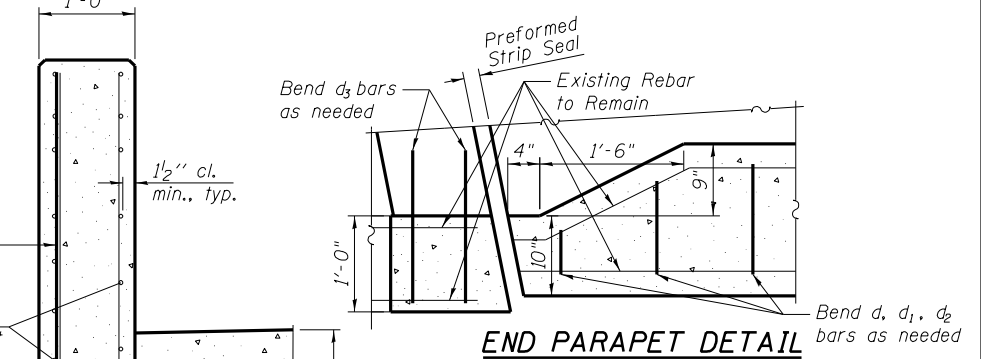

END PARAPET DETAIL

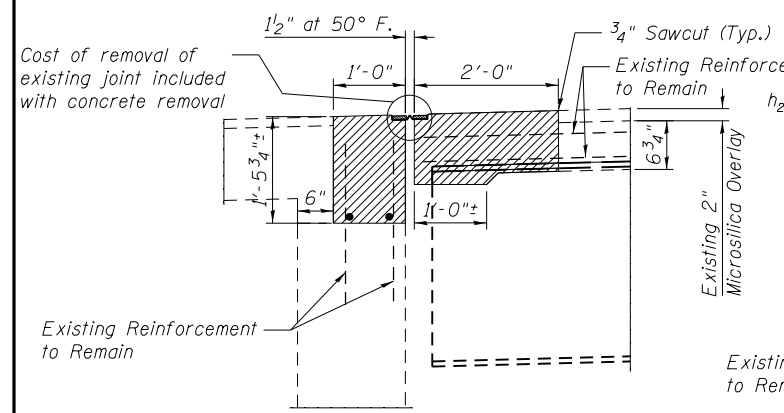

SECTION A-A

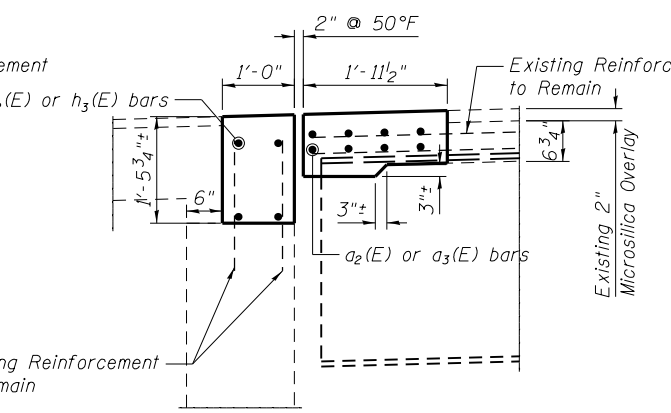

SECTION B-B

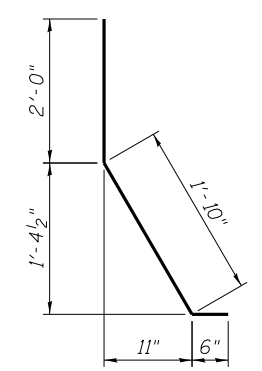

BAR d(E)

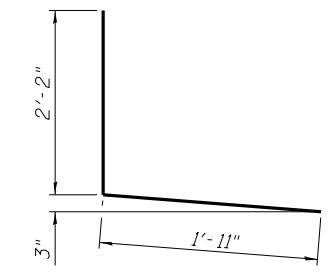

BAR d1(E)

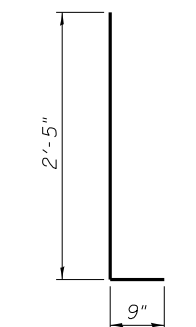

BAR d2(E)

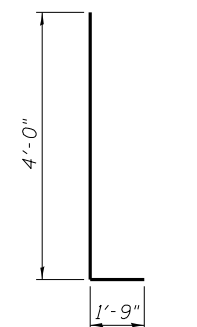

BAR d2(E)

SECTION D-D

**SUPERSTRUCTURE
BILL OF MATERIAL**

Bar	No.	Size	Length	Shape
a2(E)	32	#6	25'-0"	—
a3(E)	16	#6	6'-4"	—
d(E)	12	#5	4'-4"	L
d1(E)	12	#4	4'-1"	L
d2(E)	12	#4	3'-2"	L
d3(E)	8	#4	5'-9"	L
h2(E)	16	#6	24'-3"	—
h3(E)	8	#6	6'-4"	—
Bar Splicers			Each	48
Reinforcement Bars, Epoxy Coated			Pound	2160
Concrete Superstructure			Cu. Yds.	14.3
Concrete Removal			Cu. Yds.	14.5
Preformed Strip Seal			Foot	114

BENTON & ASSOCIATES, INC.

FILE NAME = P:\10e2166-2\ Design\	USER NAME =	DESIGNED - MBH	REVISED - 10/3/13
Plans\ 082-0152 & 082-0153		CHECKED - SJH	REVISED -
0820152-76022-006-Joint.dgn	PLOT SCALE =	DRAWN - MBH	REVISED -
	PLOT DATE	CHECKED - SJH	REVISED -

**STATE OF ILLINOIS
DEPARTMENT OF TRANSPORTATION**

**CONCRETE REMOVAL & REPLACEMENT
STRUCTURE NO. 082-0153**

SHEET NO. 7 OF 9 SHEETS

F.A.I. RT.	SECTION	COUNTY	TOTAL SHEETS	SHEET NO.
64	82-1HB1-2	ST. CLAIR	208	135
CONTRACT NO. 76022				
FED. ROAD DIST. NO. 8 ILLINOIS FED. AID PROJECT				

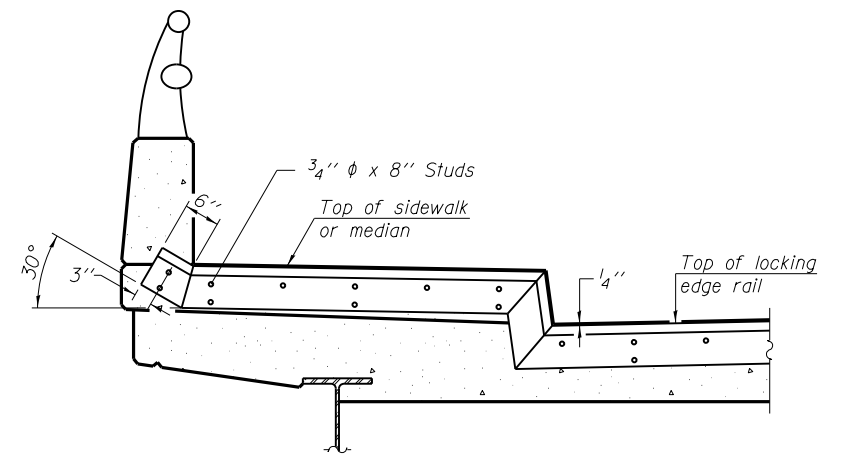
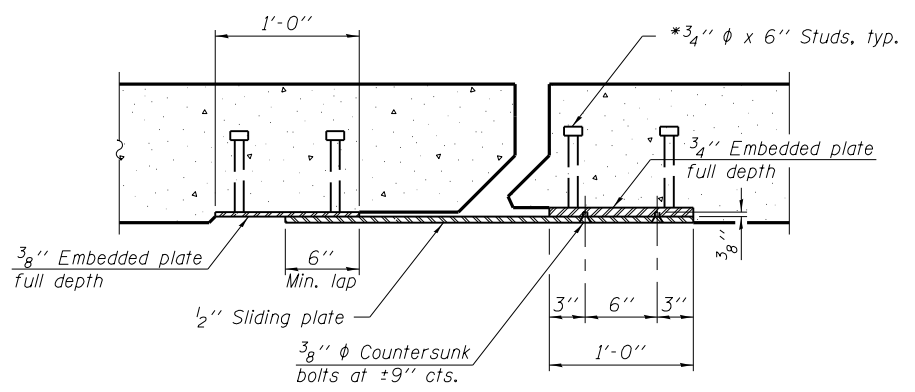
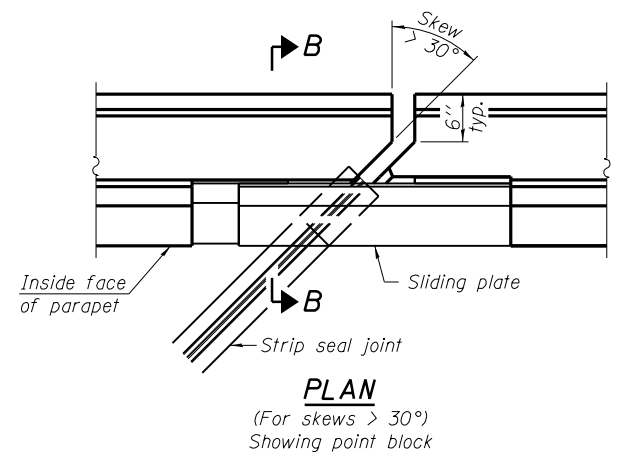
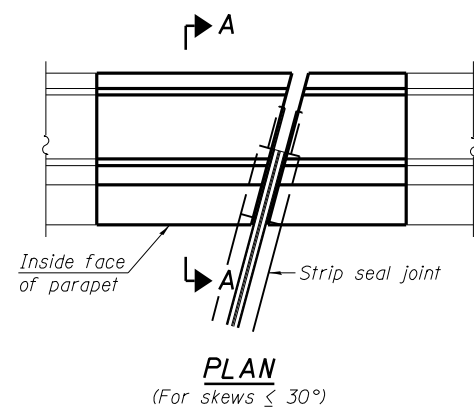

TYPICAL END TREATMENT AT SIDEWALK OR MEDIAN
 Shorter plates with a single row of studs at 12" cts. may be necessary on medians which are shallower than 9". See manufacturer's recommendation.

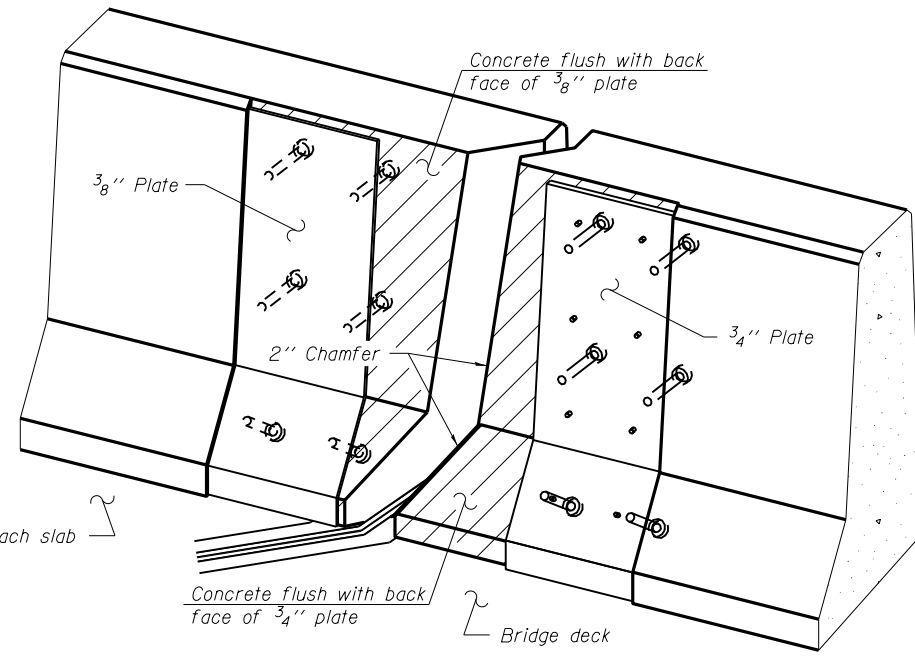
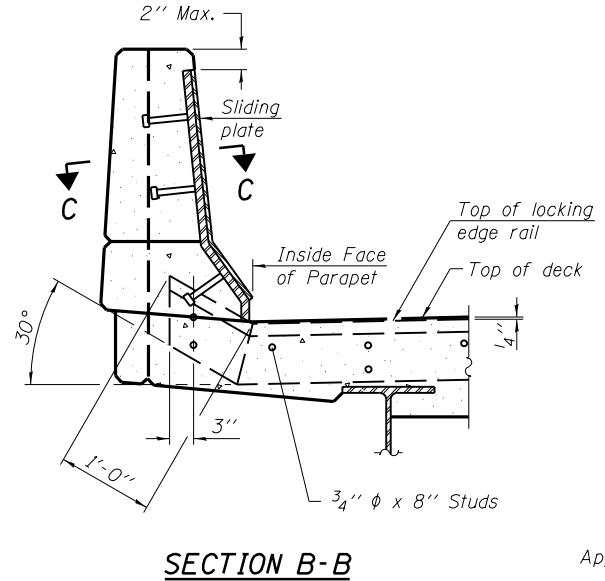
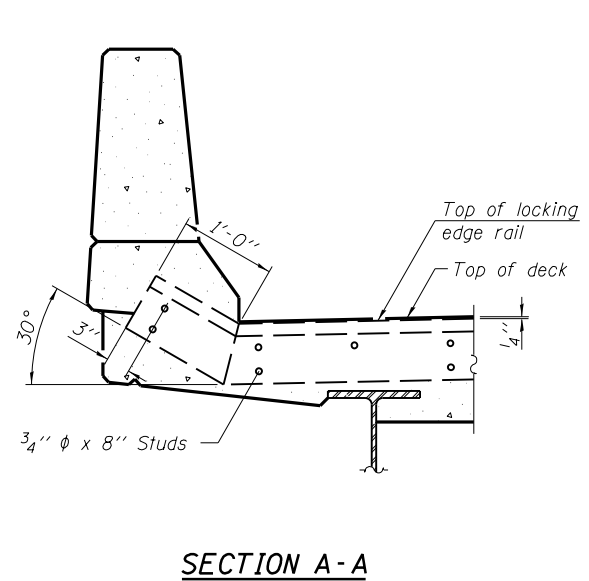

Notes:
 The strip seal shall be made continuous and shall have a minimum thickness of 1/4". The configuration of the strip seal shall match the configuration of the Locking Edge Rails. Open or "webbed" strip seal gland configurations are not permitted. The gland shall be sized for a maximum rated movement of 4 inches.
 The Locking Edge Rails depicted are conceptual only, except for the minimum dimensions shown. The actual configuration of the Locking Edge Rails and matching strip seal may vary from manufacturer to manufacturer. Flanged edge rails will not be allowed. Locking Edge Rails may be spliced at slope discontinuities.
 The manufacturer's recommended installation methods shall be followed.
 The joint opening and deck dimensions detailed on the superstructure are based on a rolled rail expansion joint. If the Contractor elects to use the welded rail expansion joint, the opening and deck dimensions shall be modified according to the dimensions detailed on this sheet. Required modifications shall be made at no additional cost to the State.
 All steel components shall be galvanized after fabrication according to Article 520.03 of the Standard Specifications.
 Maximum space between rail segments at stage lines shall be 3/16", sealed with a suitable sealant.
 Parapet plates and anchorage studs for skews > 30 degrees included in the cost of Preformed Joint Strip Seal.

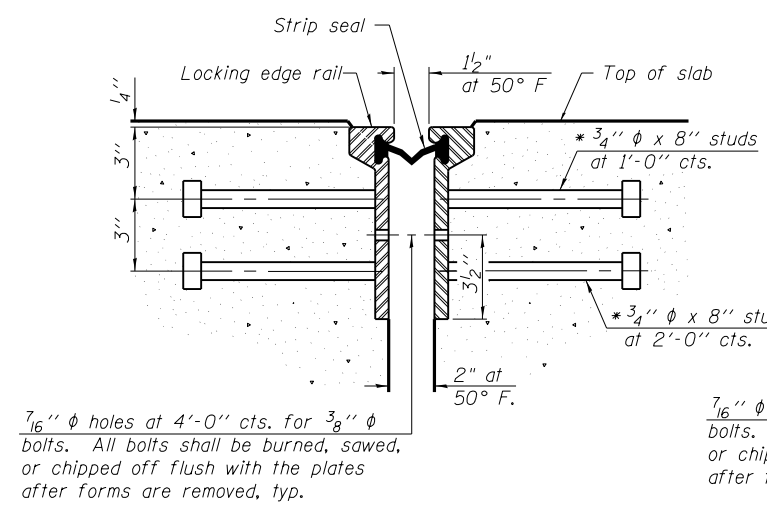

SECTION THRU ROLLED RAIL JOINT

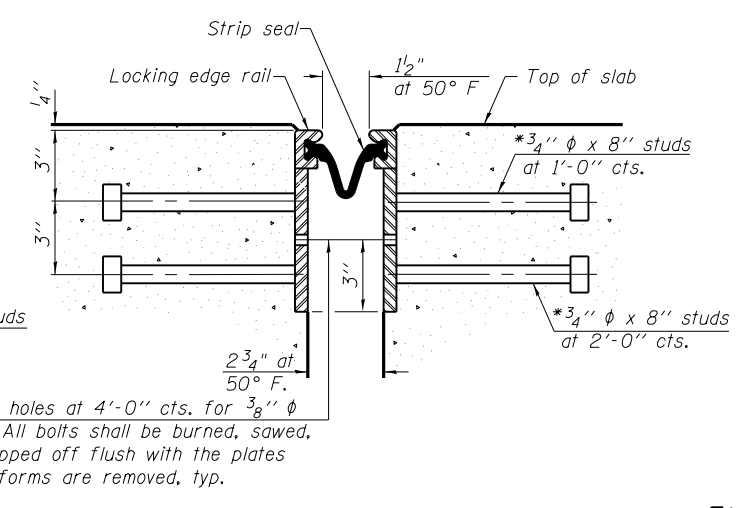

SECTION THRU WELDED RAIL JOINT

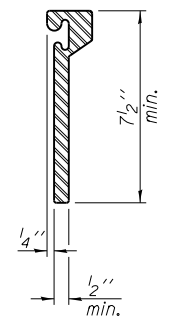

ROLLED EXTRUDED RAIL

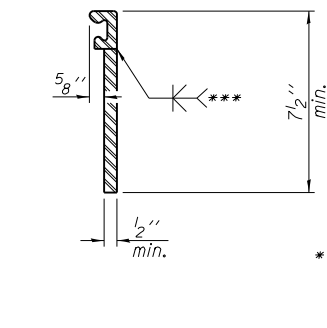

WELDED RAIL

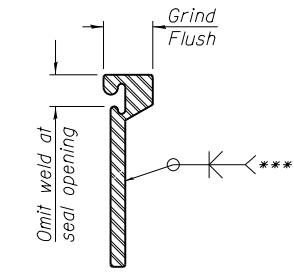

LOCKING EDGE RAIL SPLICE

*** Back gauge not required if complete joint penetration is verified by mock-up.
 The inside of the locking edge rail groove shall be free of weld residue.
 Rolled rail shown, welded rail similar.

LOCKING EDGE RAILS

BILL OF MATERIAL

Item	Unit	Total
Preformed Joint Strip Seal	Foot	238

EJ-SSJ 7-1-10
BENTON & ASSOCIATES, INC.

* Granular or solid flux filled headed studs conforming to Article 1006.32 of the Std. Specs., automatically end welded.

FILE NAME = P:\10e2166-2\ Design\ Plans\ 082-0152 & 082-0153	USER NAME =	DESIGNED - MBH	REVISED -
0820152-76022-007-Joint.dgn	PLOT SCALE =	CHECKED - SJH	REVISED -
	PLOT DATE =	DRAWN - MBH	REVISED -
		CHECKED - SJH	REVISED -

STATE OF ILLINOIS
DEPARTMENT OF TRANSPORTATION

PREFORMED JOINT STRIP SEAL
STRUCTURE NO. 082-0152 & 082-0153

SHEET NO. 8 OF 9 SHEETS

F.A.I. RTE.	SECTION	COUNTY	TOTAL SHEETS	SHEET NO.
64	82-1HB1-2	ST. CLAIR	208	136
CONTRACT NO. 76022				
FED. ROAD DIST. NO. 8 ILLINOIS FED. AID PROJECT				

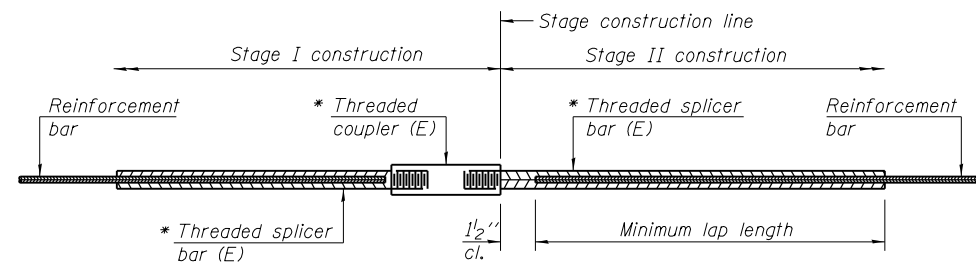

STANDARD BAR SPLICER ASSEMBLY

Minimum Lap Lengths					
Bar size to be spliced	Table 1	Table 2	Table 3	Table 4	Table 5
3, 4	1'-5"	1'-11"	2'-1"	2'-4"	2'-3"
5	1'-9"	2'-5"	2'-7"	2'-11"	2'-10"
6	2'-1"	2'-11"	3'-1"	3'-6"	3'-4"
7	2'-9"	3'-10"	4'-2"	4'-8"	4'-6"
8	3'-8"	5'-1"	5'-5"	6'-2"	5'-10"
9	4'-7"	6'-5"	6'-10"	7'-9"	7'-5"

- Table 1: Black bar, 0.8 Class C
- Table 2: Black bar, Top bar lap, 0.8 Class C
- Table 3: Epoxy bar, 0.8 Class C
- Table 4: Epoxy bar, Top bar lap, 0.8 Class C
- Table 5: Epoxy bar, Top bar lap, Class B

Threaded splicer bar length = min. lap length + 1/2" + thread length

* Epoxy not required on Bar Splicer Assembly components used in conjunction with black bars.

Location	Bar size	No. assemblies required	Table for minimum lap length
SN 082-0152 Deck	#6	32	Table 3
SN 082-0152 Hatch	#6	16	Table 3
SN 082-0153 Deck	#6	32	Table 3
SN 082-0153 Hatch	#6	16	Table 3

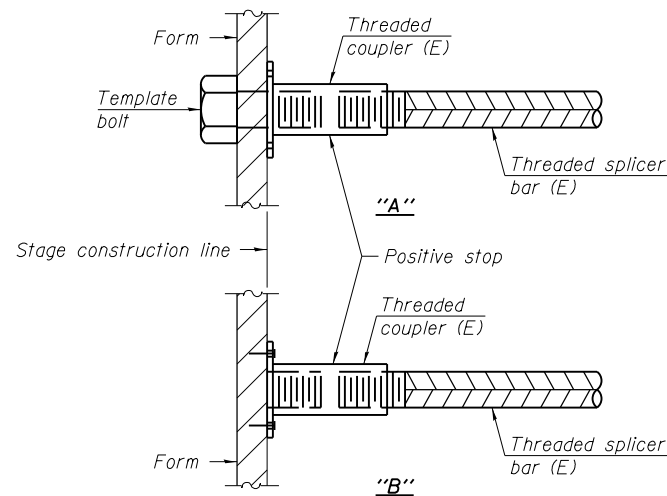

INSTALLATION AND SETTING METHODS

"A" : Set bar splicer assembly by means of a template bolt.
 "B" : Set bar splicer assembly by nailing to wood forms or cementing to steel forms.
 (E) : Indicates epoxy coating.

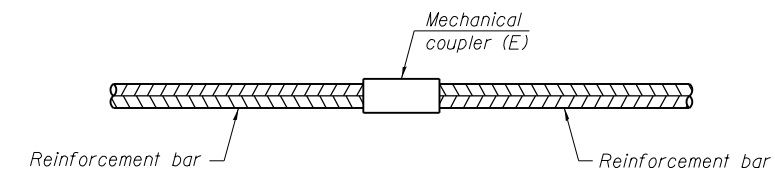

STANDARD MECHANICAL SPLICER

Location	Bar size	No. assemblies required

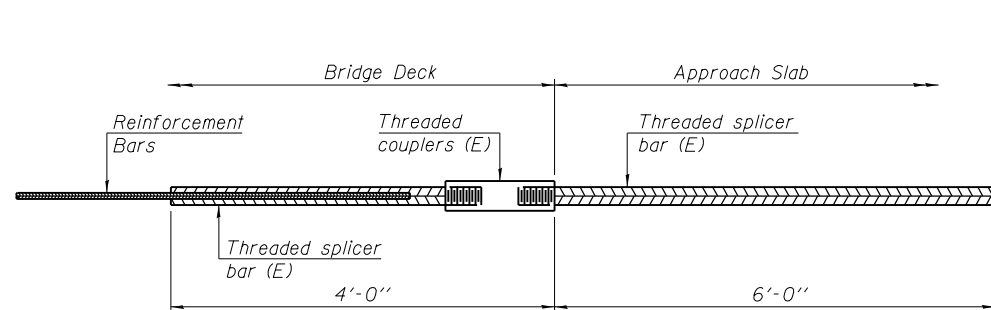

BAR SPLICER ASSEMBLY FOR #5 BAR ON INTEGRAL OR SEMI-INTEGRAL ABUTMENTS

No. required =

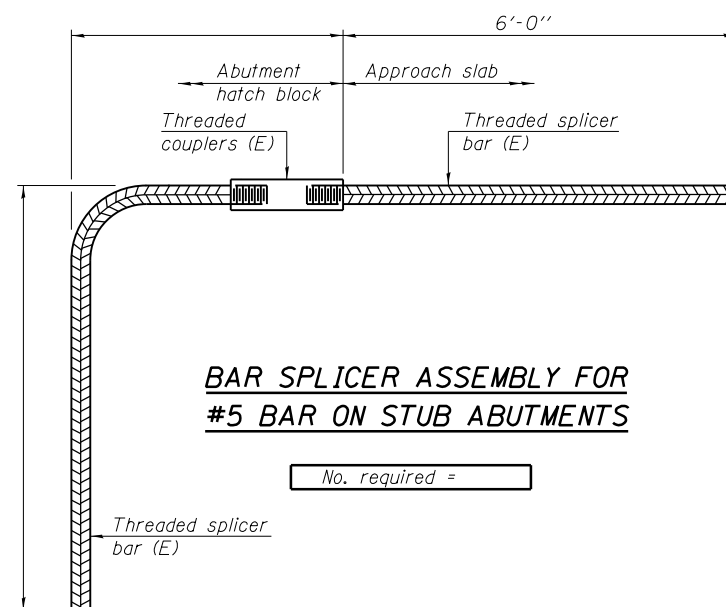

BAR SPLICER ASSEMBLY FOR #5 BAR ON STUB ABUTMENTS

No. required =

NOTES

- Splicer bars shall be deformed with threaded ends and have a minimum 60 ksi yield strength.
- All reinforcement shall be lapped and tied to the splicer bars.
- Bar splicer assemblies shall be epoxy coated according to the requirements for reinforcement bars. See Section 508 of the Standard Specifications.
- See special provision for Mechanical Splicers.
- See approved list of bar splicer assemblies and mechanical splicers for alternatives.

BSD-1 7-1-10
 BENTON & ASSOCIATES, INC.

FILE NAME = P:\10e2166-2\Design\Plans\082-0152 & 082-0153\0820152-76022-009-Splicer.dgn	USER NAME =	DESIGNED - MBH	REVISED - 10/3/13
		CHECKED - SJH	REVISED -
	PLOT SCALE =	DRAWN - MBH	REVISED -
	PLOT DATE =	CHECKED - SJH	REVISED -

STATE OF ILLINOIS
 DEPARTMENT OF TRANSPORTATION

BAR SPLICER ASSEMBLY AND MECHANICAL SPLICER DETAILS
 STRUCTURE NO. 082-0152 & 082-0153

SHEET NO. 9 OF 9 SHEETS

F.A.I. RTE.	SECTION	COUNTY	TOTAL SHEETS	SHEET NO.
64	82-1HB1-2	ST. CLAIR	208	137
CONTRACT NO. 76022				
FED. ROAD DIST. NO. 8 ILLINOIS FED. AID PROJECT				

INDEX OF SHEETS

General Plan & Elevation	1
Staging	2-3
Temporary Concrete Barrier For Stage Construction	4
Deck Repairs	5
Concrete Removal & Replacement	6-7
Preformed Joint Strip Seal	8
Substructure Repairs	9
Bar Splicer Assembly Details	10

GENERAL NOTES

- All new structural steel shall conform to AASHTO Classification M270 Gr. 36 unless otherwise noted.
- Fasteners shall be AASHTO M164 Type 1, mechanically galvanized bolts (in painted areas and M164 Type 3 in unpainted areas). Bolts 1/2" φ, holes 5/16" φ, unless otherwise noted.
- No field welding is permitted except as specified in the contract documents.
- Reinforcement bars designated (E) shall be epoxy coated.
- Prior to pouring the new concrete deck, all heavy or loose rust, loose mill scale, and other loose or potentially detrimental foreign material shall be removed from the surfaces in contact with concrete. Tightly adhered paint may remain unless otherwise noted. Removal shall be accomplished by methods that will not damage the steel and the cost will be included in the pay item covering removal of the existing concrete.
- As directed by the Engineer, existing construction accessories welded to the top flange of beams and girders shall be removed. The weld areas shall be ground flush and inspected for cracks using magnetic particle testing (MT) or dye penetrant testing (PT) by qualified personnel approved by the Engineer. Any cracks that can not be removed by grinding 1/4" in. deep shall be identified and reported to the Bureau of Bridges and Structures for further disposition. The cost of removing welded accessories, grinding and inspecting weld areas and grinding cracks will be paid for according to Article 109.04 of the Standard Specifications.
- Plan dimensions and details relative to existing plans are subject to nominal construction variations. The Contractor shall field verify existing dimensions and details affecting new construction and make necessary approved adjustments prior to construction or ordering of materials. Such variations shall not be cause for additional compensation for a change in scope of the work, however, the Contractor will be paid for the quantity actually furnished at the unit price bid for the work.
- Existing reinforcement bars extending into the removal area shall be cleaned, straightened and incorporated into the new construction. Any reinforcement bars that are damaged during concrete removal shall be replaced with an approved bar splicer or anchorage system. Cost included with Concrete Removal.
- Joint openings shall be adjusted according to Article 520.04 of the Standard Specs. when the deck is poured at an ambient temperature other than 50° F.
- Areas of deck repairs shown are estimated. The Engineer shall show actual locations of deck repairs on As-built Plans.
- The existing structural steel contains lead. The contractor shall take appropriate precautions to deal with the presence of lead on this project.
- All structural steel shall be shop painted with the inorganic zinc rich primer per AASHTO M300, Type 1. Color to match existing. Cost included with Furnishing and Erecting Structural Steel.
- Existing structural steel that will be in contact with new structural steel shall be cleaned and painted prior to erection as required by the Special Provisions "Cleaning & Painting Contact Surface Areas of Existing Steel Structures".

ORIGINAL DESIGN STRESSES

FIELD UNITS

f'c = 1,400 psi (Piers and Superstructure)
 f'c = 1,000 psi (Substructure w/ Earth Pressure)
 fy = 20,000 psi (Reinforcement)
 fy = 20,000 psi (Structural Steel A36)
 n = 10
 N = 75 psi

FAI 64 CURVE DATA

(Spiral Curve)

PI STA. = 183+40.62
 Δ = 30° 24' 20"
 Δc = 27° 24' 20"
 Dc = 1° 30' 0"
 Rc = 3,819.72'
 Lc = 1827.04'
 Ls = 200.00'
 θs = 1° 30' 0"
 Ts = 1138.11'
 Es = 138.98'
 S.E. = 0.01'/FT.

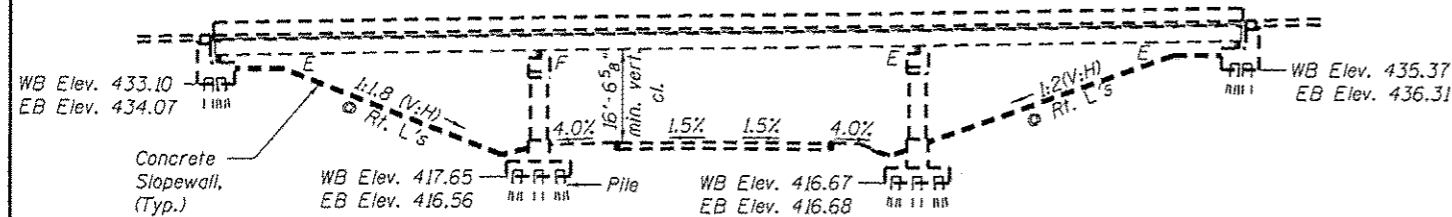

ELEVATION

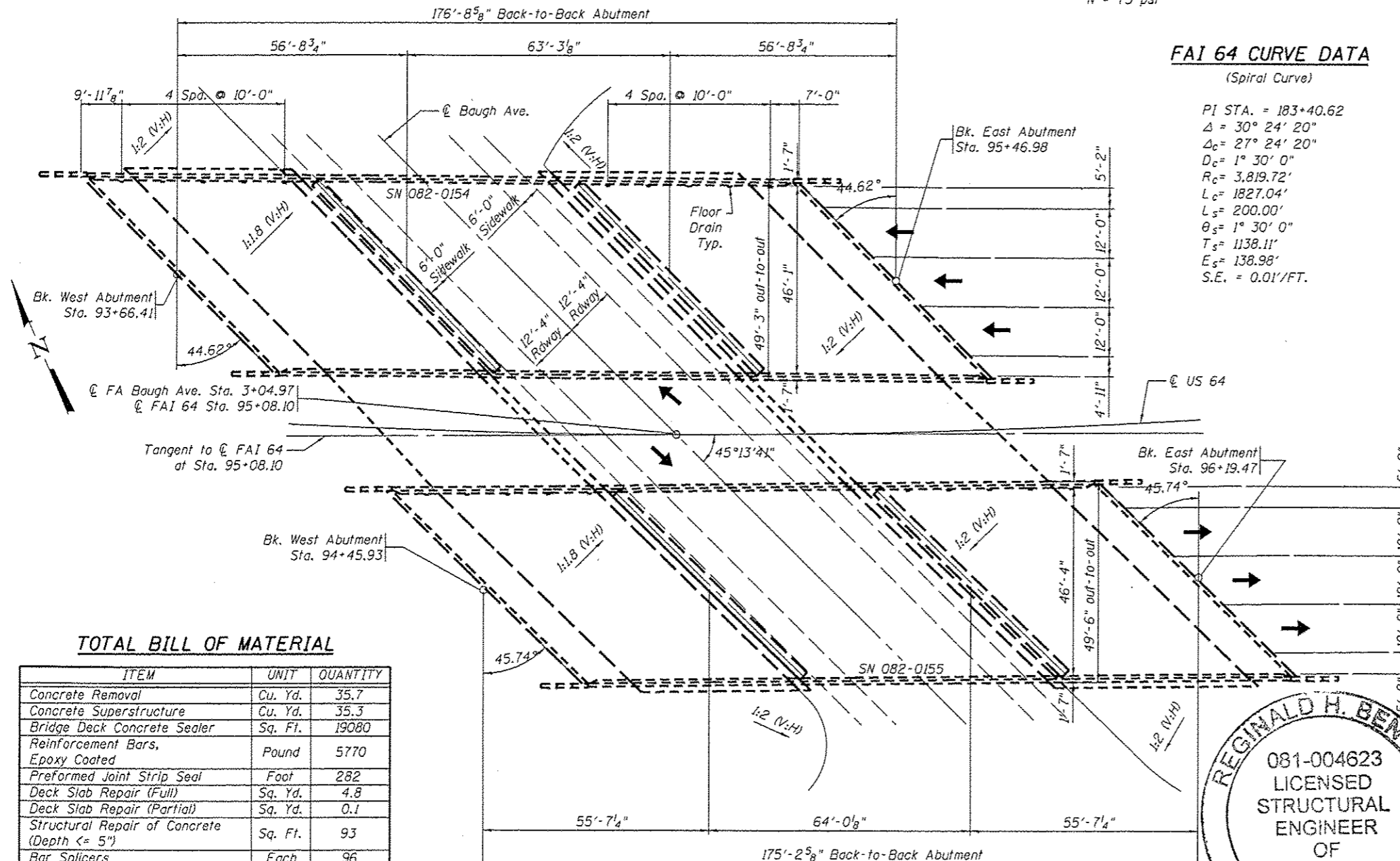

PLAN

TOTAL BILL OF MATERIAL

ITEM	UNIT	QUANTITY
Concrete Removal	Cu. Yd.	35.7
Concrete Superstructure	Cu. Yd.	35.3
Bridge Deck Concrete Sealer	Sq. Ft.	19080
Reinforcement Bars, Epoxy Coated	Pound	5770
Preformed Joint Strip Seal	Foot	282
Deck Slab Repair (Full)	Sq. Yd.	4.8
Deck Slab Repair (Partial)	Sq. Yd.	0.1
Structural Repair of Concrete (Depth <= 5")	Sq. Ft.	93
Bar Splicers	Each	96
Furnishing and Erecting Structural Steel	Pound	3160
Anchor Bolts, 1"	Each	64

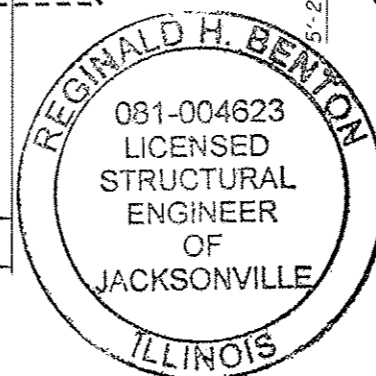

Reginald H. Benton
 10/3/13 Exp 11/30/14

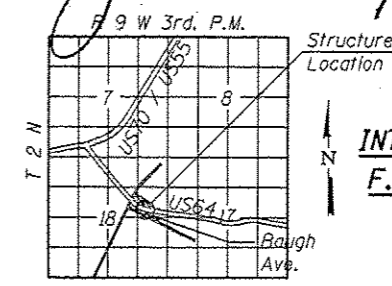

GENERAL PLAN & ELEVATION
INTERSTATE 64 OVER BAUGH AVE.
F.A.I. RTE. 64 - SEC. 82-1HB1-3
ST. CLAIR COUNTY
US 64 STA. 95+08.103
BAUGH AVE. STA.

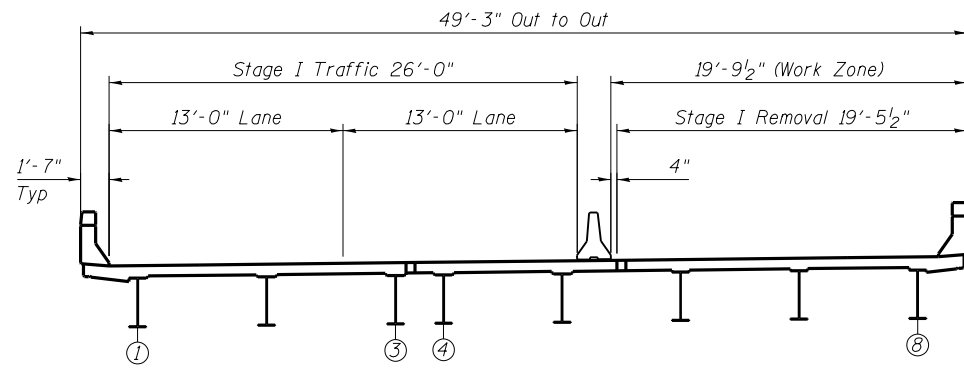

SN 082-0154 WESTBOUND CROSS SECTION
(Looking East)
STAGE I REMOVAL

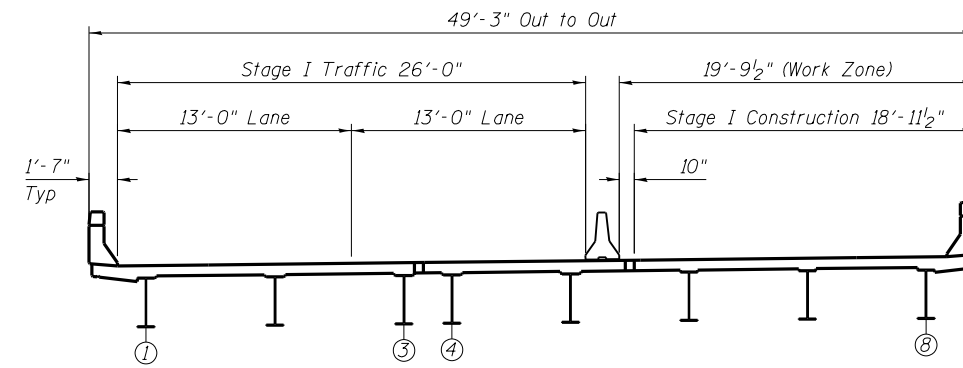

SN 082-0154 WESTBOUND CROSS SECTION
(Looking East)
STAGE I CONSTRUCTION

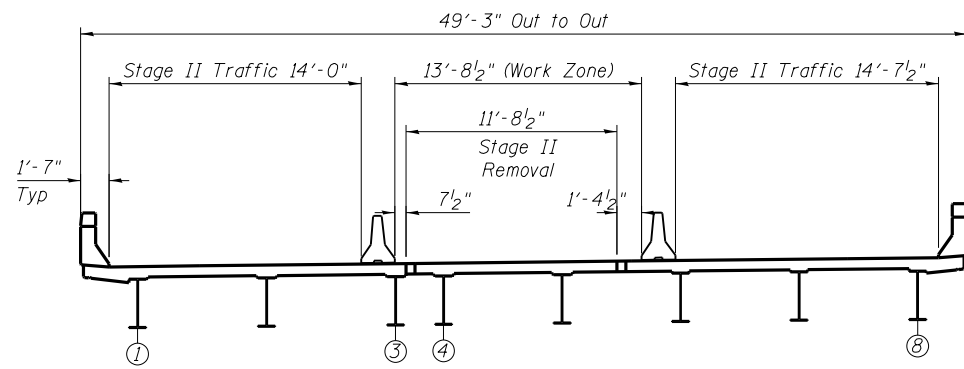

SN 082-0154 WESTBOUND CROSS SECTION
(Looking East)
STAGE II REMOVAL

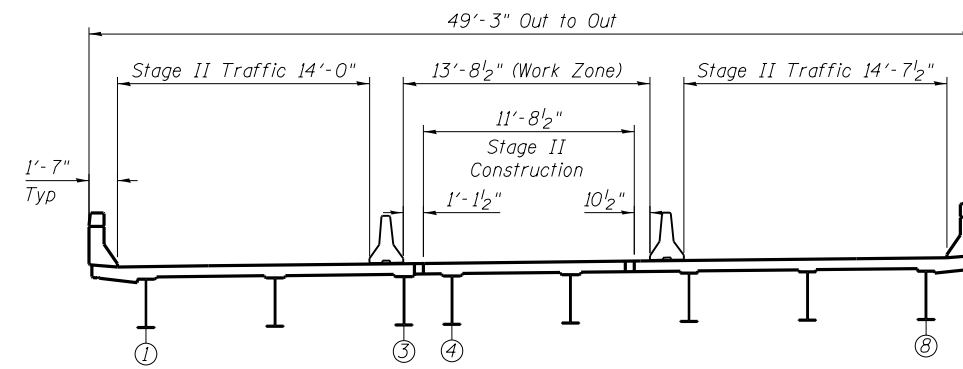

SN 082-0154 WESTBOUND CROSS SECTION
(Looking East)
STAGE II CONSTRUCTION

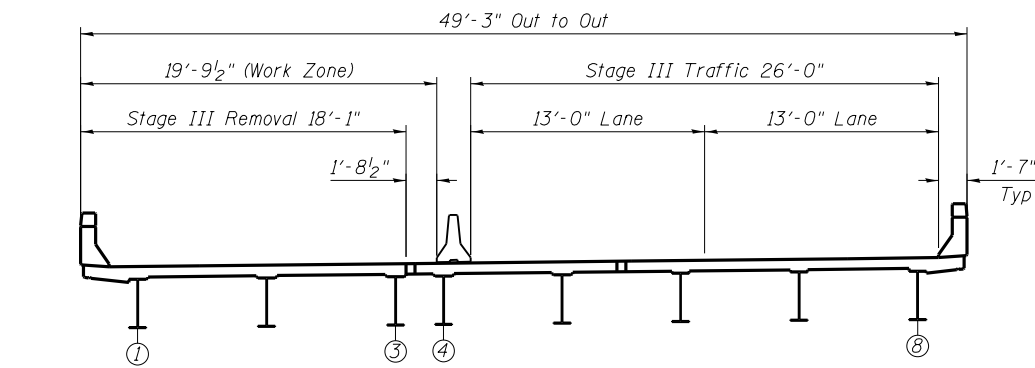

SN 082-0154 WESTBOUND CROSS SECTION
(Looking East)
STAGE III REMOVAL

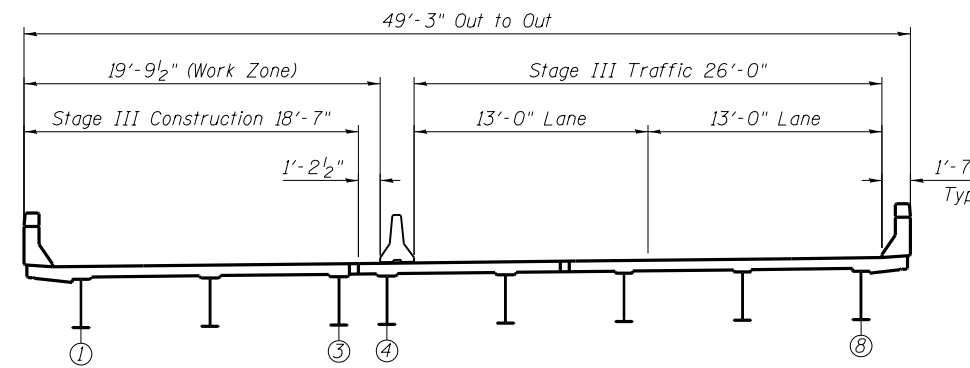

SN 082-0154 WESTBOUND CROSS SECTION
(Looking East)
STAGE III CONSTRUCTION

BENTON & ASSOCIATES, INC.

FILE NAME = P:\10e2166-2\ Design\	USER NAME =	DESIGNED - MBH	REVISED -
Plans\ 082-0154 & 082-0155		CHECKED - SJH	REVISED -
0820154-76022-002-Staging.dgn	PLOT SCALE =	DRAWN - MBH	REVISED -
	PLOT DATE =	CHECKED - SJH	REVISED -

STATE OF ILLINOIS
DEPARTMENT OF TRANSPORTATION

STAGING SECTIONS
STRUCTURE NO. 082-0154

SHEET NO. 2 OF 10 SHEETS

F.A.I. RTE.	SECTION	COUNTY	TOTAL SHEETS	SHEET NO.
64	82-1HB1-3	ST. CLAIR	208	139
CONTRACT NO. 76022				
FED. ROAD DIST. NO. 8 ILLINOIS FED. AID PROJECT				

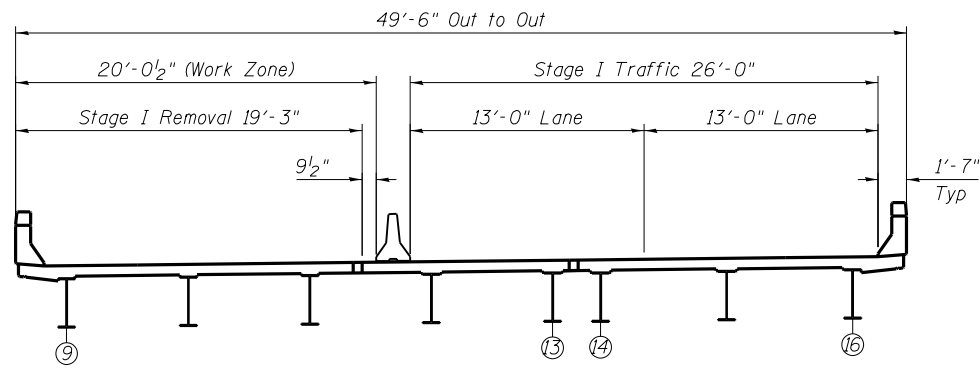

SN 082-0155 EASTBOUND CROSS SECTION
(Looking East)
STAGE I REMOVAL

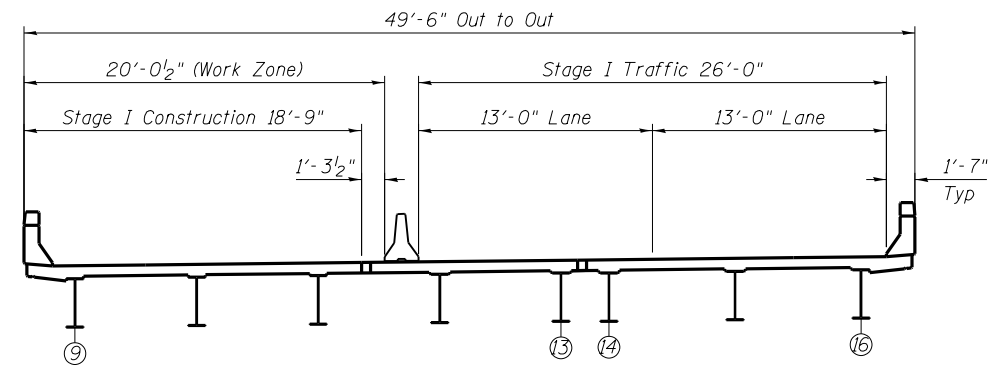

SN 082-0155 EASTBOUND CROSS SECTION
(Looking East)
STAGE I CONSTRUCTION

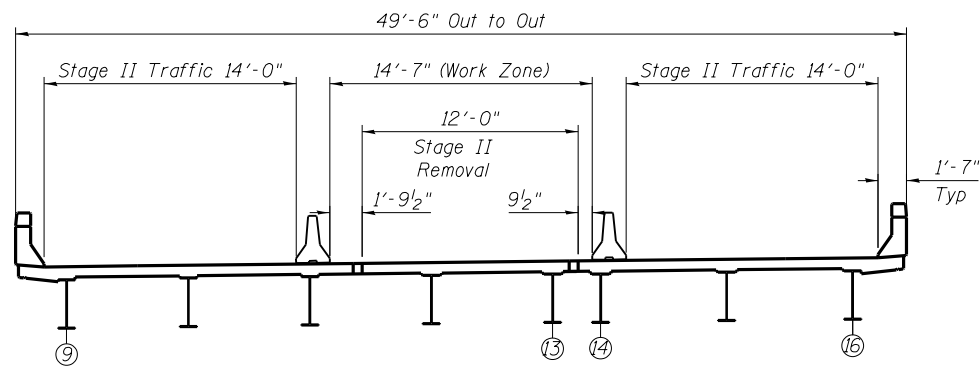

SN 082-0155 EASTBOUND CROSS SECTION
(Looking East)
STAGE II REMOVAL

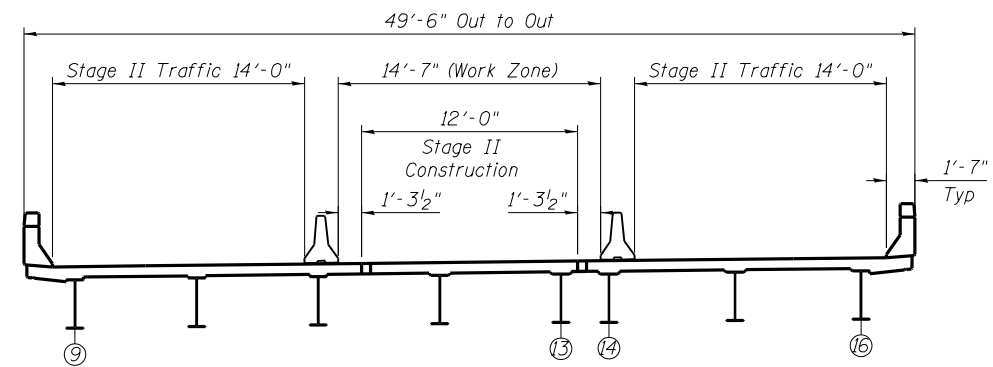

SN 082-0155 EASTBOUND CROSS SECTION
(Looking East)
STAGE II CONSTRUCTION

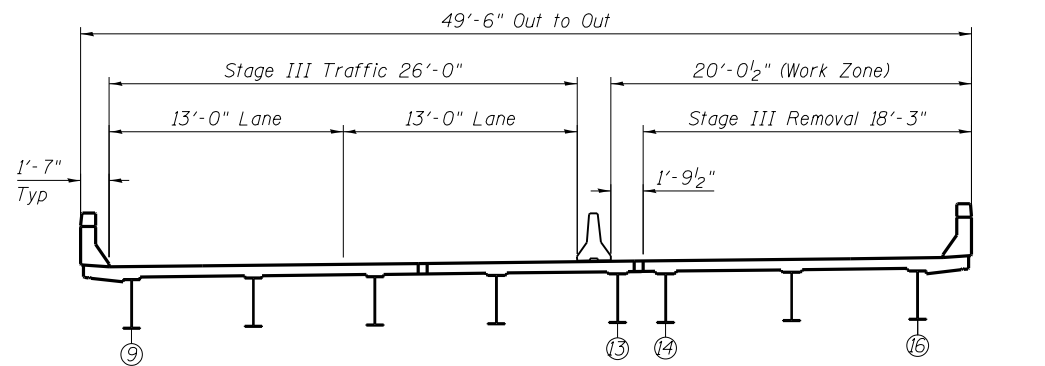

SN 082-0155 EASTBOUND CROSS SECTION
(Looking East)
STAGE III REMOVAL

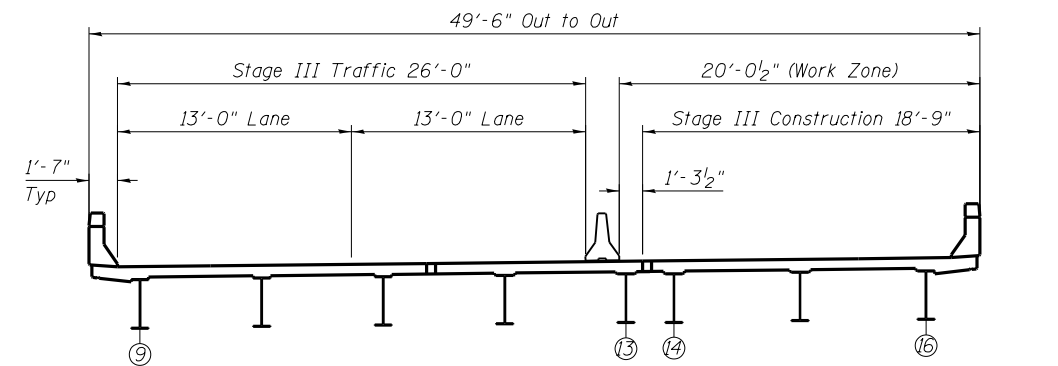

SN 082-0155 EASTBOUND CROSS SECTION
(Looking East)
STAGE III CONSTRUCTION

BENTON & ASSOCIATES, INC.

FILE NAME = P:\10e2166-2\ Design\	USER NAME =	DESIGNED - MBH	REVISED -
Plans\ 082-0154 & 082-0155		CHECKED - SJH	REVISED -
0820154-76022-002-Staging.dgn	PLOT SCALE =	DRAWN - MBH	REVISED -
	PLOT DATE =	CHECKED - SJH	REVISED -

STATE OF ILLINOIS
DEPARTMENT OF TRANSPORTATION

STAGING SECTIONS
STRUCTURE NO. 082-0155

SHEET NO. 3 OF 10 SHEETS

F.A.I. RTE.	SECTION	COUNTY	TOTAL SHEETS	SHEET NO.
64	82-1HB1-3	ST. CLAIR	208	140
CONTRACT NO. 76022				
FED. ROAD DIST. NO. 8 ILLINOIS FED. AID PROJECT				

When "A" is 3'-6" or less, the temporary concrete barrier shall be anchored to the new slab according to Detail I or Detail II. No anchorage is required when "A" is greater than 3'-6".

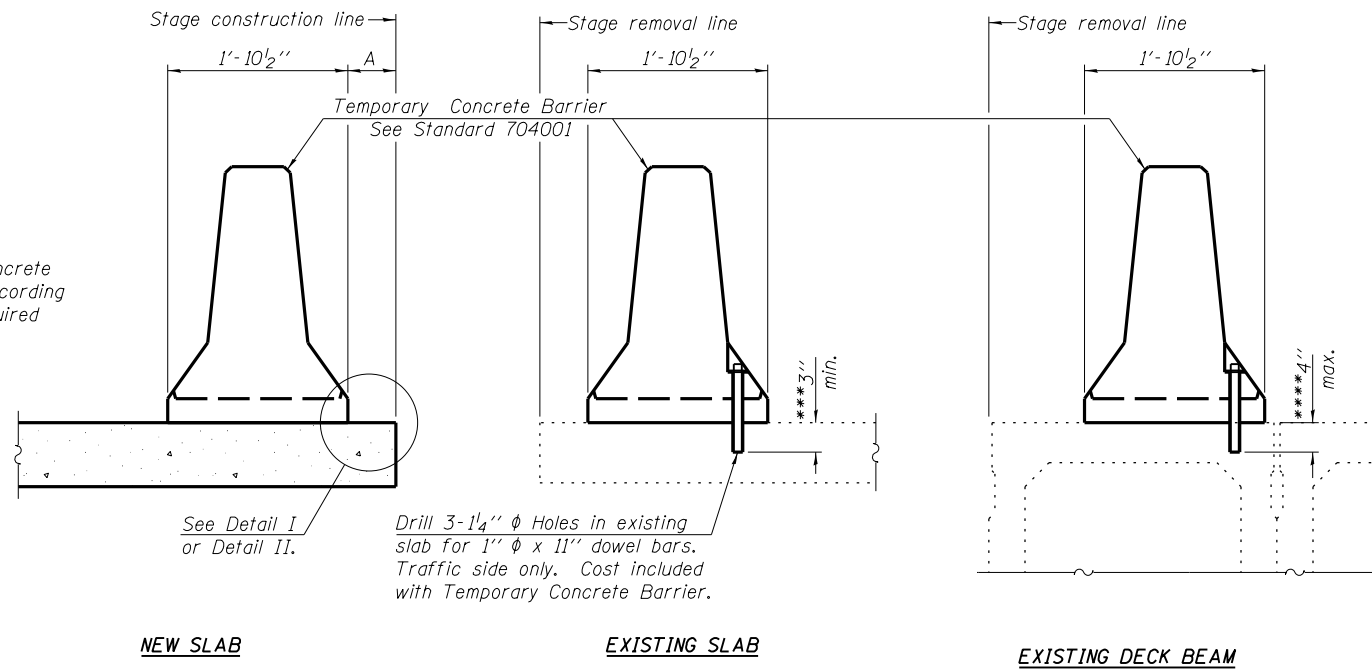

SECTIONS THRU SLAB OR DECK BEAM

NOTES

Detail I - With Bar Splicer or Couplers:
Connect one (1) 1" x 7" x "W" steel PL to the top layer of couplers with 2-5/8" phi bolts screwed to coupler at approximate C of each barrier panel.

Detail II - With Extended Reinforcement Bars:
Connect one (1) 1" x 7" x "W" steel PL to the concrete slab or concrete wearing surface with 2-5/8" phi Expansion Anchors or cast in place inserts spaced between the top layer of reinforcement at approximate C of each barrier panel.

Cost of anchorage is included with Temporary Concrete Barrier. The 1" x 7" x "W" plate shall not be removed until stage II construction forms and all reinforcement bars are in place and the concrete is ready to be placed.

*** Dimension shown is minimum required embedment into concrete. If hot-mix asphalt wearing surface is present, minimum embedment shall be in addition to wearing surface depth.

**** If existing deck beam is to remain in place after stage construction, embedment shall only be into wearing surface and not into existing deck beam concrete.

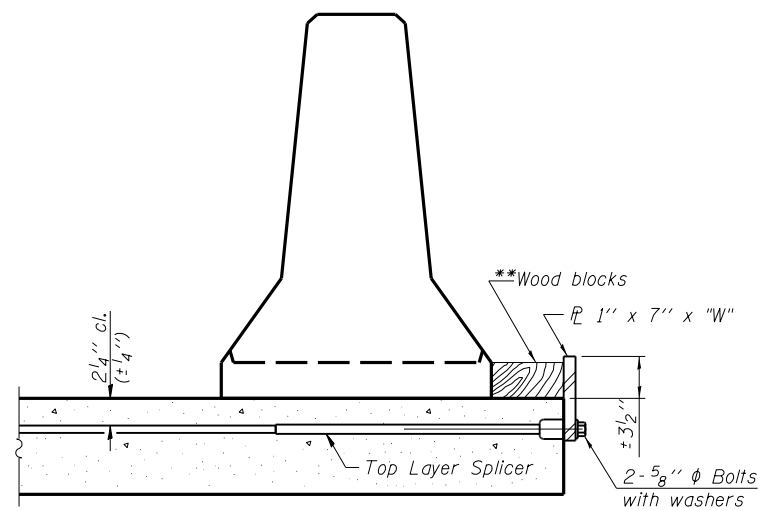

DETAIL I

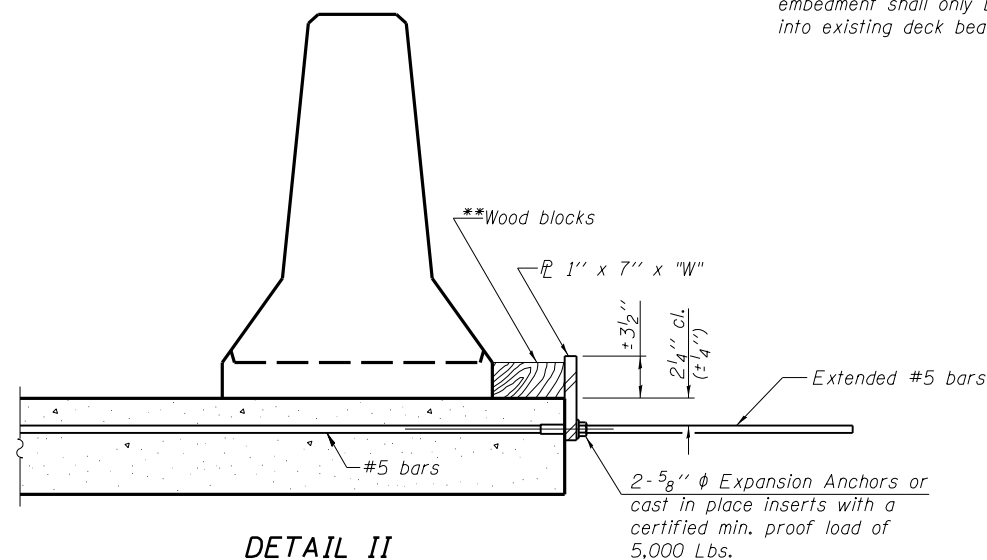

DETAIL II

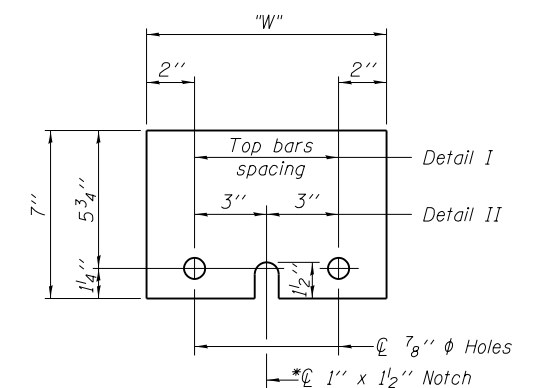

STEEL RETAINER PL 1" x 7" x "W"

* Required only with Detail II

** Wood blocks may be omitted when required to provide minimum stage traffic lane width. When the wood blocks are omitted, the concrete barrier shall be in direct contact with the steel retainer plate.

"W" = Top bars spacing + 4"

R-27 7-1-10
BENTON & ASSOCIATES, INC.

FILE NAME = P:\10e2166-2\Design\	USER NAME =	DESIGNED - MBH	REVISED -
Plans\082-0154 & 082-0155		CHECKED - SJH	REVISED -
0820154-76022-003-Barrier.dgn	PLOT SCALE =	DRAWN - MBH	REVISED -
	PLOT DATE =	CHECKED - SJH	REVISED -

STATE OF ILLINOIS
DEPARTMENT OF TRANSPORTATION

TEMPORARY CONCRETE BARRIER FOR STAGE CONSTRUCTION
STRUCTURE NO. 082-0154 & 082-0155

SHEET NO. 4 OF 10 SHEETS

F.A.I. RTE.	SECTION	COUNTY	TOTAL SHEETS	SHEET NO.
64	82-1HB1-2	ST. CLAIR	208	141
CONTRACT NO. 76022				
FED. ROAD DIST. NO. 8 ILLINOIS FED. AID PROJECT				

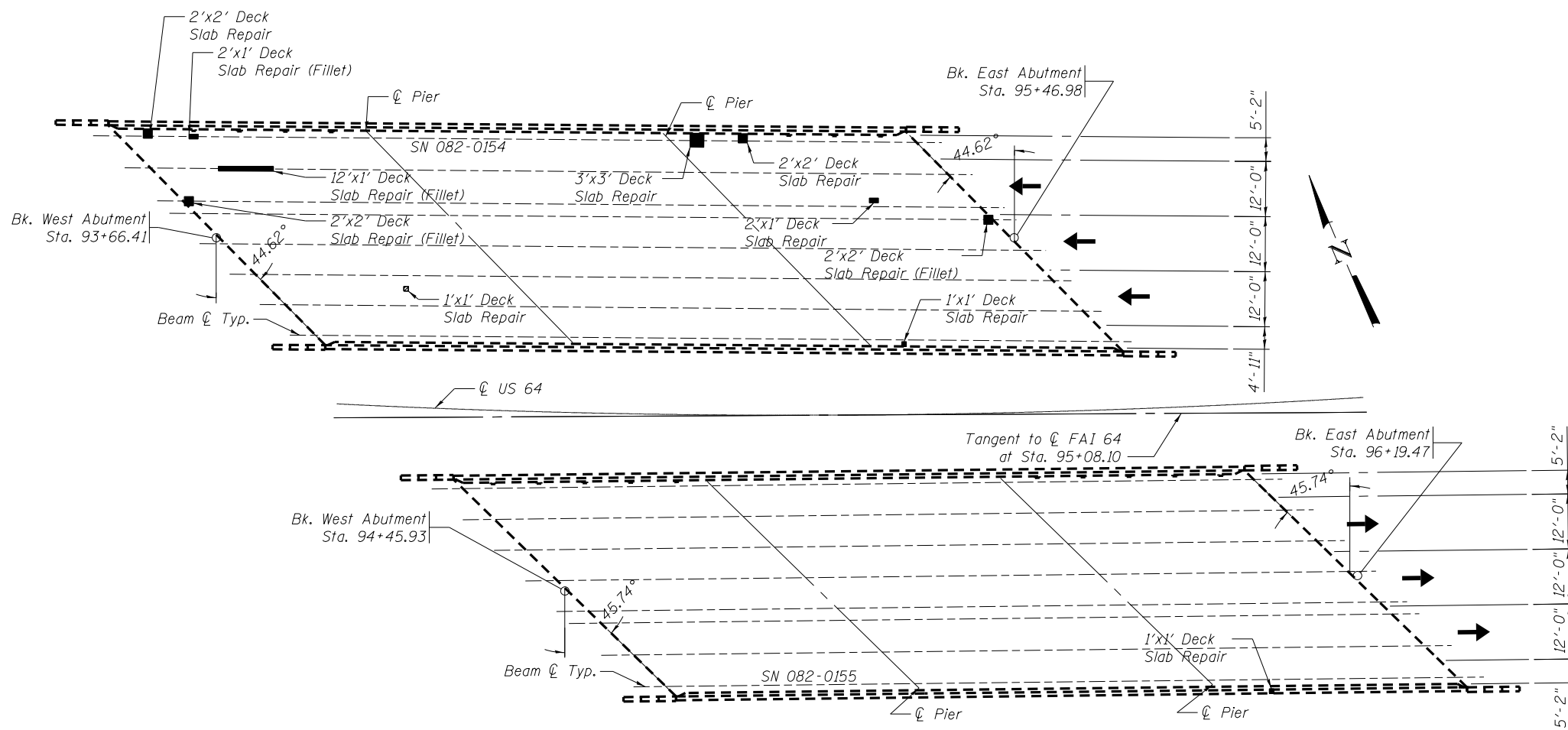

DECK REPAIR PLAN

LEGEND

- Area of Partial Depth Deck Repair
- Area of Full Depth Deck Repair

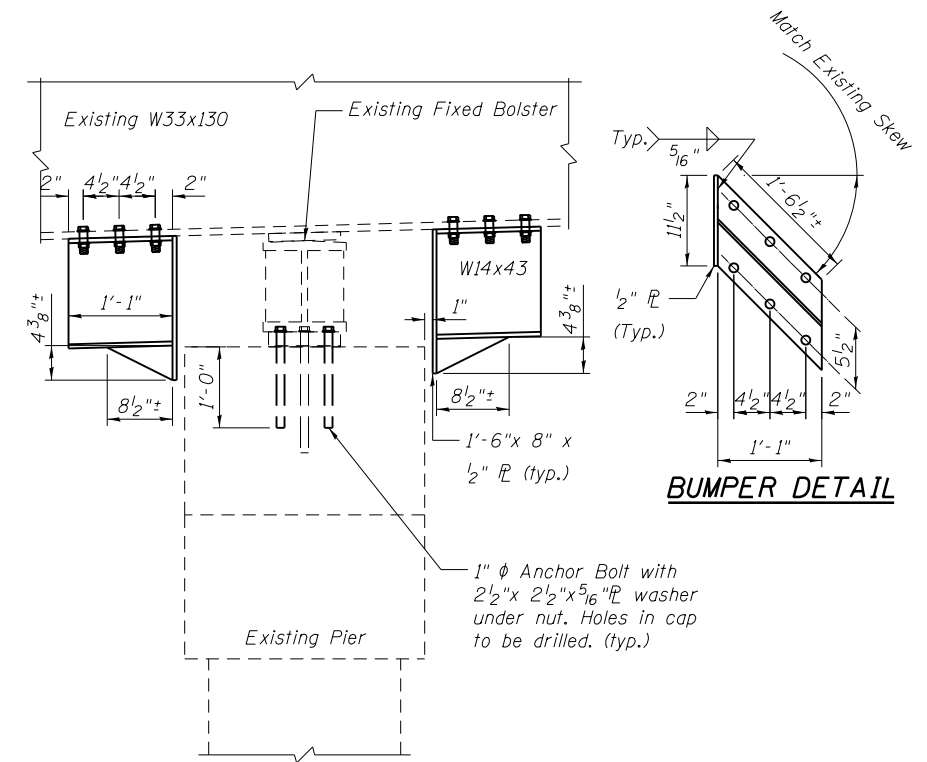

NEW BUMPERS

(At Existing Fixed Bearing Bolster on West Pier on both structures)

Notes:

The retainer angles shall be galvanized after shop fabrication according to AASHTO M 232.

Anchor bolts and plate washers shall be galvanized according to AASHTO M 232.

BILL OF MATERIAL

ITEM	UNIT	QUANTITY
Furnishing and Erecting Structural Steel	Pound	3160
Deck Slab Repair (Full)	Sq. Yd.	4.8
Deck Slab Repair (Partial)	Sq. Yd.	0.1
Anchor Bolt, 1"	Each	64

BENTON & ASSOCIATES, INC.

FILE NAME = P:\10e2166-2\Design\	USER NAME =	DESIGNED - MBH	REVISED - 10/3/13
Plans\082-0154 & 082-0155		CHECKED - SJH	REVISED - _____
0820154-76022-004-Deck.dgn	PLOT SCALE =	DRAWN - MBH	REVISED - _____
	PLOT DATE =	CHECKED - SJH	REVISED - _____

**STATE OF ILLINOIS
DEPARTMENT OF TRANSPORTATION**

**DECK REPAIRS
STRUCTURE NO. 082-0154 & 082-0155**

SHEET NO. 5 OF 10 SHEETS

F.A.I. RTE.	SECTION	COUNTY	TOTAL SHEETS	SHEET NO.
64	82-1HB1-3	ST. CLAIR	208	142
CONTRACT NO. 76022				
FED. ROAD DIST. NO. 8 ILLINOIS FED. AID PROJECT				

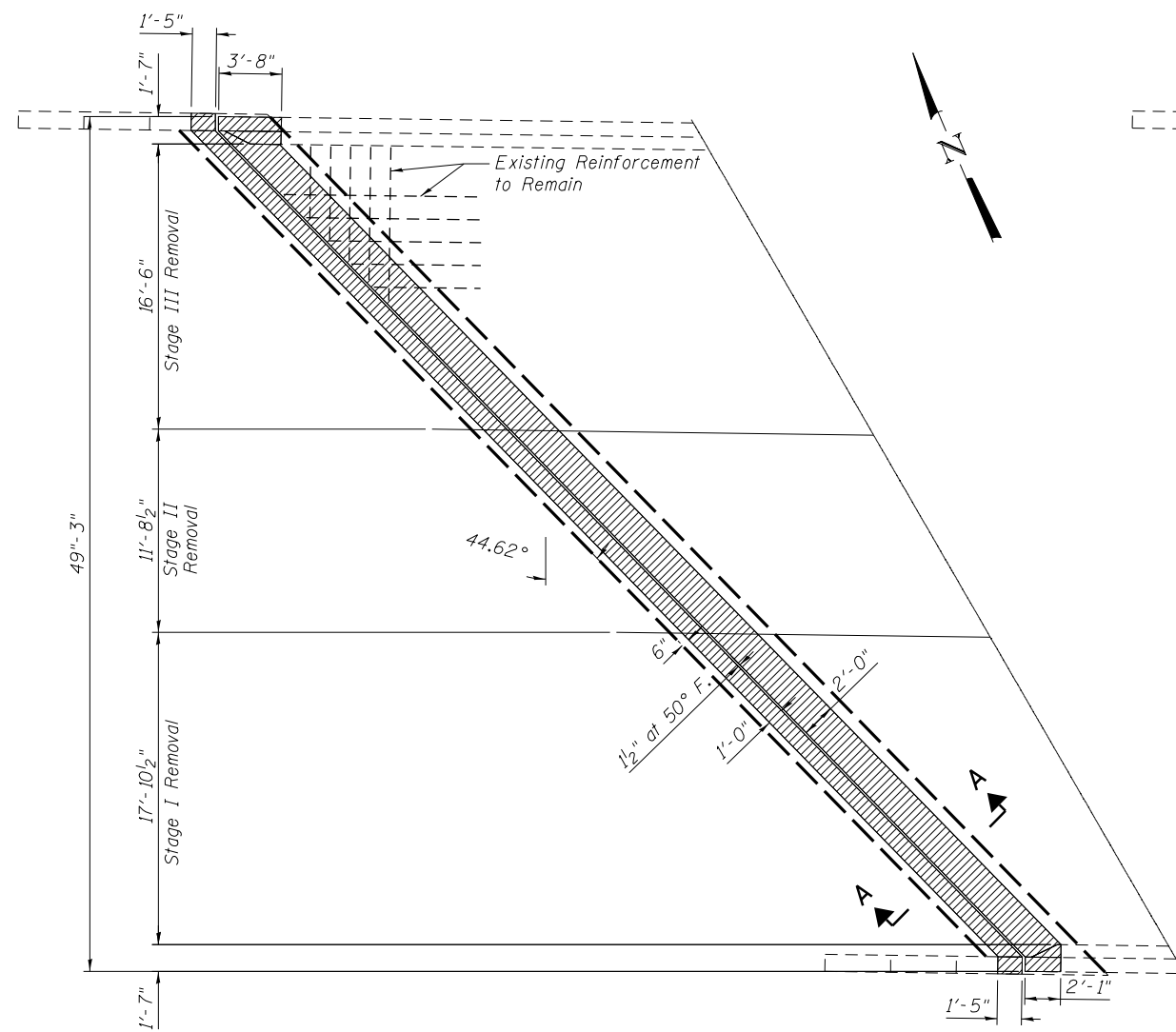

CONCRETE REMOVAL
(West Abut. shown)
(East Abut. similar)

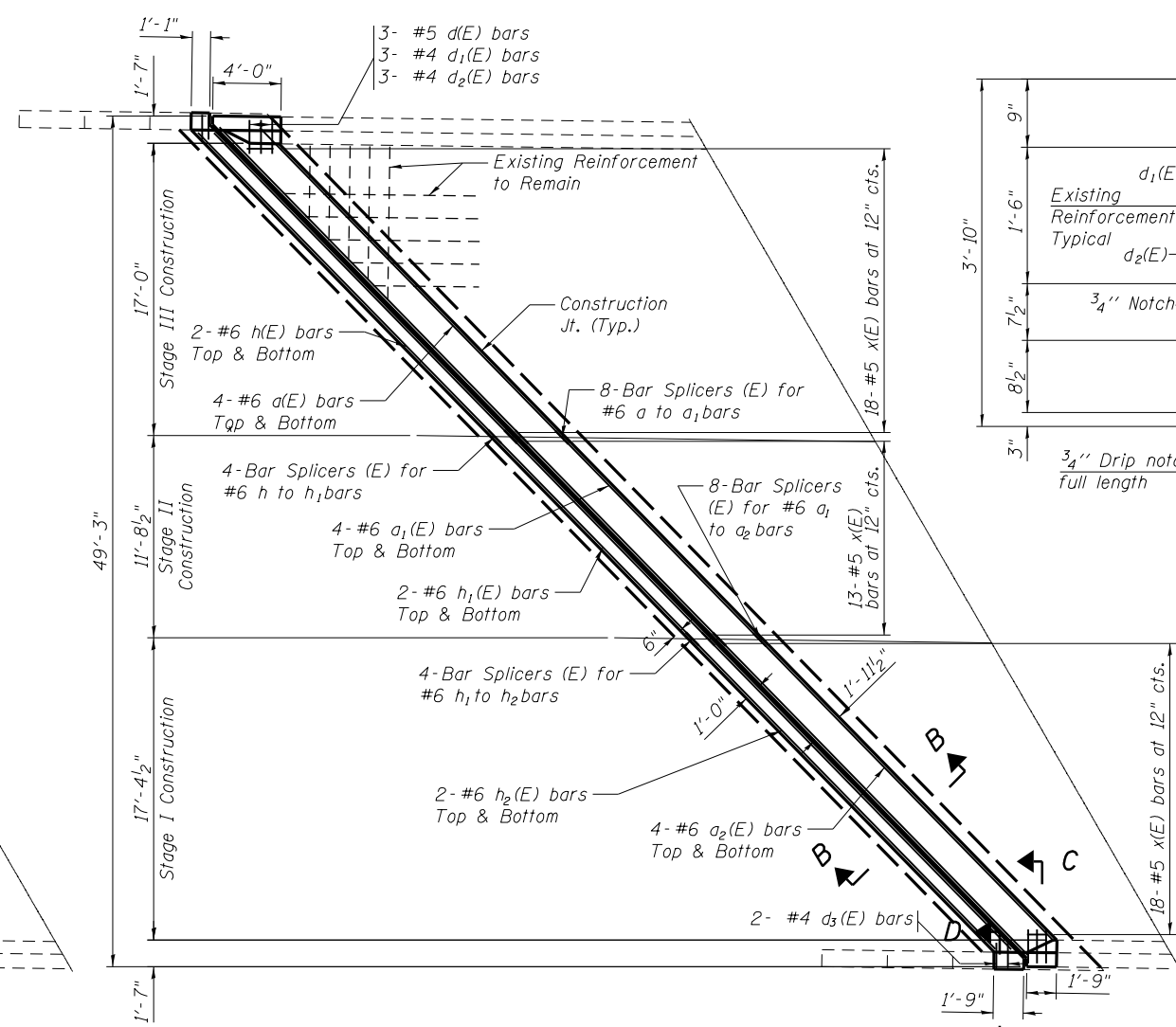

CONCRETE REPLACEMENT
(West Abut. shown)
(East Abut. similar)

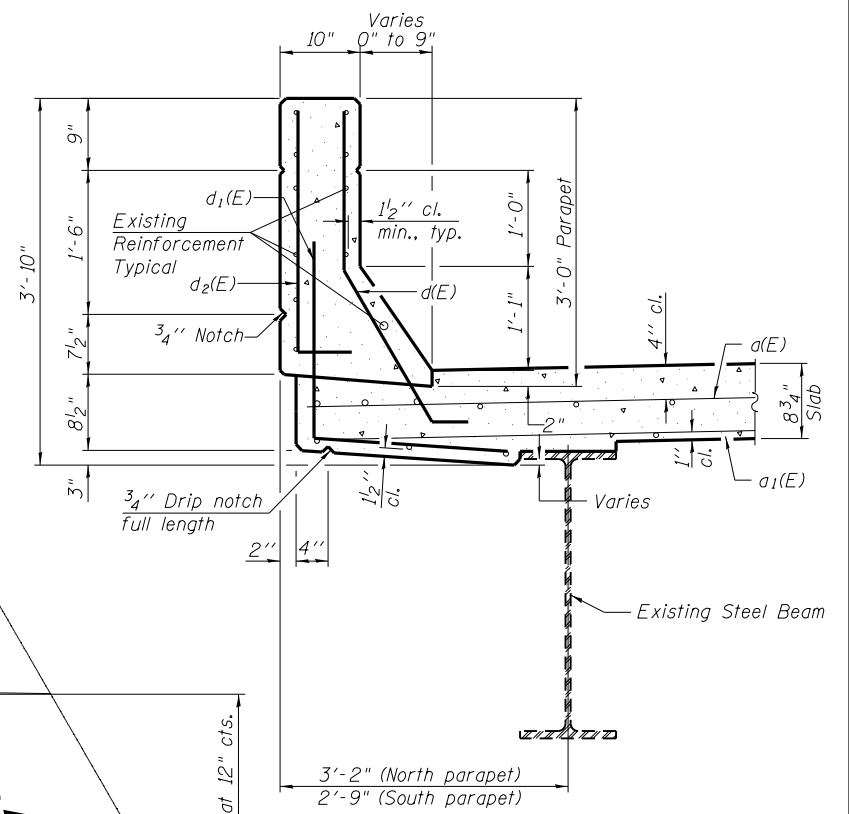

SECTION C-C

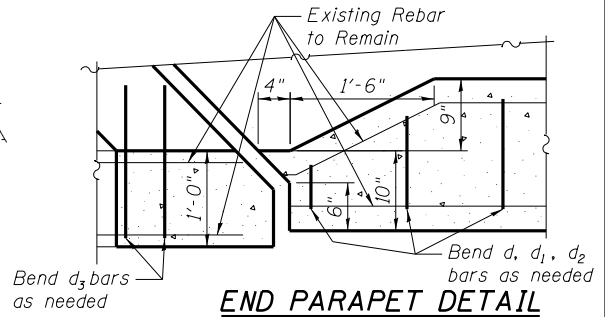

END PARAPET DETAIL

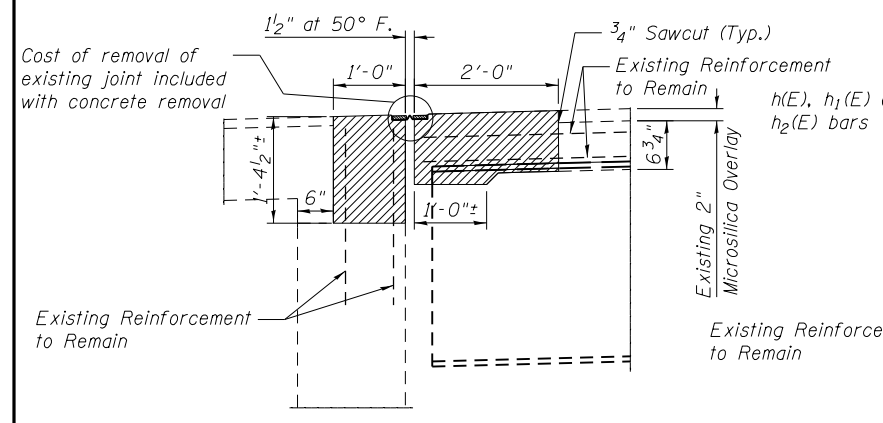

SECTION A-A

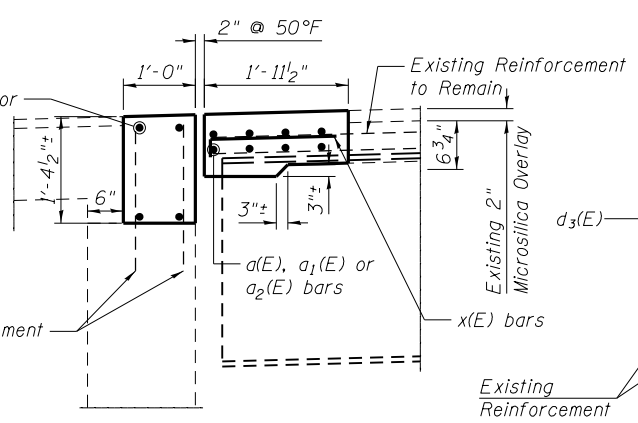

SECTION B-B

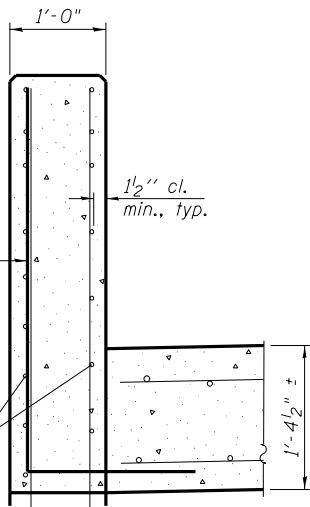

SECTION D-D

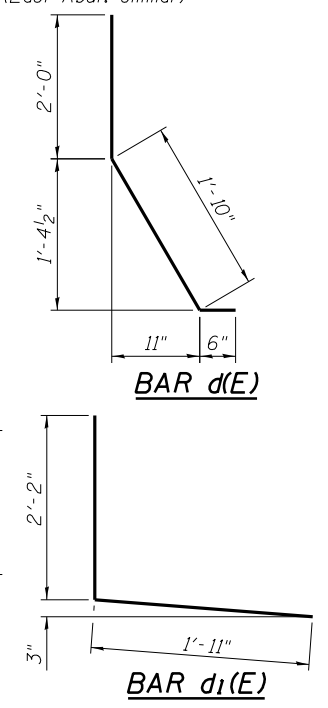

BAR d1(E)

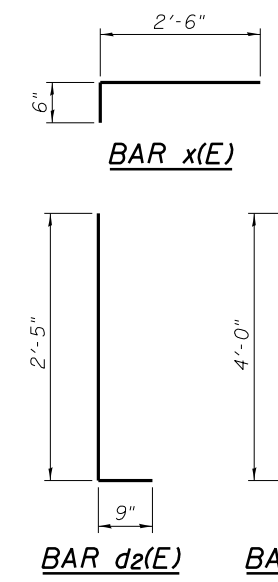

BAR d2(E)

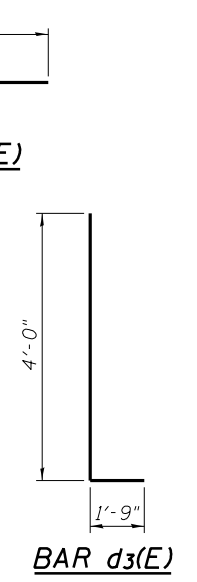

BAR d3(E)

BAR x(E)

SUPERSTRUCTURE BILL OF MATERIAL

Bar	No.	Size	Length	Shape
a(E)	16	#6	25'-2"	—
a1(E)	16	#6	16'-6"	—
a2(E)	16	#6	25'-9"	—
d(E)	12	#5	4'-4"	┌
d1(E)	12	#4	4'-1"	┌
d2(E)	12	#4	3'-2"	┌
d3(E)	8	#4	5'-9"	┌
h(E)	8	#6	25'-0"	—
h1(E)	8	#6	16'-6"	—
h2(E)	8	#6	25'-6"	—
x(E)	98	#5	3'-0"	┌
Bar Splicers			Each	48
Reinforcement Bars, Epoxy Coated			Pound	2880
Concrete Superstructure			Cu. Yds.	17.6
Concrete Removal			Cu. Yds.	17.8
Preformed Strip Seal			Foot	141

BENTON & ASSOCIATES, INC.

FILE NAME = P:\10e2166-2\ Design\	USER NAME =	DESIGNED - MBH	REVISED - 10/3/13
Plans\ 082-0154 & 082-0155		CHECKED - SJH	REVISED -
0820154-76022-005-Joint.dgn	PLOT SCALE =	DRAWN - MBH	REVISED -
	PLOT DATE	CHECKED - SJH	REVISED -

**STATE OF ILLINOIS
DEPARTMENT OF TRANSPORTATION**

**CONCRETE REMOVAL & REPLACEMENT
STRUCTURE NO. 082-0154**

SHEET NO. 6 OF 10 SHEETS

F.A.I. RTE.	SECTION	COUNTY	TOTAL SHEETS	SHEET NO.
64	82-1HB1-3	ST. CLAIR	208	143
CONTRACT NO. 76022				
FED. ROAD DIST. NO. 8 ILLINOIS FED. AID PROJECT				

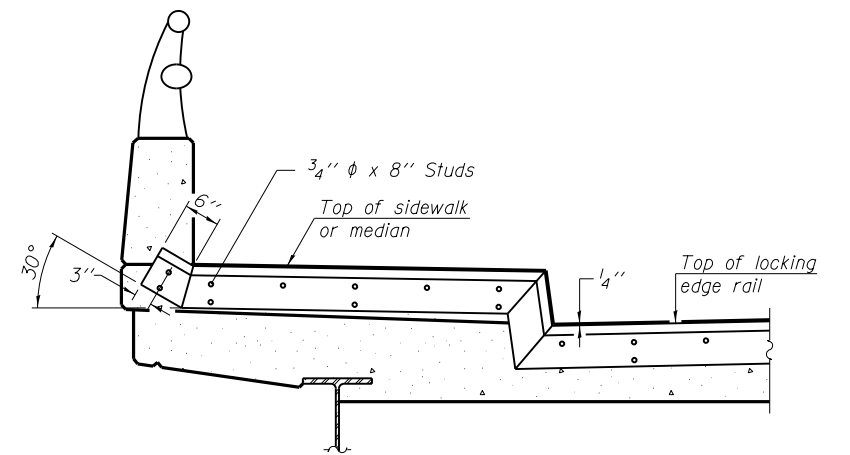
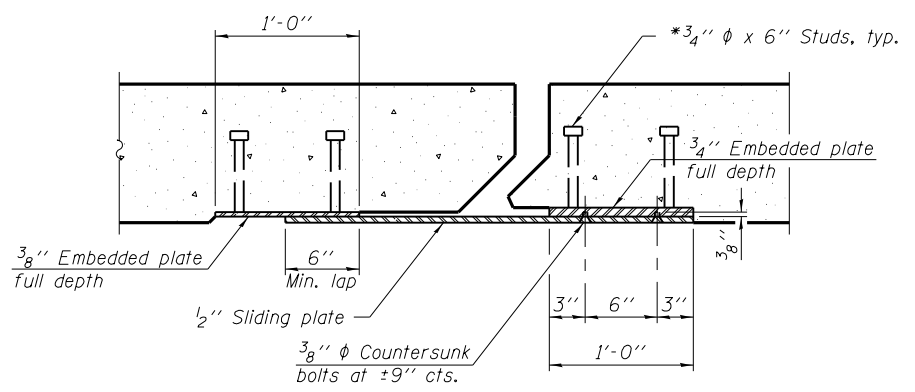
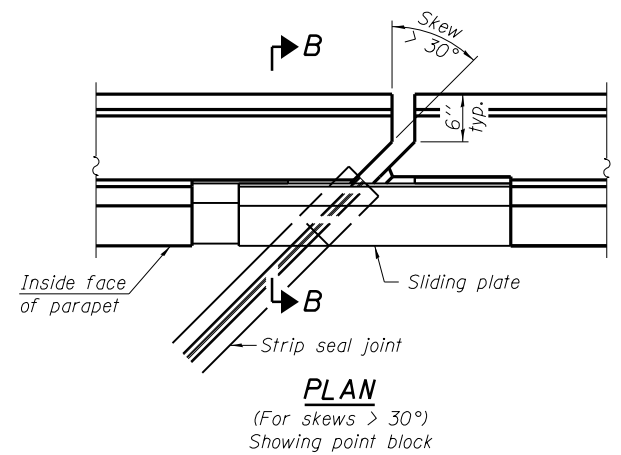
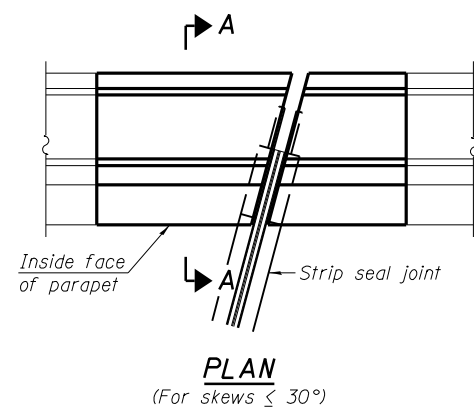

TYPICAL END TREATMENT AT SIDEWALK OR MEDIAN
 Shorter plates with a single row of studs at 12" cts. may be necessary on medians which are shallower than 9". See manufacturer's recommendation.

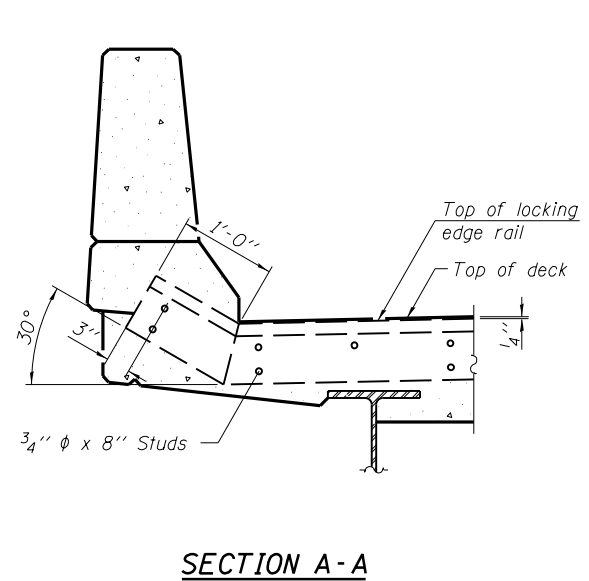

SECTION A-A

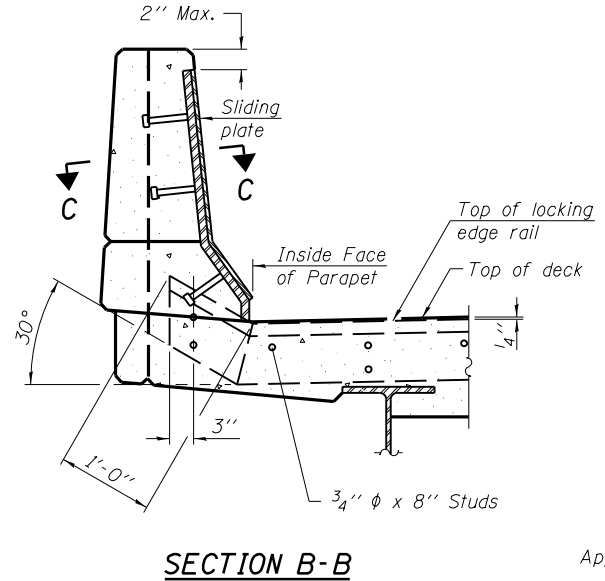

SECTION B-B

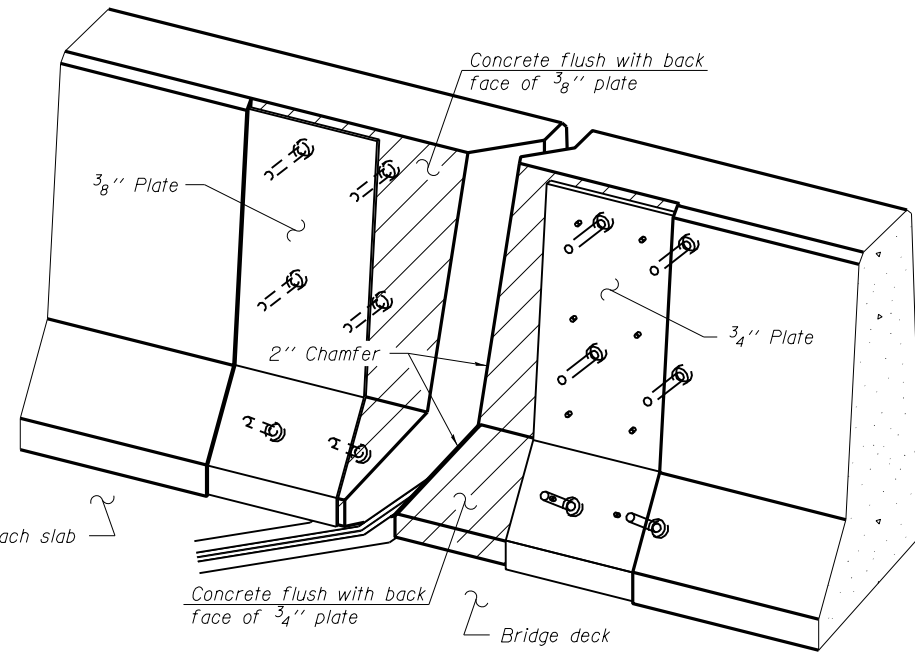

TRIMETRIC VIEW (Showing back plates only)

Notes:
 The strip seal shall be made continuous and shall have a minimum thickness of 1/4". The configuration of the strip seal shall match the configuration of the Locking Edge Rails. Open or "webbed" strip seal gland configurations are not permitted. The gland shall be sized for a maximum rated movement of 4 inches.
 The Locking Edge Rails depicted are conceptual only, except for the minimum dimensions shown. The actual configuration of the Locking Edge Rails and matching strip seal may vary from manufacturer to manufacturer. Flanged edge rails will not be allowed. Locking Edge Rails may be spliced at slope discontinuities.
 The manufacturer's recommended installation methods shall be followed.
 The joint opening and deck dimensions detailed on the superstructure are based on a rolled rail expansion joint. If the Contractor elects to use the welded rail expansion joint, the opening and deck dimensions shall be modified according to the dimensions detailed on this sheet. Required modifications shall be made at no additional cost to the State.
 All steel components shall be galvanized after fabrication according to Article 520.03 of the Standard Specifications.
 Maximum space between rail segments at stage lines shall be 3/16", sealed with a suitable sealant.
 Parapet plates and anchorage studs for skews > 30 degrees included in the cost of Preformed Joint Strip Seal.

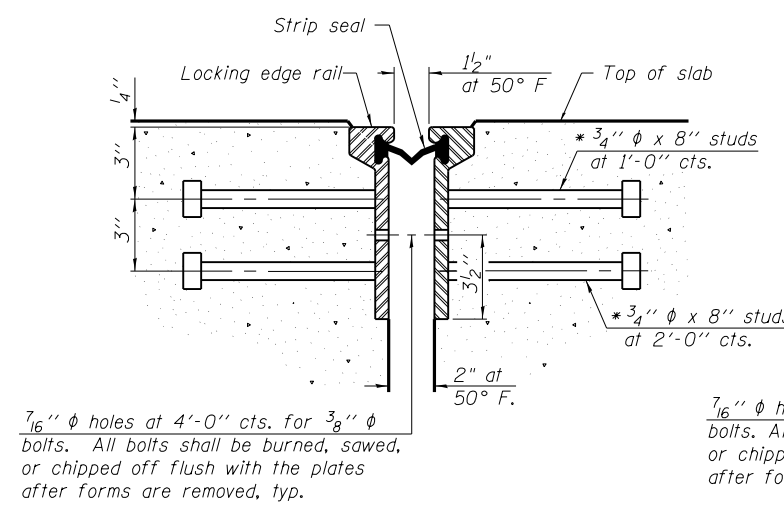

SECTION THRU ROLLED RAIL JOINT

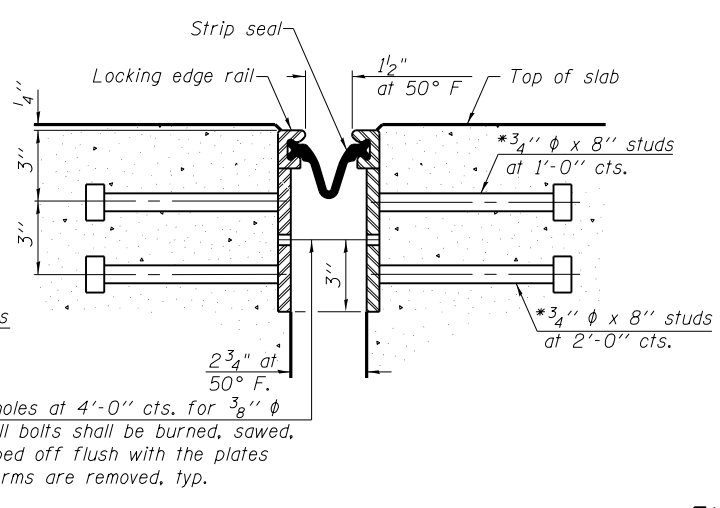

SECTION THRU WELDED RAIL JOINT

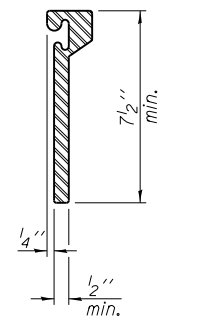

ROLLED EXTRUDED RAIL

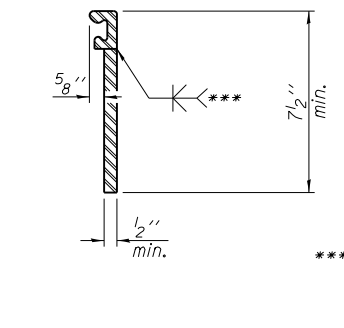

WELDED RAIL

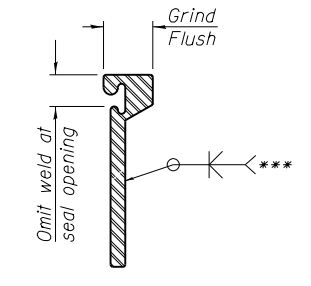

LOCKING EDGE RAIL SPLICE

The inside of the locking edge rail groove shall be free of weld residue.
 Rolled rail shown, welded rail similar.

LOCKING EDGE RAILS

BILL OF MATERIAL

Item	Unit	Total
Preformed Joint Strip Seal	Foot	282

EJ-SSJ 7-1-10
BENTON & ASSOCIATES, INC.

* Granular or solid flux filled headed studs conforming to Article 1006.32 of the Std. Specs., automatically end welded.

FILE NAME = P:\10e2166-2\ Design\ Plans\ 082-0154 & 082-0155	USER NAME =	DESIGNED - MBH	REVISED -
0820154-76022-007-Joint.dgn	PLOT SCALE =	CHECKED - SJH	REVISED -
	PLOT DATE	DRAWN - MBH	REVISED -
		CHECKED - SJH	REVISED -

STATE OF ILLINOIS
DEPARTMENT OF TRANSPORTATION

PREFORMED JOINT STRIP SEAL
STRUCTURE NO. 082-0154 & 082-0155

SHEET NO. 8 OF 10 SHEETS

F.A.I. RTE.	SECTION	COUNTY	TOTAL SHEETS	SHEET NO.
64	82-1HB1-2	ST. CLAIR	208	145
CONTRACT NO. 76022				
FED. ROAD DIST. NO. 8 ILLINOIS FED. AID PROJECT				

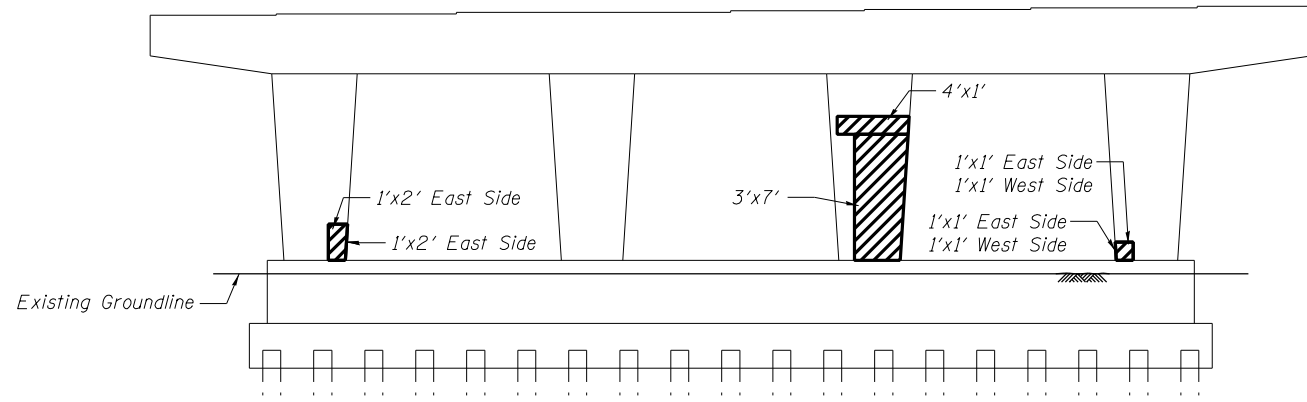

STRUCTURE 082-0155 WEST PIER
(Looking East)

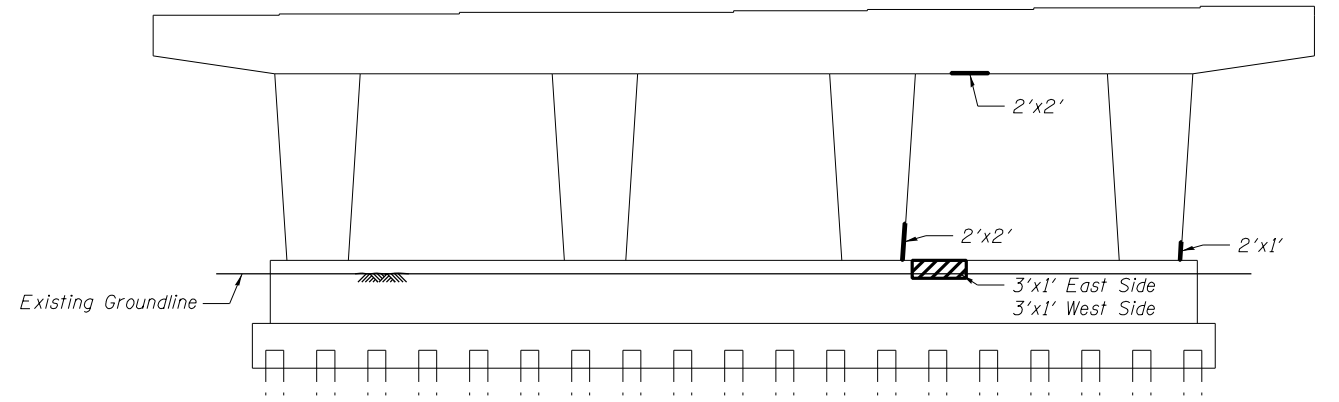

STRUCTURE 082-0155 EAST PIER
(Looking East)

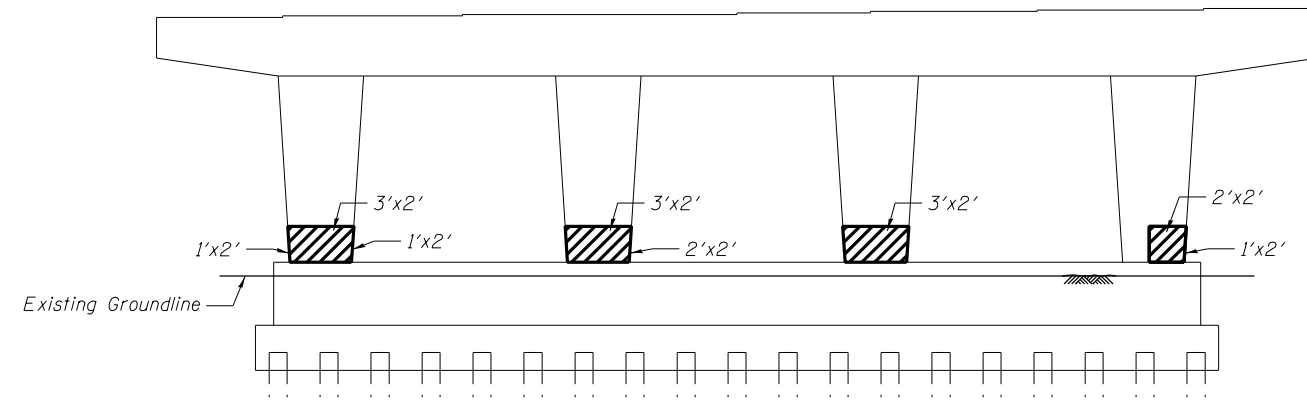

STRUCTURE 082-0154 EAST PIER
(Looking East)

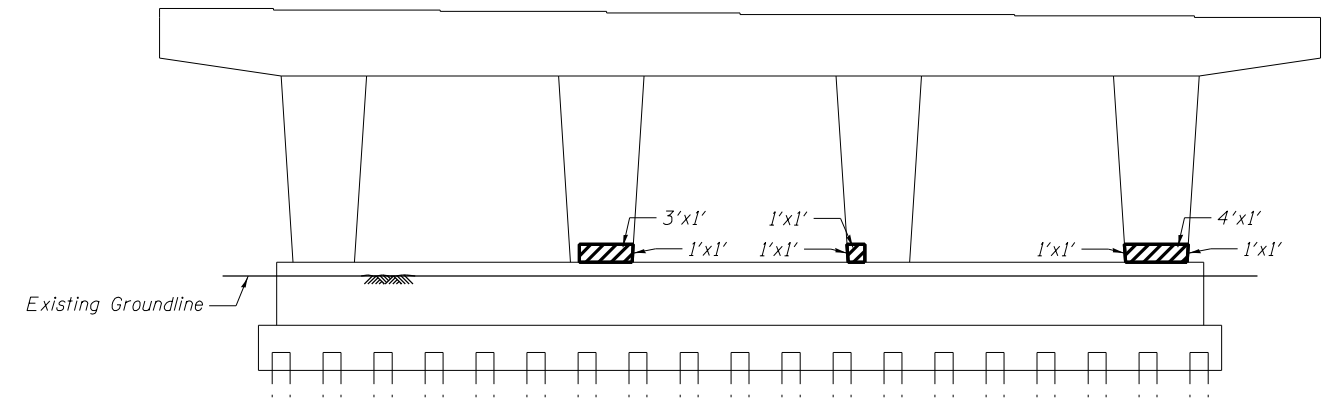

STRUCTURE 082-0154 EAST PIER
(Looking West)

LEGEND

▨ Area of Structural Concrete Repair

BILL OF MATERIAL

Item	Unit	Total
Structural Repair of Concrete (Depth <= 5")	Sq. Ft.	93

BENTON & ASSOCIATES, INC.

FILE NAME = P:\10e2166-2\Design\	USER NAME =	DESIGNED - MBH	REVISED -
Plans\ 082-0154 & 082-0155		CHECKED - SJH	REVISED -
0820154-76022-008-Piers.dgn	PLOT SCALE =	DRAWN - MBH	REVISED -
	PLOT DATE =	CHECKED - SJH	REVISED -

**STATE OF ILLINOIS
DEPARTMENT OF TRANSPORTATION**

**SUBSTRUCTURE REPAIRS
STRUCTURE NO. 082-0154 & 082-0155**

SHEET NO. 9 OF 10 SHEETS

F.A.I. RTE.	SECTION	COUNTY	TOTAL SHEETS	SHEET NO.
64	82-1VBI / 82-1VBR	ST. CLAIR	208	146
CONTRACT NO. 76022				
FED. ROAD DIST. NO. 8 ILLINOIS FED. AID PROJECT				

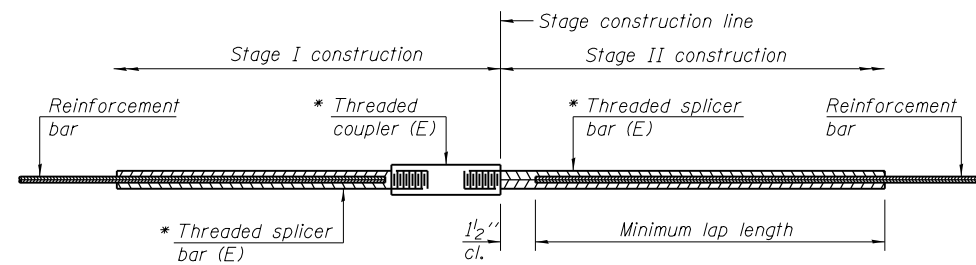

STANDARD BAR SPLICER ASSEMBLY

Minimum Lap Lengths					
Bar size to be spliced	Table 1	Table 2	Table 3	Table 4	Table 5
3, 4	1'-5"	1'-11"	2'-1"	2'-4"	2'-3"
5	1'-9"	2'-5"	2'-7"	2'-11"	2'-10"
6	2'-1"	2'-11"	3'-1"	3'-6"	3'-4"
7	2'-9"	3'-10"	4'-2"	4'-8"	4'-6"
8	3'-8"	5'-1"	5'-5"	6'-2"	5'-10"
9	4'-7"	6'-5"	6'-10"	7'-9"	7'-5"

- Table 1: Black bar, 0.8 Class C
- Table 2: Black bar, Top bar lap, 0.8 Class C
- Table 3: Epoxy bar, 0.8 Class C
- Table 4: Epoxy bar, Top bar lap, 0.8 Class C
- Table 5: Epoxy bar, Top bar lap, Class B

Threaded splicer bar length = min. lap length + 1/2" + thread length

* Epoxy not required on Bar Splicer Assembly components used in conjunction with black bars.

Location	Bar size	No. assemblies required	Table for minimum lap length
SN 082-0154 Deck	#6	16	Table 3
SN 082-0154 Deck	#6	16	Table 3
SN 082-0154 Hatch	#6	8	Table 3
SN 082-0154 Hatch	#6	8	Table 3
SN 082-0155 Deck	#6	32	Table 3
SN 082-0155 Hatch	#6	16	Table 3

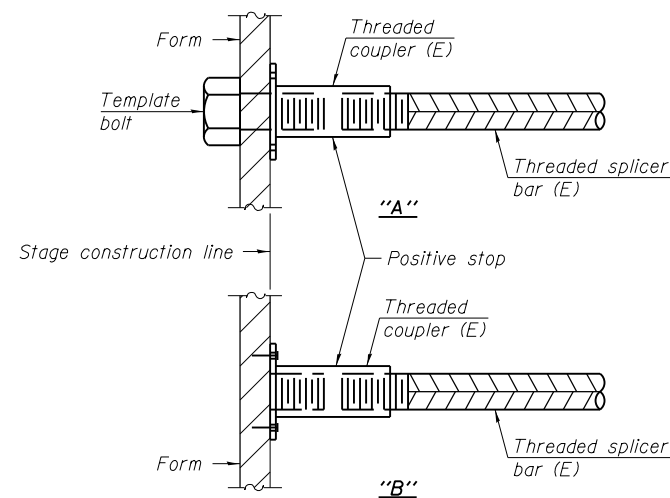

INSTALLATION AND SETTING METHODS

"A" : Set bar splicer assembly by means of a template bolt.
 "B" : Set bar splicer assembly by nailing to wood forms or cementing to steel forms.
 (E) : Indicates epoxy coating.

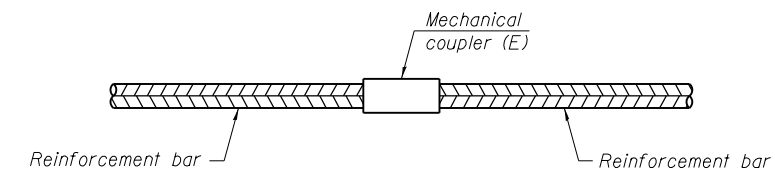

STANDARD MECHANICAL SPLICER

Location	Bar size	No. assemblies required

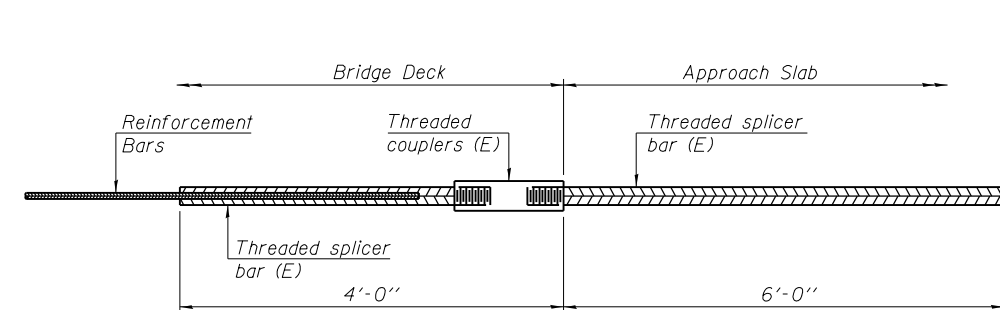

BAR SPLICER ASSEMBLY FOR #5 BAR ON INTEGRAL OR SEMI-INTEGRAL ABUTMENTS

No. required =

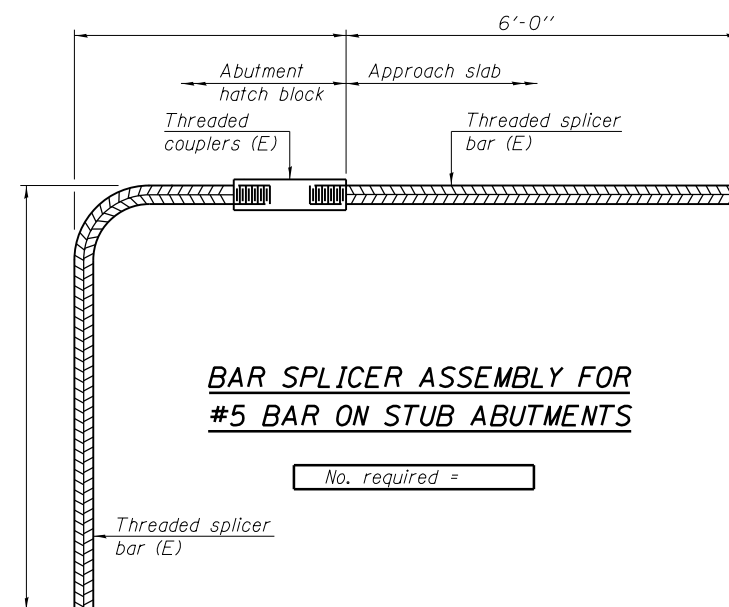

BAR SPLICER ASSEMBLY FOR #5 BAR ON STUB ABUTMENTS

No. required =

NOTES

- Splicer bars shall be deformed with threaded ends and have a minimum 60 ksi yield strength.
- All reinforcement shall be lapped and tied to the splicer bars.
- Bar splicer assemblies shall be epoxy coated according to the requirements for reinforcement bars. See Section 508 of the Standard Specifications.
- See special provision for Mechanical Splicers.
- See approved list of bar splicer assemblies and mechanical splicers for alternatives.

BSD-1 7-1-10
 BENTON & ASSOCIATES, INC.

FILE NAME = P:\10e2166-2\ Design\ Plans\ 082-0154 & 082-0155 0820154-76022-009-Splicer.dgn	USER NAME =	DESIGNED - MBH	REVISED - 10/3/13
	PLOT SCALE =	CHECKED - SJH	REVISED -
	PLOT DATE =	DRAWN - MBH	REVISED -
		CHECKED - SJH	REVISED -

STATE OF ILLINOIS
 DEPARTMENT OF TRANSPORTATION

BAR SPLICER ASSEMBLY AND MECHANICAL SPLICER DETAILS
 STRUCTURE NO. 082-0154 & 082-0155

SHEET NO. 10 OF 10 SHEETS

F.A.I. RTE.	SECTION	COUNTY	TOTAL SHEETS	SHEET NO.
64	82-1HB1-3	ST. CLAIR	208	147
CONTRACT NO. 76022				
FED. ROAD DIST. NO. 8 ILLINOIS FED. AID PROJECT				

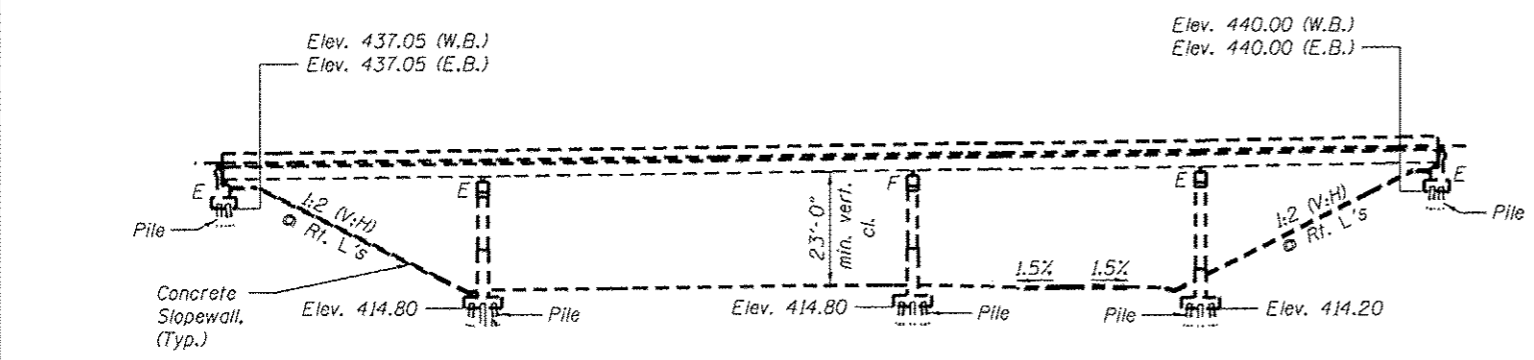

ELEVATION

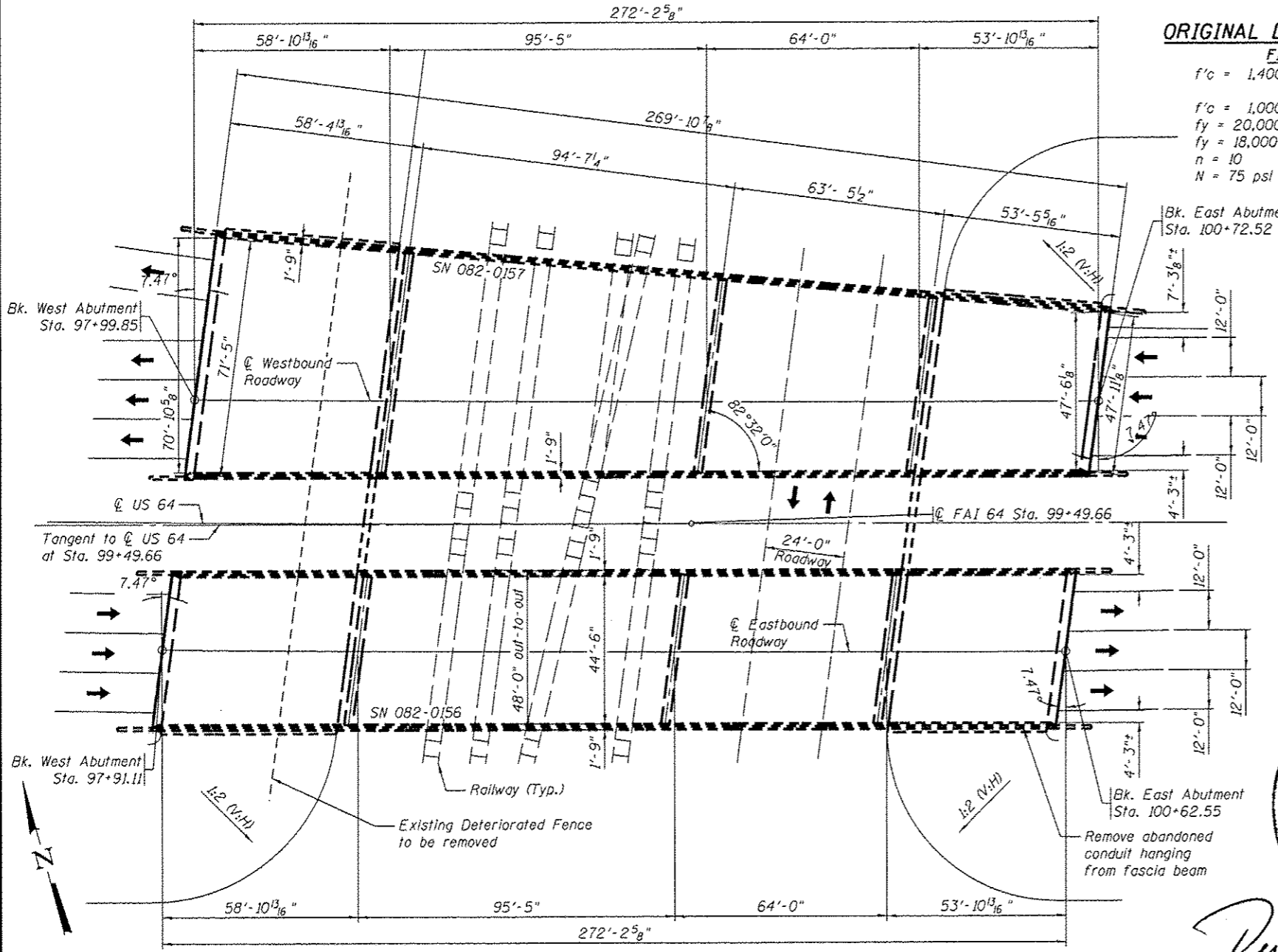

PLAN

TOTAL BILL OF MATERIAL

ITEM	UNIT	QUANTITY
Concrete Removal	Cu. Yd.	29.6
Concrete Superstructure	Cu. Yd.	29.3
Bridge Deck Concrete Sealer	Sq. Ft.	32580
Furnishing and Erecting Structural Steel	Pound	7270
Reinforcement Bars, Epoxy Coated	Pound	4270
Preformed Joint Strip Seal	Foot	224
Deck Slab Repair (Full)	Sq. Yd.	5.0
Deck Slab Repair (Partial)	Sq. Yd.	0.8
Structural Repair of Concrete (Depth <= 5")	Sq. Ft.	42
Bar Splicers	Each	96
Remove Existing Conduit Attached to Structure	Foot	272
Fence Removal	Foot	192
Anchor Bolts, 1"	Sq. Yd.	80

ORIGINAL DESIGN STRESSES

FIELD UNITS
 $f'_c = 1,400$ psi (Superstructure & Substructure without earth pressure)
 $f'_c = 1,000$ psi (Substructure with Earth Pressure)
 $f_y = 20,000$ psi (Reinforcement)
 $f_y = 18,000$ psi (Structural Steel A36)
 $n = 10$
 $N = 75$ psi

FAI 64 CURVE DATA

(Spiral Curve)
 PI STA. = 88+63.12
 $\Delta = 30^\circ 24' 20''$
 $\Delta_c = 27^\circ 24' 20''$
 $D_c = 1^\circ 30' 0''$
 $R_c = 3,819.72'$
 $L_c = 1827.04'$
 $L_s = 200.00'$
 $\theta_s = 1^\circ 30' 0''$
 $T_s = 1138.11'$
 $E_s = 138.98'$
 $S.E. = 0.01'/FT.$

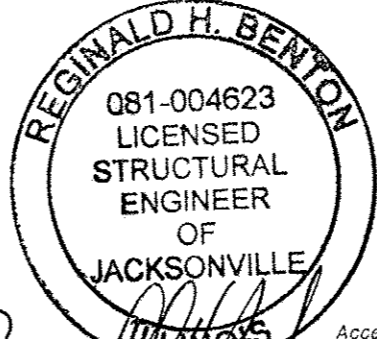

Reginald H. Benton
 8/20/13 EXP 11/30/14

INDEX OF SHEETS

General Plan & Elevation	1
Staging	2-3
Temporary Concrete Barrier For Stage Construction	4
Deck Repairs	5
Concrete Removal & Replacement	6-8
Preformed Joint Strip Seal	9
Substructure Repairs	10
Bar Splicer Assembly Details	11

GENERAL NOTES

- All new structural steel shall conform to AASHTO Classification M270 Gr. 36 unless otherwise noted.
- Fasteners shall be AASHTO M164 Type 1, mechanically galvanized bolts (in painted areas and M164 Type 3 in unpainted areas). Bolts $\frac{7}{8}$ " ϕ , holes $\frac{15}{16}$ " ϕ , unless otherwise noted.
- No field welding is permitted except as specified in the contract documents.
- Reinforcement bars designated (E) shall be epoxy coated.
- Prior to pouring the new concrete deck, all heavy or loose rust, loose mill scale, and other loose or potentially detrimental foreign material shall be removed from the surfaces in contact with concrete. Tightly adhered paint may remain unless otherwise noted. Removal shall be accomplished by methods that will not damage the steel and the cost will be included in the pay item covering removal of the existing concrete.
- As directed by the Engineer, existing construction accessories welded to the top flange of beams and girders shall be removed. The weld areas shall be ground flush and inspected for cracks using magnetic particle testing (MT) or dye penetrant testing (PT) by qualified personnel approved by the Engineer. Any cracks that can not be removed by grinding $\frac{1}{4}$ in. deep shall be identified and reported to the Bureau of Bridges and Structures for further disposition. The cost of removing welded accessories, grinding and inspecting weld areas and grinding cracks will be paid for according to Article 109.04 of the Standard Specifications.
- Plan dimensions and details relative to existing plans are subject to nominal construction variations. The Contractor shall field verify existing dimensions and details affecting new construction and make necessary approved adjustments prior to construction or ordering of materials. Such variations shall not be cause for additional compensation for a change in scope of the work, however, the Contractor will be paid for the quantity actually furnished at the unit price bid for the work.
- Existing reinforcement bars extended into the removal area shall be cleaned, straightened, and incorporated into the new construction. Any reinforcement bars that are damaged during concrete removal shall be replaced with approved bar silcer or anchorage system. Cost included with Concrete Removal.
- Joint openings shall be adjusted according to Article 520.04 of the Standard Specifications when the deck is poured at an ambient temperature other than 50°F.
- Areas of deck repairs shown are estimated. The Engineer shall show actual locations of deck repairs on As-built Plans.
- All structural steel shall be shop painted with inorganic zinc rich primer per AASHTO M300, Type 1. Color to match existing. Cost included with Furnishing and Erecting Structural Steel.
- The existing structural steel contains lead. The contractor shall take appropriate precautions to deal with the presence of lead on this project.
- Existing structural steel that will be in contact with new structural steel shall be cleaned and painted prior to erection as required by the Special Provisions "Cleaning & Painting Contact Surface Areas of Existing Steel Structures".

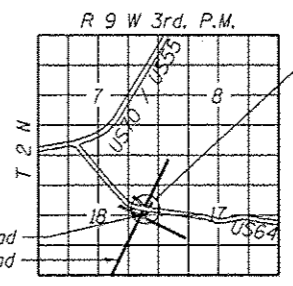

LOCATION SKETCH

GENERAL PLAN & ELEVATION
INTERSTATE 64 OVER RAILROAD
F.A.I. RTE. 64 - SEC. 82-IVBR-1
ST. CLAIR COUNTY
US 64 STA. 108+77.79
RAILROAD STA. 3+88.47

BENTON & ASSOCIATES, INC.

FILE NAME	USER NAME	DESIGNED	REVISIONS
P:\18a2166-2\ Design\		MBH	
P\ons\ 882-0156 & 882-0157		SJH	
8820156-76022-081-CPE.dgn		MBH	
		SJH	

STATE OF ILLINOIS
DEPARTMENT OF TRANSPORTATION

GENERAL PLAN & ELEVATION
STRUCTURE NO. 082-0156 & 082-0157

SHEET NO. 1 OF 11 SHEETS

F.A.I. RTE.	SECTION	COUNTY	TOTAL SHEETS	SHEET NO.
64	82-IVBR / 82-IVBR	ST. CLAIR	208	148
CONTRACT NO. 76022				
FED. ROAD DIST. NO. 8 ILLINOIS FED. AID PROJECT				

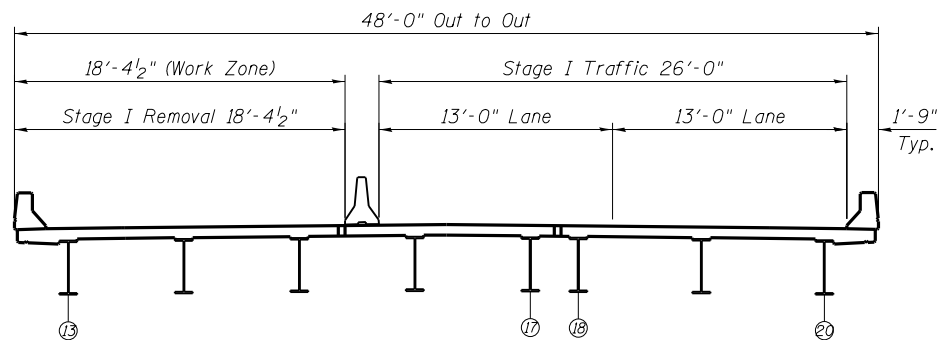

SN 082-0156 EASTBOUND CROSS SECTION
(Looking East)
STAGE I REMOVAL

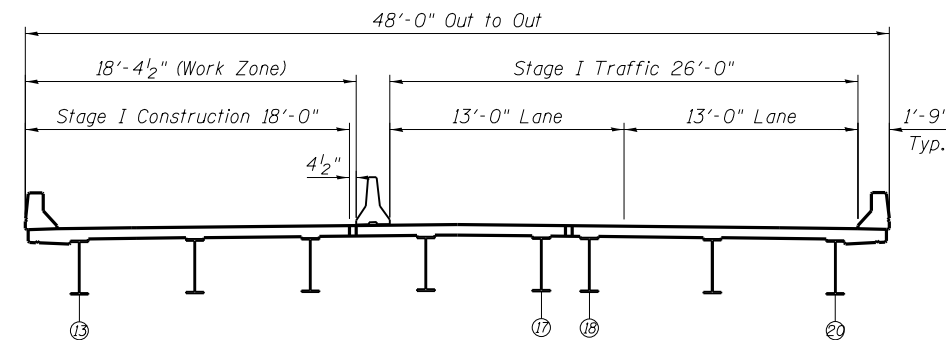

SN 082-0156 EASTBOUND CROSS SECTION
(Looking East)
STAGE I CONSTRUCTION

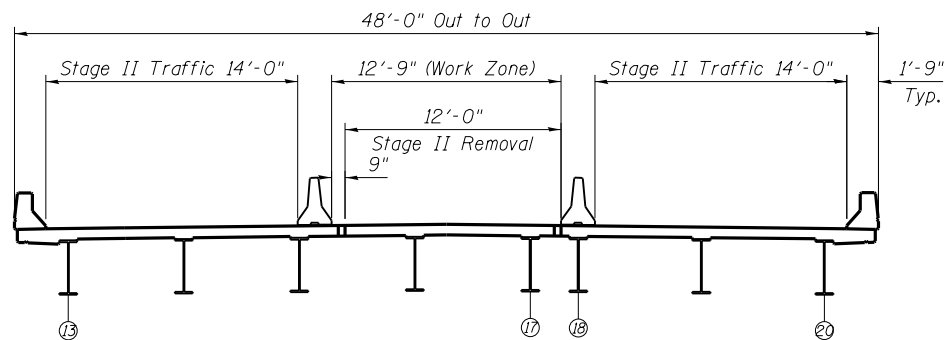

SN 082-0156 EASTBOUND CROSS SECTION
(Looking East)
STAGE II REMOVAL

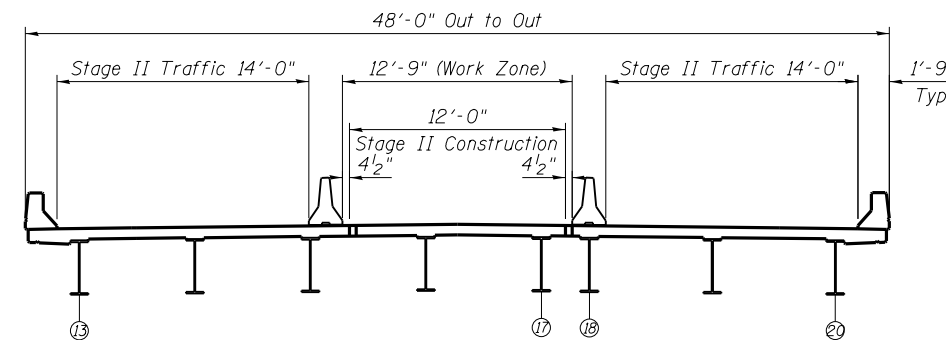

SN 082-0156 EASTBOUND CROSS SECTION
(Looking East)
STAGE II CONSTRUCTION

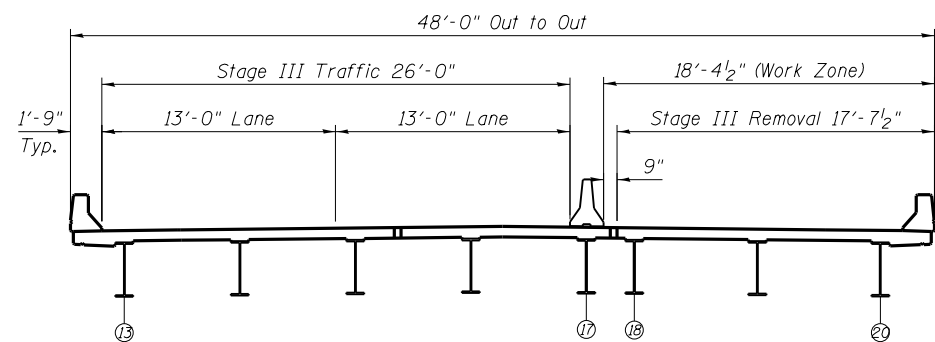

SN 082-0156 EASTBOUND CROSS SECTION
(Looking East)
STAGE III REMOVAL

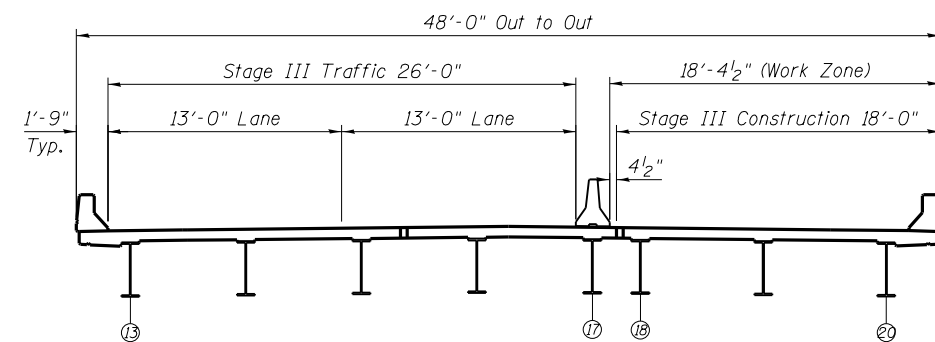

SN 082-0156 EASTBOUND CROSS SECTION
(Looking East)
STAGE III CONSTRUCTION

BENTON & ASSOCIATES, INC.

FILE NAME = P:\10e2166-2\Design\	USER NAME =	DESIGNED - MBH	REVISED -
Plans\ 082-0156 & 082-0157		CHECKED - SJH	REVISED -
0820156-76022-002-Staging.dgn	PLOT SCALE =	DRAWN - MBH	REVISED -
	PLOT DATE =	CHECKED - SJH	REVISED -

STATE OF ILLINOIS
DEPARTMENT OF TRANSPORTATION

STAGING SECTIONS
STRUCTURE NO. 082-0156

SHEET NO. 2 OF 11 SHEETS

F.A.I. RTE.	SECTION	COUNTY	TOTAL SHEETS	SHEET NO.
64	82-1VBI / 82-1VBR	ST. CLAIR	208	149
CONTRACT NO. 76022				
FED. ROAD DIST. NO. 8 ILLINOIS FED. AID PROJECT				

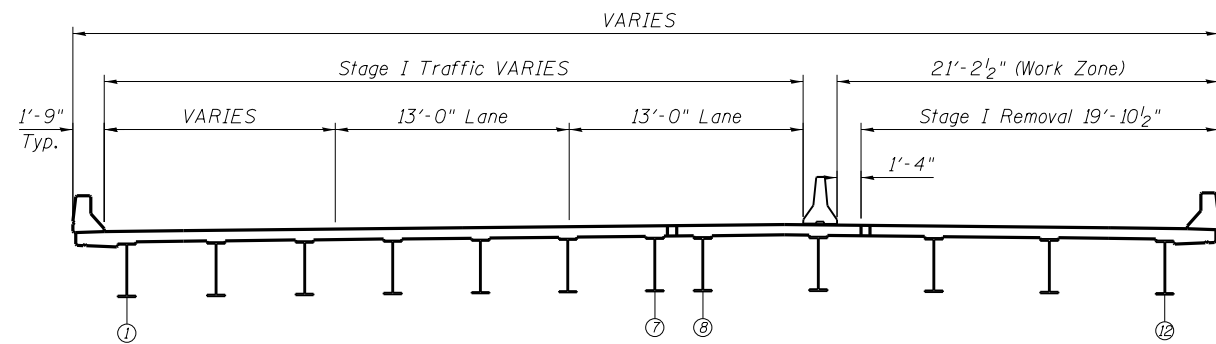

SN 082-0157 WESTBOUND CROSS SECTION
(Looking East)
STAGE I REMOVAL

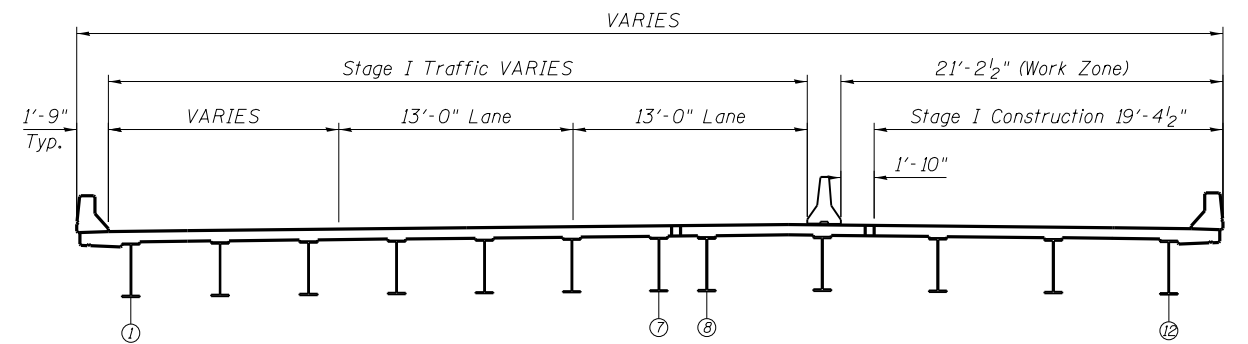

SN 082-0157 WESTBOUND CROSS SECTION
(Looking East)
STAGE I CONSTRUCTION

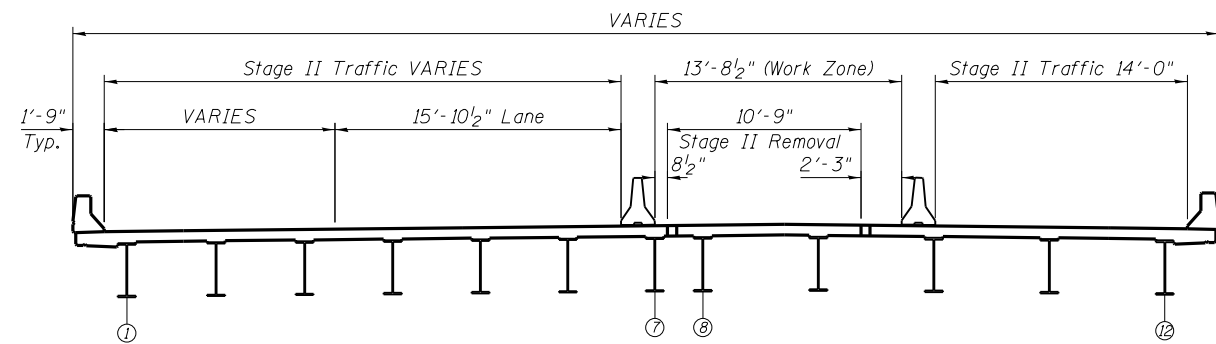

SN 082-0157 WESTBOUND CROSS SECTION
(Looking East)
STAGE II REMOVAL

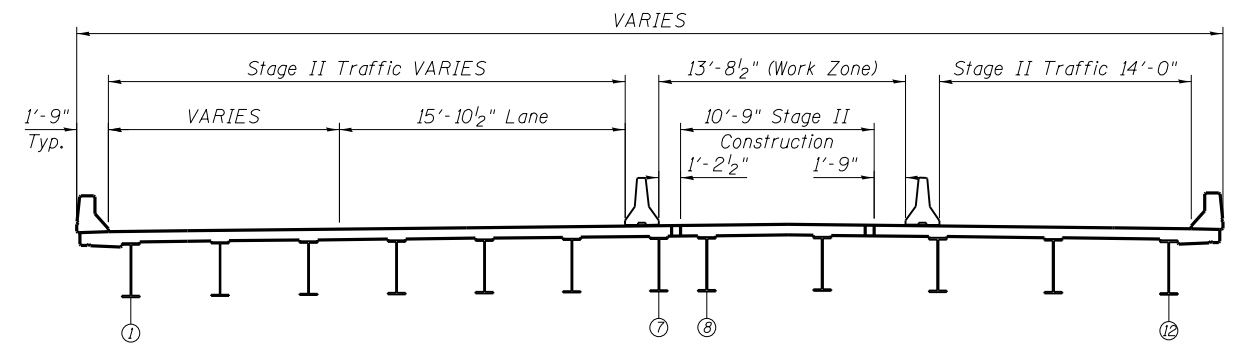

SN 082-0157 WESTBOUND CROSS SECTION
(Looking East)
STAGE II CONSTRUCTION

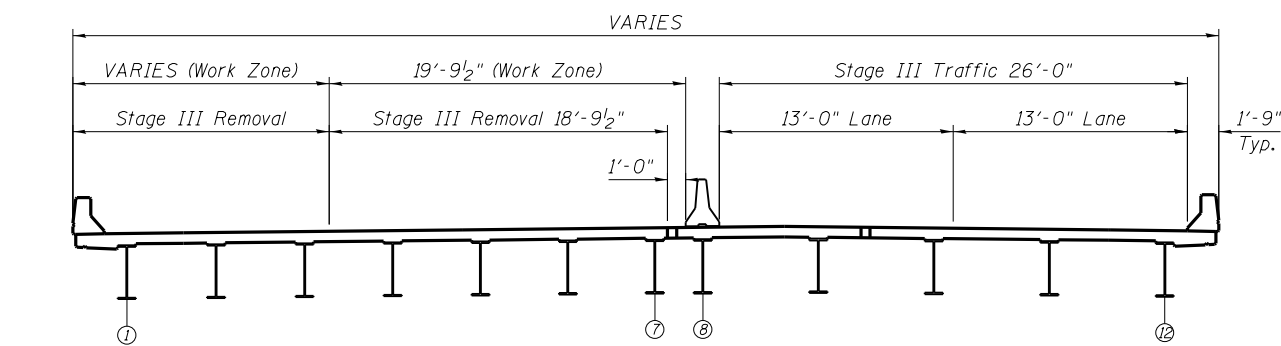

SN 082-0157 WESTBOUND CROSS SECTION
(Looking East)
STAGE III REMOVAL

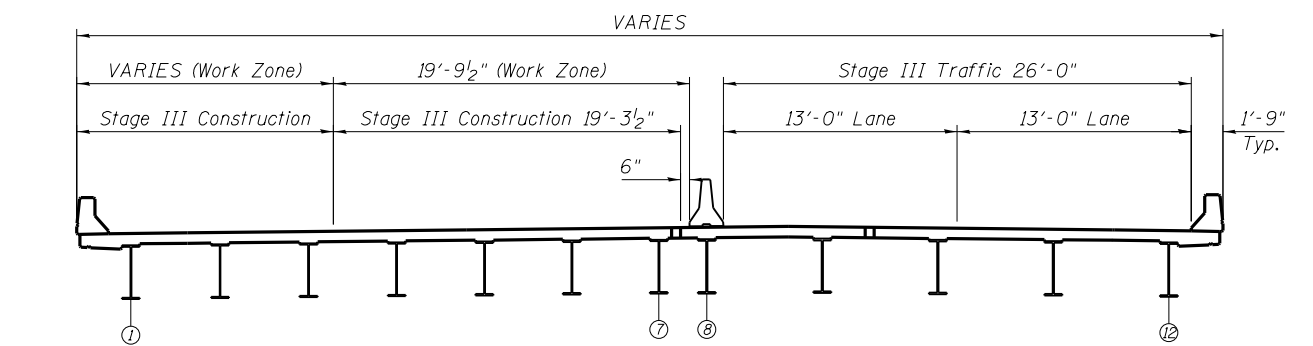

SN 082-0157 WESTBOUND CROSS SECTION
(Looking East)
STAGE III CONSTRUCTION

BENTON & ASSOCIATES, INC.

FILE NAME = P:\10e2166-2\ Design\	USER NAME =	DESIGNED - MBH	REVISED - 10/3/13
Plans\ 082-0156 & 082-0157		CHECKED - SJH	REVISED - _____
0820156-76022-002-Staging.dgn	PLOT SCALE =	DRAWN - MBH	REVISED - _____
	PLOT DATE =	CHECKED - SJH	REVISED - _____

STATE OF ILLINOIS
DEPARTMENT OF TRANSPORTATION

STAGING SECTIONS
STRUCTURE NO. 082-0157

SHEET NO. 3 OF 11 SHEETS

F.A.I. RTE.	SECTION	COUNTY	TOTAL SHEETS	SHEET NO.
64	82-1VBI / 82-1VBR	ST. CLAIR	208	150
CONTRACT NO. 76022				
FED. ROAD DIST. NO. 8 ILLINOIS FED. AID PROJECT				

When "A" is 3'-6" or less, the temporary concrete barrier shall be anchored to the new slab according to Detail I or Detail II. No anchorage is required when "A" is greater than 3'-6".

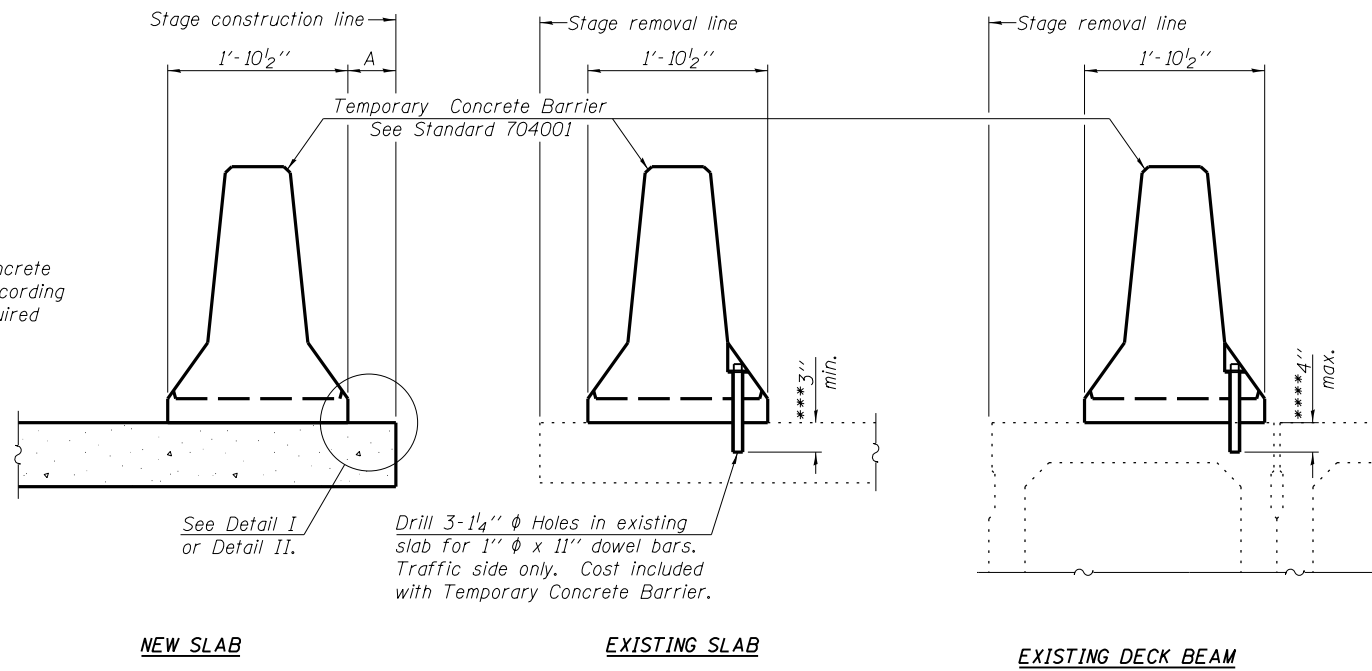

SECTIONS THRU SLAB OR DECK BEAM

NOTES

Detail I - With Bar Splicer or Couplers:
Connect one (1) 1" x 7" x "W" steel \bar{L} to the top layer of couplers with 2- $\frac{5}{8}$ " ϕ bolts screwed to coupler at approximate \bar{C} of each barrier panel.

Detail II - With Extended Reinforcement Bars:
Connect one (1) 1" x 7" x "W" steel \bar{L} to the concrete slab or concrete wearing surface with 2- $\frac{5}{8}$ " ϕ Expansion Anchors or cast in place inserts spaced between the top layer of reinforcement at approximate \bar{C} of each barrier panel.

Cost of anchorage is included with Temporary Concrete Barrier. The 1" x 7" x "W" plate shall not be removed until stage II construction forms and all reinforcement bars are in place and the concrete is ready to be placed.

*** Dimension shown is minimum required embedment into concrete. If hot-mix asphalt wearing surface is present, minimum embedment shall be in addition to wearing surface depth.

**** If existing deck beam is to remain in place after stage construction, embedment shall only be into wearing surface and not into existing deck beam concrete.

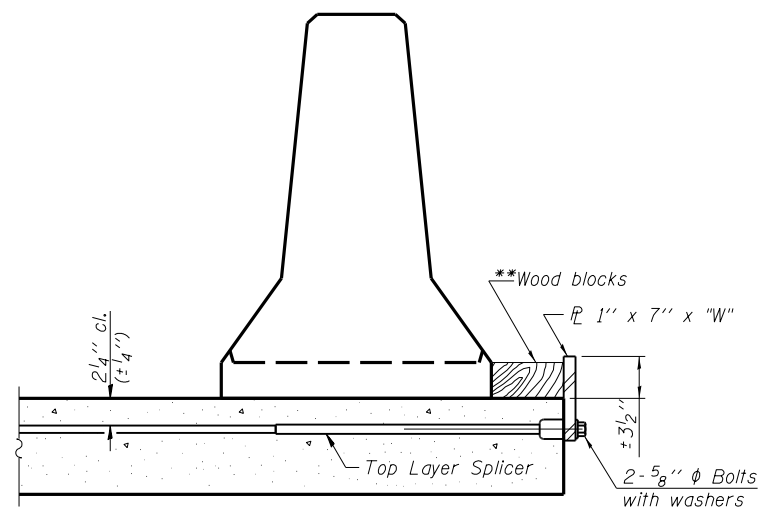

DETAIL I

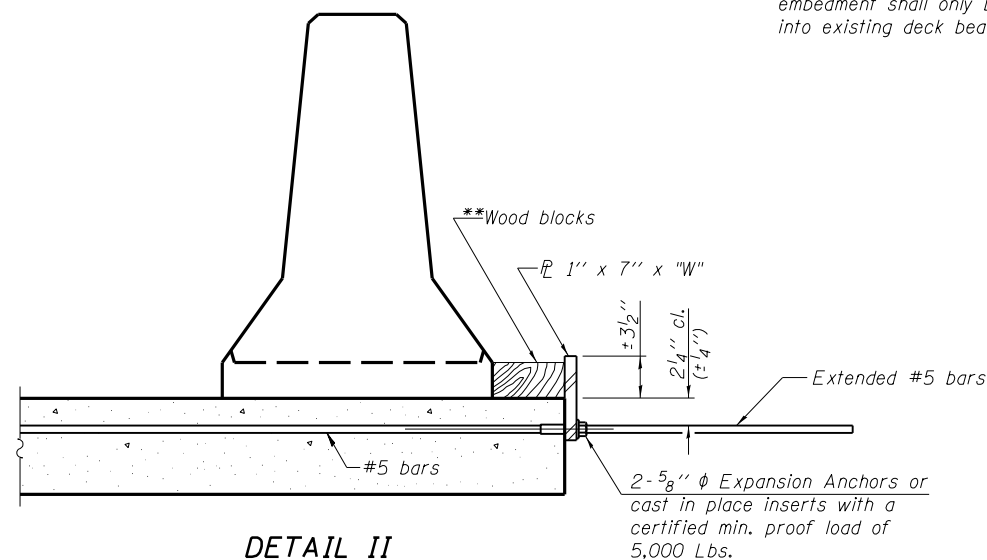

DETAIL II

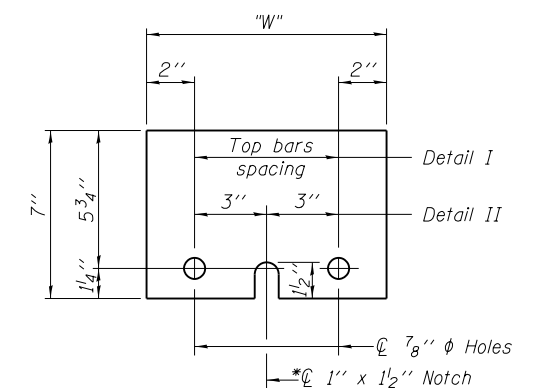

STEEL RETAINER \bar{L} 1" x 7" x "W"

* Required only with Detail II

** Wood blocks may be omitted when required to provide minimum stage traffic lane width. When the wood blocks are omitted, the concrete barrier shall be in direct contact with the steel retainer plate.

"W" = Top bars spacing + 4"

R-27 7-1-10
BENTON & ASSOCIATES, INC.

FILE NAME = P:\10e2166-2\ Design\ Plans\ 082-0156 & 082-0157	USER NAME =	DESIGNED - MBH	REVISED -
0820156-76022-003-Barrier.dgn	PLOT SCALE =	CHECKED - SJH	REVISED -
	PLOT DATE =	DRAWN - MBH	REVISED -
		CHECKED - SJH	REVISED -

STATE OF ILLINOIS
DEPARTMENT OF TRANSPORTATION

TEMPORARY CONCRETE BARRIER FOR STAGE CONSTRUCTION
STRUCTURE NO. 082-0156 & 082-0157

SHEET NO. 4 OF 11 SHEETS

F.A.I. RTE.	SECTION	COUNTY	TOTAL SHEETS	SHEET NO.
64	82-1HB1-2	ST. CLAIR	208	151
CONTRACT NO. 76022				
FED. ROAD DIST. NO. 8 ILLINOIS FED. AID PROJECT				

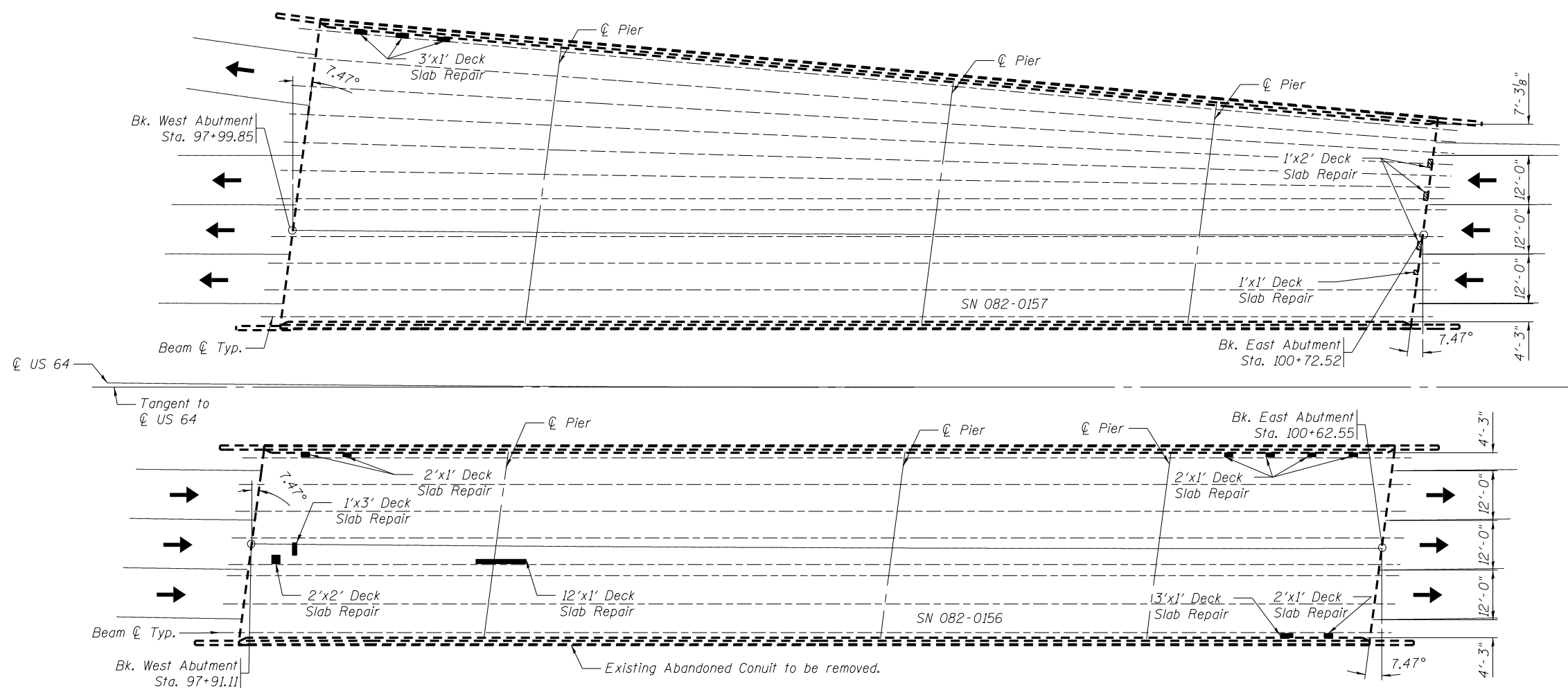

DECK REPAIR PLAN

LEGEND

- Area of Partial Depth Deck Repair
- Area of Full Depth Deck Repair

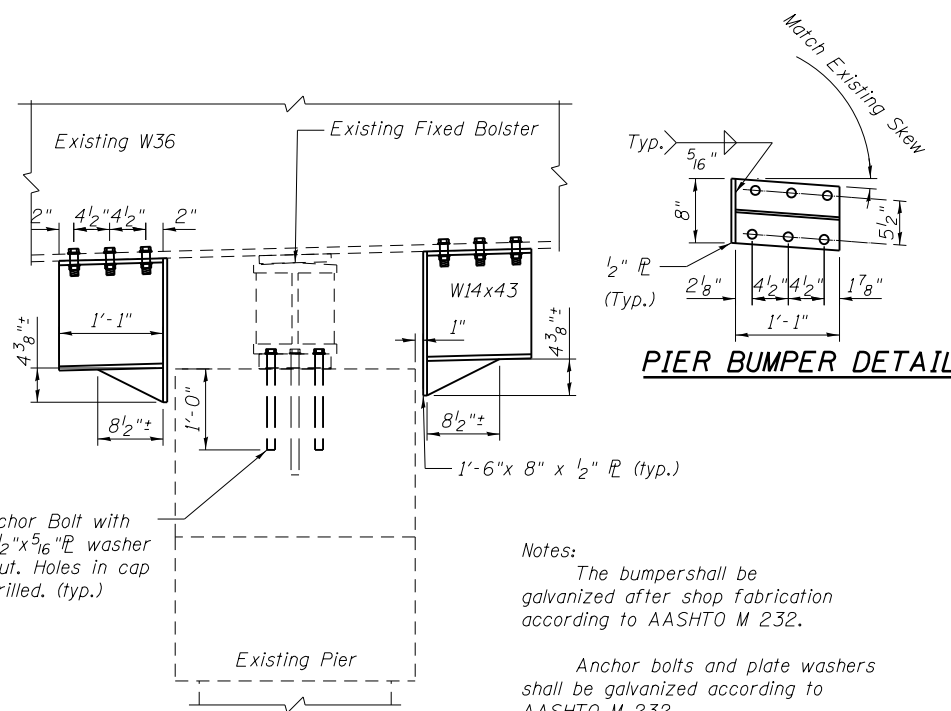

PIER BUMPER DETAIL

1" ϕ Anchor Bolt with 2 1/2" x 2 1/2" x 5/16" PL washer under nut. Holes in cap to be drilled. (typ.)

Notes:
The bumpers shall be galvanized after shop fabrication according to AASHTO M 232.
Anchor bolts and plate washers shall be galvanized according to AASHTO M 232.

NEW PIER BUMBERS
(At Existing Fixed Bearing Bolster on Center Pier on both structures)

BILL OF MATERIAL

ITEM	UNIT	QUANTITY
Deck Slab Repair (Full)	Sq. Yd.	5.0
Deck Slab Repair (Partial)	Sq. Yd.	0.8
Furnishing and Erecting Structural Steel	Pound	7270
Remove Existing Conduit Attached to Structure	Foot	272
Anchor Bolts, 1"	Each	80

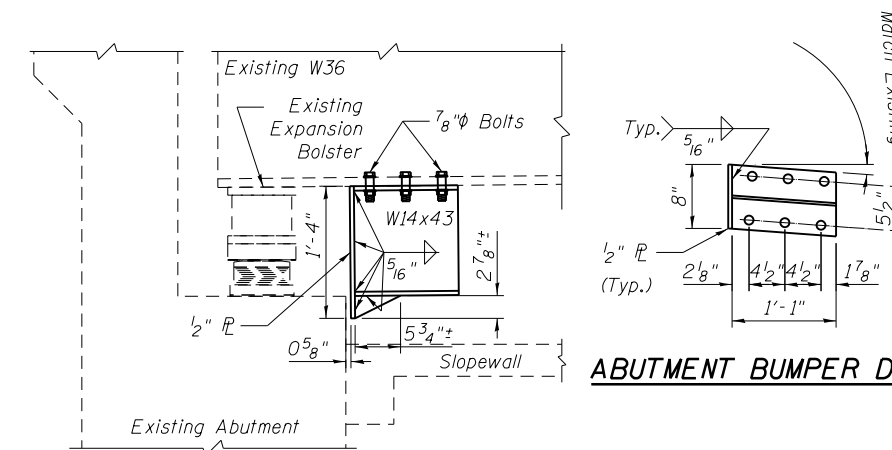

ABUTMENT BUMPER DETAIL

NEW ABUTMENT BUMPER
(At Existing Expansion Bearing Bolster on Abutments on both structures)

BENTON & ASSOCIATES, INC.

FILE NAME = P:\10e2166-2\Design\	USER NAME =	DESIGNED - MBH	REVISED - 10/3/13
Plans\082-0156 & 082-0157		CHECKED - SJH	REVISED -
0820156-76022-004-Deck.dgn	PLOT SCALE =	DRAWN - MBH	REVISED -
	PLOT DATE =	CHECKED - SJH	REVISED -

**STATE OF ILLINOIS
DEPARTMENT OF TRANSPORTATION**

**DECK REPAIRS
STRUCTURE NO. 082-0156 & 082-0157**

SHEET NO. 5 OF 11 SHEETS

F.A.I. RTE.	SECTION	COUNTY	TOTAL SHEETS	SHEET NO.
64	82-1VBI / 82-1VBR	ST. CLAIR	208	152
CONTRACT NO. 76022				
FED. ROAD DIST. NO. 8 ILLINOIS FED. AID PROJECT				

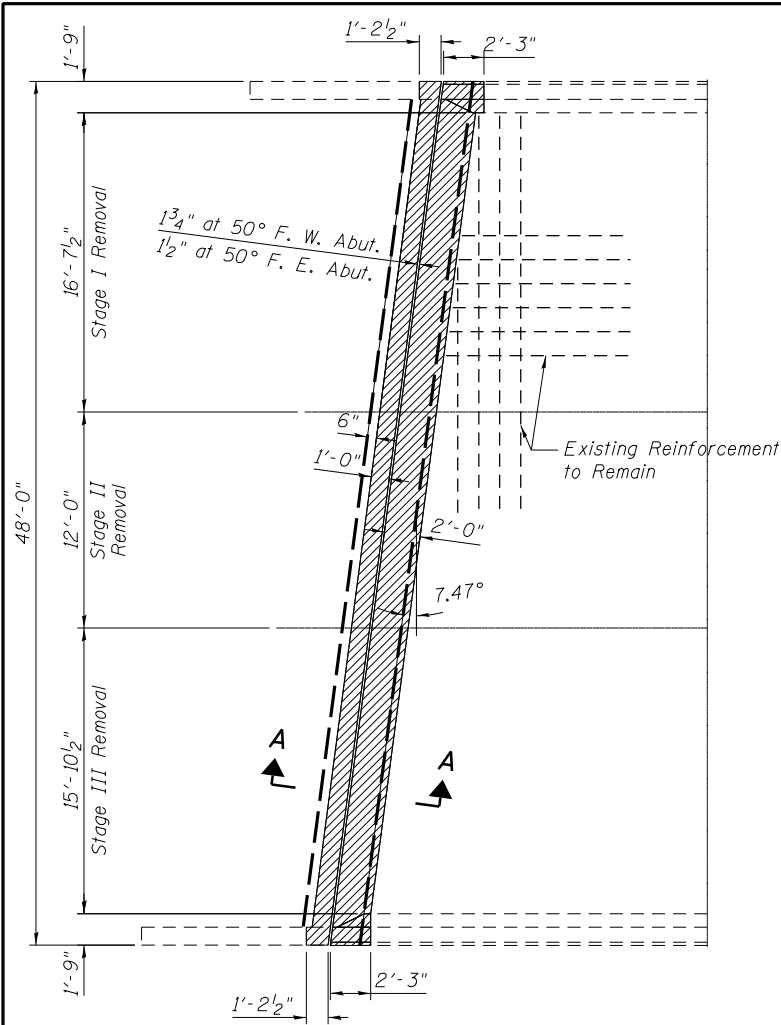

CONCRETE REMOVAL

(West Abut. shown)
(East Abut. similar)

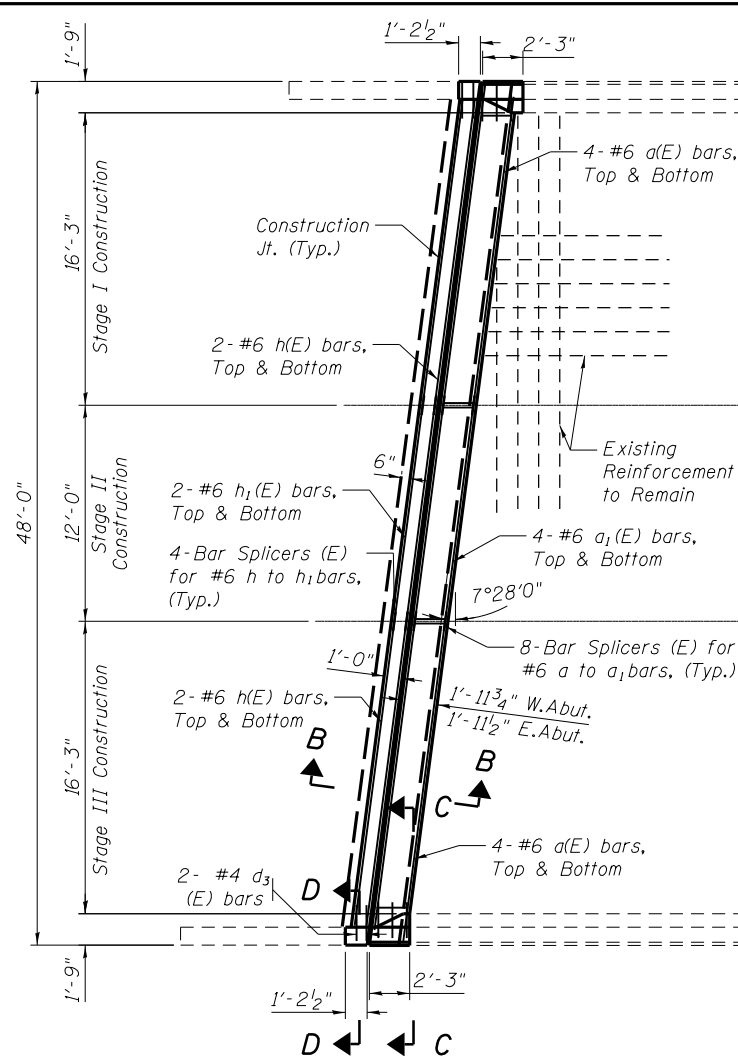

CONCRETE REPLACEMENT

(West Abut. shown)
(East Abut. similar)

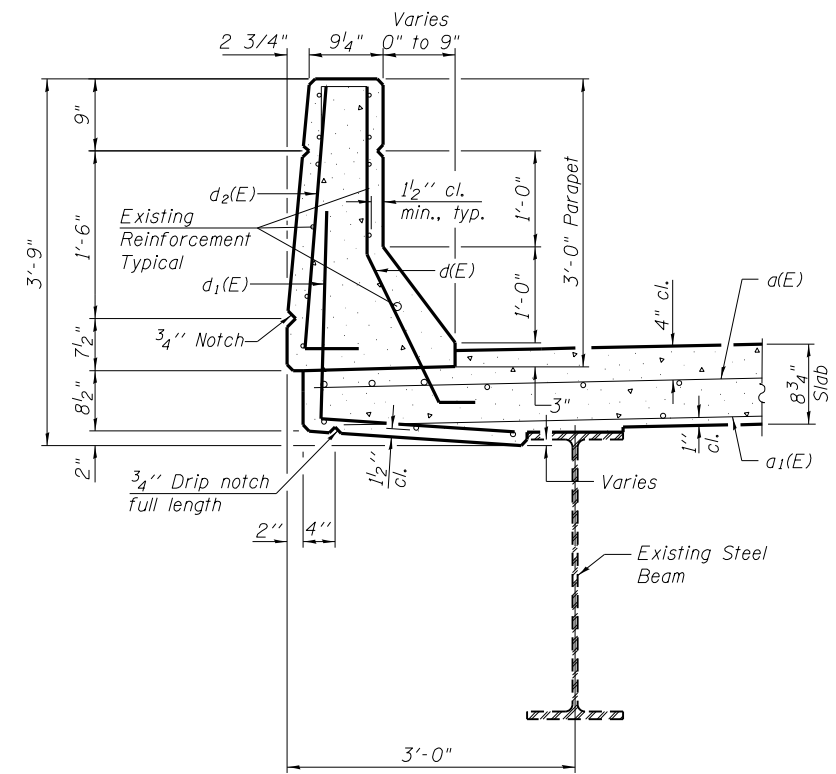

SECTION C-C

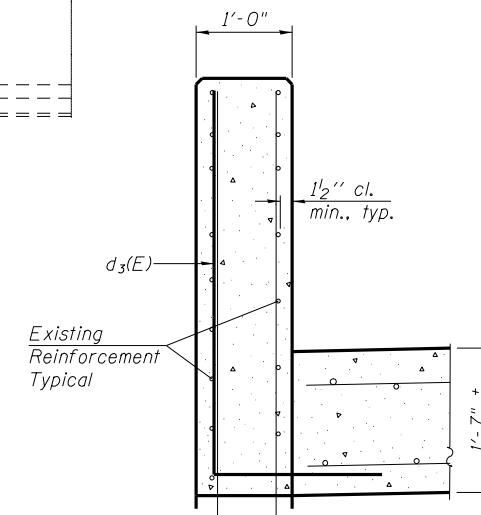

SECTION D-D

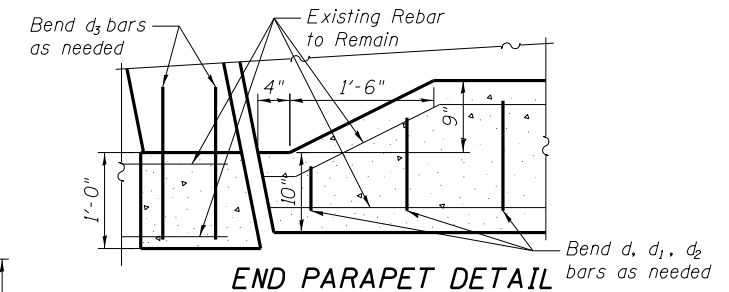

END PARAPET DETAIL

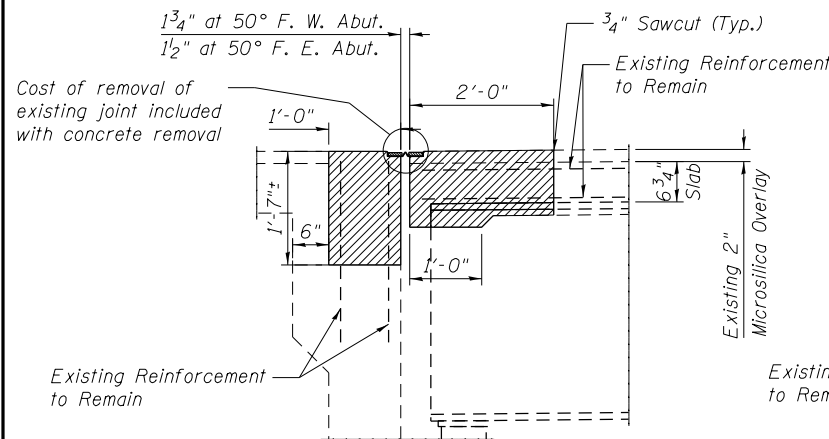

SECTION A-A

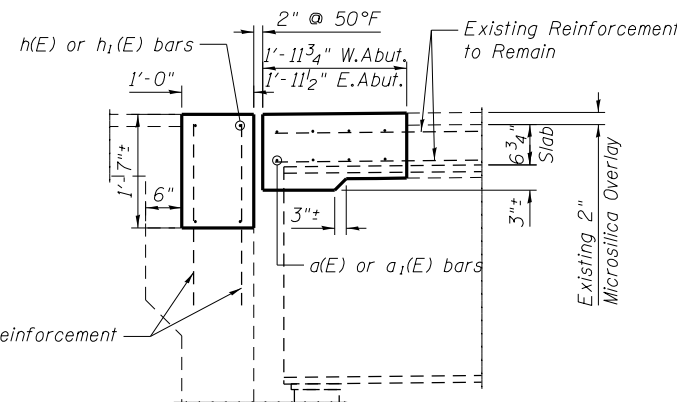

SECTION B-B

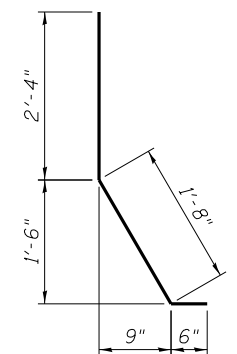

BAR d(E)

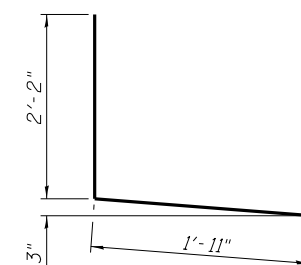

BAR d1(E)

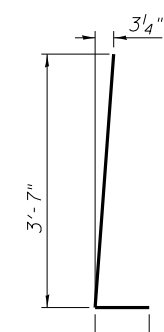

BAR d2(E)

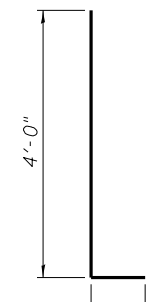

BAR d3(E)

**SUPERSTRUCTURE
BILL OF MATERIAL**

Bar	No.	Size	Length	Shape
a(E)	32	#6	17'-9"	—
a1(E)	16	#6	12'-0"	—
d(E)	12	#5	4'-6"	L
d1(E)	12	#4	4'-1"	L
d2(E)	12	#4	4'-4"	L
d3(E)	8	#4	5'-9"	L
h(E)	16	#6	17'-2"	—
h1(E)	8	#6	12'-0"	—
Bar Splicers			Each	48
Reinforcement Bars, Epoxy Coated			Pound	1860
Concrete Superstructure			Cu. Yds.	12.9
Concrete Removal			Cu. Yds.	13.0
Preformed Strip Seal			Foot	97

FILE NAME = P:\10e2166-2\ Design\	USER NAME =	DESIGNED - MBH	REVISED - 10/3/13
Plans\ 082-0156 & 082-0157		CHECKED - SJH	REVISED -
0820156-76022-005-Joint.dgn	PLOT SCALE =	DRAWN - MBH	REVISED -
	PLOT DATE =	CHECKED - SJH	REVISED -

STATE OF ILLINOIS
DEPARTMENT OF TRANSPORTATION

CONCRETE REMOVAL & REPLACEMENT
STRUCTURE NO. 082-0156

SHEET NO. 6 OF 11 SHEETS

F.A.I. RT.	SECTION	COUNTY	TOTAL SHEETS	SHEET NO.
64	82-1VBI / 82-1VBR	ST. CLAIR	208	153
CONTRACT NO. 76022				
FED. ROAD DIST. NO. 8 ILLINOIS FED. AID PROJECT				

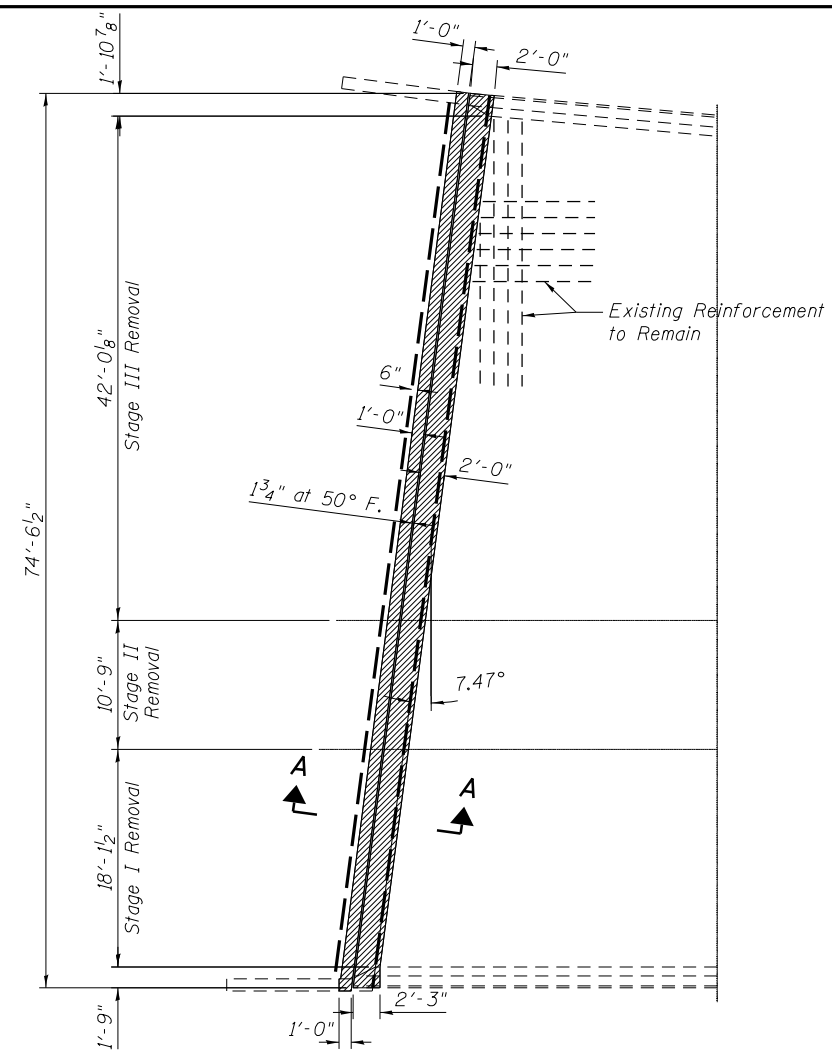

CONCRETE REMOVAL
(West Abut. shown)

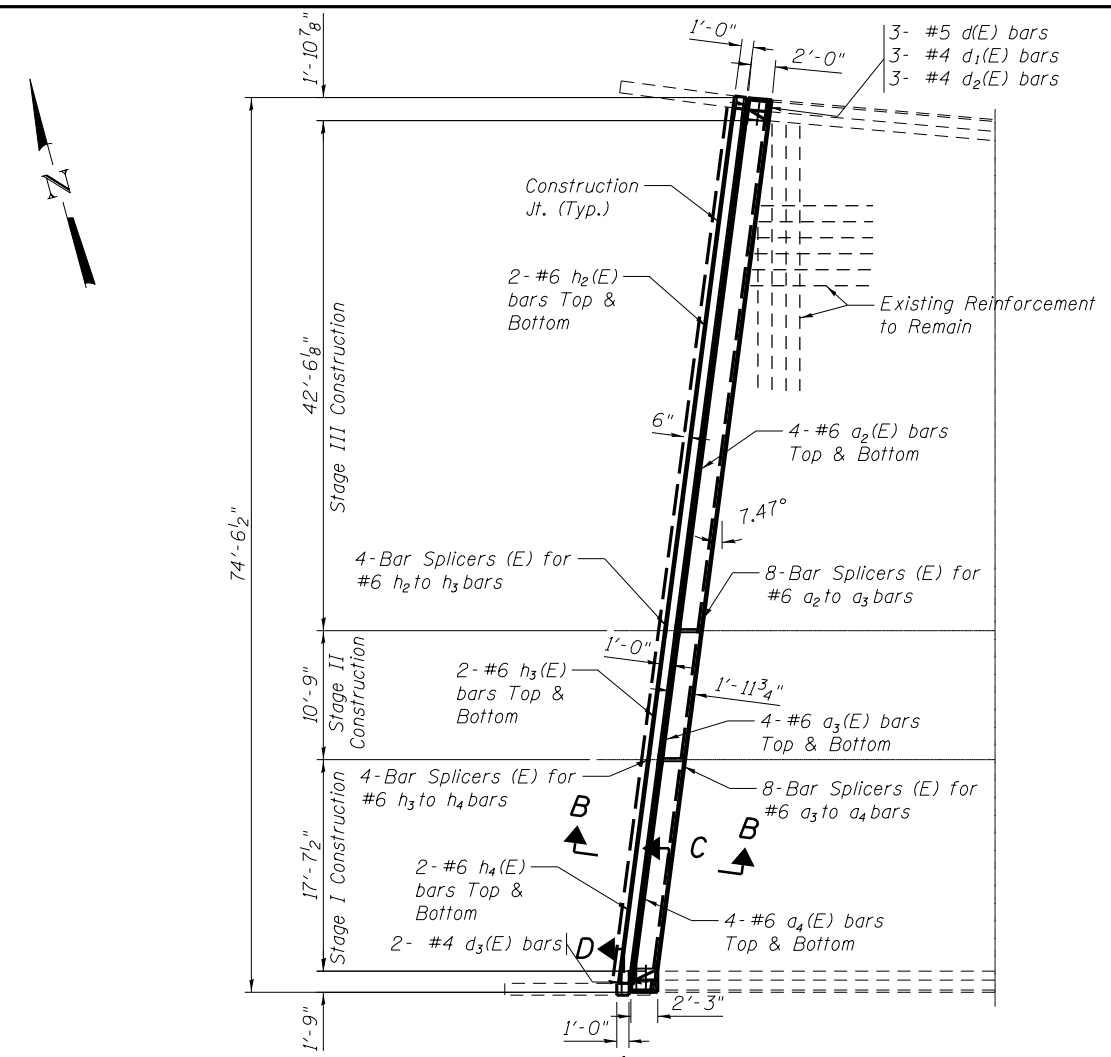

CONCRETE REPLACEMENT
(West Abut. shown)

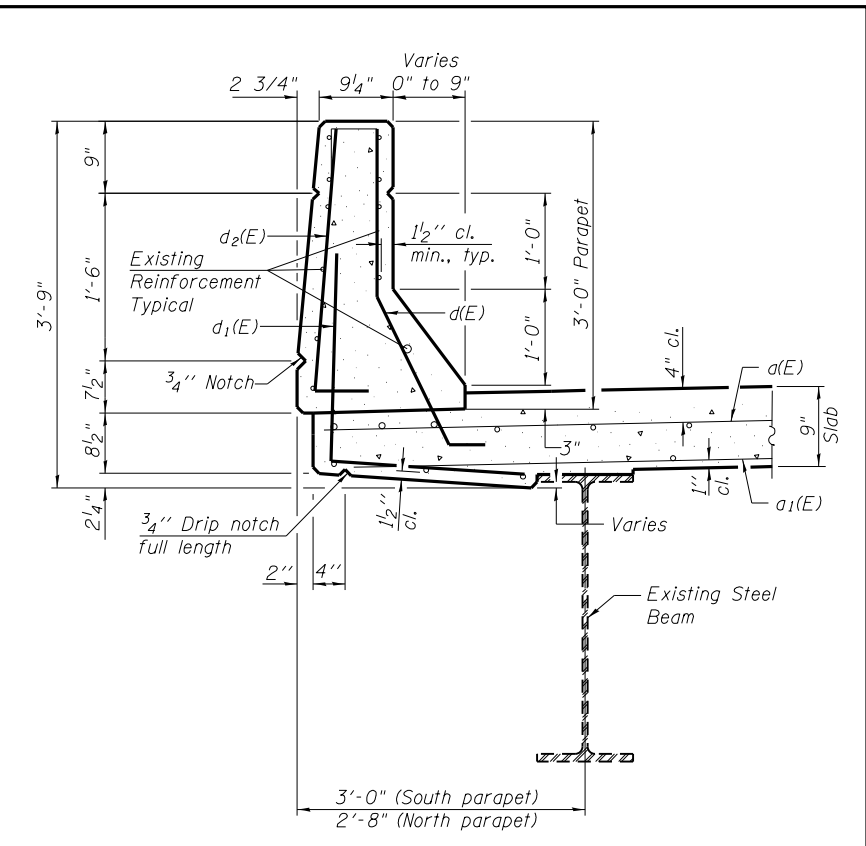

SECTION C-C

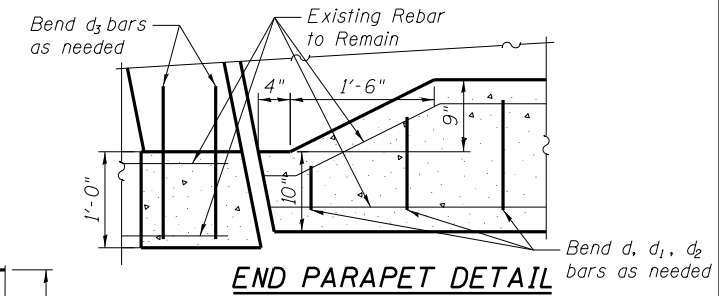

END PARAPET DETAIL

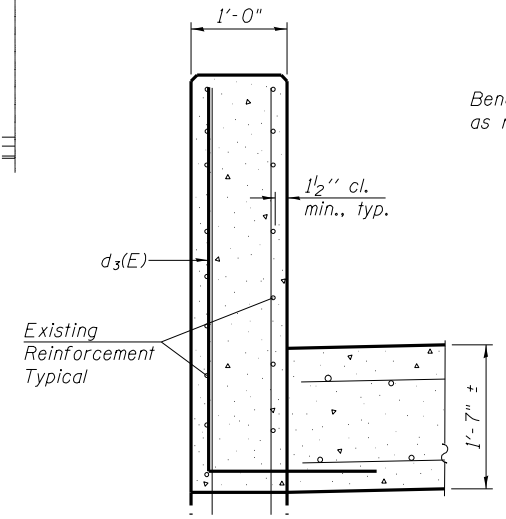

SECTION D-D

**SUPERSTRUCTURE
BILL OF MATERIAL**

Bar	No.	Size	Length	Shape
a ₂ (E)	8	#6	44'-5"	—
a ₃ (E)	8	#6	10'-7"	—
a ₄ (E)	8	#6	19'-1"	—
d(E)	6	#5	4'-6"	┌
d ₁ (E)	6	#4	4'-1"	┌
d ₂ (E)	6	#4	4'-4"	┌
d ₃ (E)	4	#4	5'-9"	┌
h ₂ (E)	4	#6	43'-7"	—
h ₃ (E)	4	#6	11'-4"	—
h ₄ (E)	4	#6	19'-5"	—
Bar Splicers			Each	24
Reinforcement Bars, Epoxy Coated			Pound	1420
Concrete Superstructure			Cu. Yds.	9.9
Concrete Removal			Cu. Yds.	10.0
Performed Strip Seal			Foot	75

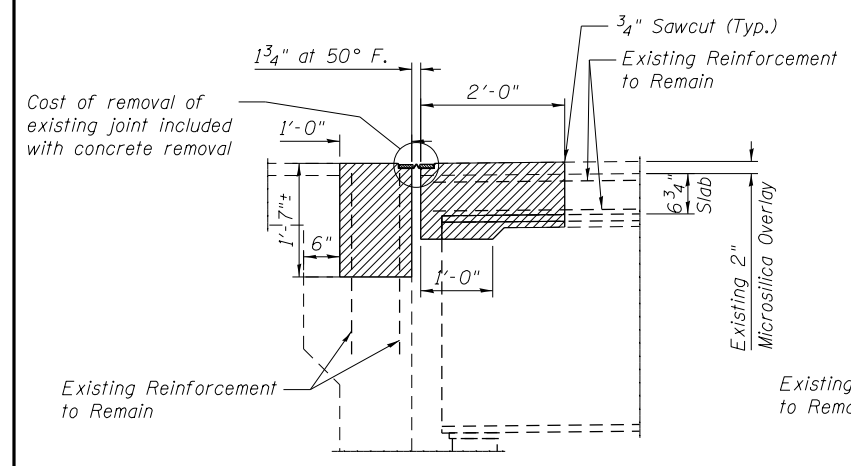

SECTION A-A

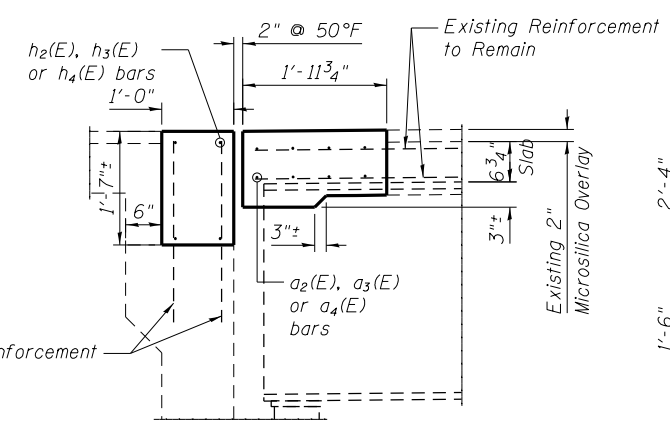

SECTION B-B

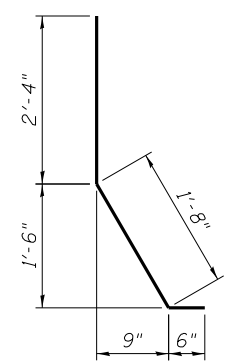

BAR d(E)

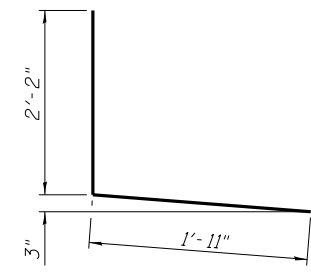

BAR d1(E)

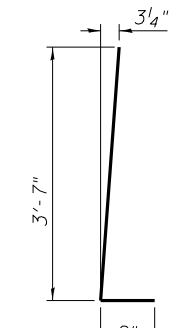

BAR d2(E)

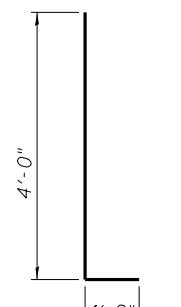

BAR d3(E)

FILE NAME = P:\10e2166-2\ Design\ Plans\ 082-0156 & 082-0157	USER NAME =	DESIGNED - MBH	REVISED - 10/3/13
0820156-76022-006-Joint.dgn	PLOT SCALE =	CHECKED - SJH	REVISED -
	PLOT DATE =	DRAWN - MBH	REVISED -
		CHECKED - SJH	REVISED -

**STATE OF ILLINOIS
DEPARTMENT OF TRANSPORTATION**

**CONCRETE REMOVAL & REPLACEMENT
STRUCTURE NO. 082-0157**

SHEET NO. 7 OF 11 SHEETS

F.A.I. RTE.	SECTION	COUNTY	TOTAL SHEETS	SHEET NO.
64	82-1VBI / 82-1VBR	ST. CLAIR	208	154
CONTRACT NO. 76022				
FED. ROAD DIST. NO. 8 ILLINOIS FED. AID PROJECT				

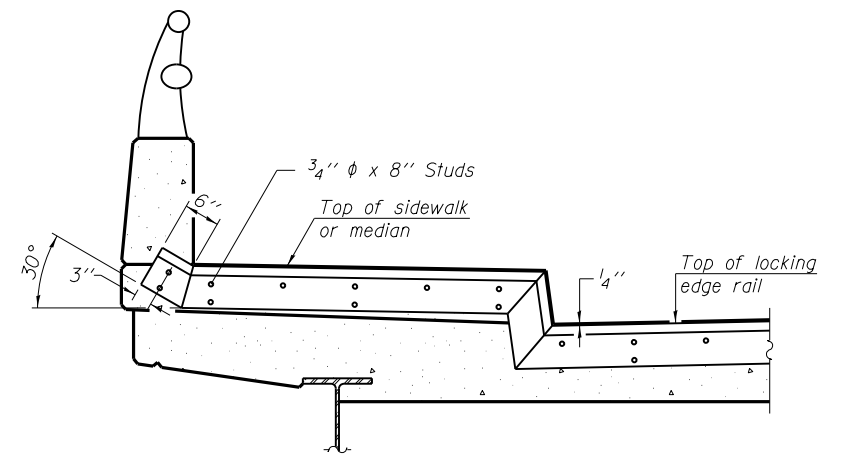
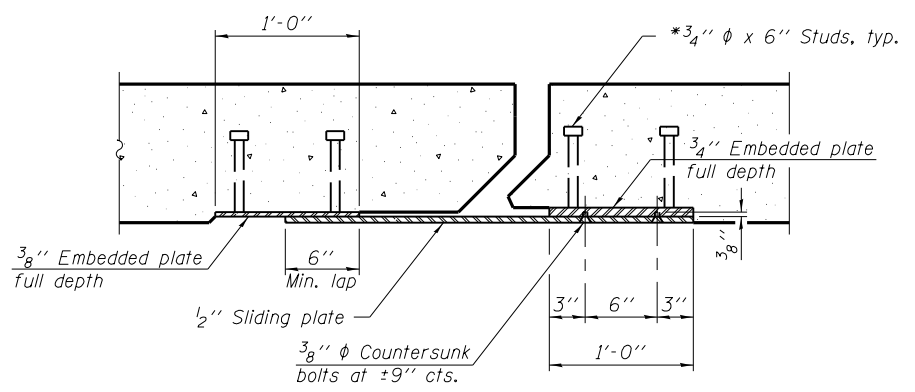
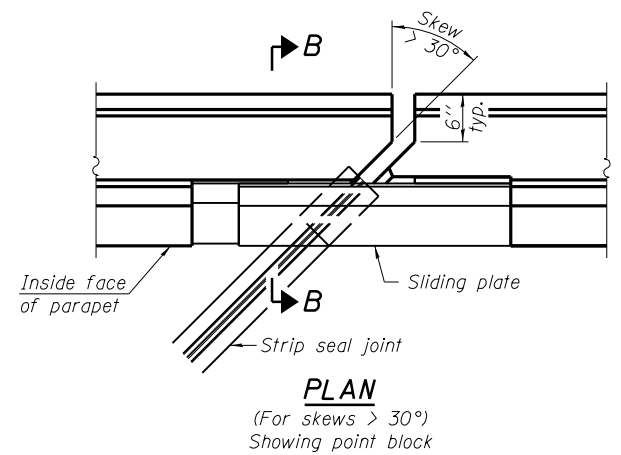
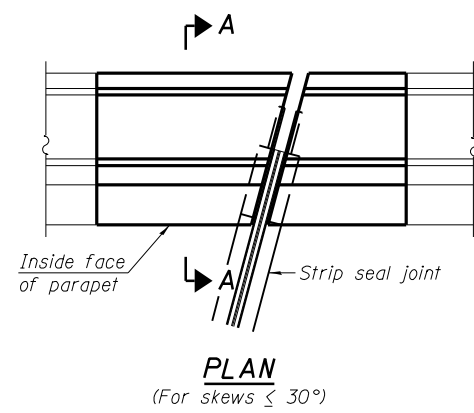

TYPICAL END TREATMENT AT SIDEWALK OR MEDIAN
 Shorter plates with a single row of studs at 12" cts. may be necessary on medians which are shallower than 9". See manufacturer's recommendation.

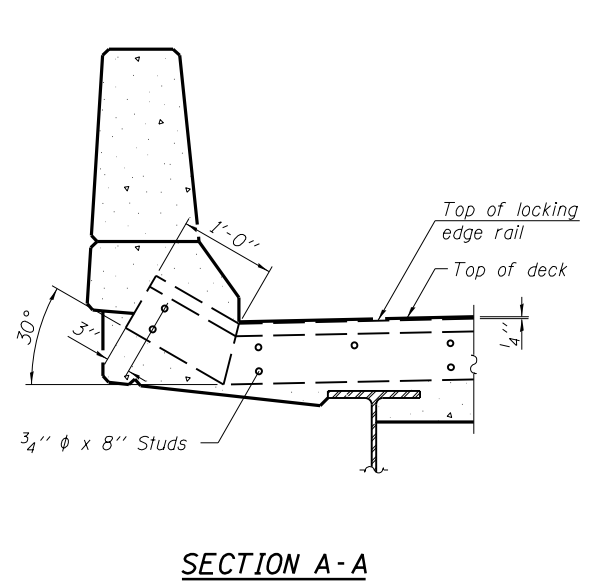

SECTION A-A

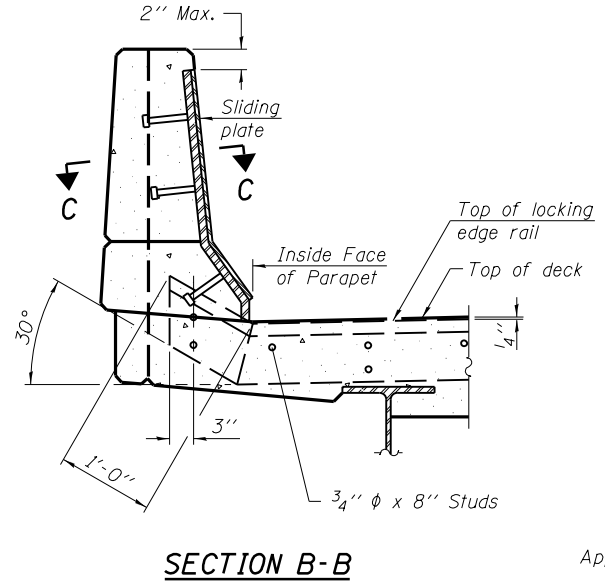

SECTION B-B

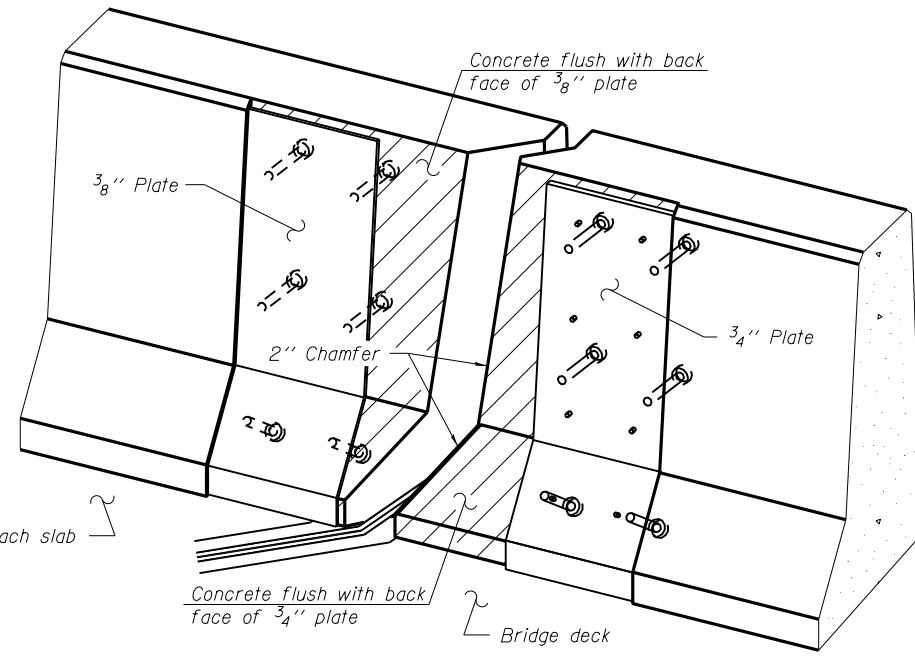

TRIMETRIC VIEW (Showing back plates only)

Notes:
 The strip seal shall be made continuous and shall have a minimum thickness of 1/4". The configuration of the strip seal shall match the configuration of the Locking Edge Rails. Open or "webbed" strip seal gland configurations are not permitted. The gland shall be sized for a maximum rated movement of 4 inches.
 The Locking Edge Rails depicted are conceptual only, except for the minimum dimensions shown. The actual configuration of the Locking Edge Rails and matching strip seal may vary from manufacturer to manufacturer. Flanged edge rails will not be allowed. Locking Edge Rails may be spliced at slope discontinuities.
 The manufacturer's recommended installation methods shall be followed.
 The joint opening and deck dimensions detailed on the superstructure are based on a rolled rail expansion joint. If the Contractor elects to use the welded rail expansion joint, the opening and deck dimensions shall be modified according to the dimensions detailed on this sheet. Required modifications shall be made at no additional cost to the State.
 All steel components shall be galvanized after fabrication according to Article 520.03 of the Standard Specifications.
 Maximum space between rail segments at stage lines shall be 3/16", sealed with a suitable sealant.
 Parapet plates and anchorage studs for skews > 30 degrees included in the cost of Preformed Joint Strip Seal.

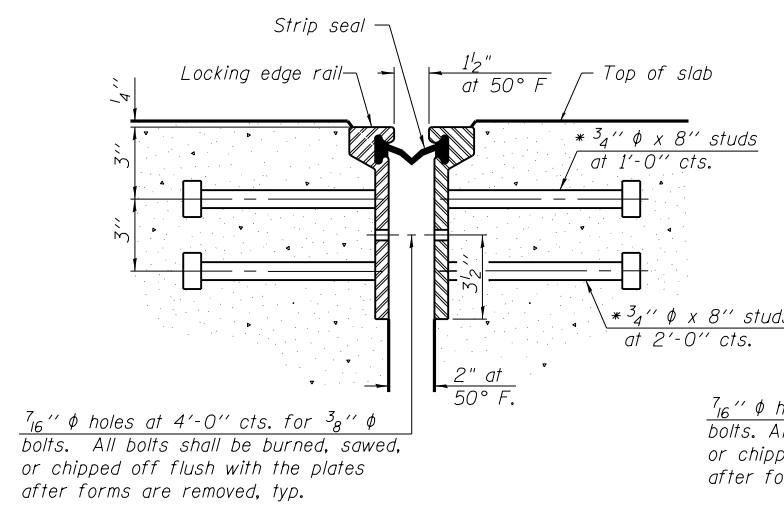

SECTION THRU ROLLED RAIL JOINT

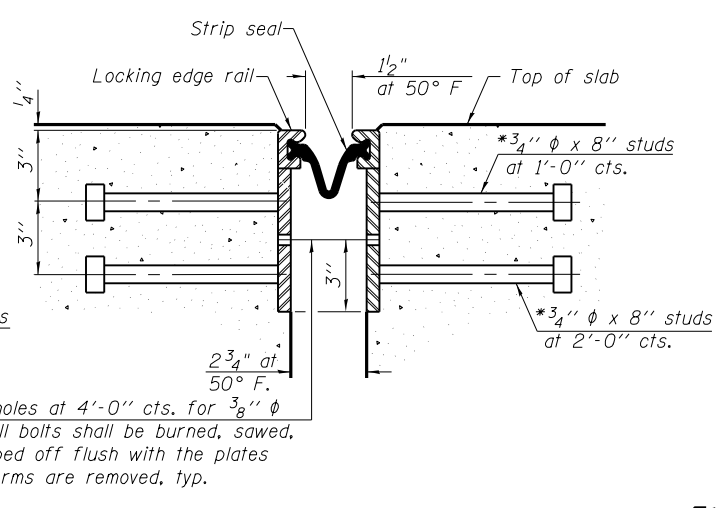

SECTION THRU WELDED RAIL JOINT

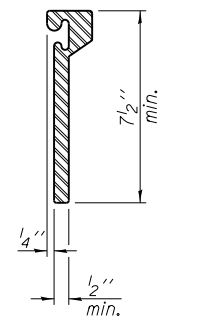

ROLLED EXTRUDED RAIL

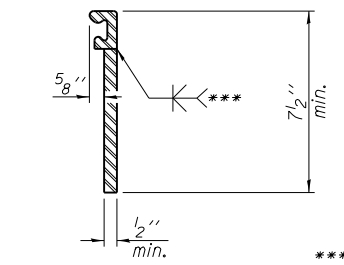

WELDED RAIL

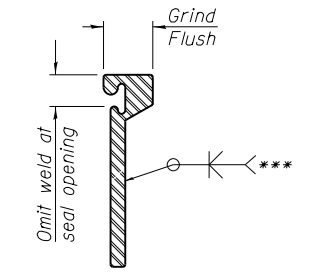

LOCKING EDGE RAIL SPLICE

The inside of the locking edge rail groove shall be free of weld residue.
 Rolled rail shown, welded rail similar.

LOCKING EDGE RAILS

BILL OF MATERIAL

Item	Unit	Total
Preformed Joint Strip Seal	Foot	224

EJ-SSJ 7-1-10
BENTON & ASSOCIATES, INC.

* Granular or solid flux filled headed studs conforming to Article 1006.32 of the Std. Specs., automatically end welded.

FILE NAME = P:\10e2166-2\ Design\ Plans\ 082-0156 & 082-0157	USER NAME =	DESIGNED - MBH	REVISED -
0820156-76022-008-Joint.dgn	PLOT SCALE =	CHECKED - SJH	REVISED -
	PLOT DATE	DRAWN - MBH	REVISED -
		CHECKED - SJH	REVISED -

STATE OF ILLINOIS
DEPARTMENT OF TRANSPORTATION

PREFORMED JOINT STRIP SEAL
STRUCTURE NO. 082-0156 & 082-0157

SHEET NO. 9 OF 11 SHEETS

F.A.I. RTE.	SECTION	COUNTY	TOTAL SHEETS	SHEET NO.
64	82-1VBI / 82-1VBR	ST. CLAIR	208	156
CONTRACT NO. 76022				
FED. ROAD DIST. NO. 8 ILLINOIS FED. AID PROJECT				

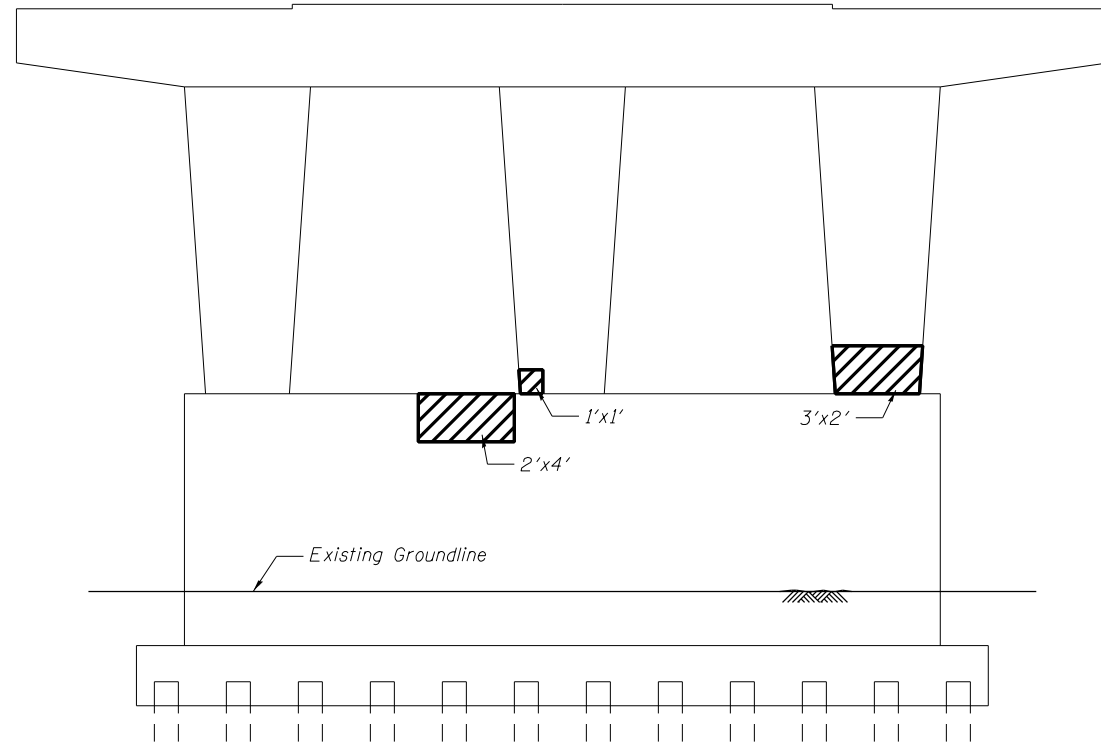

STRUCTURE 082-0156 CENTER PIER
(Looking West)

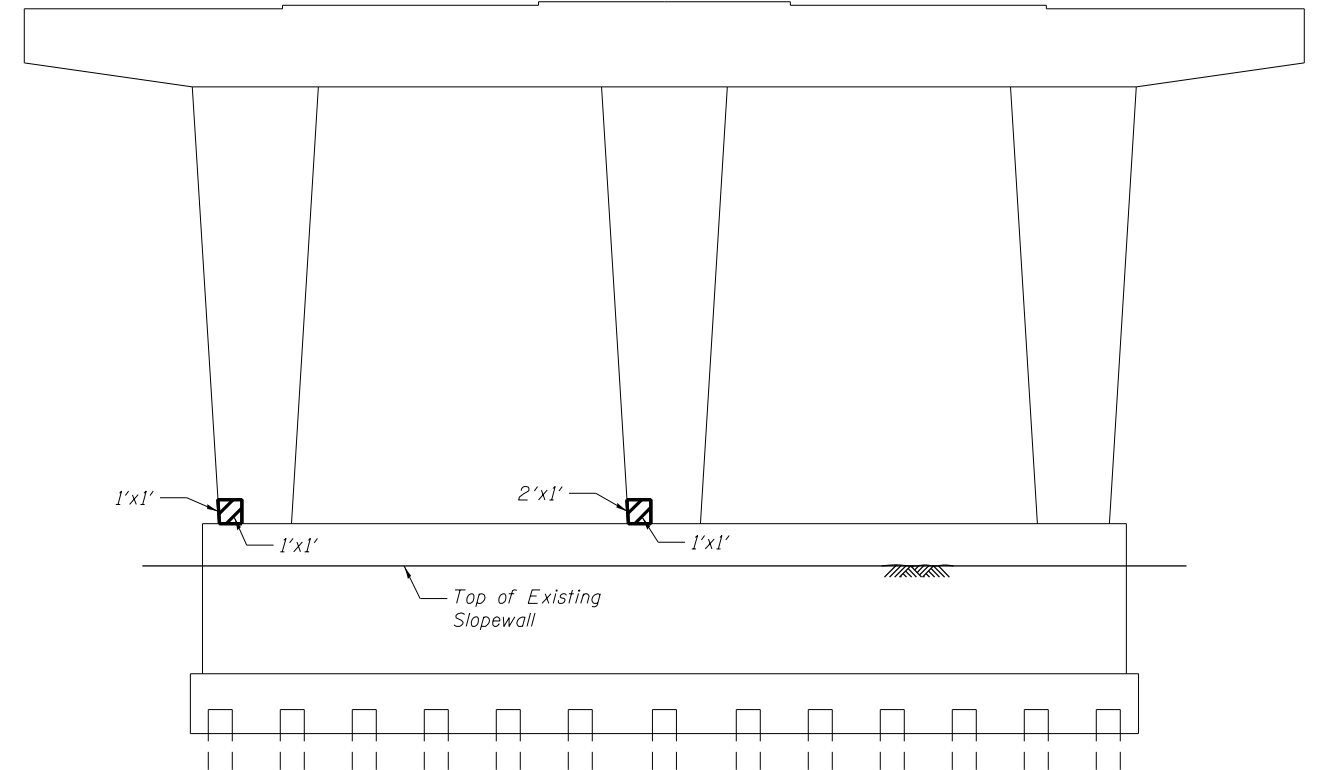

STRUCTURE 082-0157 EAST PIER
(Looking East)

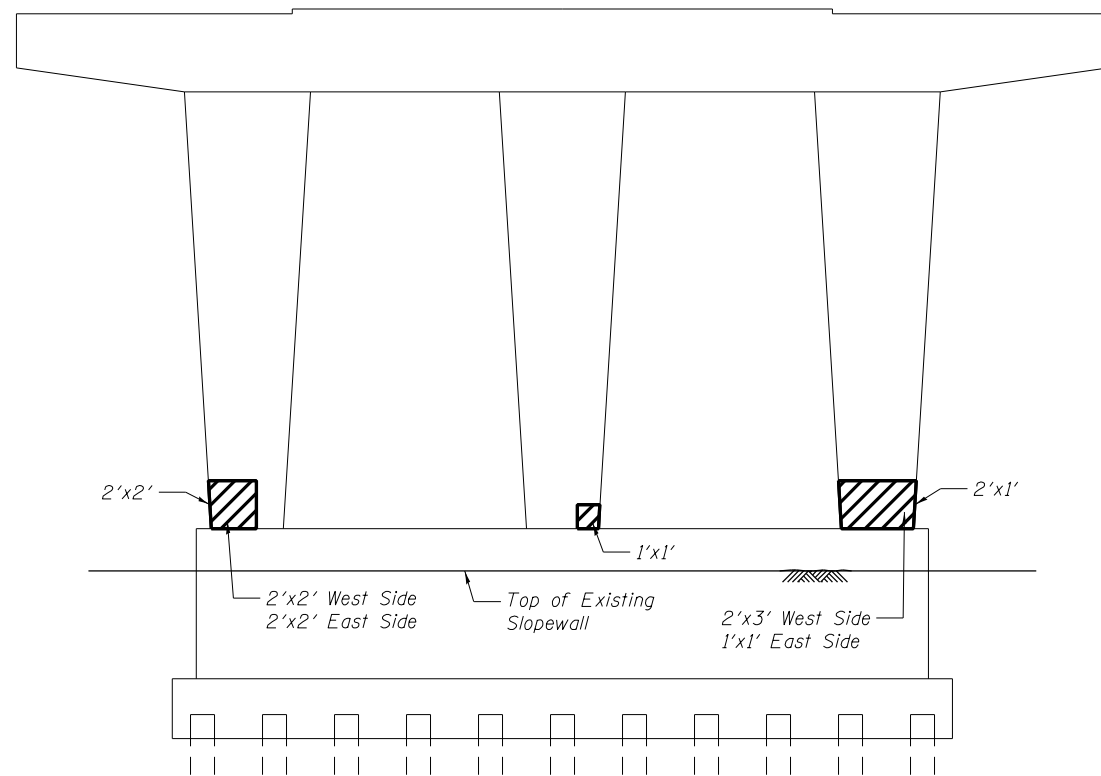

STRUCTURE 082-0156 EAST PIER
(Looking East)

LEGEND

▨ Area of Structural Concrete Repair

BILL OF MATERIAL

Item	Unit	Total
Structural Repair of Concrete (Depth <= 5")	Sq. Ft.	42

BENTON & ASSOCIATES, INC.

FILE NAME = P:\10e2166-2\ Design\ Plans\ 082-0156 & 082-0157 0820156-76022-009-Piers.dgn	USER NAME =	DESIGNED - MBH	REVISED -
		CHECKED - SJH	REVISED -
	PLOT SCALE =	DRAWN - MBH	REVISED -
	PLOT DATE =	CHECKED - SJH	REVISED -

**STATE OF ILLINOIS
DEPARTMENT OF TRANSPORTATION**

**SUBSTRUCTURE REPAIRS
STRUCTURE NO. 082-0156 & 082-0157**

SHEET NO. 10 OF 11 SHEETS

F.A.I. RTE.	SECTION	COUNTY	TOTAL SHEETS	SHEET NO.
64	82-1VBI / 82-1VBR	ST. CLAIR	208	157
CONTRACT NO. 76022				
FED. ROAD DIST. NO. 8 ILLINOIS FED. AID PROJECT				

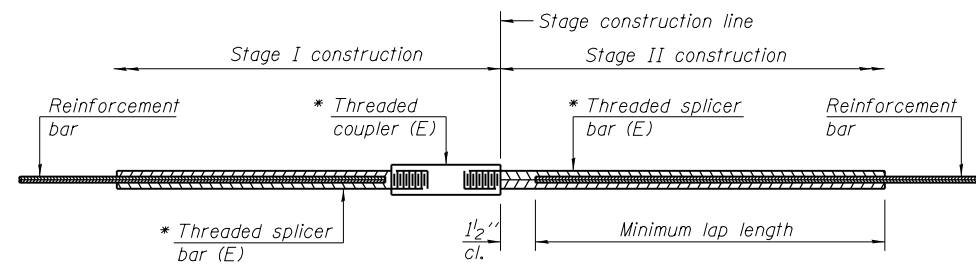

STANDARD BAR SPLICER ASSEMBLY

Minimum Lap Lengths					
Bar size to be spliced	Table 1	Table 2	Table 3	Table 4	Table 5
3, 4	1'-5"	1'-11"	2'-1"	2'-4"	2'-3"
5	1'-9"	2'-5"	2'-7"	2'-11"	2'-10"
6	2'-1"	2'-11"	3'-1"	3'-6"	3'-4"
7	2'-9"	3'-10"	4'-2"	4'-8"	4'-6"
8	3'-8"	5'-1"	5'-5"	6'-2"	5'-10"
9	4'-7"	6'-5"	6'-10"	7'-9"	7'-5"

- Table 1: Black bar, 0.8 Class C
- Table 2: Black bar, Top bar lap, 0.8 Class C
- Table 3: Epoxy bar, 0.8 Class C
- Table 4: Epoxy bar, Top bar lap, 0.8 Class C
- Table 5: Epoxy bar, Top bar lap, Class B

Threaded splicer bar length = min. lap length + 1/2" + thread length

* Epoxy not required on Bar Splicer Assembly components used in conjunction with black bars.

Location	Bar size	No. assemblies required	Table for minimum lap length
SN 082-0156 Deck	#6	32	Table 3
SN 082-0156 Hatch	#6	16	Table 3
SN 082-0157 Deck	#6	8	Table 3
SN 082-0157 Deck	#6	8	Table 3
SN 082-0157 Deck	#6	8	Table 3
SN 082-0157 Deck	#6	8	Table 3
SN 082-0157 Hatch	#6	4	Table 3
SN 082-0157 Hatch	#6	4	Table 3
SN 082-0157 Hatch	#6	4	Table 3
SN 082-0157 Hatch	#6	4	Table 3

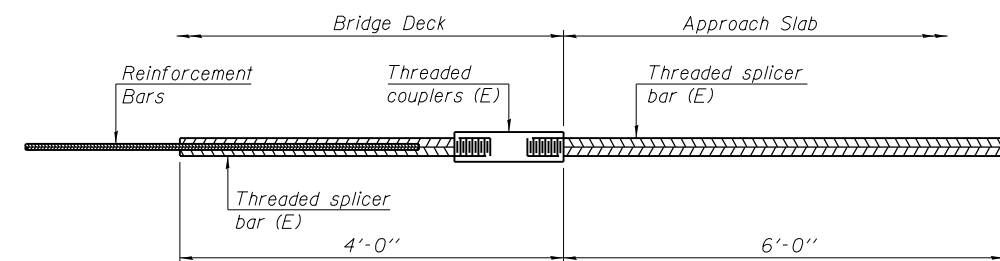

BAR SPLICER ASSEMBLY FOR #5 BAR ON INTEGRAL OR SEMI-INTEGRAL ABUTMENTS

No. required =

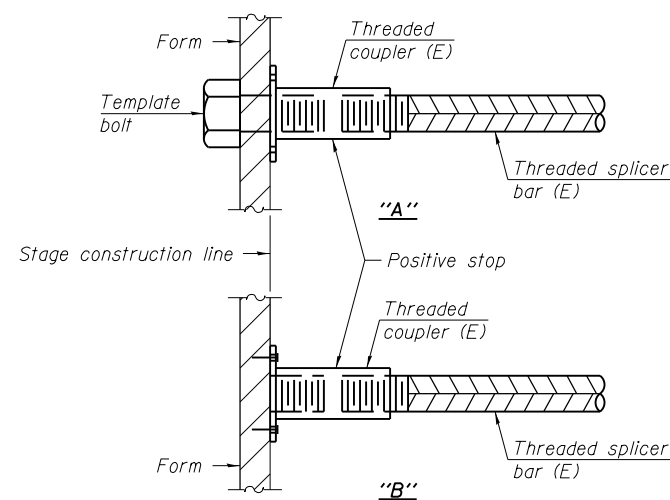

INSTALLATION AND SETTING METHODS

- "A" : Set bar splicer assembly by means of a template bolt.
- "B" : Set bar splicer assembly by nailing to wood forms or cementing to steel forms.
- (E) : Indicates epoxy coating.

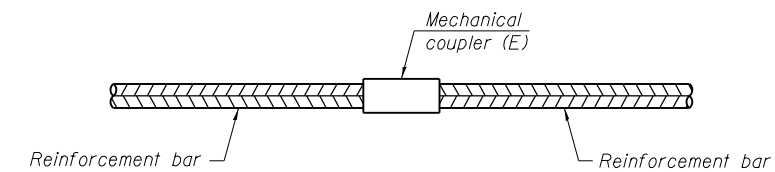

STANDARD MECHANICAL SPLICER

Location	Bar size	No. assemblies required

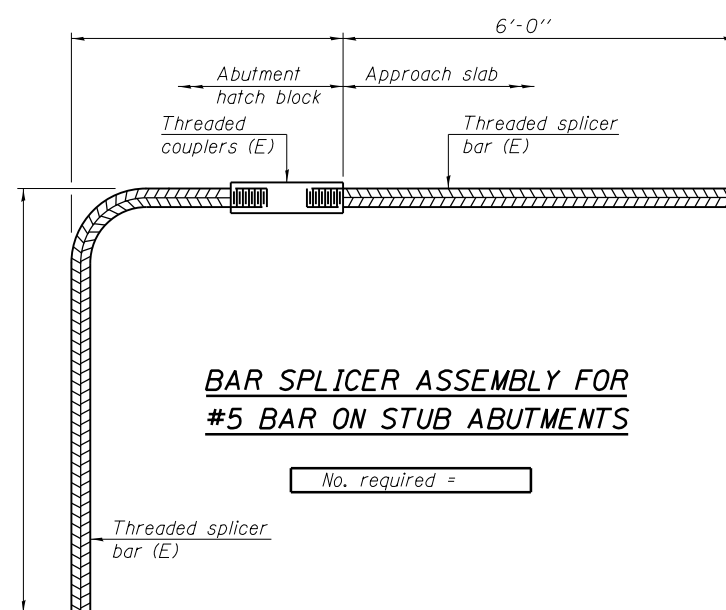

BAR SPLICER ASSEMBLY FOR #5 BAR ON STUB ABUTMENTS

No. required =

NOTES

- Splicer bars shall be deformed with threaded ends and have a minimum 60 ksi yield strength.
- All reinforcement shall be lapped and tied to the splicer bars.
- Bar splicer assemblies shall be epoxy coated according to the requirements for reinforcement bars. See Section 508 of the Standard Specifications.
- See special provision for Mechanical Splicers.
- See approved list of bar splicer assemblies and mechanical splicers for alternatives.

BSD-1 7-1-10
BENTON & ASSOCIATES, INC.

FILE NAME = P:\10e2166-2\Design\	USER NAME =	DESIGNED - MBH	REVISED - 10/3/13
Plans\082-0156 & 082-0157		CHECKED - SJH	REVISED -
0820156-76022-011-Splicer.dgn	PLOT SCALE =	DRAWN - MBH	REVISED -
	PLOT DATE =	CHECKED - SJH	REVISED -

STATE OF ILLINOIS
DEPARTMENT OF TRANSPORTATION

BAR SPLICER ASSEMBLY AND MECHANICAL SPLICER DETAILS
STRUCTURE NO. 082-0156 & 082-0157

SHEET NO. 11 OF 11 SHEETS

F.A.I. RTE.	SECTION	COUNTY	TOTAL SHEETS	SHEET NO.
64	82-1VBI / 82-1VBR	ST. CLAIR	208	158
CONTRACT NO. 76022				
FED. ROAD DIST. NO. 8 ILLINOIS FED. AID PROJECT				

INDEX OF SHEETS

General Plan & Elevation	1
Staging	2-3
Temporary Concrete Barrier For Stage Construction	4
Deck Repairs	5
Concrete Removal & Replacement	6
Preformed Joint Strip Seal	7
Bar Splicer Assembly Details	8

GENERAL NOTES

- All new structural steel shall conform to AASHTO Classification M270 Gr. 36 unless otherwise noted.
- Fasteners shall be AASHTO M164 Type 1, mechanically galvanized bolts (in painted areas and M164 Type 3 in unpainted areas). Bolts 1/2" φ, holes 5/16" φ, unless otherwise noted.
- No field welding is permitted except as specified in the contract documents.
- Reinforcement bars designated (E) shall be epoxy coated.
- Prior to pouring the new concrete deck, all heavy or loose rust, loose mill scale, and other loose or potentially detrimental foreign material shall be removed from the surfaces in contact with concrete. Tightly adhered paint may remain unless otherwise noted. Removal shall be accomplished by methods that will not damage the steel and the cost will be included in the pay item covering removal of the existing concrete.
- As directed by the Engineer, existing construction accessories welded to the top flange of beams and girders shall be removed. The weld areas shall be ground flush and inspected for cracks using magnetic particle testing (MT) or dye penetrant testing (PT) by qualified personnel approved by the Engineer. Any cracks that can not be removed by grinding 1/4 in. deep shall be identified and reported to the Bureau of Bridges and Structures for further disposition. The cost of removing welded accessories, grinding and inspecting weld areas and grinding cracks will be paid for according to Article 109.04 of the Standard Specifications.
- Plan dimensions and details relative to existing plans are subject to nominal construction variations. The Contractor shall field verify existing dimensions and details affecting new construction and make necessary approved adjustments prior to construction or ordering of materials. Such variations shall not be cause for additional compensation for a change in scope of the work, however, the Contractor will be paid for the quantity actually furnished at the unit price bid for the work.
- Existing reinforcement bars extending into the removal area shall be cleaned, straightened and incorporated into the new into the new construction. Any reinforcement bars that are damaged during concrete removal shall be replaced with an approved splicer or anchorage system. Cost included with Concrete Removal.
- Joint openings shall be adjusted according to Article 520.04 of the Std. Specs. when the deck is poured at an ambient temperature other than 50° F.
- Areas of deck repairs shown are estimated. The Engineer shall show actual locations of deck repairs on As-built Plans.
- The existing structural steel contains lead. The contractor shall take appropriate precautions to deal with the presence of lead on this project.
- All structural steel shall be shop painted with the inorganic zinc rich primer per AASHTO M300, Type 1. Color to match existing. Cost included with Furnishing and Erecting Structural Steel.
- Existing structural steel that will be in contact with new structural steel shall be cleaned and painted prior to erection as required by the Special Provisions "Cleaning & Painting Contact Surface Areas of Existing Steel Structures".

ORIGINAL DESIGN STRESSES

FIELD UNITS

f'c = 1,400 psi (Piers and Superstructure)
 f'c = 1,000 psi (Substructure w/ Earth Pressure)
 fy = 20,000 psi (Reinforcement)
 n = 10
 N = 75 psi

TOTAL BILL OF MATERIAL

ITEM	UNIT	QUANTITY
Concrete Removal	Cu. Yd.	26.8
Concrete Superstructure	Cu. Yd.	26.5
Bridge Deck Concrete Sealer	Sq. Ft.	18420
Furnishing and Erecting Structural Steel	Pound	2240
Reinforcement Bars, Epoxy Coated	Pound	3710
Preformed Joint Strip Seal	Foot	194
Deck Slab Repair (Full)	Sq. Yd.	3.6
Bar Splicers	Each	96
Protective Shield	Sq. Yd.	8
Anchor Bolts, 1"	Each	64



Reginald H. Benton
 10/3/13
 EXP 11/30/14

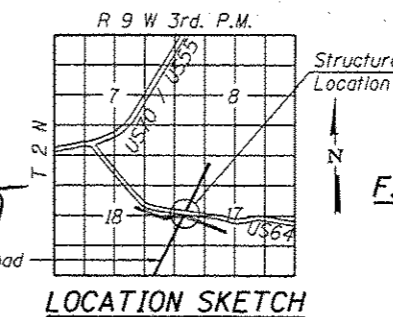

GENERAL PLAN & ELEVATION
INTERSTATE 64 OVER RAILROAD
F.A.I. RTE. 64 - SEC. 82-IVBI-1 / 82-IVBR-1
ST. CLAIR COUNTY
US 64 STA. 105+80.81
E. TRACK STA. 3+88.47

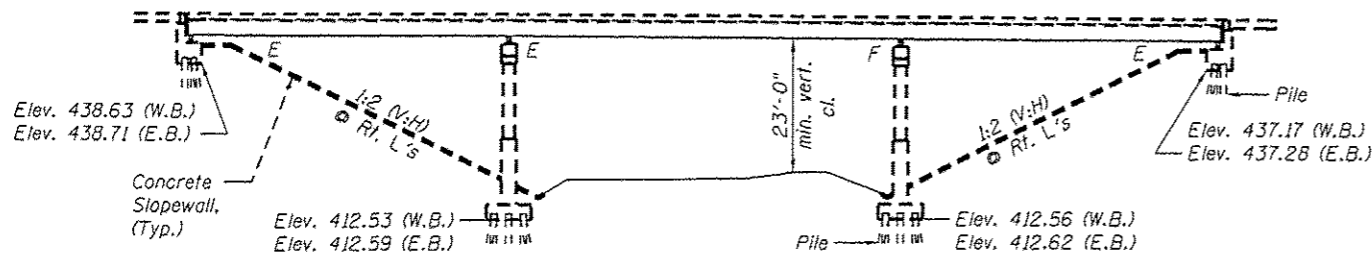

ELEVATION

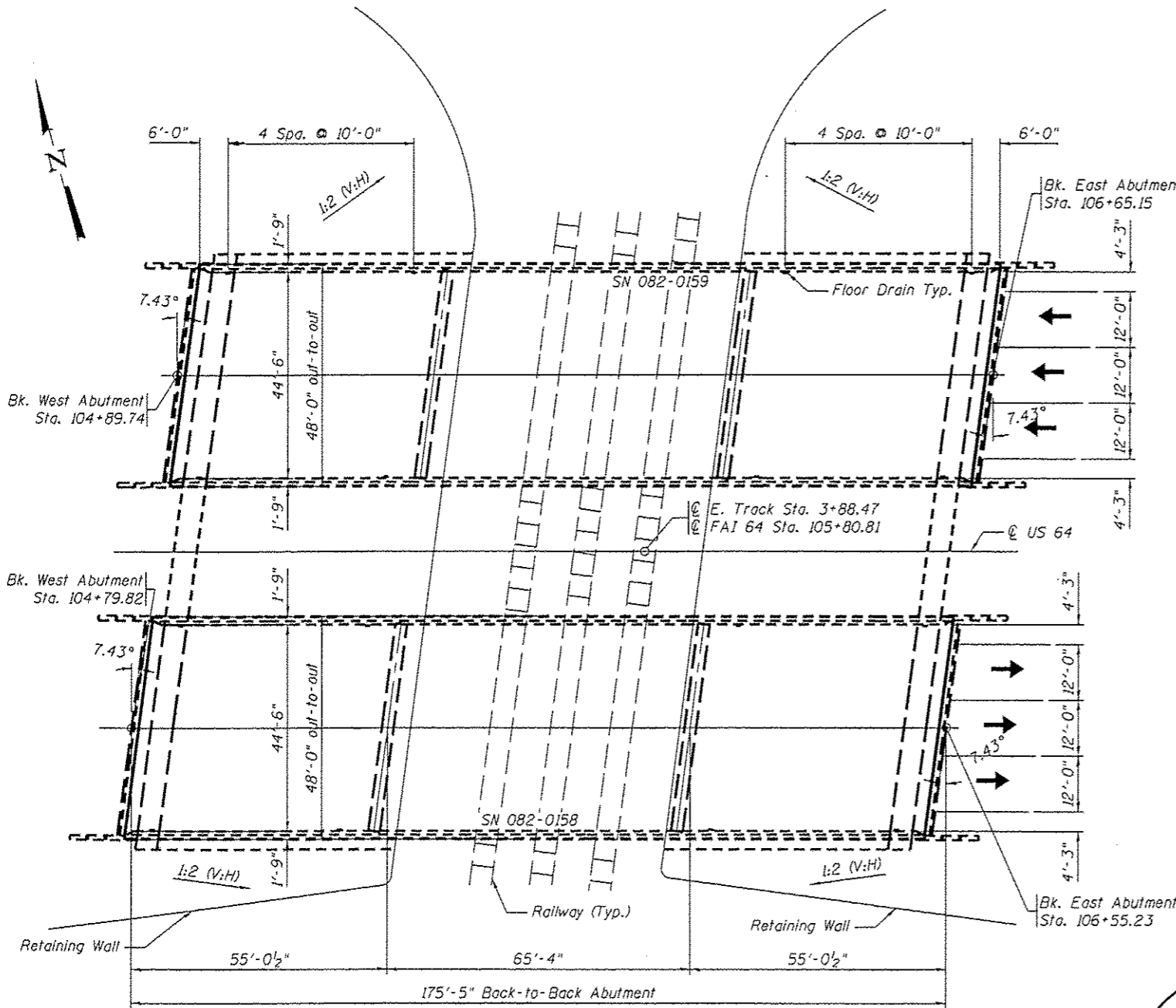

PLAN

BENTON & ASSOCIATES, INC.

STATE OF ILLINOIS
DEPARTMENT OF TRANSPORTATION

GENERAL PLAN & ELEVATION
STRUCTURE NO. 082-0158 & 082-0159

SHEET NO. 1 OF 8 SHEETS

FILE NAME : P:\18-2166-2\Design\	USER NAME :	DESIGNED - DJE	REVISED - 10/3/13
Plans\082-0158 & 082-0159		CHECKED - DJE	REVISED -
0820150-76022-001-CPE.dgn		DRAWN - DJE	REVISED -
		CHECKED -	REVISED -

F.A.I. RTE.	SECTION	COUNTY	TOTAL SHEETS	SHEET NO.
64	82-IVBI-1 / 82-IVBR-1	ST. CLAIR	208	159
CONTRACT NO. 76022			FED. ROAD DIST. NO. 8 ILLINOIS FED. AID PROJECT	

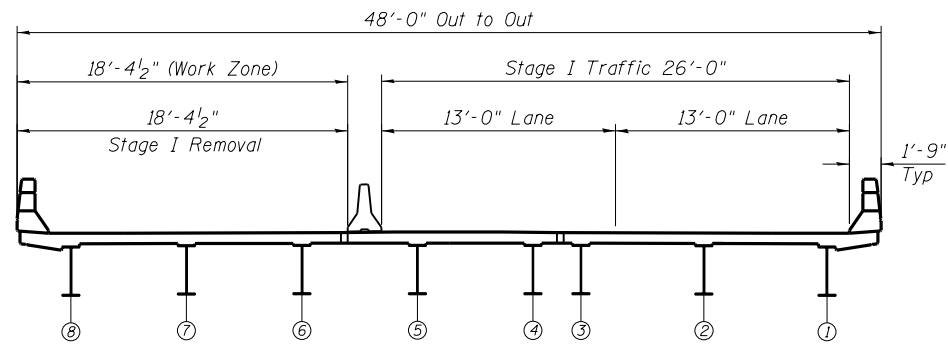

SN 082-0158 EASTBOUND CROSS SECTION
(Looking East)
STAGE I REMOVAL

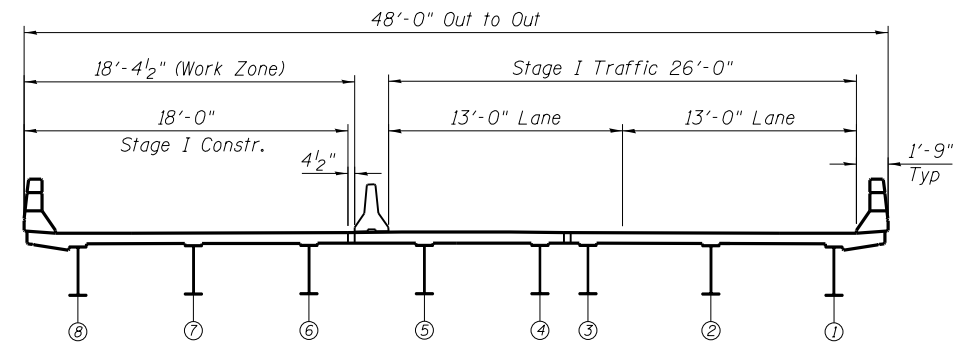

SN 082-0158 EASTBOUND CROSS SECTION
(Looking East)
STAGE I CONSTRUCTION

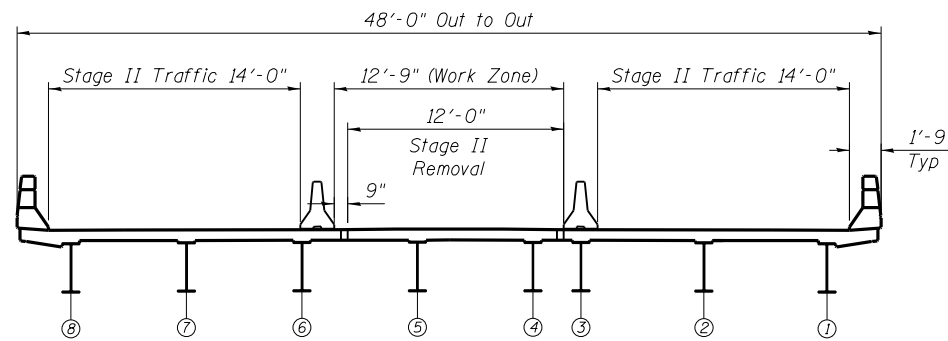

SN 082-0158 EASTBOUND CROSS SECTION
(Looking East)
STAGE II REMOVAL

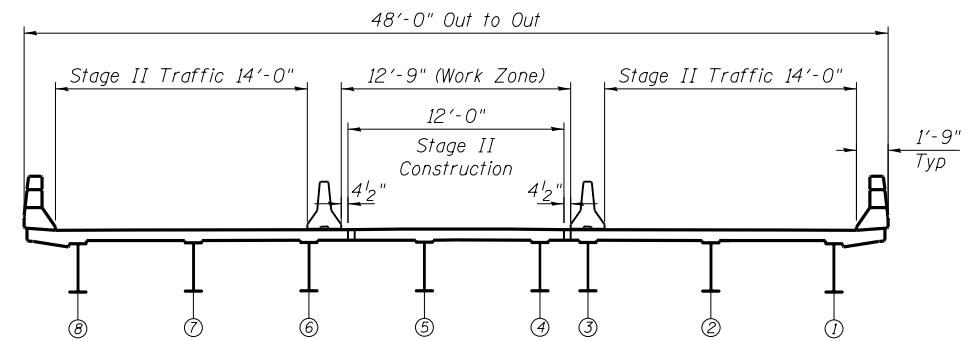

SN 082-0158 EASTBOUND CROSS SECTION
(Looking East)
STAGE II CONSTRUCTION

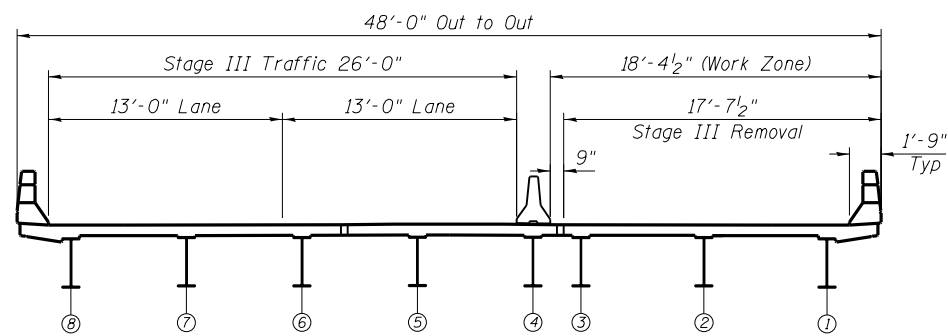

SN 082-0158 EASTBOUND CROSS SECTION
(Looking East)
STAGE III REMOVAL

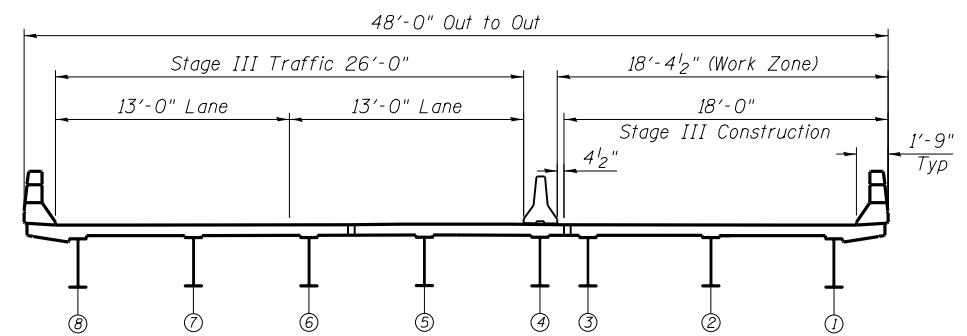

SN 082-0158 EASTBOUND CROSS SECTION
(Looking East)
STAGE III CONSTRUCTION

BENTON & ASSOCIATES, INC.

FILE NAME = P:\10e2166-2\Design\	USER NAME =	DESIGNED - MBH	REVISED -
Plans\082-0158 & 082-0159		CHECKED - SJH	REVISED -
0820158-76022-002-Staging.dgn	PLOT SCALE =	DRAWN - MBH	REVISED -
	PLOT DATE =	CHECKED - SJH	REVISED -

STATE OF ILLINOIS
DEPARTMENT OF TRANSPORTATION

STAGING SECTIONS
STRUCTURE NO. 082-0158

SHEET NO. 2 OF 8 SHEETS

F.A.I. RTE.	SECTION	COUNTY	TOTAL SHEETS	SHEET NO.
64	82-1VBI-1 / 82-1VBR-1	ST. CLAIR	208	160
CONTRACT NO. 76022				
FED. ROAD DIST. NO. 8 ILLINOIS FED. AID PROJECT				

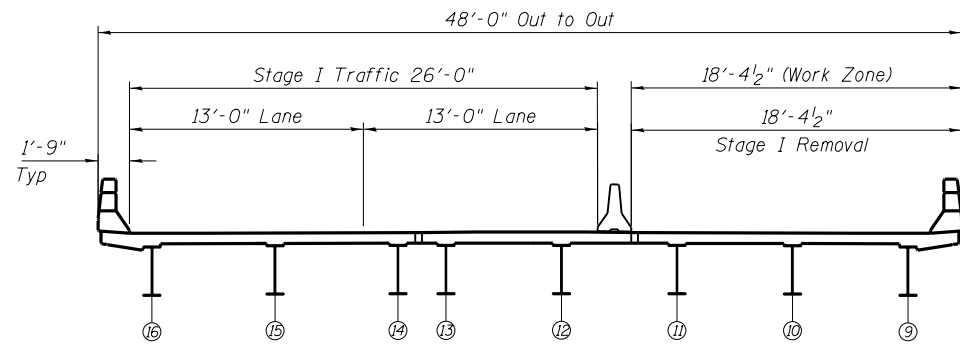

SN 082-0159 WESTBOUND CROSS SECTION
(Looking East)
STAGE I REMOVAL

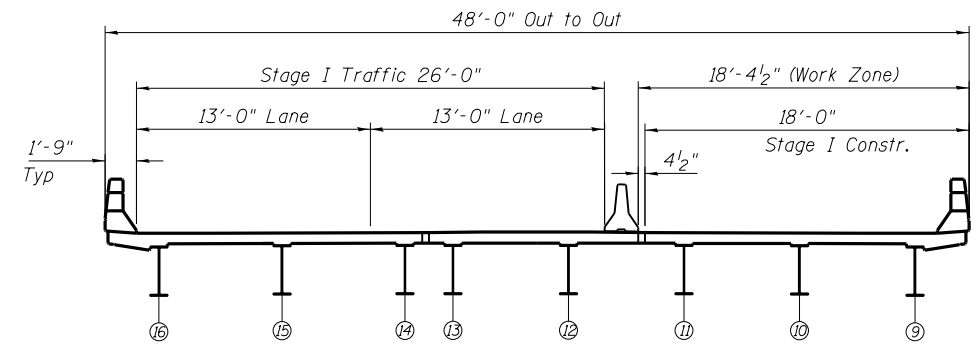

SN 082-0159 WESTBOUND CROSS SECTION
(Looking East)
STAGE I CONSTRUCTION

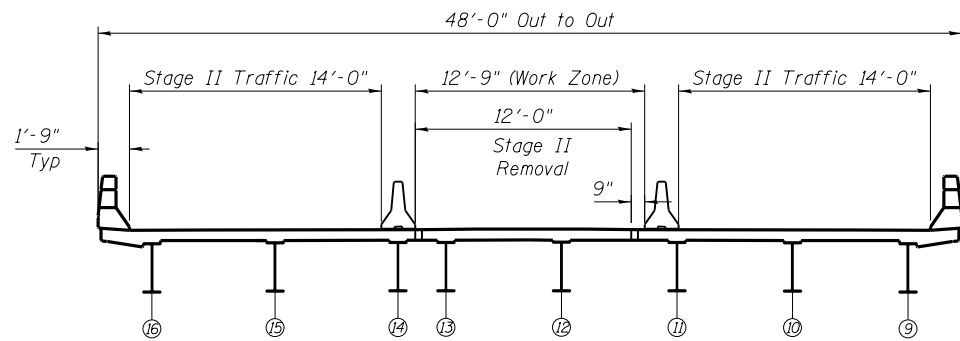

SN 082-0159 WESTBOUND CROSS SECTION
(Looking East)
STAGE II REMOVAL

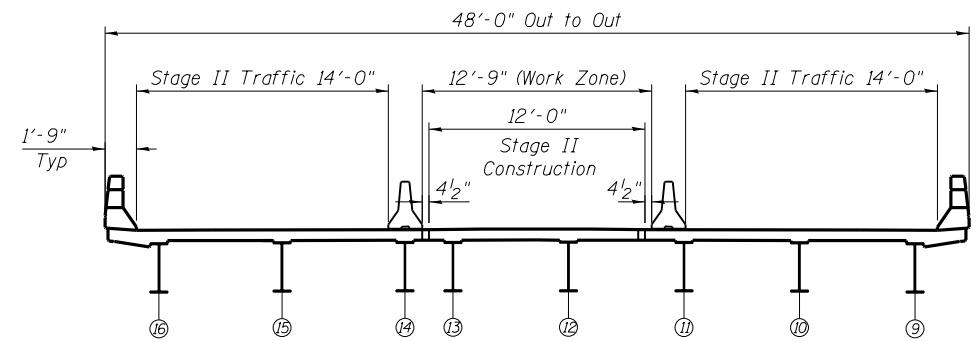

SN 082-0159 WESTBOUND CROSS SECTION
(Looking East)
STAGE II CONSTRUCTION

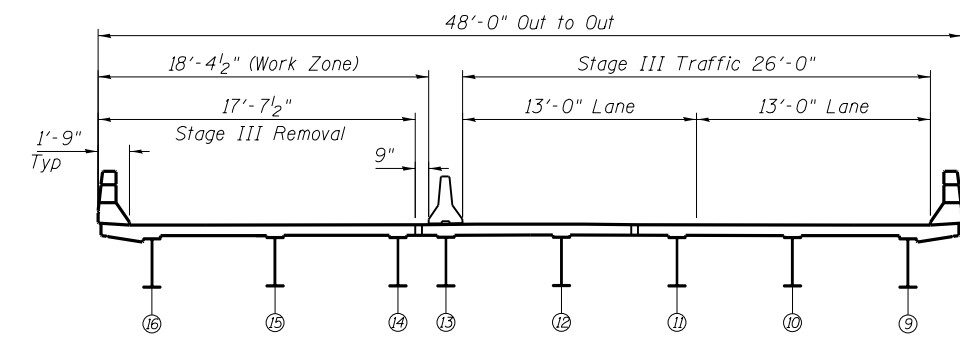

SN 082-0159 WESTBOUND CROSS SECTION
(Looking East)
STAGE III REMOVAL

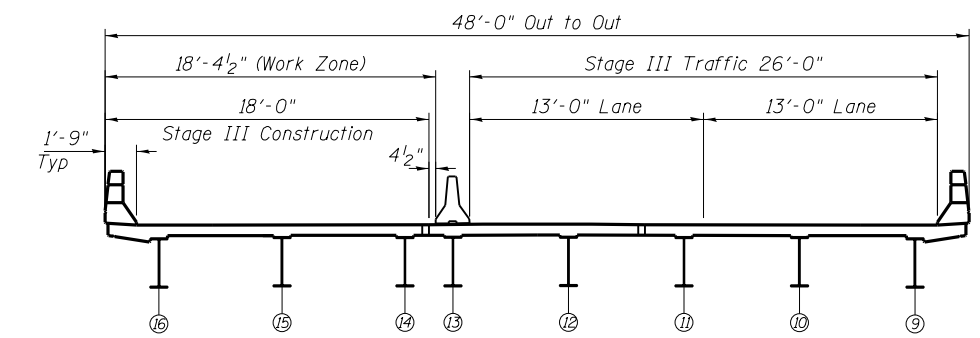

SN 082-0159 WESTBOUND CROSS SECTION
(Looking East)
STAGE III CONSTRUCTION

BENTON & ASSOCIATES, INC.

FILE NAME = P:\10e2166-2\Design\	USER NAME =	DESIGNED - MBH	REVISED - _____
Plans\082-0158 & 082-0159		CHECKED - SJH	REVISED - _____
0820158-76022-002-Staging.dgn	PLOT SCALE =	DRAWN - MBH	REVISED - _____
	PLOT DATE =	CHECKED - SJH	REVISED - _____

STATE OF ILLINOIS
DEPARTMENT OF TRANSPORTATION

STAGING SECTIONS
STRUCTURE NO. 082-0159

SHEET NO. 3 OF 8 SHEETS

F.A.I. RTE.	SECTION	COUNTY	TOTAL SHEETS	SHEET NO.
64	82-1VBI-1 / 82-1VBR-1	ST. CLAIR	208	161
CONTRACT NO. 76022				
FED. ROAD DIST. NO. 8 ILLINOIS FED. AID PROJECT				

When "A" is 3'-6" or less, the temporary concrete barrier shall be anchored to the new slab according to Detail I or Detail II. No anchorage is required when "A" is greater than 3'-6".

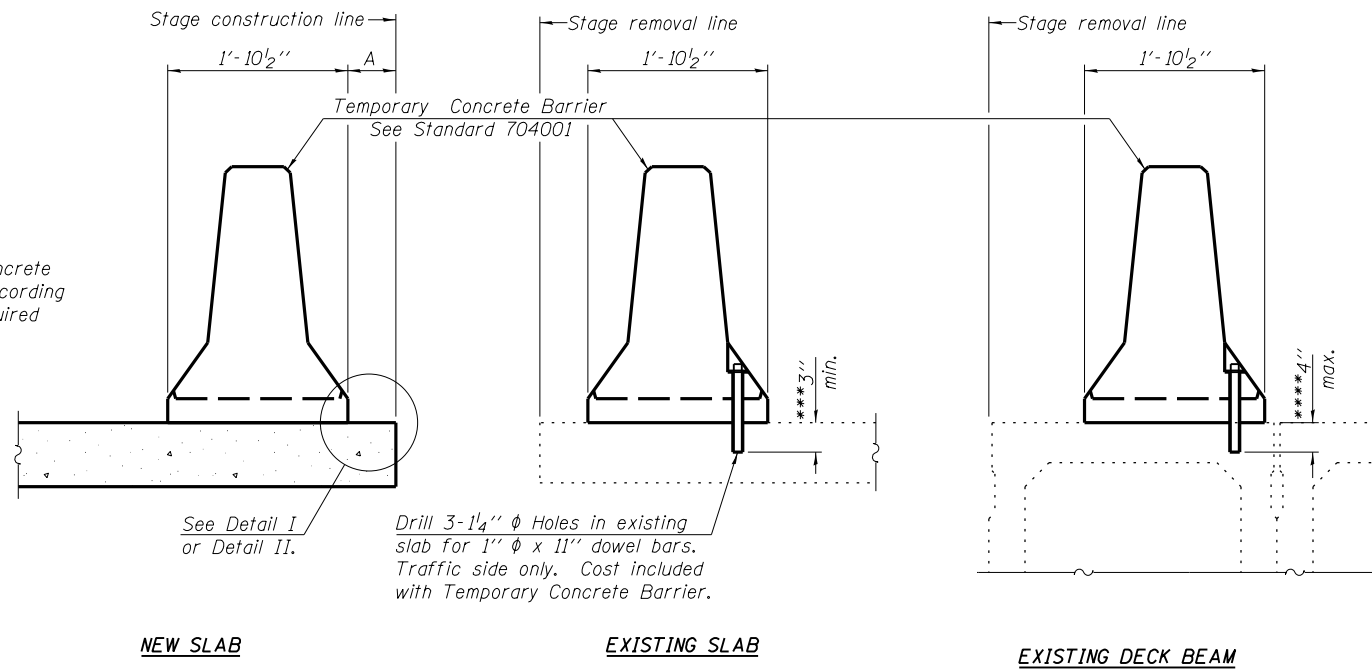

SECTIONS THRU SLAB OR DECK BEAM

NOTES

Detail I - With Bar Splicer or Couplers:
Connect one (1) 1" x 7" x "W" steel PL to the top layer of couplers with 2-5/8" φ bolts screwed to coupler at approximate C of each barrier panel.

Detail II - With Extended Reinforcement Bars:
Connect one (1) 1" x 7" x "W" steel PL to the concrete slab or concrete wearing surface with 2-5/8" φ Expansion Anchors or cast in place inserts spaced between the top layer of reinforcement at approximate C of each barrier panel.

Cost of anchorage is included with Temporary Concrete Barrier. The 1" x 7" x "W" plate shall not be removed until stage II construction forms and all reinforcement bars are in place and the concrete is ready to be placed.

*** Dimension shown is minimum required embedment into concrete. If hot-mix asphalt wearing surface is present, minimum embedment shall be in addition to wearing surface depth.

**** If existing deck beam is to remain in place after stage construction, embedment shall only be into wearing surface and not into existing deck beam concrete.

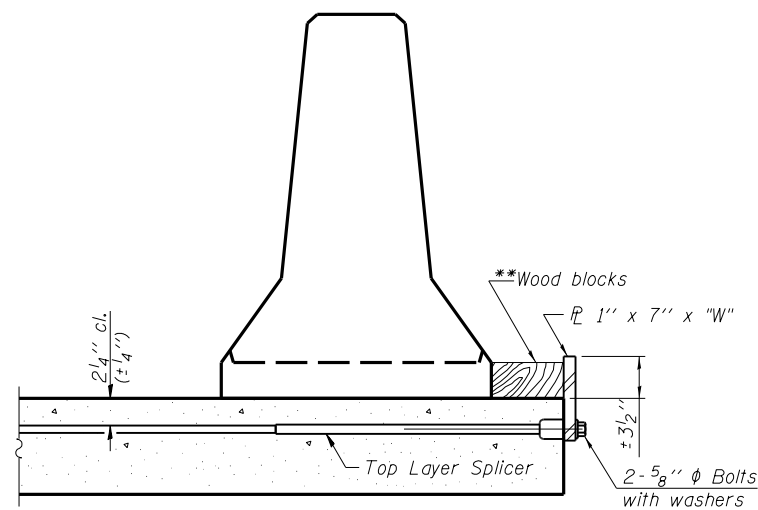

DETAIL I

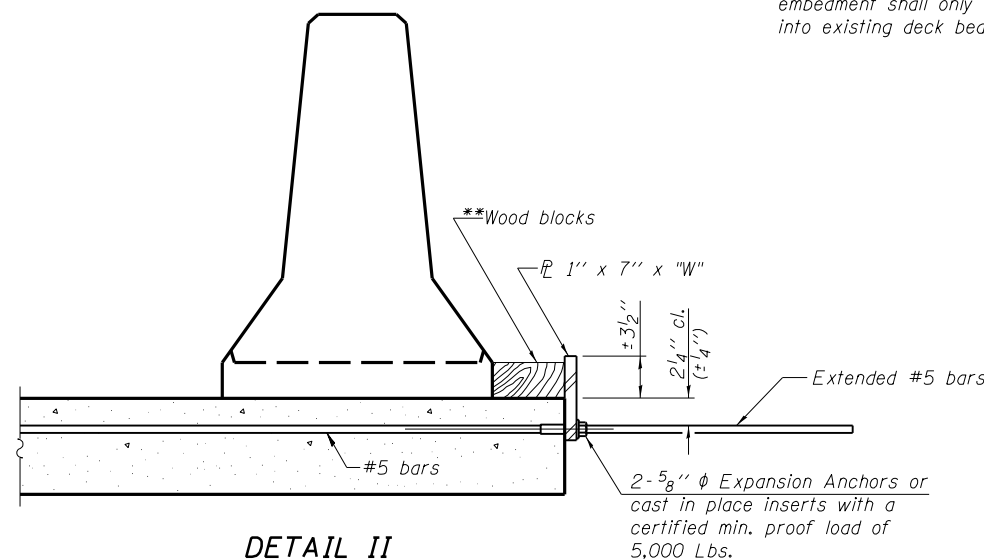

DETAIL II

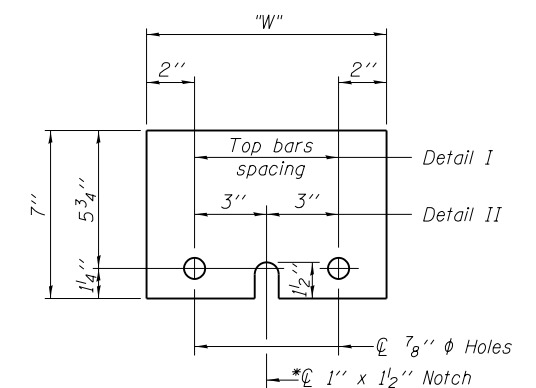

STEEL RETAINER PL 1" x 7" x "W"

* Required only with Detail II

** Wood blocks may be omitted when required to provide minimum stage traffic lane width. When the wood blocks are omitted, the concrete barrier shall be in direct contact with the steel retainer plate.

"W" = Top bars spacing + 4"

R-27 7-1-10
BENTON & ASSOCIATES, INC.

FILE NAME = P:\10e2166-2\Design\	USER NAME =	DESIGNED - MBH	REVISED -
Plans\082-0158 & 082-0159		CHECKED - SJH	REVISED -
0820158-76022-003-Barrier.dgn	PLOT SCALE =	DRAWN - MBH	REVISED -
	PLOT DATE =	CHECKED - SJH	REVISED -

STATE OF ILLINOIS
DEPARTMENT OF TRANSPORTATION

TEMPORARY CONCRETE BARRIER FOR STAGE CONSTRUCTION
STRUCTURE NO. 082-0158 & 082-0159

SHEET NO. 4 OF 8 SHEETS

F.A.I. RTE.	SECTION	COUNTY	TOTAL SHEETS	SHEET NO.
64	82-1HB1-2	ST. CLAIR	208	162
CONTRACT NO. 76022				
FED. ROAD DIST. NO. 8 ILLINOIS FED. AID PROJECT				

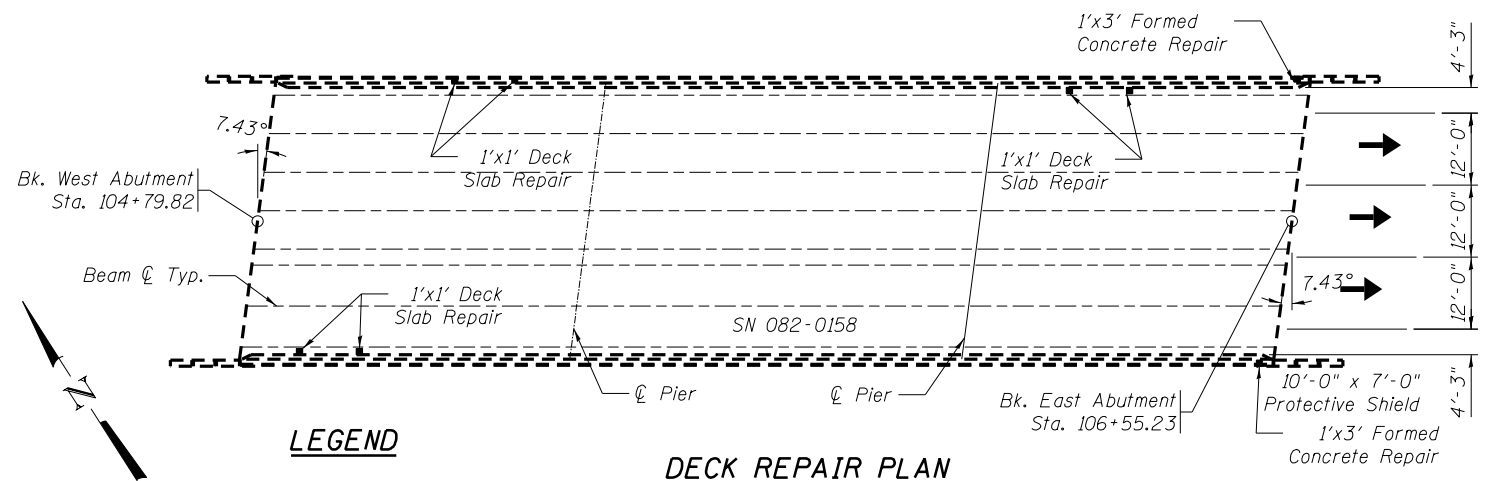
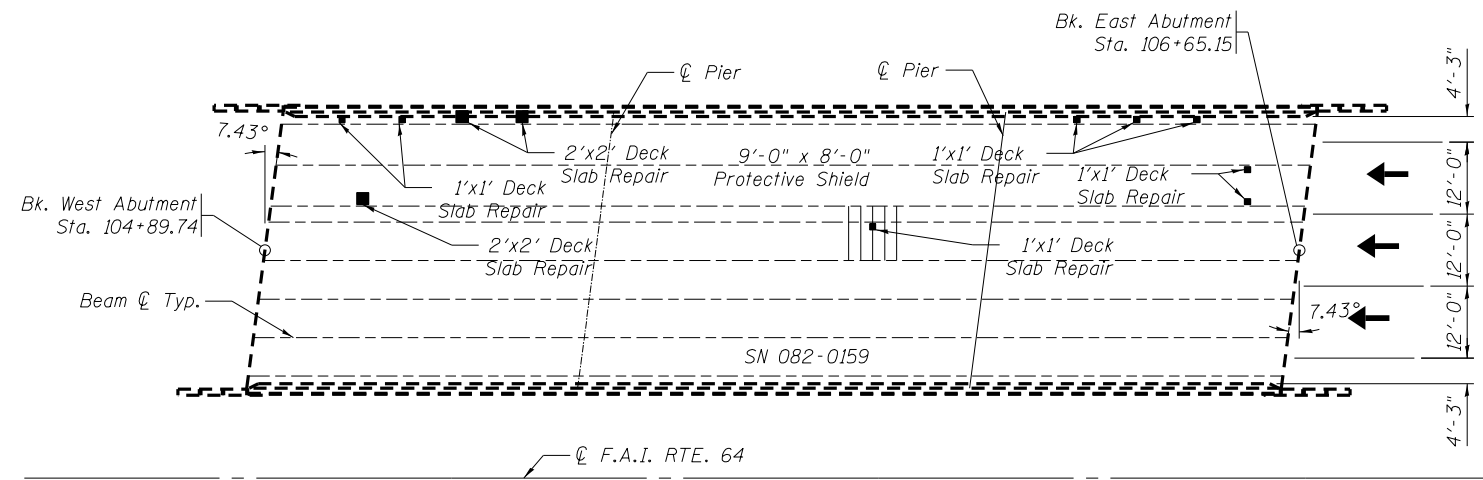

LEGEND

■ Area of Full Depth Deck Repair

DECK REPAIR PLAN

BILL OF MATERIAL

ITEM	UNIT	QUANTITY
Deck Slab Repair (Full)	Sq. Yd.	3.6
Furnishing and Erecting Structural Steel	Pound	2240
Protective Shield	Sq. Yd.	8
Anchor Bolts, 1"	Each	64

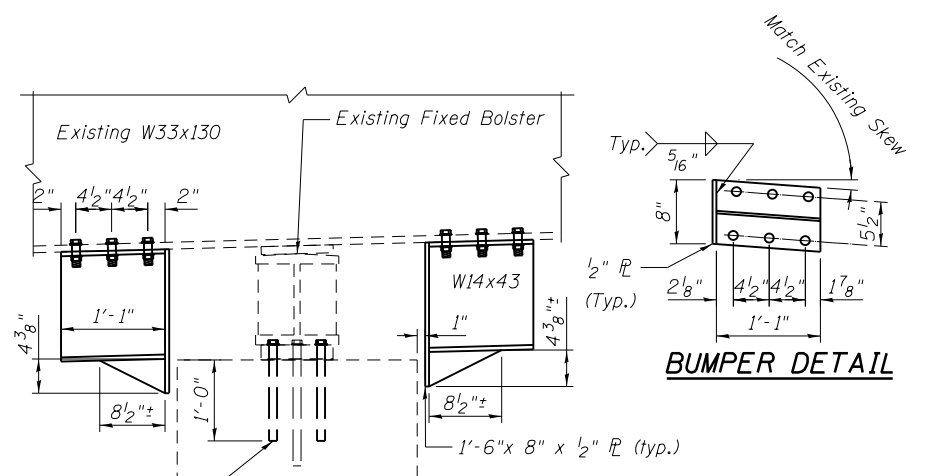

NEW BUMPERS

(At Existing Fixed Bearing Bolster on East Pier on both structures)

Notes:
 The bumpers shall be galvanized after shop fabrication according to AASHTO M 232.
 Anchor bolts and plate washers shall be galvanized according to AASHTO M 232.

BENTON & ASSOCIATES, INC.

FILE NAME = P:\10e2166-2\Design\	USER NAME =	DESIGNED - MBH	REVISED - 10/3/13
Plans\082-0158 & 082-0159		CHECKED - SJH	REVISED -
0820158-76022-004-Deck.dgn	PLOT SCALE =	DRAWN - MBH	REVISED -
	PLOT DATE =	CHECKED - SJH	REVISED -

**STATE OF ILLINOIS
 DEPARTMENT OF TRANSPORTATION**

**DECK REPAIRS
 STRUCTURE NO. 082-0158 & 082-0159**

SHEET NO. 5 OF 8 SHEETS

F.A.I. RTE.	SECTION	COUNTY	TOTAL SHEETS	SHEET NO.
64	82-1VBI-1 / 82-1VBR-1	ST. CLAIR	208	163
CONTRACT NO. 76022				
FED. ROAD DIST. NO. 8 ILLINOIS FED. AID PROJECT				

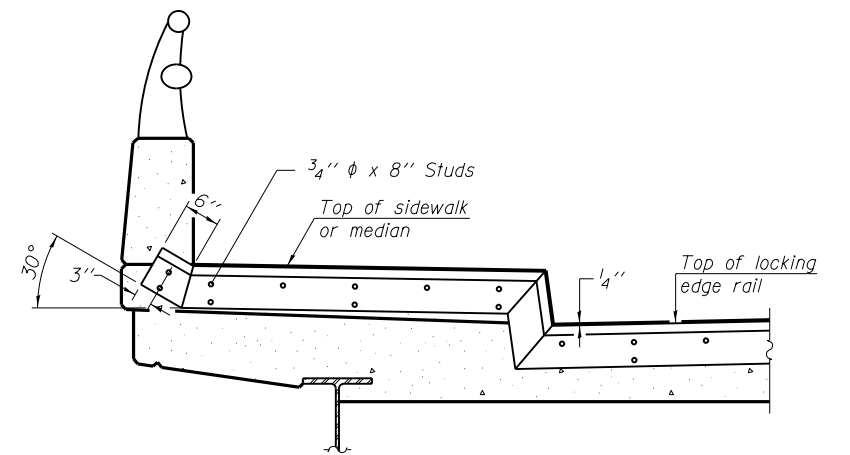
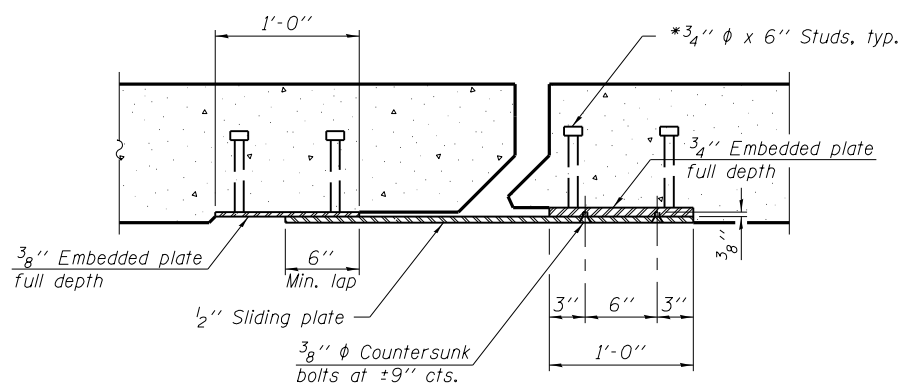
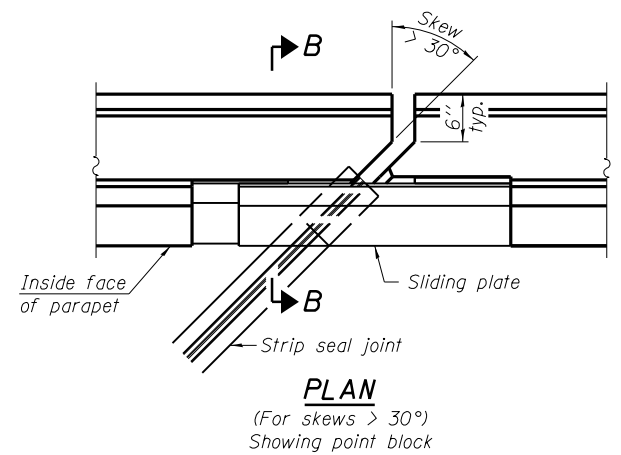
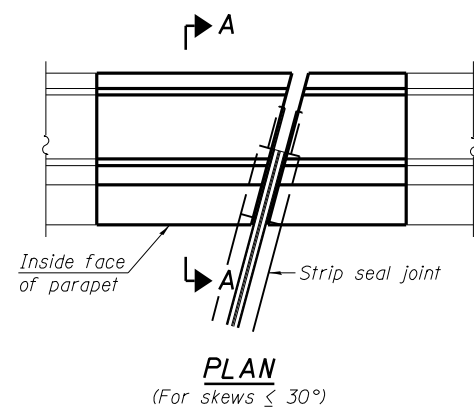

TYPICAL END TREATMENT AT SIDEWALK OR MEDIAN
 Shorter plates with a single row of studs at 12" cts. may be necessary on medians which are shallower than 9". See manufacturer's recommendation.

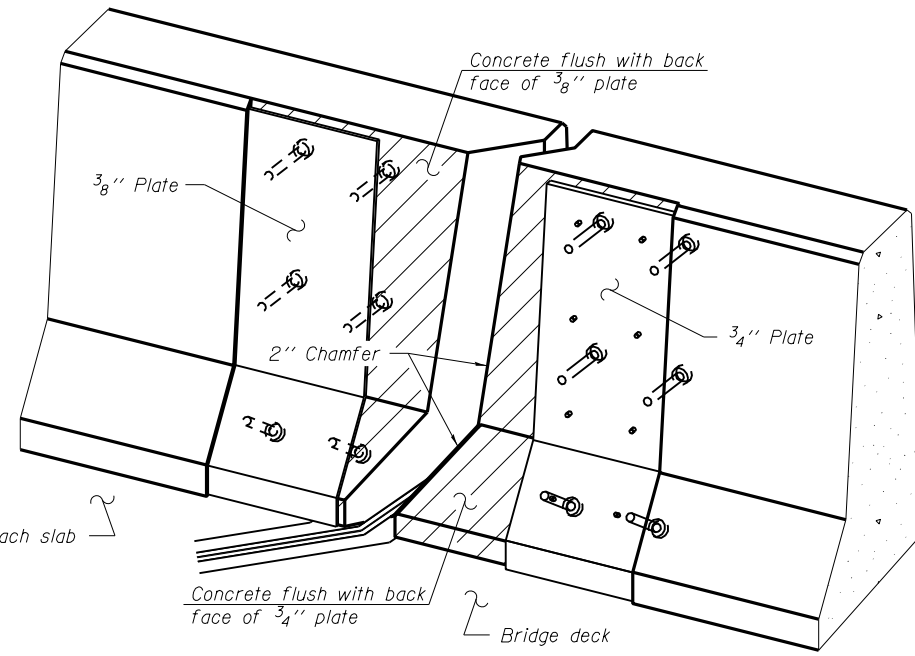
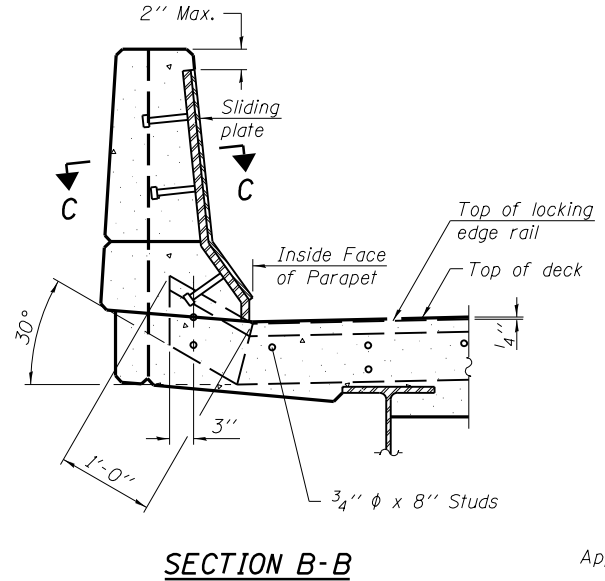
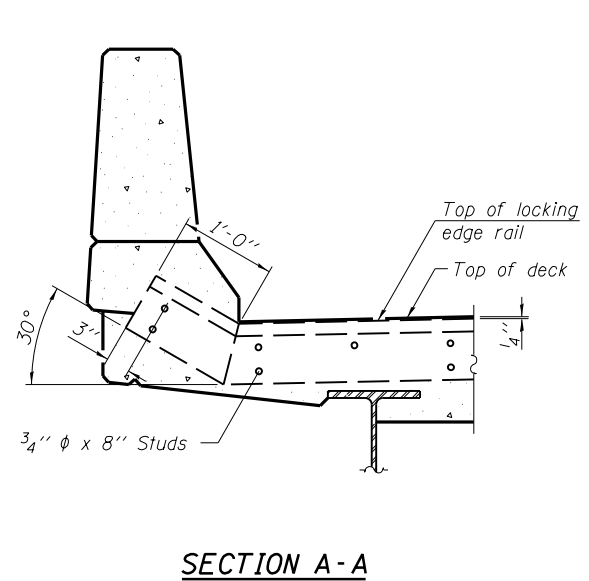

Notes:
 The strip seal shall be made continuous and shall have a minimum thickness of 1/4". The configuration of the strip seal shall match the configuration of the Locking Edge Rails. Open or "webbed" strip seal gland configurations are not permitted. The gland shall be sized for a maximum rated movement of 4 inches.
 The Locking Edge Rails depicted are conceptual only, except for the minimum dimensions shown. The actual configuration of the Locking Edge Rails and matching strip seal may vary from manufacturer to manufacturer. Flanged edge rails will not be allowed. Locking Edge Rails may be spliced at slope discontinuities.
 The manufacturer's recommended installation methods shall be followed.
 The joint opening and deck dimensions detailed on the superstructure are based on a rolled rail expansion joint. If the Contractor elects to use the welded rail expansion joint, the opening and deck dimensions shall be modified according to the dimensions detailed on this sheet. Required modifications shall be made at no additional cost to the State.
 All steel components shall be galvanized after fabrication according to Article 520.03 of the Standard Specifications.
 Maximum space between rail segments at stage lines shall be 3/16", sealed with a suitable sealant.
 Parapet plates and anchorage studs for skews > 30 degrees included in the cost of Preformed Joint Strip Seal.

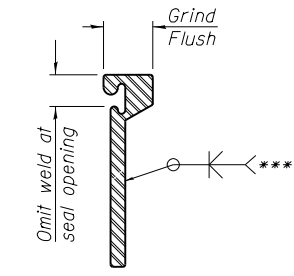
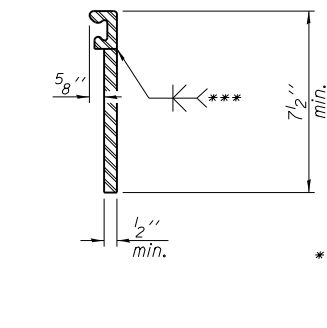
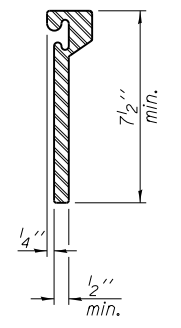
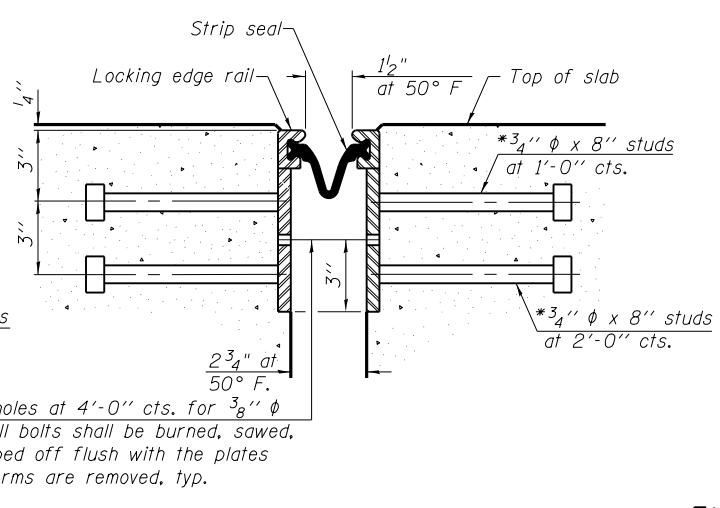
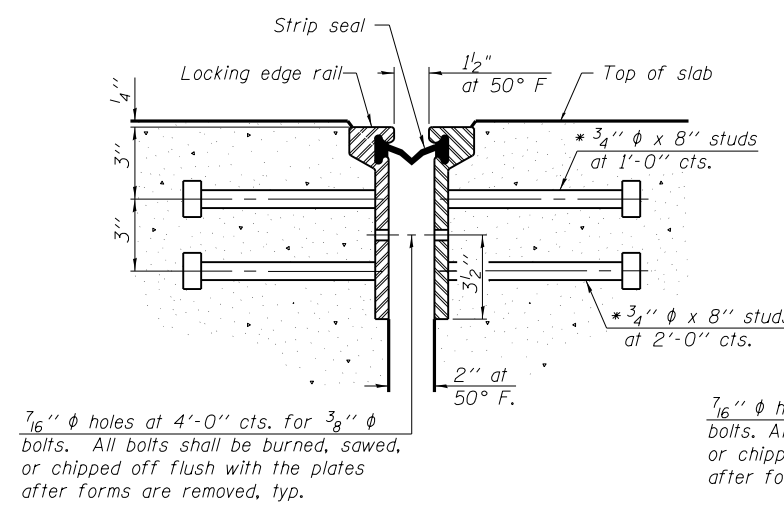

ROLLED EXTRUDED RAIL
WELDED RAIL

LOCKING EDGE RAIL SPLICE
 The inside of the locking edge rail groove shall be free of weld residue.
 Rolled rail shown, welded rail similar.

LOCKING EDGE RAILS

BILL OF MATERIAL

Item	Unit	Total
Preformed Joint Strip Seal	Foot	194

EJ-SSJ 7-1-10
BENTON & ASSOCIATES, INC.

* Granular or solid flux filled headed studs conforming to Article 1006.32 of the Std. Specs., automatically end welded.

FILE NAME: P:\10e2166-2\ Design\ Plans\ 082-0158 & 082-0159	USER NAME: _____	DESIGNED - DJE	REVISED - _____
0820158-76022-006-Joint.dgn	PLOT SCALE: _____	CHECKED - --	REVISED - _____
	PLOT DATE: _____	DRAWN - DJE	REVISED - _____
		CHECKED - --	REVISED - _____

STATE OF ILLINOIS
DEPARTMENT OF TRANSPORTATION

PREFORMED JOINT STRIP SEAL
STRUCTURE NO. 082-0158 & 082-0159

SHEET NO. 7 OF 8 SHEETS

F.A.I. RTE.	SECTION	COUNTY	TOTAL SHEETS	SHEET NO.
64	82-1VBI-1 / 82-1VBR-1	ST. CLAIR	208	165
CONTRACT NO. 76022				
FED. ROAD DIST. NO. 8 ILLINOIS FED. AID PROJECT				

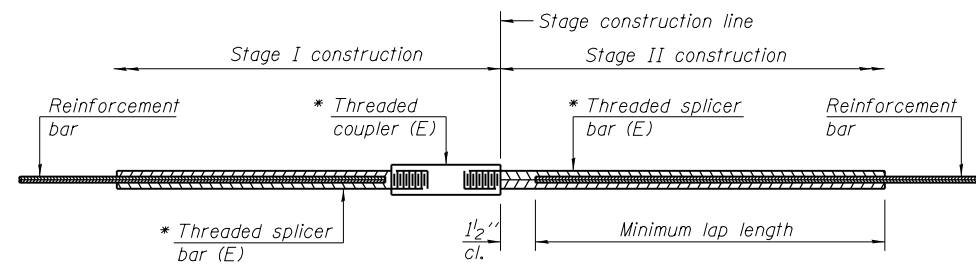

STANDARD BAR SPLICER ASSEMBLY

Minimum Lap Lengths					
Bar size to be spliced	Table 1	Table 2	Table 3	Table 4	Table 5
3, 4	1'-5"	1'-11"	2'-1"	2'-4"	2'-3"
5	1'-9"	2'-5"	2'-7"	2'-11"	2'-10"
6	2'-1"	2'-11"	3'-1"	3'-6"	3'-4"
7	2'-9"	3'-10"	4'-2"	4'-8"	4'-6"
8	3'-8"	5'-1"	5'-5"	6'-2"	5'-10"
9	4'-7"	6'-5"	6'-10"	7'-9"	7'-5"

- Table 1: Black bar, 0.8 Class C
- Table 2: Black bar, Top bar lap, 0.8 Class C
- Table 3: Epoxy bar, 0.8 Class C
- Table 4: Epoxy bar, Top bar lap, 0.8 Class C
- Table 5: Epoxy bar, Top bar lap, Class B

Threaded splicer bar length = min. lap length + 1/2" + thread length

* Epoxy not required on Bar Splicer Assembly components used in conjunction with black bars.

Location	Bar size	No. assemblies required	Table for minimum lap length
SN 082-0158 Deck	#6	32	Table 3
SN 082-0158 Hatch	#6	16	Table 3
SN 082-0159 Deck	#6	32	Table 3
SN 082-0159 Hatch	#6	16	Table 3

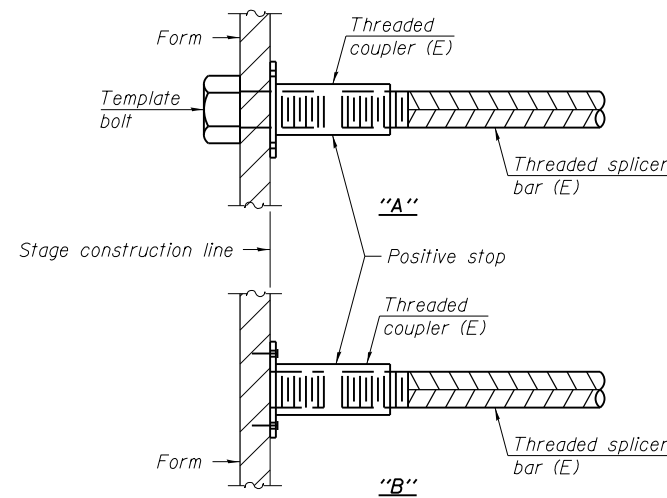

INSTALLATION AND SETTING METHODS

"A" : Set bar splicer assembly by means of a template bolt.
 "B" : Set bar splicer assembly by nailing to wood forms or cementing to steel forms.
 (E) : Indicates epoxy coating.

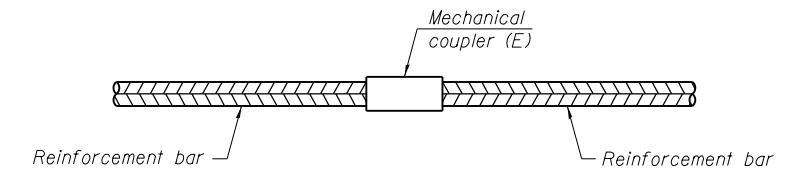

STANDARD MECHANICAL SPLICER

Location	Bar size	No. assemblies required

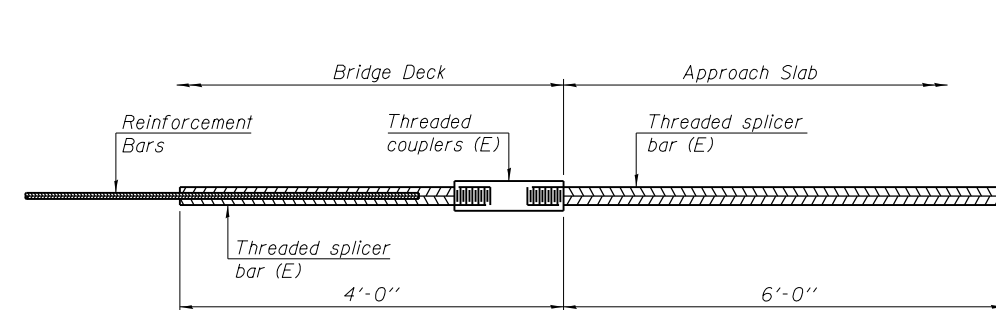

BAR SPLICER ASSEMBLY FOR #5 BAR ON INTEGRAL OR SEMI-INTEGRAL ABUTMENTS

No. required =

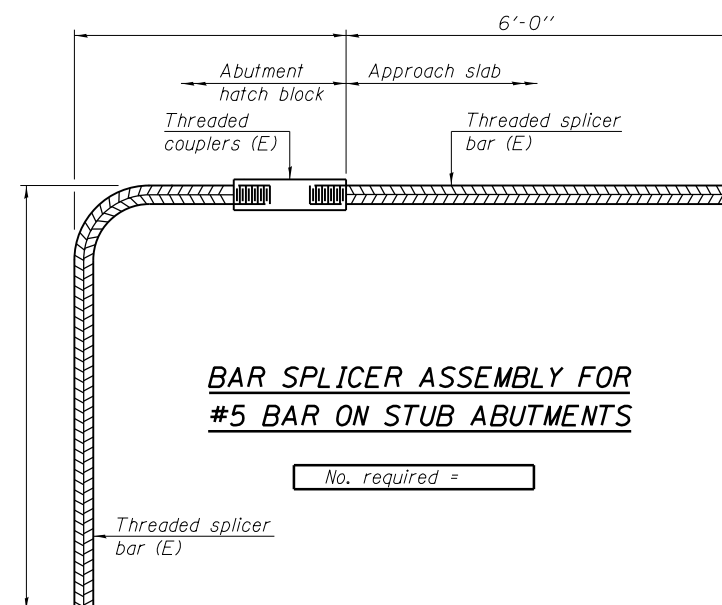

BAR SPLICER ASSEMBLY FOR #5 BAR ON STUB ABUTMENTS

No. required =

NOTES

- Splicer bars shall be deformed with threaded ends and have a minimum 60 ksi yield strength.
- All reinforcement shall be lapped and tied to the splicer bars.
- Bar splicer assemblies shall be epoxy coated according to the requirements for reinforcement bars. See Section 508 of the Standard Specifications.
- See special provision for Mechanical Splicers.
- See approved list of bar splicer assemblies and mechanical splicers for alternatives.

BSD-1 7-1-10
 BENTON & ASSOCIATES, INC.

FILE NAME = P:\10e2166-2\Design\Plans\082-0158 & 082-0159\0820158-76022-008-Splicer.dgn	USER NAME =	DESIGNED - MBH	REVISED - 10/3/13
		CHECKED - SJH	REVISED -
	PLOT SCALE =	DRAWN - MBH	REVISED -
	PLOT DATE =	CHECKED - SJH	REVISED -

STATE OF ILLINOIS
 DEPARTMENT OF TRANSPORTATION

BAR SPLICER ASSEMBLY AND MECHANICAL SPLICER DETAILS
 STRUCTURE NO. 082-0158 & 082-0159

SHEET NO. 8 OF 8 SHEETS

F.A.I. RTE.	SECTION	COUNTY	TOTAL SHEETS	SHEET NO.
64	82-1VBI-1 / 82-1VBR-1	ST. CLAIR	208	166
CONTRACT NO. 76022				
FED. ROAD DIST. NO. 8 ILLINOIS FED. AID PROJECT				

INDEX OF SHEETS

General Plan & Elevation	1
Staging	2-3
Temporary Concrete Barrier For Stage Construction	4
Deck Repairs	5
Concrete Removal & Replacement	6-8
Preformed Joint Strip Seal	9
Bar Splicer Assembly Details	10

GENERAL NOTES

- All new structural steel shall conform to AASHTO Classification M270 Gr. 36 unless otherwise noted.
- Fasteners shall be AASHTO M164 Type 1, mechanically galvanized bolts (in painted areas and M164 Type 3 in unpainted areas). Bolts $\frac{1}{8}$ " ϕ , holes $\frac{15}{16}$ " ϕ , unless otherwise noted.
- No field welding is permitted except as specified in the contract documents.
- Reinforcement bars designated (E) shall be epoxy coated.
- Prior to pouring the new concrete deck, all heavy or loose rust, loose mill scale, and other loose or potentially detrimental foreign material shall be removed from the surfaces in contact with concrete. Tightly adhered paint may remain unless otherwise noted. Removal shall be accomplished by methods that will not damage the steel and the cost will be included in the pay item covering removal of the existing concrete.
- As directed by the Engineer, existing construction accessories welded to the top flange of beams and girders shall be removed. The weld areas shall be ground flush and inspected for cracks using magnetic particle testing (MT) or dye penetrant testing (PT) by qualified personnel approved by the Engineer. Any cracks that can not be removed by grinding $\frac{1}{4}$ in. deep shall be identified and reported to the Bureau of Bridges and Structures for further disposition. The cost of removing welded accessories, grinding and inspecting weld areas and grinding cracks will be paid for according to Article 109.04 of the Standard Specifications.
- Plan dimensions and details relative to existing plans are subject to nominal construction variations. The Contractor shall field verify existing dimensions and details affecting new construction and make necessary approved adjustments prior to construction or ordering of materials. Such variations shall not be cause for additional compensation for a change in scope of the work, however, the Contractor will be paid for the quantity actually furnished at the unit price bid for the work.
- Existing reinforcement bars extending into the removal area shall be cleaned, straightened and incorporated into the new construction. Any reinforcement bars that are damaged during concrete removal shall be replaced with an approved bar splicer or anchorage system. Cost included with Concrete Removal.
- Joint openings shall be adjusted according to Article 520.04 of the Standard Specs. when the deck is poured at an ambient temperature other than 50° F.
- Areas of deck repairs shown are estimated. The Engineer shall show actual locations of deck repairs on As-built Plans.
- The existing structural steel contains lead. The contractor shall take appropriate precautions to deal with the presence of lead on this project.
- All structural steel shall be shop painted with the inorganic zinc rich primer per AASHTO M300, Type 1. Color to match existing. Cost included with Furnishing and Erecting Structural Steel.
- Existing structural steel that will be in contact with new structural steel shall be cleaned and painted prior to erection as required by the Special Provisions "Cleaning & Painting Contact Surface Areas of Existing Steel Structures".

RAMP "G" CURVE DATA

PI STA. = 2+05.31
 $\Delta = 8^\circ 3' 42''$
 $D_c = 1^\circ 58' 00''$
 $R = 2,913.55'$
 $L = 409.94'$
 $T = 205.31'$
 $E = 7.22'$

ELEVATION

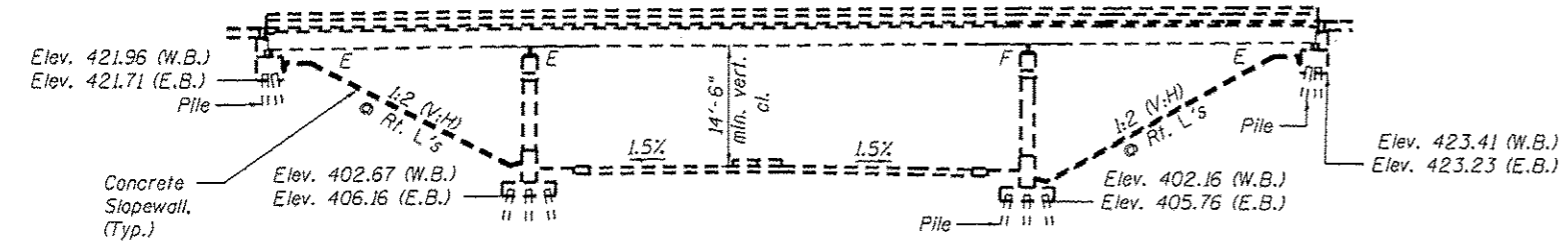

TOTAL BILL OF MATERIAL

ITEM	UNIT	QUANTITY
Concrete Removal	Cu. Yd.	29.0
Concrete Superstructure	Cu. Yd.	28.6
Bridge Deck Concrete Sealer	Sq. Ft.	21300
Furnishing and Erecting Structural Steel	Pound	2520
Reinforcement Bars, Epoxy Coated	Pound	4170
Preformed Joint Strip Seal	Foot	221
Deck Slab Repair (Partial)	Sq. Yd.	5.7
Deck Slab Repair (Full)	Sq. Yd.	1.3
Bar Splicers	Each	96
Remove and Re-erect Existing Lighting Unit	Each	1
Protective Shield	Sq. Yd.	63
Anchor Bolt, 1"	Each	72

ORIGINAL DESIGN STRESSES

FIELD UNITS
 $f'_c = 1,400$ psi (Superstructure)
 $f'_c = 1,200$ psi (Substructure, Piers, & Curb)
 $f_y = 20,000$ psi (Reinforcement)
 $f_y = 20,000$ psi (Structural Steel A36)
 $n = 10$
 $N = 75$ psi



Reginald H. Benton
 08/20/13 EXP 11/30/14

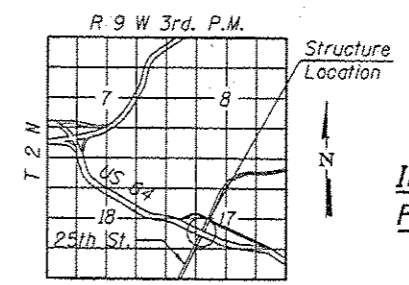

GENERAL PLAN & ELEVATION
INTERSTATE 64 OVER 25TH ST.
F.A.I. RTE. 64 - SEC. 82-2HB1
ST. CLAIR COUNTY
US 64 STA. 120+87.29
25TH ST. STA. 20+00.00

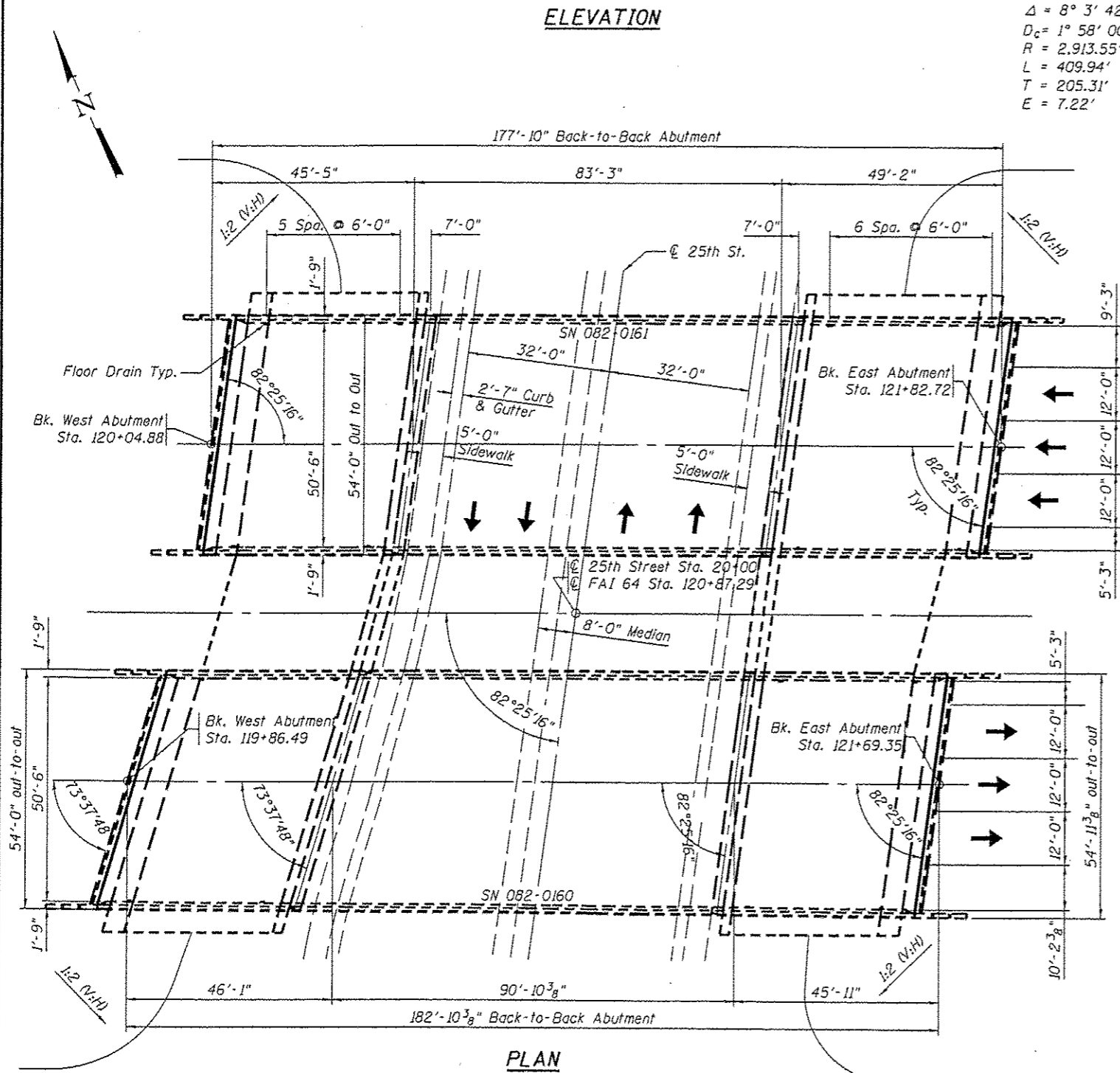

PLAN

BENTON & ASSOCIATES, INC.

FILE NAME = Prt_1802166-21 Design\	USER NAME =	DESIGNED - MBH	REVISED -
Plans\ 082-0160 & 082-0161		CHECKED - SJH	REVISED -
0820160-76022-001-GPE.dgn		DRAWN - JAS	REVISED -
		CHECKED - SJH	REVISED -

STATE OF ILLINOIS
DEPARTMENT OF TRANSPORTATION

GENERAL PLAN & ELEVATION
STRUCTURE NO. 082-0160 & 082-0161

F.A.I. RTE.	SECTION	COUNTY	TOTAL SHEETS	SHEET NO.
64	82-2HB1	ST. CLAIR	208	167
CONTRACT NO. 76022				

SHEET NO. 1 OF 10 SHEETS

FED. ROAD DIST. NO. 6 [ILLINOIS] FED. AID PROJECT

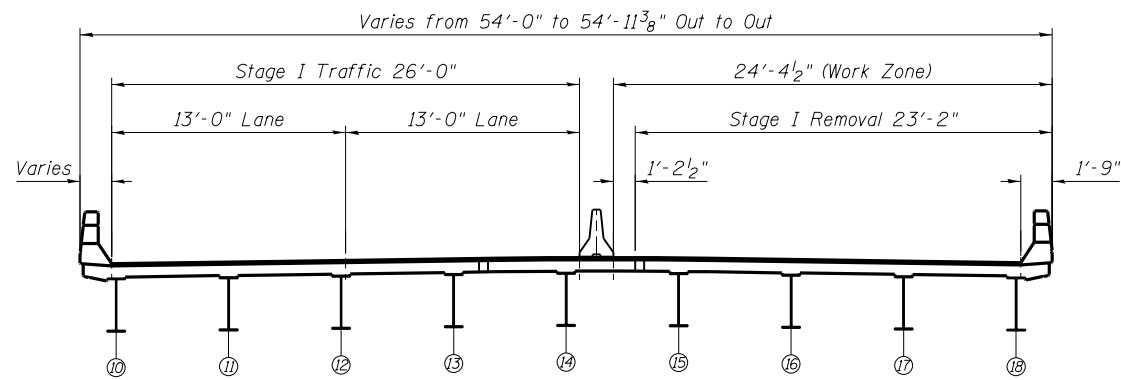

SN 082-0160 EASTBOUND CROSS SECTION
(Looking East)
STAGE I REMOVAL

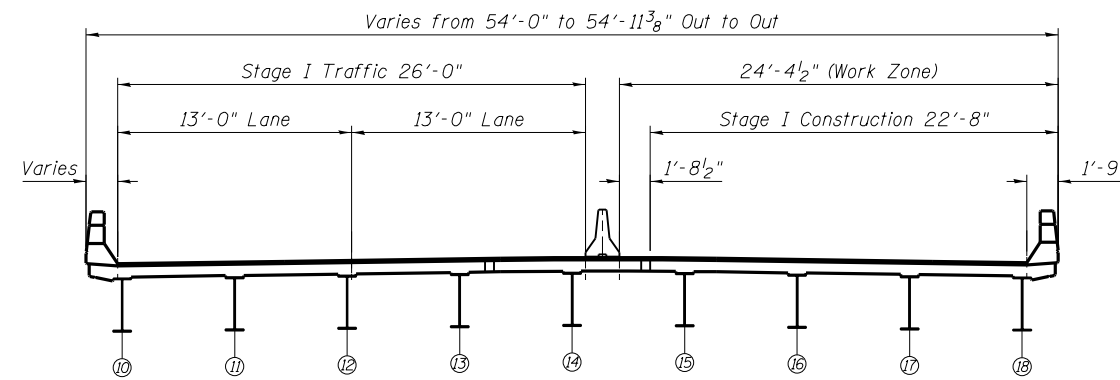

SN 082-0160 EASTBOUND CROSS SECTION
(Looking East)
STAGE I CONSTRUCTION

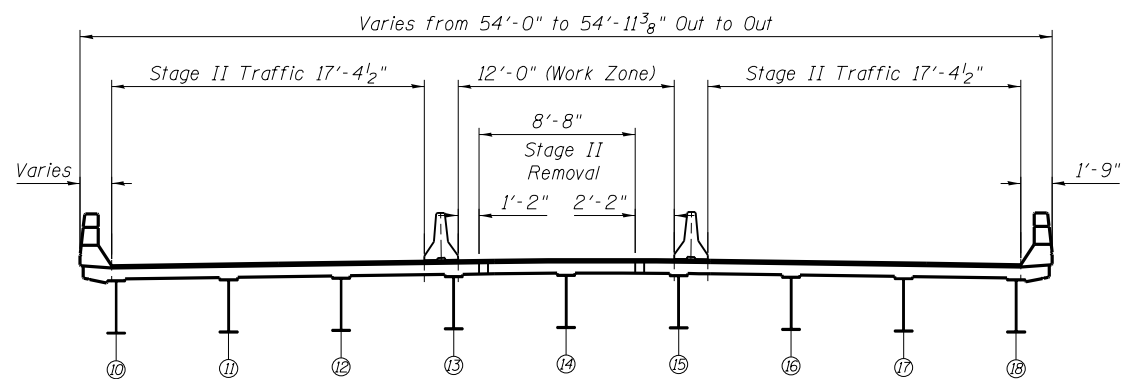

SN 082-0160 EASTBOUND CROSS SECTION
(Looking East)
STAGE II REMOVAL

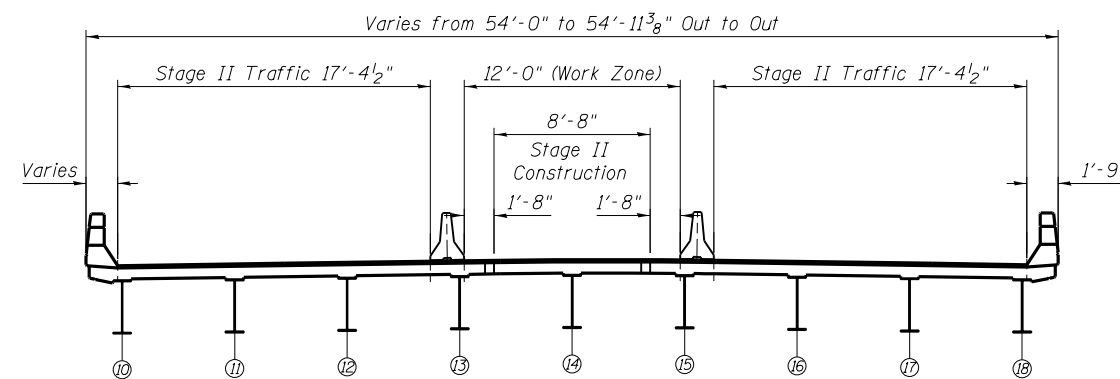

SN 082-0160 EASTBOUND CROSS SECTION
(Looking East)
STAGE II CONSTRUCTION

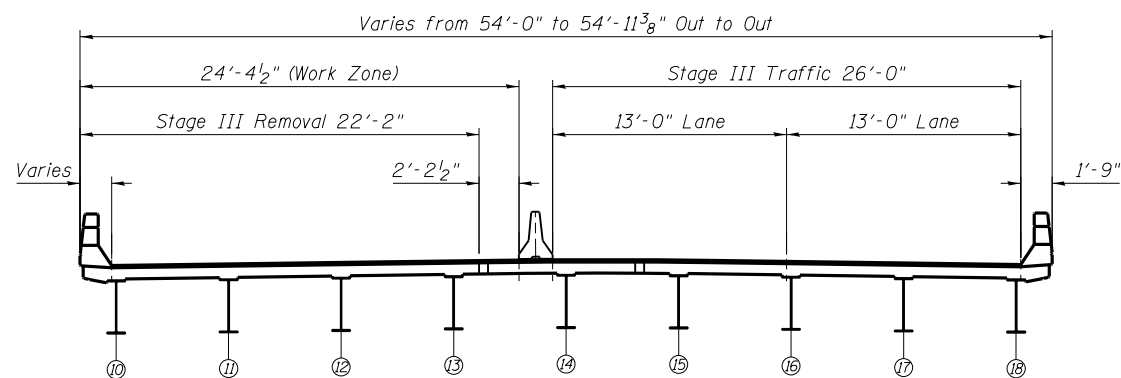

SN 082-0160 EASTBOUND CROSS SECTION
(Looking East)
STAGE III REMOVAL

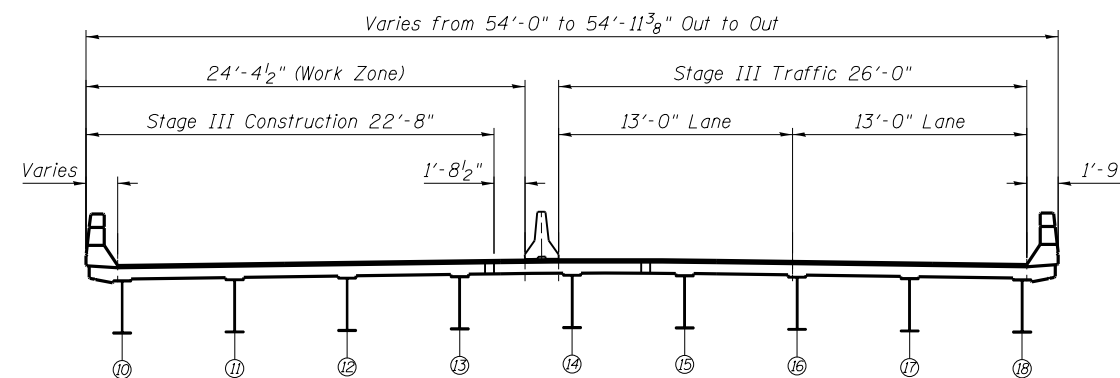

SN 082-0160 EASTBOUND CROSS SECTION
(Looking East)
STAGE III CONSTRUCTION

BENTON & ASSOCIATES, INC.

FILE NAME = P:\10e2166-2\Design\	USER NAME =	DESIGNED - MBH	REVISED -
Plans\082-0160 & 082-0161		CHECKED - SJH	REVISED -
0820160-76022-002-Staging.dgn	PLOT SCALE =	DRAWN - JAS	REVISED -
	PLOT DATE =	CHECKED - SJH	REVISED -

STATE OF ILLINOIS
DEPARTMENT OF TRANSPORTATION

STAGING SECTIONS
STRUCTURE NO. 082-0160

SHEET NO. 2 OF 10 SHEETS

F.A.I. RTE.	SECTION	COUNTY	TOTAL SHEETS	SHEET NO.
64	82-2HBI	ST. CLAIR	208	168
CONTRACT NO. 76022				
FED. ROAD DIST. NO. 8 ILLINOIS FED. AID PROJECT				

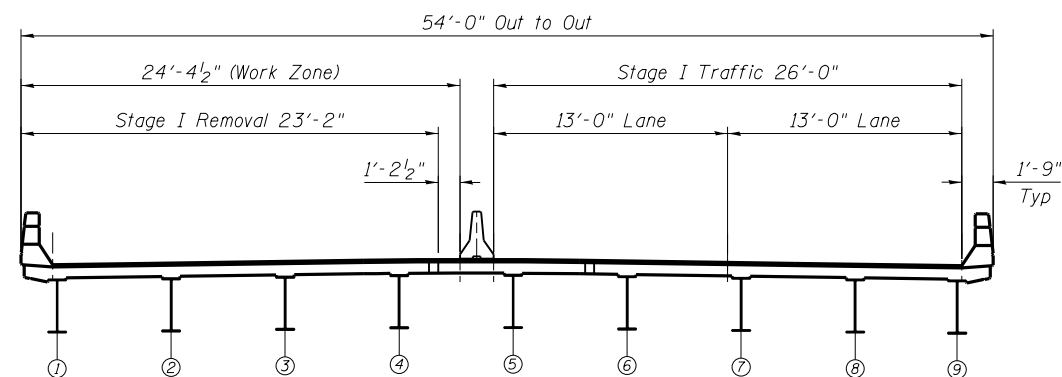

SN 082-0161 WESTBOUND CROSS SECTION
(Looking East)
STAGE I REMOVAL

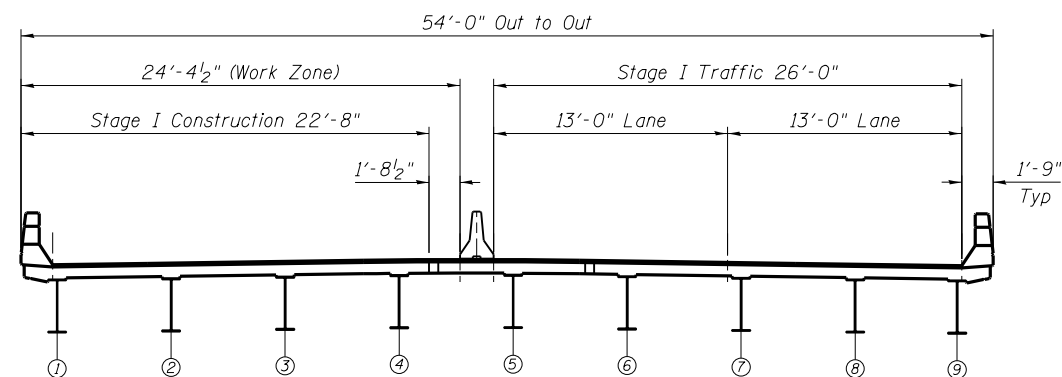

SN 082-0161 WESTBOUND CROSS SECTION
(Looking East)
STAGE I CONSTRUCTION

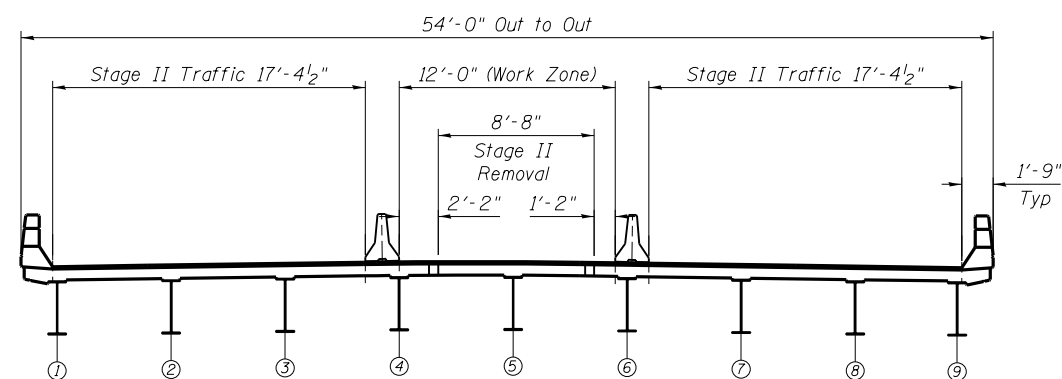

SN 082-0161 WESTBOUND CROSS SECTION
(Looking East)
STAGE II REMOVAL

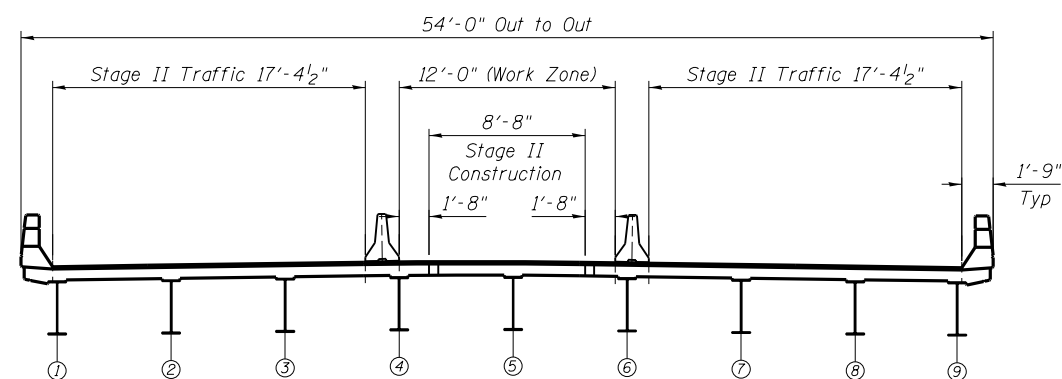

SN 082-0161 WESTBOUND CROSS SECTION
(Looking East)
STAGE II CONSTRUCTION

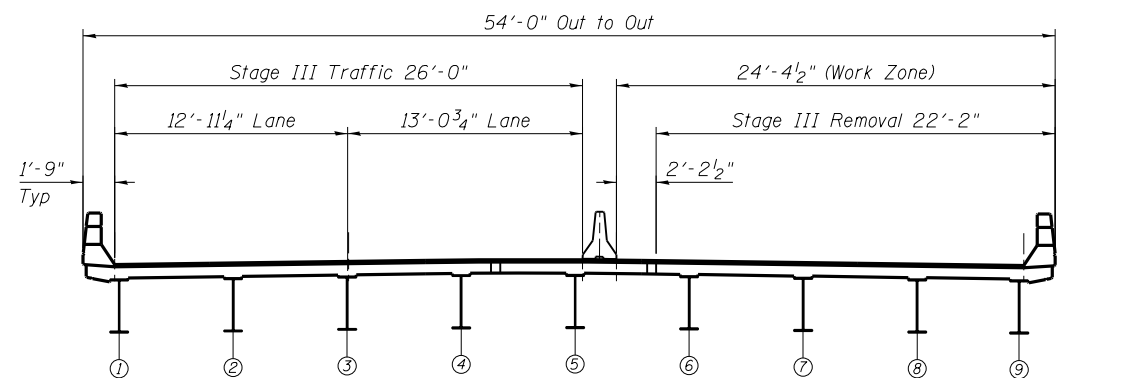

SN 082-0161 WESTBOUND CROSS SECTION
(Looking East)
STAGE III REMOVAL

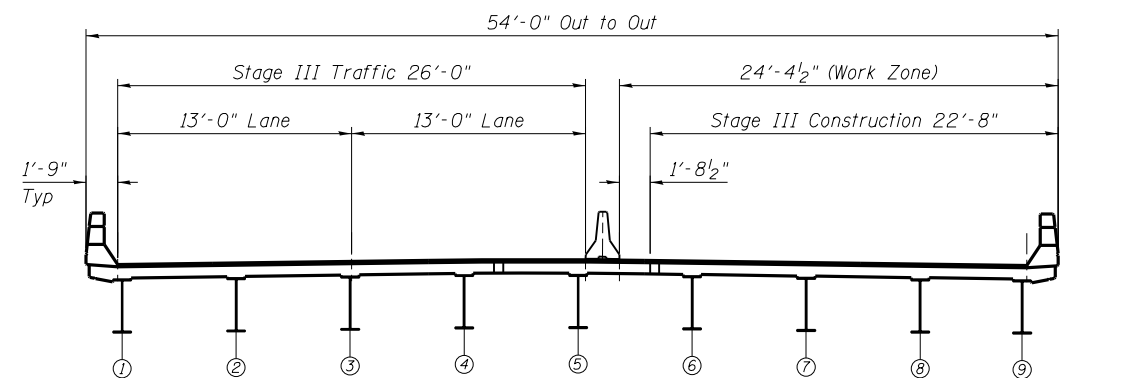

SN 082-0161 WESTBOUND CROSS SECTION
(Looking East)
STAGE III CONSTRUCTION

BENTON & ASSOCIATES, INC.

FILE NAME = P:\10e2166-2\Design\	USER NAME =	DESIGNED - MBH	REVISED -
Plans\082-0160 & 082-0161		CHECKED - SJH	REVISED -
0820160-76022-002-Staging.dgn	PLOT SCALE =	DRAWN - JAS	REVISED -
	PLOT DATE =	CHECKED - SJH	REVISED -

STATE OF ILLINOIS
DEPARTMENT OF TRANSPORTATION

STAGING SECTIONS
STRUCTURE NO. 082-0161

SHEET NO. 3 OF 10 SHEETS

F.A.I. RTE.	SECTION	COUNTY	TOTAL SHEETS	SHEET NO.
64	82-2HBI	ST. CLAIR	208	169
CONTRACT NO. 76022				
FED. ROAD DIST. NO. 8 ILLINOIS FED. AID PROJECT				

When "A" is 3'-6" or less, the temporary concrete barrier shall be anchored to the new slab according to Detail I or Detail II. No anchorage is required when "A" is greater than 3'-6".

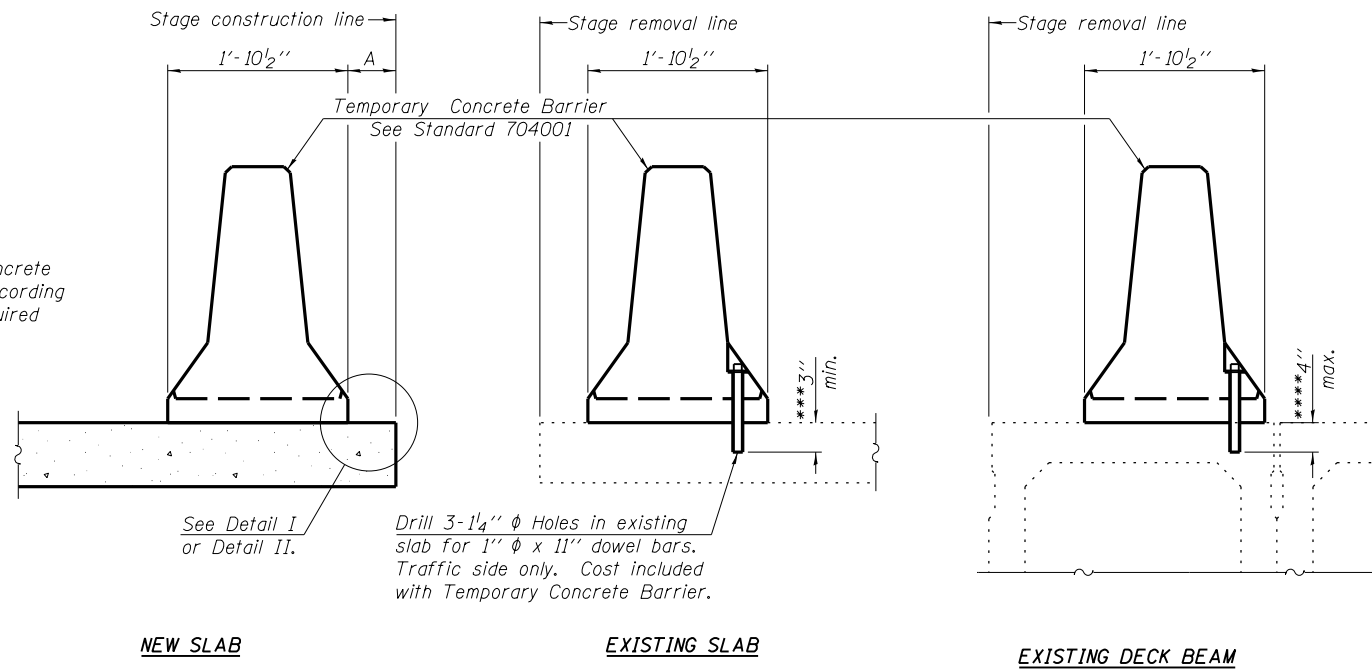

SECTIONS THRU SLAB OR DECK BEAM

NOTES

Detail I - With Bar Splicer or Couplers:
Connect one (1) 1" x 7" x "W" steel \bar{r} to the top layer of couplers with 2- $\frac{5}{8}$ " ϕ bolts screwed to coupler at approximate \bar{c} of each barrier panel.

Detail II - With Extended Reinforcement Bars:
Connect one (1) 1" x 7" x "W" steel \bar{r} to the concrete slab or concrete wearing surface with 2- $\frac{5}{8}$ " ϕ Expansion Anchors or cast in place inserts spaced between the top layer of reinforcement at approximate \bar{c} of each barrier panel.

Cost of anchorage is included with Temporary Concrete Barrier. The 1" x 7" x "W" plate shall not be removed until stage II construction forms and all reinforcement bars are in place and the concrete is ready to be placed.

*** Dimension shown is minimum required embedment into concrete. If hot-mix asphalt wearing surface is present, minimum embedment shall be in addition to wearing surface depth.

**** If existing deck beam is to remain in place after stage construction, embedment shall only be into wearing surface and not into existing deck beam concrete.

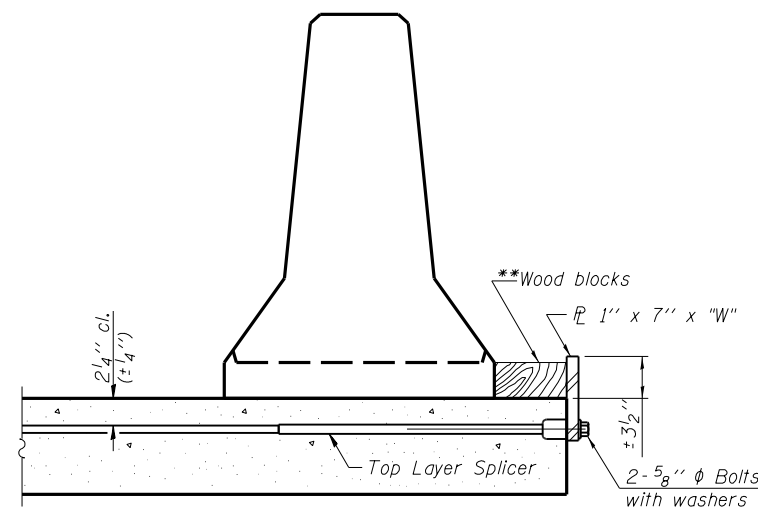

DETAIL I

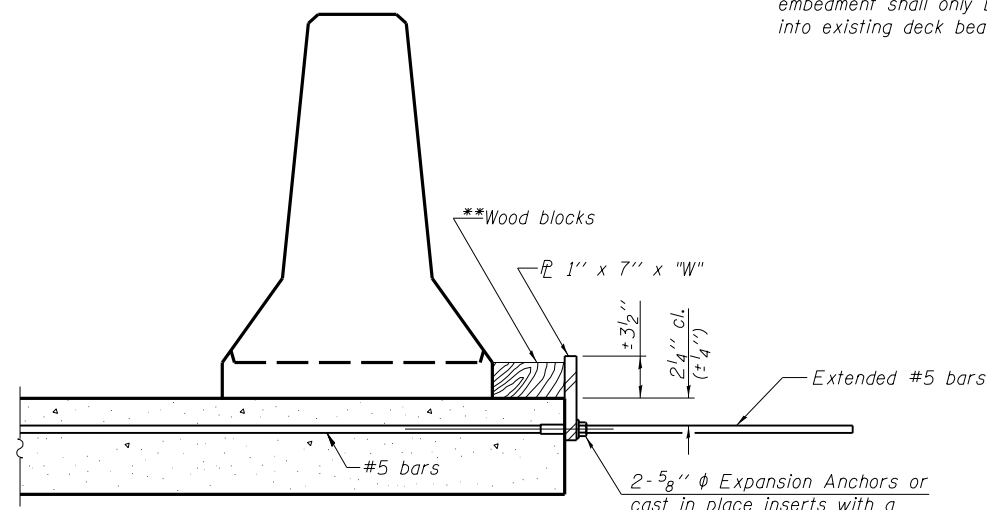

DETAIL II

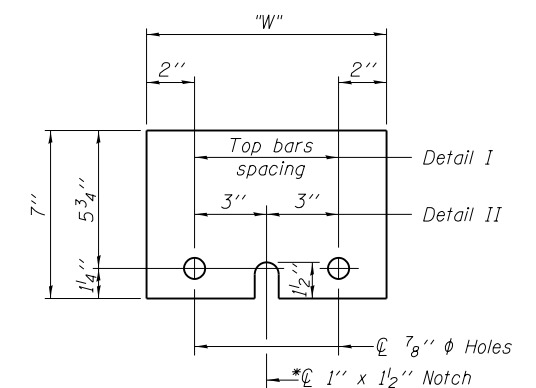

STEEL RETAINER \bar{r} 1" x 7" x "W"

* Required only with Detail II

** Wood blocks may be omitted when required to provide minimum stage traffic lane width. When the wood blocks are omitted, the concrete barrier shall be in direct contact with the steel retainer plate.

"W" = Top bars spacing + 4"

R-27 7-1-10
BENTON & ASSOCIATES, INC.

FILE NAME = P:\10e2166-2\ Design\ Plans\ 082-0160 & 082-0161	USER NAME =	DESIGNED - MBH	REVISED -
0820160-76022-003-Barrier.dgn	PLOT SCALE =	CHECKED - SJH	REVISED -
	PLOT DATE =	DRAWN - MBH	REVISED -
		CHECKED - SJH	REVISED -

STATE OF ILLINOIS
DEPARTMENT OF TRANSPORTATION

TEMPORARY CONCRETE BARRIER FOR STAGE CONSTRUCTION
STRUCTURE NO. 082-0160 & 082-0161

SHEET NO. 4 OF 10 SHEETS

F.A.I. RTE.	SECTION	COUNTY	TOTAL SHEETS	SHEET NO.
64	82-1HB1-2	ST. CLAIR	208	170
CONTRACT NO. 76022				
FED. ROAD DIST. NO. 8 ILLINOIS FED. AID PROJECT				

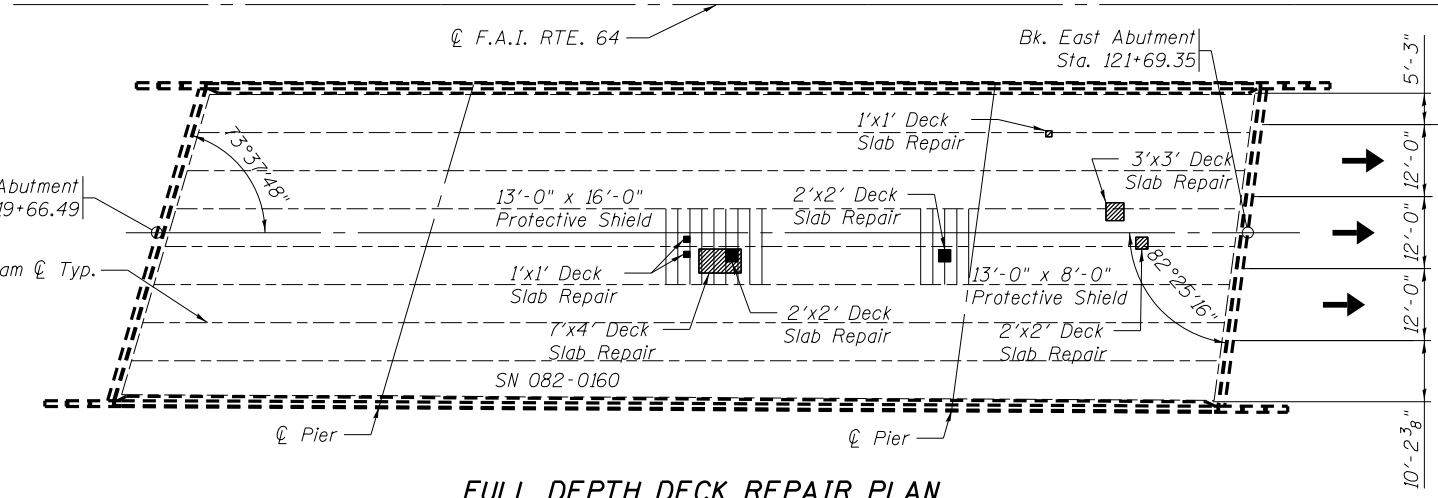
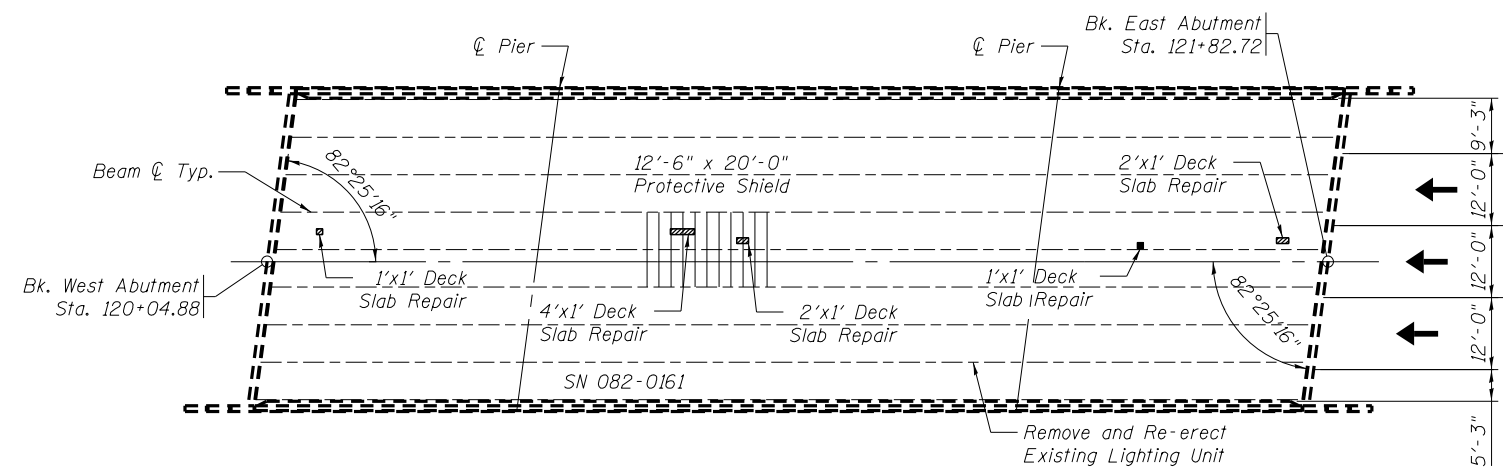

FULL DEPTH DECK REPAIR PLAN

LEGEND

- Area of Partial Depth Deck Repair
- Area of Full Depth Deck Repair

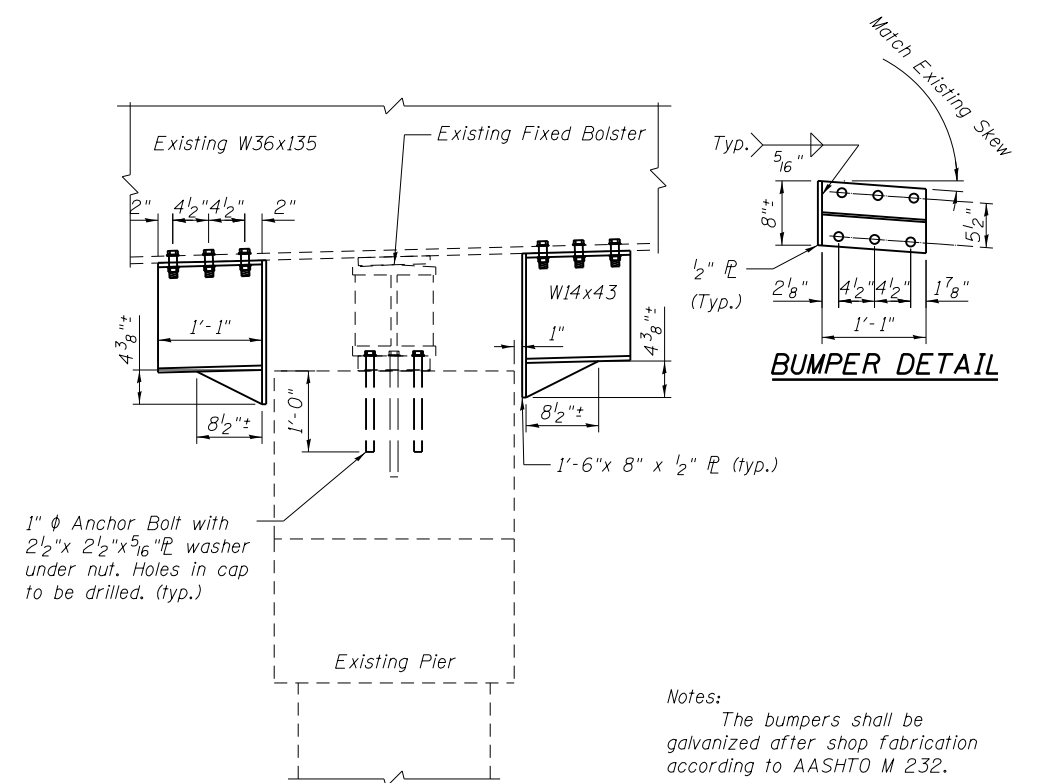

Notes:
The bumpers shall be galvanized after shop fabrication according to AASHTO M 232.

NEW BUMPERS
(At Existing Fixed Bearing Bolster on East Pier on both structures)

BILL OF MATERIAL

ITEM	UNIT	QUANTITY
Deck Slab Repair (Full)	Sq. Yd.	1.3
Deck Slab Repair (Partial)	Sq. Yd.	5.7
Furnishing and Erecting Structural Steel	Pound	2520
Remove and Re-erect Existing Lighting Unit	Each	1
Protective Shield	Sq. Yd.	6.3
Anchor Bolts, 1"	Each	72

BENTON & ASSOCIATES, INC.

FILE NAME = P:\10e2166-2\Design\	USER NAME =	DESIGNED - MBH	REVISED -
Plans\082-0160 & 082-0161		CHECKED - SJH	REVISED -
0820160-76022-004-Deck.dgn	PLOT SCALE =	DRAWN - JAS	REVISED -
	PLOT DATE =	CHECKED - SJH	REVISED -

**STATE OF ILLINOIS
DEPARTMENT OF TRANSPORTATION**

**DECK REPAIRS
STRUCTURE NO. 082-0160 & 082-0161**

SHEET NO. 5 OF 10 SHEETS

F.A.I. RTE.	SECTION	COUNTY	TOTAL SHEETS	SHEET NO.
64	82-2HBI	ST. CLAIR	208	171
CONTRACT NO. 76022				
FED. ROAD DIST. NO. 8 ILLINOIS FED. AID PROJECT				

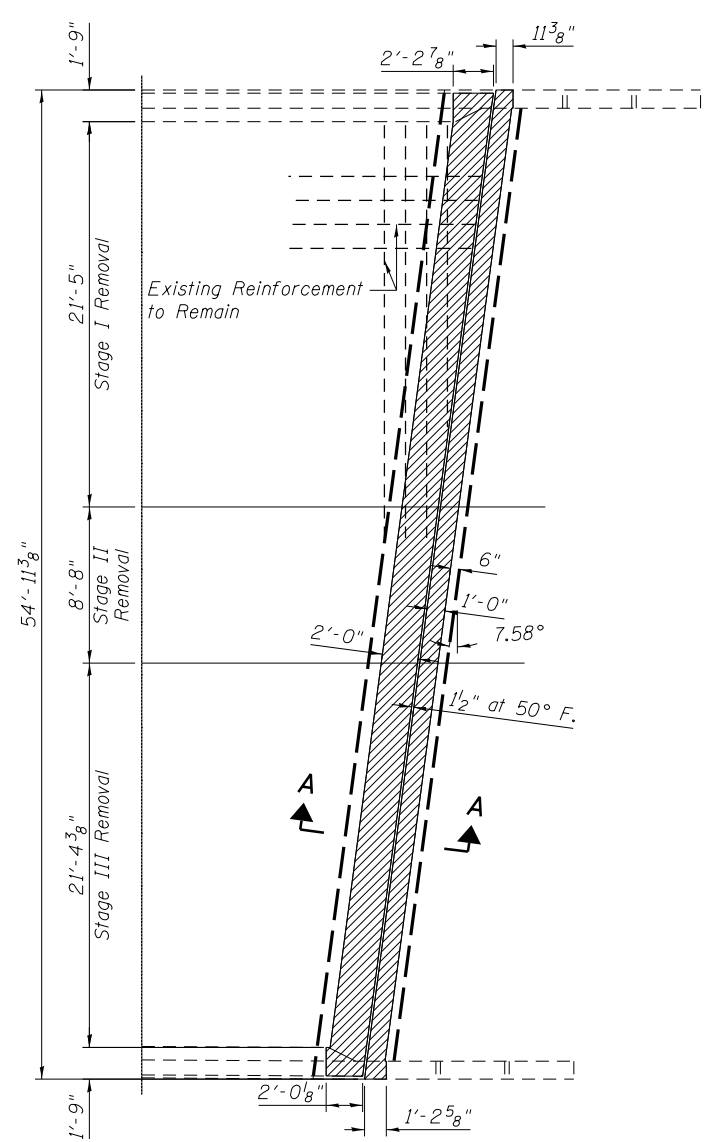

CONCRETE REMOVAL
(East Abut. shown)

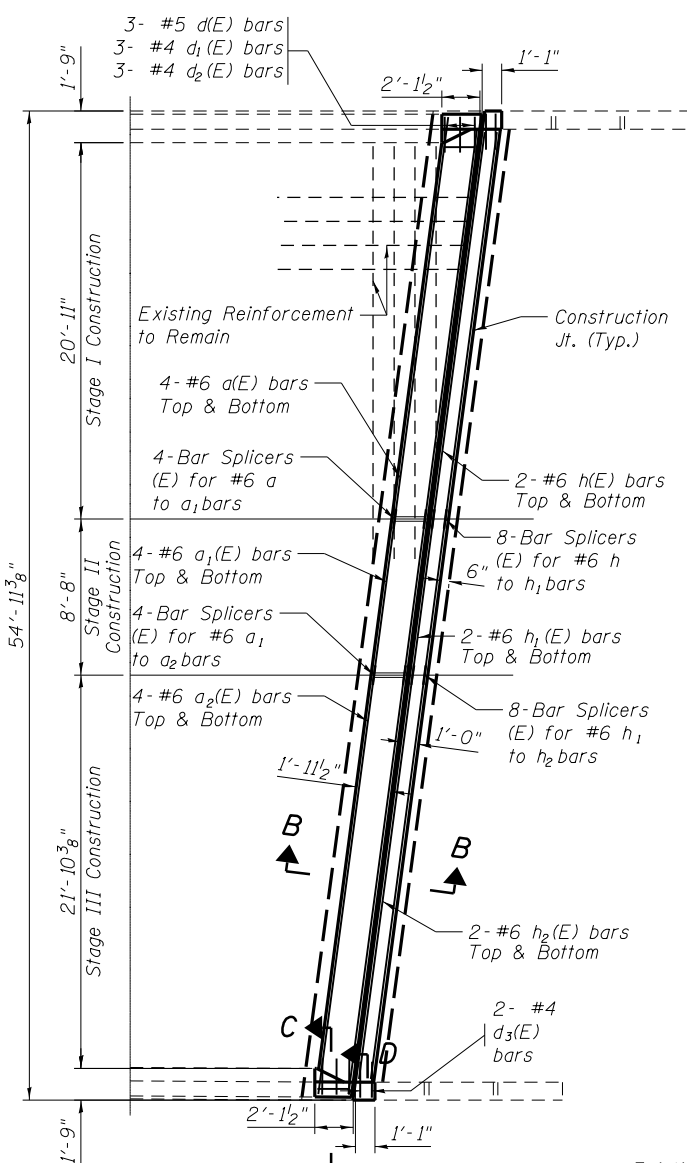

CONCRETE REPLACEMENT
(East Abut. shown)

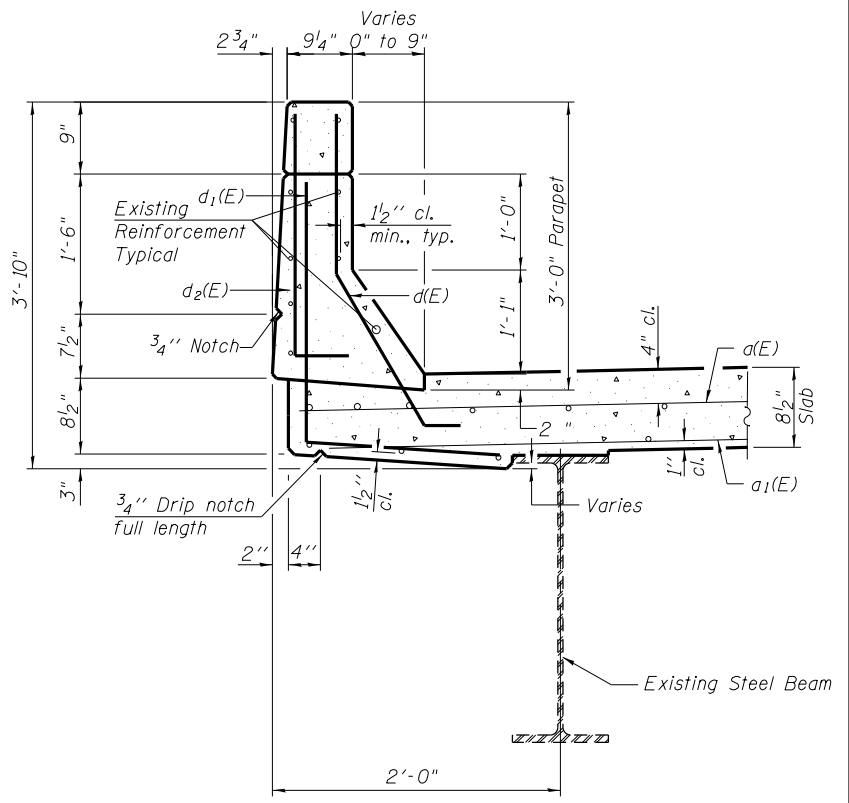

SECTION C-C

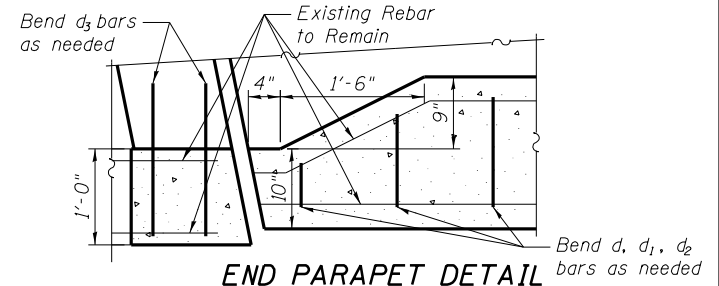

END PARAPET DETAIL

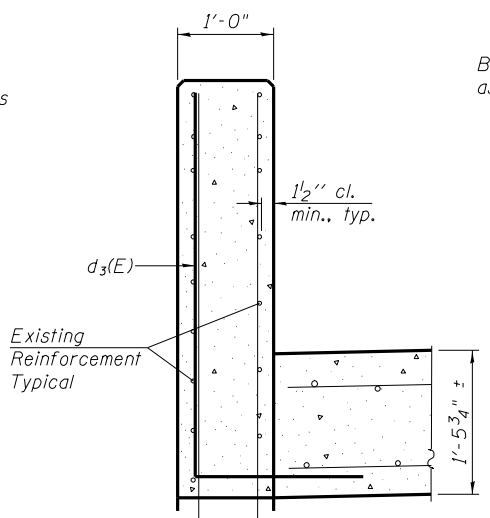

SECTION D-D

SUPERSTRUCTURE BILL OF MATERIAL

Bar	No.	Size	Length	Shape
a(E)	8	#6	22'-4"	—
a1(E)	8	#6	8'-8"	—
a2(E)	8	#6	23'-3"	—
d(E)	6	#5	4'-4"	┘
d1(E)	6	#4	3'-7"	┘
d2(E)	6	#4	3'-3"	┘
d3(E)	4	#4	5'-9"	┘
h(E)	4	#6	21'-10"	—
h1(E)	4	#6	8'-8"	—
h2(E)	4	#6	22'-9"	—
Bar Splicers			Each	24
Reinforcement Bars, Epoxy Coated			Pound	1050
Concrete Superstructure			Cu. Yds.	7.2
Concrete Removal			Cu. Yds.	7.3
Performed Strip Seal			Foot	56

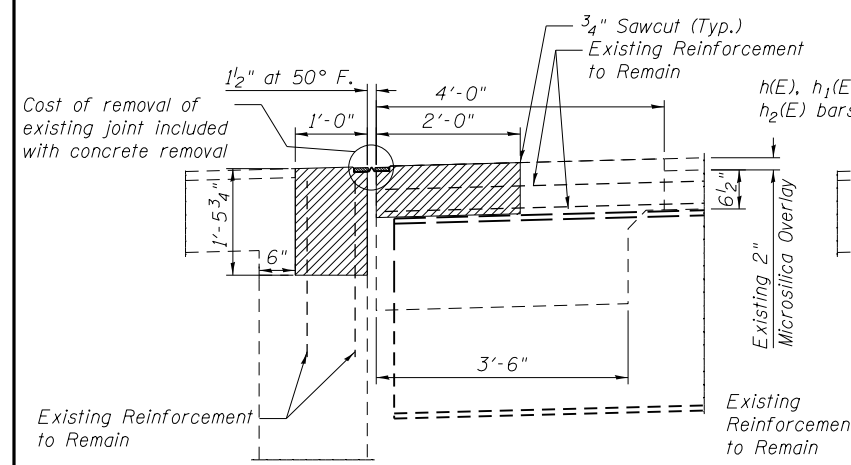

SECTION A-A

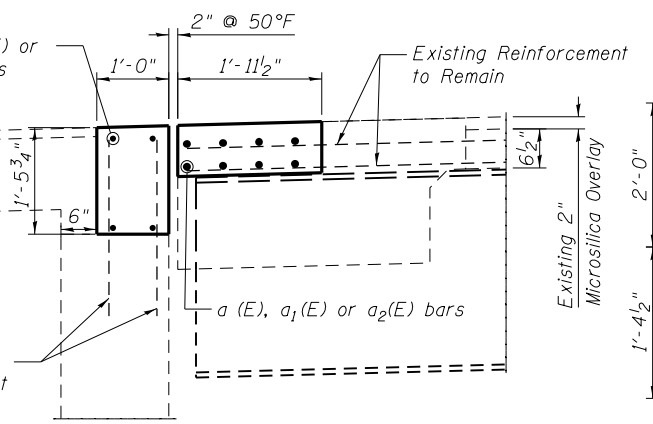

SECTION B-B

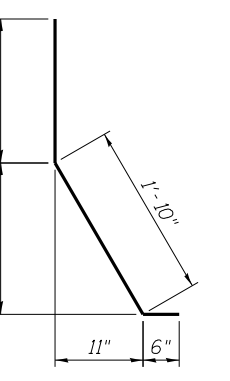

BAR d(E)

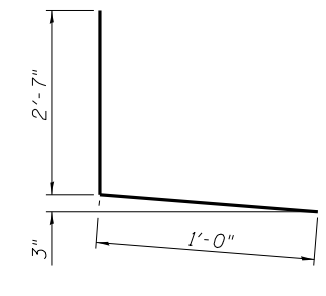

BAR d1(E)

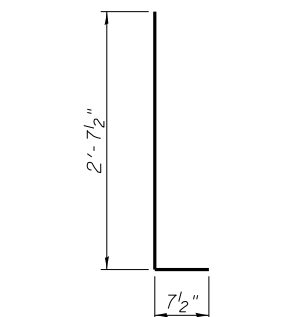

BAR d2(E)

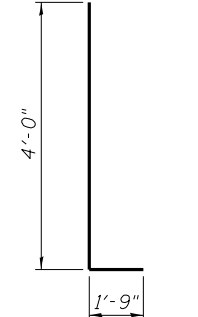

BAR d3(E)

BENTON & ASSOCIATES, INC.

FILE NAME = P:\10e2166-2\ Design\	USER NAME =	DESIGNED - MBH	REVISED - 10/3/13
Plans\ 082-0160 & 082-0161		CHECKED - SJH	REVISED -
0820160-76022-005-Joint.dgn	PLOT SCALE =	DRAWN - MBH	REVISED -
	PLOT DATE	CHECKED - SJH	REVISED -

**STATE OF ILLINOIS
DEPARTMENT OF TRANSPORTATION**

**CONCRETE REMOVAL & REPLACEMENT
STRUCTURE NO. 082-0160**

SHEET NO. 6 OF 10 SHEETS

F.A.I. RTE.	SECTION	COUNTY	TOTAL SHEETS	SHEET NO.
64	82-2HBI	ST. CLAIR	208	172
CONTRACT NO. 76022				
FED. ROAD DIST. NO. 8 ILLINOIS FED. AID PROJECT				

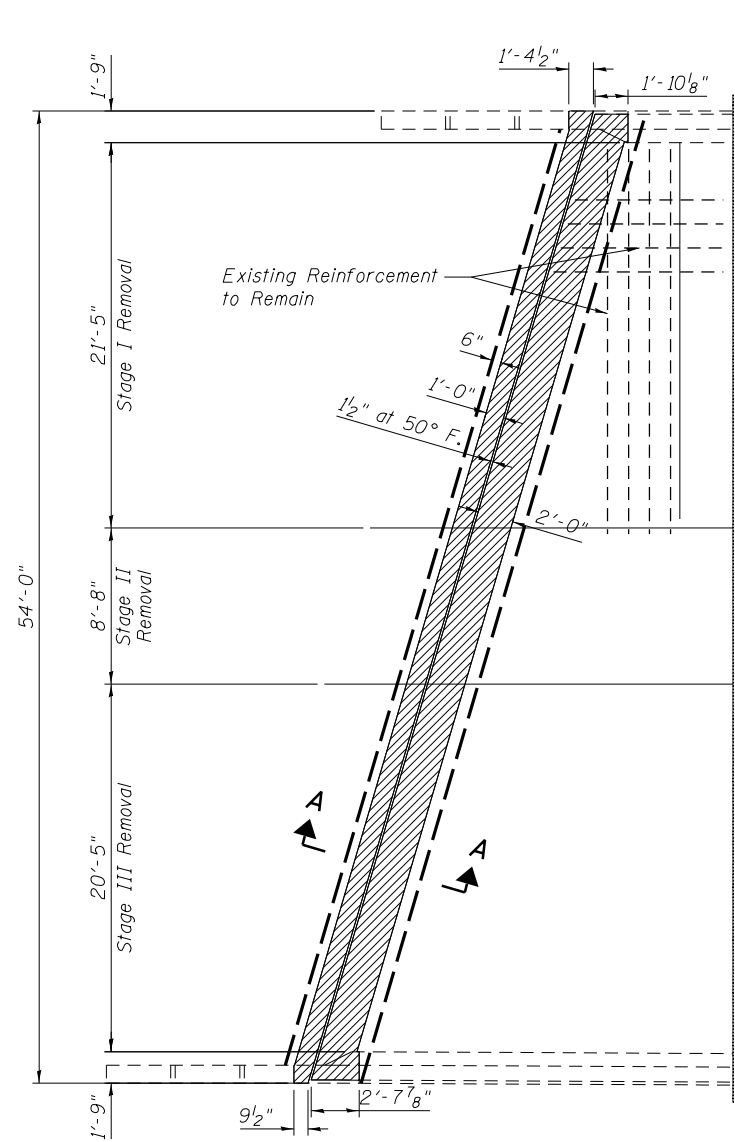

CONCRETE REMOVAL
(West Abut. shown)

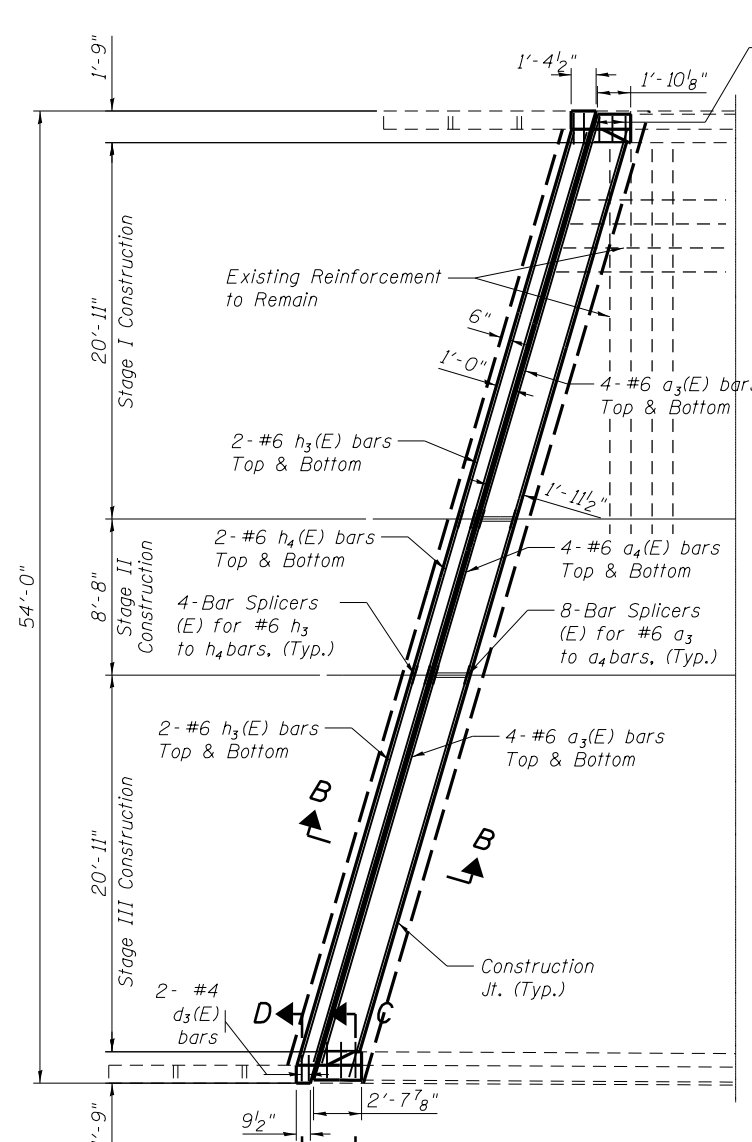

CONCRETE REPLACEMENT
(West Abut. shown)

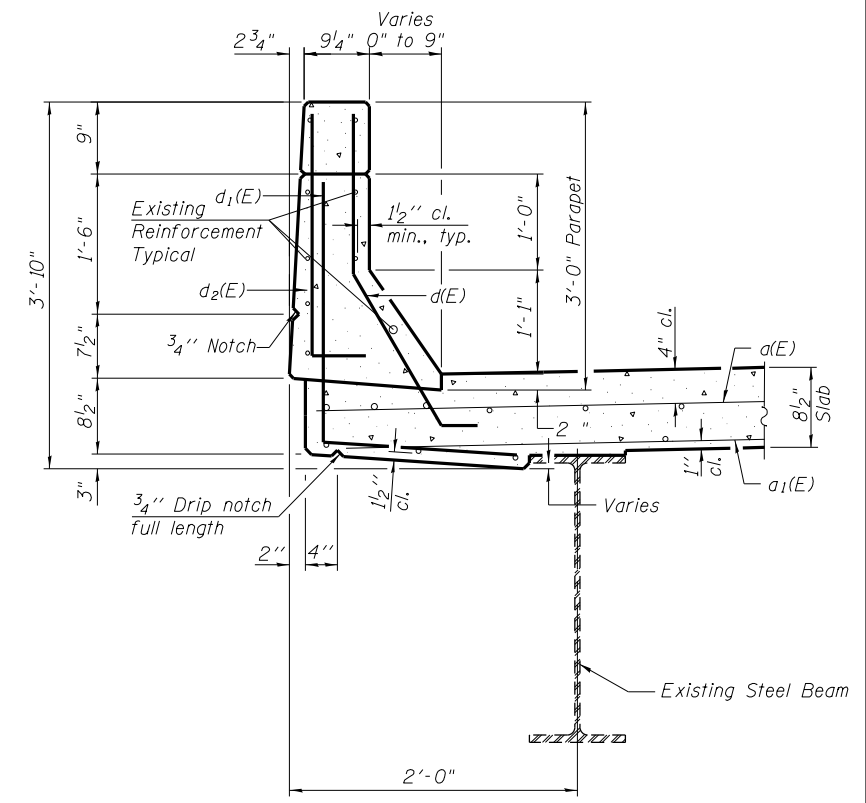

SECTION C-C

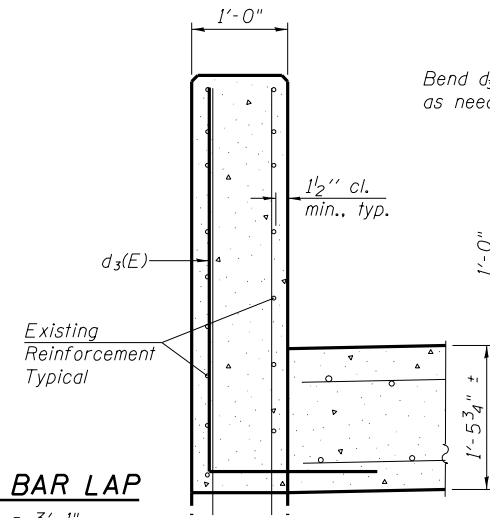

SECTION D-D

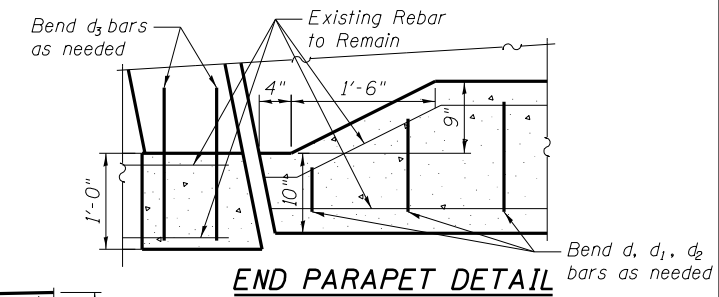

END PARAPET DETAIL

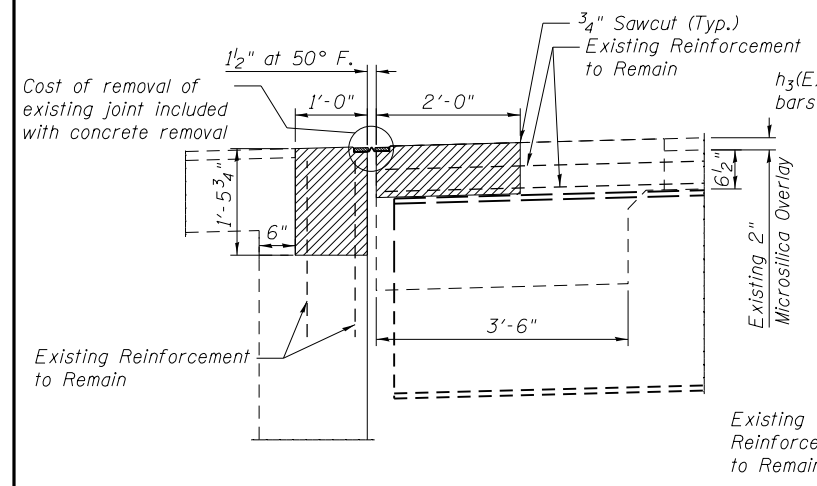

SECTION A-A

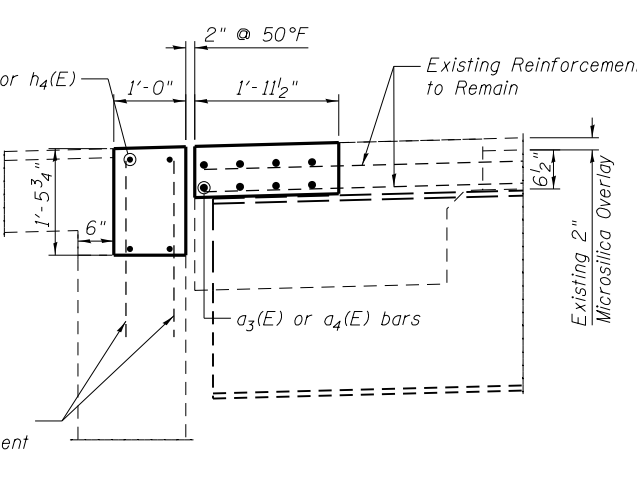

SECTION B-B

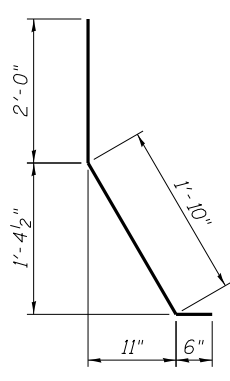

BAR d(E)

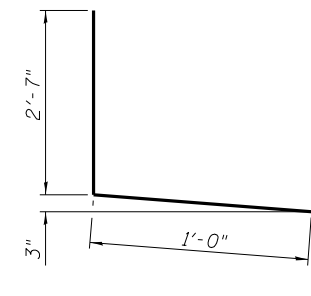

BAR d1(E)

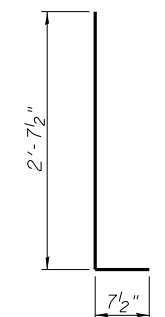

BAR d2(E)

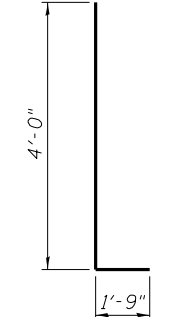

BAR d3(E)

MINIMUM BAR LAP
#6 bar = 3'-1"

SUPERSTRUCTURE BILL OF MATERIAL

Bar	No.	Size	Length	Shape
a3(E)	16	#6	23'-1"	—
a4(E)	8	#6	9'-0"	—
d(E)	6	#5	4'-4"	L
d1(E)	6	#4	3'-7"	L
d2(E)	6	#4	3'-3"	L
d3(E)	4	#4	5'-9"	L
h3(E)	8	#6	22'-6"	—
h4(E)	4	#6	9'-0"	—
Bar Splicers	Each		24	
Reinforcement Bars, Epoxy Coated	Pound		1060	
Concrete Superstructure	Cu. Yds.		7.3	
Concrete Removal	Cu. Yds.		7.4	
Performed Strip Seal	Foot		56	

Bars indicated thus 4x2 - #6 etc. indicates 4 lines of bars with 2 lengths per line.

BENTON & ASSOCIATES, INC.

FILE NAME = P:\10e2166-2\ Design\ Plans\ 082-0160 & 082-0161	USER NAME =	DESIGNED - MBH	REVISED - 10/3/13
0820160-76022-006-Joint.dgn	PLOT SCALE =	CHECKED - SJH	REVISED -
	PLOT DATE	DRAWN - MBH	REVISED -
		CHECKED - SJH	REVISED -

STATE OF ILLINOIS DEPARTMENT OF TRANSPORTATION

CONCRETE REMOVAL & REPLACEMENT STRUCTURE NO. 082-0160

SHEET NO. 7 OF 10 SHEETS

F.A.I. RTE.	SECTION	COUNTY	TOTAL SHEETS	SHEET NO.
64	82-2HBI	ST. CLAIR	208	173
CONTRACT NO. 76022				
FED. ROAD DIST. NO. 8 ILLINOIS FED. AID PROJECT				

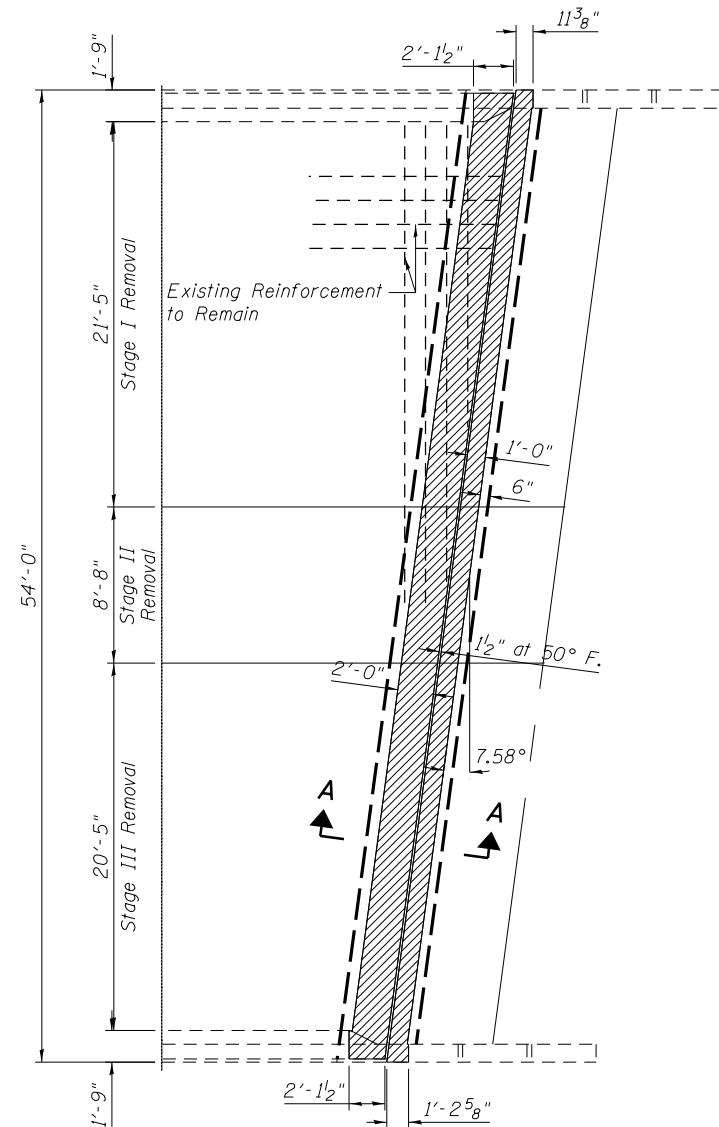

CONCRETE REMOVAL

(East Abut. shown)
(West Abut. similar)

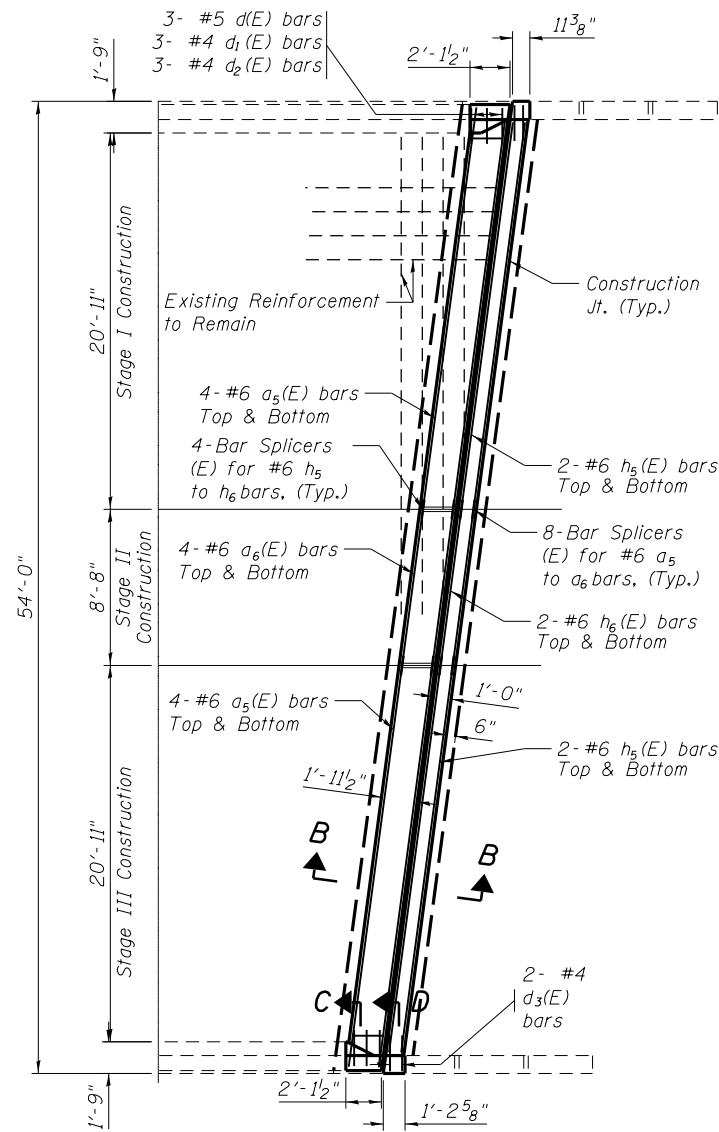

CONCRETE REPLACEMENT

(East Abut. shown)
(West Abut. similar)

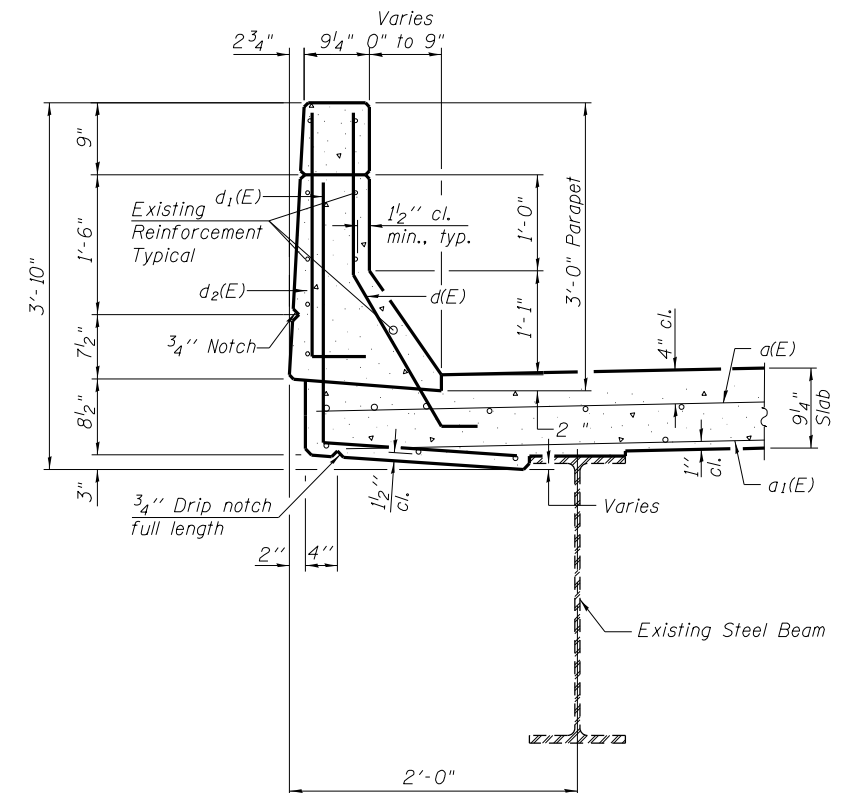

SECTION C-C

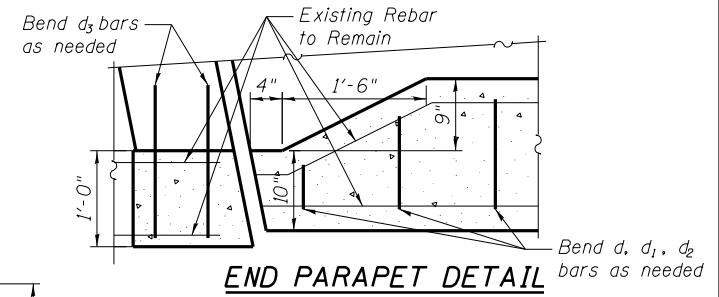

END PARAPET DETAIL

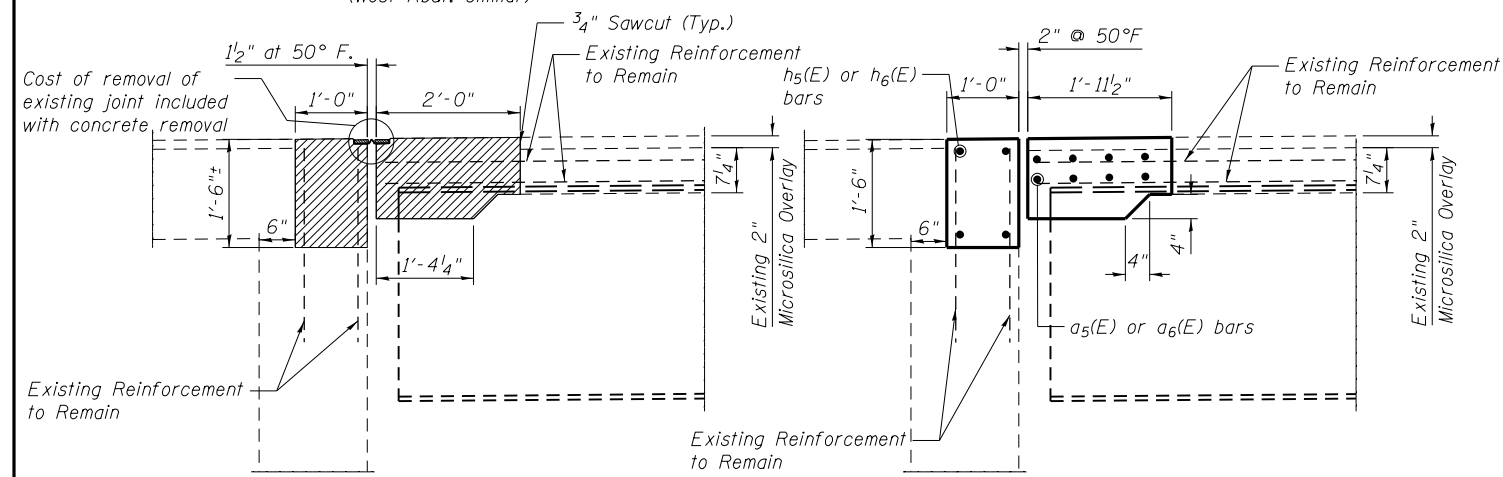

SECTION A-A

SECTION B-B

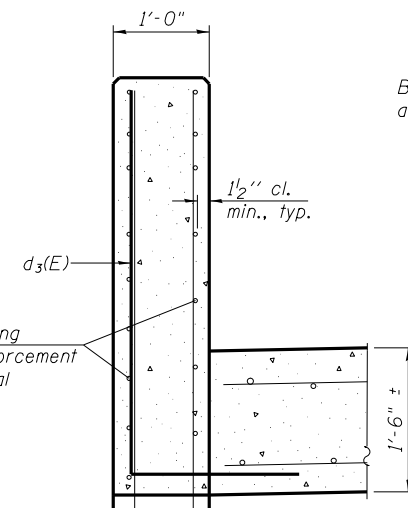

SECTION D-D

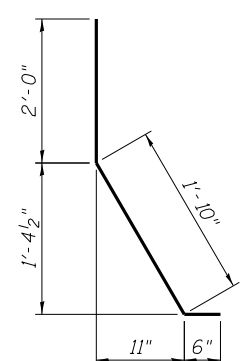

BAR d(E)

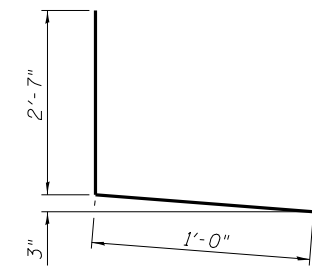

BAR d1(E)

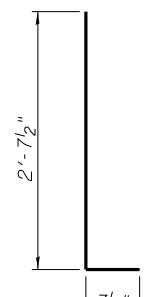

BAR d2(E)

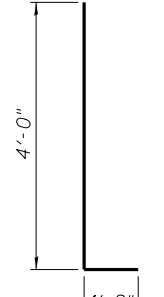

BAR d3(E)

SUPERSTRUCTURE BILL OF MATERIAL

Bar	No.	Size	Length	Shape
a5(E)	32	#6	22'-4"	—
a6(E)	16	#6	8'-8"	—
d(E)	12	#5	4'-4"	┘
d1(E)	12	#4	3'-7"	┘
d2(E)	12	#4	3'-3"	┘
d3(E)	8	#4	5'-9"	┘
h5(E)	16	#6	21'-10"	—
h6(E)	8	#6	8'-8"	—
Bar Splicers			Each	48
Reinforcement Bars, Epoxy Coated			Pound	2060
Concrete Superstructure			Cu. Yds.	14.1
Concrete Removal			Cu. Yds.	14.3
Performed Strip Seal			Foot	109

BENTON & ASSOCIATES, INC.

FILE NAME = P:\10e2166-2\ Design\ Plans\ 082-0160 & 082-0161	USER NAME =	DESIGNED - MBH	REVISED - 10/3/13
0820160-76022-007-Joint.dgn	PLOT SCALE =	CHECKED - SJH	REVISED -
	PLOT DATE	DRAWN - MBH	REVISED -
		CHECKED - SJH	REVISED -

**STATE OF ILLINOIS
DEPARTMENT OF TRANSPORTATION**

**CONCRETE REMOVAL & REPLACEMENT
STRUCTURE NO. 082-0161**

SHEET NO. 8 OF 10 SHEETS

F.A.I. RTE.	SECTION	COUNTY	TOTAL SHEETS	SHEET NO.
64	82-2HBI	ST. CLAIR	208	174
CONTRACT NO. 76022				
FED. ROAD DIST. NO. 8 ILLINOIS FED. AID PROJECT				

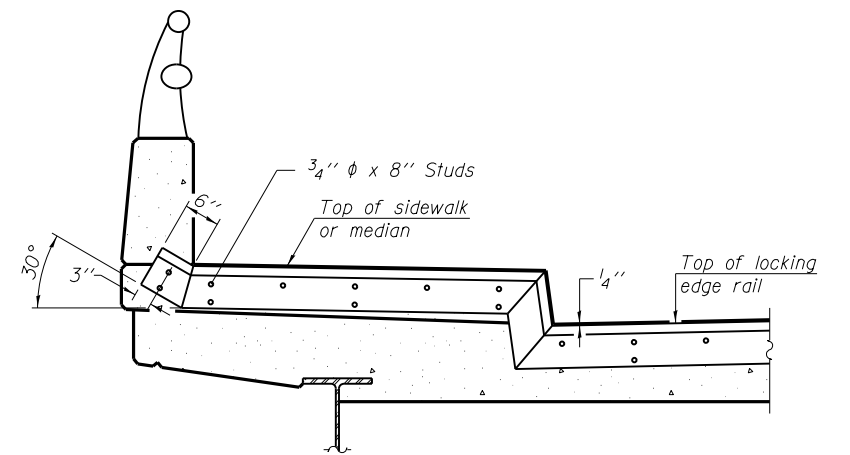
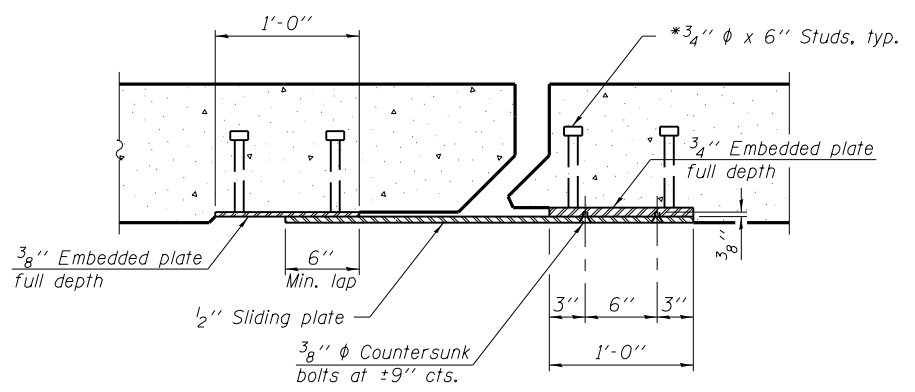
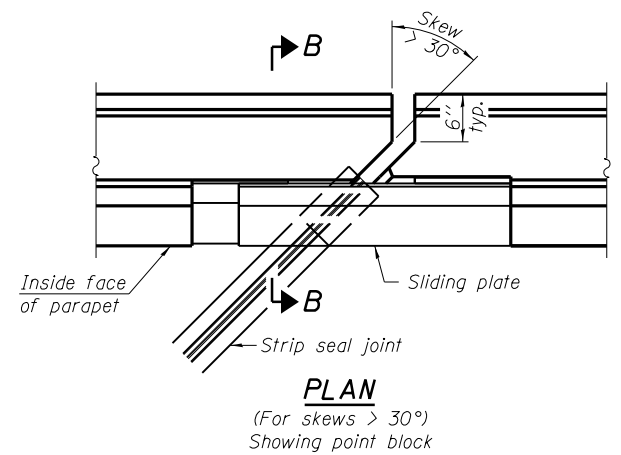
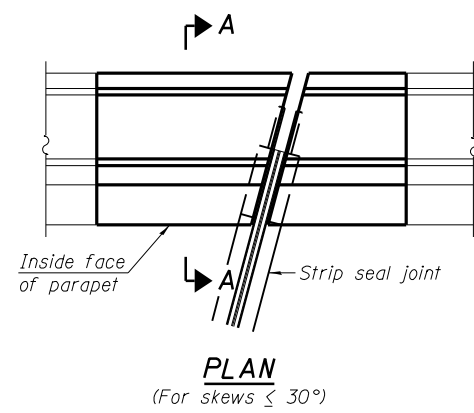

TYPICAL END TREATMENT AT SIDEWALK OR MEDIAN

Shorter plates with a single row of studs at 12" cts. may be necessary on medians which are shallower than 9". See manufacturer's recommendation.

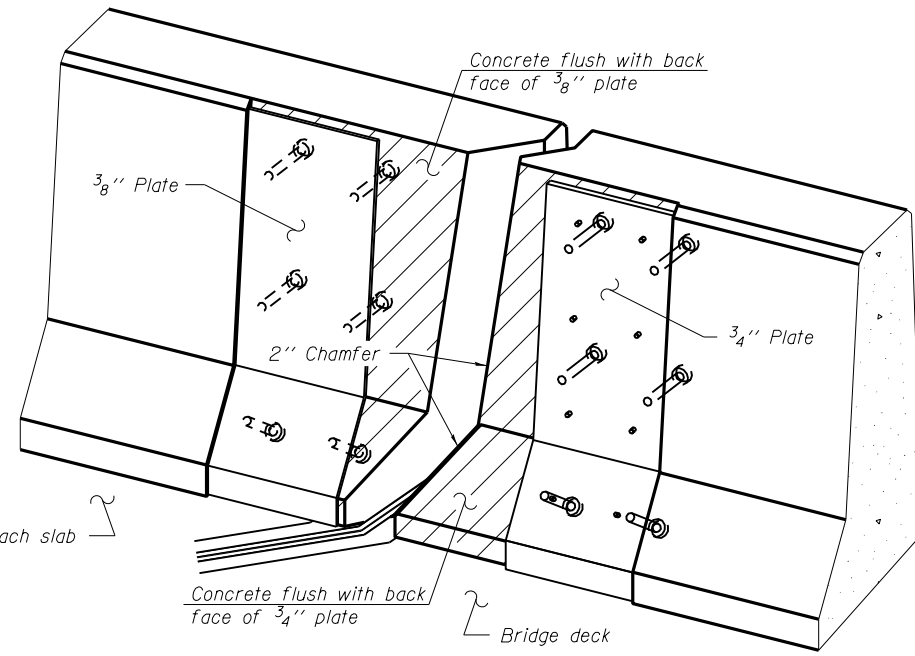
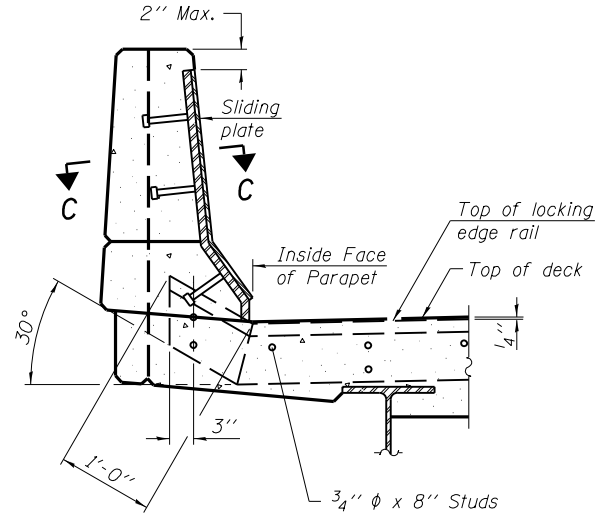
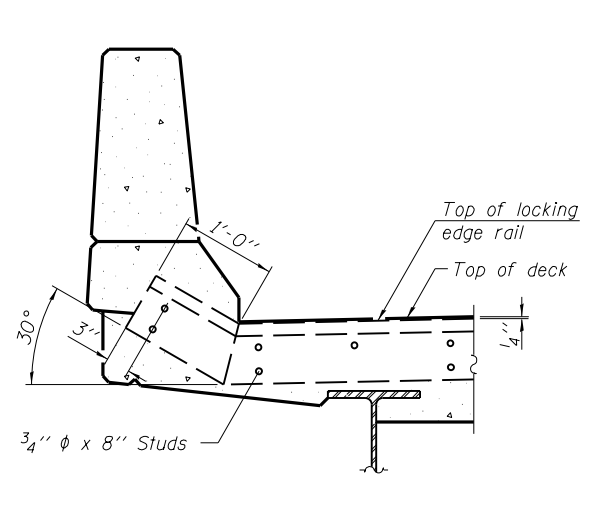

Notes:

The strip seal shall be made continuous and shall have a minimum thickness of 1/4". The configuration of the strip seal shall match the configuration of the Locking Edge Rails. Open or "webbed" strip seal gland configurations are not permitted. The gland shall be sized for a maximum rated movement of 4 inches.

The Locking Edge Rails depicted are conceptual only, except for the minimum dimensions shown. The actual configuration of the Locking Edge Rails and matching strip seal may vary from manufacturer to manufacturer. Flanged edge rails will not be allowed. Locking Edge Rails may be spliced at slope discontinuities.

The manufacturer's recommended installation methods shall be followed.

The joint opening and deck dimensions detailed on the superstructure are based on a rolled rail expansion joint. If the Contractor elects to use the welded rail expansion joint, the opening and deck dimensions shall be modified according to the dimensions detailed on this sheet. Required modifications shall be made at no additional cost to the State.

All steel components shall be galvanized after fabrication according to Article 520.03 of the Standard Specifications.

Maximum space between rail segments at stage lines shall be 3/16", sealed with a suitable sealant.

Parapet plates and anchorage studs for skews $> 30^\circ$ included in the cost of Preformed Joint Strip Seal.

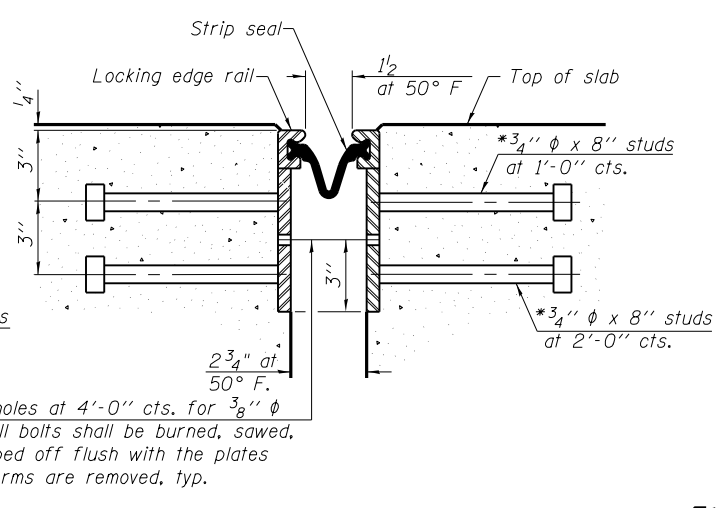
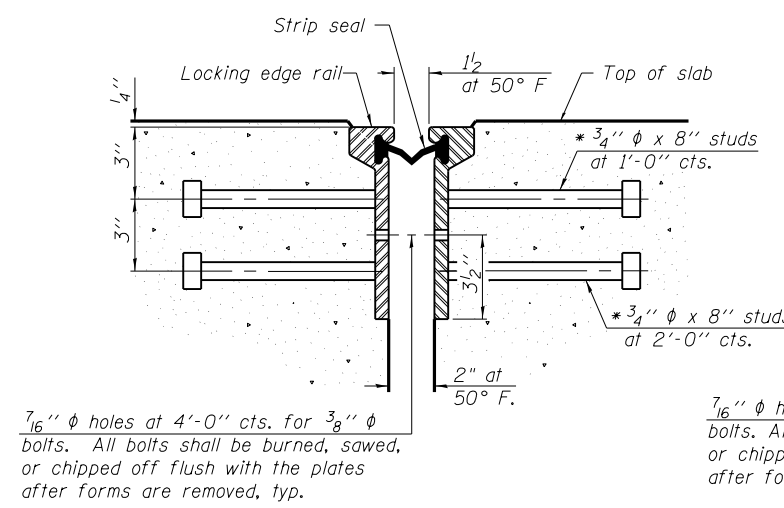

ROLLED EXTRUDED RAIL

WELDED RAIL

LOCKING EDGE RAIL SPLICE

The inside of the locking edge rail groove shall be free of weld residue.
Rolled rail shown, welded rail similar.

EJ-SSJ
BENTON & ASSOCIATES, INC.

7-1-10

* Granular or solid flux filled headed studs conforming to Article 1006.32 of the Std. Specs., automatically end welded.

LOCKING EDGE RAILS

BILL OF MATERIAL

Item	Unit	Total
Preformed Joint Strip Seal	Foot	221

FILE NAME = P:\10e2166-2\ Design\ Plans\ 082-0160 & 082-0161	USER NAME =	DESIGNED - MBH	REVISED -
0820160-76022-008-Joint.dgn	PLOT SCALE =	CHECKED - SJH	REVISED -
	PLOT DATE	DRAWN - JAS	REVISED -
		CHECKED - SJH	REVISED -

STATE OF ILLINOIS
DEPARTMENT OF TRANSPORTATION

PREFORMED JOINT STRIP SEAL
STRUCTURE NO. 082-0160 & 082-0161

SHEET NO. 9 OF 10 SHEETS

F.A.I. RTE.	SECTION	COUNTY	TOTAL SHEETS	SHEET NO.
64	82-2HBI	ST. CLAIR	208	175
CONTRACT NO. 76022				
FED. ROAD DIST. NO. 8 ILLINOIS FED. AID PROJECT				

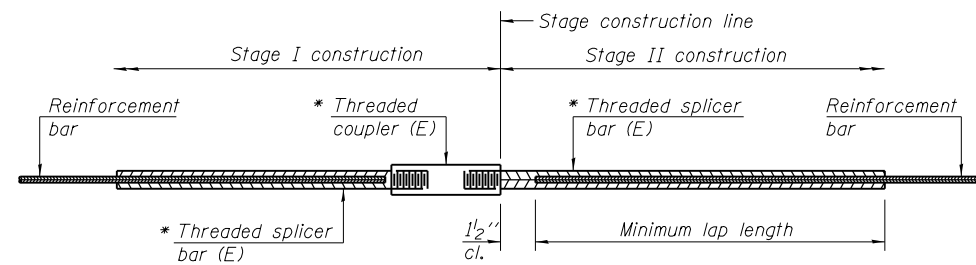

STANDARD BAR SPLICER ASSEMBLY

Minimum Lap Lengths					
Bar size to be spliced	Table 1	Table 2	Table 3	Table 4	Table 5
3, 4	1'-5"	1'-11"	2'-1"	2'-4"	2'-3"
5	1'-9"	2'-5"	2'-7"	2'-11"	2'-10"
6	2'-1"	2'-11"	3'-1"	3'-6"	3'-4"
7	2'-9"	3'-10"	4'-2"	4'-8"	4'-6"
8	3'-8"	5'-1"	5'-5"	6'-2"	5'-10"
9	4'-7"	6'-5"	6'-10"	7'-9"	7'-5"

- Table 1: Black bar, 0.8 Class C
- Table 2: Black bar, Top bar lap, 0.8 Class C
- Table 3: Epoxy bar, 0.8 Class C
- Table 4: Epoxy bar, Top bar lap, 0.8 Class C
- Table 5: Epoxy bar, Top bar lap, Class B

Threaded splicer bar length = min. lap length + 1/2" + thread length

* Epoxy not required on Bar Splicer Assembly components used in conjunction with black bars.

Location	Bar size	No. assemblies required	Table for minimum lap length
SN 082-0160 Deck	#6	8	Table 3
SN 082-0160 Hatch	#6	4	Table 3
SN 082-0160 Deck	#6	8	Table 3
SN 082-0160 Hatch	#6	4	Table 3
SN 082-0160 Deck	#6	16	Table 3
SN 082-0160 Hatch	#6	8	Table 3
SN 082-0161 Deck	#6	32	Table 3
SN 082-0161 Hatch	#6	16	Table 3

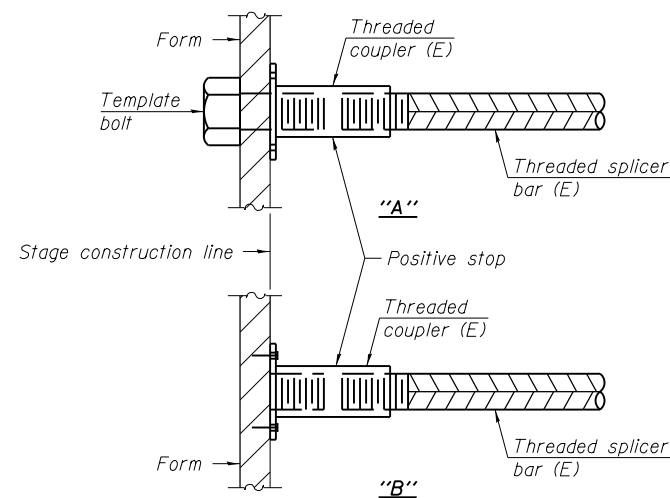

INSTALLATION AND SETTING METHODS

"A" : Set bar splicer assembly by means of a template bolt.
 "B" : Set bar splicer assembly by nailing to wood forms or cementing to steel forms.
 (E) : Indicates epoxy coating.

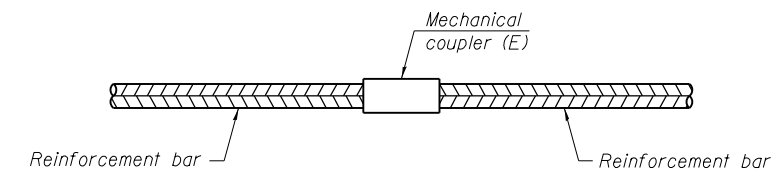

STANDARD MECHANICAL SPLICER

Location	Bar size	No. assemblies required

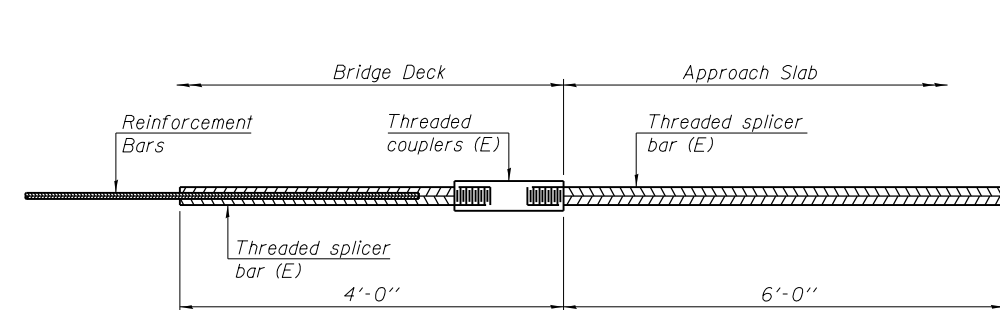

BAR SPLICER ASSEMBLY FOR #5 BAR ON INTEGRAL OR SEMI-INTEGRAL ABUTMENTS

No. required =

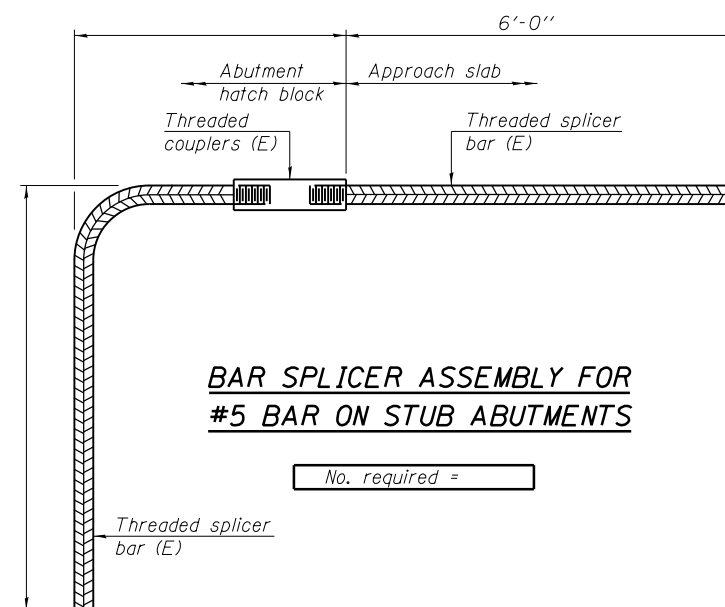

BAR SPLICER ASSEMBLY FOR #5 BAR ON STUB ABUTMENTS

No. required =

NOTES

- Splicer bars shall be deformed with threaded ends and have a minimum 60 ksi yield strength.
- All reinforcement shall be lapped and tied to the splicer bars.
- Bar splicer assemblies shall be epoxy coated according to the requirements for reinforcement bars. See Section 508 of the Standard Specifications.
- See special provision for Mechanical Splicers.
- See approved list of bar splicer assemblies and mechanical splicers for alternatives.

BSD-1 7-1-10
 BENTON & ASSOCIATES, INC.

FILE NAME = P:\10e2166-2\Design\Plans\082-0160 & 082-0161\0820160-76022-009-Splicer.dgn	USER NAME =	DESIGNED - MBH	REVISED - 10/3/13
	PLOT SCALE =	CHECKED - SJH	REVISED -
	PLOT DATE =	DRAWN - MBH	REVISED -
		CHECKED - SJH	REVISED -

STATE OF ILLINOIS
 DEPARTMENT OF TRANSPORTATION

BAR SPLICER ASSEMBLY AND MECHANICAL SPLICER DETAILS
 STRUCTURE NO. 082-0160 & 082-0161

SHEET NO. 10 OF 10 SHEETS

F.A.I. RTE.	SECTION	COUNTY	TOTAL SHEETS	SHEET NO.
64	82-2HBI	ST. CLAIR	208	176
CONTRACT NO. 76022				
FED. ROAD DIST. NO. 8 ILLINOIS FED. AID PROJECT				

INDEX OF SHEETS

General Plan & Elevation	1
Staging	2-4
Temporary Concrete Barrier For Stage Construction	5
Deck Repairs	6
Substructure Repairs	7
Bridge Approach Slab Details	8-9
Bar Splicer Assembly Details	10

GENERAL NOTES

- Fasteners shall be AASHTO M164 Type 1, mechanically galvanized bolts (in painted areas and M164 Type 3 in unpainted areas). Bolts $\frac{3}{8}$ " ϕ , holes $\frac{13}{16}$ " ϕ , unless otherwise noted.
- No field welding is permitted except as specified in the contract documents.
- Reinforcement bars designated (E) shall be epoxy coated.
- Prior to pouring the new concrete deck, all heavy or loose rust, loose mill scale, and other loose or potentially detrimental foreign material shall be removed from the surfaces in contact with concrete. Tightly adhered paint may remain unless otherwise noted. Removal shall be accomplished by methods that will not damage the steel and the cost will be included in the pay item covering removal of the existing concrete.
- As directed by the Engineer, existing construction accessories welded to the top flange of beams and girders shall be removed. The weld areas shall be ground flush and inspected for cracks using magnetic particle testing (MT) or dye penetrant testing (PT) by qualified personnel approved by the Engineer. Any cracks that can not be removed by grinding $\frac{1}{4}$ in. deep shall be identified and reported to the Bureau of Bridges and Structures for further disposition. The cost of removing welded accessories, grinding and inspecting weld areas and grinding cracks will be paid for according to Article 109.04 of the Standard Specifications.
- Plan dimensions and details relative to existing plans are subject to nominal construction variations. The Contractor shall field verify existing dimensions and details affecting new construction and make necessary approved adjustments prior to construction or ordering of materials. Such variations shall not be cause for additional compensation for a change in scope of the work, however, the Contractor will be paid for the quantity actually furnished at the unit price bid for the work.
- Existing reinforcement bars extending into the removal area shall be cleaned, straightened and incorporated into the new construction. Any reinforcement bars that are damaged during concrete removal shall be replaced with an approved bar splicer or anchorage system. Cost included with Concrete Removal.
- Areas of deck repairs shown are estimated. The Engineer shall show actual locations of deck repairs on As-built Plans.
- All structural steel shall be shop painted with the inorganic zinc rich primer per AASHTO M300, Type 1. Color to match existing. Cost included with Furnishing and Erecting Structural Steel.
- Existing reinforcement shall be cleaned and incorporated into the new construction. Cost included with Concrete Removal.
- Concrete anchors shall be epoxy adhesive anchors with sufficient embedment to match the bars yield strength.

TOTAL BILL OF MATERIAL

ITEM	UNIT	QUANTITY
Bridge Deck Concrete Sealer	Sq. Ft.	13240
Structural Repair of Concrete (Depth <= 5")	Sq. Ft.	116
Deck Slab Repair (Partial)	Sq. Yd.	1.6
Deck Slab Repair (Full)	Sq. Yd.	3.0
Protective Shield	Sq. Yd.	88
Concrete Removal	Cu. Yd.	306
Concrete Structure	Cu. Yd.	68
Concrete Superstructure	Cu. Yd.	320
Reinforcement Bars, Epoxy Coated	Pound	90190
Bar Splicers	Each	888
Concrete Anchors	Each	448

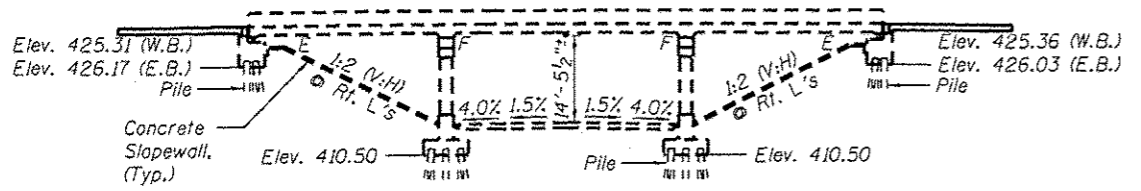

ELEVATION

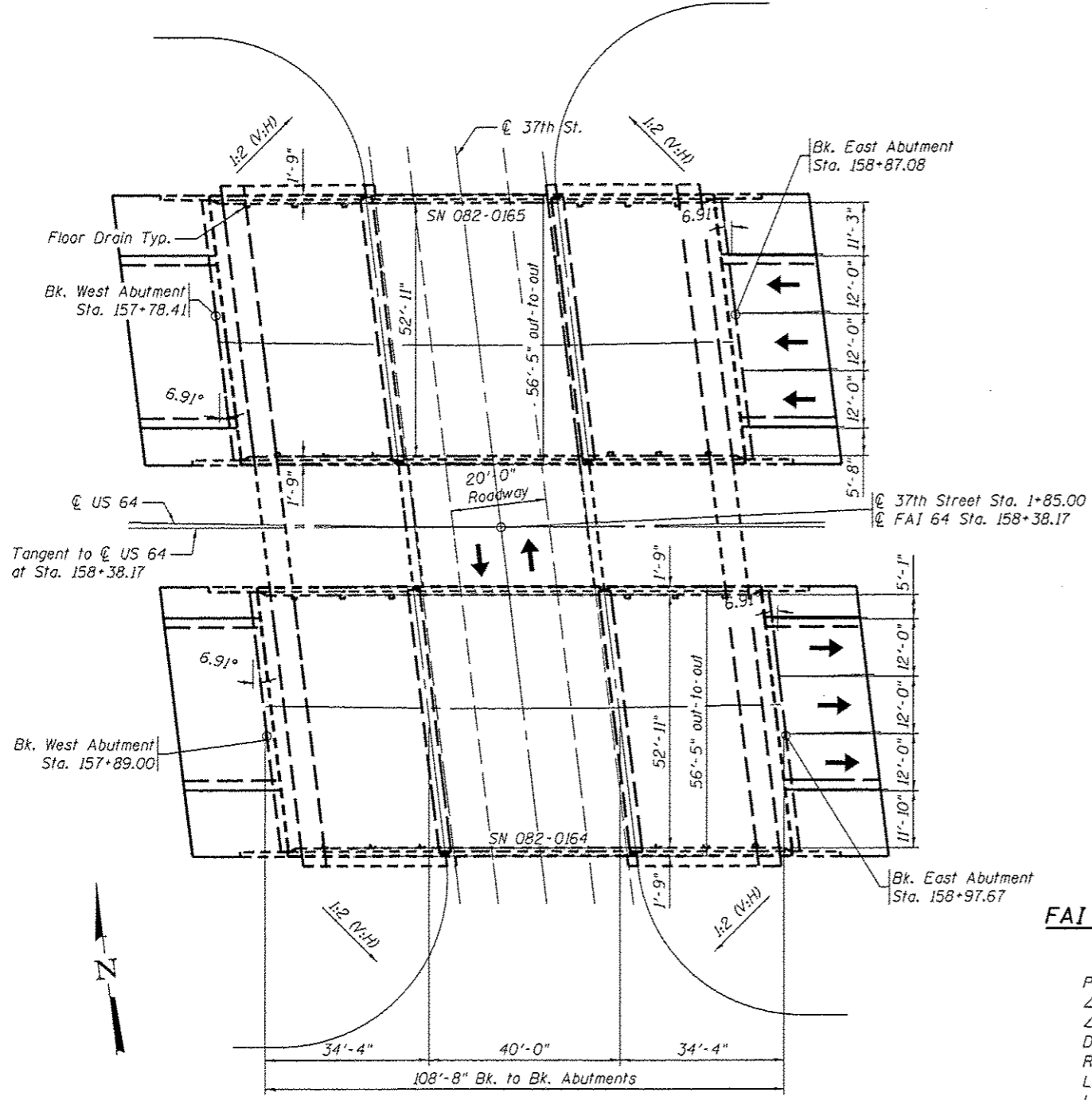

PLAN

FAI 64 CURVE DATA

(Spiral Curve)
 PI STA. = 157+18.07
 $\Delta = 16^\circ 51' 34''$
 $\Delta_c = 10^\circ 51' 34''$
 $D_c = 3^\circ 0' 0''$
 $R_c = 1,909.86'$
 $L_c = 361.98'$
 $L_s = 200.00'$
 $\theta_s = 3^\circ 0' 0''$
 $T_s = 383.16'$
 $E_s = 81.76'$
 $S.E. = 0.025'/FT.$

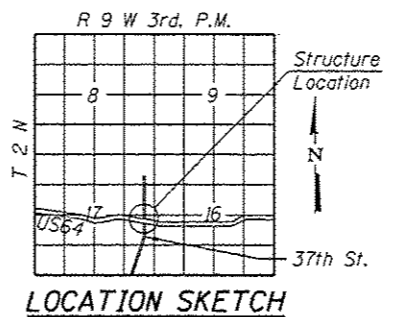

LOCATION SKETCH



ORIGINAL DESIGN STRESSES

FIELD UNITS
 $f'_c = 1,400$ psi (Piers and Superstructure)
 $f'_c = 1,000$ psi (Substructure w/ Earth Pressure)
 $f_y = 20,000$ psi (Reinforcement)
 $f_y = 20,000$ psi (Structural Steel A36)
 $n = 10$
 $N = 75$ psi

GENERAL PLAN & ELEVATION
INTERSTATE 64 OVER 37TH ST.
F.A.I. RTE. 64 - SEC. 82-3HB
ST. CLAIR COUNTY
US 64 STA. 158+38.17
37TH ST. STA. 1+85.00

BENTON & ASSOCIATES, INC.

STATE OF ILLINOIS
DEPARTMENT OF TRANSPORTATION

GENERAL PLAN & ELEVATION
STRUCTURE NO. 082-0164 & 082-0165

SHEET NO. 1 OF 10 SHEETS

F.A.I. RTE.	SECTION	COUNTY	TOTAL SHEETS	SHEET NO.
64	82-3HB	ST. CLAIR	208	177
CONTRACT NO. 76022			FED. ROAD DIST. NO. 8 (ILLINOIS) FED. AID PROJECT	

FILE NAME	USER NAME	DESIGNED	REVISION
P:\182166-2\Design\Plans\082-0164 & 082-0165		MBH	10/3/13
0820164-76022-081-GPE.dgn		S.JH	
		MBH	
		S.JH	

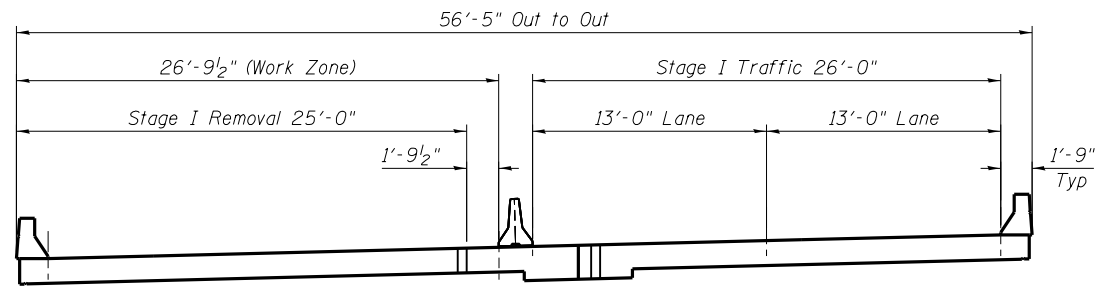

SN 082-0164 EASTBOUND CROSS SECTION
(Looking East)
STAGE I REMOVAL

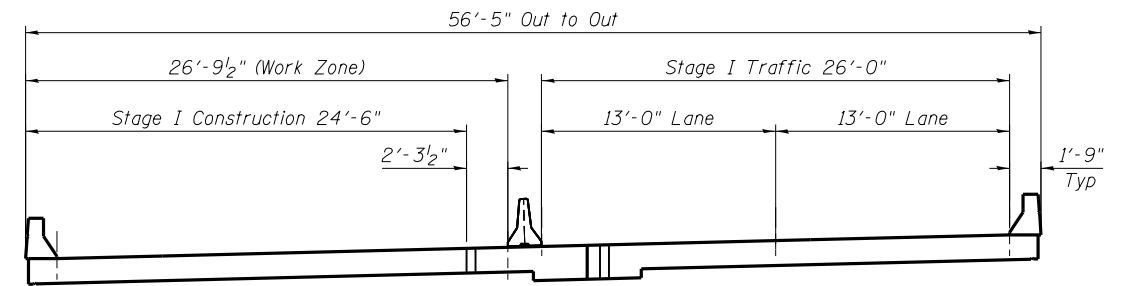

SN 082-0164 EASTBOUND CROSS SECTION
(Looking East)
STAGE I CONSTRUCTION

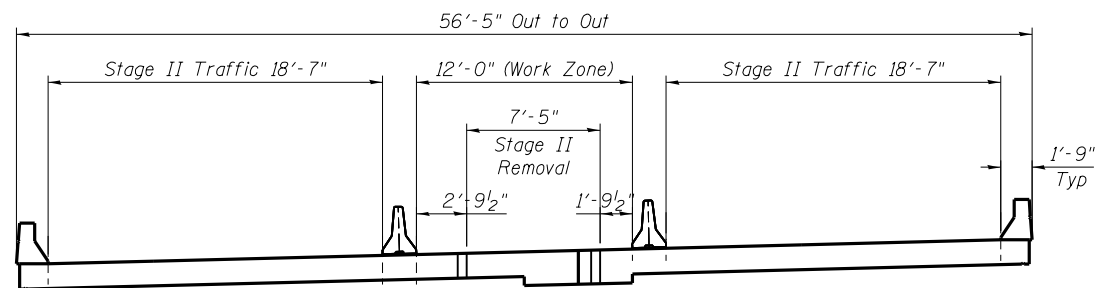

SN 082-0164 EASTBOUND CROSS SECTION
(Looking East)
STAGE II REMOVAL

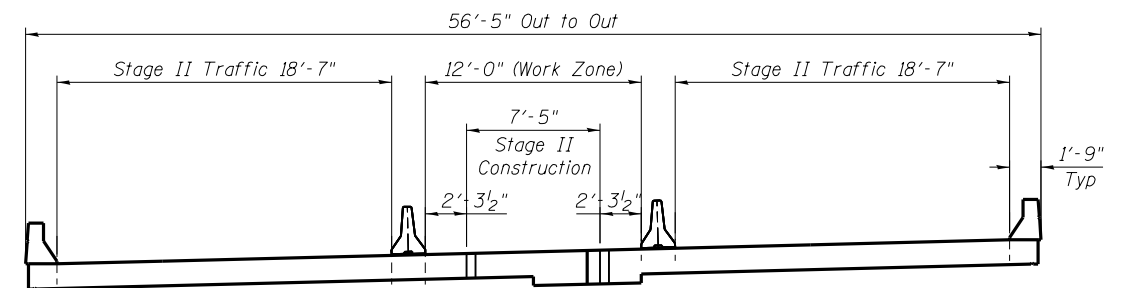

SN 082-0164 EASTBOUND CROSS SECTION
(Looking East)
STAGE II CONSTRUCTION

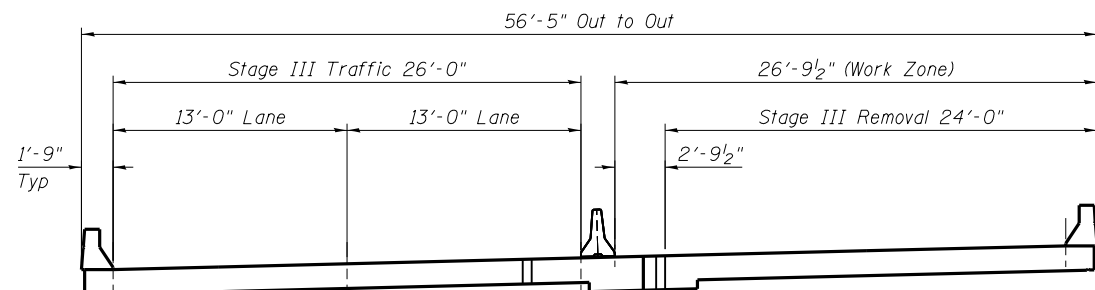

SN 082-0164 EASTBOUND CROSS SECTION
(Looking East)
STAGE III REMOVAL

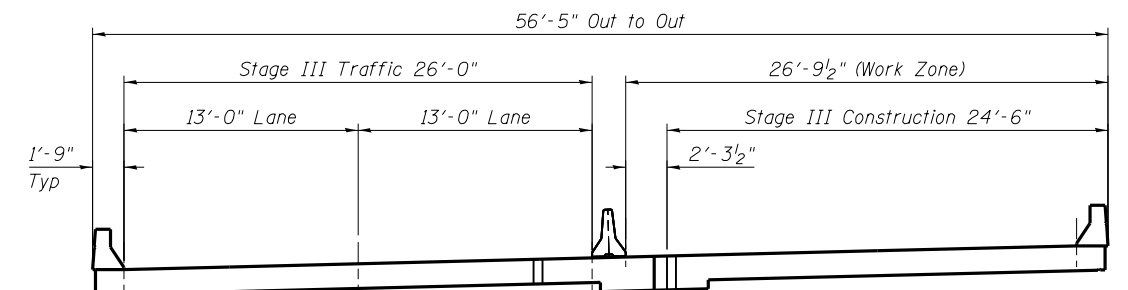

SN 082-0164 EASTBOUND CROSS SECTION
(Looking East)
STAGE III CONSTRUCTION

BENTON & ASSOCIATES, INC.

FILE NAME = P:\10e2166-2\Design\	USER NAME =	DESIGNED - MBH	REVISED -
Plans\082-0164 & 082-0165		CHECKED - SJH	REVISED -
0820164-76022-002-Staging.dgn	PLOT SCALE =	DRAWN - MBH	REVISED -
	PLOT DATE =	CHECKED - SJH	REVISED -

STATE OF ILLINOIS
DEPARTMENT OF TRANSPORTATION

STAGING SECTIONS
STRUCTURE NO. 082-0164

SHEET NO. 2 OF 10 SHEETS

F.A.I. RTE.	SECTION	COUNTY	TOTAL SHEETS	SHEET NO.
64	82-3HB	ST. CLAIR	208	178
CONTRACT NO. 76022				
FED. ROAD DIST. NO. 8 ILLINOIS FED. AID PROJECT				

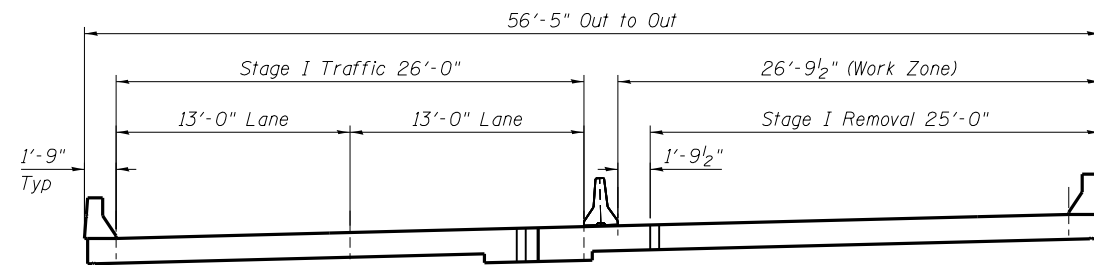

SN 082-0165 WESTBOUND CROSS SECTION
(Looking East)

STAGE I REMOVAL

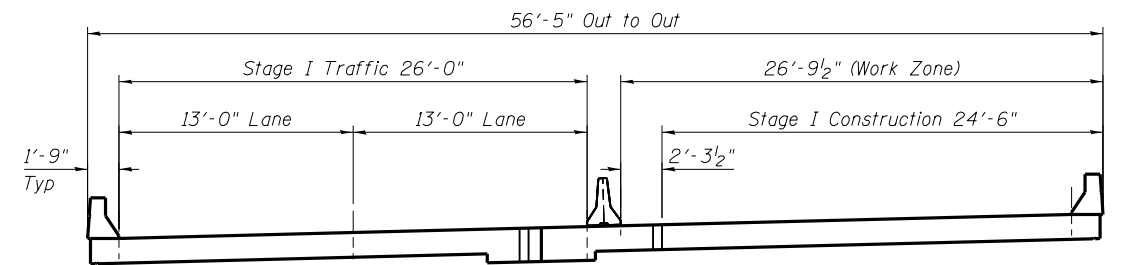

SN 082-0165 WESTBOUND CROSS SECTION
(Looking East)

STAGE I CONSTRUCTION

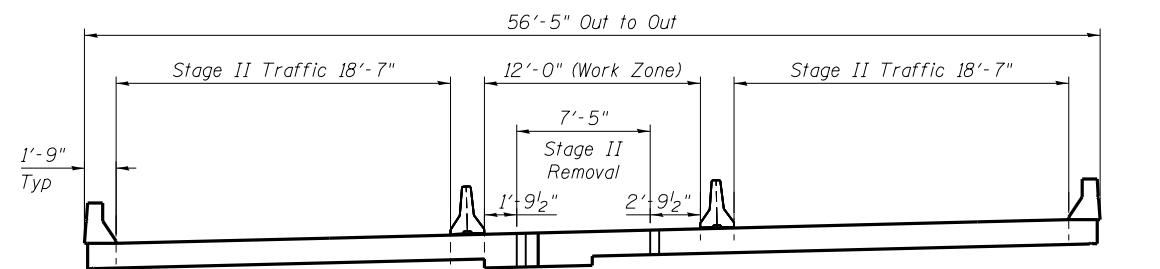

SN 082-0165 WESTBOUND CROSS SECTION
(Looking East)

STAGE II REMOVAL

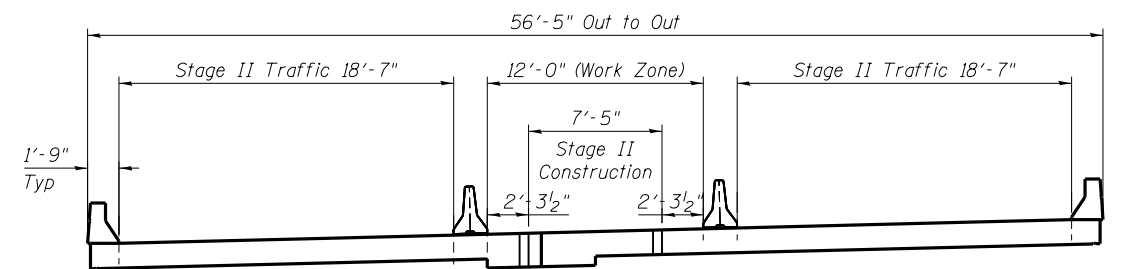

SN 082-0165 WESTBOUND CROSS SECTION
(Looking East)

STAGE II CONSTRUCTION

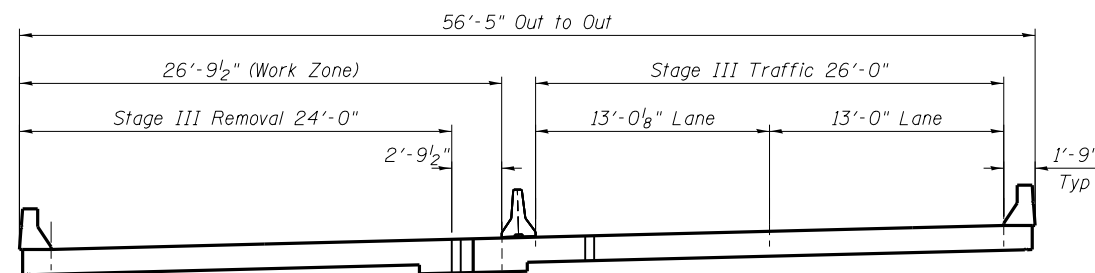

SN 082-0165 WESTBOUND CROSS SECTION
(Looking East)

STAGE III REMOVAL

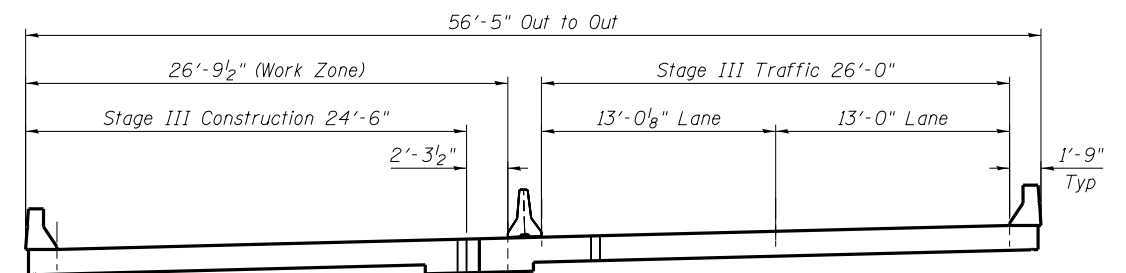

SN 082-0165 WESTBOUND CROSS SECTION
(Looking East)

STAGE III CONSTRUCTION

BENTON & ASSOCIATES, INC.

FILE NAME = P:\10e2166-2\Design\	USER NAME =	DESIGNED - MBH	REVISED -
Plans\082-0164 & 082-0165		CHECKED - SJH	REVISED -
0820164-76022-002-Staging.dgn	PLOT SCALE =	DRAWN - MBH	REVISED -
	PLOT DATE =	CHECKED - SJH	REVISED -

**STATE OF ILLINOIS
DEPARTMENT OF TRANSPORTATION**

**STAGING SECTIONS
STRUCTURE NO. 082-0165**

SHEET NO. 3 OF 10 SHEETS

F.A.I. RTE.	SECTION	COUNTY	TOTAL SHEETS	SHEET NO.
64	82-3HB	ST. CLAIR	208	179
CONTRACT NO. 76022				
FED. ROAD DIST. NO. 8 ILLINOIS FED. AID PROJECT				

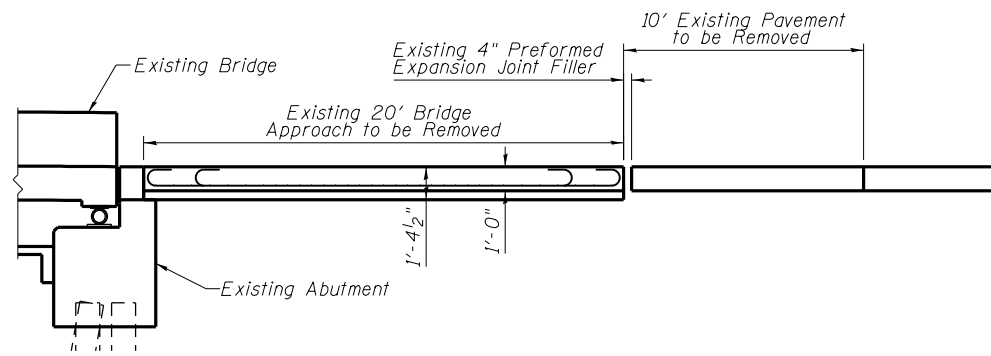

Section

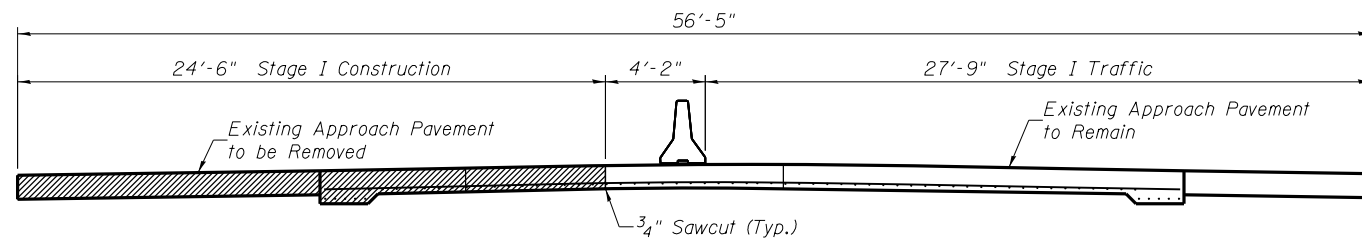

STAGE I CROSS SECTION

SN 082-0164 (Looking East)
SN 082-0165 (Similar Looking West)

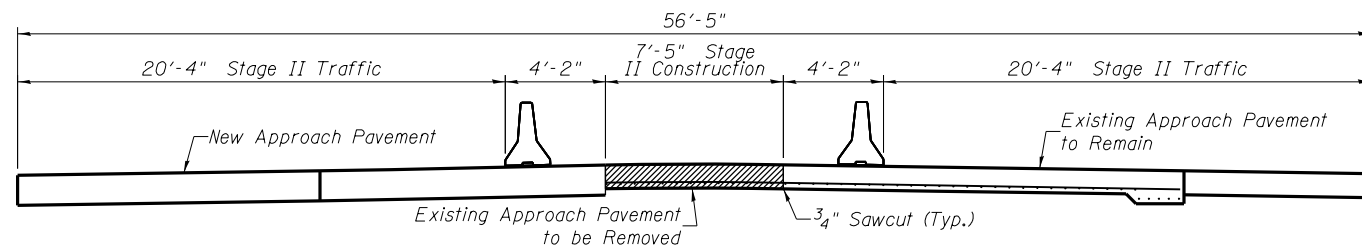

STAGE II CROSS SECTION

SN 082-0164 (Looking East)
SN 082-0165 (Similar Looking West)

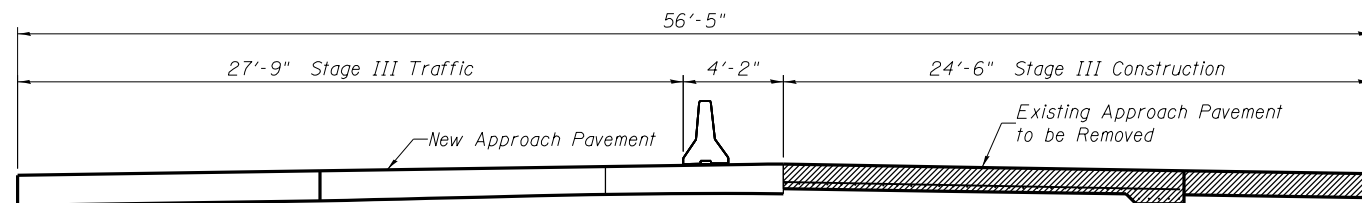

STAGE III CROSS SECTION

SN 082-0164 (Looking East)
SN 082-0165 (Similar Looking West)

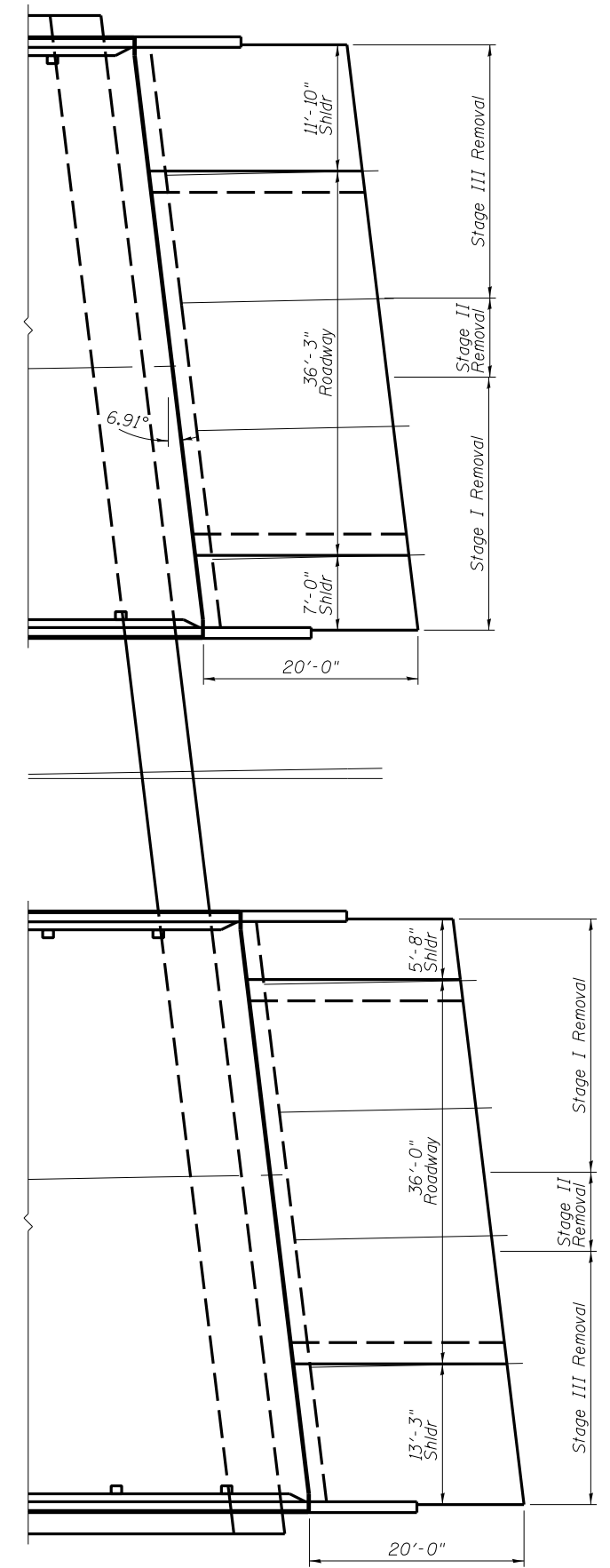

Existing Plan

(East Abutments, West Abutments similar)

FILE NAME = P:\10e2166-2\ Design\
Plans\ 0820164-76022-002-
Staging.dgn

USER NAME =
PLOT SCALE =
PLOT DATE =

DESIGNED - MBH
CHECKED - RHB
DRAWN - MBH
CHECKED - RHB

REVISED - 10/3/13
REVISED -
REVISED -
REVISED -

**STATE OF ILLINOIS
DEPARTMENT OF TRANSPORTATION**

**STAGING SECTIONS
STRUCTURE NO. 082-0164 & 082-0165**

SHEET NO. 4 OF 10 SHEETS

F.A.I. RTE.	SECTION	COUNTY	TOTAL SHEETS	SHEET NO.
64	82-3HB	ST. CLAIR	208	180
CONTRACT NO. 76022				
FED. ROAD DIST. NO. 8 ILLINOIS FED. AID PROJECT				

When "A" is 3'-6" or less, the temporary concrete barrier shall be anchored to the new slab according to Detail I or Detail II. No anchorage is required when "A" is greater than 3'-6".

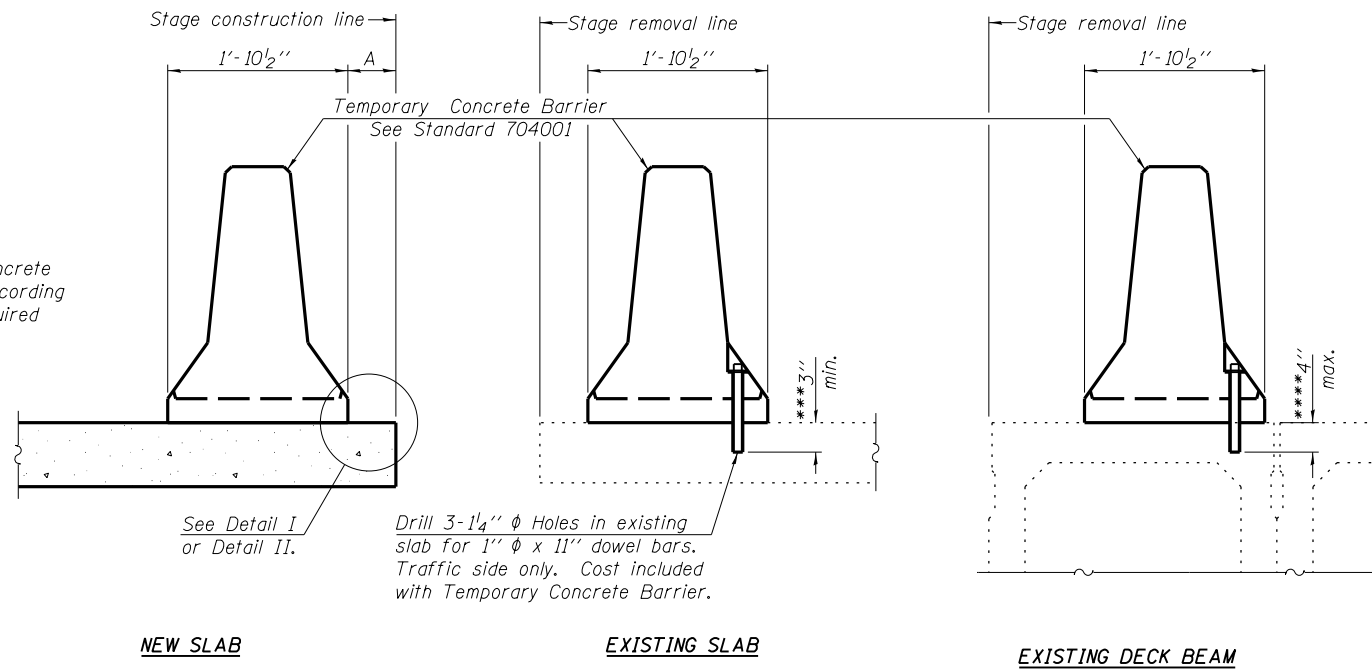

SECTIONS THRU SLAB OR DECK BEAM

NOTES

Detail I - With Bar Splicer or Couplers:
Connect one (1) 1" x 7" x "W" steel PL to the top layer of couplers with 2-5/8" φ bolts screwed to coupler at approximate C of each barrier panel.

Detail II - With Extended Reinforcement Bars:
Connect one (1) 1" x 7" x "W" steel PL to the concrete slab or concrete wearing surface with 2-5/8" φ Expansion Anchors or cast in place inserts spaced between the top layer of reinforcement at approximate C of each barrier panel.

Cost of anchorage is included with Temporary Concrete Barrier. The 1" x 7" x "W" plate shall not be removed until stage II construction forms and all reinforcement bars are in place and the concrete is ready to be placed.

*** Dimension shown is minimum required embedment into concrete. If hot-mix asphalt wearing surface is present, minimum embedment shall be in addition to wearing surface depth.

**** If existing deck beam is to remain in place after stage construction, embedment shall only be into wearing surface and not into existing deck beam concrete.

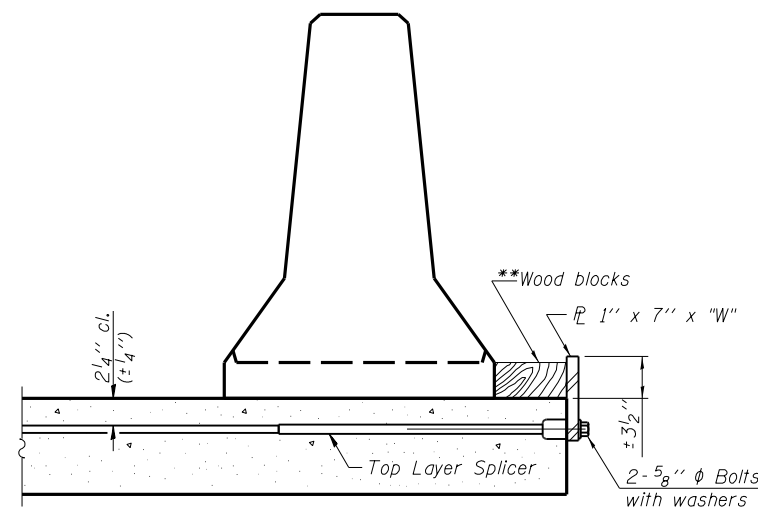

DETAIL I

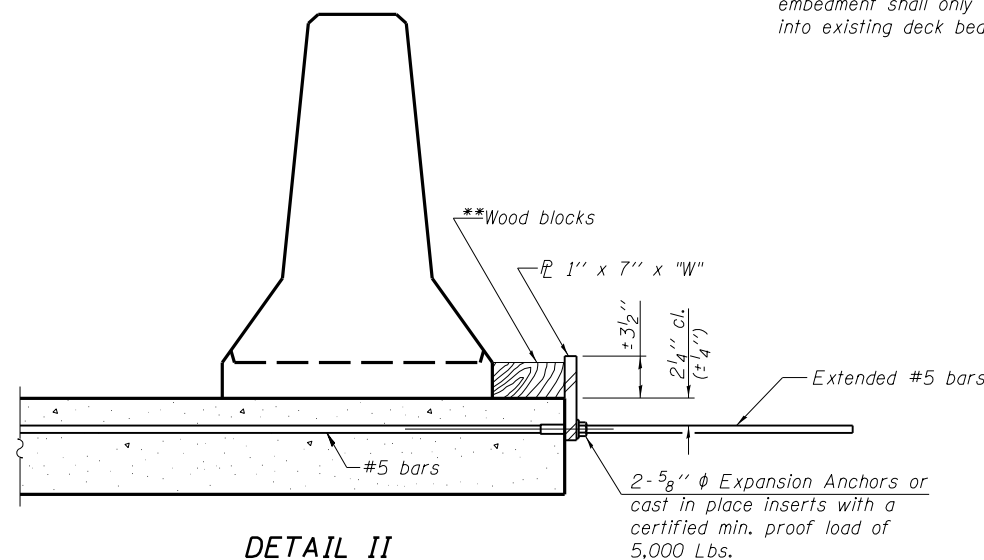

DETAIL II

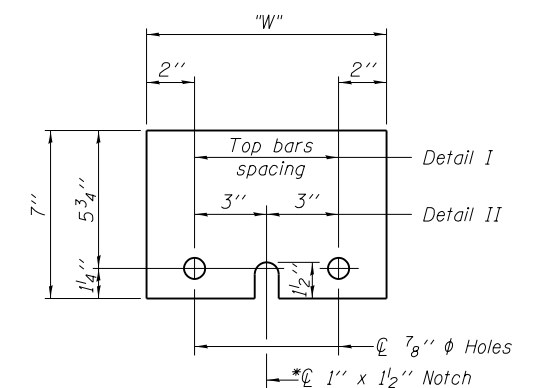

STEEL RETAINER PL 1" x 7" x "W"

* Required only with Detail II

** Wood blocks may be omitted when required to provide minimum stage traffic lane width. When the wood blocks are omitted, the concrete barrier shall be in direct contact with the steel retainer plate.

"W" = Top bars spacing + 4"

R-27 7-1-10
BENTON & ASSOCIATES, INC.

FILE NAME = P:\10e2166-2\Design\	USER NAME =	DESIGNED - MBH	REVISED -
Plans\082-0164 & 082-0165		CHECKED - SJH	REVISED -
0820164-76022-003-Barrier.dgn	PLOT SCALE =	DRAWN - MBH	REVISED -
	PLOT DATE =	CHECKED - SJH	REVISED -

STATE OF ILLINOIS
DEPARTMENT OF TRANSPORTATION

TEMPORARY CONCRETE BARRIER FOR STAGE CONSTRUCTION
STRUCTURE NO. 082-0164 & 082-0165

SHEET NO. 5 OF 10 SHEETS

F.A.I. RTE.	SECTION	COUNTY	TOTAL SHEETS	SHEET NO.
64	82-1HB1-2	ST. CLAIR	208	181
CONTRACT NO. 76022				
FED. ROAD DIST. NO. 8 ILLINOIS FED. AID PROJECT				

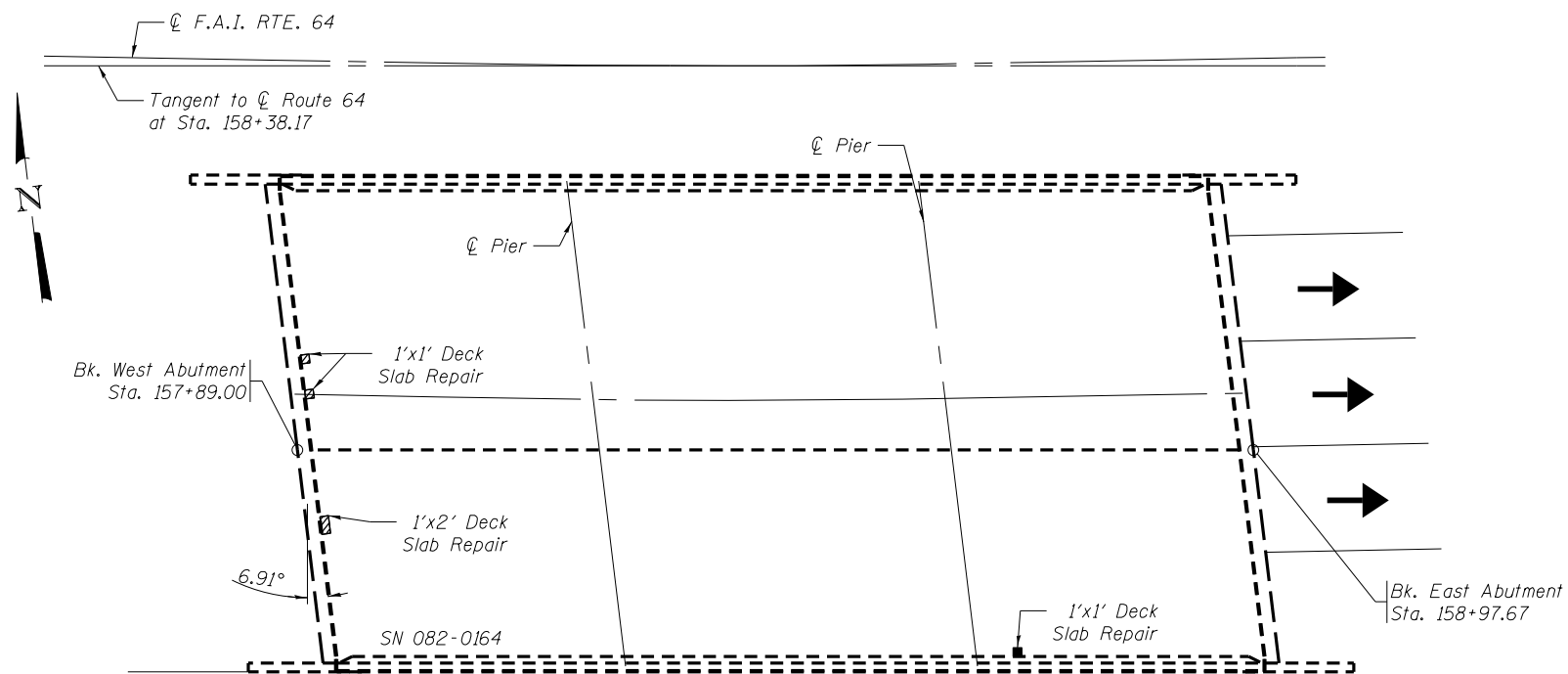
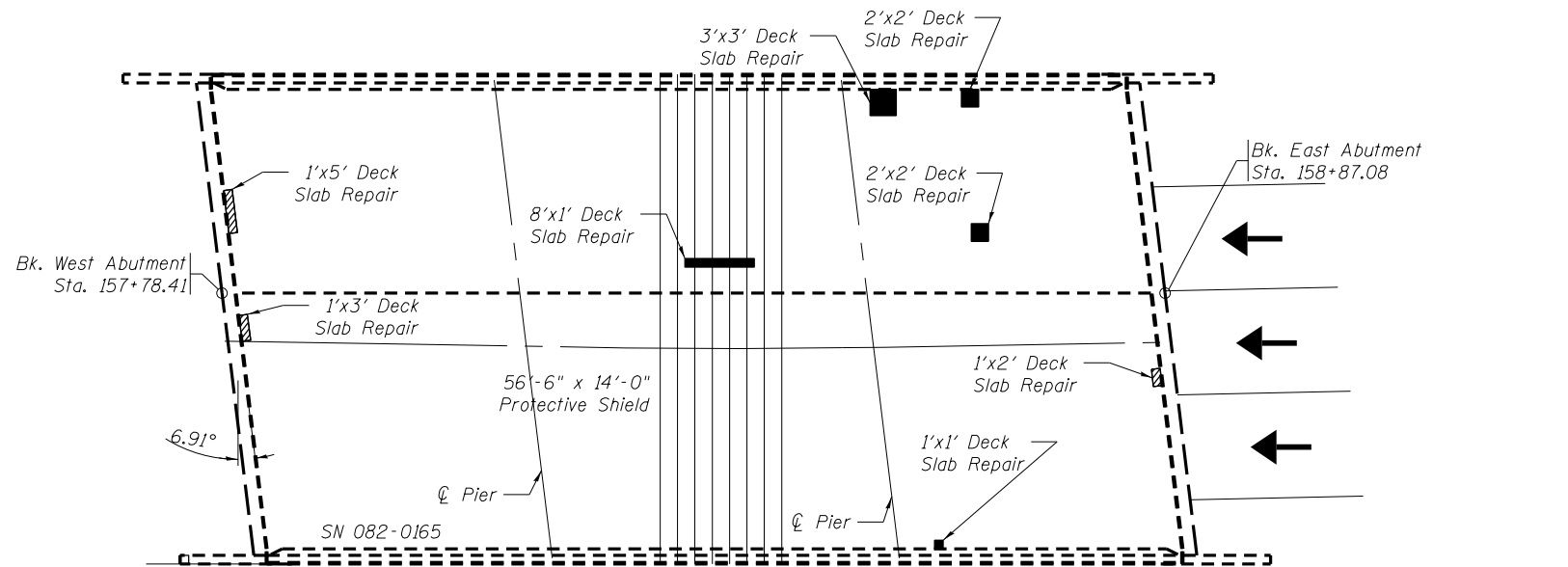

DECK REPAIR PLAN

LEGEND

- ▨ Area of Partial Depth Deck Repair
- Area of Full Depth Deck Repair

BILL OF MATERIAL

ITEM	UNIT	QUANTITY
Deck Slab Repair (Full)	Sq. Yd.	3.0
Deck Slab Repair (Partial)	Sq. Yd.	1.6
Protective Shield	Sq. Yd.	88

BENTON & ASSOCIATES, INC.

FILE NAME = P:\10e2166-2\Design\	USER NAME =	DESIGNED - MBH	REVISED - 10/3/13
Plans\ 082-0164 & 082-0165		CHECKED - SJH	REVISED -
0820164-76022-004-Deck.dgn	PLOT SCALE =	DRAWN - MBH	REVISED -
	PLOT DATE =	CHECKED - SJH	REVISED -

**STATE OF ILLINOIS
DEPARTMENT OF TRANSPORTATION**

**DECK REPAIRS
STRUCTURE NO. 082-0164 & 082-0165**

SHEET NO. 6 OF 10 SHEETS

F.A.I. RTE.	SECTION	COUNTY	TOTAL SHEETS	SHEET NO.
64	82-3HB	ST. CLAIR	208	182
CONTRACT NO. 76022				
FED. ROAD DIST. NO. 8 ILLINOIS FED. AID PROJECT				

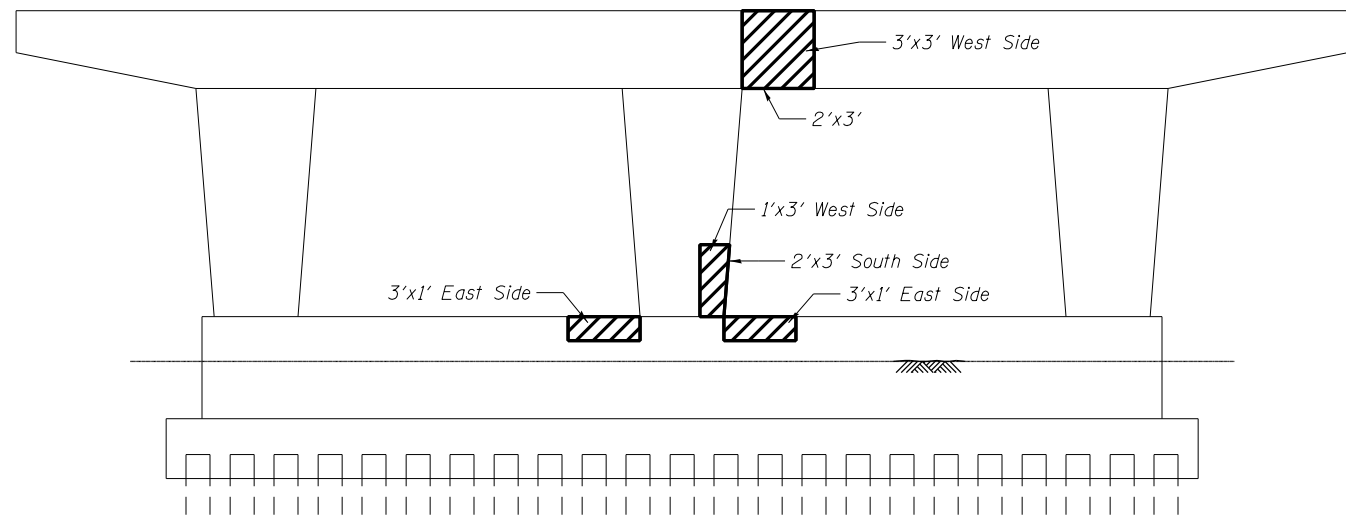

STRUCTURE 082-0164 WEST PIER

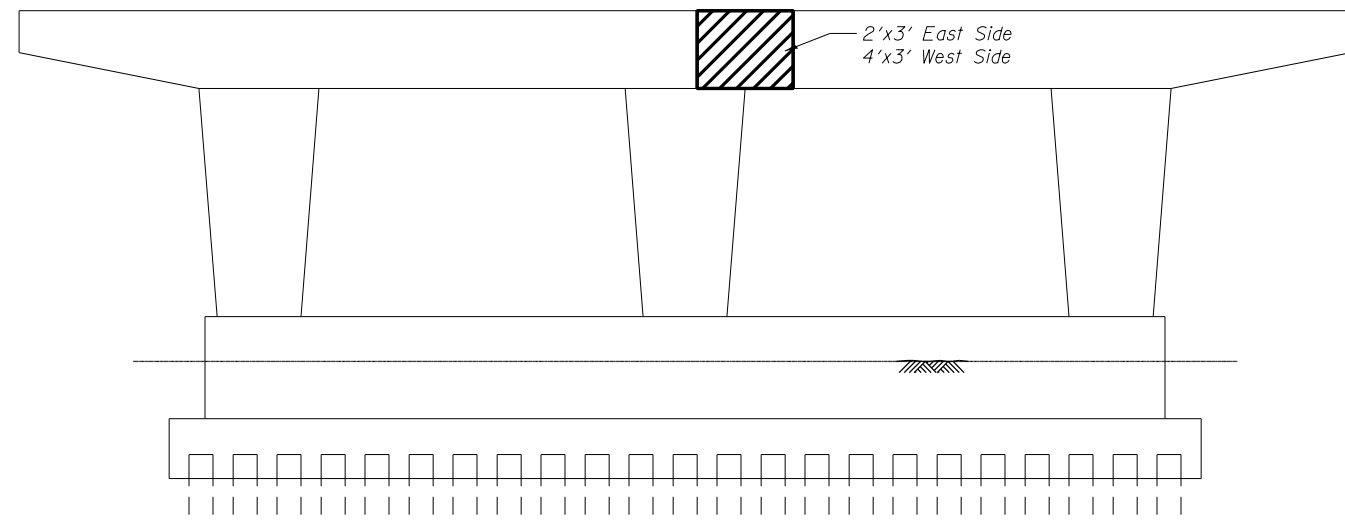

STRUCTURE 082-0165 WEST PIER

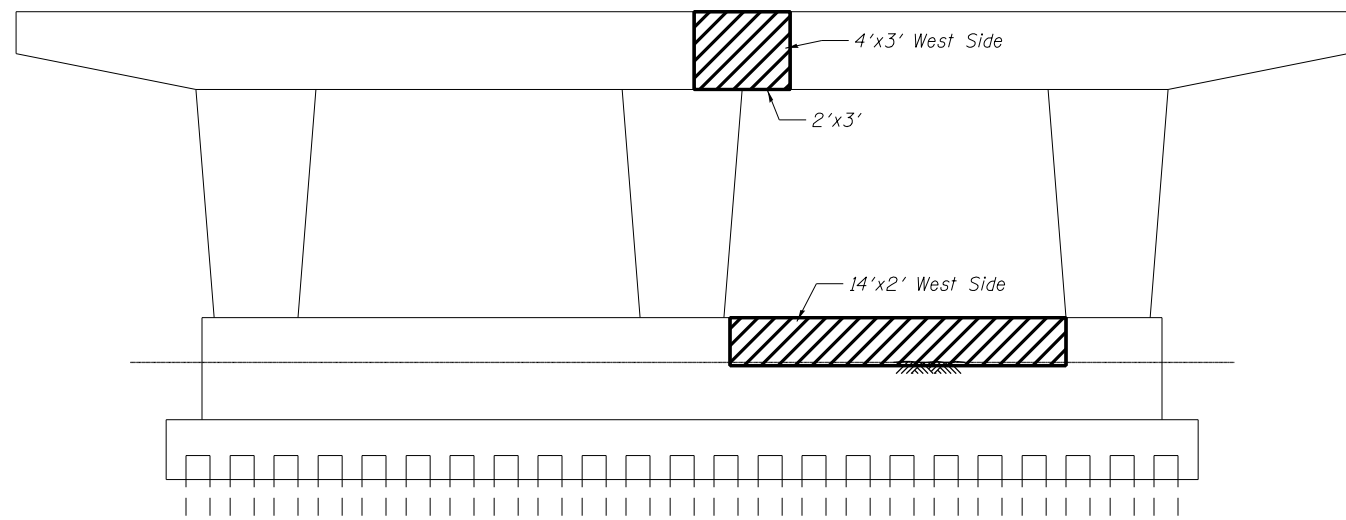

STRUCTURE 082-0164 EAST PIER

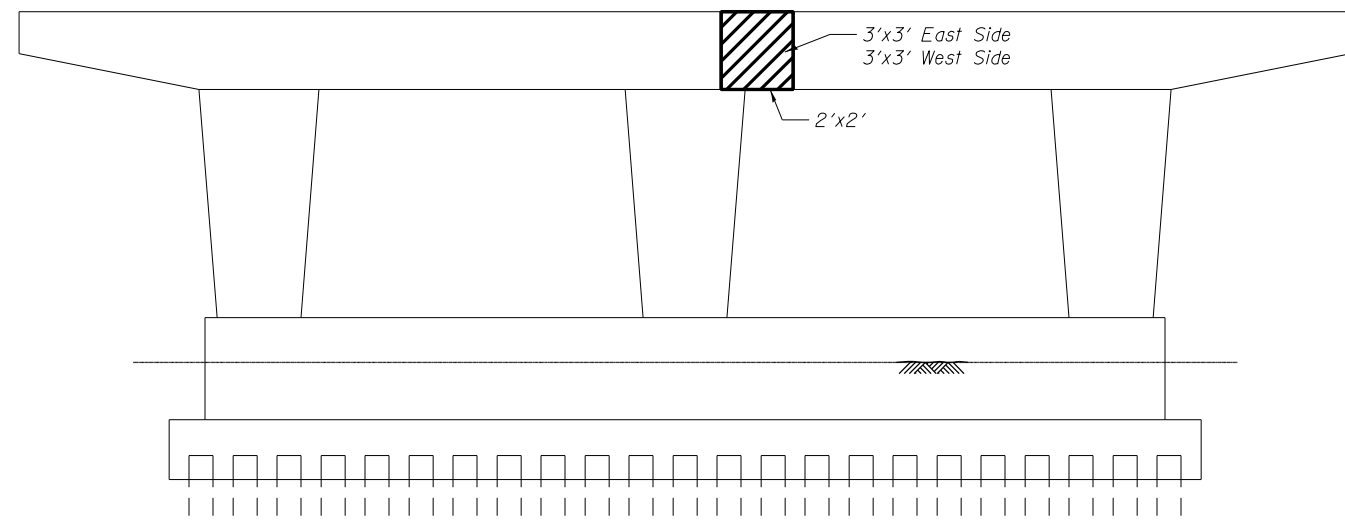

STRUCTURE 082-0165 EAST PIER

LEGEND

Area of Structural Concrete Repair

BILL OF MATERIAL

Item	Unit	Total
Structural Repair of Concrete (Depth <= 5")	Sq. Ft.	116

BENTON & ASSOCIATES, INC.

FILE NAME = P:\10e2166-2\Design\	USER NAME =	DESIGNED - MBH	REVISED -
Plans\ 082-0164 & 082-0165		CHECKED - SJH	REVISED -
0820164-76022-005-Piers.dgn	PLOT SCALE =	DRAWN - MBH	REVISED -
	PLOT DATE =	CHECKED - SJH	REVISED -

**STATE OF ILLINOIS
DEPARTMENT OF TRANSPORTATION**

**SUBSTRUCTURE REPAIRS
STRUCTURE NO. 082-0164 & 082-0165**

SHEET NO. 7 OF 10 SHEETS

F.A.I. RTE.	SECTION	COUNTY	TOTAL SHEETS	SHEET NO.
64	82-3HB	ST. CLAIR	208	183
CONTRACT NO. 76022				
FED. ROAD DIST. NO. 8 ILLINOIS FED. AID PROJECT				

Notes:
See sheet 9 of 9 for Sections C-C & D-D and View E-E.
a(E), a₁(E), a₂(E), and a₃(E) bar spacings measured along \hat{C} Rdwy.

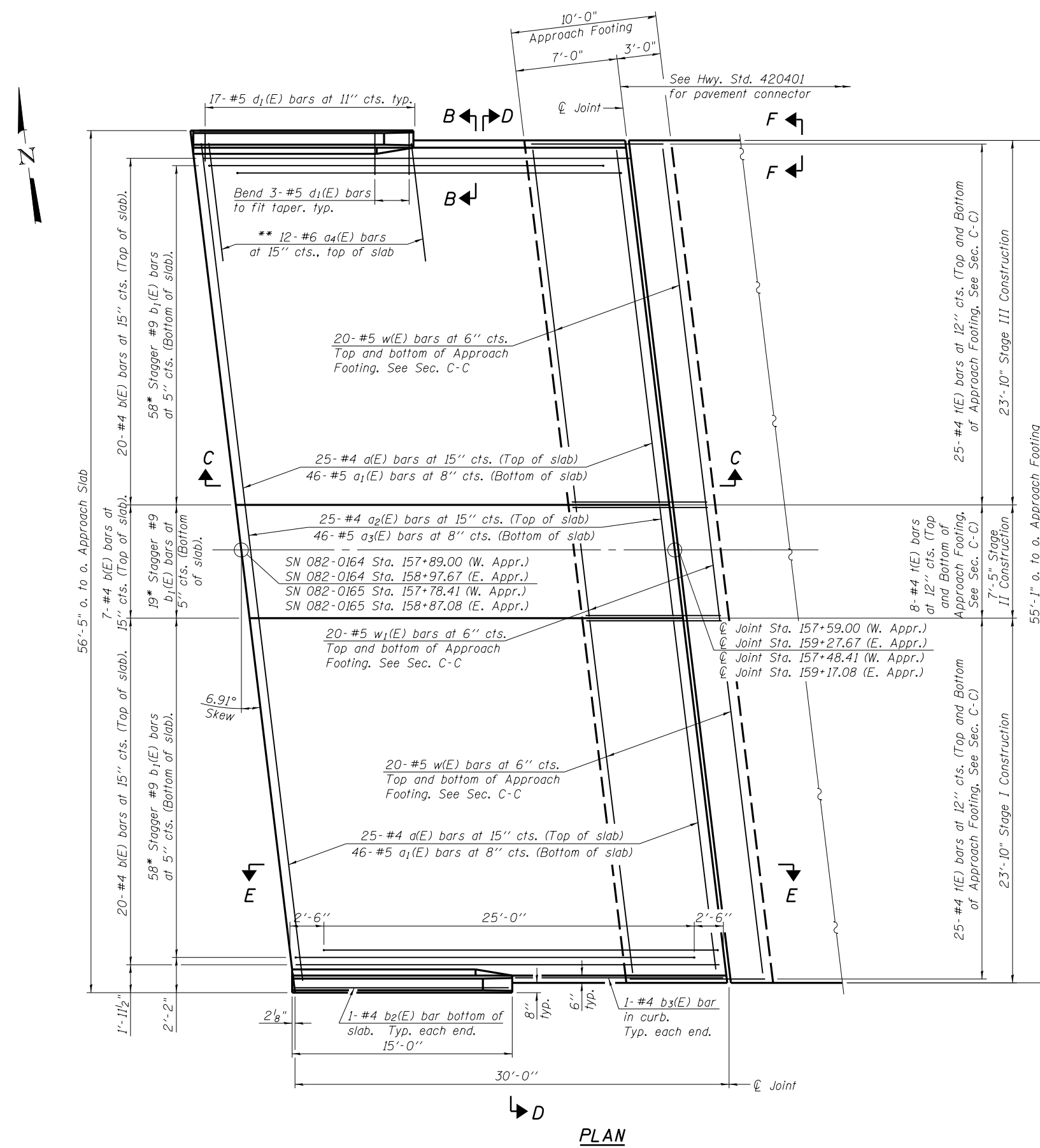

PLAN

* Tilt #9 b₁(E) bars as required to maintain clearance.
** Space between a(E) bars, typ. each parapet.

BA-R
BENTON & ASSOCIATES, INC.
7-1-10

FILE NAME = P:\10e2166-4\Design\Plans\0820164-76022-004-Appr1.dgn

USER NAME =	DESIGNED - MBH	REVISD -
PLOT SCALE =	CHECKED - RHB	REVISD -
PLOT DATE =	DRAWN - MBH	REVISD -
	CHECKED - RHB	REVISD -

STATE OF ILLINOIS
DEPARTMENT OF TRANSPORTATION

BRIDGE APPROACH SLAB DETAILS
STRUCTURE NO. 082-0164 & 082-0165

SHEET NO. 8 OF 10 SHEETS

F.A.P. RTE.	SECTION	COUNTY	TOTAL SHEETS	SHEET NO.
64	82-3HB	ST. CLAIR	208	184
CONTRACT NO. 76D22				
FED. ROAD DIST. NO. 8 ILLINOIS FED. AID PROJECT				

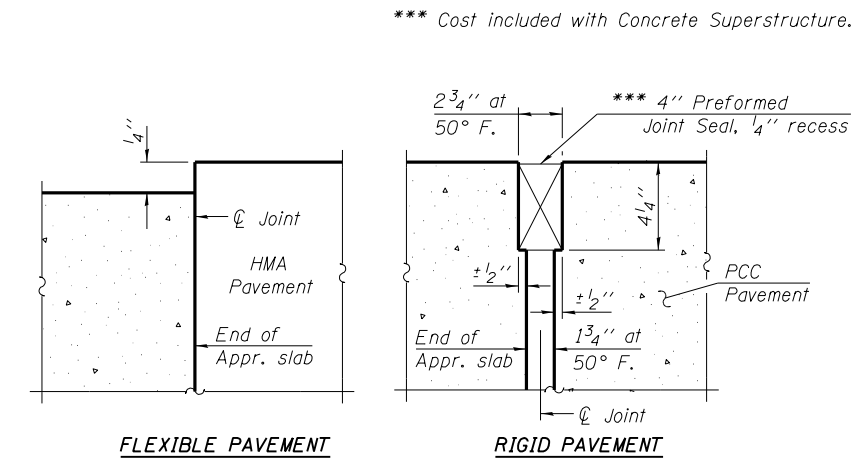

DETAIL A

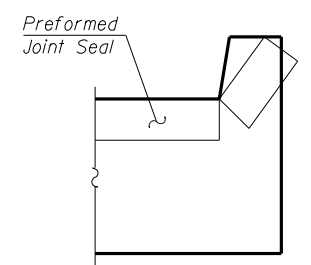

VIEW F-F

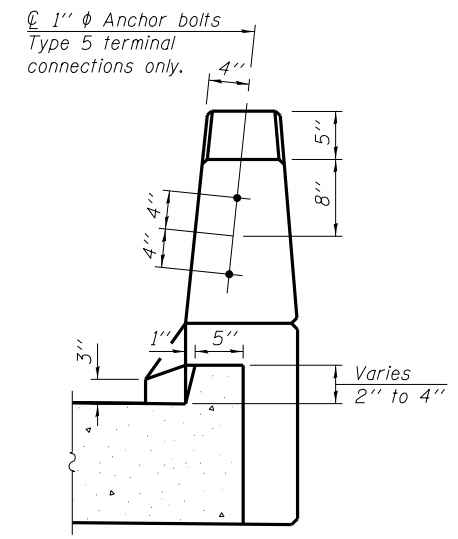

VIEW B-B

Notes:
 See sheet Z of 9 for Detail A and View B-B.
 Approach slab and parapet concrete shall be paid for as Concrete Superstructure.
 Approach footing concrete shall be paid for as Concrete Structures.
 Reinforcement shall be paid for as Reinforcement Bars, Epoxy Coated.
 For v(E) bar details, see sheet 8 of 9.
 The approach footing maximum applied service bearing pressure (Qmax) = 2.0 ksf.
 For bar splicer details, see sheet 9 of 9.
 Cost of excavation for approach footing included with Concrete Structures.

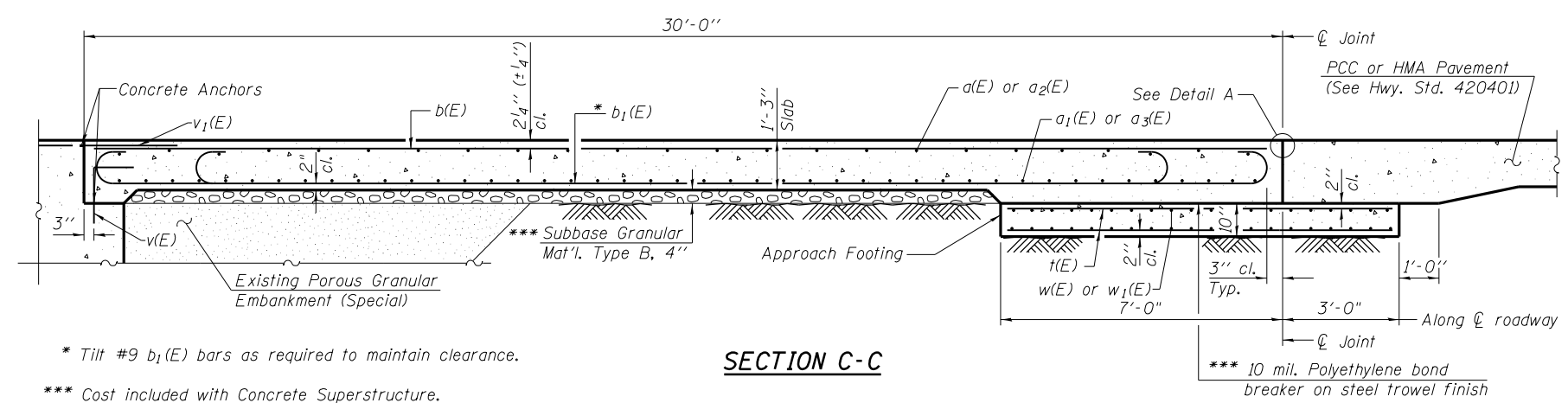

* Tilt #9 b1(E) bars as required to maintain clearance.
 *** Cost included with Concrete Superstructure.

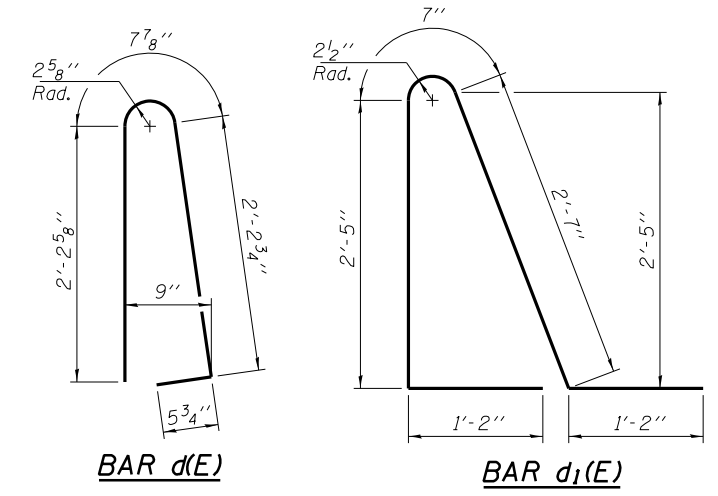

BOTTOM OF SPREAD FOOTING ELEVATIONS

Structure No.	Approach Pavement	Construction Stage	Bot. Slab Elev.
082-0164	West	North End	429.84
		South End	431.20
	East	North End	429.82
		South End	431.18
082-0165	West	North End	429.67
		South End	431.03
	East	North End	429.69
		South End	431.05

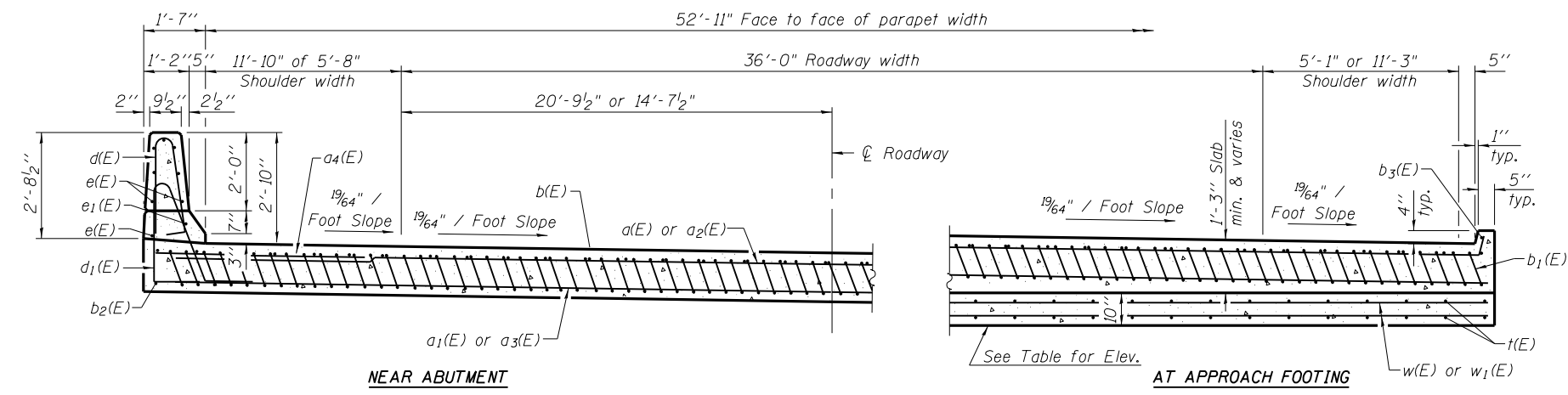

SECTION D-D
 (See Plan for dimensions not shown)

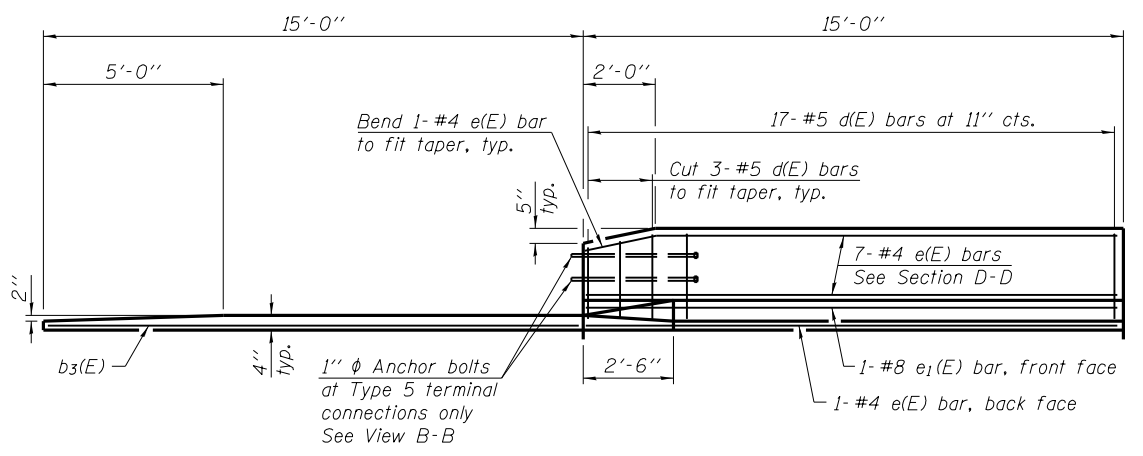
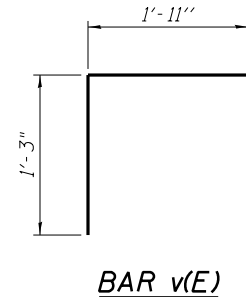

VIEW E-E

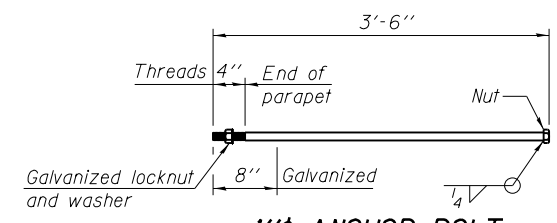

1" ANCHOR BOLT
 (Cost included with Concrete Superstructure)

Non-staining gray one component non-sag elastomeric gun grade polyurethane sealant meeting the requirements of ASTM C-920, Type S, Grade NS, Class 25. Use T with a 5/8" backer rod.

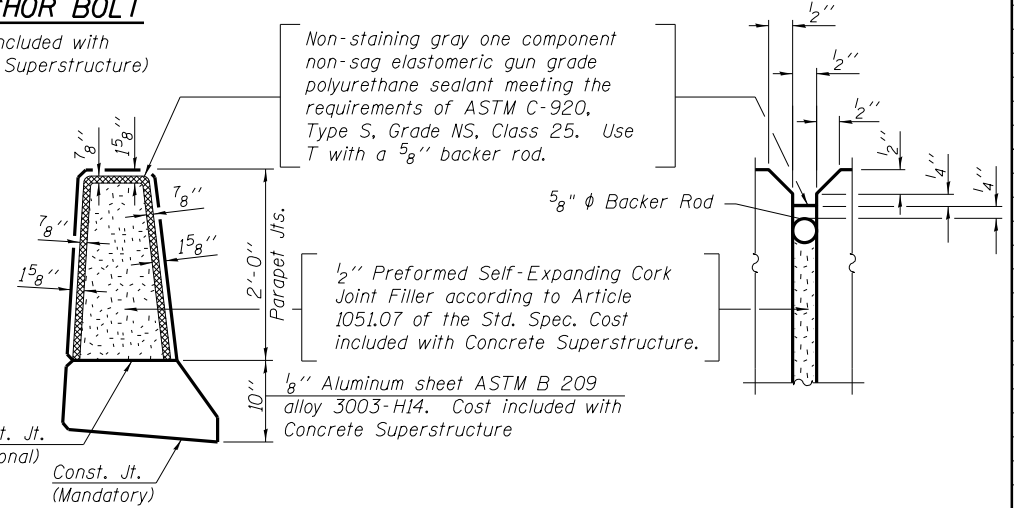

PARAPET JOINT DETAILS

FOUR APPROACHES BILL OF MATERIAL

Bar	No.	Size	Length	Shape
a(E)	200	#4	24'-3"	┌───┐
a1(E)	368	#5	23'-8"	┌───┐
a2(E)	100	#5	7'-2"	┌───┐
a3(E)	184	#5	7'-2"	┌───┐
a4(E)	96	#6	6'-6"	┌───┐
b(E)	188	#4	29'-8"	┌───┐
b1(E)	540	#9	29'-9"	┌───┐
b2(E)	8	#4	14'-8"	┌───┐
b3(E)	8	#4	14'-8"	┌───┐
d(E)	136	#5	5'-7"	┌───┐
d1(E)	136	#5	7'-11"	┌───┐
e(E)	64	#4	14'-8"	┌───┐
e1(E)	8	#8	14'-8"	┌───┐
t(E)	464	#4	9'-9"	┌───┐
w(E)	320	#5	23'-8"	┌───┐
w1(E)	160	#5	7'-2"	┌───┐
v(E)	224	#5	3'-2"	┌──┐
v1(E)	224	#5	2'-6"	┌──┐
Concrete Superstructure	Cu. Yd.		320	
Concrete Structures	Cu. Yd.		68	
Reinforcement Bars, Epoxy Coated	Pound		90190	
Concrete Anchors	Each		448	
Bar Splicers	Each		888	

BA-R 7-1-10
BENTON & ASSOCIATES, INC.

FILE NAME =	USER NAME =	DESIGNED -	REVISED -
P:\10e2166-4\ Design\ Plans\ 0820164-76022-005-Appr2.dgn		MBH	
		CHECKED - RHB	REVISED -
		DRAWN - MBH	REVISED -
		CHECKED - RHB	REVISED -

STATE OF ILLINOIS
DEPARTMENT OF TRANSPORTATION

BRIDGE APPROACH SLAB DETAILS
STRUCTURE NO. 082-0164 & 082-0165

SHEET NO. 9 OF 10 SHEETS

F.A.P. RTE.	SECTION	COUNTY	TOTAL SHEETS	SHEET NO.
64	82-3HB	ST. CLAIR	208	185

CONTRACT NO. 76022
 FED. ROAD DIST. NO. 8 ILLINOIS FED. AID PROJECT

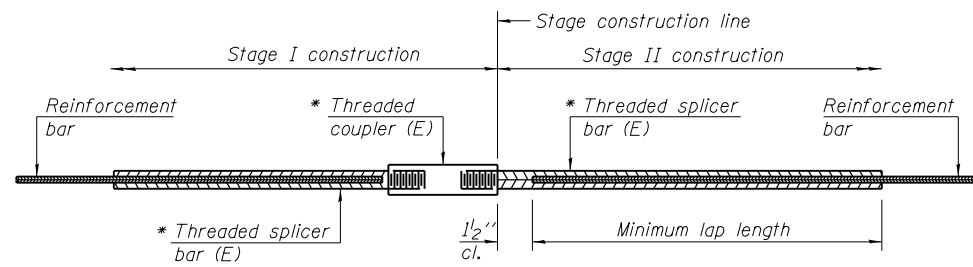

STANDARD BAR SPLICER ASSEMBLY

Minimum Lap Lengths					
Bar size to be spliced	Table 1	Table 2	Table 3	Table 4	Table 5
3, 4	1'-5"	1'-11"	2'-1"	2'-4"	2'-3"
5	1'-9"	2'-5"	2'-7"	2'-11"	2'-10"
6	2'-1"	2'-11"	3'-1"	3'-6"	3'-4"
7	2'-9"	3'-10"	4'-2"	4'-8"	4'-6"
8	3'-8"	5'-1"	5'-5"	6'-2"	5'-10"
9	4'-7"	6'-5"	6'-10"	7'-9"	7'-5"

- Table 1: Black bar, 0.8 Class C
- Table 2: Black bar, Top bar lap, 0.8 Class C
- Table 3: Epoxy bar, 0.8 Class C
- Table 4: Epoxy bar, Top bar lap, 0.8 Class C
- Table 5: Epoxy bar, Top bar lap, Class B

Threaded splicer bar length = min. lap length + 1/2" + thread length

* Epoxy not required on Bar Splicer Assembly components used in conjunction with black bars.

Location	Bar size	No. assemblies required	Table for minimum lap length
SN 082-0164 Deck	#4	100	Table 3
SN 082-0164 Deck	#5	184	Table 3
SN 082-0164 Base	#5	160	Table 3
SN 082-0165 Deck	#4	100	Table 3
SN 082-0165 Deck	#5	184	Table 3
SN 082-0165 Base	#5	160	Table 3

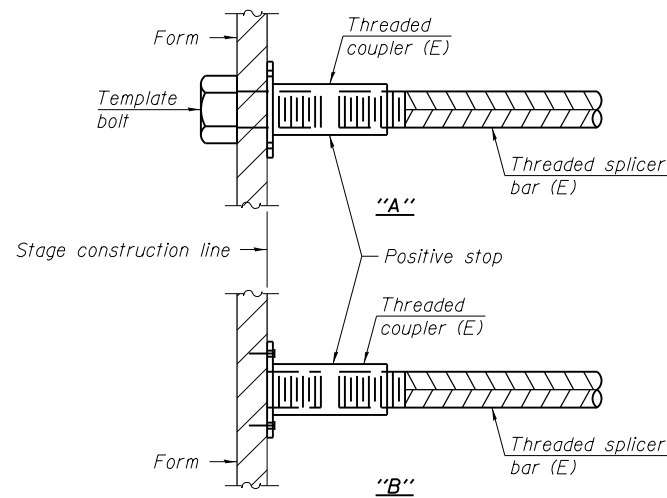

INSTALLATION AND SETTING METHODS

"A" : Set bar splicer assembly by means of a template bolt.
 "B" : Set bar splicer assembly by nailing to wood forms or cementing to steel forms.
 (E) : Indicates epoxy coating.

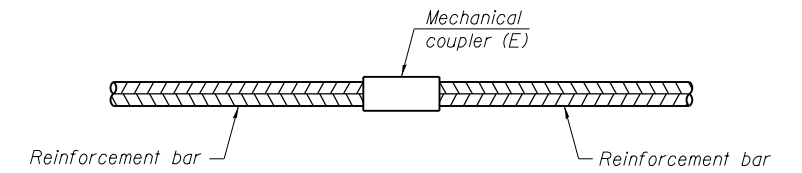

STANDARD MECHANICAL SPLICER

Location	Bar size	No. assemblies required

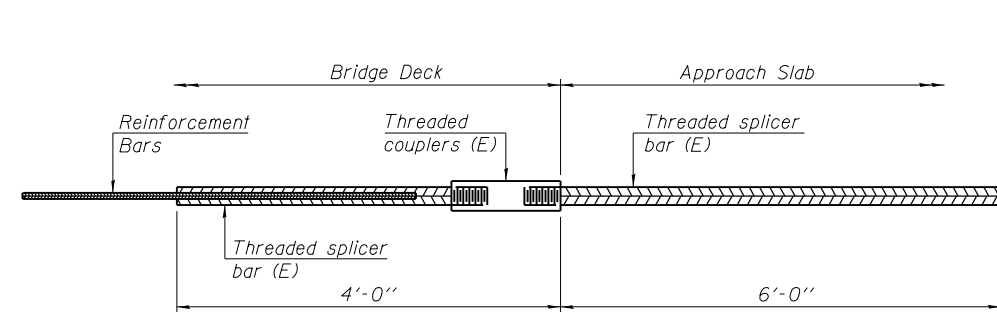

BAR SPLICER ASSEMBLY FOR #5 BAR ON INTEGRAL OR SEMI-INTEGRAL ABUTMENTS

No. required =

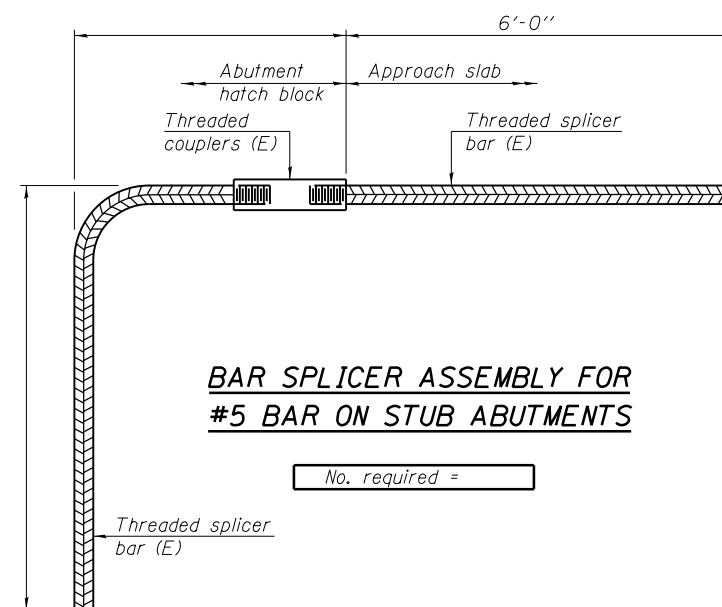

BAR SPLICER ASSEMBLY FOR #5 BAR ON STUB ABUTMENTS

No. required =

NOTES

Splicer bars shall be deformed with threaded ends and have a minimum 60 ksi yield strength.
 All reinforcement shall be lapped and tied to the splicer bars.
 Bar splicer assemblies shall be epoxy coated according to the requirements for reinforcement bars. See Section 508 of the Standard Specifications.
 See special provision for Mechanical Splicers.
 See approved list of bar splicer assemblies and mechanical splicers for alternatives.

BSD-1 7-1-10
 BENTON & ASSOCIATES, INC.

FILE NAME = P:\10e2166-2\Design\Plans\082-0164-76022-006-Splicer.dgn	USER NAME =	DESIGNED - MBH	REVISED - 10/3/13
		CHECKED - SJH	REVISED -
	PLOT SCALE =	DRAWN - MBH	REVISED -
	PLOT DATE =	CHECKED - SJH	REVISED -

STATE OF ILLINOIS
 DEPARTMENT OF TRANSPORTATION

BAR SPLICER ASSEMBLY AND MECHANICAL SPLICER DETAILS
 STRUCTURE NO. 082-0164 & 082-0165

SHEET NO. 10 OF 10 SHEETS

F.A.I. RTE.	SECTION	COUNTY	TOTAL SHEETS	SHEET NO.
64	82-3HB-1	ST. CLAIR	208	186
CONTRACT NO. 76022				
FED. ROAD DIST. NO. 8 ILLINOIS FED. AID PROJECT				

INDEX OF SHEETS

General Plan & Elevation	1
Staging	2-3
Temporary Concrete Barrier For Stage Construction	4
Deck Repairs	5
Concrete Removal & Replacement	6-7
Preformed Joint Strip Seal	8
Substructure Repairs	9
Bearing Details	10
Bar Splicer Assembly Details	11

GENERAL NOTES

- All new structural steel shall conform to AASHTO Classification M270 Gr. 36 unless otherwise noted.
- Fasteners shall be AASHTO M164 Type 1, mechanically galvanized bolts (in painted areas and M164 Type 3 in unpainted areas). Bolts $\frac{7}{8}$ " ϕ , holes $\frac{15}{16}$ " ϕ , unless otherwise noted.
- No field welding is permitted except as specified in the contract documents.
- Reinforcement bars designated (E) shall be epoxy coated.
- Prior to pouring the new concrete deck, all heavy or loose rust, loose mill scale, and other loose or potentially detrimental foreign material shall be removed from the surfaces in contact with concrete. Tightly adhered paint may remain unless otherwise noted. Removal shall be accomplished by methods that will not damage the steel and the cost will be included in the pay item covering removal of the existing concrete.
- As directed by the Engineer, existing construction accessories welded to the top flange of beams and girders shall be removed. The weld areas shall be ground flush and inspected for cracks using magnetic particle testing (MT) or dye penetrant testing (PT) by qualified personnel approved by the Engineer. Any cracks that can not be removed by grinding $\frac{1}{4}$ in. deep shall be identified and reported to the Bureau of Bridges and Structures for further disposition. The cost of removing welded accessories, grinding and inspecting weld areas and grinding cracks will be paid for according to Article 109.04 of the Standard Specifications.
- Plan dimensions and details relative to existing plans are subject to nominal construction variations. The Contractor shall field verify existing dimensions and details affecting new construction and make necessary approved adjustments prior to construction or ordering of materials. Such variations shall not be cause for additional compensation for a change in scope of the work, however, the Contractor will be paid for the quantity actually furnished at the unit price bid for the work.
- Existing reinforcement bars extending into the removal area shall be cleaned, straightened and incorporated into the new construction. Any reinforcement bars that are damaged during concrete removal shall be replaced with an approved bar splicer or anchorage system. Cost included with Concrete Removal.
- Joint openings shall be adjusted according to Article 520.04 of the Standard Specs. when the deck is poured at an ambient temperature other than 50° F.
- Areas of deck repairs shown are estimated. The Engineer shall show actual locations of deck repairs on As-built Plans.
- All structural steel shall be shop painted with the inorganic zinc rich primer per AASHTO M300, Type 1. Color to match existing. Cost included with Furnishing and Erecting Structural Steel.
- The existing structural steel contains lead. The contractor shall take appropriate precautions to deal with the presence of lead on this project.
- Existing structural steel that will be in contact with new structural steel shall be cleaned and painted prior to erection as required by the Special Provisions "Cleaning & Painting Contact Surface Areas of Existing Steel Structures".

TOTAL BILL OF MATERIAL

ITEM	UNIT	QUANTITY
Concrete Removal	Cu. Yd.	24.7
Concrete Superstructure	Cu. Yd.	24.5
Jack and Remove Existing Bearings	Each	14
Reinforcement Bars, Epoxy Coated	Pound	3460
Preformed Joint Strip Seal	Foot	182
Elastomeric Bearing Assembly, Type II	Each	14
Anchor Bolts, 1 1/4"	Each	28
Furnishing and Erecting Structural Steel	Pound	1740
Protective Shield	Sq. Yd.	34
Bar Splicers	Each	48
Structural Repair of Concrete (Depth <= 5")	Sq. Ft.	325
Slope Wall Removal	Sq. Yd.	964
Stone Riprap, Class A4	Sq. Yd.	964
Bridge Sidewalk Repair	Sq. Ft.	24
Joint or Crack Routing (PC Concrete Pavement and Shoulder)	Ft.	266
Joint or Crack Filling	Pound	2200

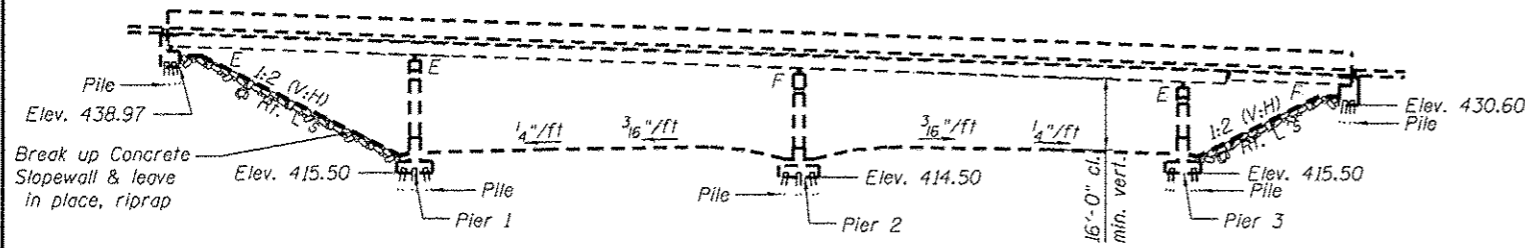

ELEVATION

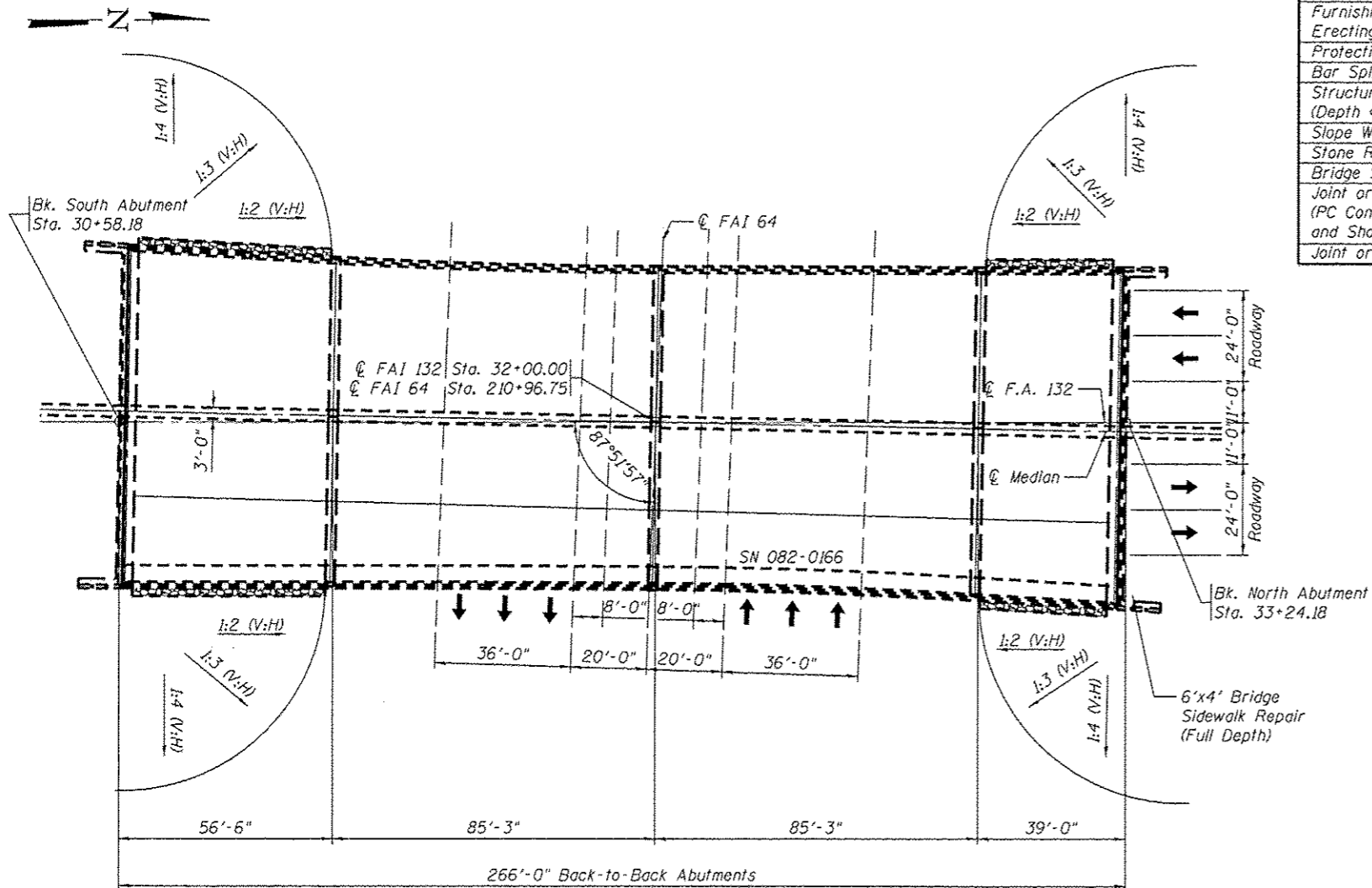

TOP PLAN

ORIGINAL DESIGN STRESSES

FIELD UNITS
 $f'_c = 1,400$ psi (Piers and Superstructure)
 $f'_c = 1,000$ psi (Substructure w/ Earth Pressure)
 $f_y = 20,000$ psi (Reinforcement)
 $f_y = 20,000$ psi (Structural Steel A36)
 $n = 10$
 $N = 75$ psi

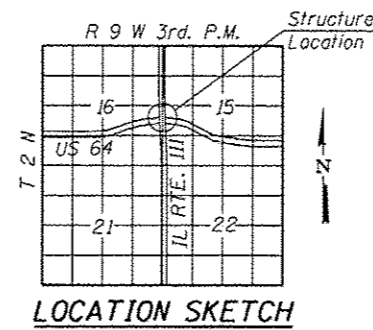

LOCATION SKETCH

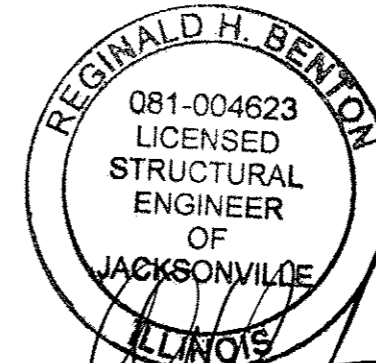

Reginald H. Benton
 8/20/13 Exp 11/30/14

GENERAL PLAN & ELEVATION
F.A. 132 (IL III) OVER
F.A.I. RTE. 64 - SEC. 82-3HB-1
ST. CLAIR COUNTY
US 64 STA. 210+96.75
IL III STA. 32+00.00

BENTON & ASSOCIATES, INC.

FILE NAME = P:\102166-2\Design\Plans\082-0166
 0820166-76022-081-GPE.dgn

USER NAME =	DESIGNED = MBH	REVISED =
PLOT SCALE =	CHECKED = SJH	REVISED =
PLOT DATE =	DRAWN = MBH	REVISED =
	CHECKED = SJH	REVISED =

STATE OF ILLINOIS
DEPARTMENT OF TRANSPORTATION

GENERAL PLAN & ELEVATION
STRUCTURE NO. 082-0166

SHEET NO. 1 OF 11 SHEETS

F.A.I. RTE.	SECTION	COUNTY	TOTAL SHEETS	SHEET NO.
64	82-3HB-1	ST. CLAIR	208	187
CONTRACT NO. 76022				
FED. ROAD DIST. NO. 8 (ILLINOIS) FED. AID PROJECT				

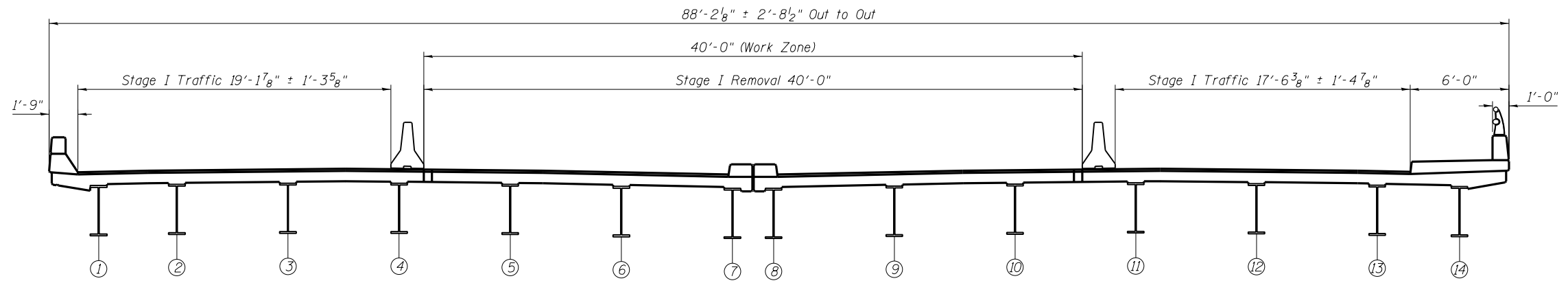

SN 082-0166 CROSS SECTION
(Looking North)

STAGE I REMOVAL

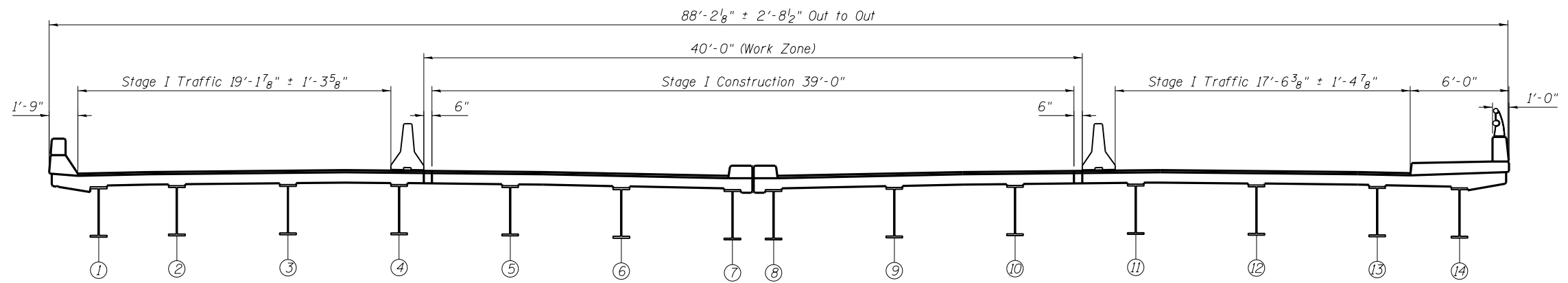

SN 082-0166 CROSS SECTION
(Looking North)

STAGE I CONSTRUCTION

BENTON & ASSOCIATES, INC.

FILE NAME = P:\10e2166-2\ Design\
Plans\ 082-0166
0820166-76022-002-Staging.dgn

USER NAME =
PLOT SCALE =
PLOT DATE =

DESIGNED - MBH
CHECKED - SJH
DRAWN - MBH
CHECKED - SJH

REVISED - _____
REVISED - _____
REVISED - _____
REVISED - _____

**STATE OF ILLINOIS
DEPARTMENT OF TRANSPORTATION**

**STAGING SECTIONS
STRUCTURE NO. 082-0166**

SHEET NO. 2 OF 11 SHEETS

F.A.I. RTE.	SECTION	COUNTY	TOTAL SHEETS	SHEET NO.
64	82-3HB-1	ST. CLAIR	208	188
CONTRACT NO. 76022				
FED. ROAD DIST. NO. 8 ILLINOIS FED. AID PROJECT				

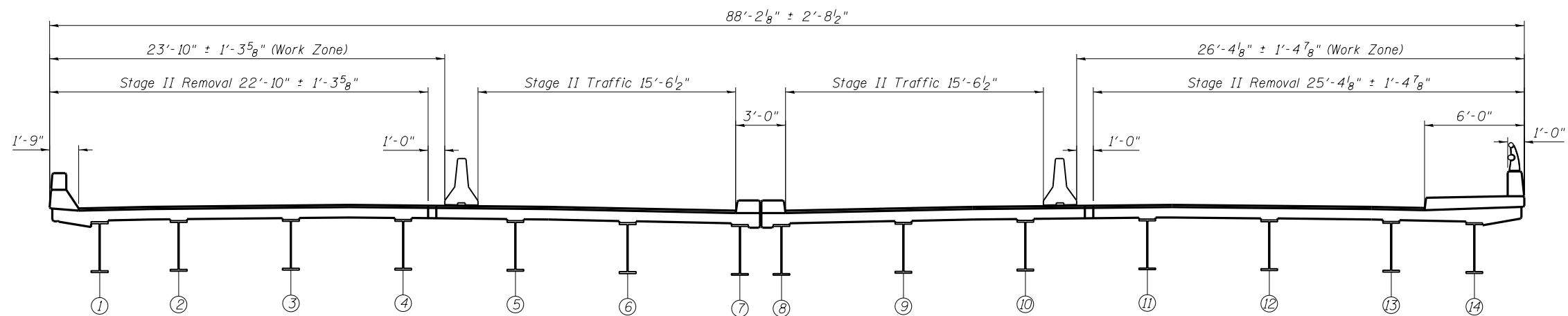

SN 082-0166 CROSS SECTION
(Looking North)

STAGE II REMOVAL

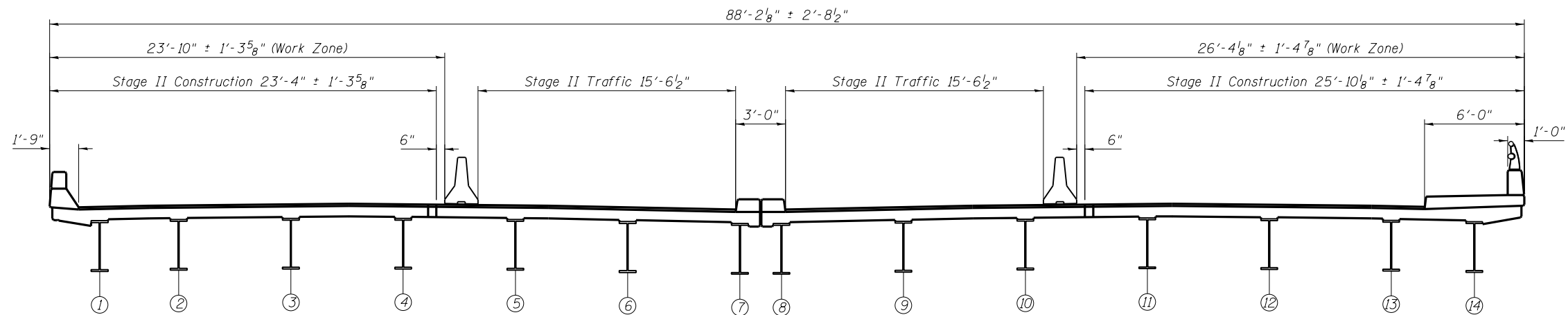

SN 082-0166 CROSS SECTION
(Looking North)

STAGE II CONSTRUCTION

BENTON & ASSOCIATES, INC.

FILE NAME = P:\10e2166-2\ Design\ Plans\ 082-0166	USER NAME =	DESIGNED - MBH	REVISED - 10/3/13
0820166-76022-002-Staging.dgn	PLOT SCALE =	CHECKED - SJH	REVISED - _____
	PLOT DATE =	DRAWN - MBH	REVISED - _____
		CHECKED - SJH	REVISED - _____

**STATE OF ILLINOIS
DEPARTMENT OF TRANSPORTATION**

**STAGING SECTIONS
STRUCTURE NO. 082-0166**

SHEET NO. 3 OF 11 SHEETS

F.A.I. RTE.	SECTION	COUNTY	TOTAL SHEETS	SHEET NO.
64	82-3HB-1	ST. CLAIR	208	189
CONTRACT NO. 76022				
FED. ROAD DIST. NO. 8 ILLINOIS FED. AID PROJECT				

When "A" is 3'-6" or less, the temporary concrete barrier shall be anchored to the new slab according to Detail I or Detail II. No anchorage is required when "A" is greater than 3'-6".

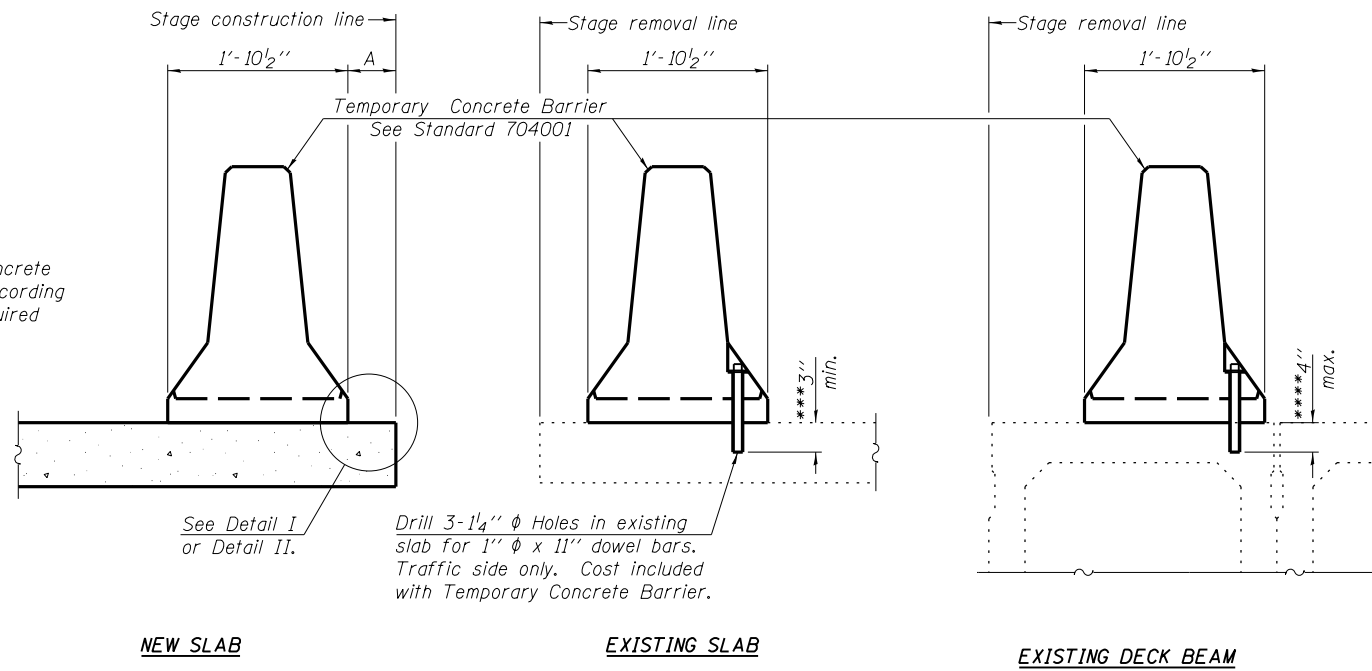

SECTIONS THRU SLAB OR DECK BEAM

NOTES

Detail I - With Bar Splicer or Couplers:
Connect one (1) 1" x 7" x "W" steel \bar{r} to the top layer of couplers with 2- $\frac{5}{8}$ " ϕ bolts screwed to coupler at approximate \bar{c} of each barrier panel.

Detail II - With Extended Reinforcement Bars:
Connect one (1) 1" x 7" x "W" steel \bar{r} to the concrete slab or concrete wearing surface with 2- $\frac{5}{8}$ " ϕ Expansion Anchors or cast in place inserts spaced between the top layer of reinforcement at approximate \bar{c} of each barrier panel.

Cost of anchorage is included with Temporary Concrete Barrier. The 1" x 7" x "W" plate shall not be removed until stage II construction forms and all reinforcement bars are in place and the concrete is ready to be placed.

*** Dimension shown is minimum required embedment into concrete. If hot-mix asphalt wearing surface is present, minimum embedment shall be in addition to wearing surface depth.

**** If existing deck beam is to remain in place after stage construction, embedment shall only be into wearing surface and not into existing deck beam concrete.

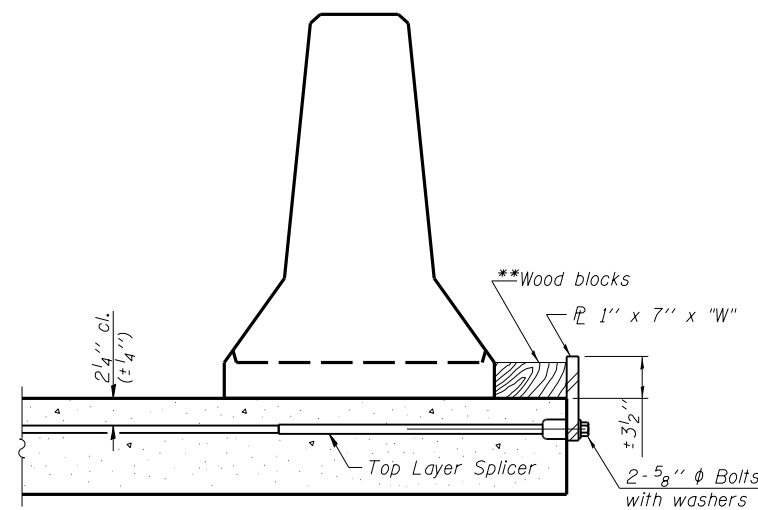

DETAIL I

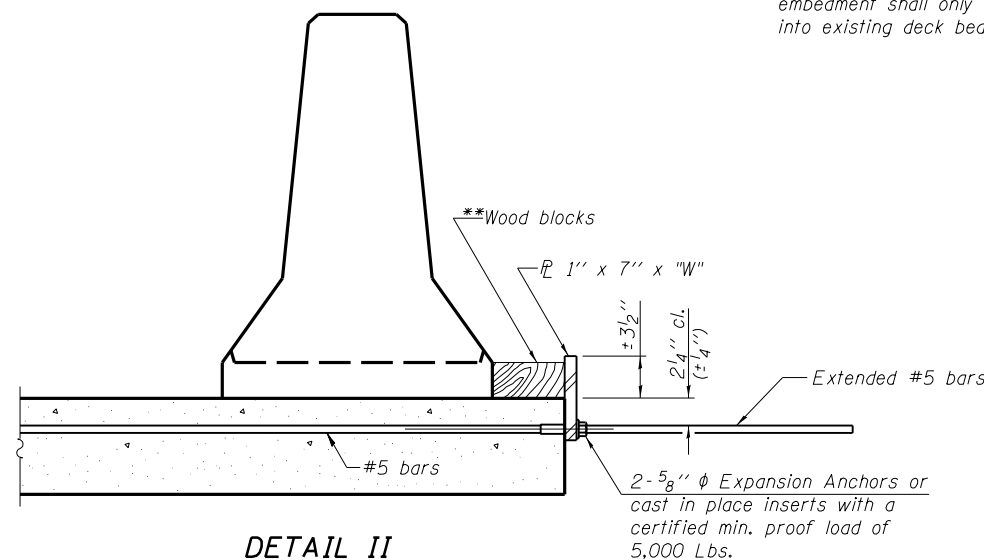

DETAIL II

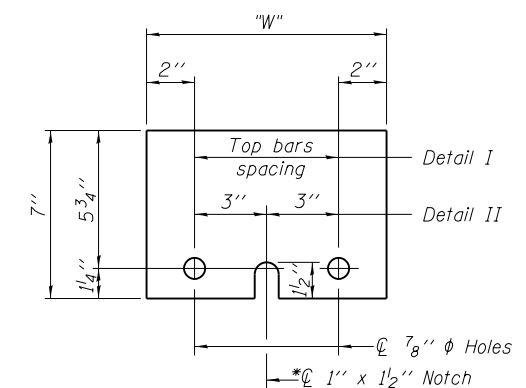

STEEL RETAINER \bar{r} 1" x 7" x "W"

* Required only with Detail II

** Wood blocks may be omitted when required to provide minimum stage traffic lane width. When the wood blocks are omitted, the concrete barrier shall be in direct contact with the steel retainer plate.

"W" = Top bars spacing + 4"

R-27 7-1-10
BENTON & ASSOCIATES, INC.

FILE NAME = P:\10e2166-2\Design\	USER NAME =	DESIGNED - MBH	REVISED -
Plans\082-0166 \		CHECKED - SJH	REVISED -
0820166-76022-003-Barrier.dgn	PLOT SCALE =	DRAWN - MBH	REVISED -
	PLOT DATE =	CHECKED - SJH	REVISED -

STATE OF ILLINOIS
DEPARTMENT OF TRANSPORTATION

TEMPORARY CONCRETE BARRIER FOR STAGE CONSTRUCTION
STRUCTURE NO. 082-0166

SHEET NO. 4 OF 11 SHEETS

F.A.I. RTE.	SECTION	COUNTY	TOTAL SHEETS	SHEET NO.
64	82-1HB1-2	ST. CLAIR	208	190
CONTRACT NO. 76022				
FED. ROAD DIST. NO. 8 ILLINOIS FED. AID PROJECT				

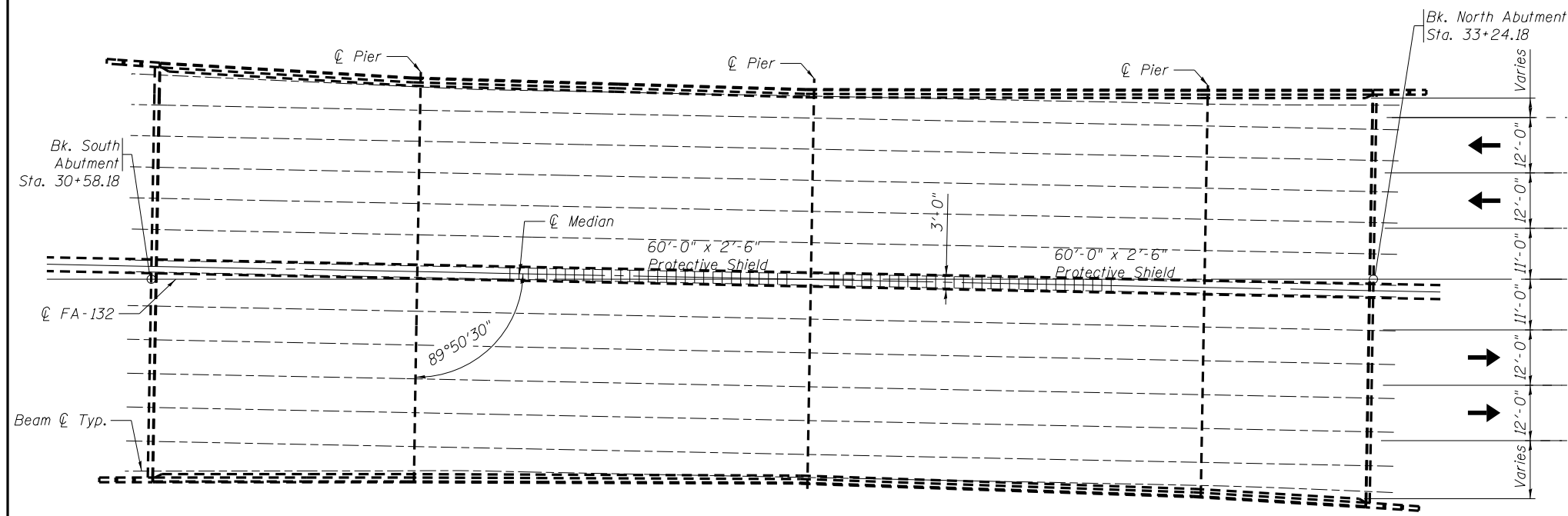

DECK PLAN

Notes:
 Part of the underside deck is obstructed from view. Additional damage to the underside deck may exist. Contractor to field verify amount of damage and repair what is needed. Contractor to confirm all related quantities.

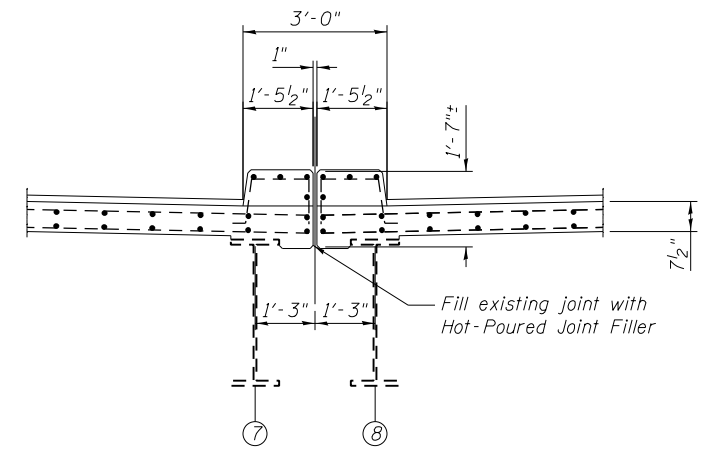

MEDIAN JOINT REPLACEMENT

BILL OF MATERIAL

ITEM	UNIT	QUANTITY
Protective Shield	Sq. Yd.	34
Joint or Crack Routing (PC Concrete Pavement and Shoulder)	Ft.	266.0
Joint or Crack Filling	Pound	2200

BENTON & ASSOCIATES, INC.

FILE NAME = P:\10e2166-2\Design\Plans\082-0166	USER NAME =	DESIGNED - MBH	REVISED -
0820166-76022-004-Deck.dgn	PLOT SCALE =	CHECKED - SJH	REVISED -
	PLOT DATE =	DRAWN - MBH	REVISED -
		CHECKED - SJH	REVISED -

**STATE OF ILLINOIS
 DEPARTMENT OF TRANSPORTATION**

**DECK REPAIRS
 STRUCTURE NO. 082-0166**

SHEET NO. 5 OF 11 SHEETS

F.A.I. RTE.	SECTION	COUNTY	TOTAL SHEETS	SHEET NO.
64	82-3HB-1	ST. CLAIR	208	191
CONTRACT NO. 76022				
FED. ROAD DIST. NO. 8 ILLINOIS FED. AID PROJECT				

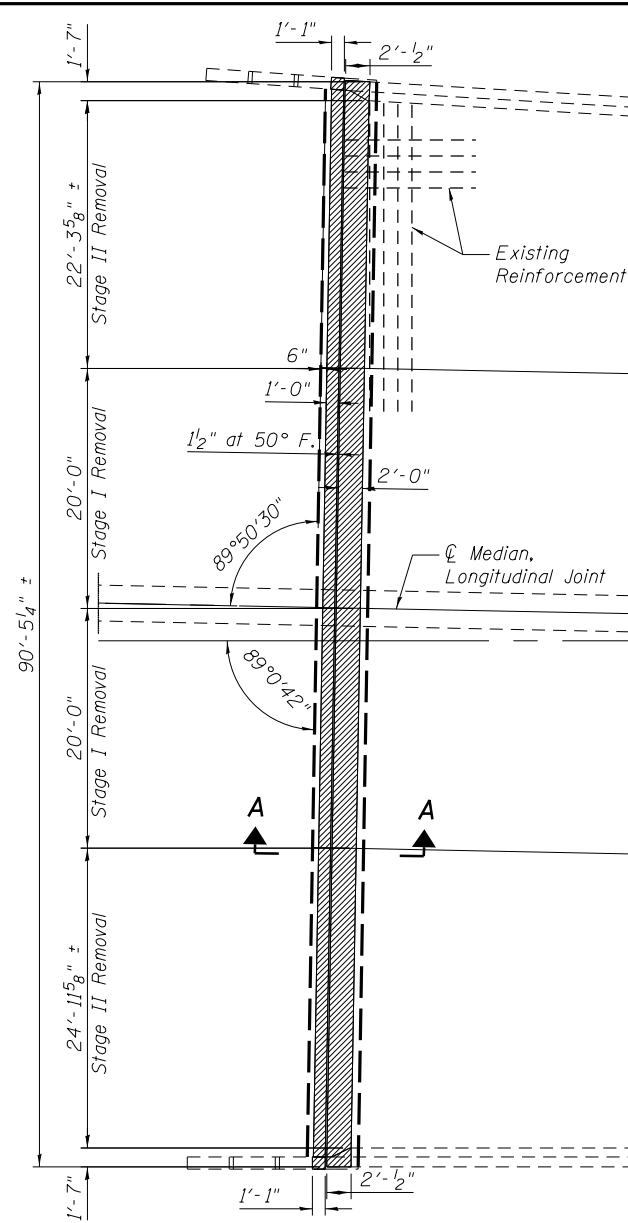

CONCRETE REMOVAL
(South Abut. shown)

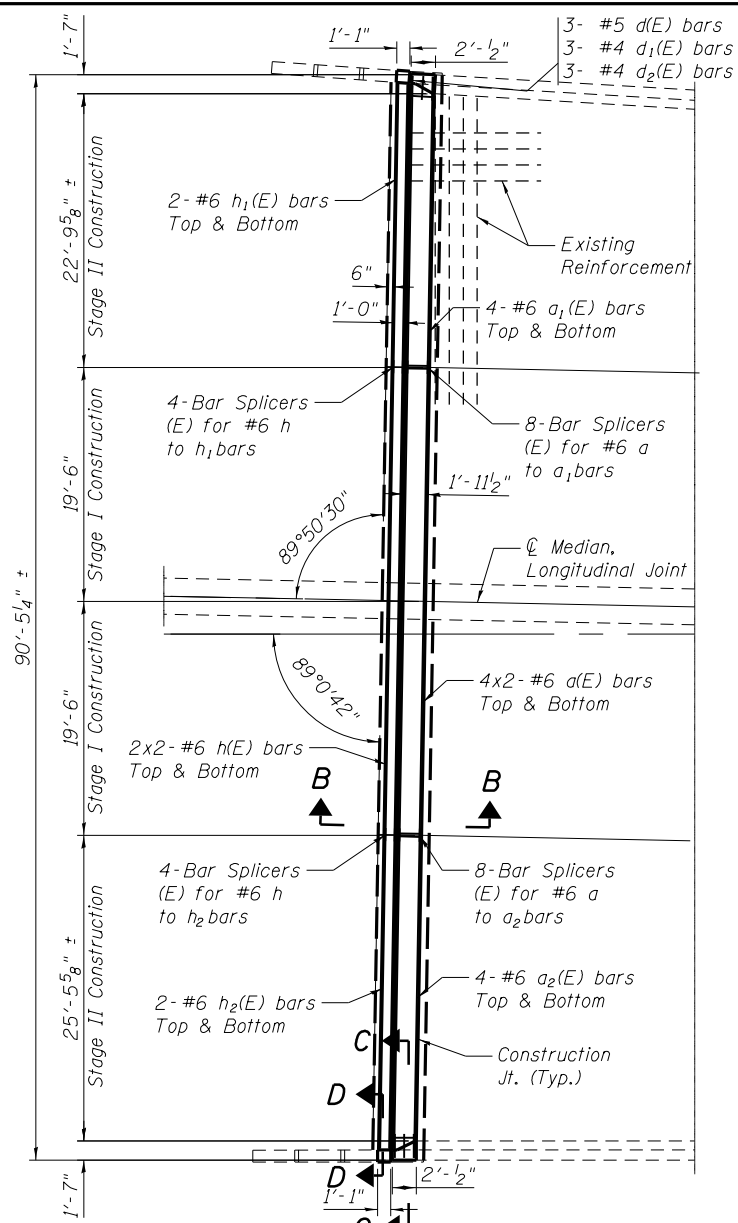

CONCRETE REPLACEMENT
(South Abut. shown)

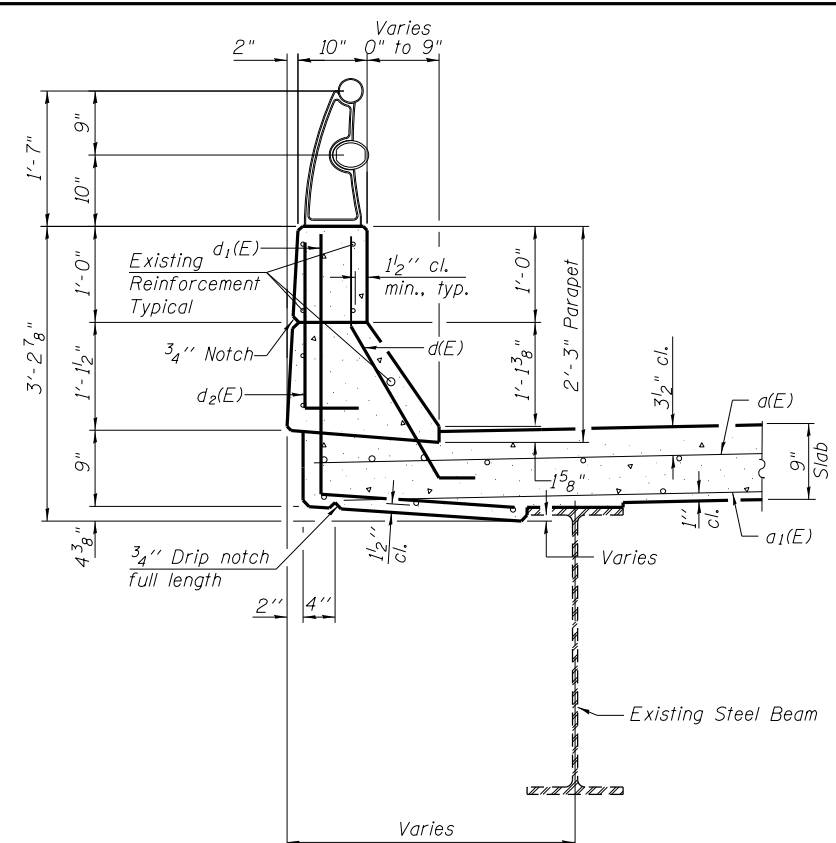

SECTION C-C

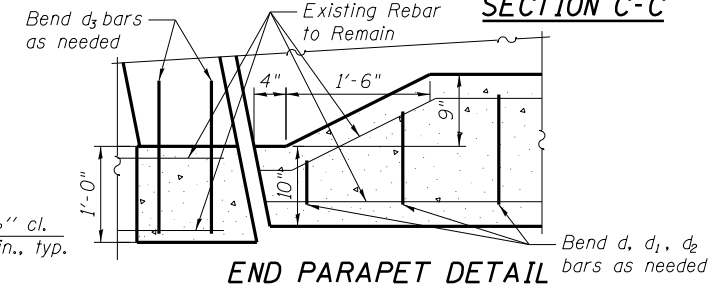

END PARAPET DETAIL

**SUPERSTRUCTURE
BILL OF MATERIAL**

Bar	No.	Size	Length	Shape
a(E)	16	#6	20'-11"	—
a1(E)	8	#6	24'-1"	—
a2(E)	8	#6	26'-9"	—
d(E)	6	#5	3'-5"	L
d1(E)	3	#4	4'-5"	L
d2(E)	3	#4	2'-5"	L
d3(E)	2	#4	5'-9"	L
d4(E)	3	#4	5'-2"	L
d5(E)	2	#4	6'-6"	L
d6(E)	3	#4	3'-2"	L
h(E)	8	#6	20'-11"	—
h1(E)	4	#6	23'-5"	—
h2(E)	4	#6	26'-0"	—
Bar Splicers		Each	24	
Reinforcement Bars, Epoxy Coated		Pound	1730	
Concrete Superstructure		Cu. Yds.	12.3	
Concrete Removal		Cu. Yds.	12.4	
Preformed Strip Seal		Foot	91	

Bars indicated thus 4x2 -#6 etc. indicates 4 lines of bars with 2 lengths per line.

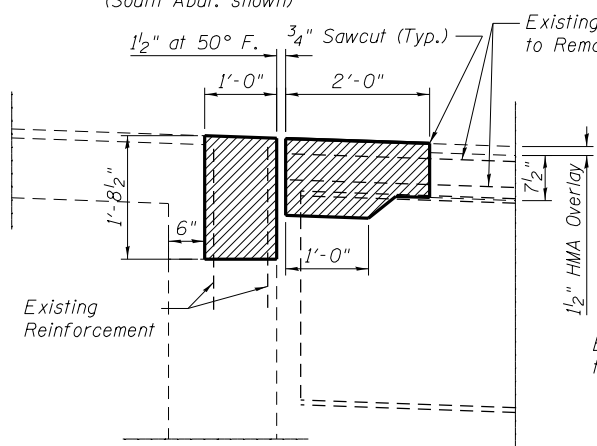

SECTION A-A

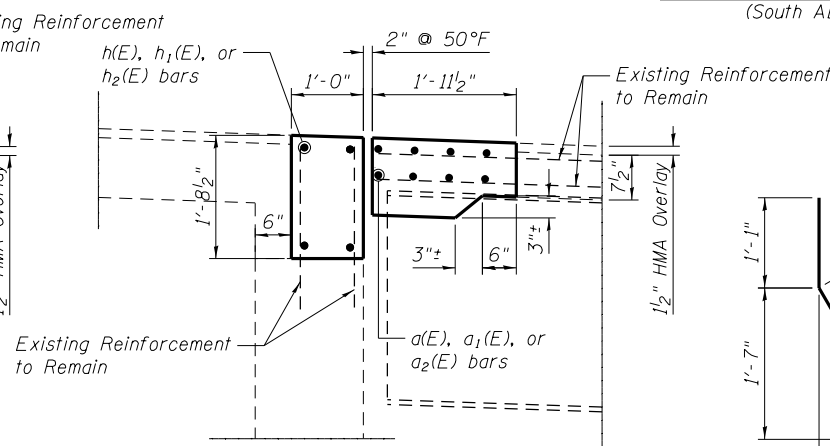

SECTION B-B

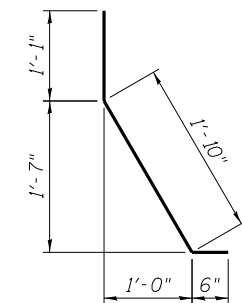

BAR d(E)

MINIMUM BAR LAP
#6 bar = 3'-1"

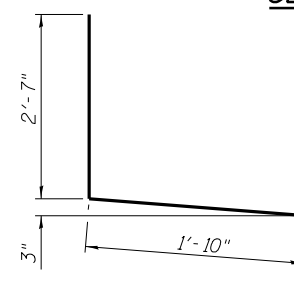

BAR d1(E)

SECTION D-D

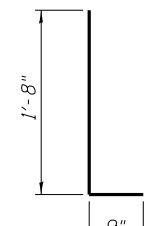

BAR d2(E)

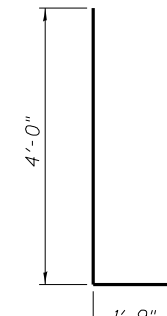

BAR d3(E)

BENTON & ASSOCIATES, INC.

FILE NAME = P:\10e2166-2\ Design\	USER NAME =	DESIGNED - MBH	REVISED - 10/3/13
Plans\ 082-0166		CHECKED - SJH	REVISED -
0820166-76022-005-Joint.dgn	PLOT SCALE =	DRAWN - MBH	REVISED -
	PLOT DATE	CHECKED - SJH	REVISED -

**STATE OF ILLINOIS
DEPARTMENT OF TRANSPORTATION**

**CONCRETE REMOVAL & REPLACEMENT
STRUCTURE NO. 082-0166**

SHEET NO. 6 OF 11 SHEETS

F.A.I. RTE.	SECTION	COUNTY	TOTAL SHEETS	SHEET NO.
64	82-3HB-1	ST. CLAIR	208	192
				CONTRACT NO. 76022
FED. ROAD DIST. NO. 8 ILLINOIS FED. AID PROJECT				

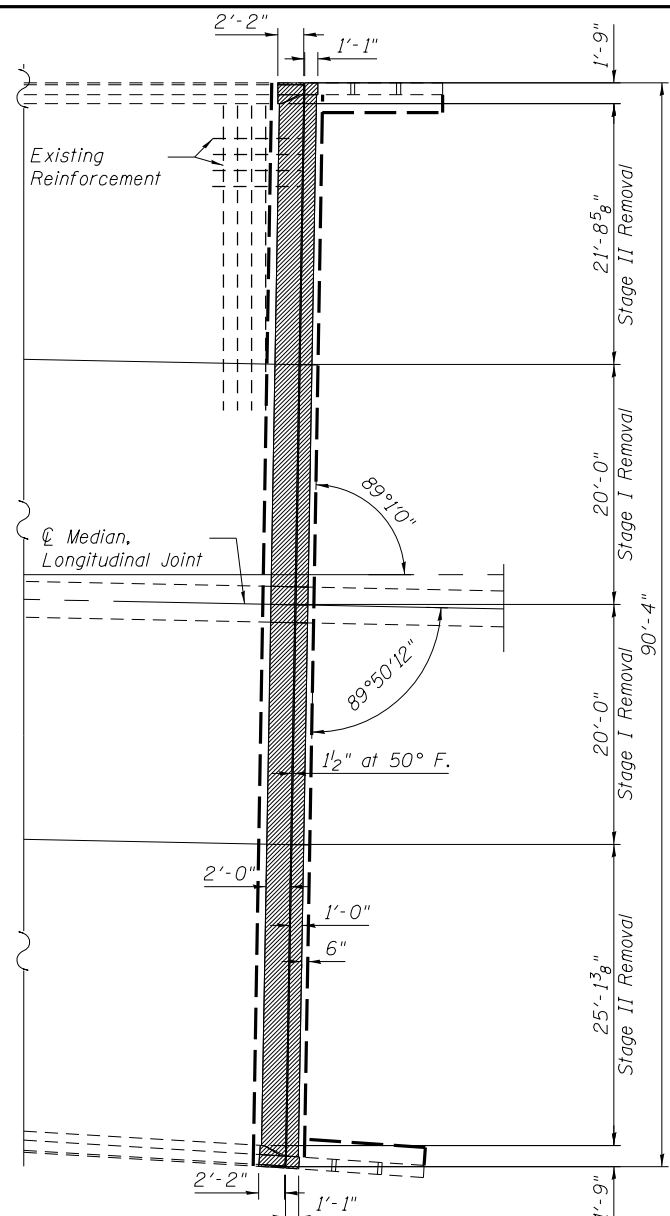

CONCRETE REMOVAL
(North Abut. shown)

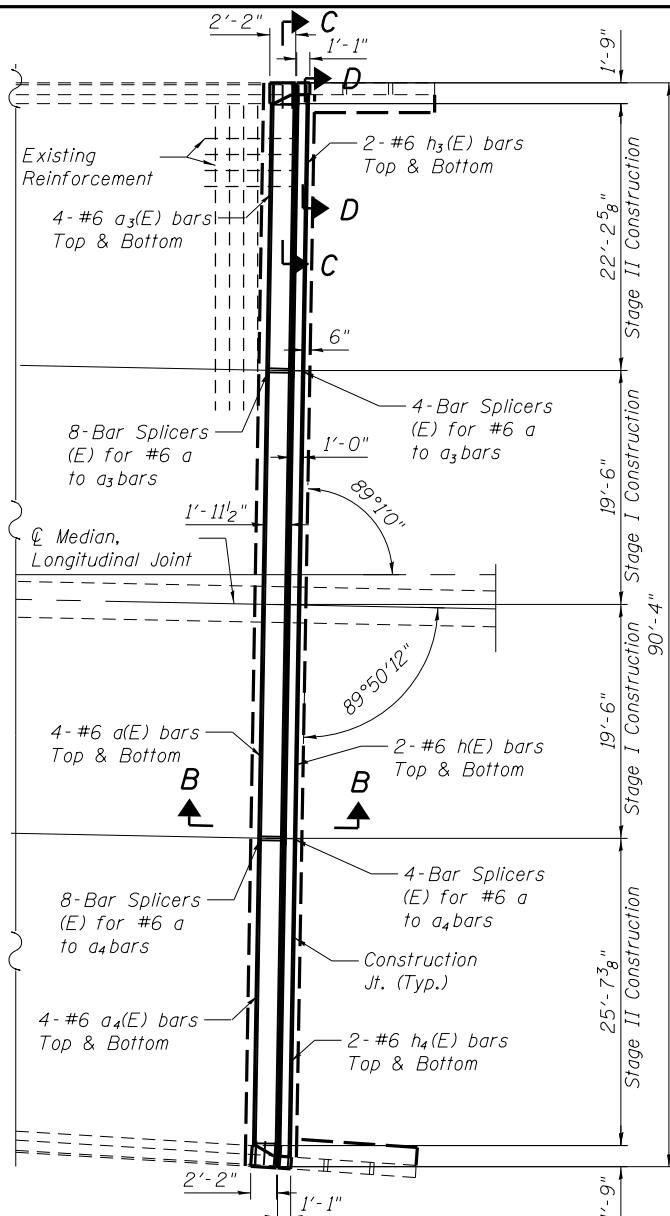
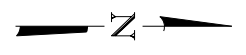

CONCRETE REPLACEMENT
(North Abut. shown)

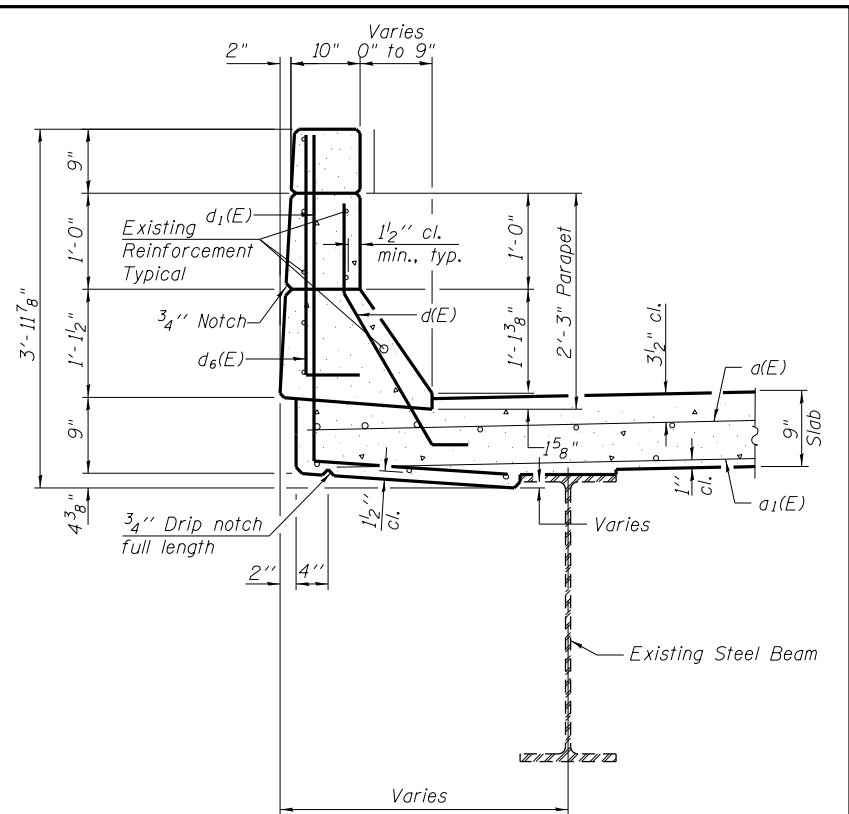

SECTION C-C

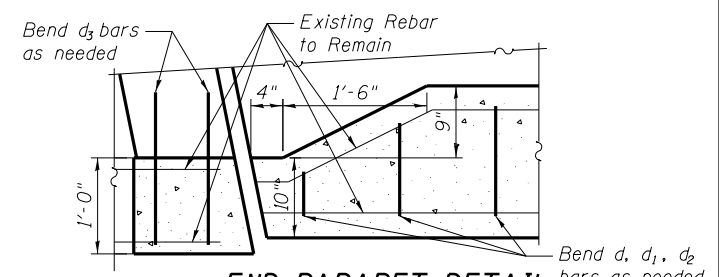

END PARAPET DETAIL

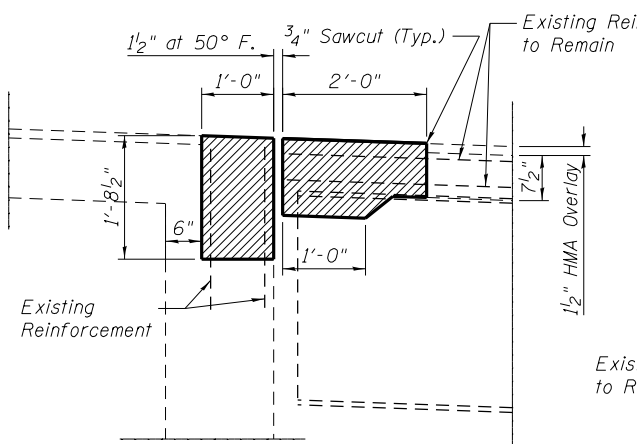

SECTION A-A

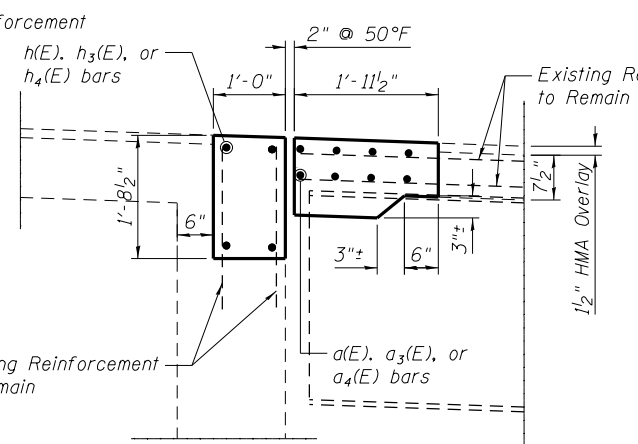

SECTION B-B

MINIMUM BAR LAP
#6 bar = 3'-1"

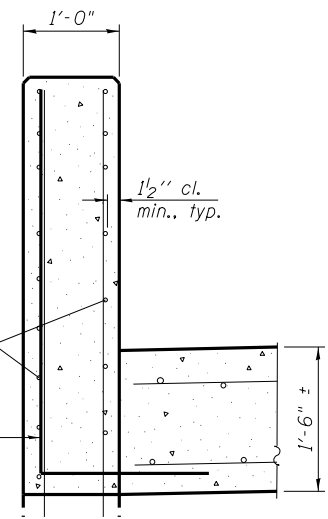

SECTION D-D

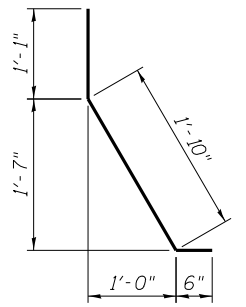

BAR d(E)

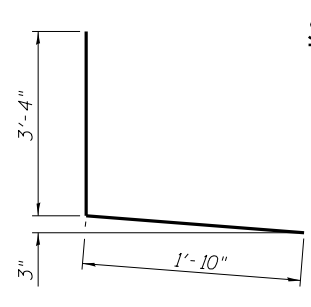

BAR d4(E)

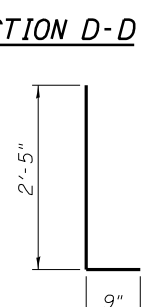

BAR d6(E)

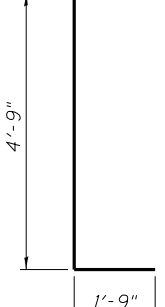

BAR d5(E)

SUPERSTRUCTURE BILL OF MATERIAL

Bar	No.	Size	Length	Shape
a(E)	16	#6	20'-11"	—
a3(E)	8	#6	23'-8"	—
a4(E)	8	#6	27'-1"	—
d(E)	6	#5	3'-5"	┘
d1(E)	3	#4	4'-5"	┘
d2(E)	3	#4	2'-5"	┘
d3(E)	2	#4	5'-9"	┘
d4(E)	3	#4	5'-2"	┘
d5(E)	2	#4	6'-6"	┘
d6(E)	3	#4	3'-2"	┘
h(E)	8	#6	20'-11"	—
h3(E)	4	#6	22'-9"	—
h4(E)	4	#6	26'-3"	—
Bar Splicers			Each	24
Reinforcement Bars, Epoxy Coated			Pound	1730
Concrete Superstructure			Cu. Yds.	12.2
Concrete Removal			Cu. Yds.	12.3
Preformed Strip Seal			Foot	91

Bars indicated thus 4x2 -#6 etc. indicates 4 lines of bars with 2 lengths per line.

BENTON & ASSOCIATES, INC.

FILE NAME = P:\10e2166-2\Design\	USER NAME =	DESIGNED - MBH	REVISED - 10/3/13
Plans\082-0166		CHECKED - SJH	REVISED -
0820166-76022-006-Joint.dgn	PLOT SCALE =	DRAWN - MBH	REVISED -
	PLOT DATE	CHECKED - SJH	REVISED -

STATE OF ILLINOIS DEPARTMENT OF TRANSPORTATION

CONCRETE REMOVAL & REPLACEMENT STRUCTURE NO. 082-0166

SHEET NO. 7 OF 11 SHEETS

F.A.I. RTE.	SECTION	COUNTY	TOTAL SHEETS	SHEET NO.
64	82-3HB-1	ST. CLAIR	208	193
CONTRACT NO. 76022				
FED. ROAD DIST. NO. 8 ILLINOIS FED. AID PROJECT				

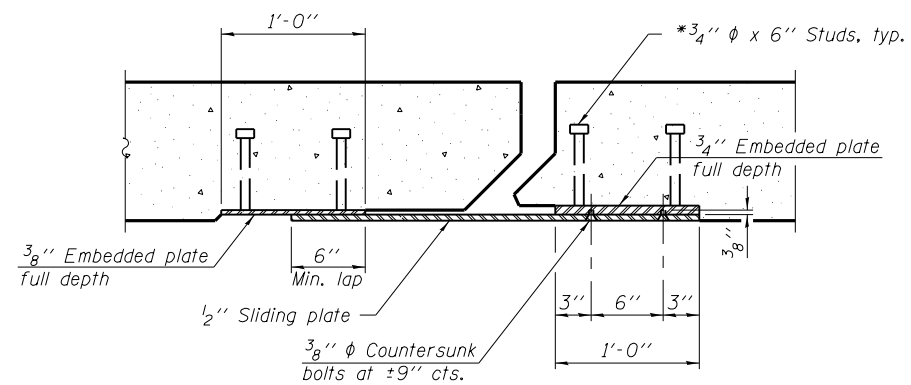
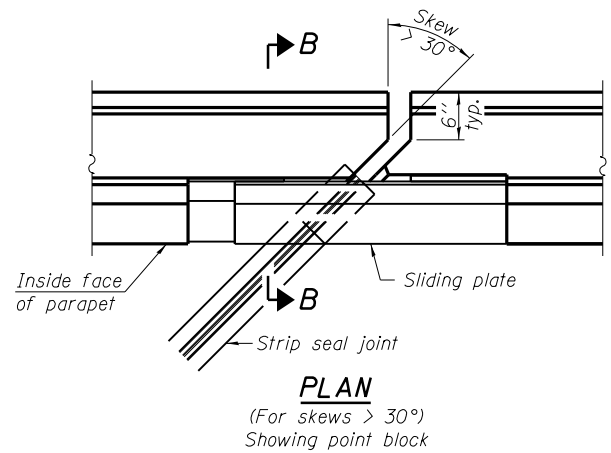
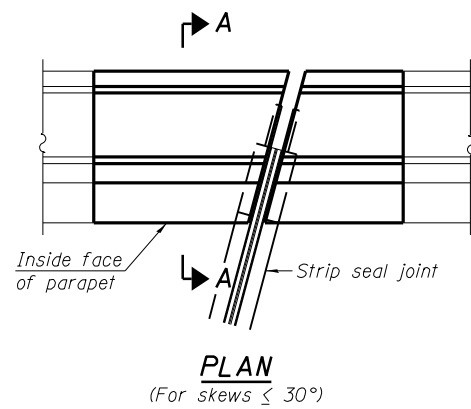

SECTION C-C

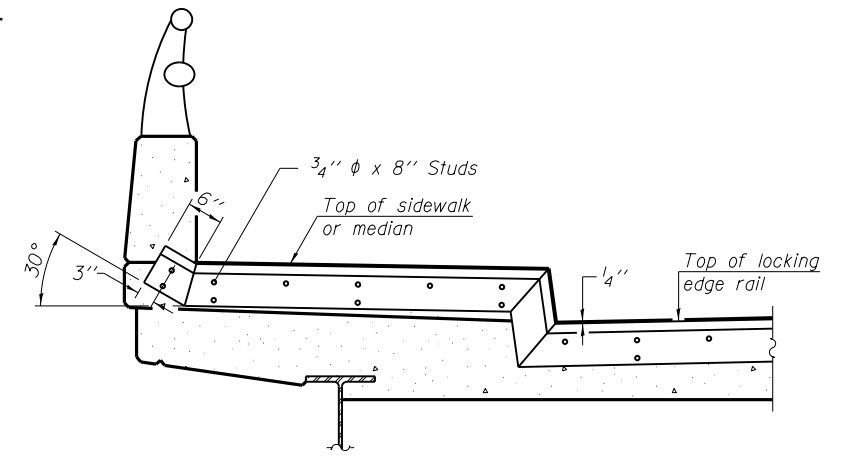

TYPICAL END TREATMENT AT SIDEWALK OR MEDIAN

Shorter plates with a single row of studs at 12" cts. may be necessary on medians which are shallower than 9". See manufacturer's recommendation.

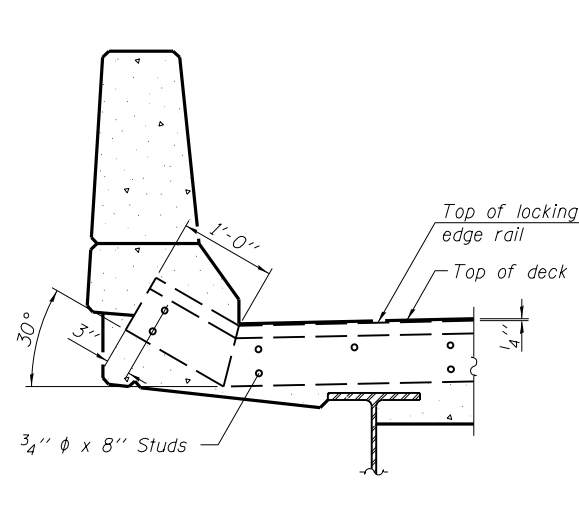

SECTION A-A

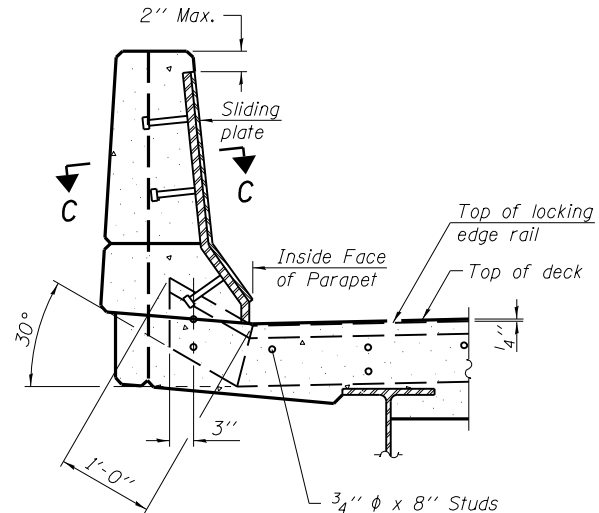

SECTION B-B

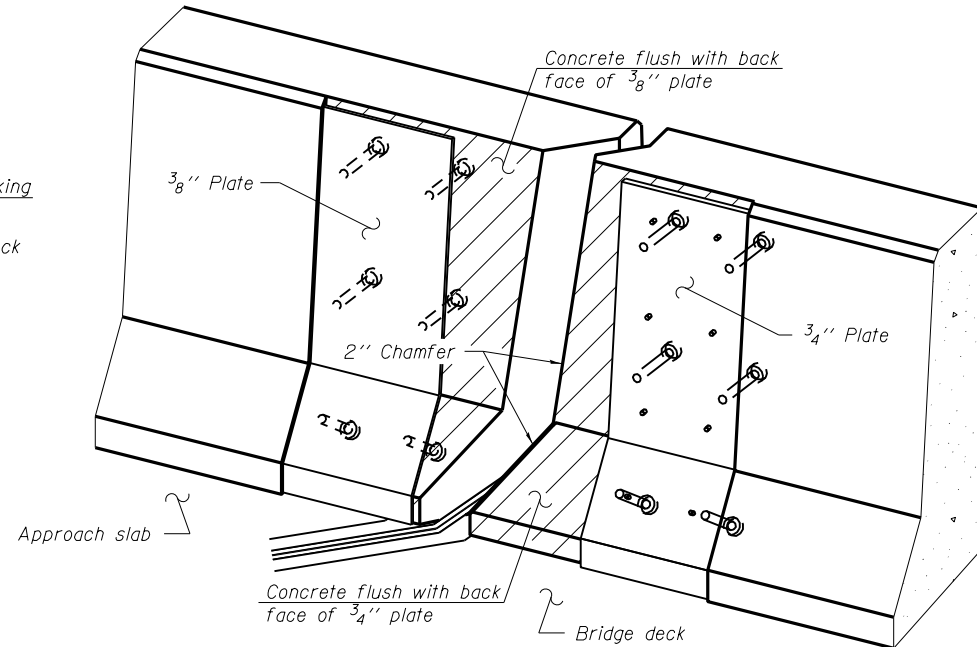

TRIMETRIC VIEW (Showing back plates only)

Notes:

The strip seal shall be made continuous and shall have a minimum thickness of 1/4". The configuration of the strip seal shall match the configuration of the Locking Edge Rails. Open or "webbed" strip seal gland configurations are not permitted. The gland shall be sized for a maximum rated movement of 4 inches.

The Locking Edge Rails depicted are conceptual only, except for the minimum dimensions shown. The actual configuration of the Locking Edge Rails and matching strip seal may vary from manufacturer to manufacturer. Flanged edge rails will not be allowed. Locking Edge Rails may be spliced at slope discontinuities.

The manufacturer's recommended installation methods shall be followed.

The joint opening and deck dimensions detailed on the superstructure are based on a rolled rail expansion joint. If the Contractor elects to use the welded rail expansion joint, the opening and deck dimensions shall be modified according to the dimensions detailed on this sheet. Required modifications shall be made at no additional cost to the State.

All steel components shall be galvanized after fabrication according to Article 520.03 of the Standard Specifications.

Maximum space between rail segments at stage lines shall be 3/16", sealed with a suitable sealant.

Parapet plates and anchorage studs for skews > 30 degrees included in the cost of Preformed Joint Strip Seal.

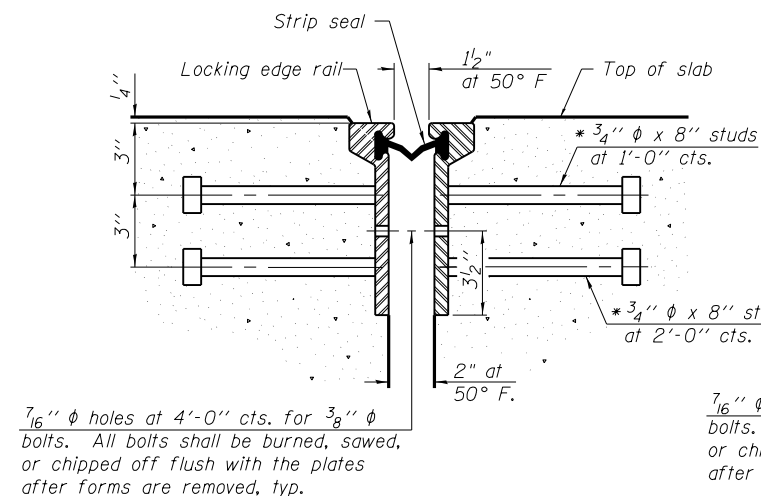

SECTION THRU ROLLED RAIL JOINT

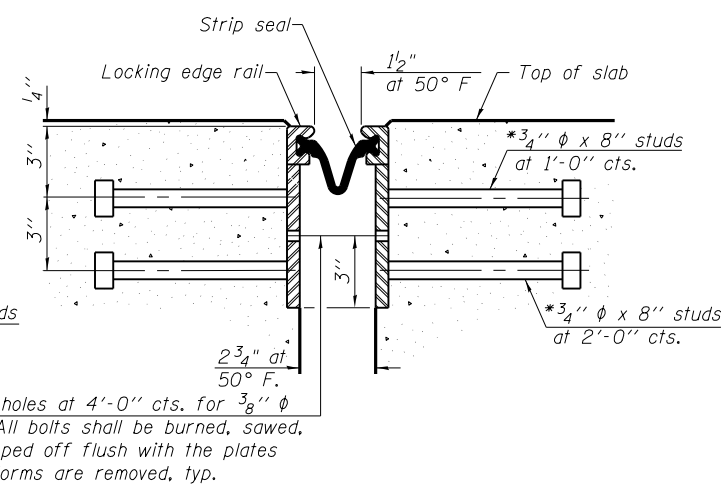

SECTION THRU WELDED RAIL JOINT

ROLLED EXTRUDED RAIL

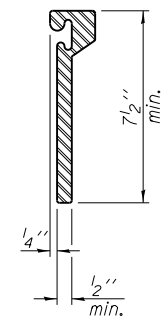

WELDED RAIL

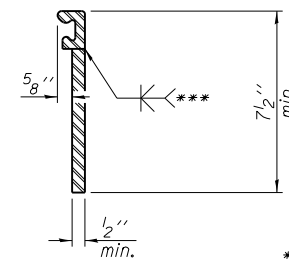

LOCKING EDGE RAIL SPLICE

The inside of the locking edge rail groove shall be free of weld residue. Rolled rail shown, welded rail similar.

*** Back gauge not required if complete joint penetration is verified by mock-up.

LOCKING EDGE RAILS

BILL OF MATERIAL

Item	Unit	Total
Preformed Joint Strip Seal	Foot	182

EJ-SSJ 7-1-10
BENTON & ASSOCIATES, INC.

* Granular or solid flux filled headed studs conforming to Article 1006.32 of the Std. Specs., automatically end welded.

FILE NAME = P:\10e2166-2\Design\Plans\082-0166\0820166-76022-007-Joint.dgn

USER NAME =
PLOT SCALE =
PLOT DATE =

DESIGNED - MBH
CHECKED - SJH
DRAWN - MBH
CHECKED - SJH
REVISED -
REVISED -
REVISED -
REVISED -

STATE OF ILLINOIS
DEPARTMENT OF TRANSPORTATION

PREFORMED JOINT STRIP SEAL
STRUCTURE NO. 082-0166

SHEET NO. 8 OF 11 SHEETS

F.A.I. RT.E. SECTION COUNTY TOTAL SHEETS SHEET NO.
64 82-1HB1-2 ST. CLAIR 208 194
CONTRACT NO. 76022
FED. ROAD DIST. NO. 8 ILLINOIS FED. AID PROJECT

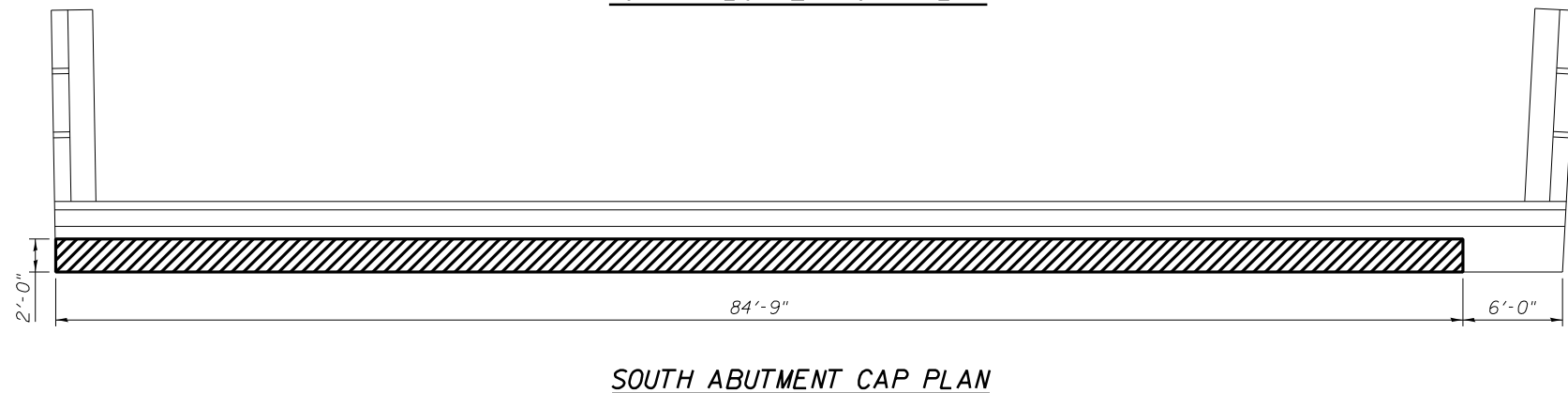
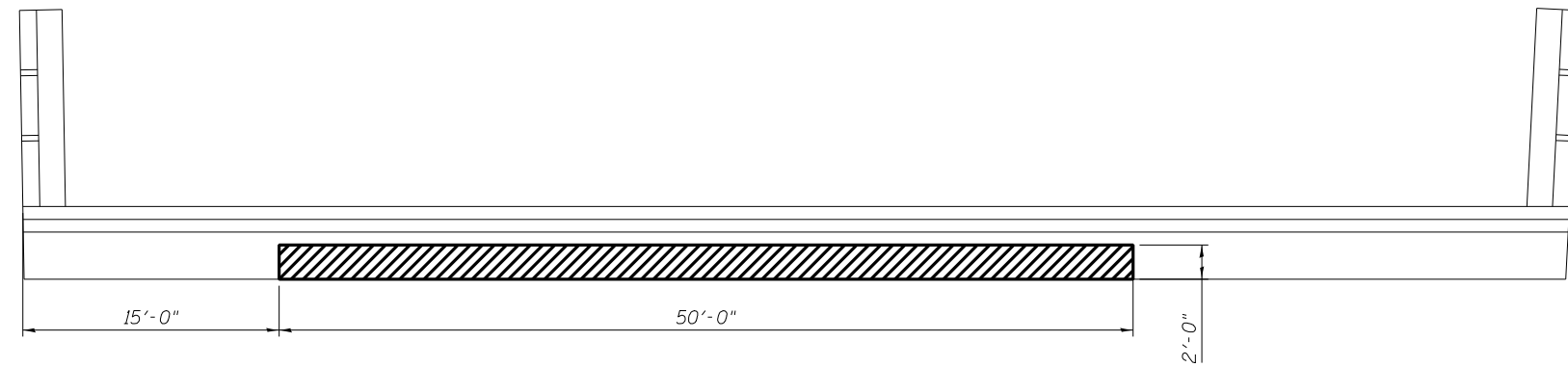
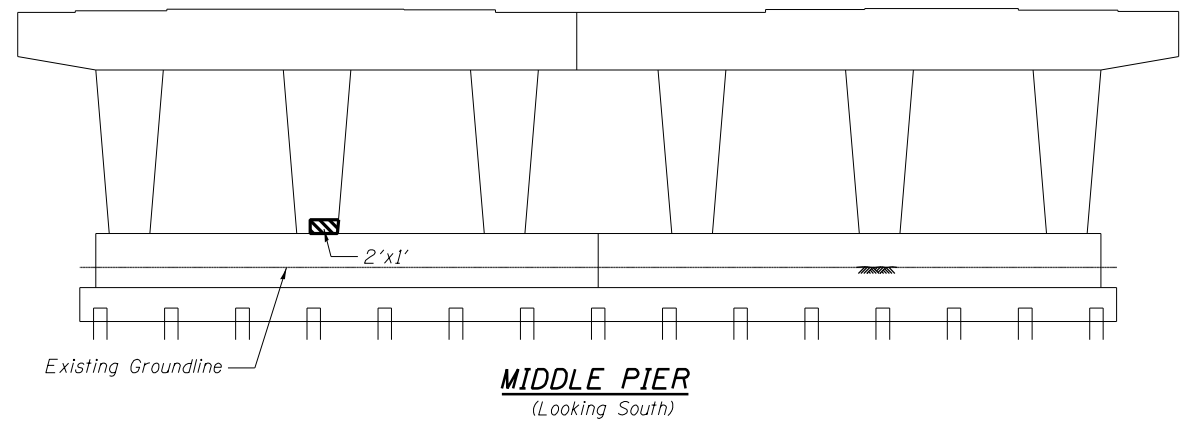
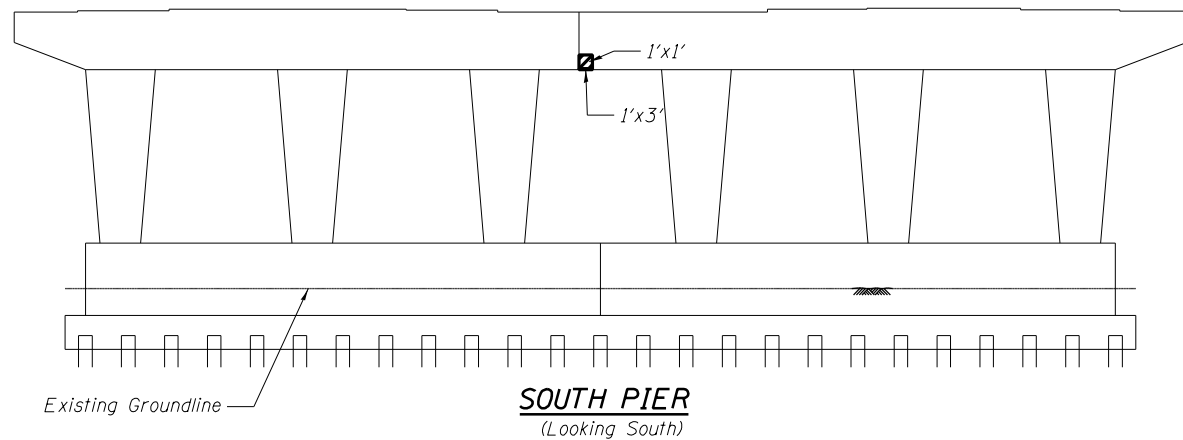
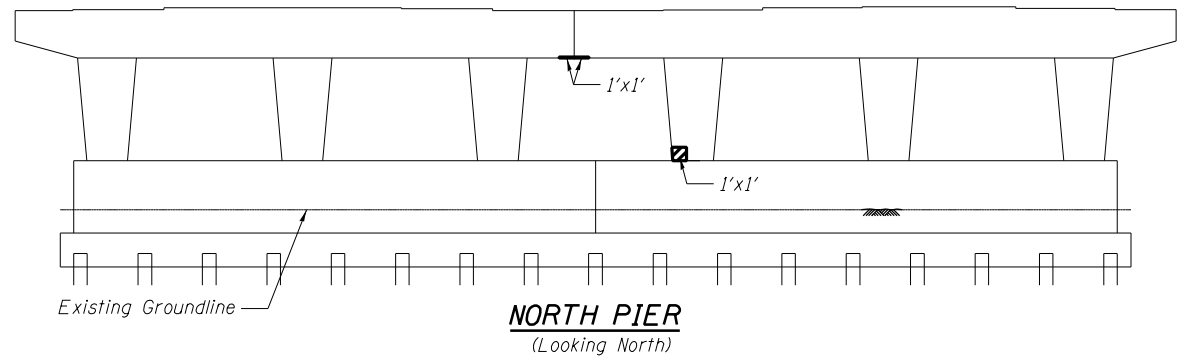
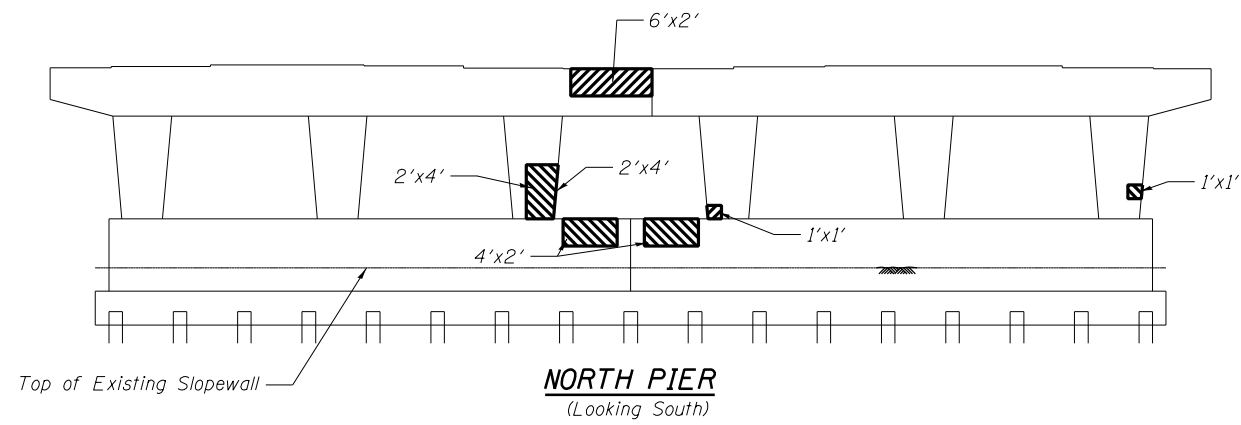

LEGEND

Area of Structural Concrete Repair

BILL OF MATERIAL

Item	Unit	Total
Structural Repair of Concrete (Depth <= 5")	Sq. Ft.	325

BENTON & ASSOCIATES, INC.

FILE NAME = P:\10e2166-2\ Design\ Plans\ 082-0166	USER NAME =	DESIGNED - MBH	REVISED -
0820166-76022-008-Substr.dgn	PLOT SCALE =	CHECKED - SJH	REVISED -
	PLOT DATE =	DRAWN - MBH	REVISED -
		CHECKED - SJH	REVISED -

**STATE OF ILLINOIS
DEPARTMENT OF TRANSPORTATION**

**SUBSTRUCTURE REPAIRS
STRUCTURE NO. 082-0166**

SHEET NO. 9 OF 11 SHEETS

F.A.I. RTE. 64	SECTION 82-3HB-1	COUNTY ST. CLAIR	TOTAL SHEETS 208	SHEET NO. 195
CONTRACT NO. 76022				
FED. ROAD DIST. NO. 8 ILLINOIS FED. AID PROJECT				

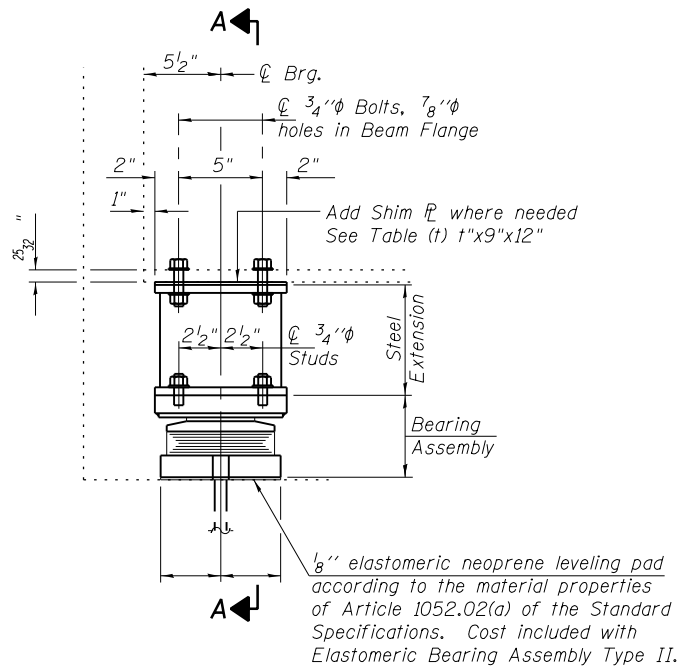

ELEVATION AT ABUTMENT

TYPE II TFE ELASTOMERIC EXP. BRG.

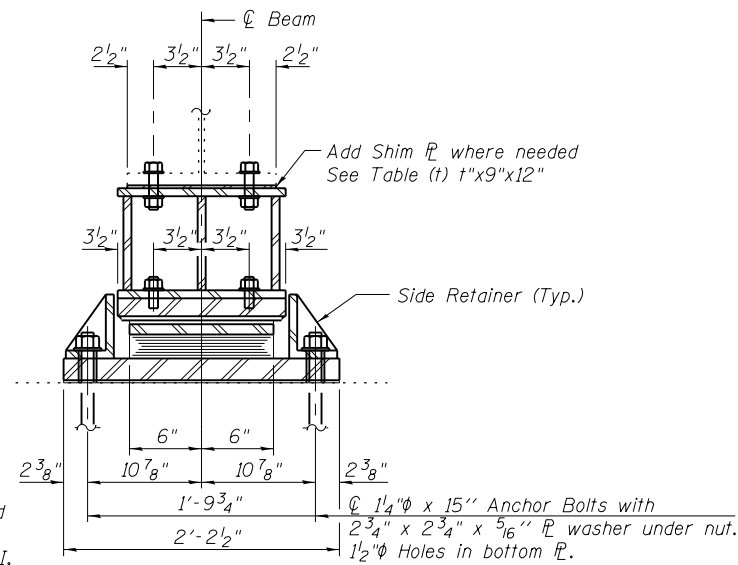

SECTION A-A

Bearing Shim Thickness - t (in.)		1	2	3	4	5	6	7	8	9	10	11	12	13	14
Beam		--	--	--	1/16"	2"	--	1/8"	--	--	--	1/8"	--	--	--
S. Abut.		--	--	--	1/16"	2"	--	1/8"	--	--	--	1/8"	--	--	--

BEAM REACTIONS

R _P	(K)	21
R _L	(K)	44
Imp.	(K)	12
R (Total)	(K)	77

Notes:

Diaphragm removal and reinstallation may be required to facilitate drilling holes. Cost included with Furnishing and Erecting Structural Steel.

New steel extensions, shim plates and connection bolts are included with Furnishing and Erecting Structural Steel.

Prior to ordering any material, the Contractor shall verify in the field all bearing height and shim thickness dimensions. Min. jack capacity = 40 Tons.

Anchor bolts shall be ASTM F1554 all-thread (or an Engineer-approved alternate material) of the grade(s) and diameter(s) specified. ASTM A307 Grade C anchor bolts may be used in lieu of ASTM F1554 Grade 36 (Fy=36ksi). The corresponding specified grade of AASHTO M314 anchor bolts may be used in lieu of ASTM F1554.

Anchor bolts at fixed bearings may be either cast in place or installed in holes drilled after the supported member is in place.

Anchor bolts for Type II bearings shall be placed in holes drilled through the bottom bearing plate after members are in place. Side retainers shall be placed after bolts are installed.

Drilled and set anchor bolts shall be installed according to Article 521.06 of the Standard Specifications.

Side retainers shall be included in the cost of Elastomeric Bearing Assembly, Type II.

The 1/8" PTFE sheet shall be bonded directly to the top steel plate with a two-component, medium viscosity epoxy resin, conforming to the requirements of the Federal Specification MMM-A-134, Type I. The bond agent shall be applied on the full area of the contact surfaces.

Bonding of 1/8" PTFE sheet during vulcanizing process will be permitted provided the process and method of adjusting assembly height is approved by the Engineer.

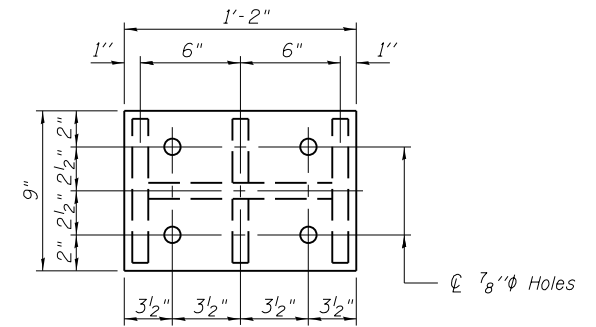

PLAN TOP AND BOTTOM PLATE

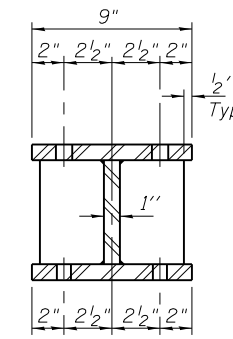

SECTION B-B

STEEL EXTENSION DETAIL

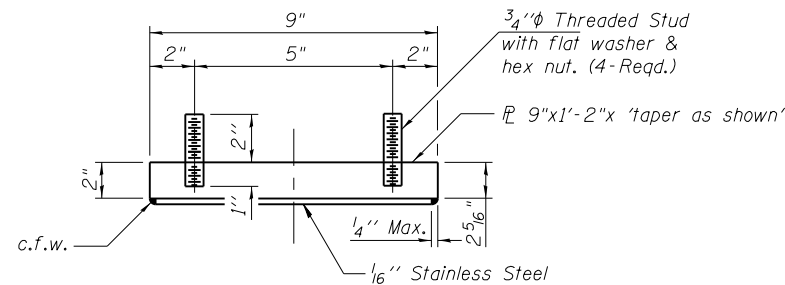

TOP BEARING ASSEMBLY

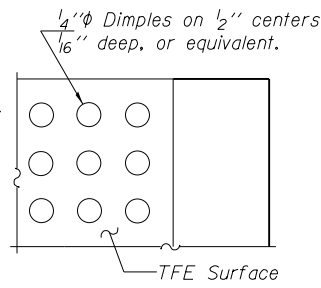

PLAN-PTFE SURFACE

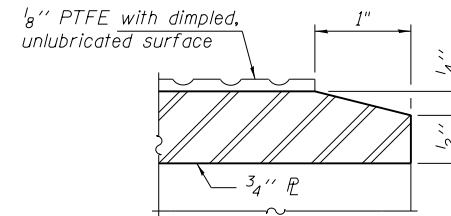

SECTION THRU PTFE

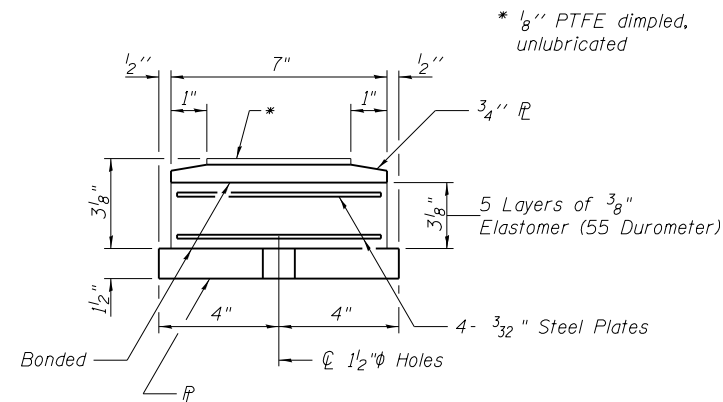

BOTTOM BEARING ASSEMBLY

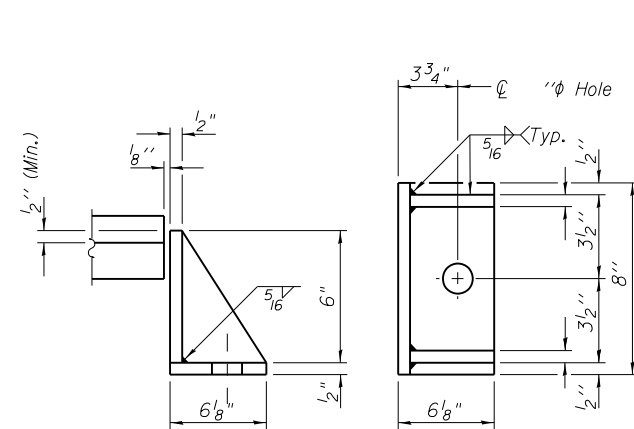

SIDE RETAINER

Equivalent rolled angle with stiffeners will be allowed in lieu of welded plates.

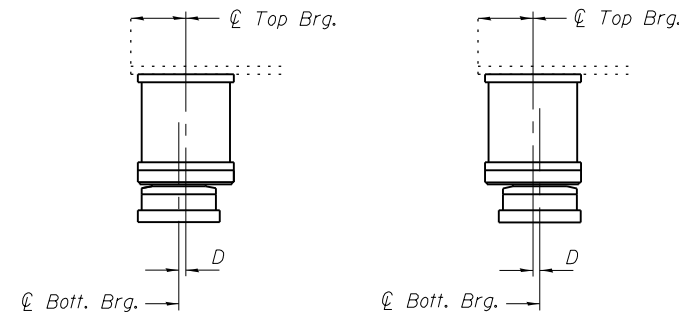

SETTING ANCHOR BOLTS AT EXP. BRG.
 D = 1/8" per each 100' of expansion for every 15° temp. change from the normal temp. of 50°F.

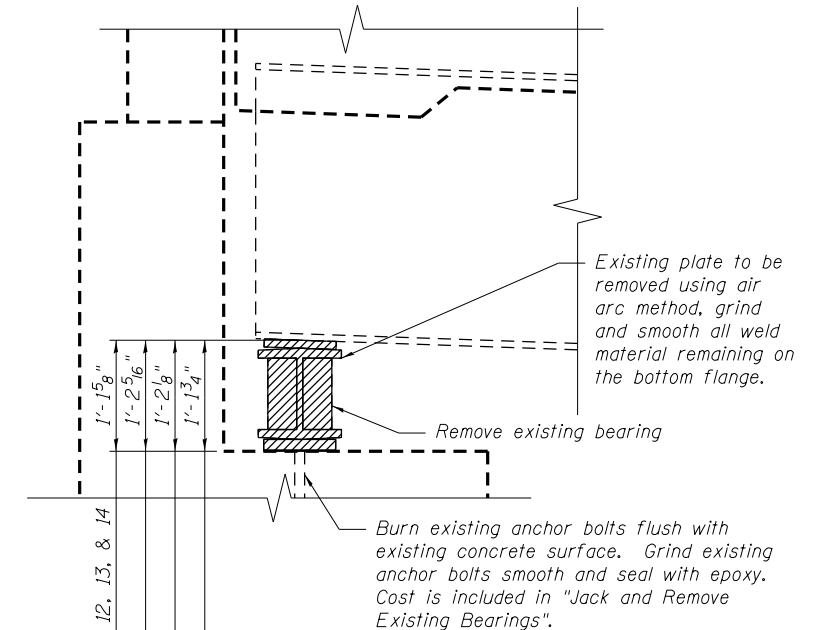

BILL OF MATERIAL

Item	Unit	Total
Elastomeric Bearing Assembly, Type II	Each	14
Jack and Remove Existing Bearings	Each	14
Furnishing and Erecting Structural Steel	Pound	1740
Anchor Bolts 1 1/4"	Each	28

TYII/REPS 12-03-2008
BENTON & ASSOCIATES, INC.

FILE NAME = P:\1002166-2\Design\Plans\082-0166	USER NAME =	DESIGNED - MBH	REVISED - 10/3/13
0820166-76022-009-Bearing.dgn	PLOT SCALE =	CHECKED - SJH	REVISED -
	PLOT DATE =	DRAWN - MBH	REVISED -
		CHECKED - SJH	REVISED -

**STATE OF ILLINOIS
 DEPARTMENT OF TRANSPORTATION**

**SOUTH ABUTMENT BEARING DETAILS
 STRUCTURE NO. 082-0166**

SHEET NO. 10 OF 11 SHEETS

F.A.I. RTE. 64	SECTION 82-3HB-1	COUNTY ST. CLAIR	TOTAL SHEETS 208	SHEET NO. 196
CONTRACT NO. 76022				
FED. ROAD DIST. NO. 8 ILLINOIS FED. AID PROJECT				

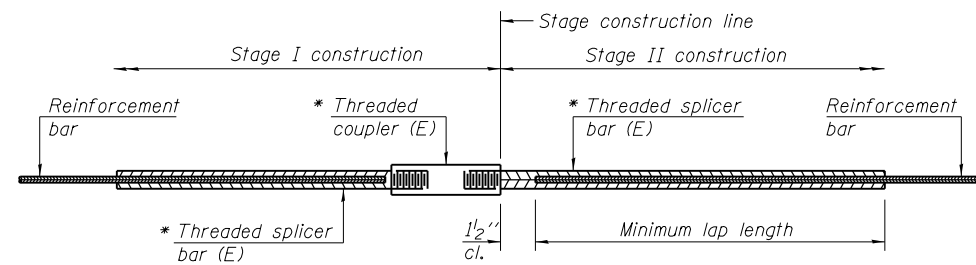

STANDARD BAR SPLICER ASSEMBLY

Minimum Lap Lengths					
Bar size to be spliced	Table 1	Table 2	Table 3	Table 4	Table 5
3, 4	1'-5"	1'-11"	2'-1"	2'-4"	2'-3"
5	1'-9"	2'-5"	2'-7"	2'-11"	2'-10"
6	2'-1"	2'-11"	3'-1"	3'-6"	3'-4"
7	2'-9"	3'-10"	4'-2"	4'-8"	4'-6"
8	3'-8"	5'-1"	5'-5"	6'-2"	5'-10"
9	4'-7"	6'-5"	6'-10"	7'-9"	7'-5"

- Table 1: Black bar, 0.8 Class C
- Table 2: Black bar, Top bar lap, 0.8 Class C
- Table 3: Epoxy bar, 0.8 Class C
- Table 4: Epoxy bar, Top bar lap, 0.8 Class C
- Table 5: Epoxy bar, Top bar lap, Class B

Threaded splicer bar length = min. lap length + 1/2" + thread length

* Epoxy not required on Bar Splicer Assembly components used in conjunction with black bars.

Location	Bar size	No. assemblies required	Table for minimum lap length
SN 082-0166 Deck	#6	8	Table 3
SN 082-0166 Deck	#6	8	Table 3
SN 082-0166 Deck	#6	8	Table 3
SN 082-0166 Deck	#6	8	Table 3
SN 082-0166 Hatch	#6	4	Table 3
SN 082-0166 Hatch	#6	4	Table 3
SN 082-0166 Hatch	#6	4	Table 3
SN 082-0166 Hatch	#6	4	Table 3

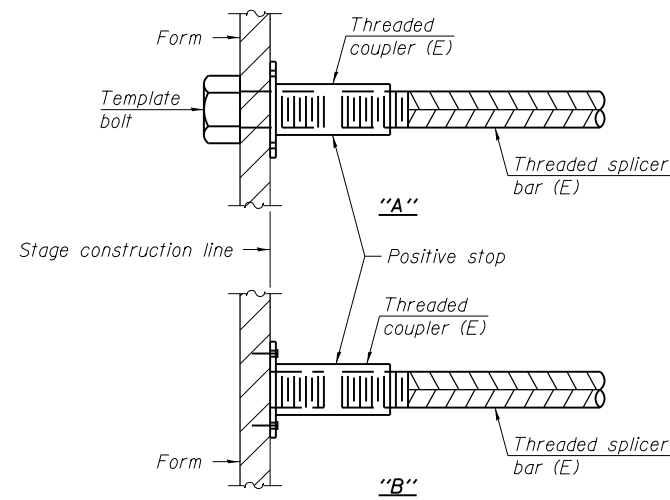

INSTALLATION AND SETTING METHODS

"A" : Set bar splicer assembly by means of a template bolt.
 "B" : Set bar splicer assembly by nailing to wood forms or cementing to steel forms.
 (E) : Indicates epoxy coating.

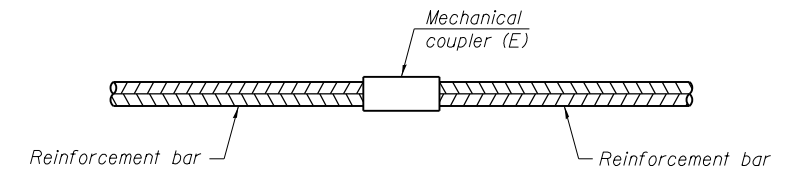

STANDARD MECHANICAL SPLICER

Location	Bar size	No. assemblies required

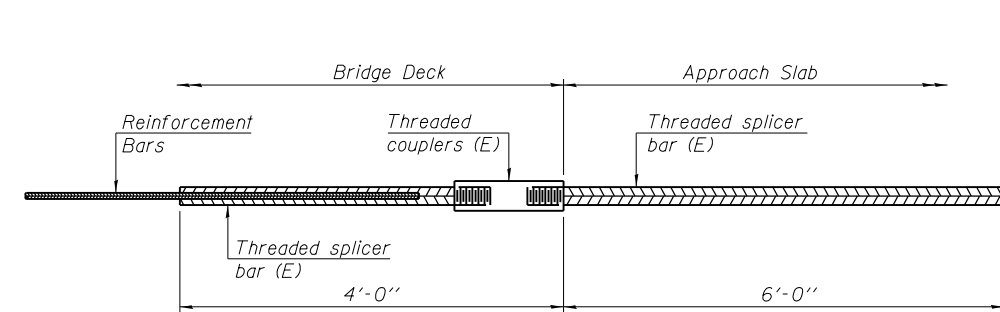

BAR SPLICER ASSEMBLY FOR #5 BAR ON INTEGRAL OR SEMI-INTEGRAL ABUTMENTS

No. required =

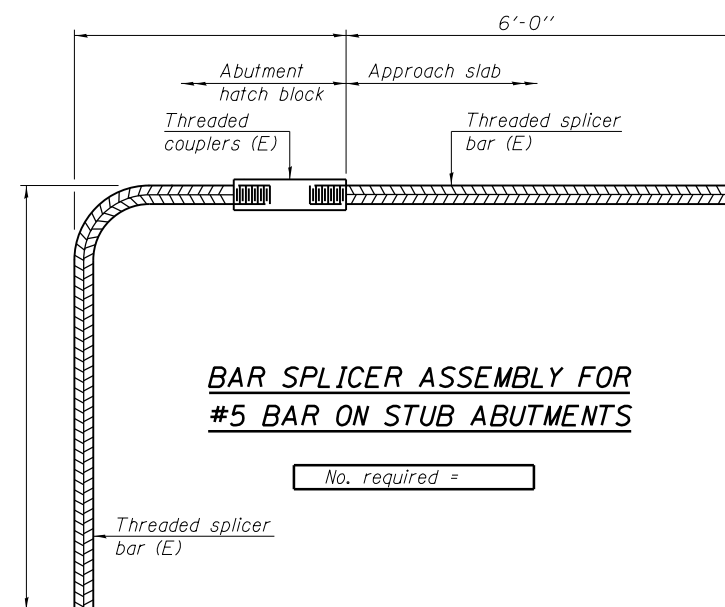

BAR SPLICER ASSEMBLY FOR #5 BAR ON STUB ABUTMENTS

No. required =

NOTES

- Splicer bars shall be deformed with threaded ends and have a minimum 60 ksi yield strength.
- All reinforcement shall be lapped and tied to the splicer bars.
- Bar splicer assemblies shall be epoxy coated according to the requirements for reinforcement bars. See Section 508 of the Standard Specifications.
- See special provision for Mechanical Splicers.
- See approved list of bar splicer assemblies and mechanical splicers for alternatives.

BSD-1 7-1-10
 BENTON & ASSOCIATES, INC.

FILE NAME = P:\10e2166-2\Design\Plans\082-0166\0820166-76022-010-Splicer.dgn	USER NAME =	DESIGNED - MBH	REVISED - 10/3/13
		CHECKED - SJH	REVISED -
	PLOT SCALE =	DRAWN - MBH	REVISED -
	PLOT DATE =	CHECKED - SJH	REVISED -

STATE OF ILLINOIS
 DEPARTMENT OF TRANSPORTATION

BAR SPLICER ASSEMBLY AND MECHANICAL SPLICER DETAILS
 STRUCTURE NO. 082-0166

SHEET NO. 11 OF 11 SHEETS

F.A.I. RTE.	SECTION	COUNTY	TOTAL SHEETS	SHEET NO.
64	82-3HB-1	ST. CLAIR	208	197
CONTRACT NO. 76022				
FED. ROAD DIST. NO. 8 ILLINOIS FED. AID PROJECT				

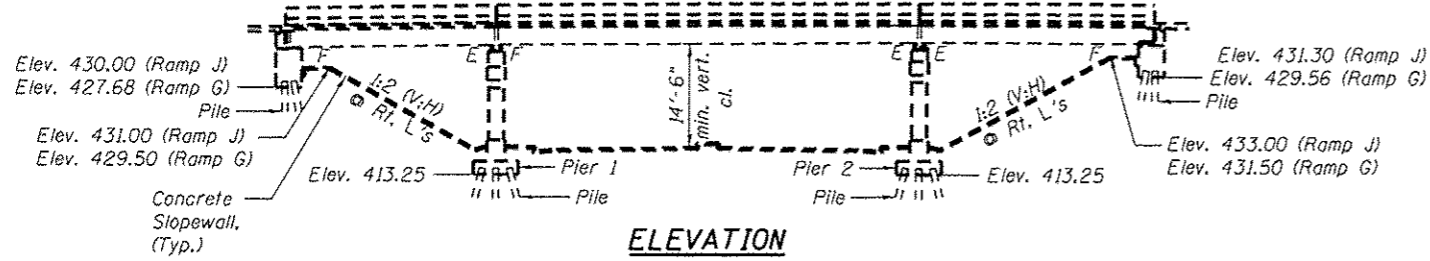

CURVE DATA RAMP G		CURVE DATA RAMP J	
CURVE 3	CURVE 4	CURVE 3	CURVE 4
PI STA. = 6+71.78	PI STA. = 11+85.17	PI STA. = 7+70.12	PI STA. = 11+56.90
Δ = 51° 40' 22"	Δ = 100° 01' 50"	Δ = 9° 42' 25"	Δ = 59° 44' 16"
D = 24° 54' 54"	D = 16° 22' 13"	D = 14° 46' 01"	D = 18° 35' 25"
R = 229.96'	R = 350'	R = 388'	R = 308.20'
L = 207.40'	L = 611.05'	L = 65.74'	L = 321.34'
T = 111.35'	T = 417.34'	T = 32.95'	T = 177.00'
PCC STA = 5+60.43	PCC STA = 7+67.83	PCC STA = 7+37.17	PC STA = 9+79.89
PCC STA = 7+67.83	PT STA = 13+78.88	PT STA = 8+02.91	
0.08% Superlevation	0.08% Superlevation		

ORIGINAL DESIGN STRESSES

FIELD UNITS

f'_c = 1,400 psi (Piers and Superstructure)
 f'_c = 1,000 psi (Substructure w/ Earth Pressure)
 f_y = 20,000 psi (Reinforcement)
 f_y = 20,000 psi (Structural Steel A36)
 n = 10
 N = 75 psi

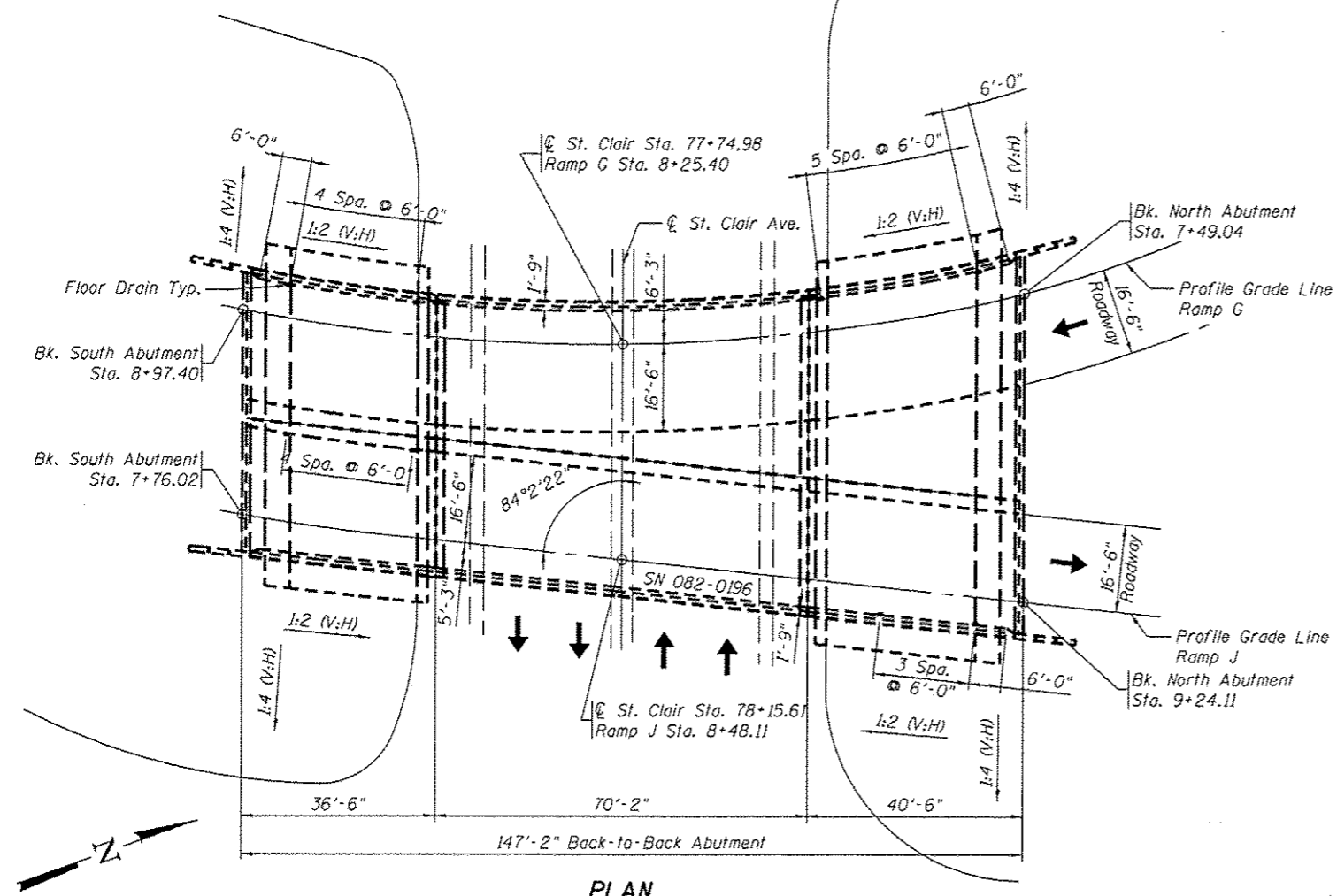

INDEX OF SHEETS

General Plan & Elevation	1
Deck Repairs	2
Concrete Removal & Replacement	3-4
Prefomed Joint Strip Seal	5
Slab Cross Sections	6
Bearing Details	7-9
Substructure Repairs	10
Abutment Repairs	11

GENERAL NOTES

- All new structural steel shall conform to AASHTO Classification M270 Gr. 36 unless otherwise noted.
- Fasteners shall be AASHTO MI64 Type 1, mechanically galvanized bolts (in painted areas and MI64 Type 3 in unpainted areas). Bolts 1/8"φ, holes 1/8"φ, unless otherwise noted.
- No field welding is permitted except as specified in the contract documents.
- Reinforcement bars designated (E) shall be epoxy coated.
- Prior to pouring the new concrete deck, all heavy or loose rust, loose mill scale, and other loose or potentially detrimental foreign material shall be removed from the surfaces in contact with concrete. Tightly adhered paint may remain unless otherwise noted. Removal shall be accomplished by methods that will not damage the steel and the cost will be included in the pay item covering removal of the existing concrete.
- As directed by the Engineer, existing construction accessories welded to the top flange of beams and girders shall be removed. The weld areas shall be ground flush and inspected for cracks using magnetic particle testing (MT) or dye penetrant testing (PT) by qualified personnel approved by the Engineer. Any cracks that can not be removed by grinding 1/4 in. deep shall be identified and reported to the Bureau of Bridges and Structures for further disposition. The cost of removing welded accessories, grinding and inspecting weld areas and grinding cracks will be paid for according to Article 109.04 of the Standard Specifications.
- Plan dimensions and details relative to existing plans are subject to nominal construction variations. The Contractor shall field verify existing dimensions and details affecting new construction and make necessary approved adjustments prior to construction or ordering of materials. Such variations shall not be cause for additional compensation for a change in scope of the work, however, the Contractor will be paid for the quantity actually furnished at the unit price bid for the work.
- Existing reinforcement bars extending into the removal area shall be cleaned, straightened and incorporated into the new construction. Any reinforcement bars that are damaged during concrete removal shall be replaced with an approved bar splicer or anchorage system. Cost included with Concrete Removal.
- Joint openings shall be adjusted according to Article 520.04 of the Standard Specs. when the deck is poured at an ambient temperature other than 50° F.
- Areas of deck repairs shown are estimated. The Engineer shall show actual locations of deck repairs on As-built Plans.
- All structural steel shall be shop painted with the inorganic zinc rich primer per AASHTO M300, Type 1. Color to match existing. Cost included with Furnishing and Erecting Structural Steel.
- The existing structural steel contains lead. The contractor shall take appropriate precautions to deal with the presence of lead on this project.
- Existing structural steel that will be in contact with new structural steel shall be cleaned and painted prior to erection as required by the Special Provisions "Cleaning & Painting Contact Surface Areas of Existing Steel Structures".
- Work to be completed under Road Closure.

TOTAL BILL OF MATERIAL

ITEM	UNIT	QUANTITY
Silicone Joint Sealer, 1/2"	Foot	147
Concrete Removal	Cu. Yd.	16.5
Concrete Superstructure	Cu. Yd.	16.3
Bridge Deck Concrete Sealer	Sq. Ft.	2620
Jack and Remove Existing Bearings	Each	28
Reinforcement Bars, Epoxy Coated	Pound	2810
Prefomed Joint Strip Seal	Foot	116
Elastomeric Bearing Assembly, Type I	Each	28
Anchor Bolts, 1"	Each	56
Structural Repair of Concrete (Depth <= 5")	Sq. Ft.	338
Waterproofing Membrane System	Sq. Yd.	725
Deck Slab Repair (Full)	Sq. Yd.	2.2
Bituminous Materials (Prime Coat)	Tons	0.3
Hot-Mix Asphalt Surface Course, Mix D, N50	Tons	61.0
Hot-Mix Asphalt Surface Removal, 1 1/2"	Sq. Yd.	725
Protective Shield	Sq. Yd.	32
Furnishing and Erecting Structural Steel	Pound	4400

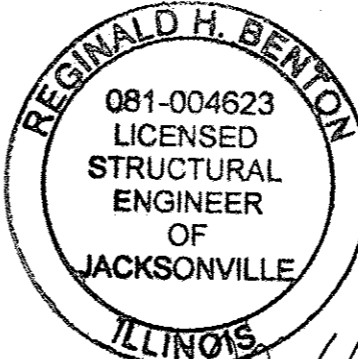
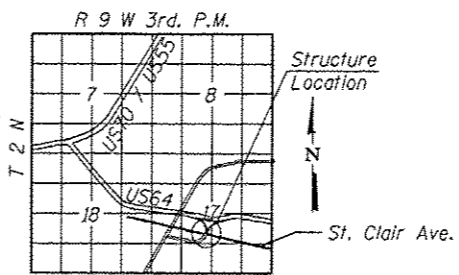

Reginald H. Benton
 08/20/13 EXP 11/30/14

GENERAL PLAN & ELEVATION
INTERSTATE 64 (RAMP G & J) OVER ST. CLAIR AVE.
F.A.I. RTE. 64 - SEC. 82-2HB-1
ST. CLAIR COUNTY
RAMP J STA. 8+48.11
ST. CLAIR AVE. STA. 78+15.61

BENTON & ASSOCIATES, INC.

FILE NAME = P:\102166-5\ Design\	USER NAME =	DESIGNED - MBH	REVISED -	STATE OF ILLINOIS DEPARTMENT OF TRANSPORTATION	GENERAL PLAN & ELEVATION STRUCTURE NO. 082-0196	F.A.I. RTE.	SECTION	COUNTY	TOTAL SHEETS	SHEET NO.	
Plans\ 0820196-76022-		CHECKED - SJH	REVISED -			64	82-2HB-1	ST. CLAIR	208	198	
081-GPE.dgn	PLOT SCALE =	DRAWN - MBH	REVISED -			CONTRACT NO. 76022					
	PLOT DATE =	CHECKED - SJH	REVISED -			FED. ROAD DIST. NO. 8 [ILLINOIS] FED. AID PROJECT					

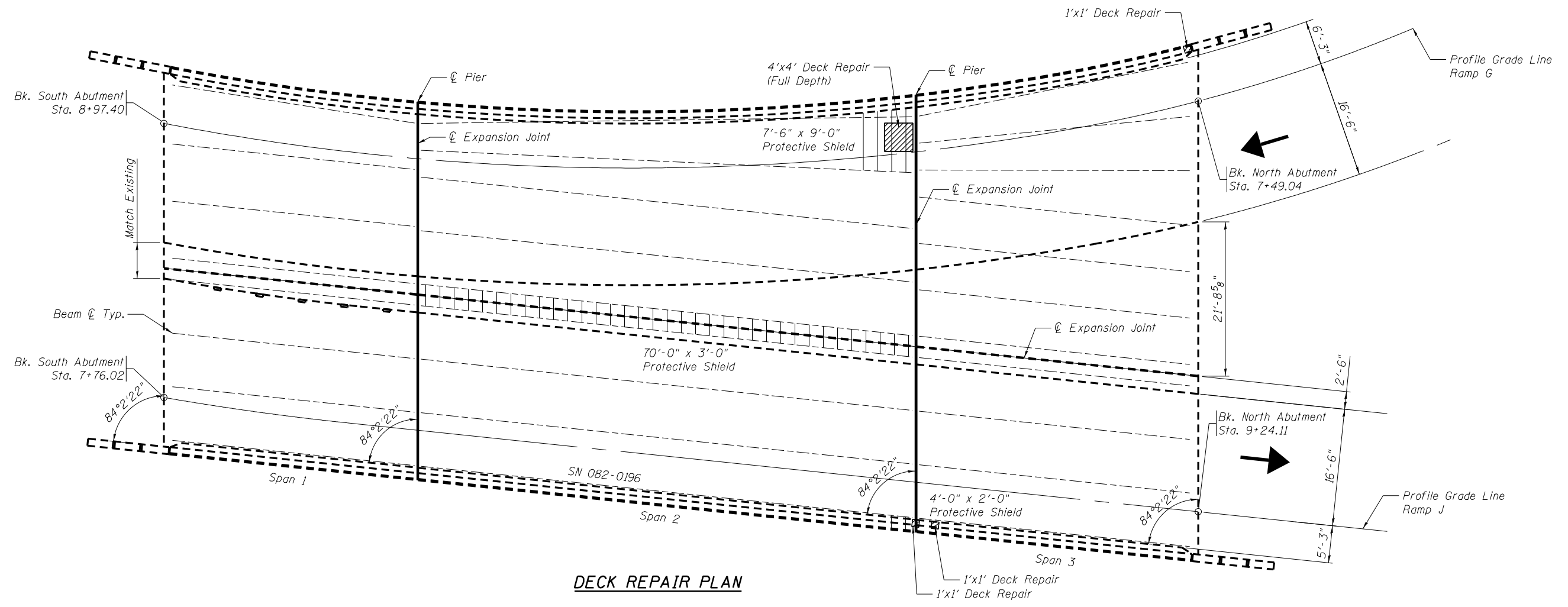
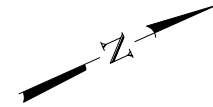

DECK REPAIR PLAN

BILL OF MATERIAL

Waterproofing Membrane System	Sq. Yd.	725
Deck Slab Repair (Full)	Sq. Yd.	2.2
Protective Shield	Sq. Yd.	32

BENTON & ASSOCIATES, INC.

FILE NAME = P:\10e2166-5\ Design\ Plans\ 0820196-76022-002-Deck.dgn	USER NAME =	DESIGNED - MBH	REVISED -
		CHECKED - SJH	REVISED -
	PLOT SCALE =	DRAWN - MBH	REVISED -
	PLOT DATE =	CHECKED - SJH	REVISED -

**STATE OF ILLINOIS
DEPARTMENT OF TRANSPORTATION**

**DECK REPAIRS
STRUCTURE NO. 082-0196**

SHEET NO. 2 OF 11 SHEETS

F.A.I. RTE.	SECTION	COUNTY	TOTAL SHEETS	SHEET NO.
64	82-2HB-1	ST. CLAIR	208	199
CONTRACT NO. 76022				
FED. ROAD DIST. NO. 8 ILLINOIS FED. AID PROJECT				

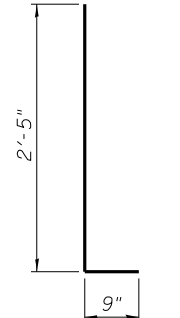
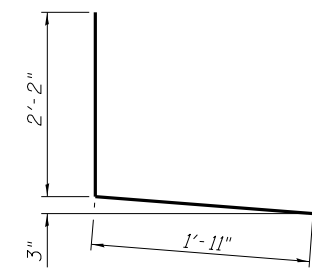
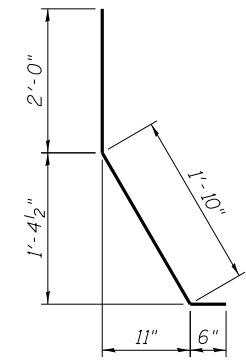
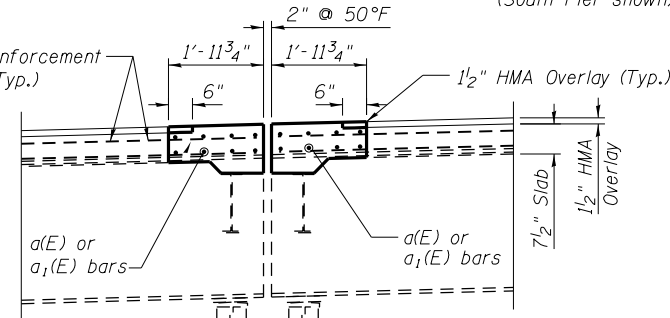
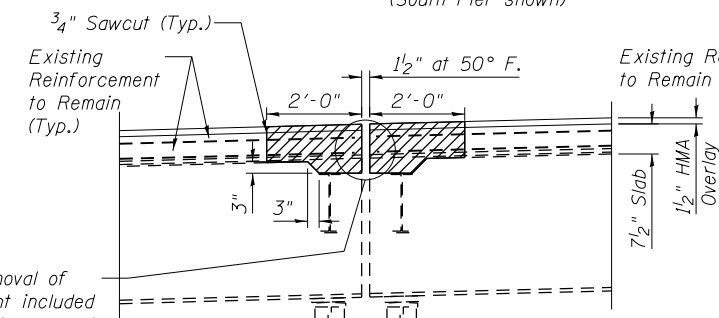
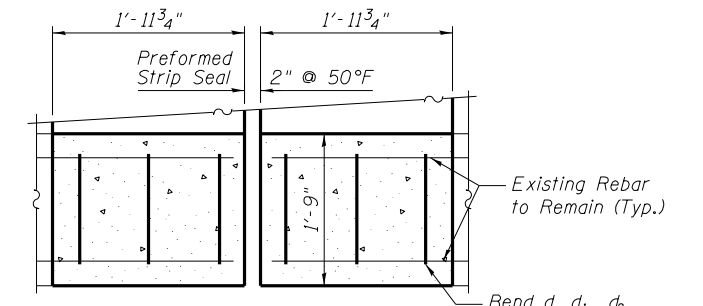
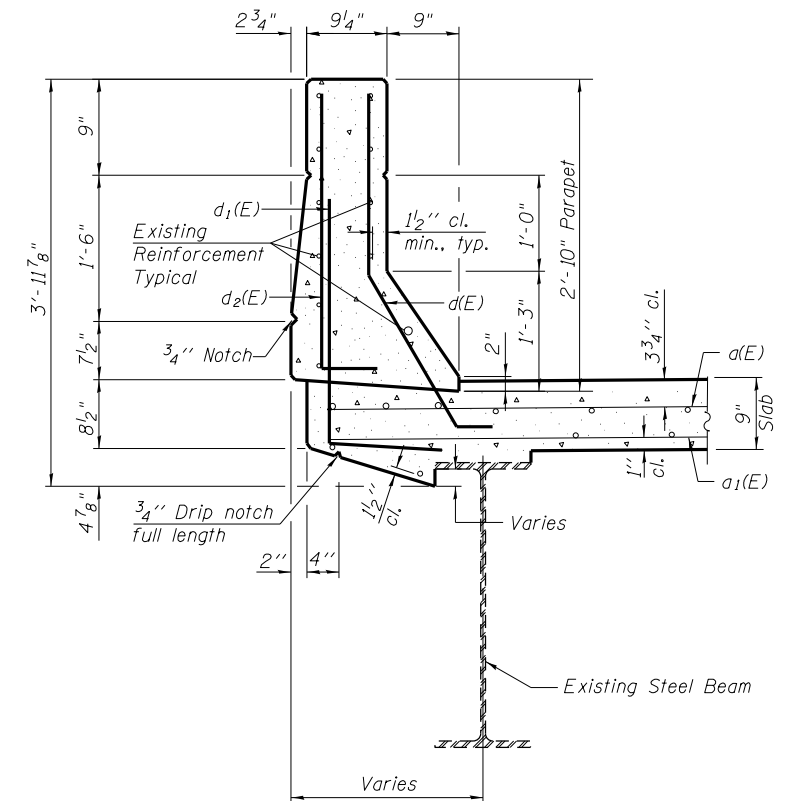
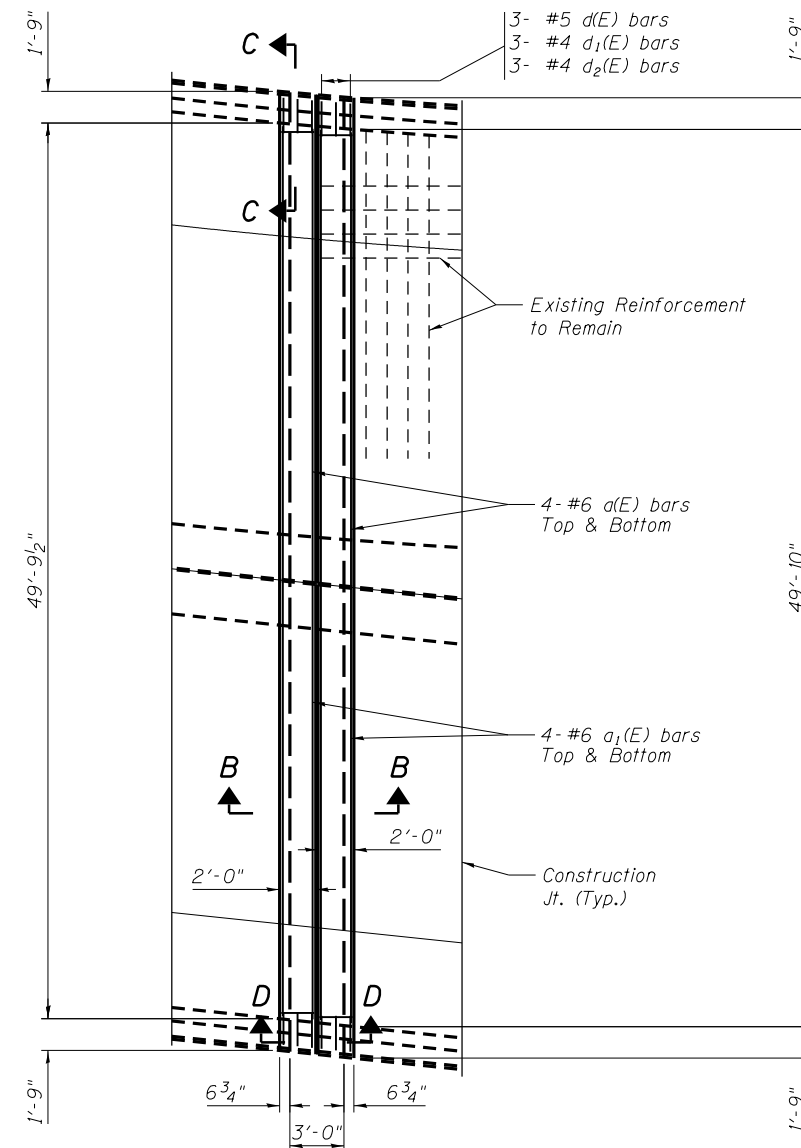
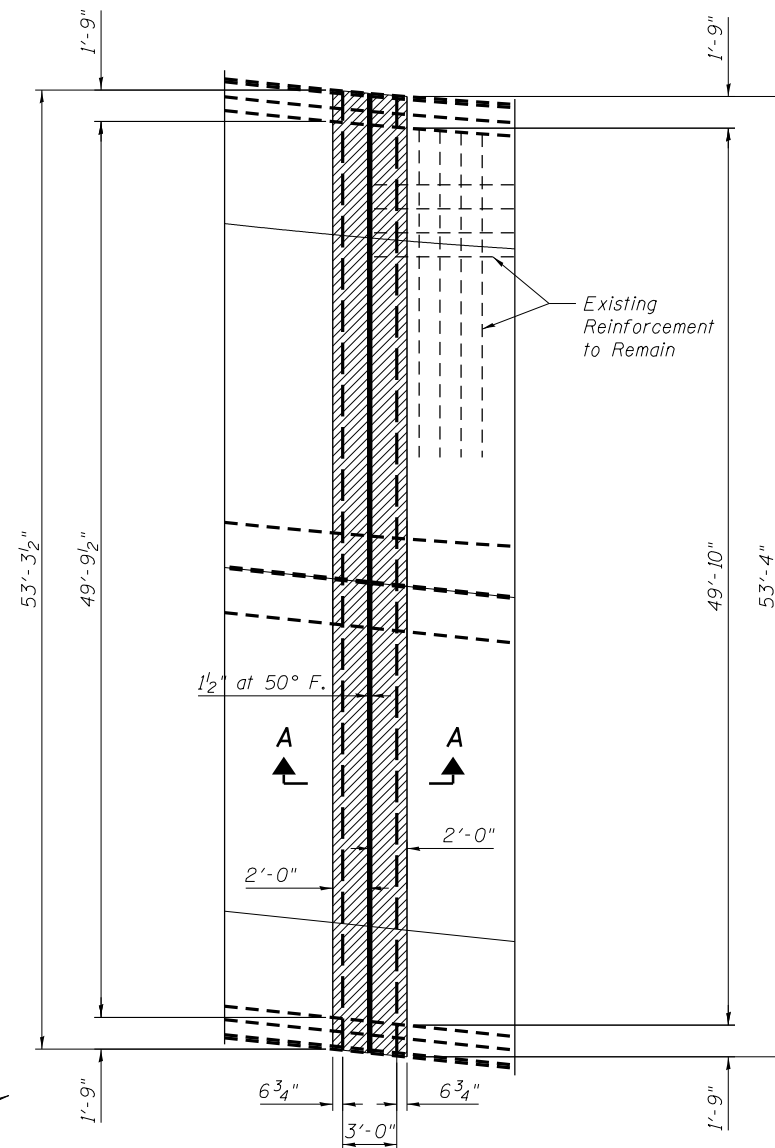

SUPERSTRUCTURE BILL OF MATERIAL

Bar	No.	Size	Length	Shape	
a(E)	16	#6	25'-2"	—	
a1(E)	16	#6	24'-2"	—	
d(E)	12	#5	4'-4"	┌	
d1(E)	12	#4	4'-1"	┌	
d2(E)	12	#4	3'-2"	┌	
Reinforcement Bars, Epoxy Coated				Pound	1300
Concrete Superstructure				Cu. Yds.	7.6
Concrete Removal				Cu. Yds.	7.7
Preformed Strip Seal				Foot	54

Bars indicated thus 4x2 - #6 etc. indicates 4 lines of bars with 2 lengths per line.

BENTON & ASSOCIATES, INC.

FILE NAME = P:\10e2166-5\ Design\ Plans\ 0820196-76022- 003-Deck.dgn	USER NAME =	DESIGNED - MBH	REVISED - 10/3/13
		CHECKED - SJH	REVISED -
	PLOT SCALE =	DRAWN - MBH	REVISED -
	PLOT DATE =	CHECKED - SJH	REVISED -

STATE OF ILLINOIS DEPARTMENT OF TRANSPORTATION

CONCRETE REMOVAL & REPLACEMENT STRUCTURE NO. 082-0196

SHEET NO. 3 OF 11 SHEETS

F.A.I. RTE.	SECTION	COUNTY	TOTAL SHEETS	SHEET NO.
64	82-2HB-1	ST. CLAIR	208	200
CONTRACT NO. 76022				
FED. ROAD DIST. NO. 8 ILLINOIS FED. AID PROJECT				

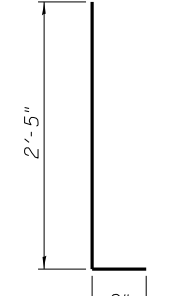
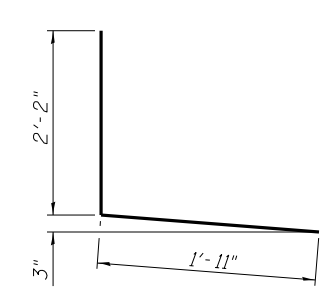
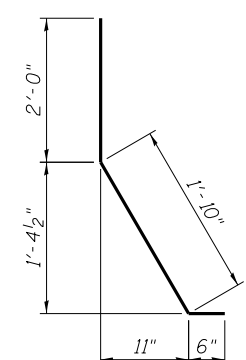
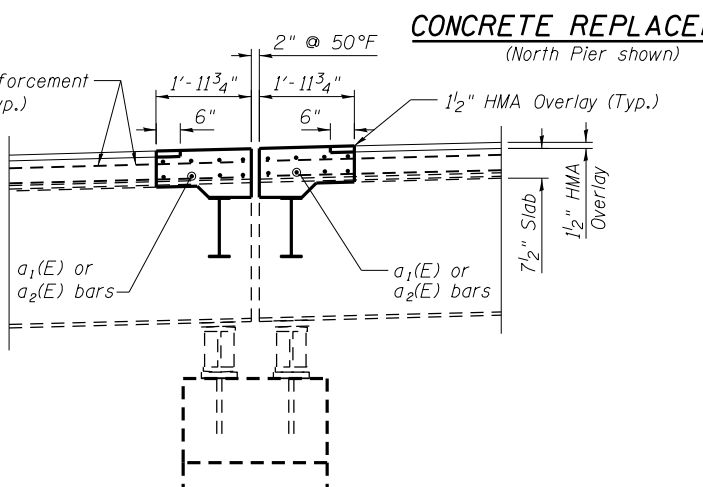
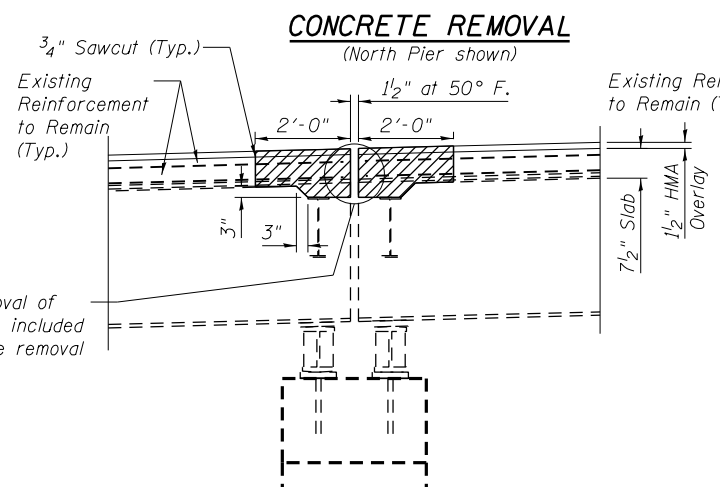
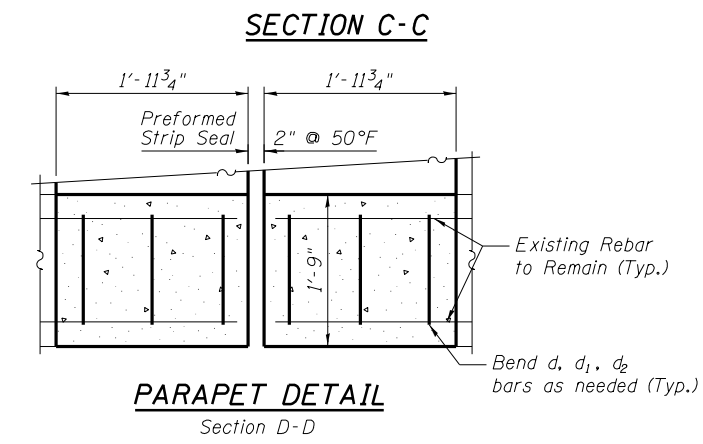
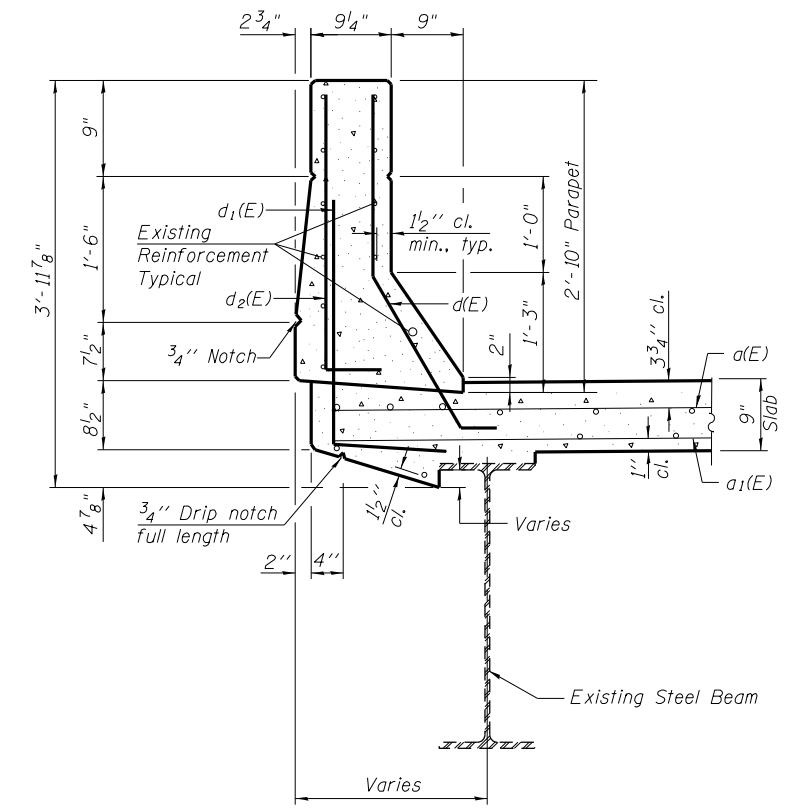
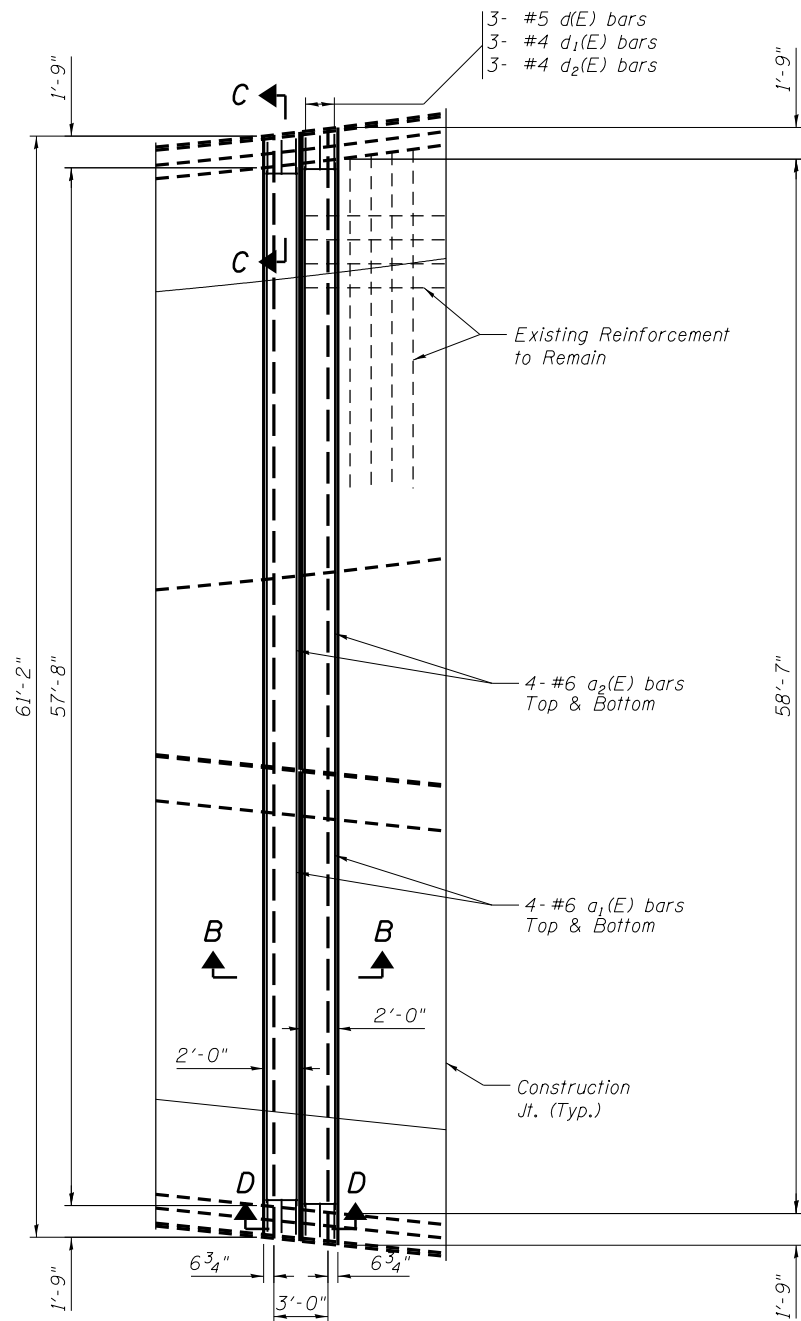
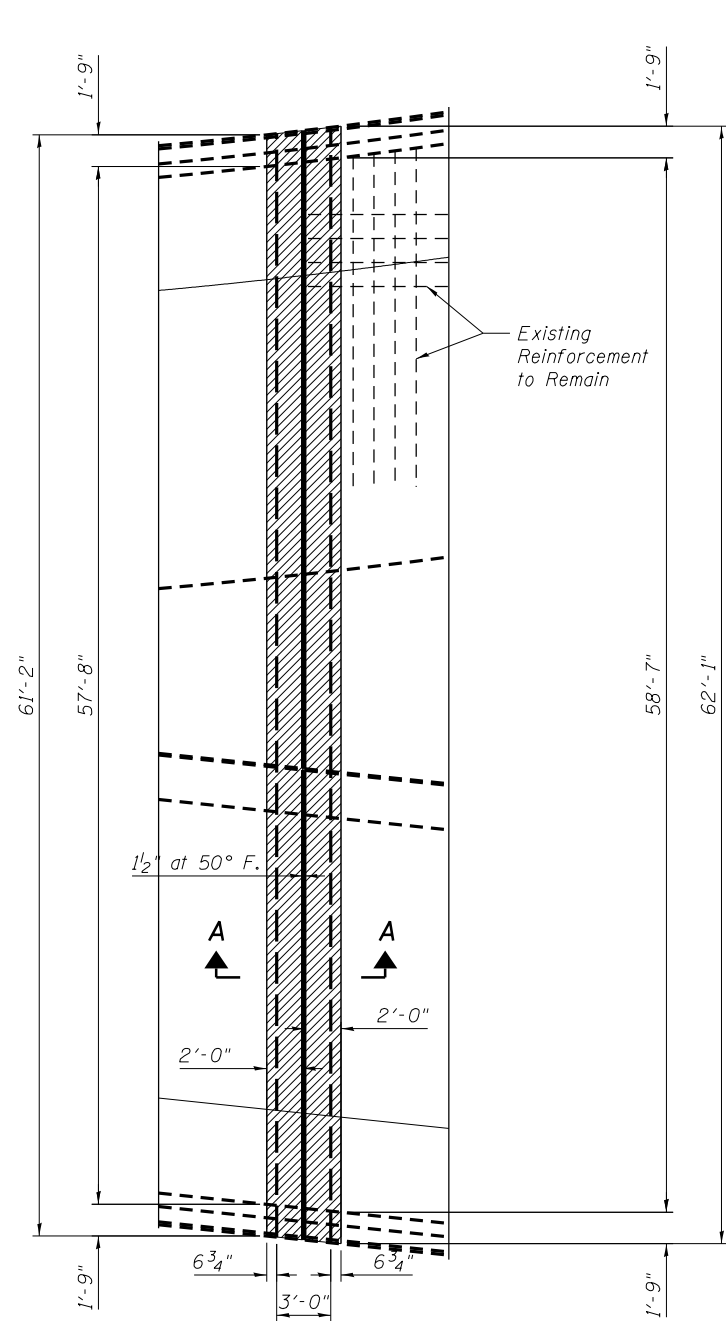

SUPERSTRUCTURE BILL OF MATERIAL

Bar	No.	Size	Length	Shape	
a1(E)	16	#6	24'-2"	—	
a2(E)	16	#6	33'-9"	—	
d(E)	12	#5	4'-4"	┌	
d1(E)	12	#4	4'-1"	┌	
d2(E)	12	#4	3'-2"	┌	
Reinforcement Bars, Epoxy Coated				Pound	1510
Concrete Superstructure				Cu. Yds.	8.7
Concrete Removal				Cu. Yds.	8.8
Preformed Strip Seal				Foot	62

Bars indicated thus 4x2 - #6 etc. indicates 4 lines of bars with 2 lengths per line.

BENTON & ASSOCIATES, INC.

FILE NAME = P:\10e2166-5\ Design\ Plans\ 0820196-76022-004- Deck.dgn	USER NAME =	DESIGNED - MBH	REVISED - 10/3/13
		CHECKED - SJH	REVISED -
	PLOT SCALE =	DRAWN - MBH	REVISED -
	PLOT DATE =	CHECKED - SJH	REVISED -

**STATE OF ILLINOIS
DEPARTMENT OF TRANSPORTATION**

**CONCRETE REMOVAL & REPLACEMENT
STRUCTURE NO. 082-0196**

SHEET NO. 4 OF 11 SHEETS

F.A.I. RTE.	SECTION	COUNTY	TOTAL SHEETS	SHEET NO.
64	82-2HB-1	ST. CLAIR	208	201
CONTRACT NO. 76022				
FED. ROAD DIST. NO. 8 ILLINOIS FED. AID PROJECT				

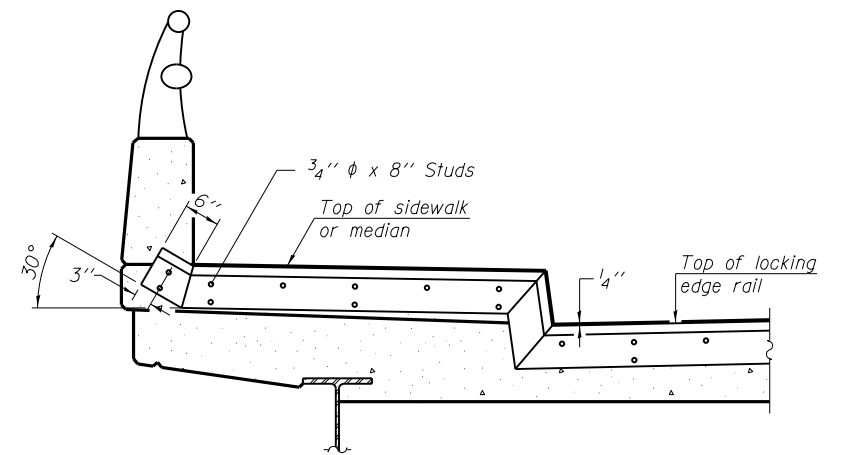
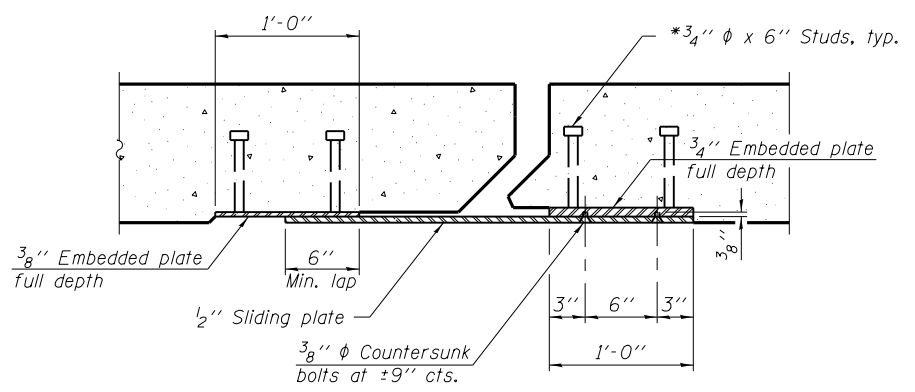
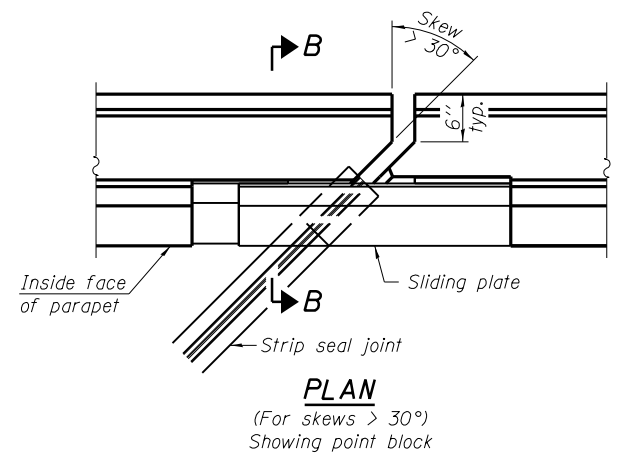
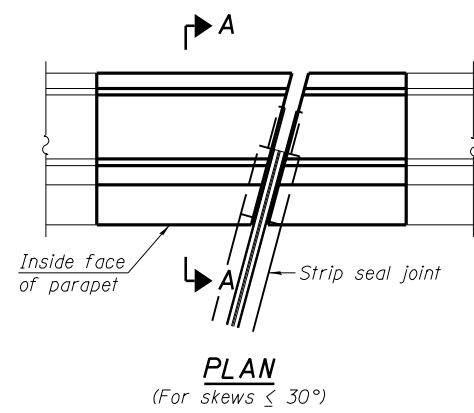

TYPICAL END TREATMENT AT SIDEWALK OR MEDIAN
 Shorter plates with a single row of studs at 12" cts. may be necessary on medians which are shallower than 9". See manufacturer's recommendation.

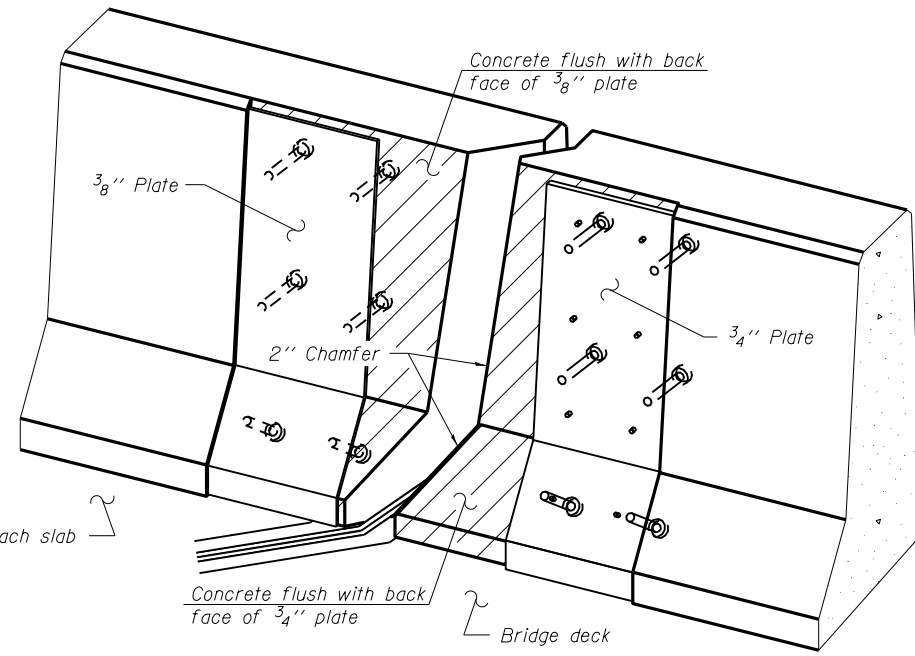
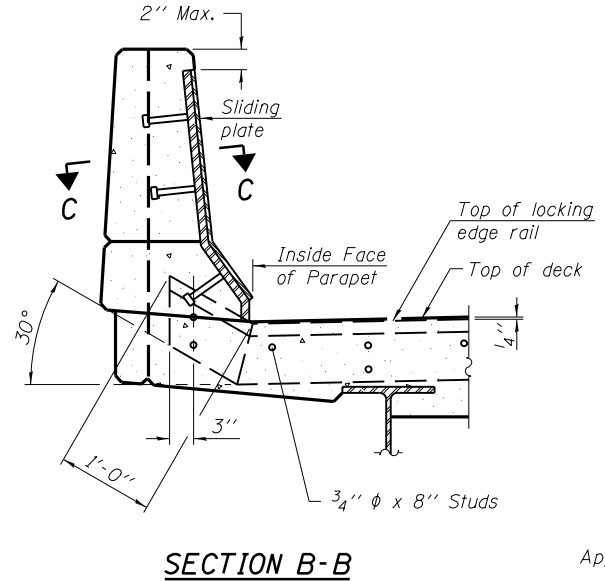
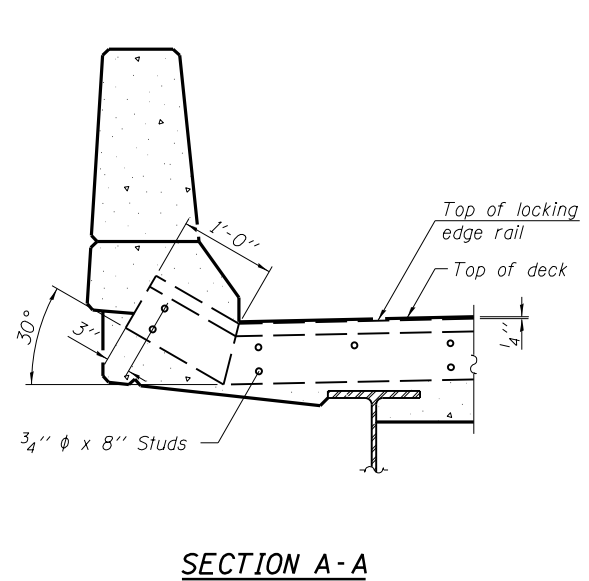

Notes:
 The strip seal shall be made continuous and shall have a minimum thickness of 1/4". The configuration of the strip seal shall match the configuration of the Locking Edge Rails. Open or "webbed" strip seal gland configurations are not permitted. The gland shall be sized for a maximum rated movement of 4 inches.
 The Locking Edge Rails depicted are conceptual only, except for the minimum dimensions shown. The actual configuration of the Locking Edge Rails and matching strip seal may vary from manufacturer to manufacturer. Flanged edge rails will not be allowed. Locking Edge Rails may be spliced at slope discontinuities.
 The manufacturer's recommended installation methods shall be followed.
 The joint opening and deck dimensions detailed on the superstructure are based on a rolled rail expansion joint. If the Contractor elects to use the welded rail expansion joint, the opening and deck dimensions shall be modified according to the dimensions detailed on this sheet. Required modifications shall be made at no additional cost to the State.
 All steel components shall be galvanized after fabrication according to Article 520.03 of the Standard Specifications.
 Maximum space between rail segments at stage lines shall be 3/16", sealed with a suitable sealant.

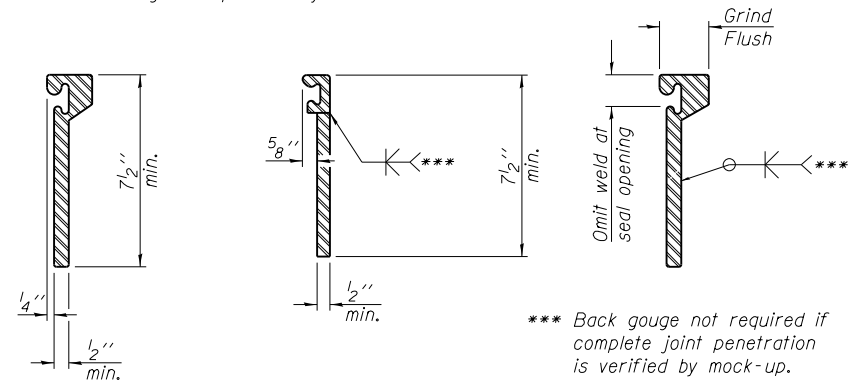
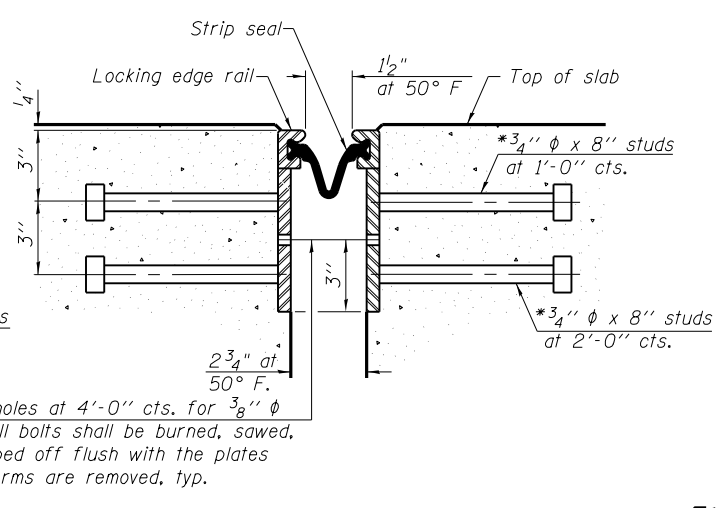
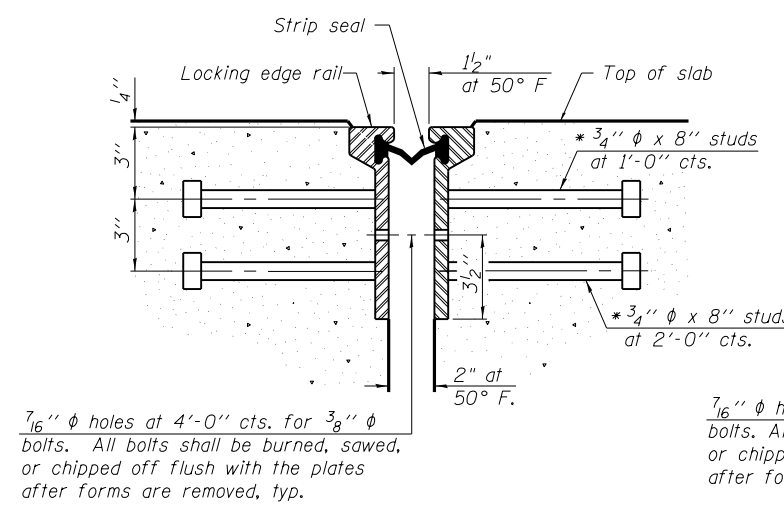

LOCKING EDGE RAIL SPLICE
 The inside of the locking edge rail groove shall be free of weld residue.
 Rolled rail shown, welded rail similar.

BILL OF MATERIAL

Item	Unit	Total
Preformed Joint Strip Seal	Foot	116

EJ-SSJ 7-1-10
BENTON & ASSOCIATES, INC.

* Granular or solid flux filled headed studs conforming to Article 1006.32 of the Std. Specs., automatically end welded.

FILE NAME = P:\10e2166-5\ Design\ Plans\ 0820196-76022-005-Joint.dgn	USER NAME =	DESIGNED - MBH	REVISED -
		CHECKED - SJH	REVISED -
	PLOT SCALE =	DRAWN - MBH	REVISED -
	PLOT DATE =	CHECKED - SJH	REVISED -

STATE OF ILLINOIS
DEPARTMENT OF TRANSPORTATION

PREFORMED JOINT STRIP SEAL
STRUCTURE NO. 082-0196

SHEET NO. 5 OF 11 SHEETS

F.A.I. RE. 64	SECTION 82-1HB1-2	COUNTY ST. CLAIR	TOTAL SHEETS 208	SHEET NO. 202
FED. ROAD DIST. NO. 8				ILLINOIS FED. AID PROJECT CONTRACT NO. 76022

Non-staining gray one component non-sag elastomeric gun grade polyurethane sealant meeting the requirements of ASTM C-920, Type S, Grade NS, Class 25. Use T with a 5/8" backer rod.

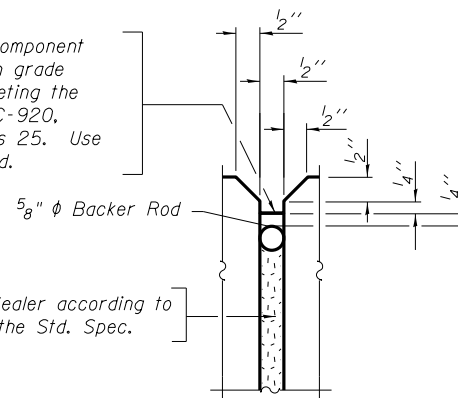

1/2" Silicone Joint Sealer according to Article 1051.07 of the Std. Spec.

LONGITUDINAL JOINT DETAILS

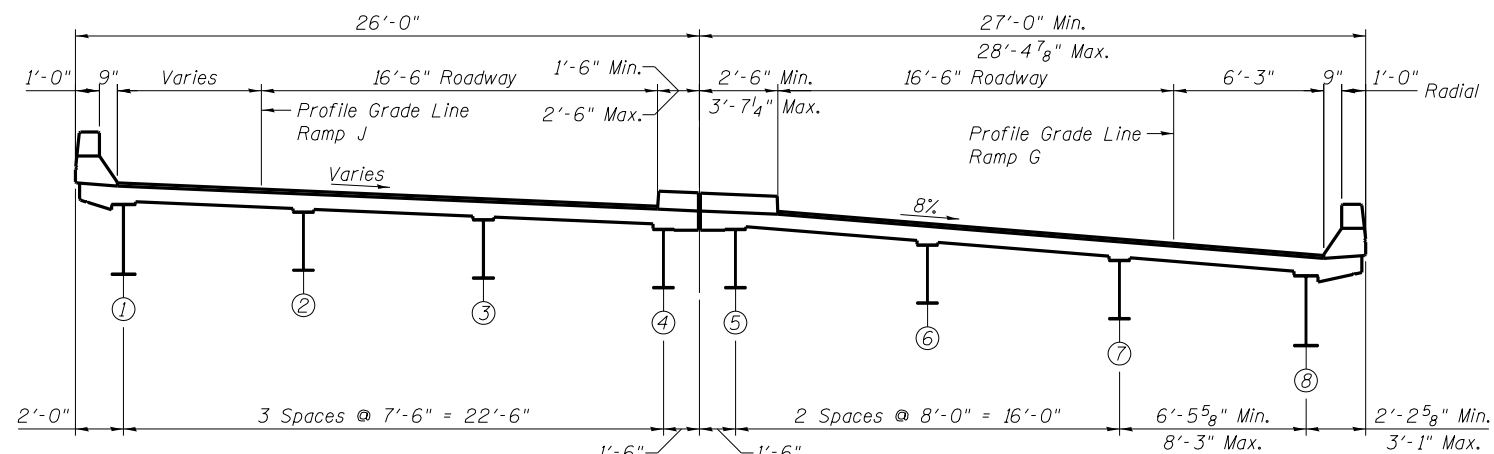

SN 082-0196 SPAN 1 CROSS SECTION
(Looking South)

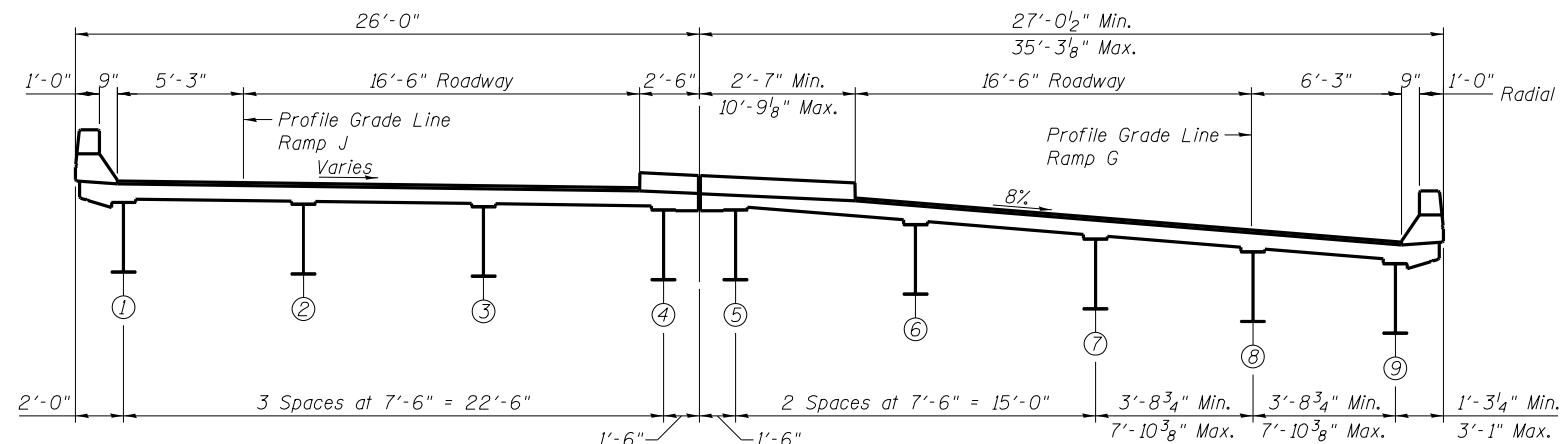

SN 082-0196 SPAN 2 CROSS SECTION
(Looking South)

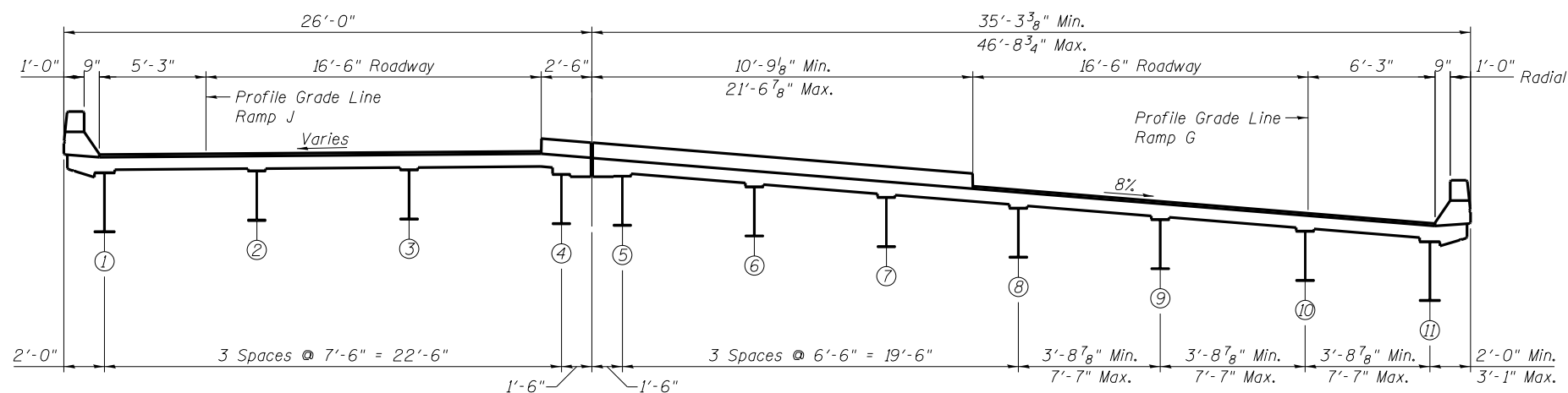

SN 082-0196 SPAN 3 CROSS SECTION
(Looking South)

BILL OF MATERIAL

Item	Unit	Total
Silicone Joint Sealer, 1/2"	Foot	147

BENTON & ASSOCIATES, INC.

FILE NAME = P:\10e2166-5\ Design\
Plans\ 0820196-76022-
006-Xsec.dgn

USER NAME =
PLOT SCALE =
PLOT DATE =

DESIGNED - MBH
CHECKED - SJH
DRAWN - MBH
CHECKED - SJH

REVISED - _____
REVISED - _____
REVISED - _____
REVISED - _____

**STATE OF ILLINOIS
DEPARTMENT OF TRANSPORTATION**

**SLAB CROSS SECTION
STRUCTURE NO. 082-0196**

SHEET NO. 6 OF 11 SHEETS

F.A.I. RTE.	SECTION	COUNTY	TOTAL SHEETS	SHEET NO.
64	82-2HB-1	ST. CLAIR	208	203
CONTRACT NO. 76022				
FED. ROAD DIST. NO. 8 ILLINOIS FED. AID PROJECT				

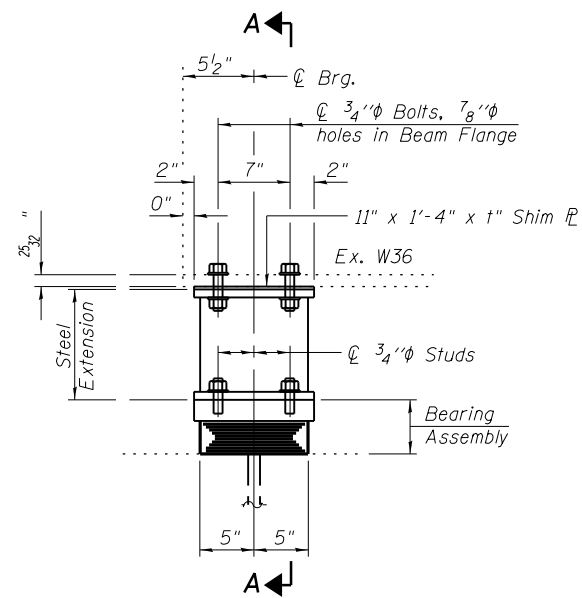

ELEVATION AT ABUTMENT

TYPE I ELASTOMERIC EXP. BRG.

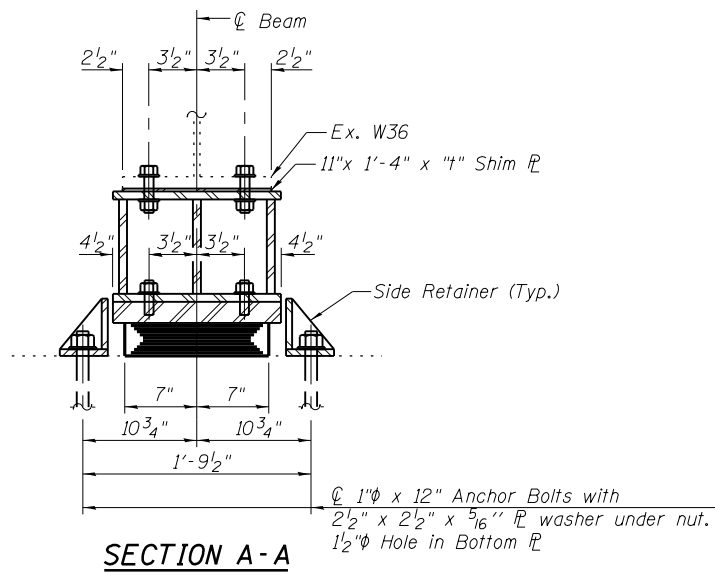

SECTION A-A

BEAM REACTIONS

R _D	(K)	36
R _L	(K)	43
Imp.	(K)	11
R (Total)	(K)	90

Notes:
 Diaphragm removal and reinstallation may be required to facilitate drilling holes. Cost included with Furnishing and Erecting Structural Steel.
 New steel extensions, shim plates and connection bolts are included with Furnishing and Erecting Structural Steel.
 Prior to ordering any material, the Contractor shall verify in the field all bearing height and shim thickness dimensions. Min. jack capacity = 27 Tons.
 Anchor bolts shall be ASTM F1554 all-thread (or an Engineer-approved alternate material) of the grade(s) and diameter(s) specified. ASTM A307 Grade C anchor bolts may be used in lieu of ASTM F1554 Grade 36 (Fy=36ksi). The corresponding specified grade of AASHTO M314 anchor bolts may be used in lieu of ASTM F1554.
 Anchor bolts at fixed bearings may be either cast in place or installed in holes drilled after the supported member is in place.
 Drilled and set anchor bolts shall be installed according to Article 521.06 of the Standard Specifications.
 Side retainers shall be included in the cost of Elastomeric Bearing Assembly, Type I.

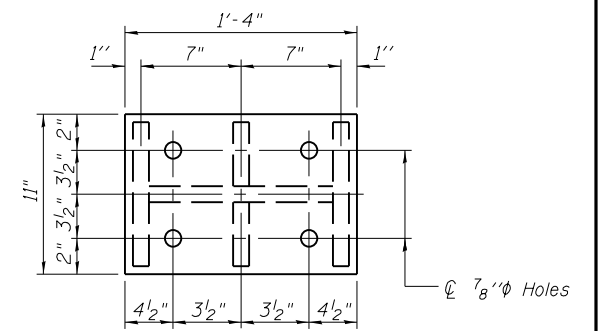

PLAN TOP AND BOTTOM PLATE

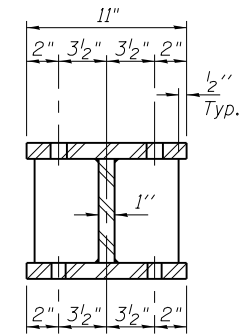

SECTION B-B

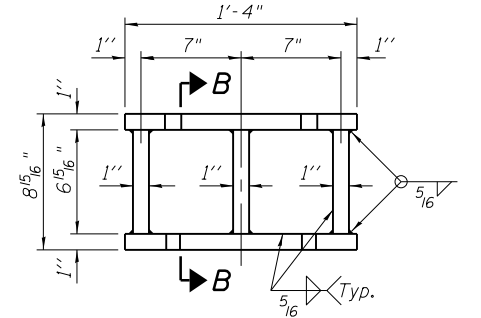

STEEL EXTENSION DETAIL

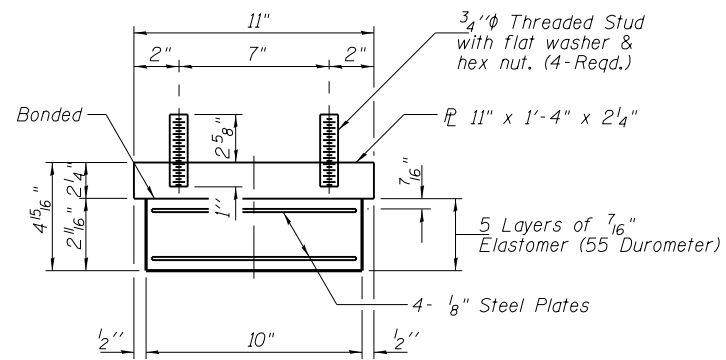

BEARING ASSEMBLY

Note:
 Shim plates shall not be placed under Bearing Assembly.

Bearing Shim Thickness - t (inches)									
Beams	1	2	3	4	5	6	7	8	9
So. Brg. Pier 2	5/8"	3/8"	--	1/2"	--	--	--	--	--

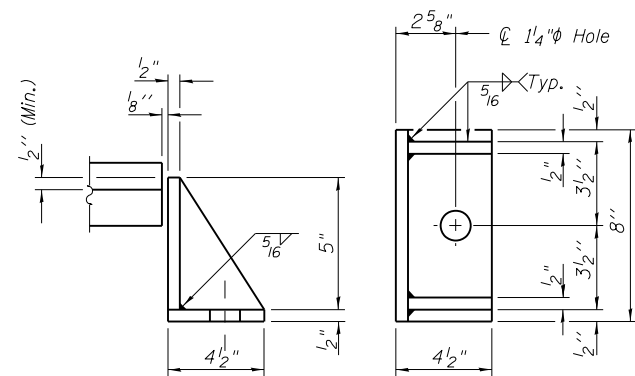

SIDE RETAINER

Equivalent rolled angle with stiffeners will be allowed in lieu of welded plates.

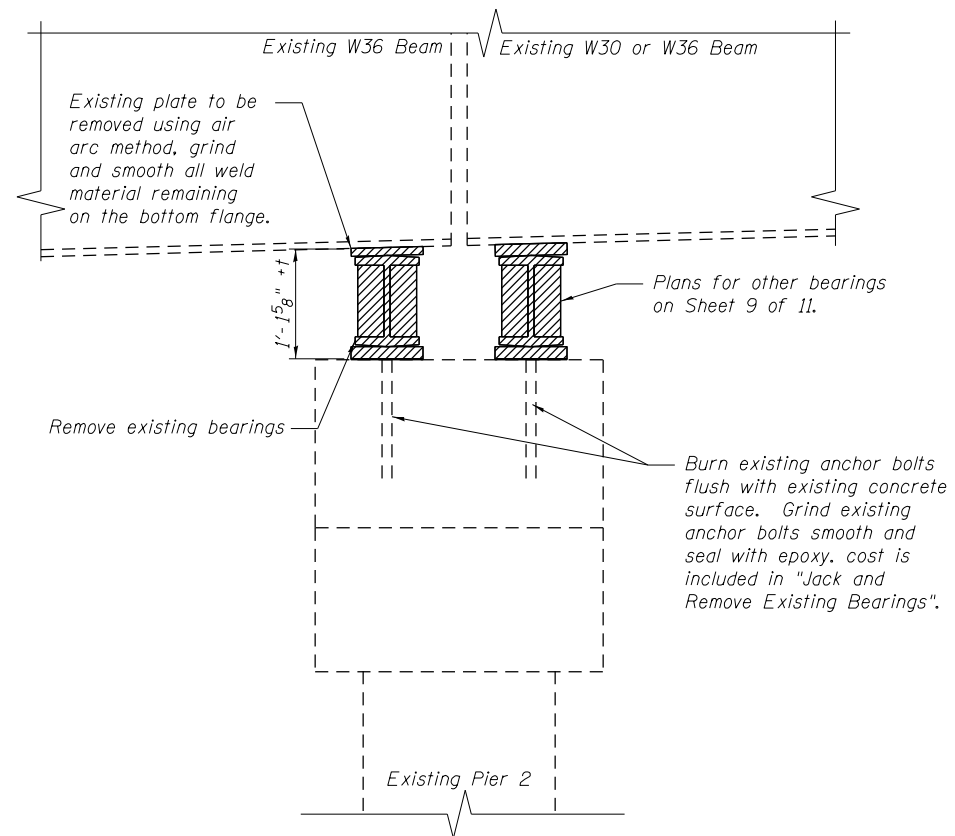

BILL OF MATERIAL

Item	Unit	Total
Elastomeric Bearing Assembly, Type I	Each	9
Jack and Remove Existing Bearings	Each	9
Furnishing and Erecting Structural Steel	Pound	1720
Anchor Bolts 1"φ	Each	18

TYI/REPS 12-03-2008
 BENTON & ASSOCIATES, INC.

FILE NAME = P:\10e2166-5\ Design\ Plans\ 0820166-76022-007-Bearings.dgn	USER NAME =	DESIGNED - MBH	REVISED - 10/3/13
		CHECKED - SJH	REVISED -
	PLOT SCALE =	DRAWN - MBH	REVISED -
	PLOT DATE =	CHECKED - SJH	REVISED -

STATE OF ILLINOIS
 DEPARTMENT OF TRANSPORTATION

PIER NO. 2 SOUTH BEARING DETAILS
 STRUCTURE NO. 082-0196

SHEET NO. 7 OF 11 SHEETS

F.A.I. RTE.	SECTION	COUNTY	TOTAL SHEETS	SHEET NO.
64	82-2HB-1	ST. CLAIR	208	204
FED. ROAD DIST. NO. 8 ILLINOIS FED. AID PROJECT			CONTRACT NO. 76022	

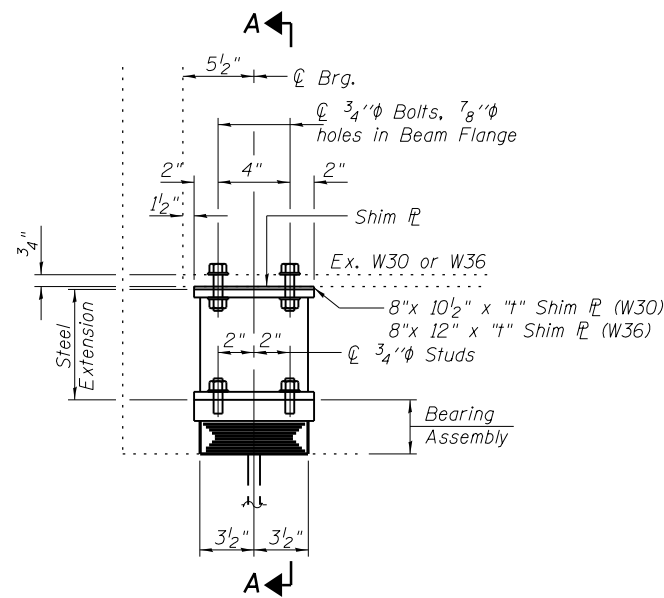

ELEVATION AT ABUTMENT

TYPE I ELASTOMERIC EXP. BRG.

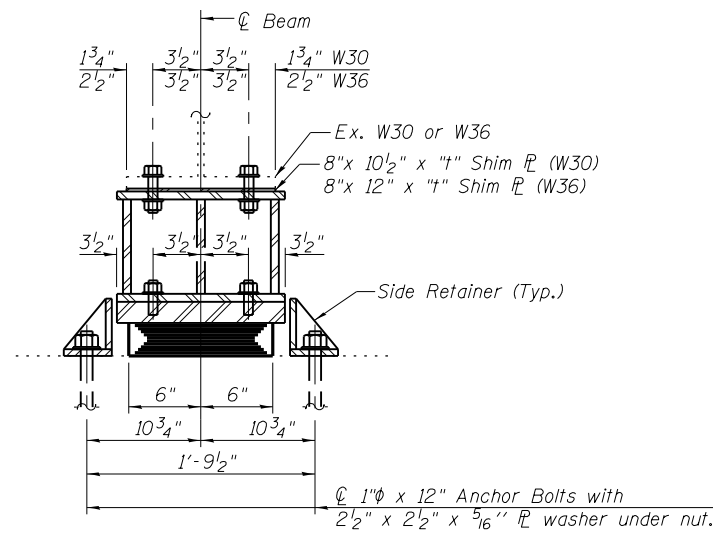

SECTION A-A

BEAM REACTIONS

R ₁	(K)	18
R ₂	(K)	38
Imp.	(K)	11
R (Total)	(K)	67

Notes:
 Diaphragm removal and reinstallation may be required to facilitate drilling holes. Cost included with Furnishing and Erecting Structural Steel.
 New steel extensions, shim plates and connection bolts are included with Furnishing and Erecting Structural Steel.
 Prior to ordering any material, the Contractor shall verify in the field all bearing height and shim thickness dimensions. Min. jack capacity = Tons.
 Anchor bolts shall be ASTM F1554 all-thread (or an Engineer-approved alternate material) of the grade(s) and diameter(s) specified. ASTM A307 Grade C anchor bolts may be used in lieu of ASTM F1554 Grade 36 (Fy=36ksi). The corresponding specified grade of AASHTO M314 anchor bolts may be used in lieu of ASTM F1554.
 Anchor bolts at fixed bearings may be either cast in place or installed in holes drilled after the supported member is in place.
 Drilled and set anchor bolts shall be installed according to Article 521.06 of the Standard Specifications.
 Side retainers shall be included in the cost of Elastomeric Bearing Assembly, Type I.

Bearing Shim PL Thickness - t (inches)								
Beams	1	2	3	4	5	6	7	8
So. Brg. Pier 1	--	--	--	--	--	--	--	--

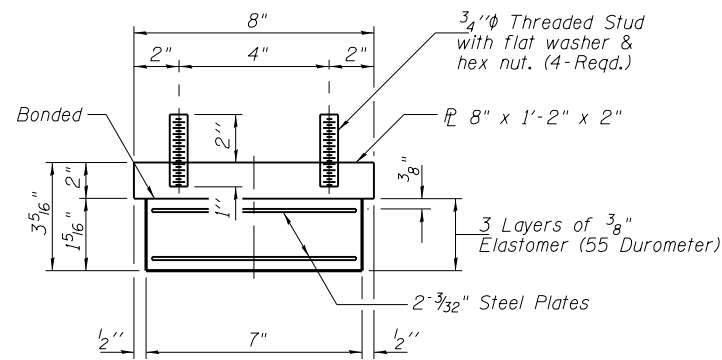

BEARING ASSEMBLY

Note:
 Shim plates shall not be placed under Bearing Assembly.

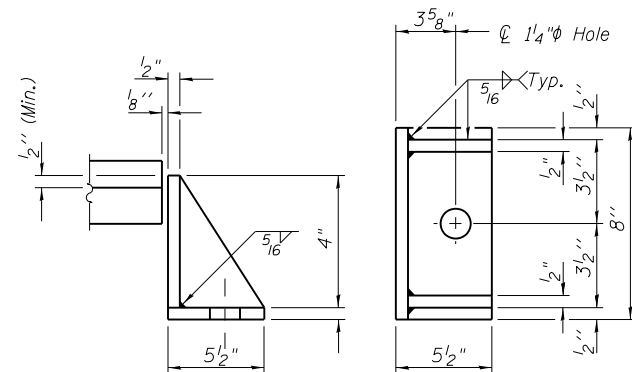

SIDE RETAINER

Equivalent rolled angle with stiffeners will be allowed in lieu of welded plates.

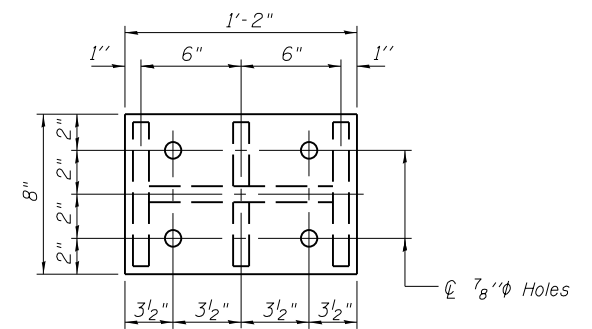
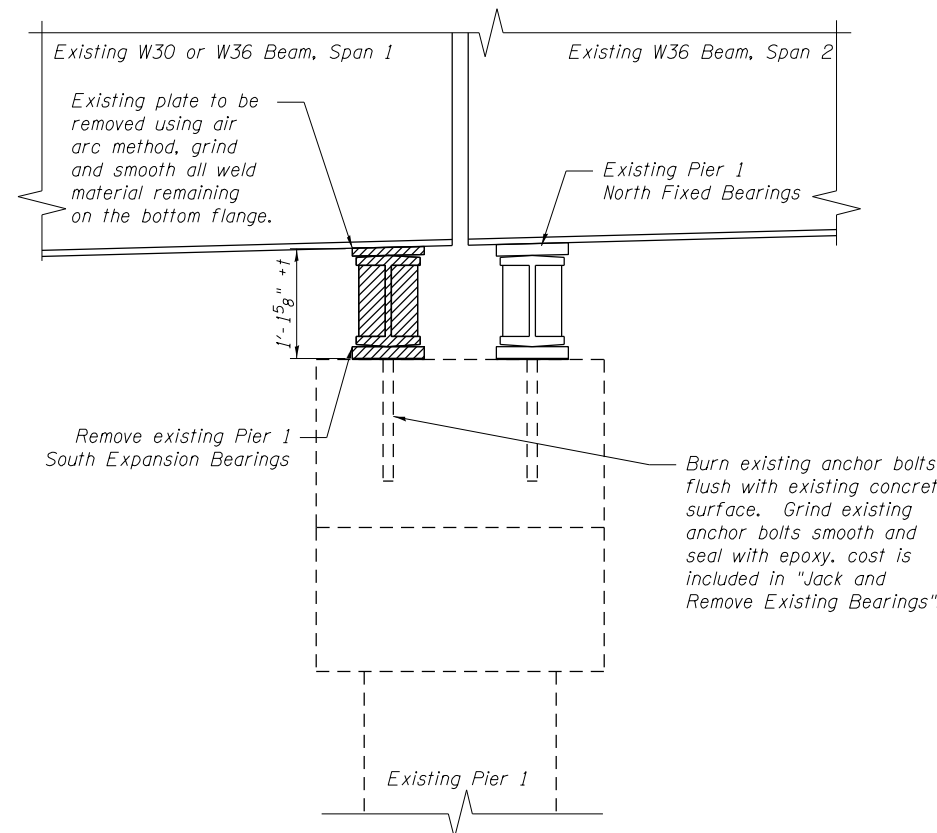

PLAN TOP AND BOTTOM PLATE

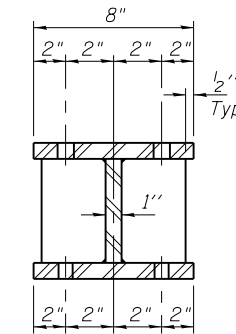

SECTION B-B

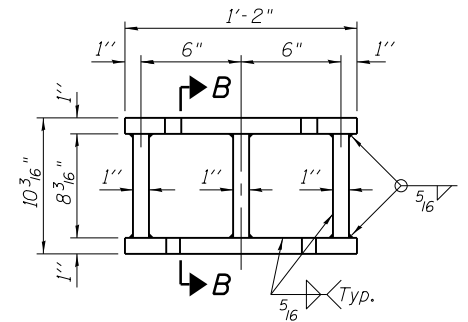

STEEL EXTENSION DETAIL

BILL OF MATERIAL

Item	Unit	Total
Elastomeric Bearing Assembly, Type I	Each	8
Jack and Remove Existing Bearings	Each	8
Furnishing and Erecting Structural Steel	Pound	1110
Anchor Bolts 1 1/4"	Each	16

TYI/REPS 12-03-2008
 BENTON & ASSOCIATES, INC.

FILE NAME = P:\10e2166-5\ Design\ Plans\ 0820166-76022-008-Bearings.dgn	USER NAME =	DESIGNED - MBH	REVISED - 10/3/13
		CHECKED - SJH	REVISED -
	PLOT SCALE =	DRAWN - MBH	REVISED -
	PLOT DATE =	CHECKED - SJH	REVISED -

STATE OF ILLINOIS
 DEPARTMENT OF TRANSPORTATION

PIER NO. 1 SOUTH BEARING DETAILS
 STRUCTURE NO. 082-0196

SHEET NO. 8 OF 11 SHEETS

F.A.I. RTE. 64	SECTION 82-2HB-1	COUNTY ST. CLAIR	TOTAL SHEETS 208	SHEET NO. 205
CONTRACT NO. 76022				
FED. ROAD DIST. NO. 8 ILLINOIS FED. AID PROJECT				

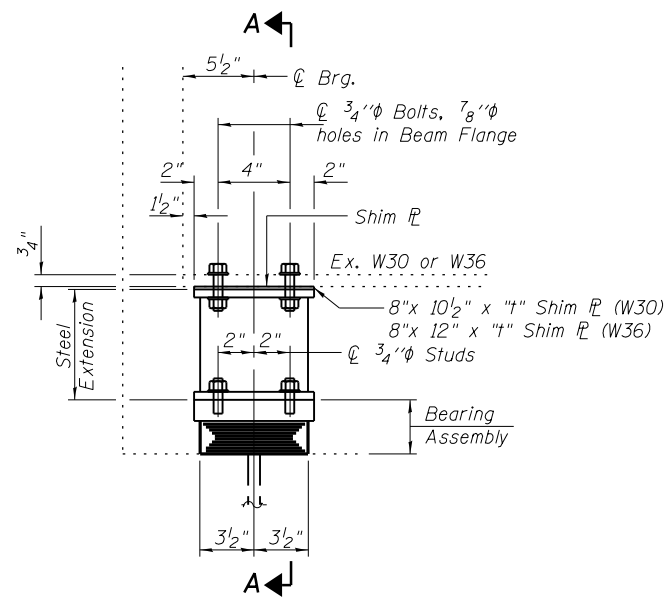

ELEVATION AT ABUTMENT

TYPE I ELASTOMERIC EXP. BRG.

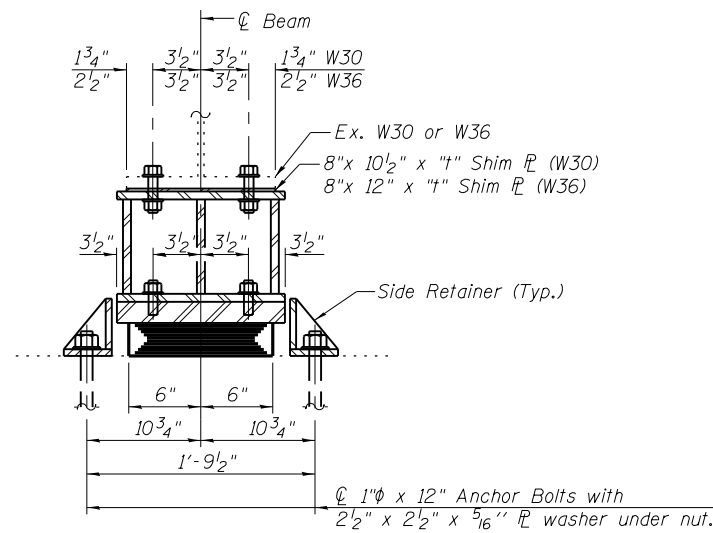

SECTION A-A

BEAM REACTIONS

R ₁	(K)	19
R ₂	(K)	37
Imp.	(K)	11
R (Total)	(K)	67

Notes:
 Diaphragm removal and reinstallation may be required to facilitate drilling holes. Cost included with Furnishing and Erecting Structural Steel.
 New steel extensions, shim plates and connection bolts are included with Furnishing and Erecting Structural Steel.
 Prior to ordering any material, the Contractor shall verify in the field all bearing height and shim thickness dimensions. Min. jack capacity = Tons.
 Anchor bolts shall be ASTM F1554 all-thread (or an Engineer-approved alternate material) of the grade(s) and diameter(s) specified. ASTM A307 Grade C anchor bolts may be used in lieu of ASTM F1554 Grade 36 (Fy=36ksi). The corresponding specified grade of AASHTO M314 anchor bolts may be used in lieu of ASTM F1554.
 Anchor bolts at fixed bearings may be either cast in place or installed in holes drilled after the supported member is in place.
 Drilled and set anchor bolts shall be installed according to Article 521.06 of the Standard Specifications.
 Side retainers shall be included in the cost of Elastomeric Bearing Assembly, Type I.

		Bearing Shim P Thickness - t (inches)										
Beams		1	2	3	4	5	6	7	8	9	10	11
Q No.	Brg. Pier 2	5/8"	3/8"	--	1/2"	--	--	--	--	--	--	1/8"

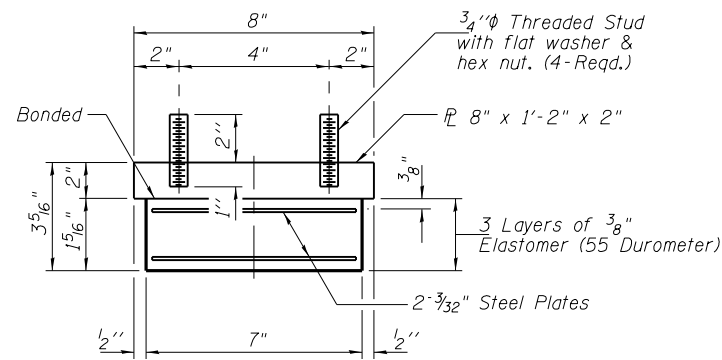

BEARING ASSEMBLY

Note:
 Shim plates shall not be placed under Bearing Assembly.

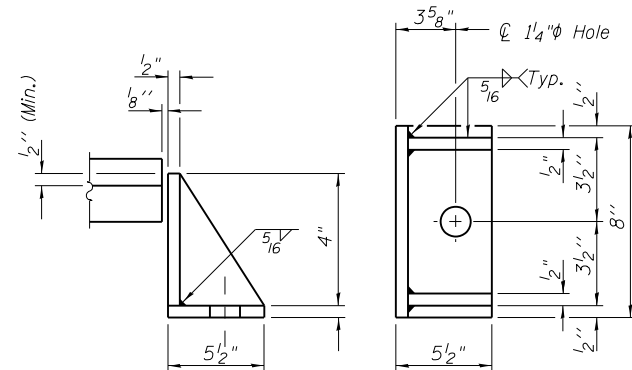

SIDE RETAINER

Equivalent rolled angle with stiffeners will be allowed in lieu of welded plates.

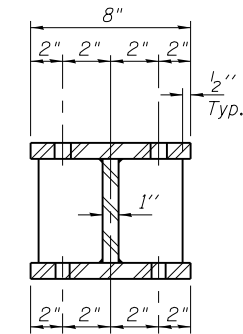

SECTION B-B

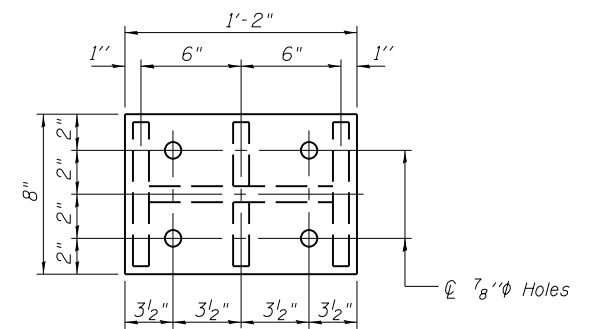

PLAN TOP AND BOTTOM PLATE

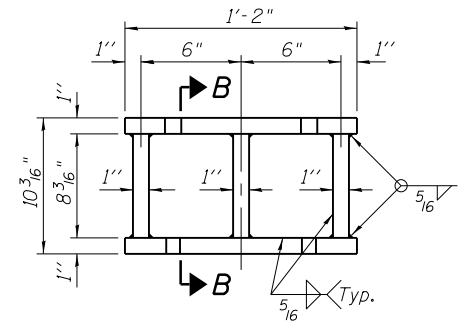

STEEL EXTENSION DETAIL

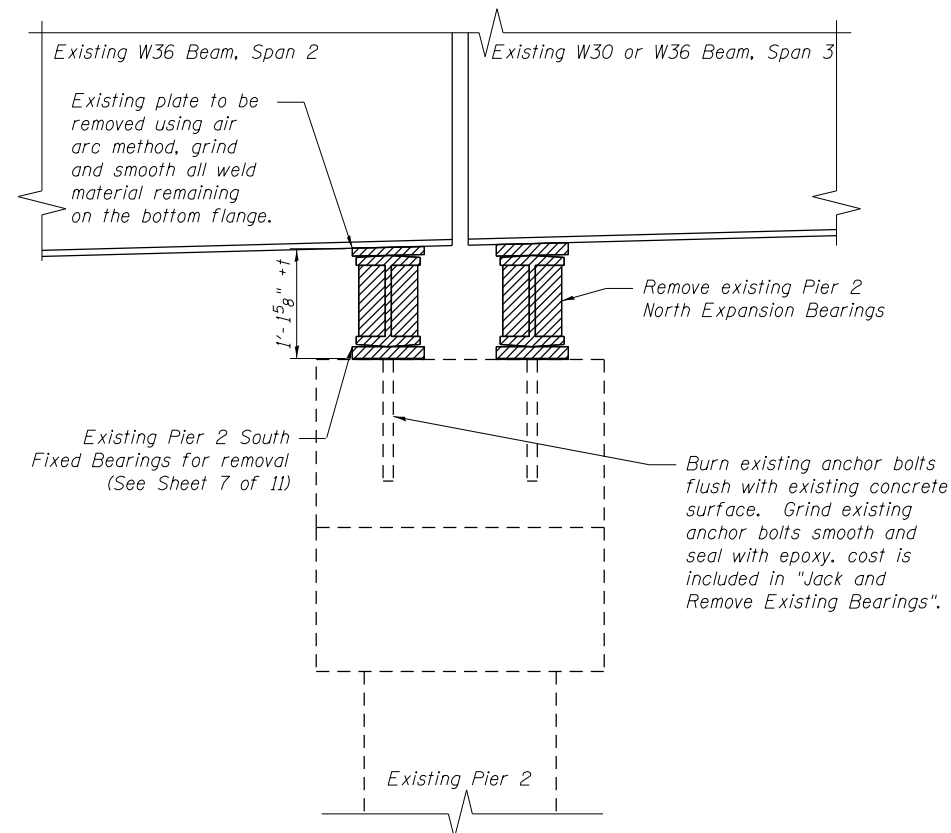

BILL OF MATERIAL

Item	Unit	Total
Elastomeric Bearing Assembly, Type I	Each	11
Jack and Remove Existing Bearings	Each	11
Furnishing and Erecting Structural Steel	Pound	1570
Anchor Bolts 1"φ	Each	22

TYI/REPS 12-03-2008
 BENTON & ASSOCIATES, INC.

FILE NAME = P:\10e2166-5\ Design\ Plans\ 0820166-76022-009-Bearings.dgn	USER NAME =	DESIGNED - MBH	REVISED - 10/3/13
		CHECKED - SJH	REVISED -
	PLOT SCALE =	DRAWN - MBH	REVISED -
	PLOT DATE =	CHECKED - SJH	REVISED -

STATE OF ILLINOIS
 DEPARTMENT OF TRANSPORTATION

PIER NO. 2 NORTH BEARING DETAILS
 STRUCTURE NO. 082-0196

SHEET NO. 9 OF 11 SHEETS

F.A.I. RTE. 64	SECTION 82-2HB-1	COUNTY ST. CLAIR	TOTAL SHEETS 208	SHEET NO. 206
CONTRACT NO. 76022			FED. ROAD DIST. NO. 8 ILLINOIS FED. AID PROJECT	

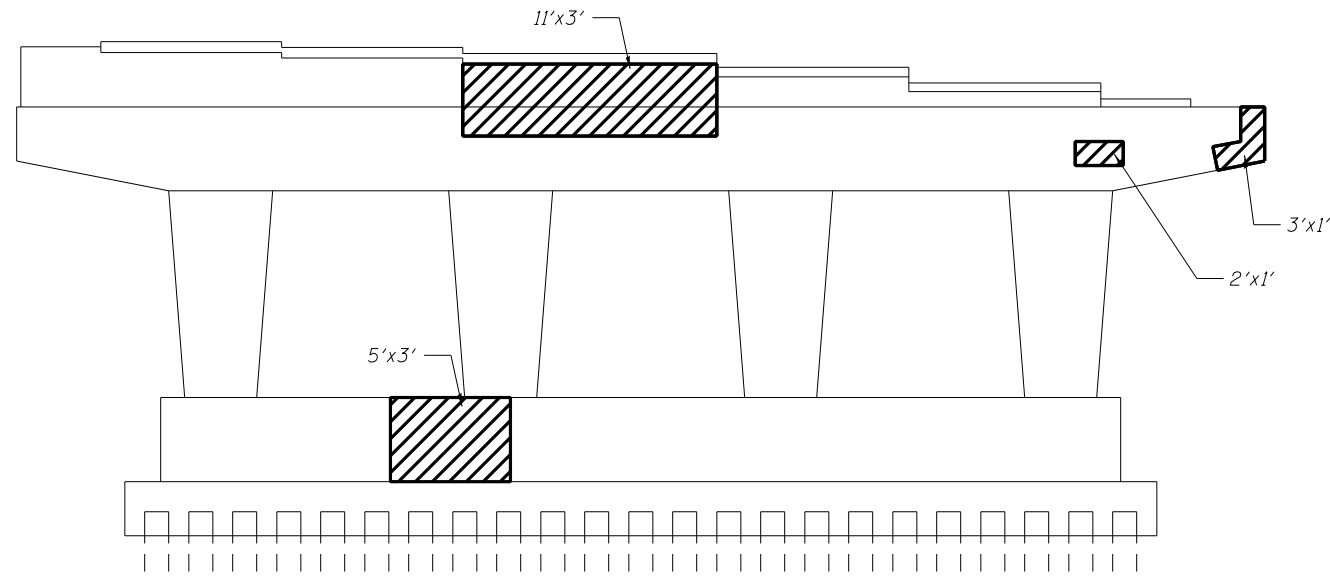

SOUTH PIER
(Looking South)

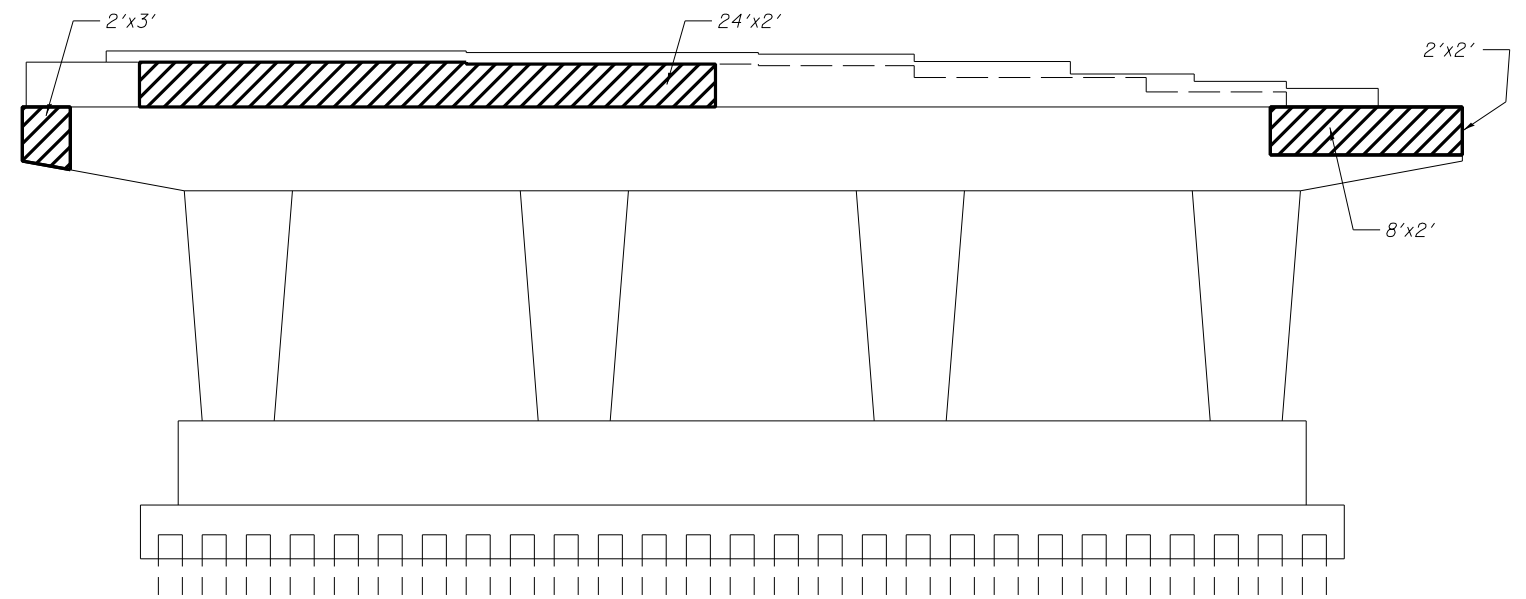

NORTH PIER
(Looking South)

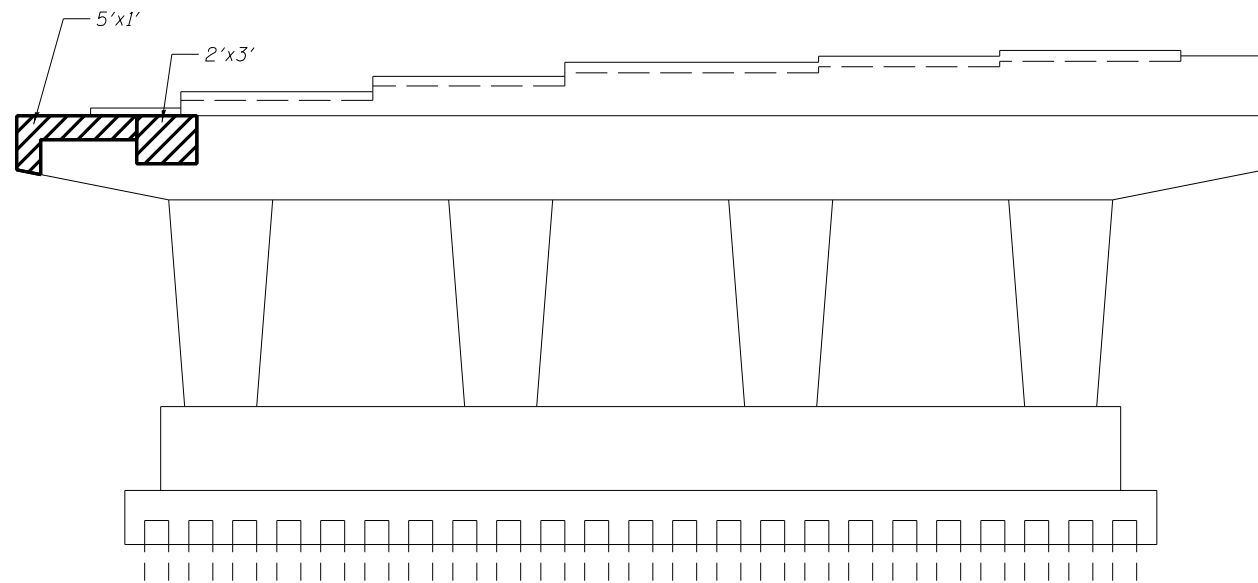

SOUTH PIER
(Looking North)

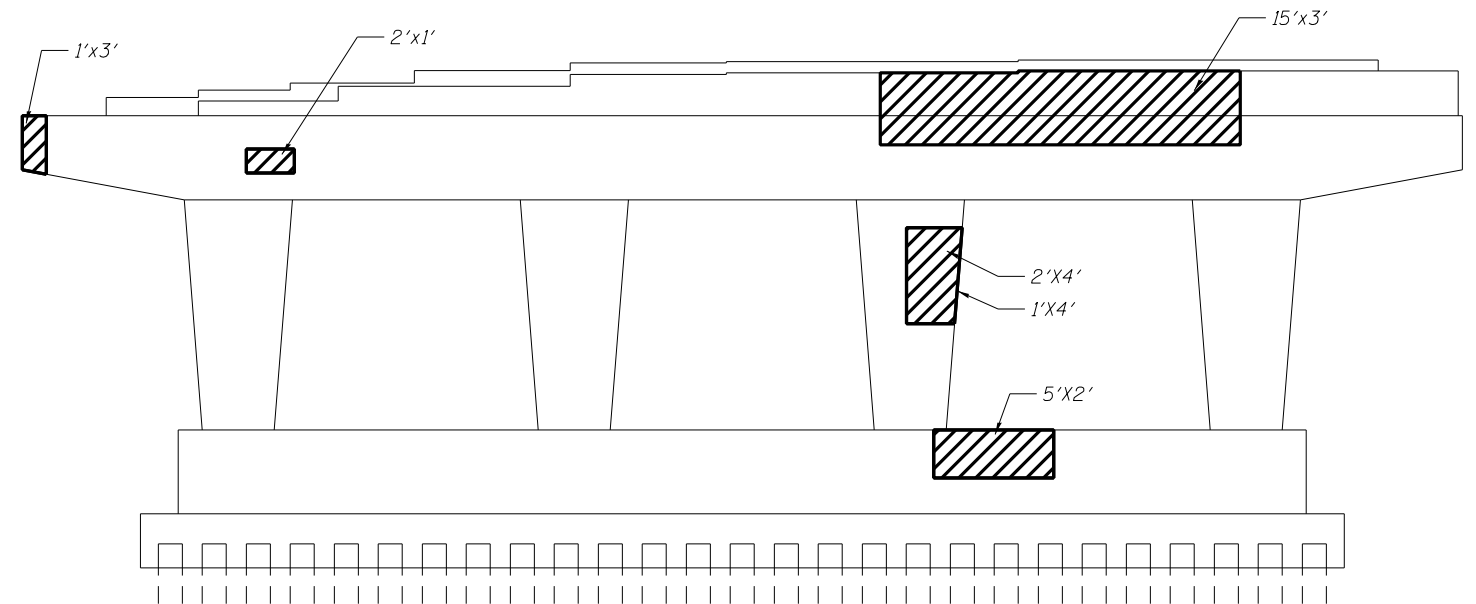

NORTH PIER
(Looking North)

LEGEND

Area of Structural Concrete Repair

BILL OF MATERIAL

Item	Unit	Total
Structural Repair of Concrete (Depth <= 5")	Sq. Ft.	210

BENTON & ASSOCIATES, INC.

FILE NAME = P:\10e2166-5\ Design\ Plans\ 082-0196-76022-010- Piers.dgn	USER NAME =	DESIGNED - MBH	REVISED -
		CHECKED - SJH	REVISED -
	PLOT SCALE =	DRAWN - MBH	REVISED -
	PLOT DATE =	CHECKED - SJH	REVISED -

STATE OF ILLINOIS
DEPARTMENT OF TRANSPORTATION

SUBSTRUCTURE REPAIRS
STRUCTURE NO. 082-0196

SHEET NO. 10 OF 11 SHEETS

F.A.I. RTE. 64	SECTION 82-3HB	COUNTY ST. CLAIR	TOTAL SHEETS 208	SHEET NO. 207
CONTRACT NO. 76022				
FED. ROAD DIST. NO. 8 ILLINOIS FED. AID PROJECT				

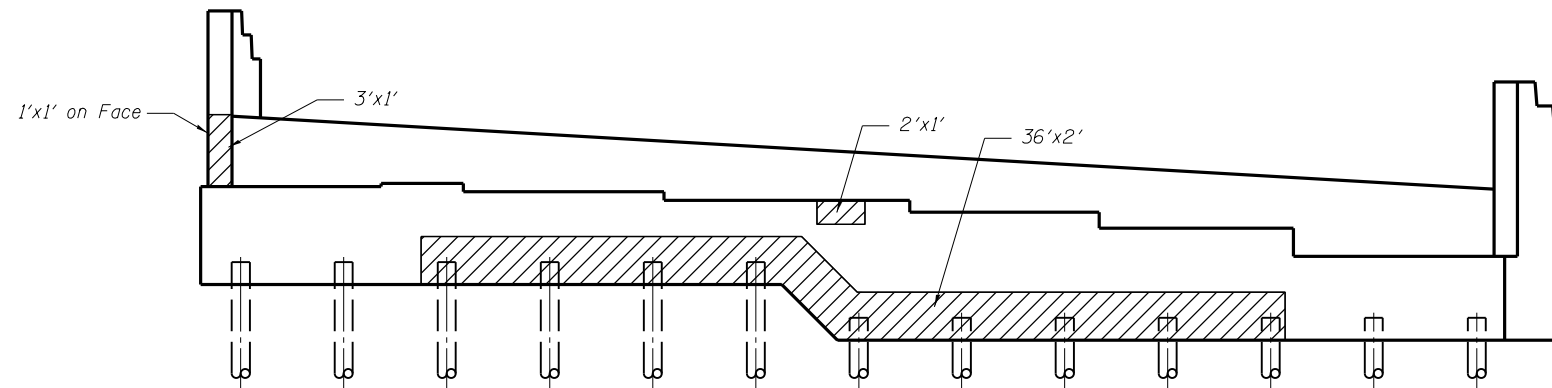

SOUTH ABUTMENT
(Looking South)

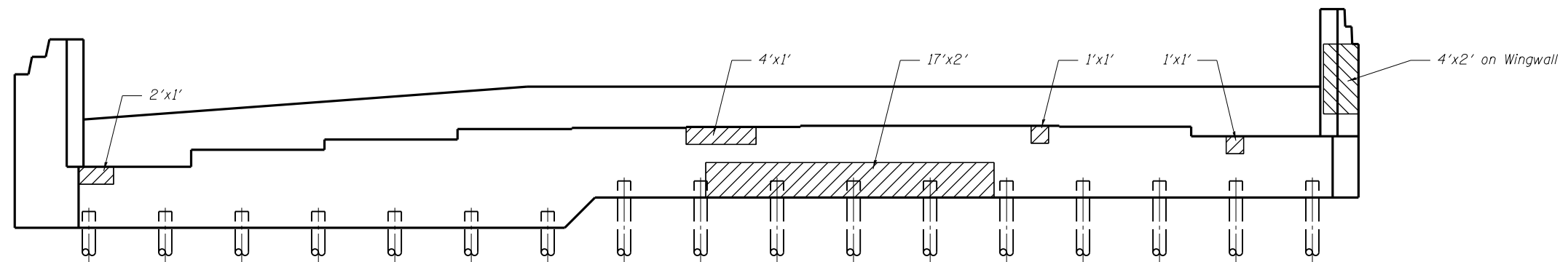

NORTH ABUTMENT
(Looking North)

LEGEND

 Area of Structural Concrete Repair

BILL OF MATERIAL

Item	Unit	Total
Structural Repair of Concrete (Depth <= 5")	Sq. Ft.	128

BENTON & ASSOCIATES, INC.

FILE NAME = P:\10e2166-5\ Design\ Plans\ 082-0196-76022-011- Abut.dgn	USER NAME =	DESIGNED - MBH	REVISED - _____
		CHECKED - SJH	REVISED - _____
	PLOT SCALE =	DRAWN - MBH	REVISED - _____
	PLOT DATE =	CHECKED - SJH	REVISED - _____

**STATE OF ILLINOIS
DEPARTMENT OF TRANSPORTATION**

**ABUTMENT REPAIRS
STRUCTURE NO. 082-0196**

SHEET NO. 11 OF 11 SHEETS

F.A.I. RTE.	SECTION	COUNTY	TOTAL SHEETS	SHEET NO.
64	82-3HB-1	ST. CLAIR	208	208
CONTRACT NO. 76022				
FED. ROAD DIST. NO. 8 ILLINOIS FED. AID PROJECT				