

ANCHOR BOLT CAGE

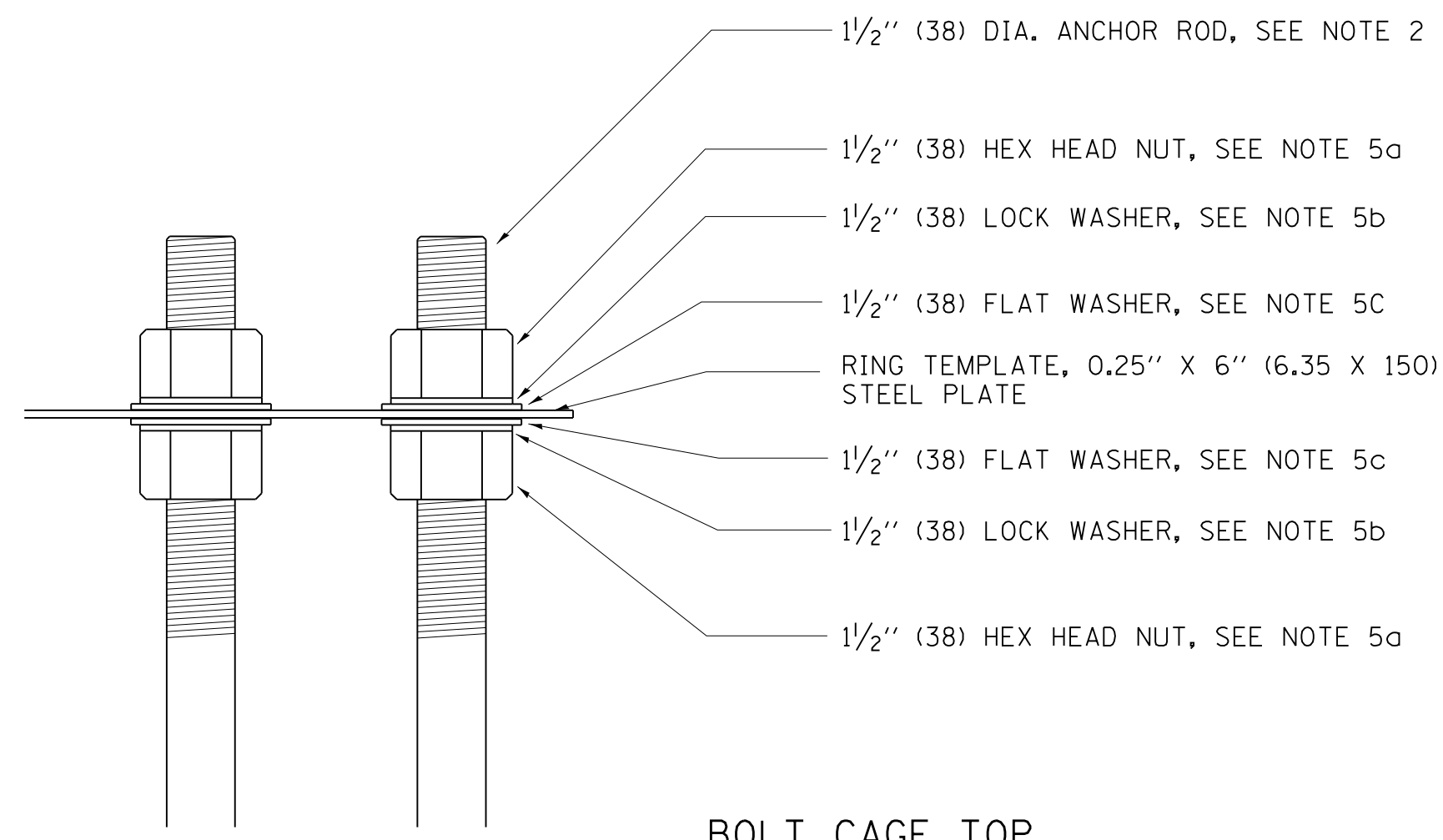

BOLT CAGE TOP

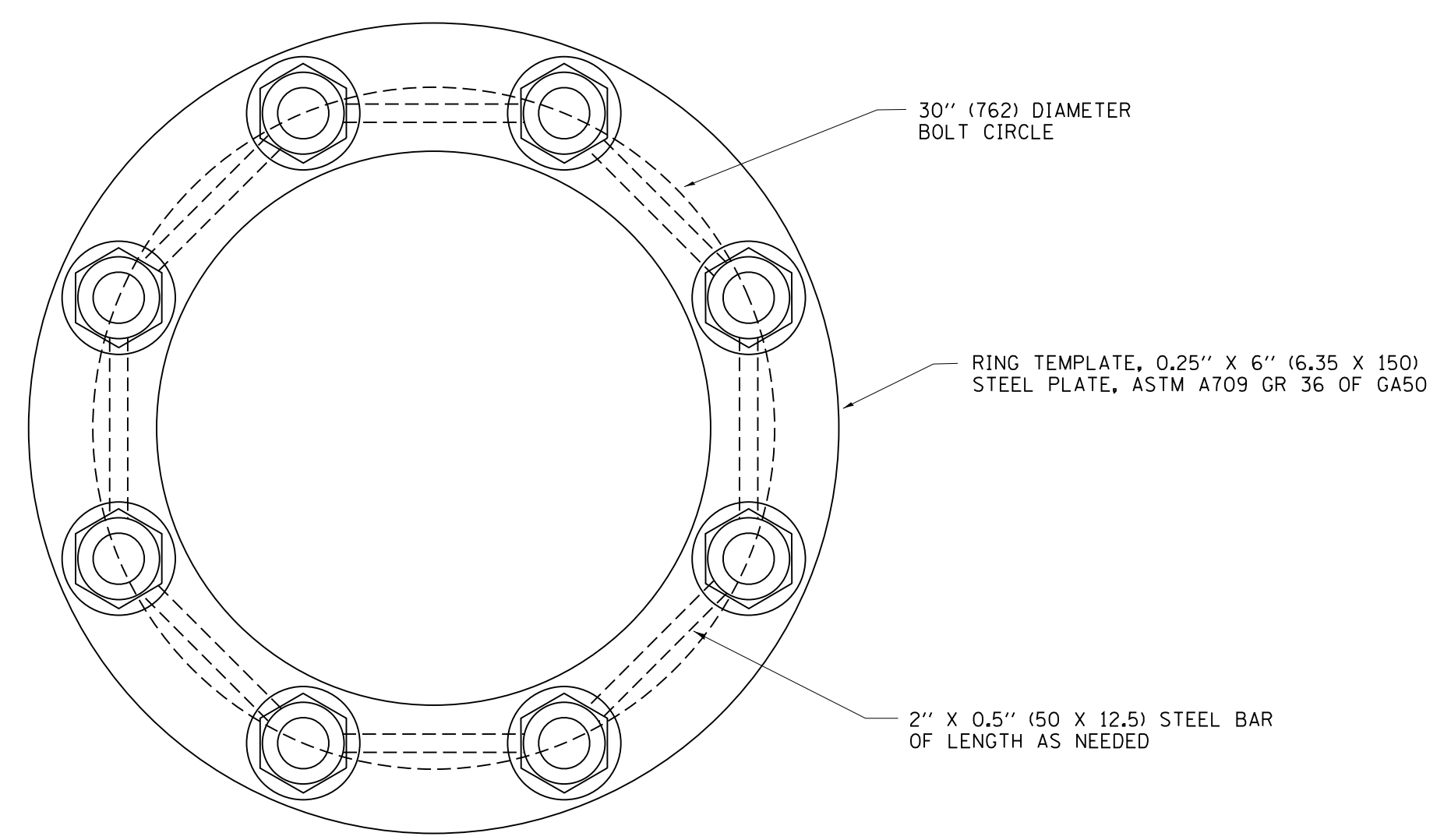

SECTION A-A

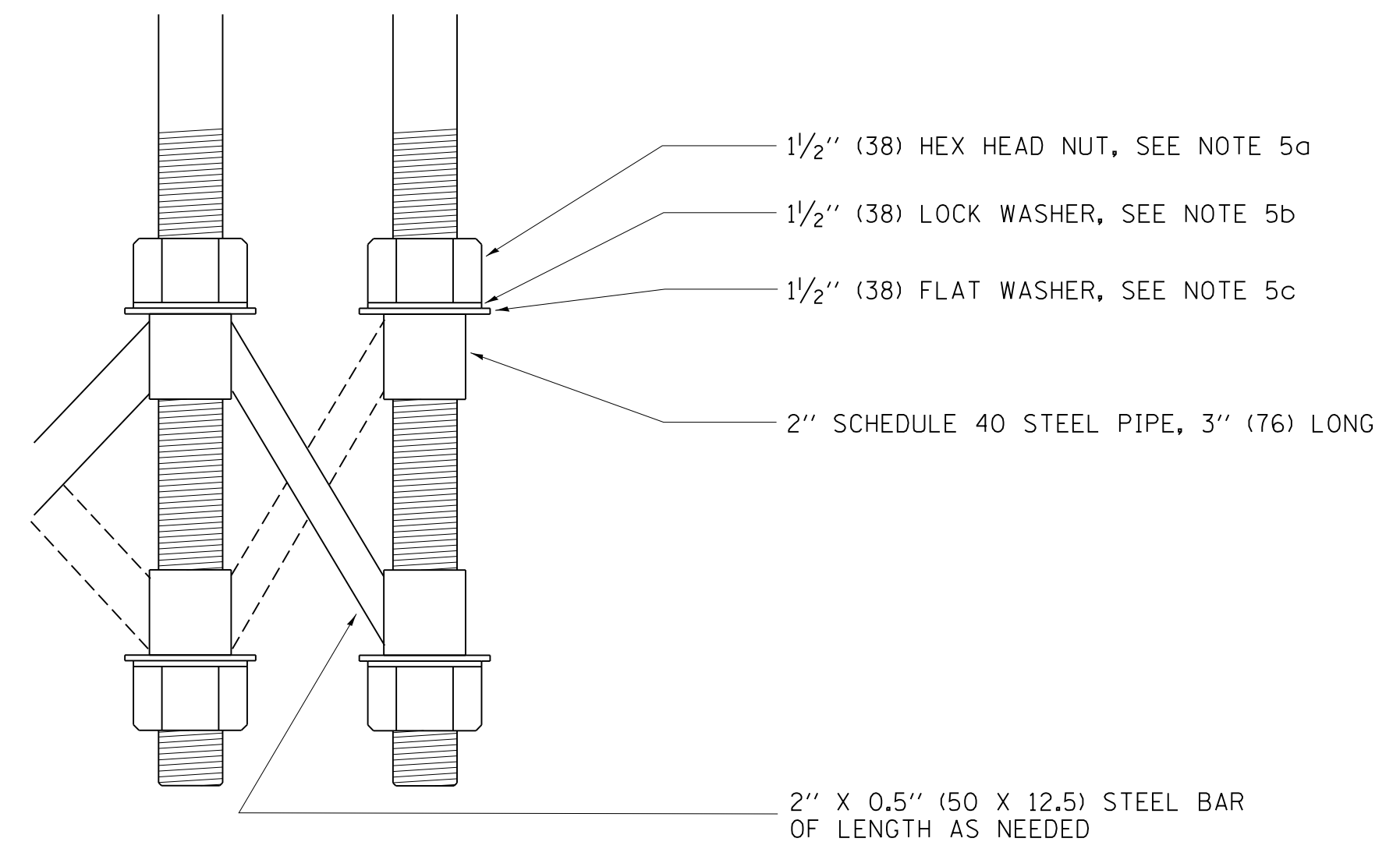

BOLT CAGE BOTTOM

NOTES

1. ALL DIMENSIONS IN INCHES (MILLIMETERS) UNLESS OTHERWISE SHOWN
2. ANCHOR RODS SHALL BE STRAIGHT AND SHALL BE ACCORDING TO AASHTO M 314 OR ASTM F1554, GRADE 725 (GRADE 105) AND GALVANIZED ACCORDING TO ARTICLE 1006.09.
3. ANCHOR ROD INFORMATION SHALL BE SUBMITTED FOR APPROVAL AND SHALL BE FULLY COORDINATED WITH TOWER MANUFACTURERS REQUIREMENTS.
4. CUT NUTS, OR JAM NUTS, ARE NOT ALLOWED
5. ANCHOR ROD CAGE HARDWARE SHALL BE IN ACCORDANCE WITH THE FOLLOWING:
 - a) 1.5 (38) HEX HEAD NUTS
AASHTO M291, GRADE C, C3, D ,DH OR DH3
HOT DIPPED GALVANIZED AASHTO M 232
 - b) 1.5 (38) HELICAL LOCK WASHERS
ANSI/ASME B18.21.1
I.D. 1.504 - 1.524
O.D. 2.159 MAX.
WIDTH 0.292 MIN.
THICKNESS 0.375 MIN.
HARDNESS 26-45 ROCKWELL C
HOT DIPPED GALVANIZED AASHTO M232
 - c) 1.5 (38) FLAT WASHERS
AASHTO M293
O.D. 2.75
I.D. 1.56
THICKNESS 0.16 - 0.25
HARDNESS 26-45 ROCKWELL C.
HOT DIPPED GALVANIZED AASHTO M232
6. THE SHAFT LENGTHS SHALL BE BASED ON SOIL BORINGS IN THE PLANS AND OR A DETERMINATION OF SOIL CONDITIONS BY THE ENGINEER.
7. ALL FOUNDATION REINFORCEMENT STEEL SHALL BE EPOXY COATED.
8. THE FOUNDATION SHALL BE POURED MONOLITHICALLY AND SHALL HAVE NO CONSTRUCTION JOINTS.
9. ANCHOR RODS AND ALL ASSOCIATED HARDWARE ARE SHOWN AS MINIMUMS. SIZING SHALL BE DETERMINED BY THE TOWER MANUFACTURER AND APPROVED BY THE ENGINEER. EACH FOUNDATION SHALL HAVE A MINIMUM OF 8 ANCHOR RODS.

FILE NAME = c:\pwork\work\pwork\bauder1\d0108315\be501.dgn	USER NAME = bauder1	DESIGNED - DRAWN -	REVISED - R. TOMSONS 04-22-02 REVISED - R. TOMSONS 03-12-10
PLOT SCALE = 50.000 1 / in.	CHECKED -	REVISED - R. TOMSONS 09-02-10	REVISED - R. TOMSONS 02-27-13
PLOT DATE = 2/27/2013	DATE -		

**STATE OF ILLINOIS
DEPARTMENT OF TRANSPORTATION**

HIGH MAST LIGHT TOWER			
90 FT TO 110 FT (27 m TO 34 m) FOUNDATION DETAIL			
SCALE: NONE	SHEET NO. 2 OF 2 SHEETS	STA.	TO STA.

F.A. RTE.	SECTION	COUNTY	TOTAL SHEETS	SHEET NO.
	BE-501			
FED. ROAD DIST. NO. 1		ILLINOIS FED. AID PROJECT		