

THE CULVERT TIES SHALL BE INCLUDED IN THE COST OF THE CONCRETE PIPE CULVERTS OR THE PRECAST CONCRETE BOX CULVERT. THE MECHANICAL TIES SHALL BE ON THE OUTSIDE OF THE CULVERT. THE NUTS AND WASHERS SHALL BE PLACED ON THE INSIDE OF THE CULVERT AND COVERED WITH MASTIC JOINT SEALER CONFORMING TO ARTICLES 1055 OR 1056 IN THE STANDARD SPECIFICATIONS FOR ROAD AND BRIDGE CONSTRUCTION.

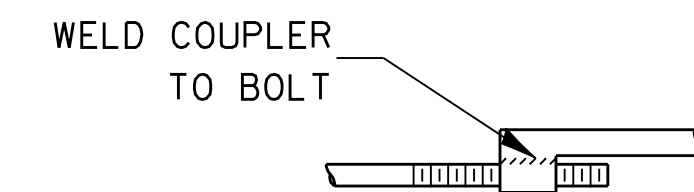

TOP VIEW

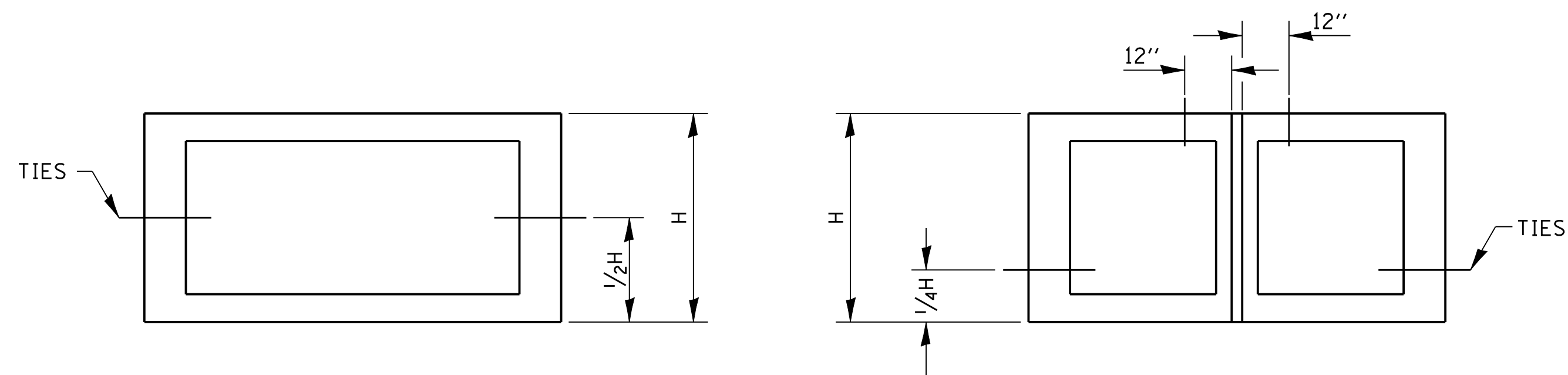
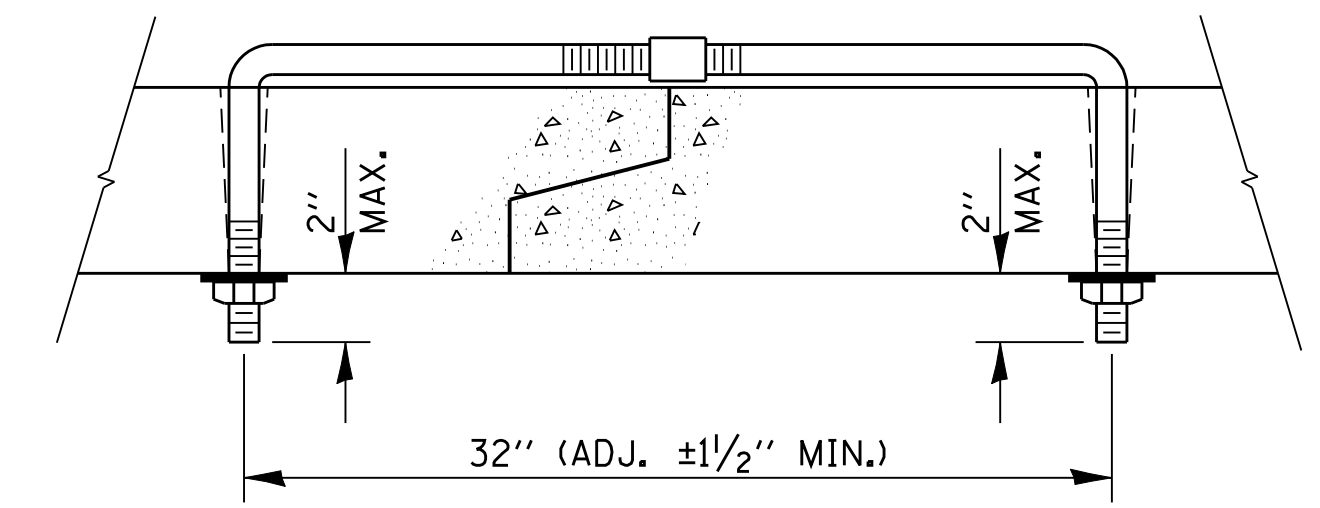

ADJUSTABLE TIE

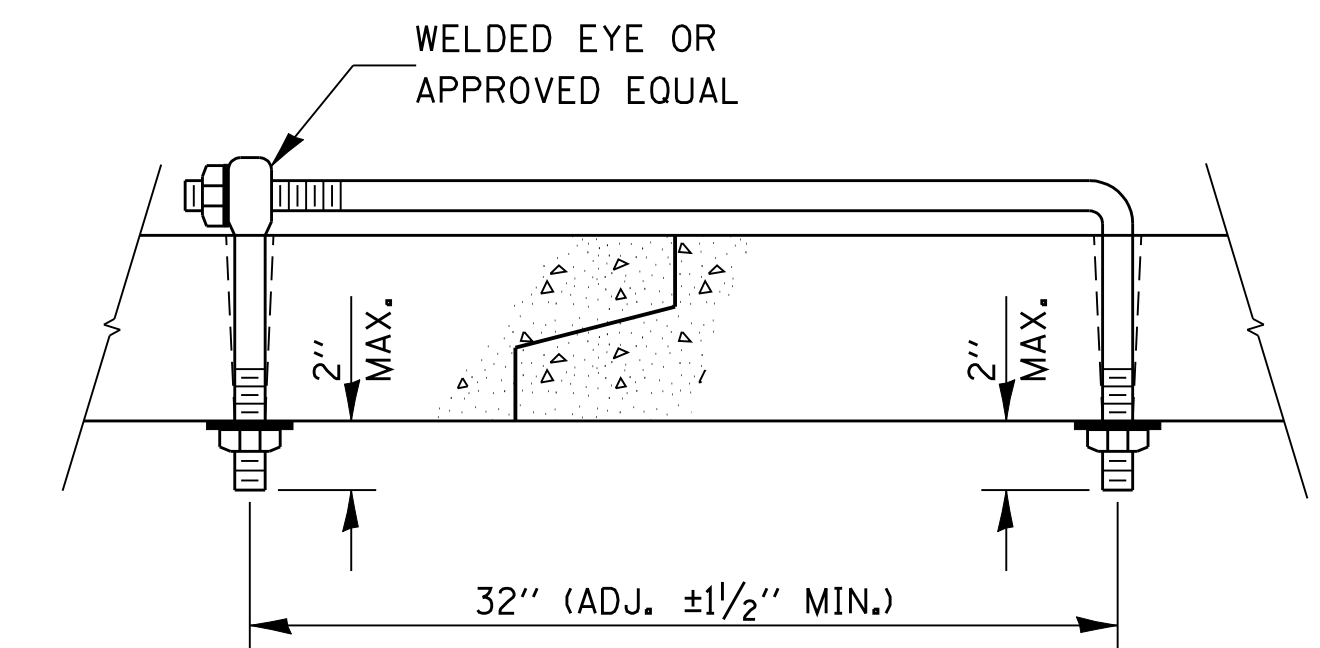

EYE BOLT TIE

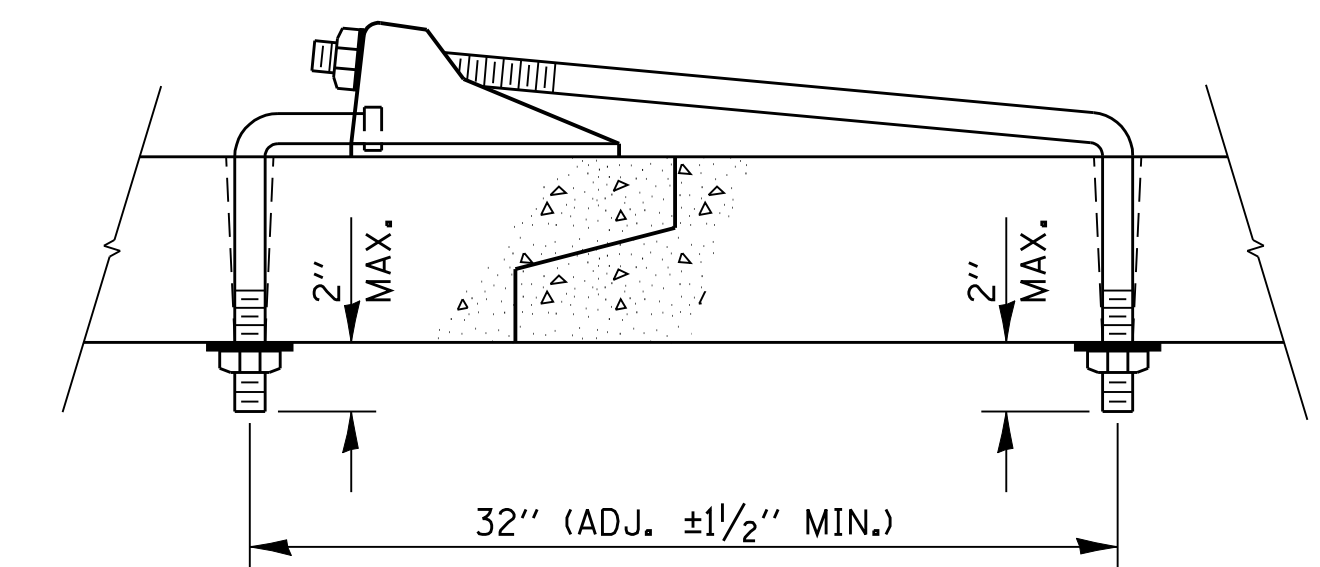

CANOPY TIE

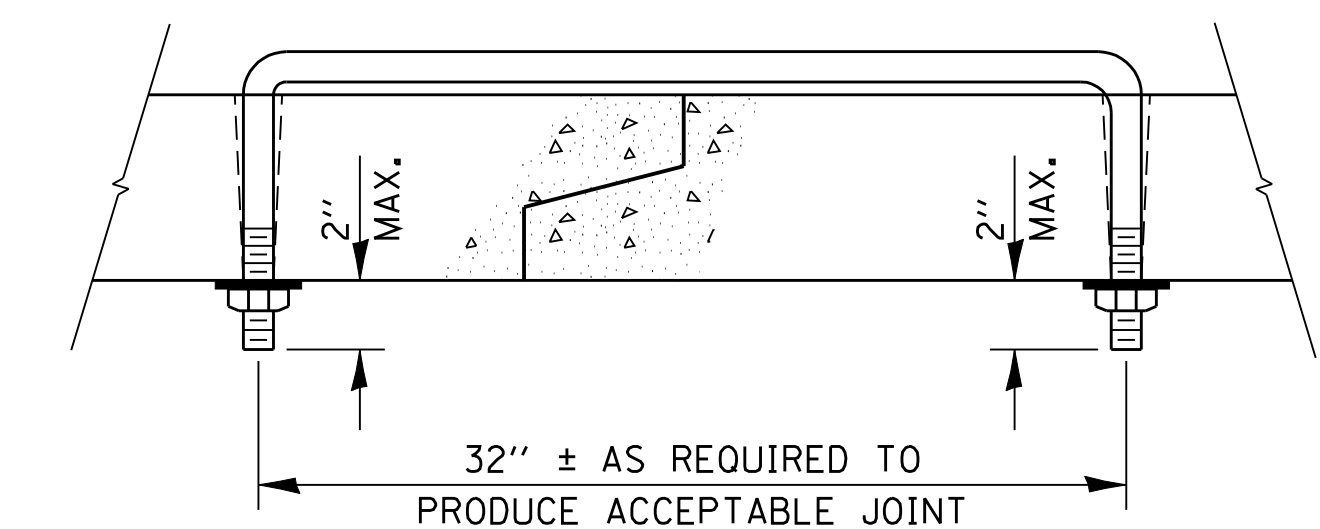

U BOLT TIE

PLACEMENT OF HOLES		
BOX CULVERT FEET	PIPE SIZE INCHES	THREAD DIAMETER INCHES
	12	5/8 ROLLED THREADS (SEE NOTE 4)
	15	
	18	
	21	
	24	
	27	
	30	3/4 CUT OR ROLLED
3 x 2	33	
3 x 3	36	
4 x 2	42	
4 x 3	48	
4 x 4	54	
	5 x 3	1 CUT OR ROLLED
	5 x 4	
	5 x 5	
	6 x 6	
	7 x 6	
	8 x 6	
	9 x 6	1 1/4
	10 x 6	
	108	
	120	
11 x 6 AND GREATER	138 AND GREATER	

NOTES:

- HOLES SHALL BE CAST-IN OR DRILLED 16" FROM OUTSIDE EDGE OF JOINT.
- NUTS AND WASHERS ARE NOT REQUIRED ON INSIDE OF 27" DIAMETER PIPE OR LESS.
- TIES ARE NOT REQUIRED FOR BELL PIPE 24" AND SMALLER. ON OTHER SIZES TIE MAY BE INSERTED FROM INSIDE.
- CUT THREADS MAY BE USED IF WASHER AND NUT ARE USED.
- PIPE SIZE LISTED IS INSIDE DIAMETER OF ROUND PIPE OR EQUIVALENT DIAMETER OF PIPE ARCH OR ELLIPTICAL.
- GALVANIZING OF TIES IS REQUIRED.

