

SIZE AND SPACING OF SLOTTED OPENINGS SHALL BE THE SAME AS SHOWN FOR C.M. COLLARS

BEND A 90° ANGLE 1/8" WIDE AS SHOWN IN DRAWING.

NOTE: FOR DETAILS OF FABRICATION DIMENSIONS, SLOTTED HOLES AND NOTES, SEE NOTES AND DIMENSION TABLE SHOWN BELOW.

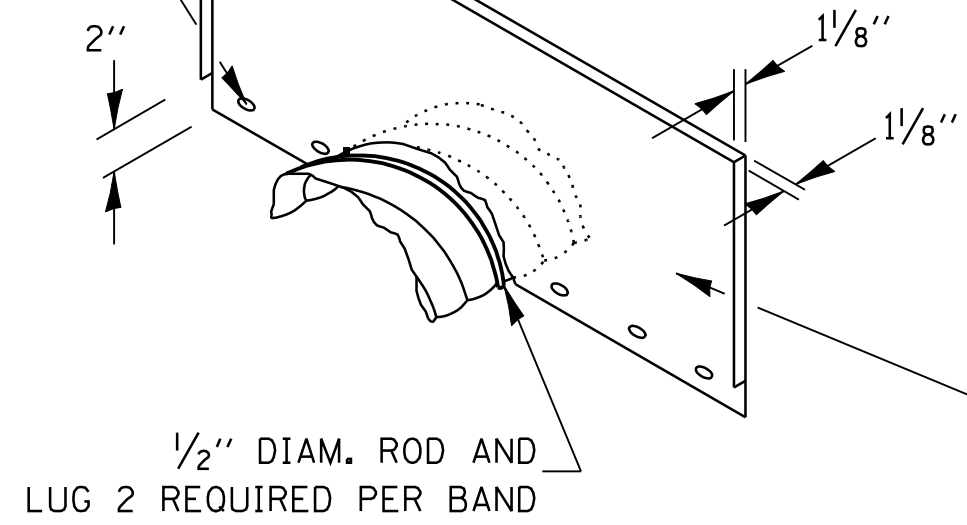

FLAT SHEET METAL COLLAR SHALL BE CUT TO FIT CORRUGATIONS OF HELICAL BAND OR CORRUGATED STEEL CULVERT AND WELDED WITH A CONTINUOUS WELD.

ISOMETRIC VIEW

USE RODS AND LUGS TO CLAMP BANDS SECURELY TO PIPE

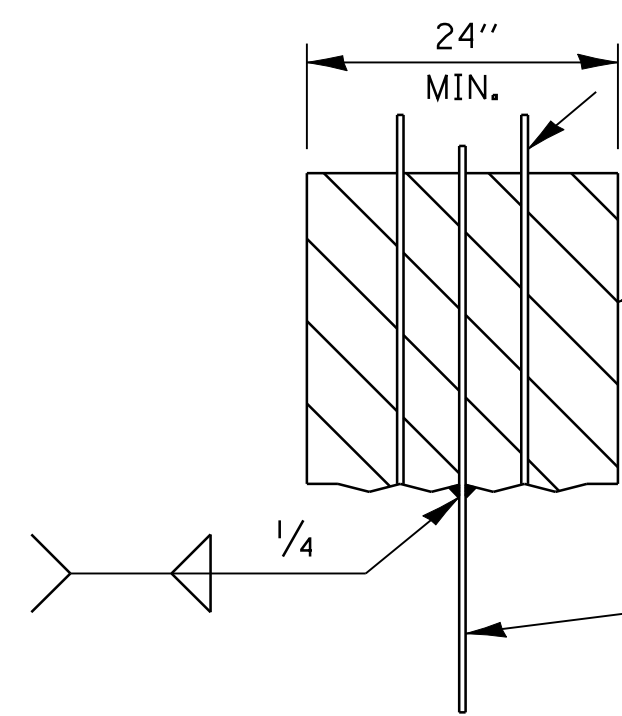

BAND OF HELICAL OR CORRUGATED PIPE

METAL COLLAR TO BE WELDED TO CENTER OF PIPE BAND

PARTIAL ELEVATION

NOTES FOR COLLARS:

1. MATERIALS AND COATING FOR ALL COLLARS SHALL BE THE SAME AS THAT SPECIFIED FOR THE PIPE.
2. COLLARS SHALL BE SHOP FABRICATED, ASSEMBLED AND MARKED BY PAINTING TO IDENTIFY MATCHING HALF SECTIONS OF EACH COLLAR.
3. THE LAPS BETWEEN THE HALF SECTIONS AND BETWEEN THE PIPE AND CONNECTING BANDS SHALL BE CAULKED WITH FIBERIZED ASPHALT MASTIC AT THE TIME OF INSTALLATION.
4. ALL TANK LUGS, RODS, AND NUTS SHALL BE GALVANIZED STEEL. WHERE ALUMINUM COLLARS ARE USED, THE RODS AND LUGS SHALL BE SEPARATED FROM THE ALUMINUM BANDS BY AT LEAST TWO (2) LAYERS OF 2" WIDE PLASTIC TAPE WITH A TOTAL THICKNESS OF 2/4 MILS OR MORE.
5. THE COLLARS SHALL BE WELDED TO THE CONNECTING BANDS AS SHOWN ON THE DRAWINGS. ALL WELDS SHALL BE TREATED AS SPECIFIED FOR CLASS I, II, AND III WELDS, MISCELLANEOUS. (REFER TO AWS STANDARD SPECIFICATIONS)
6. BANDS SHALL BE FABRICATED FROM MATERIAL HAVING THE SAME CLASS OF CORRUGATIONS AS THE PIPE TO WHICH IT IS TO BE ATTACHED.

DETAILS OF CORRUGATED PIPE COLLAR

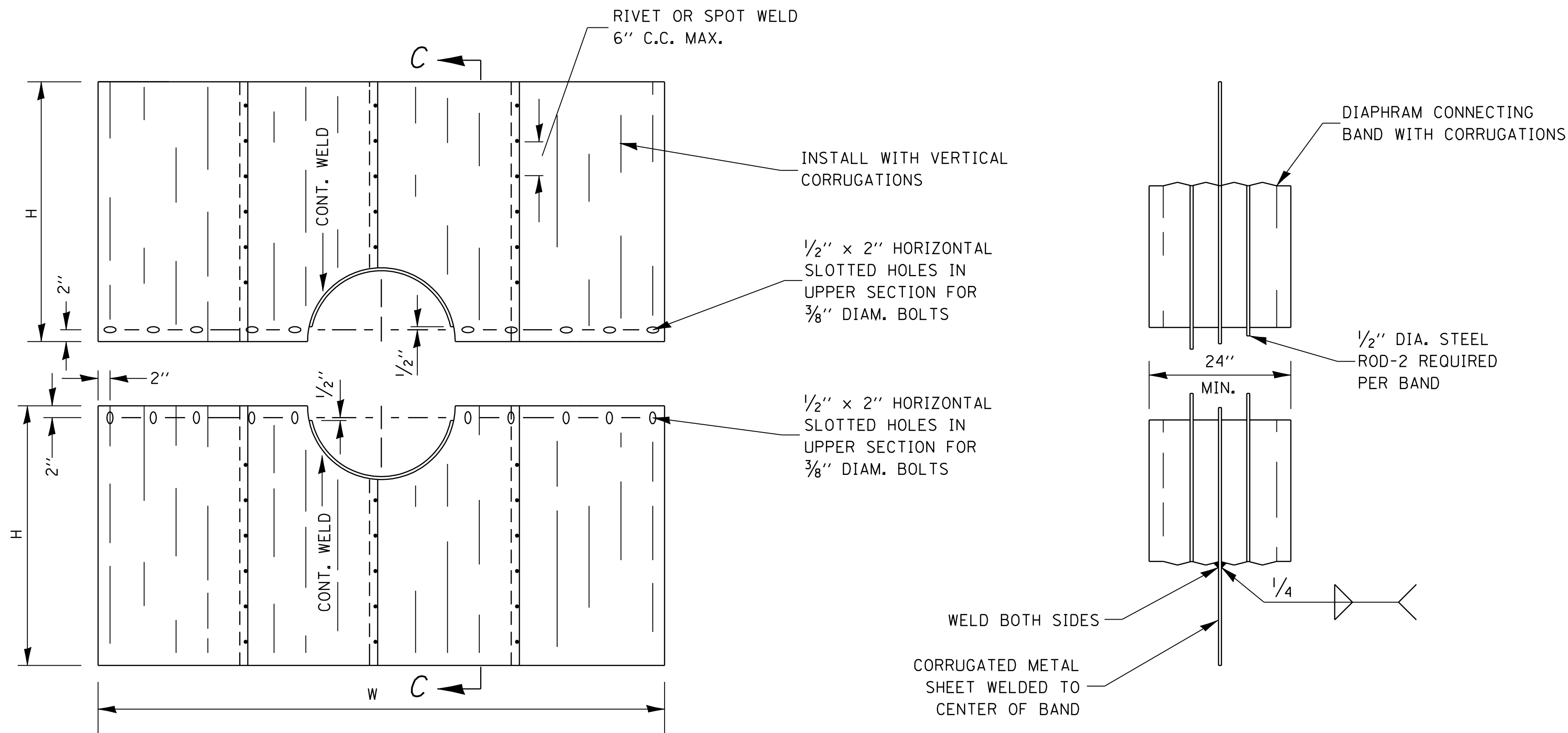

ELEVATION

SECTION C-C

SEEPAGE COLLAR DIMENSION TABLE

PIPE DIAMETER	NOMINAL COLLAR SIZE	FABRICATIONS DIMENSIONS	
		W(WIDTH)	H(HEIGHT)
15", 18", 21", 24"	8' X 6'	8' - 0"	3' - 2"
27", 30"	8' X 7'	8' - 0"	3' - 8"
36", 42", 48"	10' X 7'	10' - 0"	3' - 8"

COLLAR DIMENSIONS SHOWN MAY BE INCREASED TO ALLOW FABRICATION FROM STANDARD SIZE SHEETS.

DETAILS OF SEEPAGE COLLAR

FILE NAME =	USER NAME = corcoranlm	DESIGNED -	REVISED -
c:\pw_work\pwidot\corcoranlm\dms41560\300599.dgn		DRAWN -	REVISED -
		PLOT SCALE = 47.727' / IN.	CHECKED -
		PLOT DATE = Jul 24, 2009 - 08:34:01 AM	REVISED -

SCALE:	SHEET NO. OF SHEETS	STA. TO STA.
--------	---------------------	--------------

F.A. RTE.	SECTION	COUNTY	TOTAL SHEETS	SHEET NO.
CONTRACT NO.				
FED. ROAD DIST. NO. ILLINOIS FED. AID PROJECT				