

W.B.

BIT. SURF. W/P.C.C. BASE FULL REIN.

INTERSTATE 80, 3 MILES EAST OF FAS 268 (MARSEILLES) INTERCHANGE. LASALLE COUNTY

E.B.

DETECTOR LOOP INSTALLATION

LOOP IN P.C.C. PAVEMENT

FILL SLOT WITH 2-COMPONENT EPOXY

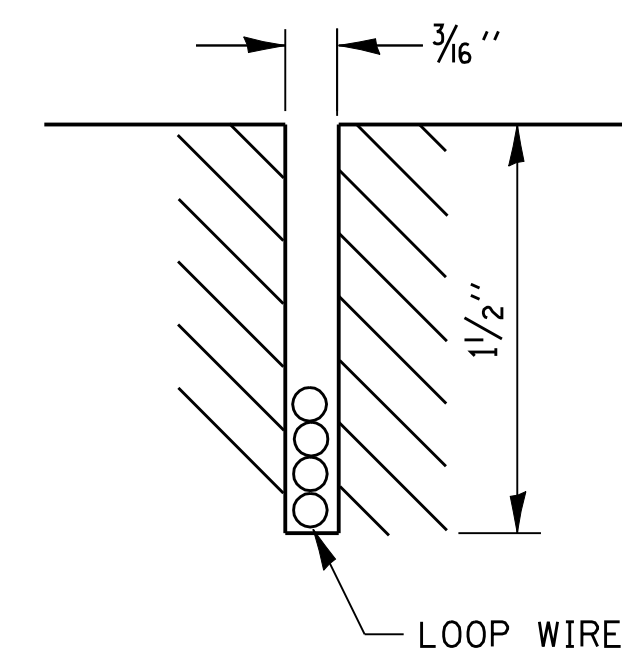

LOOP IN ASPHALT

FILL SLOT WITH 2-COMPONENT EPOXY

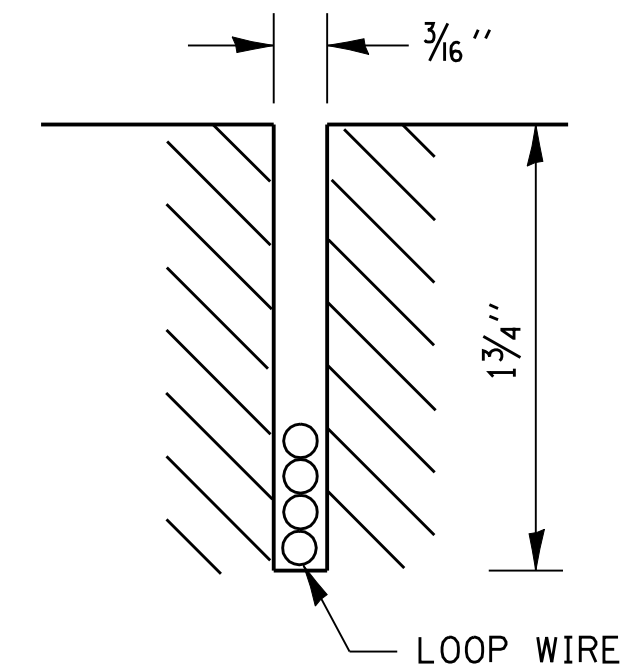

DETECTOR LOOP LEAD-IN DETAIL

DRILL HOLE IN PAVEMENT 6" - 10" FROM EDGE. INSERT CONDUIT AND FILL WITH TWO PART MASONRY EPOXY.

