

DESIGNER NOTES:
 1. Discuss with Construction and Project Engineer before using.

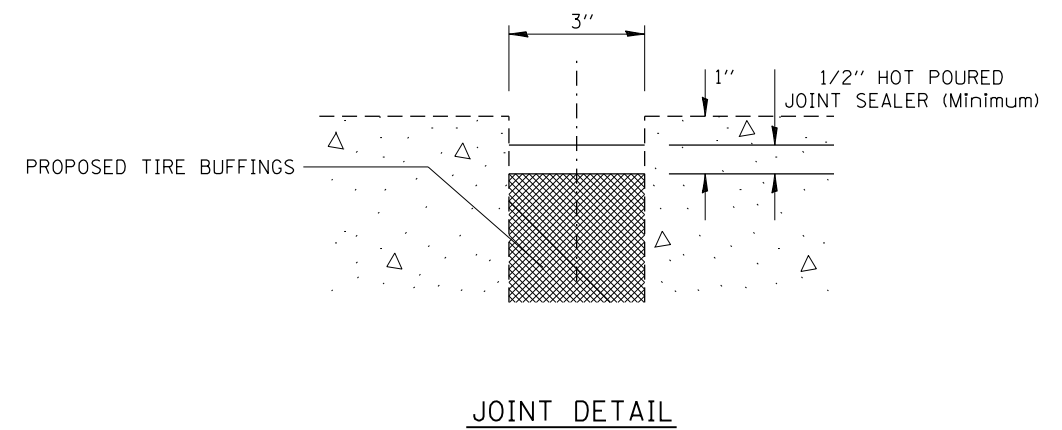
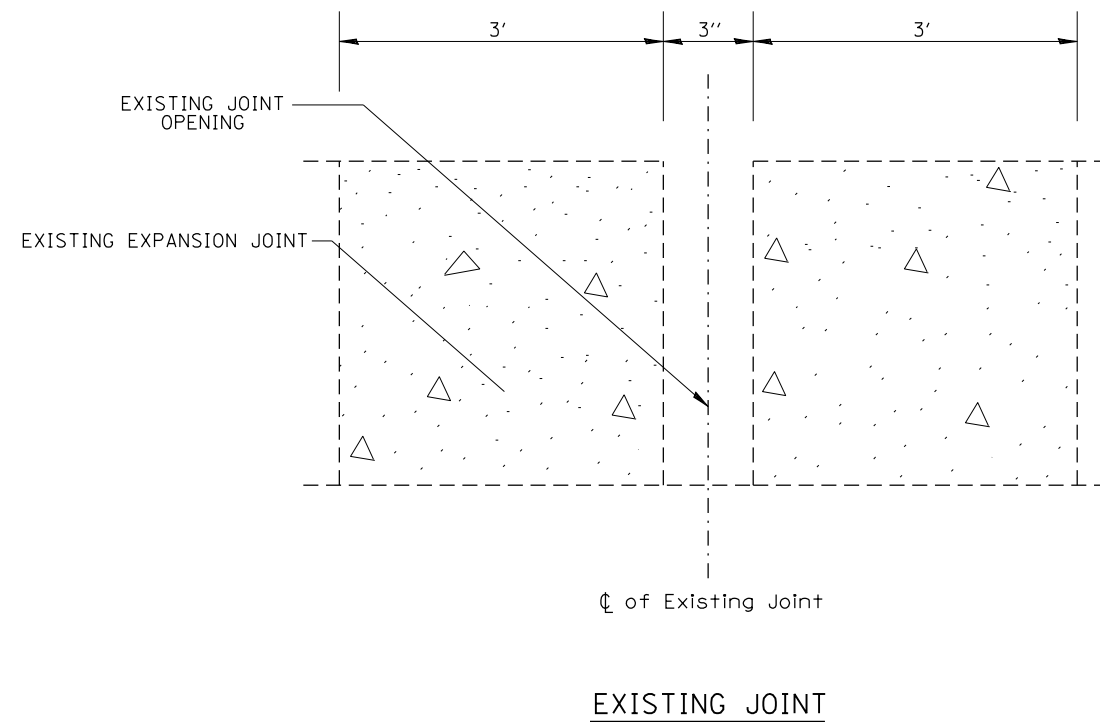

GENERAL NOTES:

1. All work shall be done as directed by the Engineer.
2. Use buffings from the tire retreading industry.
3. Ensure tire buffings are clean, dry, and without any contamination.
4. Remove existing material and replace tire buffings.
5. Place loose buffings and strike off level.
6. Compact buffings by spading with a square-nose shovel.
7. Use hot-poured joint sealer that meets the requirement of Article 1050.02 and according to the applicable section of Article 420.12 of the Standard Specifications.
8. All work and material shall be included in the unit price of EXPANSION JOINT (SPECIAL).

All dimensions are in inches (millimeters) unless otherwise noted.

09-06-12	NEW STANDARD	R.D.																		
STATE OF ILLINOIS DEPARTMENT OF TRANSPORTATION										EXPANSION JOINT (SPECIAL) DETAIL										
										NOT TO SCALE					CADD STD. 420301-D4					
										FED. ROAD DIST. NO.					ILLINOIS FED. AID PROJECT					
										CONTRACT NO.										