

DESIGNER NOTES:
 1. Include District Special Provision.
 2. This is a special use item. Check with your Project Engineer before using (Problematic Design).
 3. Based upon a "Raider Precast Concrete, Inc." Design

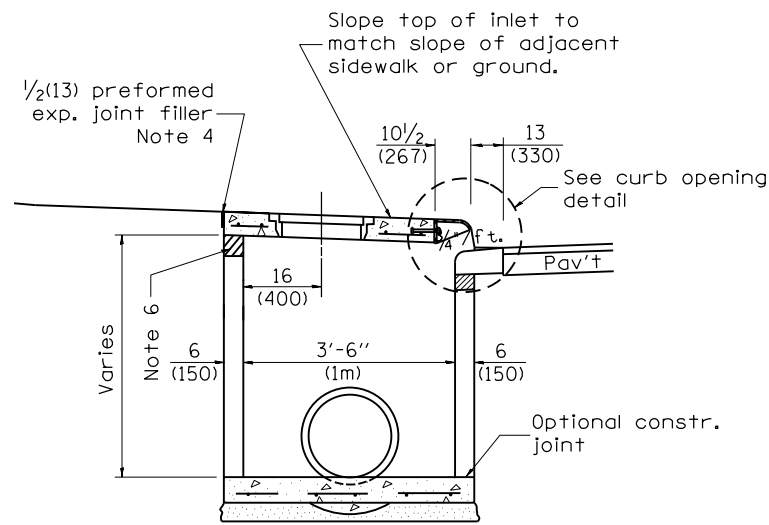

SECTION A-A

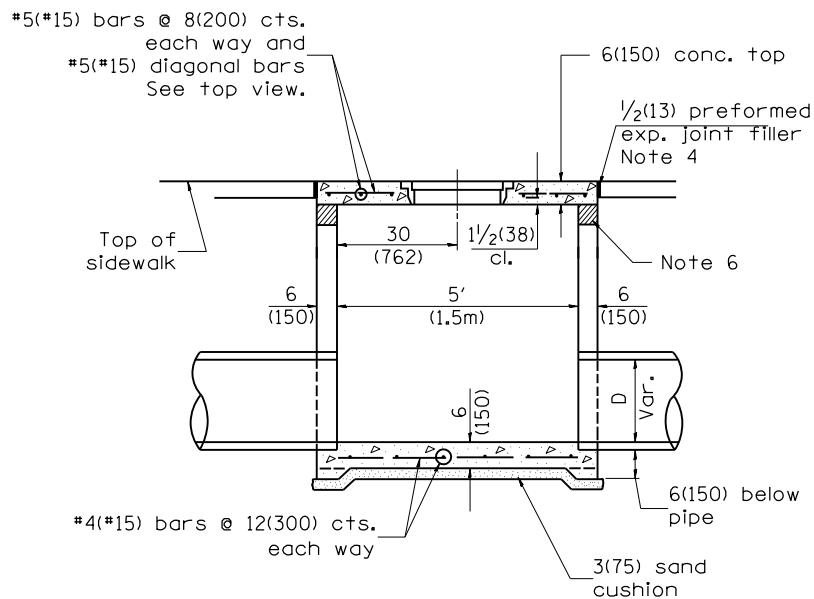

SECTION B-B

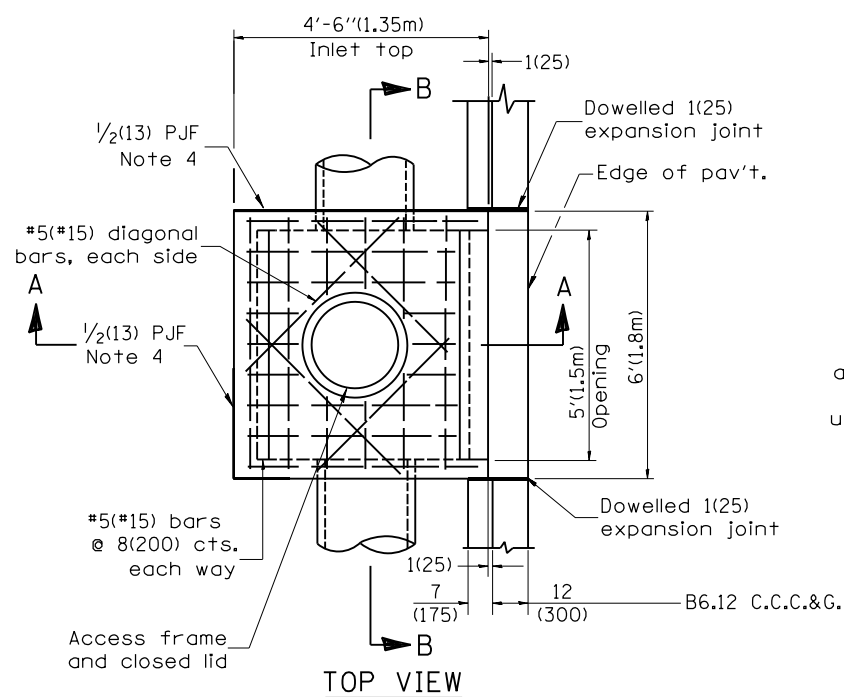

INLET SPECIAL TYPE 1

[Front Opening
4'-6" (1.35 Top)]

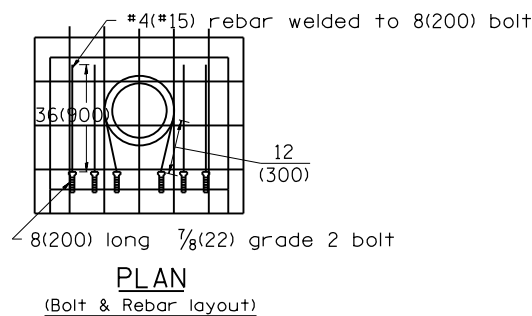

PLAN

(Bolt & Rebar layout)

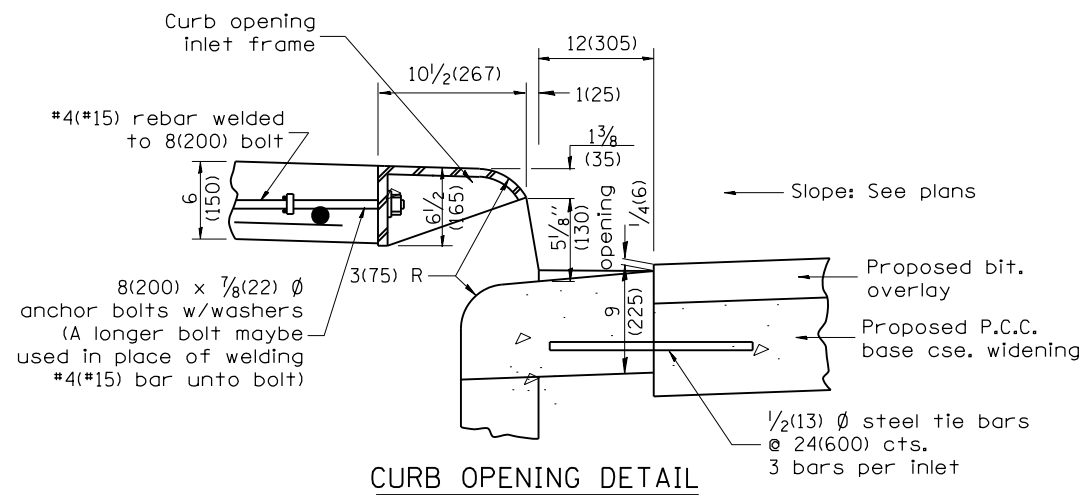

CURB OPENING DETAIL

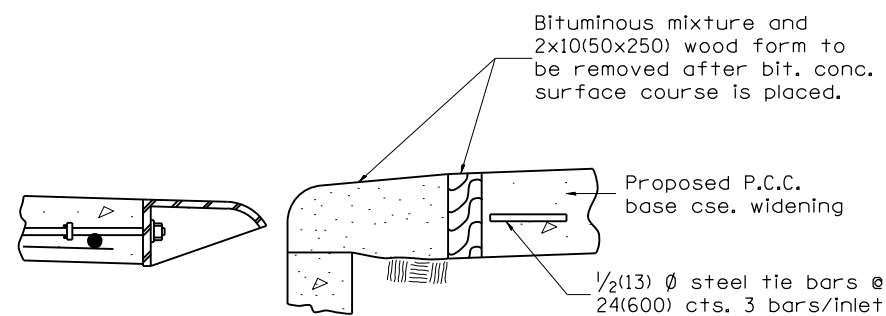

CURB OPENING DETAIL
FOR TEMPORARY PAVEMENT DRAINAGE

GENERAL NOTES

- Class PC concrete for precast concrete and CLASS SI CONCRETE for cast-in-place concrete used throughout.
- The sidewalls may be built as precast segmental sections.
- Except as noted herein, INLET SPECIAL TYPE 1, TYPE 2, AND, TYPE 3 shall be constructed in accordance with section 602 of the Standard Specifications.
- 1/2(13) preformed expansion joints shall be provided on sides of inlet adjacent to sidewalks or other structures. (See section 1051)
- Curb opening inlet frame, and access frame and lid shall be cast gray iron and conform to A48-83 class 35B
 Approximate weight:
 Curb opening inlet frame: 100lbs/30(45kg/750)
 section Access frame and lid: 160 lbs(73kg)/ casting.
- The height of the box may be constructed 6(150) short to allow for field adjustment. The wall adjustments shall be made with concrete building brick or CLASS SI CONCRETE. (See article 1041.02 and applicable portions of section 503).

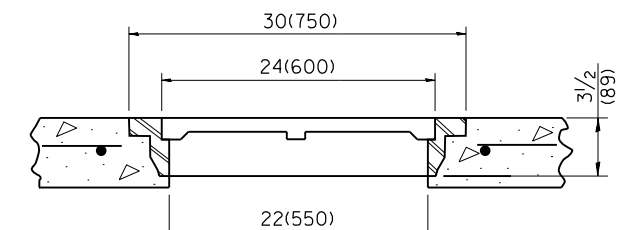

ACCESS FRAME & LID
DETAIL

01-01-97	RENUM. B-4.12, NEW REVISION BOX, ADDED DESIGNER				
	NOTES, NEW FORMAT				
10-16-06	REVISED TO 2007 SPEC.	M.A.			

STATE OF ILLINOIS
DEPARTMENT OF TRANSPORTATION

NOT TO SCALE

INLET SPECIAL TYPES 1, 2 & 3

SHT. 1 OF 2
CADD STD. 602201-D4

All dimensions are in inches (millimeters) unless otherwise noted.

F.A. RTE.	SECTION	COUNTY	TOTAL SHEETS	SHEET NO.
CONTRACT NO.				
FED. ROAD DIST. NO. ILLINOIS FED. AID PROJECT				

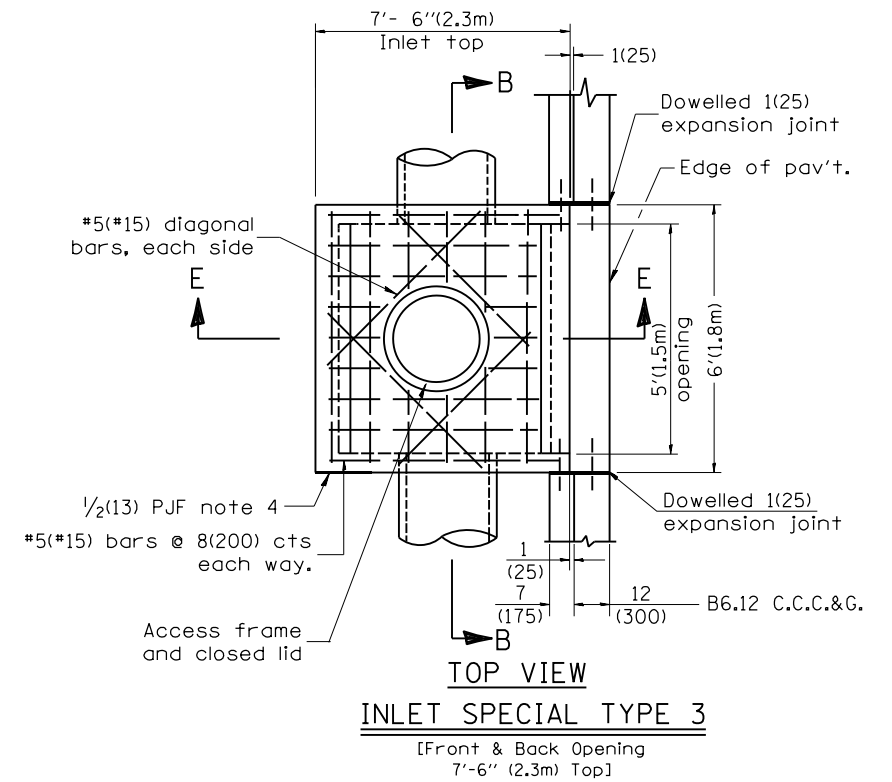
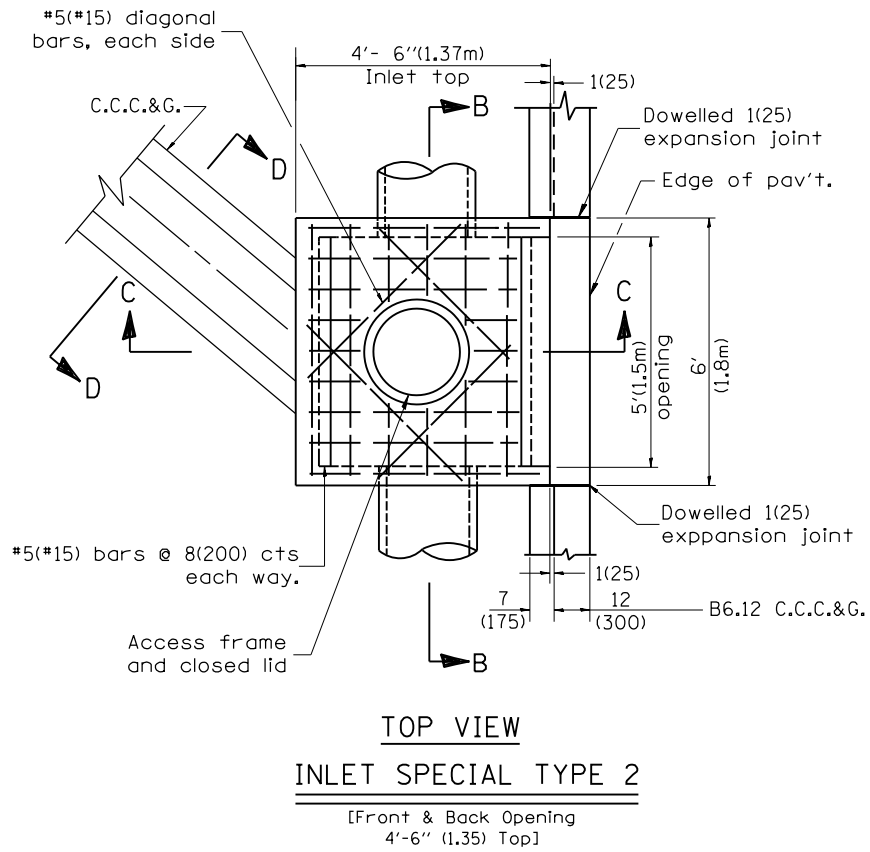
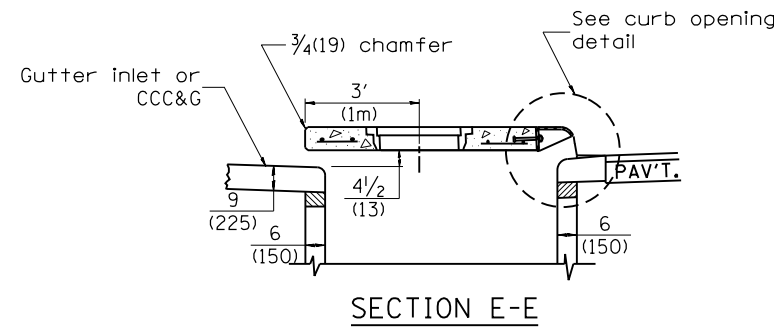
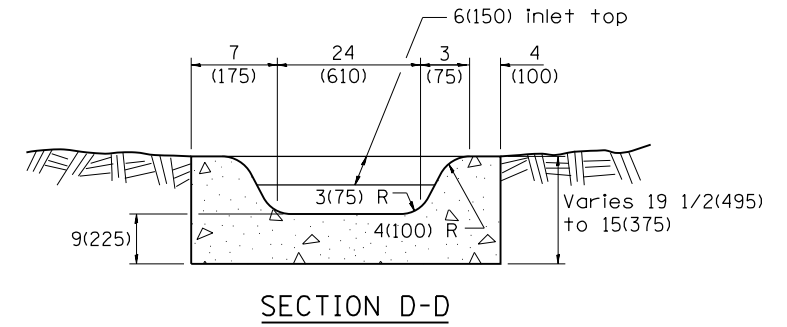
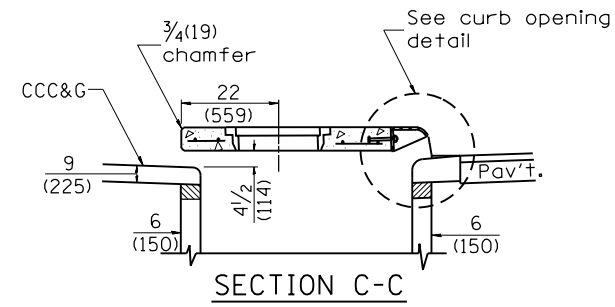

All dimensions are in inches (millimeters) unless otherwise noted.

STATE OF ILLINOIS
DEPARTMENT OF TRANSPORTATION

INLET SPECIAL TYPES 1, 2 & 3

NOT TO SCALE

SHT. 2 OF 2
CADD STD. 602201-D4

F.A. RTE.	SECTION	COUNTY	TOTAL SHEETS	SHEET NO.
CONTRACT NO.				
FED. ROAD DIST. NO. ILLINOIS FED. AID PROJECT				