

DESIGNER NOTE: THIS DISTRICT 5 DETAIL SHOULD BE USED WITH RECURRING SPECIAL PROVISION CHECK SHEET #15 AND SHALL ALSO APPLY TO PREVIOUSLY RESURFACED PCC PAVEMENT.

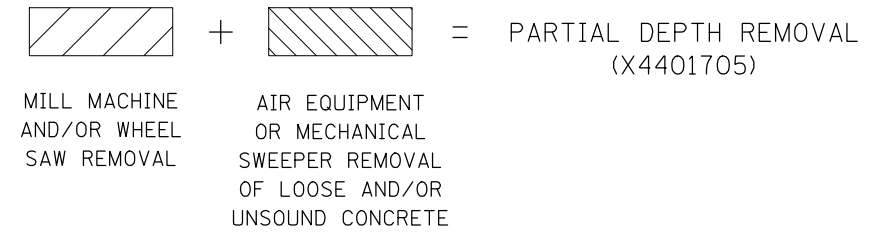
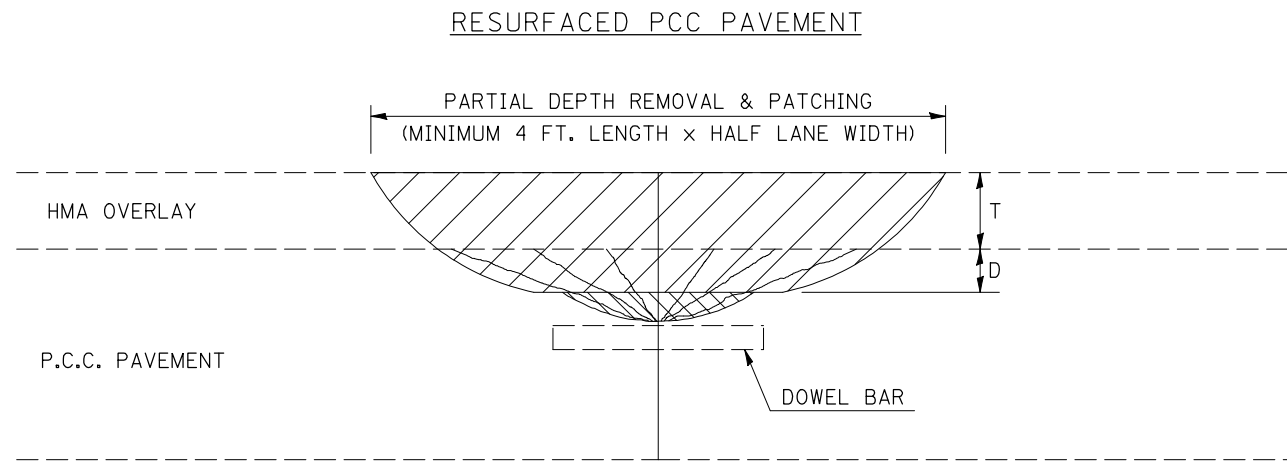

DESIGN NOTES

PARTIAL DEPTH HMA PATCHING SHALL NOT BE USED WHEN HMA OVERLAY THICKNESS (T) ON PCC PAVEMENT EXCEEDS 4 3/4 INCHES (145 mm) OR ON CRC PAVEMENT.

GENERAL NOTES

ALL VOLUME OF PARTIAL DEPTH REMOVAL SHALL BE REPLACED WITH HOT-MIX ASPHALT (HMA) AND PAID FOR AT THE CONTRACT UNIT PRICE PER TON FOR PARTIAL DEPTH PATCHING.

T = THICKNESS OF HMA OVERLAY(S). SEE EXISTING TYPICAL CROSS SECTION.

GENERAL NOTE 406H SHALL INCLUDE MIXTURE REQUIREMENTS FOR PARTIAL DEPTH PATCHING.

HMA REPLACEMENT IN RESURFACED PCC PAVEMENT LOCATIONS SHALL BE ACCORDING TO SECTION 406 OF THE STANDARD SPECIFICATIONS.

D = DEPTH OF PARTIAL DEPTH REMOVAL INTO EXISTING PCC PAVEMENT. (3" (75 mm) ± OR TO SOUND CONCRETE)

TRANSVERSE CONTRACTION JOINT SHOWN - OTHER LOCATIONS SIMILAR.

Note: All dimensions are in INCHES (millimeters) unless otherwise shown.

BARE PCC PAVEMENT

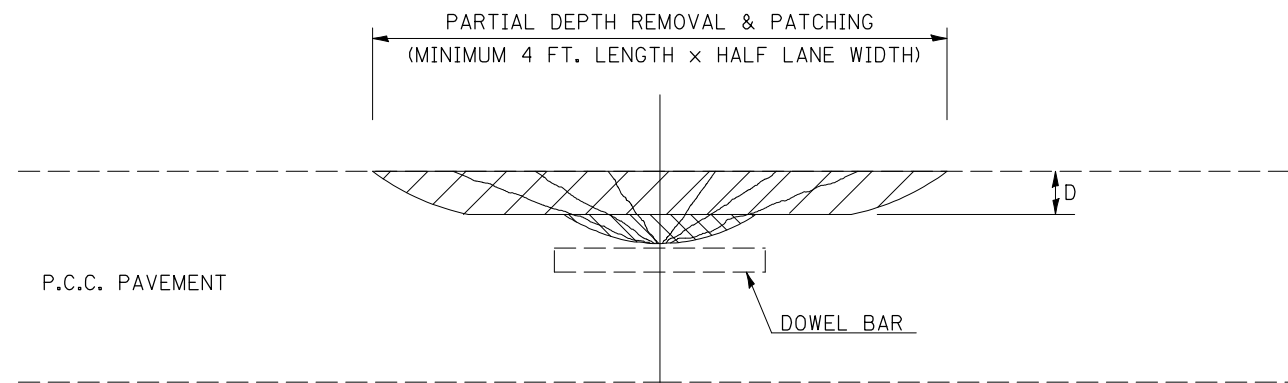

DISTRICT 5 DETAIL NO. XX442100

FILE NAME =	USER NAME = craigre	DESIGNED -	REVISED - 11/06
ct:\pw\work\PWIDOT\CRAIGRE\d0101509\xx442100.dgn		DRAWN -	REVISED -
	PLOT SCALE = 40.000' / IN.	CHECKED -	REVISED -
	PLOT DATE = 1/7/2010	DATE -	REVISED -

**STATE OF ILLINOIS
DEPARTMENT OF TRANSPORTATION**

PCC PARTIAL DEPTH HOT-MIX ASPHALT PATCHING

SCALE: SHEET NO. OF SHEETS STA. TO STA.

F.A. RTE.	SECTION	COUNTY	TOTAL SHEETS	SHEET NO.
CONTRACT NO.				
FED. ROAD DIST. NO. ILLINOIS FED. AID PROJECT				