



Original Report Date: 6/13/2023 Proposed SN: 053-0194 Route: FAP 673 (IL 116)
 Revised Date: 3/9/2024 Existing SN: 053-0062 Section: (112BR)ES
 Geotechnical Engineer: Jeremy Brown, P.E. (IDOT D3) County: Livingston
 Structural Engineer: _____ Contract: 66L79

Indicate the proposed structure type, substructure types, and foundation locations (attach plan and elevation drawing): The proposed structure will be a 3-span slab bridge on integral abutments with a back-to-back length of 88'-9", and have an out-to-out width of 36'. The structure will have a 20 degree left ahead skew. Load information provided by the Bureau of Bridges and Structures indicates factored loads of 802.6 kips at the abutments and 1016.4 kips at the two piers. Staged construction will be utilized for construction of the new bridge. An approved copy of the TS&L is attached.

Discuss the existing boring data, existing plans foundation information, new subsurface exploration and need for any additional exploration to be provided with SGR Technical Memo (attach all data and subsurface profile plot): Soil borings from 1965 are available and include a boring at each abutment and the existing center pier. Soil borings were conducted at the abutments in 2020 by IDOT. The 1965 soil borings were used to extend the 2022 borings since they were not drilled deep enough to accommodate driven pile foundations. Soil boring log 2 from 1965 was used to extend the depth of boring log 1 from 2022. Soil boring log 3 from 1965 is labeled "Center Pier", however the station/offset places it close to the proposed east abutment which is why it was used to extend the depth of soil boring 2 from 2022. The existing structure is a two-span concrete slab bridge with cantilever-type closed abutments with spread footings and has a solid battered stem pier supported on a spread footing. Copies of the boring logs are attached.

Provide the location and maximum height of any new soil fill or magnitude of footing bearing pressure. Estimate the amount and time of the expected settlement. Indicate if further testing, analysis, and/or ground improvement/treatment is necessary: Based on the approved TS&L, cuts and fills are proposed to be minimal for the approach pavement areas. Settlement of the approach pavement is little concern due to the minimal fills proposed. A site visit showed no signs of settlement. No further settlement analysis is warranted.

Identify any new cuts or fill slope angles and heights. Estimate the factor of safety against slope failure. Indicate if further testing, analysis or ground improvement/treatment is necessary: Minimal grade change is expected. The end slope on the creek side of the abutment will be a 1:2(V:H) slope with a slope height near 8 feet to the bottom of the proposed abutment. The short term FOS is estimated to be 2.363 and the long term FOS is 1.847. These factors of safety were estimated using the Slide 2 software using Boring 1 for the south abutment. No further analysis is warranted.

Indicate at each substructure, the 100-year and 200-year total scour depths in the Hydraulics report, the non-granular scour depth reduction, the proposed ground surface, and the recommended foundation design scour elevations: No scour was accounted for at the abutments per IDOT policy. The design scour elevations and bottom of abutment elevations are 651.23 and 651.07 for the west abutment and east abutment respectively. Per the Hydraulic Report, the total pier scour depths for Q100 and Q200 are 6.08 ft and 6.12 ft respectively. The following scour depths were calculated using the IDOT Scour Analysis spreadsheet. Copies of the spreadsheets are attached.

Event/Limit State	Design Scour Elevations (ft.)				Item 113
	W. Abut	Pier 1	Pier 2	E. Abut.	
Q100	651.23	638.40	638.40	651.07	8
Q200	651.23	638.30	638.30	651.07	
Design	651.23	638.40	638.40	651.07	
Check	651.23	638.30	638.30	651.07	

Determining the seismic soil site class, the seismic performance zone, the 0.2 and 1.0 second design spectral accelerations and indicate if that the soils are liquefiable: Seismic Soil Site Class = C. The SDS = 0.133g. The SD1 = 0.078g. The Seismic Performance Zone (SPZ) for this bridge = 1, therefore a liquefaction analysis was not performed.

Confirm feasibility of the proposed foundation or wall type and provide design parameters. Attach a pile design table indicating feasible pile types, various nominal required bearings, factored resistances available and corresponding estimated lengths at locations where piles will be used. Provide factored bearing resistance and unit sliding resistance at various elevations and confirm no ground improvement/treatment is necessary where spread footings are proposed. Estimated top of rock elevations as well as preliminary factored unit side and tip resistance values shall be indicated when drilled shafts are proposed: Soil borings 1 (SW Quad) and 2 (NE Quad) from 2022 and soil borings 2 (West Abut.) and 3 (Center Pier) from 1965 were used to design the foundations for the proposed structure. Integral abutments are feasible for the proposed structure. The abutments and piers should utilize conventional construction methods to drive piles until the desired nominal required bearing is achieved. Metal shell piles with a wall thickness of at least 0.312 inches and pile shoes are recommended for both abutments and piers due to the hard till layers encountered. Bedrock was not encountered in the soil boring logs, therefore H-piles are not recommended since they will drive significantly longer than metal shell piles. One test pile at each foundation element is recommended for a total of four test piles. The integral abutment feasibility analysis, pile design tables, and lateral loading soil parameters are attached.

Calculate the estimated water surface elevation and determine the need for cofferdams (type 1 or 2), and seal coat: From the hydraulic report, the estimated water surface elevation is 645.26. There will be two solid wall piers that will require in stream work. Because the EWSE of 645.26 is less than 6 ft. above the base of the concrete of the piers, type I cofferdams are recommended. From the data shown in the soil boring logs, it should not be an issue driving the sheet piling to the design depth at this location.

Assess the need for sheeting or soil retention or temporary construction slope and provide recommendation for other construction concerns: Temporary sheet piling will be necessary for staged construction. The soils within the embedment depth do not exceed 4.5 tsf, therefore temporary sheet piling is feasible and the pay item TEMPORARY SHEET PILING should be used.

Benchmark: Cut "□" on top of S.W. Wingwall, Station 569+25.51, 24.86' Rt., Elev. = 657.302.

Existing Structure (No. 053-0062):

Was originally constructed in 1970 under F.A. Route 147, Section 112-BR at Sta. 569+68. The superstructure consists of a 2-span continuous 16" slab, all supported on solid battered stem pier and cantilever-type closed abutments supported on spread footings. The structure has a 24°15'00" left ahead skew, a 46'-6" out-to-out width and an overall length of 63'-5 3/8" back-to-back. In 2002, the bridge was rehabilitated.

Traffic to be maintained using staged construction.

No Salvage.

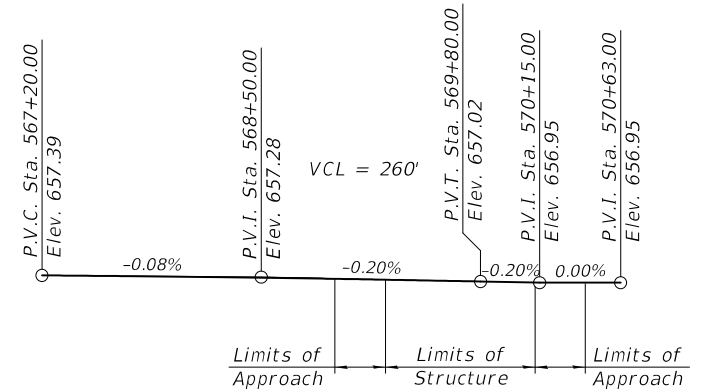
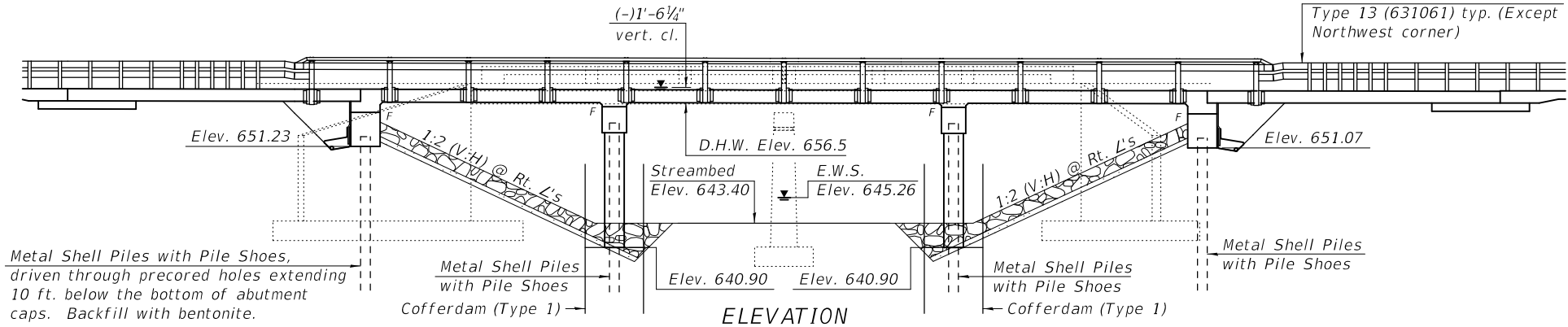

PROFILE GRADE - IL. RTE. 116
(Along C of Roadway)

DESIGN SPECIFICATIONS
2020 AASHTO LRFD Bridge Design Specifications, 9th Edition

LOADING HL-93

Allow 50#/sq. ft. for future wearing surface.

DESIGN STRESSES

FIELD UNITS

$f'_c = 3,500$ psi
 $f'_c = 4,000$ psi (Superstructure)
 $f_y = 60,000$ psi (Reinforcement)

SEISMIC DATA

Seismic Performance Zone (SPZ) = 1
Design Spectral Acceleration at 1.0 sec. (SD1) = 0.078g
Design Spectral Acceleration at 0.2 sec. (SDS) = 0.133g
Soil Site Class = C

HIGHWAY CLASSIFICATION

F.A.P. Rte. 673 - IL Rte 116
Functional Class: Minor Arterial
ADT: 2809 (2025); 3339 (2045)
ADTT: 253 (2025); 301 (2045)
DHV: 301 (2045)
Design Speed: 55 m.p.h.
Posted Speed: 55 m.p.h.
Two-Way Traffic
Directional Distribution: 50:50

APPROVED

OCTOBER 31, 2023

AS A BASIS FOR
PREPARATION OF DETAILED PLANS

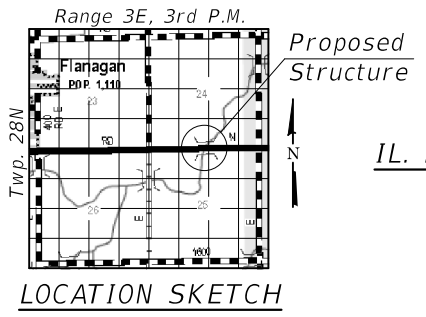
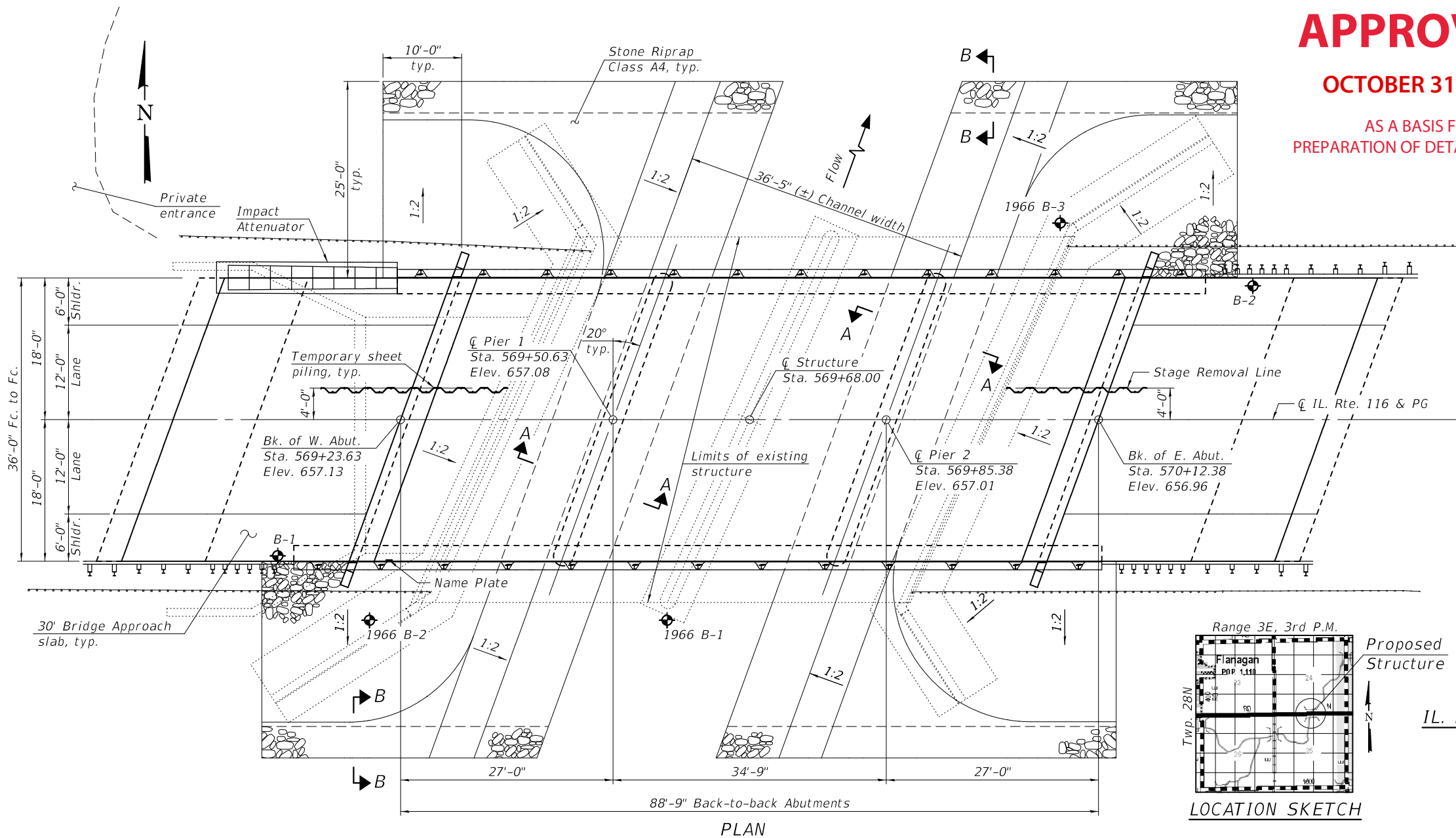

GENERAL PLAN & ELEVATION
IL. ROUTE 116 OVER OVER SCATTERING POINT CREEK
F.A.P. ROUTE 673 - SECTION (112BR)ES
LIVINGSTON COUNTY
STATION 569+68.00
STRUCTURE NO. 053-0194

MODEL: 0530062-66L79-TSL-001
FILE NAME: pw:\idot-pw\benley.com\FWIDOT\Documents\Bureau of Bridges and Structures\Projects\0530194\CADD Plans\0530194-66L79.dgn

DESIGNED -	NEPHTALI RIVERA-MARTINEZ
CHECKED -	MICHAEL A. PAULIONIS
DRAWN -	DENNIS A. POP
CHECKED -	N.R.M. / M.A.P. / J.O.V.

10/31/2023 10:20:11 AM

STATE OF ILLINOIS
DEPARTMENT OF TRANSPORTATION

SHEET 1 OF 2 SHEETS

F.A.P. RTE.	SECTION	COUNTY	TOTAL SHEETS	SHEET NO.
673	(112BR) ES	LIVINGSTON	1	2
CONTRACT NO. 66L79				

ILLINOIS FED. AID PROJECT

*Subject to refinement during final design.

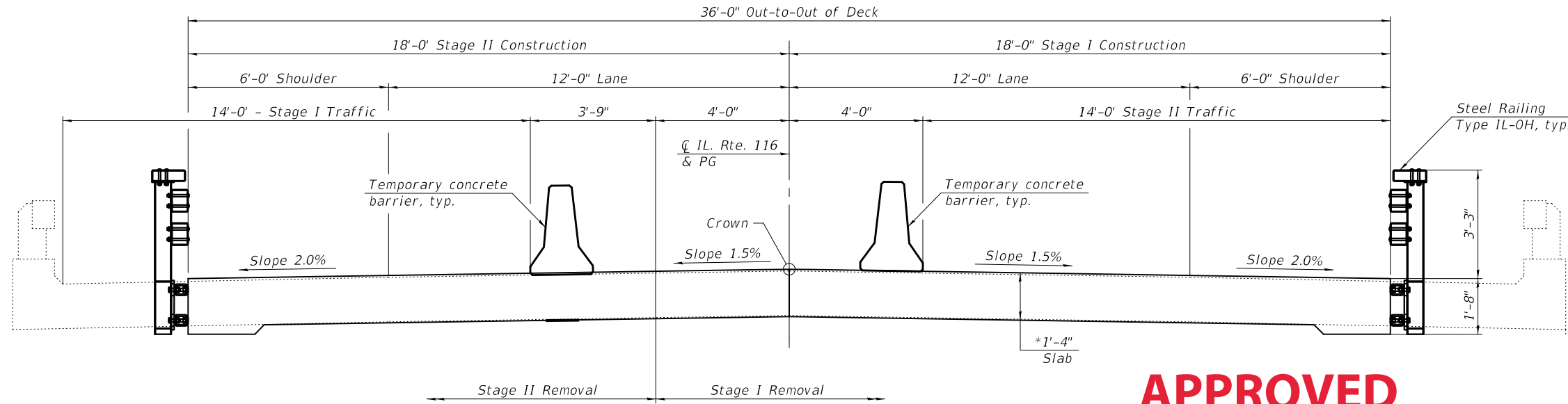

APPROVED

OCTOBER 31, 2023

AS A BASIS FOR
PREPARATION OF DETAILED PLANS

CROSS SECTION
(Looking East)

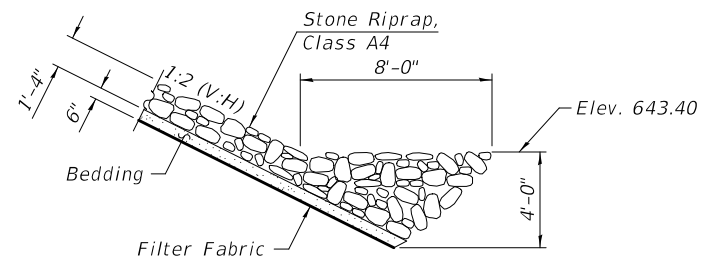

SECTION A-A

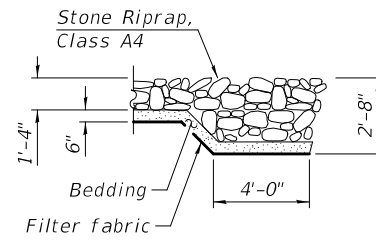

SECTION B-B

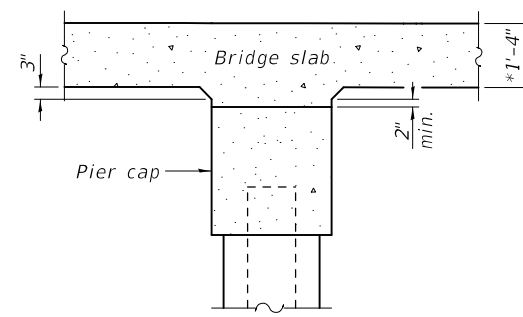

SECTION THRU PIER

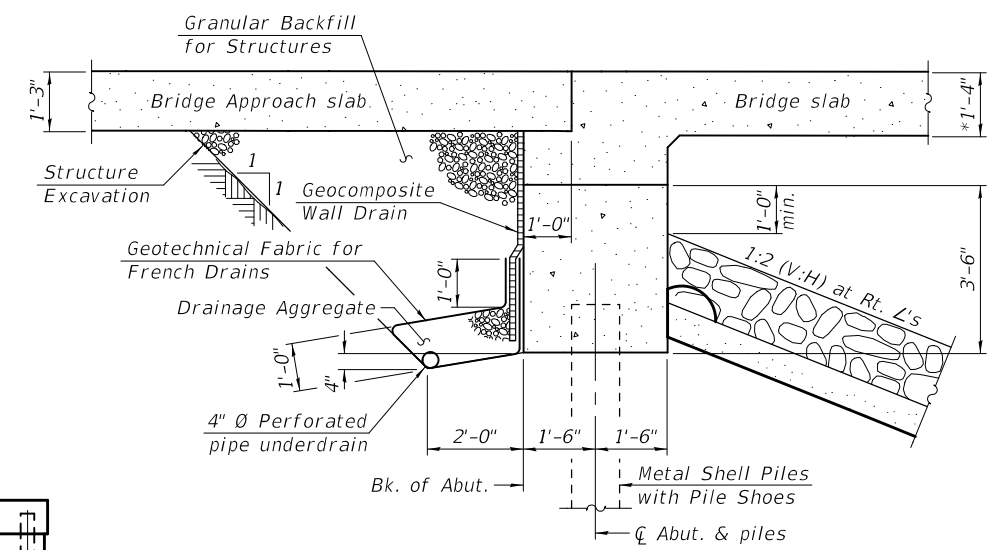

SECTION THRU ABUTMENT
(Horiz. dim. @ Rt. L's)

DESIGN SCOUR ELEVATION TABLE

Event / Limit State	Design Scour Elevations (ft.)				Item 113
	W. Abut.	Pier 1	Pier 2	E. Abut.	
Q100	651.23	638.40	638.40	651.07	8
Q200	651.23	638.30	638.30	651.07	
Design	651.23	638.40	638.40	651.07	
Check	651.23	638.30	638.30	651.07	

WATERWAY INFORMATION TABLE

Flood Event	Freq. Yr.	Q C.F.S.	Opening Ft ²		Nat. H.W.E.	Head - Ft.		Headwater El.	
			Exist.	Prop.		Exist.	Prop.	Exist.	Prop.
Drainage Area = 20.5 Existing Overtopping Elev. 656.88 @ Sta. 570+20 Proposed Overtopping Elev. 656.92 @ Sta. 574+70									
Ten-Year	10	2,460	554	649	655.2	0.8	0.6	656.0	655.8
Overtop Existing	28	3,440	554	-	656.1	1.8	-	657.9	-
Overtop Proposed	36	3,690	-	649	656.3	-	1.2	-	657.5
Design	50	3,970	554	649	656.5	1.9	1.4	658.3	657.9
Base	100	4,650	554	649	656.9	1.9	1.5	658.9	658.4
Scour Check	200	5,360	554	649	657.4	2.0	1.2	659.4	658.6
Max. Calc.	500	6,300	554	649	658.0	1.2	0.9	659.2	658.9

10 year velocity through existing bridge = 4.7 ft/s
10 year velocity through proposed bridge = 3.8 ft/s

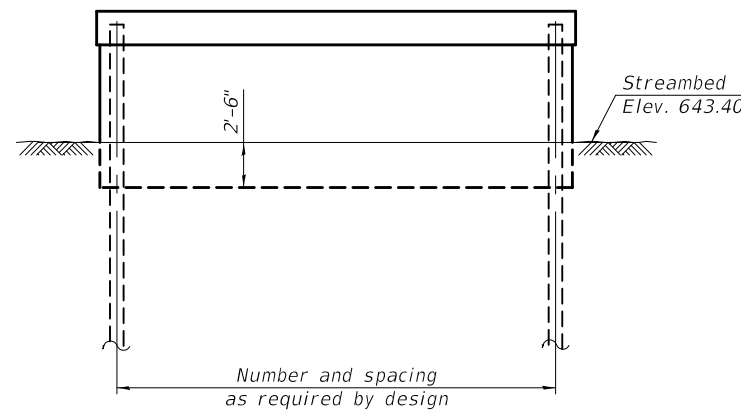

PIER SKETCH

DETAILS
IL. ROUTE 116 OVER OVER SCATTERING POINT CREEK
F.A.P. ROUTE 673 - SECTION (112BR)ES
LIVINGSTON COUNTY
STATION 569+68.00
STRUCTURE NO. 053-0194

STATE OF ILLINOIS
DEPARTMENT OF TRANSPORTATION

SHEET 2 OF 2 SHEETS

F.A.P. RTE.	SECTION	COUNTY	TOTAL SHEETS	SHEET NO.
673	(112BR) ES	LIVINGSTON	2	2
CONTRACT NO. 66L79				

MODEL: 0530062-66L79-TSL-002
FILE NAME: pw:\idot-pw\benley.com\FWIDOT\Documents\DOT Offices\Bureau of Bridges and Structures\Projects\0530194\CADD Plans\0530194-66L79.dgn

10/31/2023 10:19:33 AM

ILLINOIS FED. AID PROJECT



SOIL BORING LOG

ROUTE FAP 673 (IL 116) DESCRIPTION IL 116 over Scattering Point Creek, 0.5 mi W of N 600 E Rd LOGGED BY Larry Myers

SECTION (112BR)ES LOCATION NE 1/4, SEC. 25, TWP. 28, RNG. 3E, 3rd PM,
 Latitude 40.87163, Longitude -88.82465

COUNTY Livingston DRILLING METHOD Hollow Stem Auger HAMMER TYPE CME Automatic

STRUCT. NO.	STATION	DEPTH (ft)	BLOW (ft/6")	UCS (tsf)	MOIST (%)	Surface Water Elev. (ft)	Stream Bed Elev. (ft)	GROUNDWATER ELEV. (ft)	FIRST ENCOUNTER Upon Completion After (ft)	DEPTH (ft)	BLOW (ft/6")	UCS (tsf)	MOIST (%)
053-0062 (Exist.)	569+68												
1 (SW Quad)	569+08												
	Offset 17.3 ft Rt.												
	Ground Surface Elev. 656.55												
Augered Shoulder Stone and Black Silty Clay Loam Fill										4			
	654.05								634.55	3	2.0	18	
Stiff Black Silty Clay Loam Fill with Organics			3		26					5	P		
			3	1.5						7			
			3	P						13	3.0	18	
			3							20	P		
			2							-25			
			2	1.3	36					9			
			2	P						11	2.5	22	
			2							13	P		
			3							629.05			
			2	1.5	29					7			
			2	P						11	4.2	14	
			2							13	S		
	646.55 -10		WH							-30			
Loose Sand			1		47					8			
WH = Weight of Hammer			20							14	4.4	14	
Concrete (Soft) @ 11'			20							19	S		
	644.05		8										
Very Stiff Gray Silty Clay Loam Till with Sand Layers, Silt Pockets			8	2.0	15								
			10	P									
			5							-35			
			7	3.5	14					9			
			8	S						13	4.2	14	
			8							18	S		
			3						620.05				
			4	2.5	14								
			5	P									
	636.55 -20									-40			

SOIL BORING 053-0062.GPJ IL_DOT.GDT 7/27/22

Extended with Boring No. 2 (1965)

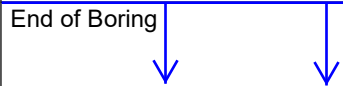

The Unconfined Compressive Strength (UCS) Failure Mode is indicated by (B-Bulge, S-Shear, P-Penetrometer)
 The SPT (N value) is the sum of the last two blow values in each sampling zone (AASHTO T206)



SOIL BORING LOG

IL 116 over Scattering Point Creek, 0.5 mi W of N
 600 E Rd

ROUTE FAP 673 (IL 116) DESCRIPTION IL 116 over Scattering Point Creek, 0.5 mi W of N 600 E Rd LOGGED BY Larry Myers

SECTION (112BR)ES LOCATION SE 1/4, SEC. 24, TWP. 28, RNG. 3E, 3rd PM, Latitude 40.87173, Longitude -88.8242

COUNTY Livingston DRILLING METHOD Hollow Stem Auger HAMMER TYPE CME Automatic

STRUCT. NO. 053-0062 (Exist.)
 Station 569+68

BORING NO. 2 (NE Quad)
 Station 570+32
 Offset 17.0 ft Lt.
 Ground Surface Elev. 656.57 ft

**D
E
P
T
H** (ft)
**B
L
O
W
S** (/6")
**U
C
S** (tsf)
**M
O
I
S
T** (%)

Surface Water Elev. _____ ft
 Stream Bed Elev. _____ ft
 Groundwater Elev.:
 First Encounter 644.1 ft
 Upon Completion 644.1 ft
 After _____ Hrs. _____ ft

**D
E
P
T
H** (ft)
**B
L
O
W
S** (/6")
**U
C
S** (tsf)
**M
O
I
S
T** (%)

Augered Shoulder Stone, Black Silty Clay Loam Fill				
	654.07			
Stiff Black Silty Clay Loam Fill	2			
	2	1.5	30	
	2	P		
	-5			
Stiff Gray and Brown Silty Clay Loess	2			
	2	1.8	28	
	3	P		
	649.57			
WH = Weight of Hammer				
	2	1.5	24	
	2	P		
	-10			
Stiff Brown Silty Clay Loam				
	1			
	645.07			
Very Stiff Gray Silty Clay Loam Till with Sandy Silt Layers				
	1	1.0	21	
	643.07			
Very Stiff Gray Silty Clay Loam Till with Sandy Silt Layers	4			
	4	3.7	19	
	10	B		
	-15			
End of Boring	1			
	4	2.2	21	
	5	B		
	-20			

Very Stiff Gray Silty Clay Loam Till with Sandy Silt Layers (<i>continued</i>)	4			
	5	2.6	14	
	6	B		
	634.57			
Very Stiff Gray Silt with some Fine Sand Layers	10			
	13	2.5	21	
	18	P		
	-25			
Hard Olive Gray Silty Loam Till	6			
	8	2.0	16	
	10	P		
	629.07			
Hard Olive Gray Silty Loam Till	3			
	8	4.2	14	
	12	S		
	-30			
End of Boring	8			
	12	4.6	13	
	645.07			
End of Boring	12	4.6	13	
	14	S		
	-35			
End of Boring	9			
	12	4.4	16	
	19	S		
	620.07			
End of Boring	12	4.4	16	
	19	S		
	-40			

Extended with Boring No. 3 (1965)



SOIL BORING 053-0062.GPJ IL_DOT_GDT 7/27/22

The Unconfined Compressive Strength (UCS) Failure Mode is indicated by (B-Bulge, S-Shear, P-Penetrometer)
 The SPT (N value) is the sum of the last two blow values in each sampling zone (AASHTO T206)

BRIDGE FOUNDATION BORING LOG

PROJECT _____ BRIDGE SBI 116 over Date June 7, 1965
 ROUTE SBI 116 Scattering Point Creek Bored By C. I. Bassing
 SEC. 112 BR STA. 569+68 Checked By J. E. Safranski

COUNTY Livingston
 Center Pier
 Boring No. #3
 Station 570+07.5
 Offset 25' Lt. E

Elevation	N	Qu t/s.f.	w (%)	Surface Water El.	646.59	Elevation	N	Qu t/s.f.	w (%)
				Groundwater El. at Completion	Wash Bored				
				After --- Hours	---				
Ground Surface	654.49								
Medium Gray Angular Fine to COARSE SAND	613.49								
Very Dense Angular to Sub Angular Fine to Coarse SAND		195	--	--		-25			
	608.49	88	--	--					
Hard Yellowish Brown & Gray CLAY LOAM (Till)		85	4.1 S	13		-30			
	603.99	46	5.8 B	12					
						-35			
						-40			
						-45			

N - Standard Penetration Test - Blows per foot to drive 2" O.D. Split Spoon Sampler 12" with 140# hammer falling 30'.

Qu - Unconfined Compressive Strength - t/sf
 w - Water Content - percentage of oven dry weight - %

Type failure:
 B - Bulge Failure
 S - Shear Failure
 E - Estimated Value

BRIDGE FOUNDATION BORING LOG

PROJECT _____ BRIDGE SBI 116 over Date May 28, 1965
 ROUTE SBI 116 Scatting Point Creek Bored By C. I. Bassing
 SEC. 112 BR STA. 569+68 Checked By J. E. Safranski

COUNTY Livingston
 East Abut. _____
 Boring No. #1
 Station 569+57.5
 Offset 25.5 Rt.

Elevation	N	Qu t/sf.	w (%)	Surface Water El. <u>646.59</u> Groundwater El. at <u>636.20</u> with <u>auger</u> Completion <u>616.90</u> After --- Hours <u>Wash Bored</u>	Elevation	N	Qu t/sf.	w (%)
Ground Surface 650.90	0						5.7	
Stiff Brownish Black SILTY CLAY				Hard Brownish Gray & Gray SILTY CLAY (Till)	21		S	14
	8	1.0 E	31		-25	31	7.2 S	14
647.40								
Very Stiff to Hard Yellowish Brown & Gray CLAY (Till)	-5	2.7 B	22		33	5.7 S	19	
				622.40				
	22	6.4 B	16	Very Stiff Brownish Gray SILTY LOAM	-30	39	2.2 S	18
642.40								
Medium Gray Uniform Fine SAND	-10	--	--		40	2.0 S	18	
				617.40				
638.90				Loose Gray Uniform fine SAND	-35	6	--	--
	10	3.5 B	14		614.90			
Very Stiff Gray CLAY & CLAY LOAM (Till)	-15	3.5 B	15	Very Dense Brown to Gray Angular Coarse SAND	190	--	--	
				612.40				
	22	3.7 S	18	Hard Olive Brown & Gray CLAY & CLAY LOAM (Till)	-40	53	7.4 S	12
632.40								
Hard Brownish Gray & Gray SILTY CLAY (Till)	-20	5.0 B	13					
					-45			

N - Standard Penetration Test -
 Blows per foot to drive 2"
 O.D. Split Spoon Sampler 12" with
 140# hammer falling 30".

Qu - Unconfined Compressive
 Strength - t/sf
 w - Water Content - percentage
 of oven dry weight - %

Type failure:
 B - Bulge Failure
 S - Shear Failure
 E - Estimated Value

BRIDGE FOUNDATION BORING LOG

PROJECT BRIDGE SBI 116 over Date May 28, 1965
 ROUTE SBI 116 Scattering Point Creek Bored By C. I. Bassing
 SEC. 112 BR STA. 569+68 Checked By J. E. Safranski

COUNTY Livingston
 East Abut. #1
 Boring No. #1
 Station 569+57.5
 Offset 25.5' Rt.

	Elevation	N	Qu t/s.f.	w (%)	Surface Water El. 646.59	Elevation	N	Qu t/s.f.	w (%)
Ground Surface	650.90	40			Groundwater El. at <u>636.20 with</u> Completion <u>616.90</u> After --- Hours <u>Wash Bored</u>				
Hard Olive Brown & Gray CLAY & CLAY LOAM (Till)		51	6.4 B	12		-25			
		45	4.6 B	13					
		52	5.8 B	12		-30			
		510	47	5.8 B	13		-35		
	600.40					-40			
						-45			

N - Standard Penetration Test - Blows per foot to drive 2" O.D. Split Spoon Sampler 12" with 140# hammer falling 30".

Qu - Unconfined Compressive Strength - t/sf
 w - Water Content - percentage of oven dry weight - %

Type failure:
 B - Bulge Failure
 S - Shear Failure
 E - Estimated Value

GENERAL DATA

STRUCTURE NUMBER===== 053-0194 (053-0062 Exist.)
 STRUCTURE TYPE ===== MULTI-SPAN
 STRUCTURE SKEW===== 20 DEGREES
 SUPER. DATA IN REFERENCE TO SUB. DATA ===== ABUT 1

TOTAL STRUCTURE LENGTH===== 88.75 FT
 NUMBER OF SPANS ===== 3
 END SPAN LENGTH ===== 27.00 FT
 ADJACENT INTERIOR SPAN LENGTH ===== 34.75 FT

SUPERSTRUCTURE DATA (END OR MAIN SPAN)	
BEAM TYPE =====	SLAB BRIDGE
SLAB THICKNESS =====	16.00 IN
SLAB F'C =====	4.00 KSI

SUPERSTRUCTURE DATA (ADJACENT SPAN)	
SLAB THICKNESS =====	16.00 IN
SLAB F'C =====	4.00 KSI

ABUTMENT #1 DATA	
ABUTMENT NAME =====	West
ABUTMENT REFERENCE BORING =====	B-1 (SW Quad)
BOTTOM OF ABUTMENT ELEVATION =====	651.23 FT
ESTIMATED NUMBER OF PILES AT ABUT. =====	6
PILE SPACING PERP. TO CL =====	7 FT

ABUTMENT #2 DATA	
ABUTMENT NAME =====	East
ABUTMENT REFERENCE BORING =====	B-2 (NE Quad)
BOTTOM OF ABUTMENT ELEVATION =====	651.07 FT
ESTIMATED NUMBER OF PILES AT ABUT. =====	6
PILE SPACING PERP. TO CL =====	7 FT

SOIL DATA FOR 10 FT BENEATH BOTTOM OF ABUTMENT #1				
BOT. OF LAYER ELEV. (FT)	LAYER THICKNESS (FT)	UNCONFINED COMPRESSIVE STRENGTH (TSF)	N S.P.T. VALUE (BLOWS/12 IN.)	Qu EQUIV. FOR N VALUE (TSF)
649.55	1.68	1.3		
646.55	3.00	1.5		
644.05	2.50		21	3.0
642.05	2.00	2.0		
641.23	0.82	3.5		

SOIL DATA FOR 10 FT BENEATH BOTTOM OF ABUTMENT #2				
BOT. OF LAYER ELEV. (FT)	LAYER THICKNESS (FT)	UNCONFINED COMPRESSIVE STRENGTH (TSF)	N S.P.T. VALUE (BLOWS/12 IN.)	Qu EQUIV. FOR N VALUE (TSF)
649.59	1.48	1.8		
647.09	2.50	1.5		
645.09	2.00	1.5		
643.09	2.00	1.00		
642.09	1.00	1.00		
641.07	1.02	3.70		

10.00 FT = TOTAL DEPTH ENTERED

10.00 FT = TOTAL DEPTH ENTERED

WEIGHTED AVERAGE Qu FOR ABUTMENT #1===== 2.10 TSF

WEIGHTED AVERAGE Qu FOR ABUTMENT #2===== 1.62 TSF

PILE STIFFNESS MODIFIER FOR ABUTMENT #1
 = 1/(1.45-[0.3*2.1])===== 1.22

PILE STIFFNESS MODIFIER FOR ABUTMENT #2
 = 1/(1.45-[0.3*1.62])===== 1.04

DISTANCE TO CENTROID OF STIFFNESS FROM ABUTMENT #1 = [1.22*6*0+1.04*6*88.75]/[1.22*6+1.04*6]===== 40.77 FT

DISTANCE TO CENTROID OF STIFFNESS FROM ABUTMENT #2 = [1.04*6*0+1.22*6*88.75]/[1.04*6+1.22*6]===== 47.98 FT

ABUT 1 (West) - EXPANSION LENGTH LIMIT CHART - 20.0 DEG. SKEW

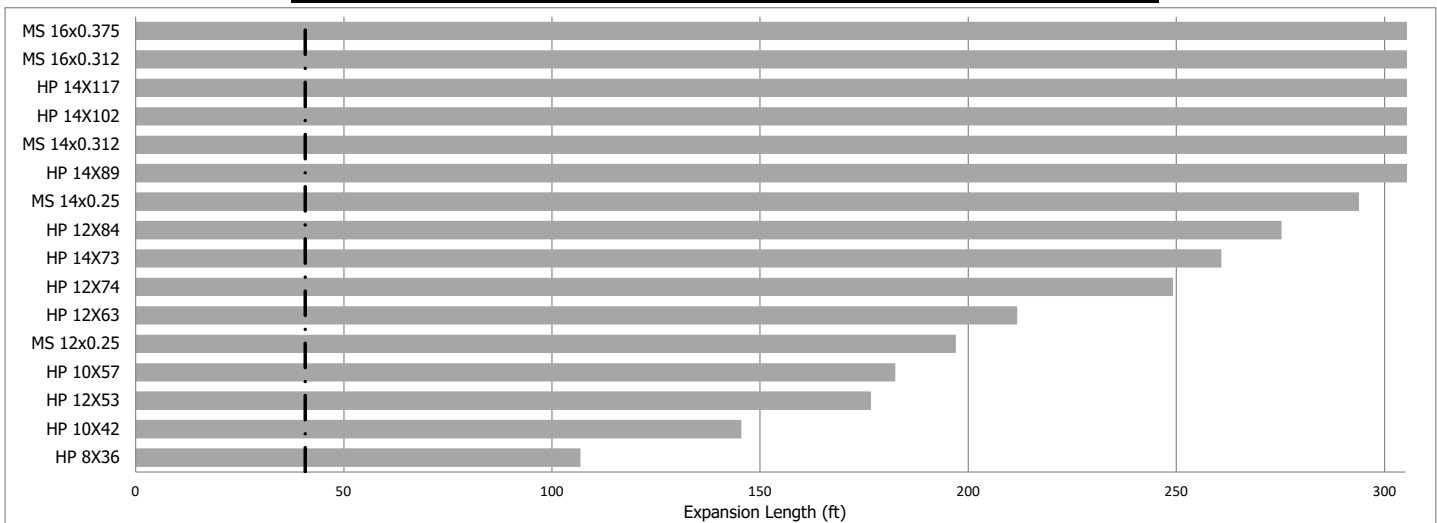

----- = Estimated expansion length for the indicated abutment. Piles with an expansion length greater than this are suitable for consideration.
 (Note: The same size pile should be used at both abutments.)



SEISMIC SITE CLASS DETERMINATION

PROJECT TITLE=====053-0194

West Abutment

Base of Substruct. Elev. (or ground surf for bents) 651.23 ft.
 Pile or Shaft Dia. 12 inches
 Boring Number B-1
 Top of Boring Elev. 656.55 ft.
 Approximate Fixity Elev. 645.23 ft.

Individual Site Class Definition:
 N (bar): 27 (Blows/ft.) Soil Site Class D
 N_{ch} (bar): NA (Blows/ft.) NA
 s_v (bar): 3.87 (ksf) Soil Site Class C <----Controls

Seismic Soil Column Depth (ft)	Bot. Of Sample Elevation (ft)	Sample Thickness (ft)	Sample		Layer Description Boundary
			N (tsf)	Qu (tsf)	
	654.1	2.50	4	1.00	B
	652.1	2.00	6	1.50	
	649.6	2.50	4	1.30	
	646.6	3.00	4	1.50	B
1.2	644.1	2.50	21		B
3.2	642.1	2.00	18	2.00	
5.7	639.6	2.50	15	3.50	
8.2	637.1	2.50	9	2.50	
10.7	634.6	2.50	8	2.00	B
13.2	632.1	2.50	33	3.00	
16.2	629.1	3.00	24	2.50	B
18.2	627.1	2.00	24	4.20	
20.7	624.6	2.50	33	4.40	
25.2	620.1	4.50	31	4.20	
100.0	545.3	74.80	31	4.20	

West Pier

Base of Substruct. Elev. (or ground surf for bents) 640.9 ft.
 Pile or Shaft Dia. 12 inches
 Boring Number B-1
 Top of Boring Elev. 656.55 ft.
 Approximate Fixity Elev. 634.9 ft.

Individual Site Class Definition:
 N (bar): 30 (Blows/ft.) Soil Site Class D
 N_{ch} (bar): (Blows/ft.) NA
 s_v (bar): 4.11 (ksf) Soil Site Class C <----Controls

Seismic Soil Column Depth (ft)	Bot. Of Sample Elevation (ft)	Sample Thickness (ft)	Sample		Layer Description Boundary
			N (tsf)	Qu (tsf)	
	654.1	2.50	4	1.00	B
	652.1	2.00	6	1.50	
	649.6	2.50	4	1.30	
	646.6	3.00	4	1.50	B
	644.1	2.50	21		B
	642.1	2.00	18	2.00	
	639.6	2.50	15	3.50	
	637.1	2.50	9	2.50	
0.4	634.6	2.50	8	2.00	B
2.9	632.1	2.50	33	3.00	
5.9	629.1	3.00	24	2.50	B
7.9	627.1	2.00	24	4.20	
10.4	624.6	2.50	33	4.40	
14.9	620.1	4.50	31	4.20	
100.0	535.0	85.10	31	4.20	

East Pier

Base of Substruct. Elev. (or ground surf for bents) 640.9 ft.
 Pile or Shaft Dia. 12 inches
 Boring Number B-2
 Top of Boring Elev. 656.57 ft.
 Approximate Fixity Elev. 634.9 ft.

Individual Site Class Definition:
 N (bar): 19 (Blows/ft.) Soil Site Class D
 N_{ch} (bar): (Blows/ft.) NA
 s_v (bar): 4.17 (ksf) Soil Site Class C <----Controls

Seismic Soil Column Depth (ft)	Bot. Of Sample Elevation (ft)	Sample Thickness (ft)	Sample		Layer Description Boundary
			N (tsf)	Qu (tsf)	
	654.1	2.50	4	1.00	B
	652.1	2.00	4	1.50	
	649.6	2.50	5	1.80	B
	647.1	2.50	4	1.50	
	645.1	2.00	5	1.50	B
	643.1	2.00	5	1.00	B
	642.1	1.00	5	1.00	
	639.6	2.50	18	3.70	
	637.1	2.50	9	2.20	
0.3	634.6	2.50	11	2.60	B
2.8	632.1	2.50	31	2.50	
5.8	629.1	3.00	18	2.00	B
7.8	627.1	2.00	20	4.20	
10.3	624.6	2.50	26	4.60	
14.8	620.1	4.50	31	4.40	
100.0	534.9	85.20		4.40	

East Abutment

Base of Substruct. Elev. (or ground surf for bents) 651.07 ft.
 Pile or Shaft Dia. 12 inches
 Boring Number B-2
 Top of Boring Elev. 656.57 ft.
 Approximate Fixity Elev. 645.07 ft.

Individual Site Class Definition:
 N (bar): 17 (Blows/ft.) Soil Site Class D
 N_{ch} (bar): (Blows/ft.) NA
 s_v (bar): 3.69 (ksf) Soil Site Class C <----Controls

Seismic Soil Column Depth (ft)	Bot. Of Sample Elevation (ft)	Sample Thickness (ft)	Sample		Layer Description Boundary
			N (tsf)	Qu (tsf)	
	654.1	2.50	4	1.00	B
	652.1	2.00	4	1.50	
	649.6	2.50	5	1.80	B
	647.1	2.50	4	1.50	
	645.1	2.00	5	1.50	B
2.0	643.1	2.00	5	1.00	B
3.0	642.1	1.00	5	1.00	
5.5	639.6	2.50	18	3.70	
8.0	637.1	2.50	9	2.20	
10.5	634.6	2.50	11	2.60	B
13.0	632.1	2.50	31	2.50	
16.0	629.1	3.00	18	2.00	B
18.0	627.1	2.00	20	4.20	
20.5	624.6	2.50	26	4.60	
25.0	620.1	4.50	31	4.40	
100.0	545.1	75.00		4.40	

Global Site Class Definition: Substructures 1 through 4

N (bar): 23 (Blows/ft.) Soil Site Class D
 N_{ch} (bar): (Blows/ft.) NA, H < 0.1*H (Total)
 s_v (bar): 3.96 (ksf) Soil Site Class C <----Controls

Pile Design Table for West Abutment utilizing Boring #B-01 (SW Quad)

Nominal Required Bearing (Kips)	Factored Resistance Available (Kips)	Estimated Pile Length (Ft.)
--	---	--------------------------------------

Nominal Required Bearing (Kips)	Factored Resistance Available (Kips)	Estimated Pile Length (Ft.)
--	---	--------------------------------------

Metal Shell 14" Φ w/.312" walls		
137	76	19
153	84	21
197	108	24
336	185	26
343	189	29
352	194	30
359	197	31
365	201	32
487	268	33
501	275	34
514	283	35
570	314	36
Metal Shell 16" Φ w/.312" walls		
114	63	14
128	71	16
163	90	19
180	99	21
233	128	24
412	226	26
418	230	29
428	236	30
435	240	31
443	243	32
601	331	33
654	360	34

Metal Shell 16" Φ w/.375" walls		
128	71	16
163	90	19
180	99	21
233	128	24
412	226	26
418	230	29
428	236	30
435	240	31
443	243	32
601	331	33
617	339	34
632	347	35
782	430	36

Pile Design Table for East Abutment utilizing Boring #B-02 (NE Quad)

Nominal Required Bearing (Kips)	Factored Resistance Available (Kips)	Estimated Pile Length (Ft.)
--	---	--------------------------------------

Nominal Required Bearing (Kips)	Factored Resistance Available (Kips)	Estimated Pile Length (Ft.)
--	---	--------------------------------------

Metal Shell 14" Φ w/.312" walls		
121	67	16
140	77	19
153	84	21
199	110	24
226	125	26
270	149	35
277	152	36
284	156	37
357	196	37
362	199	38
367	202	39
570	314	40
Metal Shell 16" Φ w/.312" walls		
117	64	14
143	79	16
165	91	19
179	98	21
236	130	24
268	147	26
313	172	35
321	176	36
329	181	37
424	233	37
429	236	38
435	239	39
654	360	40

Metal Shell 16" Φ w/.375" walls		
117	64	14
143	79	16
165	91	19
179	98	21
236	130	24
268	147	26
313	172	35
321	176	36
329	181	37
424	233	37
429	236	38
435	239	39
782	430	40

Pile Design Table for West Pier utilizing Boring #B-01 (SW Quad)

Nominal Required Bearing (Kips)	Factored Resistance Available (Kips)	Estimated Pile Length (Ft.)
--	---	--------------------------------------

Metal Shell 14" Φ w/.312" walls		
144	79	24
284	156	26
290	160	29
300	165	30
306	168	31
312	172	32
434	239	33
448	246	34
461	254	35
570	314	36

Metal Shell 16" Φ w/.312" walls		
172	95	24
351	193	26
357	196	29
368	202	30
375	206	31
382	210	32
541	297	33
556	306	34
571	314	35
654	360	34

Nominal Required Bearing (Kips)	Factored Resistance Available (Kips)	Estimated Pile Length (Ft.)
--	---	--------------------------------------

Metal Shell 16" Φ w/.375" walls		
172	95	24
351	193	26
357	196	29
368	202	30
375	206	31
382	210	32
541	297	33
556	306	34
571	314	35
782	430	36

Pile Design Table for East Pier utilizing Boring #B-02 (NE Quad)

Nominal Required Bearing (Kips)	Factored Resistance Available (Kips)	Estimated Pile Length (Ft.)
--	---	--------------------------------------

Nominal Required Bearing (Kips)	Factored Resistance Available (Kips)	Estimated Pile Length (Ft.)
--	---	--------------------------------------

Metal Shell 14"Φ w/.312" walls		
140	77	24
167	92	26
211	116	35
218	120	36
225	124	37
298	164	37
303	167	38
308	169	39
570	314	40
Metal Shell 16"Φ w/.312" walls		
111	61	21
168	92	24
200	110	26
245	135	35
253	139	36
261	144	37
356	196	37
362	199	38
368	202	39
654	360	40

Metal Shell 16"Φ w/.375" walls		
111	61	21
168	92	24
200	110	26
245	135	35
253	139	36
261	144	37
356	196	37
362	199	38
368	202	39
782	430	40

Soil Type	Elevation	Angle of Internal Friction (degrees)	Average Undrained Cohesion (ksf)	Static Soil Modulus k (pci)	Soil Strain Parameter E50	Total Unit Wt. (pcf)	Effective Unit Wt. (pcf)
Augered Black Silty Clay Loam	656.57 - 654.07	-	1.0	100	0.01	120	57.6
Stiff Black Silty Clay Loam Fill	654.07 - 649.57	-	1.5	500	0.007	120	57.6
Stiff Gray and Brown Silty Clay Loess	649.57 - 645.07	-	1.5	500	0.007	120	57.6
Stiff Brown Silty Clay Loam	645.07 - 643.07	-	1.0	500	0.007	120	57.6
Very Stiff Gray Silty Clay Loam Till	643.07 - 634.57	-	2.2	1000	0.005	122	59.6
Very Stiff Gray Silty	634.57 - 629.07	-	2.0	1000	0.005	120	57.6
Hard Olive Gray Silty Loam Till	629.07 - 620.07	-	4.2	2000	0.004	120	57.6

SCOUR ANALYSIS FOR NON-GRANULAR CONDITIONS

I.D.O.T. BBS FOUNDATIONS AND GEOTECHNICAL UNIT

Modified 5/28/2015

STRUCTURE NUMBER ===== 053-0194
 SUBSTRUCTURE UNIT ===== PIER 1 (West)
 BORING LOCATION RELATIVE TO SUBSTRUCTURE UNIT ===== NEAR
 BOTTOM OF SUBSTRUCTURE ELEVATION ===== 640.9
 GROUND SURFACE ELEVATION AT SUBSTRUCTURE ===== 643.4
 Q100 SCOUR DEPTH AT SUBSTRUCTURE PER APPROVED HYDRAULIC REPORT (HR Q100) ===== 6.08 FT
 Q200 SCOUR DEPTH AT SUBSTRUCTURE PER APPROVED HYDRAULIC REPORT (HR Q200) ===== 6.12 FT

LAYER NO.	BOTTOM OF LAYER ELEV. (FT)	DEPTH BELOW SURFACE (FT)	LAYER THICK. (FT)	Qu VALUE (TSF)	ROCK TYPE (IF APPLICABLE)	SCOUR REDUCTION (%)	SCOUR RESISTANCE OF LAYER (FT)	REMAINING Q100 SCOUR BELOW LAYER (FT)	REMAINING Q200 SCOUR BELOW LAYER (FT)
1	639.4	4.0	4.0	0.00		0%	4.00	2.08	2.12
2	637.0	6.4	2.4	2.50		50%	4.80	0.00	0.00
3	634.5	8.9	2.5	2.00		50%	5.00		
4	632.0	11.4	2.5	3.00		50%	5.00		
5	629.0	14.4	3.0	2.50		50%	6.00		
6	627.0	16.4	2.0	4.20		50%	4.00		
7	622.0	21.4	5.0	4.40		50%	10.00		
8	620.0	23.4	2.0	4.20		50%	4.00		

SCOUR FIGURE

STRENGTH LIMIT STATE ADJUSTED SCOUR (ADJ. Q100)

UNADJUSTED Q100 SCOUR DEPTH ===== 637.3 FT
 LAYER IN WHICH ADJUSTED Q100 SCOUR STOPS ===== LAYER 2
 DEPTH INTO LAYER 2 AT WHICH SCOUR STOPS ===== 1.0 FT
 DEPTH BELOW GROUND SURFACE TO ADJUSTED Q100 SCOUR ===== 5.0 FT
 TOTAL % ADJUSTMENT OF Q100 SCOUR = $[1 - (5.04/6.08)] * 100 = 17.1\%$
 Q100 SCOUR ELEVATION ===== **638.4** FT

EXTREME EVENT II ADJUSTED SCOUR (ADJ. Q200)

UNADJUSTED Q200 SCOUR DEPTH ===== 637.3 FT
 LAYER IN WHICH ADJUSTED Q200 SCOUR STOPS ===== LAYER 2
 DEPTH INTO LAYER 2 AT WHICH SCOUR STOPS ===== 1.1 FT
 DEPTH BELOW GROUND SURFACE OF ADJUSTED Q200 SCOUR ===== 5.1 FT
 TOTAL % ADJUSTMENT OF Q200 SCOUR = $[1 - (5.06/6.12)] * 100 = 17.3\%$
 Q200 SCOUR ELEVATION ===== **638.3** FT

643.4 GROUND SURFACE ELEVATION



LEGEND FOR SCOUR FIGURE

- ADJUSTED Q100 SCOUR
- RAW Q100 SCOUR PER APPROVED HYDRAULIC REPORT
- ADJUSTED Q200 SCOUR
- RAW Q200 SCOUR PER APPROVED HYDRAULIC REPORT

SCOUR ANALYSIS FOR NON-GRANULAR CONDITIONS

I.D.O.T. BBS FOUNDATIONS AND GEOTECHNICAL UNIT

Modified 5/28/2015

STRUCTURE NUMBER ===== 053-0194
 SUBSTRUCTURE UNIT ===== PIER 2 (East)
 BORING LOCATION RELATIVE TO SUBSTRUCTURE UNIT ===== NEAR
 BOTTOM OF SUBSTRUCTURE ELEVATION ===== 640.9
 GROUND SURFACE ELEVATION AT SUBSTRUCTURE ===== 643.4
 Q100 SCOUR DEPTH AT SUBSTRUCTURE PER APPROVED HYDRAULIC REPORT (HR Q100) ===== 6.08 FT
 Q200 SCOUR DEPTH AT SUBSTRUCTURE PER APPROVED HYDRAULIC REPORT (HR Q200) ===== 6.12 FT

LAYER NO.	BOTTOM OF LAYER ELEV. (FT)	DEPTH BELOW SURFACE (FT)	LAYER THICK. (FT)	Qu VALUE (TSF)	ROCK TYPE (IF APPLICABLE)	SCOUR REDUCTION (%)	SCOUR RESISTANCE OF LAYER (FT)	REMAINING Q100 SCOUR BELOW LAYER (FT)	REMAINING Q200 SCOUR BELOW LAYER (FT)
1	639.4	4.0	4.0	0.00		0%	4.00	2.08	2.12
2	637.1	6.3	2.3	2.20		50%	4.60	0.00	0.00
3	634.6	8.8	2.5	2.60		50%	5.00		
4	632.1	11.3	2.5	2.50		50%	5.00		
5	629.1	14.3	3.0	2.00		50%	6.00		
6	627.1	16.3	2.0	4.20		50%	4.00		
7	622.1	21.3	5.0	4.60		50%	10.00		
8	620.1	23.3	2.0	4.40		50%	4.00		
9	618.1	25.3	2.0	4.40		50%	4.00		

SCOUR FIGURE

STRENGTH LIMIT STATE ADJUSTED SCOUR (ADJ. Q100)

UNADJUSTED Q100 SCOUR DEPTH ===== 637.3 FT
 LAYER IN WHICH ADJUSTED Q100 SCOUR STOPS ===== LAYER 2
 DEPTH INTO LAYER 2 AT WHICH SCOUR STOPS ===== 1.0 FT
 DEPTH BELOW GROUND SURFACE TO ADJUSTED Q100 SCOUR ===== 5.0 FT
 TOTAL % ADJUSTMENT OF Q100 SCOUR = $[1 - (5.04/6.08)] * 100 = 17.1\%$
 Q100 SCOUR ELEVATION ===== **638.4** FT

EXTREME EVENT II ADJUSTED SCOUR (ADJ. Q200)





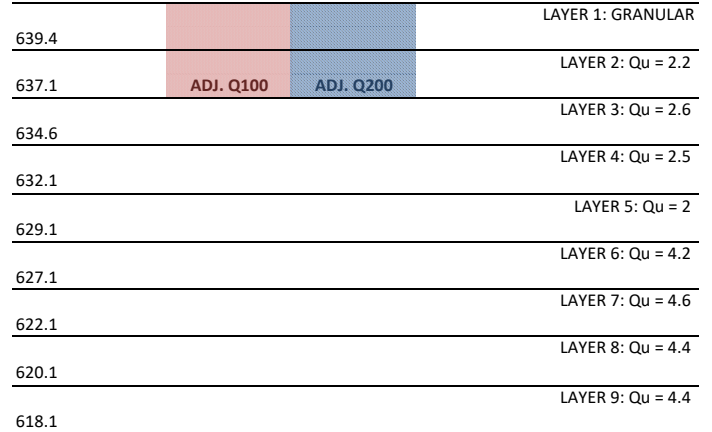



UNADJUSTED Q200 SCOUR DEPTH ===== 637.3 FT
 LAYER IN WHICH ADJUSTED Q200 SCOUR STOPS ===== LAYER 2
 DEPTH INTO LAYER 2 AT WHICH SCOUR STOPS ===== 1.1 FT
 DEPTH BELOW GROUND SURFACE OF ADJUSTED Q200 SCOUR ===== 5.1 FT
 TOTAL % ADJUSTMENT OF Q200 SCOUR = $[1 - (5.06/6.12)] * 100 = 17.3\%$
 Q200 SCOUR ELEVATION ===== **638.3** FT

643.4 GROUND SURFACE ELEVATION



LEGEND FOR SCOUR FIGURE

ADJUSTED Q100 SCOUR
 RAW Q100 SCOUR PER APPROVED HYDRAULIC REPORT
 ADJUSTED Q200 SCOUR
 RAW Q200 SCOUR PER APPROVED HYDRAULIC REPORT

Material Name	Color	Unit Weight (lbs/ft3)	Strength Type	Cohesion (psf)	Phi (deg)	Allow Sliding	Water Surface	Ru
Augered Black Silty Clay Loam		120	Mohr-Coulomb	0	29		None	0
Stiff Black Silty Clay Loam Fill		120	Mohr-Coulomb	0	30		None	0
Stiff Gray and Brown Silty Clay Loess		120	Mohr-Coulomb	0	30		None	0
Stiff Brown Silty Clay Loam		120	Mohr-Coulomb	0	29		None	0
Very Stiff Gray Silty Clay Loam Till		122	Mohr-Coulomb	0	31		None	0
Very Stiff Gray Silt		120	Mohr-Coulomb	0	33		None	0
Hard Olive Gray Silty Loam Till		120	Mohr-Coulomb	0	34		None	0
Concrete		145	Infinite strength			No	None	0
Riprap		135	Mohr-Coulomb	0	40		None	0

Long Term Slope Failure Analysis (Drained) - 66L79
SN: 053-0194
 Boring No.: 01 (SW Quad.)

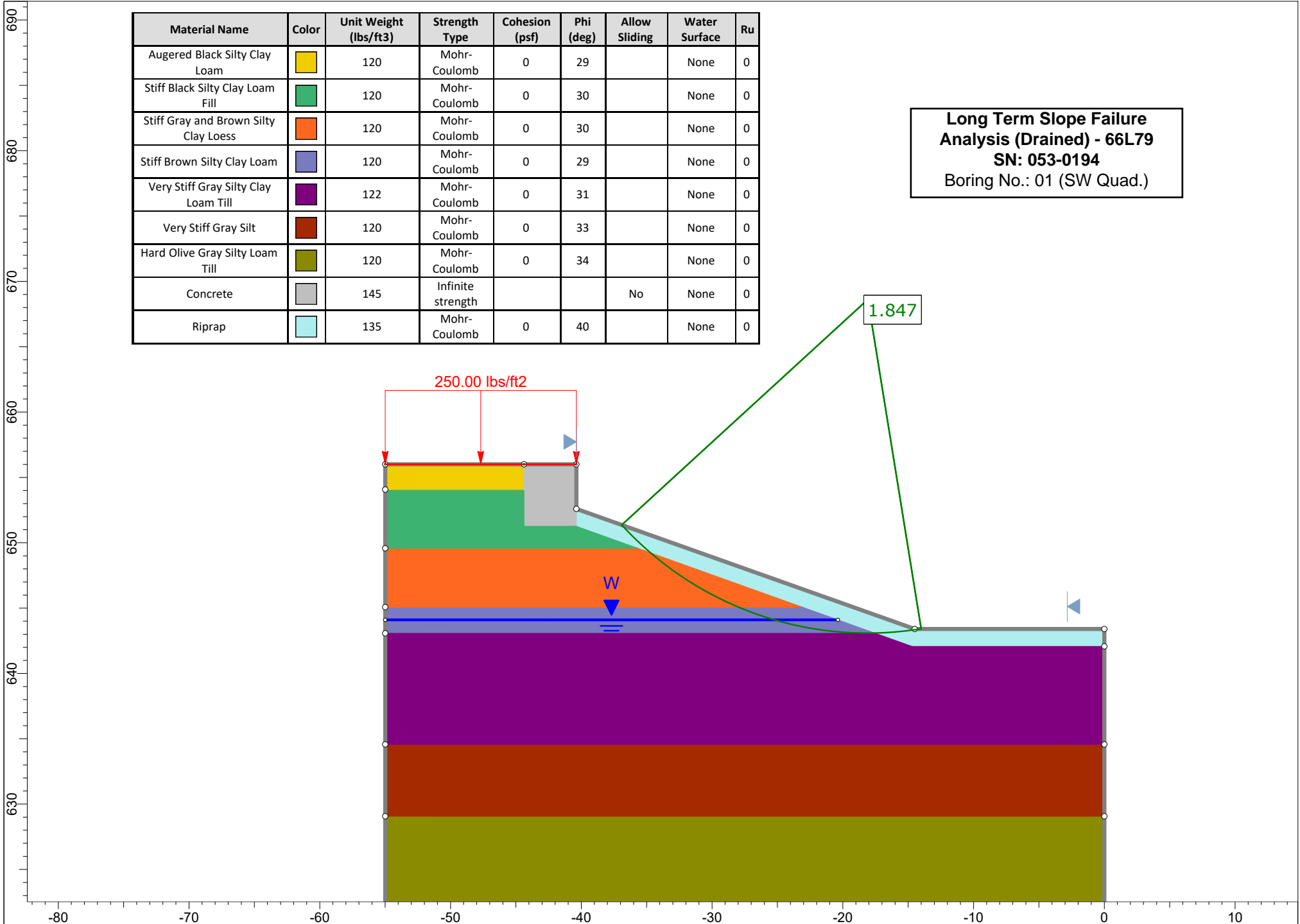

**Short Term Slope Failure
Analysis - 66L79**
SN: 053-0194
 Boring No.: 01 (SW Quad.)

Material Name	Color	Unit Weight (lbs/ft3)	Strength Type	Cohesion (psf)	Phi (deg)	Allow Sliding	Water Surface	Ru
Augered Black Silty Clay Loam		120	Mohr-Coulomb	1000	0		None	0
Stiff Black Silty Clay Loam Fill		120	Mohr-Coulomb	1500	0		None	0
Stiff Gray and Brown Silty Clay Loess		120	Mohr-Coulomb	1500	0		None	0
Stiff Brown Silty Clay Loam		120	Mohr-Coulomb	1000	0		None	0
Very Stiff Gray Silty Clay Loam Till		122	Mohr-Coulomb	2200	0		None	0
Very Stiff Gray Silt		120	Mohr-Coulomb	2000	0		None	0
Hard Olive Gray Silty Loam Till		120	Mohr-Coulomb	5000	0		None	0
Concrete		145	Infinite strength			No	None	0
Riprap		135	Mohr-Coulomb	0	40		None	0

2.363

