

STATE OF ILLINOIS
DEPARTMENT OF TRANSPORTATION

PROPOSED
HIGHWAY PLANS

VARIOUS ROUTES
SECTION DIST 8 LITTER REMOVAL 2025-1

LITTER REMOVAL
VARIOUS COUNTIES

C-98-169-24

FOR INDEX OF SHEETS, SEE SHEET NO. 2

F.A. RTE.	SECTION	COUNTY	TOTAL SHEETS	SHEET NO.
VAR	DIST 8 LITTER REMOVAL 2025-1	VARIOUS	15	1
		ILLINOIS	CONTRACT NO. 76U12	

D-98-087-24

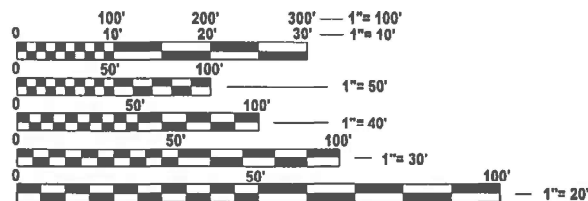
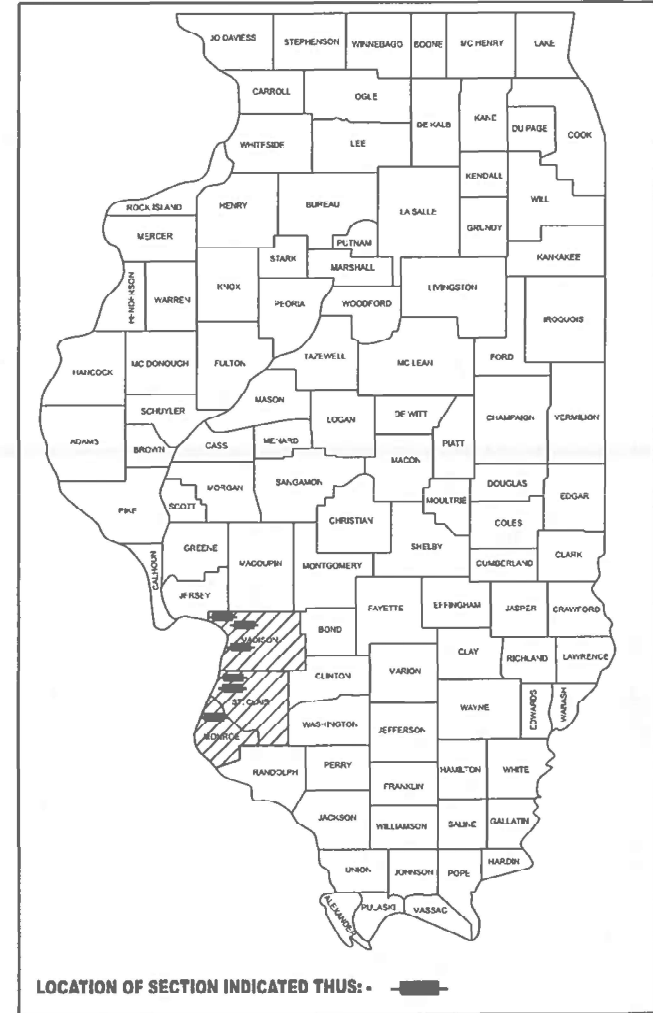

FULL SIZE PLANS HAVE BEEN PREPARED USING STANDARD ENGINEERING SCALES. REDUCED SIZED PLANS WILL NOT CONFORM TO STANDARD SCALES. IN MAKING MEASUREMENTS ON REDUCED PLANS, THE ABOVE SCALES MAY BE USED.

J.U.L.I.E.
JOINT UTILITY LOCATION INFORMATION FOR EXCAVATION
1-800-892-0123
OR 811

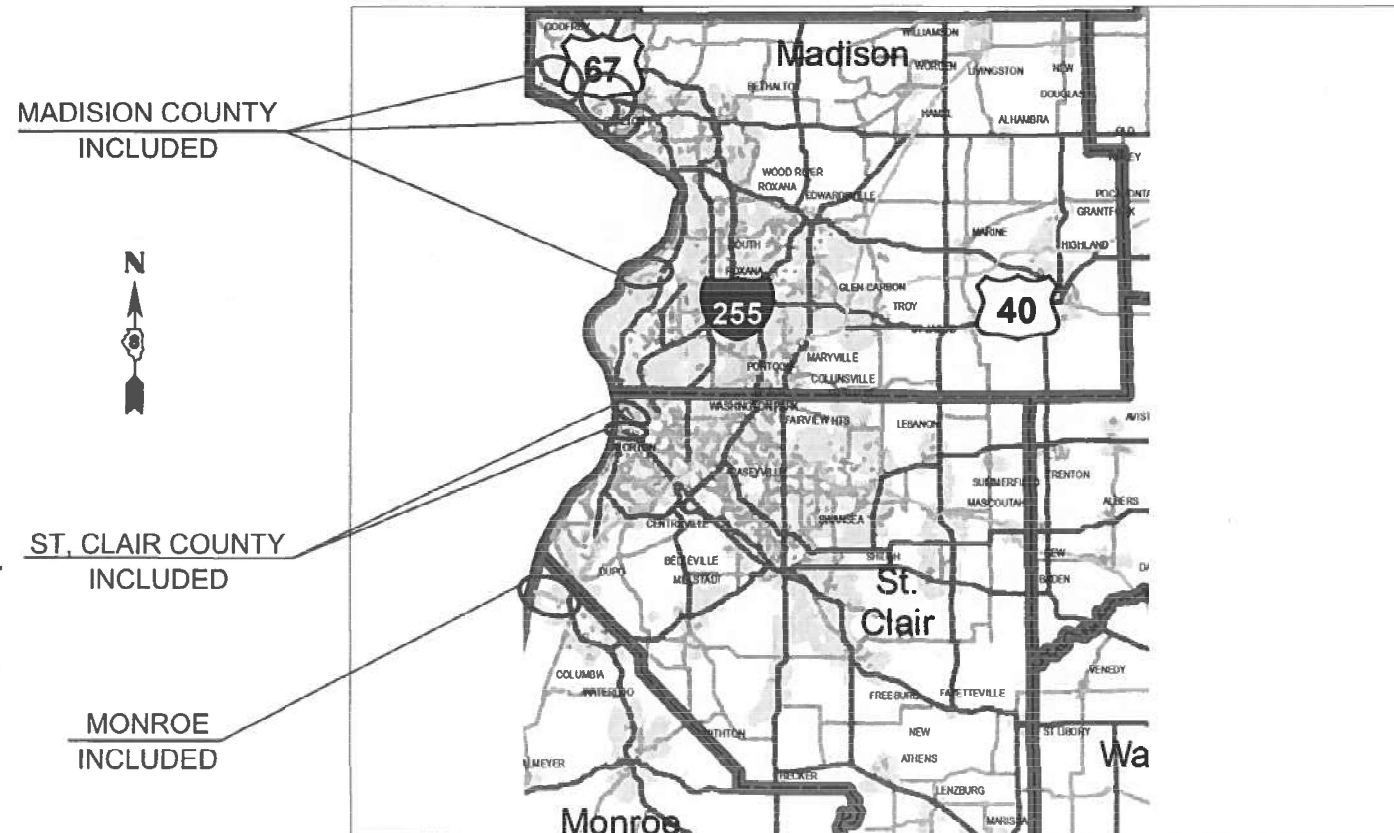

PROJECT ENGINEER - CHERYL KEPLAR
PROJECT MANAGER - TONI MANN

CONTRACT NO. 76U12

GROSS LENGTH = 82526.4 FT. = 15.63 MILE
NET LENGTH = 82526.4 FT. = 15.63 MILE

STATE OF ILLINOIS
DEPARTMENT OF TRANSPORTATION

SUBMITTED *Aug 22 2024*
Kit H B
REGIONAL ENGINEER

October 4, 2024
Scott A. Elk
ENGINEER OF DESIGN AND ENVIRONMENT

October 4, 2024
James J. Jan
DIRECTOR OF HIGHWAYS PROJECT IMPLEMENTATION

PRINTED BY THE AUTHORITY
OF THE STATE OF ILLINOIS

INDEX OF SHEETS

1. COVER SHEET
2. GENERAL NOTES, INDEX OF SHEETS, HIGHWAY STANDARDS AND SIGNATURES
3. SUMMARY OF QUANTITIES
- 4-6. LOCATION MAPS
- 7-14. TYPICALS
15. LITTER PICKING SCHEDULES

GENERAL NOTES

1. ALL SHOULDER CLOSURES SHALL BE IMMEDIATELY REMOVED DURING ALL ADVERSE WEATHER CONDITIONS WITHOUT EXCEPTIONS. THIS INCLUDES, BUT IS NOT LIMITED TO RAIN, WET ROAD SURFACE (SPRAY FROM TIRES), MIST, DRIZZLE, SLEET, SNOW, FOG ANY OTHER CIRCUMSTANCE DETERMINED UNSAFE BY THE ENGINEER. THE CONTRACTOR SHALL IMPLEMENT THIS CONTRACT REQUIREMENT IMMEDIATELY WITHOUT WAITING FOR DEPARTMENT INSTRUCTIONS.
2. NO NIGHTTIME WORK WILL BE ALLOWED ON THIS CONTRACT.
3. ALL EXCAVATED EARTHEN MATERIAL MUST REMAIN ON SITE.

IDOT HIGHWAY STANDARDS

- | | |
|-----------|---|
| 701101-05 | OFF-ROAD PAVEMENT OPERATIONS, EDGE MULTILANE 15' (4.5 m) TO 24" (600 mm) FROM PAVEMENT EDGE |
| 701106-02 | OFF-ROAD OPERATIONS, MULTI LANE, MORE THAN 15' (4.5m) AWAY |
| 701400-12 | APPROACH TO LANE CLOSURE, FREEWAY/EXPRESSWAY |
| 701401-13 | LANE CLOSURE FREEWAY/EXPRESSWAY |
| 701426-09 | LANE CLOSURE MULTILANE, INTERMITTENT OR MOVING OPERATIONS FOR SPEEDS ≥ 45 MPH |
| 701456-05 | PARTIAL EXIT RAMP CLOSURE, FREEWAY/EXPRESSWAY |
| 701901-09 | TRAFFIC CONTROL DEVICES |
| 000001-08 | STANDARD SYMBOLS, ABBREVIATIONS AND PATTERNS |
| 001006 | DECIMAL OF AN INCH AND OF A FOOT |
| 701428-01 | TRAFFIC CONTROL, SETUP AND REMOVAL, FREEWAY/EXPRESSWAY |

COMMITMENTS

NONE

REV - MS

MODEL: General Notes (Sheet)
FILE NAME: c:\pwworking\lewis\cal0892589\0876112_sht-gennote.dgn

<table border="1" style="width: 100%; border-collapse: collapse;"> <tr> <td style="font-size: small;">USER NAME = Kevin.Lewis</td> <td style="font-size: small;">DESIGNED -</td> <td style="font-size: small;">REVISED -</td> </tr> <tr> <td style="font-size: small;">DRAWN -</td> <td style="font-size: small;">REVISED -</td> <td></td> </tr> <tr> <td style="font-size: small;">CHECKED -</td> <td style="font-size: small;">REVISED -</td> <td></td> </tr> <tr> <td style="font-size: small;">PLOT DATE = 8/5/2024</td> <td style="font-size: small;">DATE -</td> <td style="font-size: small;">REVISED -</td> </tr> </table>	USER NAME = Kevin.Lewis	DESIGNED -	REVISED -	DRAWN -	REVISED -		CHECKED -	REVISED -		PLOT DATE = 8/5/2024	DATE -	REVISED -	STATE OF ILLINOIS DEPARTMENT OF TRANSPORTATION	INDEX OF SHEETS, GENERAL NOTES, HIGHWAY STANDARDS, AND COMMITMENTS	<table border="1" style="width: 100%; border-collapse: collapse;"> <tr> <th style="text-align: left;">F.A. RTE.</th> <th style="text-align: left;">SECTION</th> <th style="text-align: left;">COUNTY</th> <th style="text-align: center;">TOTAL SHEETS</th> <th style="text-align: center;">SHEET NO.</th> </tr> <tr> <td>VAR</td> <td>DIST 8 LITTER REMOVAL 2025-1</td> <td>VARIOUS</td> <td style="text-align: center;">15</td> <td style="text-align: center;">2</td> </tr> <tr> <td colspan="3"></td> <td colspan="2" style="text-align: center;">CONTRACT NO. 76U12</td> </tr> <tr> <td colspan="2"></td> <td style="text-align: center;">ILLINOIS</td> <td colspan="2" style="text-align: center;">FED. AID PROJECT</td> </tr> </table>	F.A. RTE.	SECTION	COUNTY	TOTAL SHEETS	SHEET NO.	VAR	DIST 8 LITTER REMOVAL 2025-1	VARIOUS	15	2				CONTRACT NO. 76U12				ILLINOIS	FED. AID PROJECT	
USER NAME = Kevin.Lewis	DESIGNED -	REVISED -																																	
DRAWN -	REVISED -																																		
CHECKED -	REVISED -																																		
PLOT DATE = 8/5/2024	DATE -	REVISED -																																	
F.A. RTE.	SECTION	COUNTY	TOTAL SHEETS	SHEET NO.																															
VAR	DIST 8 LITTER REMOVAL 2025-1	VARIOUS	15	2																															
			CONTRACT NO. 76U12																																
		ILLINOIS	FED. AID PROJECT																																
SCALE:		SHEET OF 1 SHEETS	STA. TO STA.																																

MODEL: SOQ (Sheet)
 FILE NAME: c:\p\work\pwl\lewis\kad0892599\08761712-sht-SOQ.dgn

100% STATE

CODE NO.	ITEM	UNIT	TOTAL QUANTITY	CONSTR. CODE	
				NONE	URBAN
67100100	MOBILIZATION	L SUM	1	1	
X0326643	LITTER PICKING	MILE	15.63	15.63	

USER NAME = Kevin.Lewis	DESIGNED -	REVISED -
	DRAWN -	REVISED -
	CHECKED -	REVISED -
PLOT DATE = 7/16/2024	DATE -	REVISED -

**STATE OF ILLINOIS
 DEPARTMENT OF TRANSPORTATION**

SUMMARY OF QUANTITIES

SCALE: SHEET OF 1 SHEETS STA. TO STA.

F.A. RTE.	SECTION	COUNTY	TOTAL SHEETS	SHEET NO.
VAR	DIST 8 LITTER REMOVAL 2025-1	VARIOUS	15	3
			CONTRACT NO. 76U12	
			ILLINOIS FED. AID PROJECT	

I-270: MISSISSIPPI RIVER TO IL3

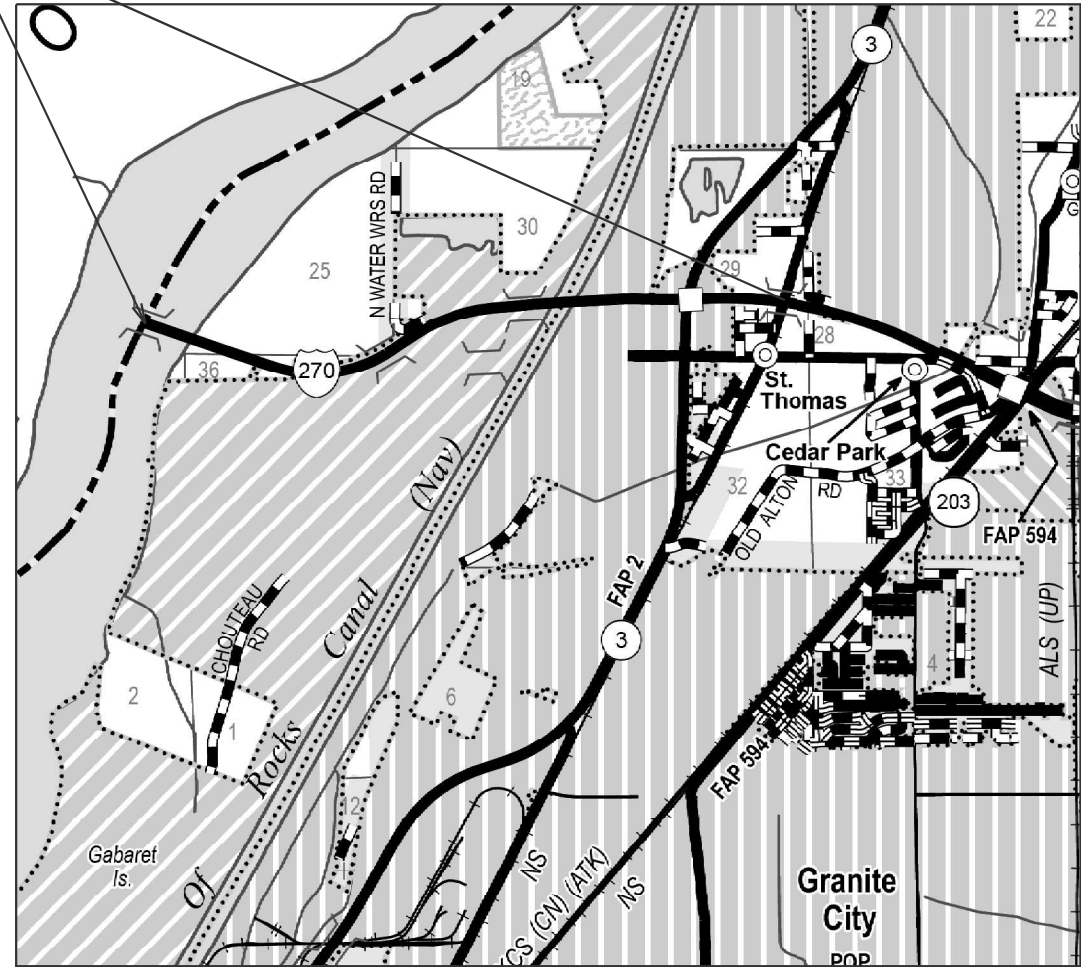
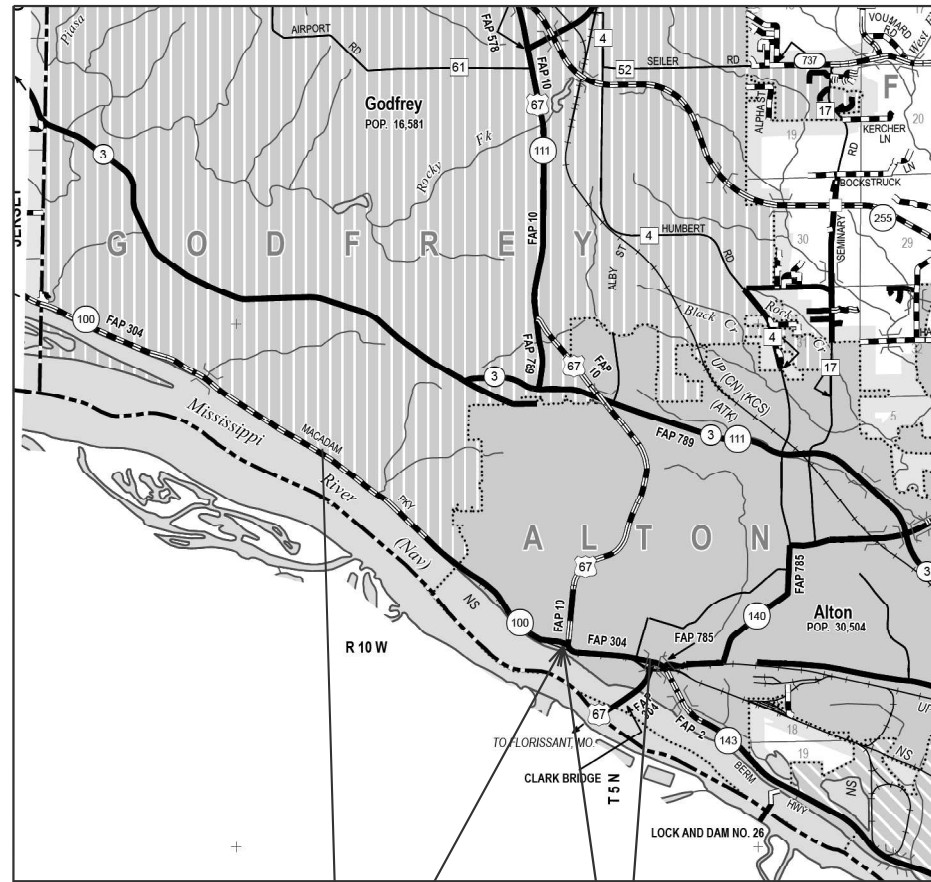

IL 100: HOFFMAN GARDENS TO US 67
2.82 MILES

US 67: IL 100 TO IL 143
0.83 MILES

MODEL: Madison (Sheet)
FILE NAME: c:\p\work\lewis\skad0892599\0876\172-shr-plan.dgn

USER NAME = Kevin.Lewis	DESIGNED -	REVISED -
	DRAWN -	REVISED -
	CHECKED -	REVISED -
PLOT DATE = 8/1/2024	DATE -	REVISED -

STATE OF ILLINOIS
DEPARTMENT OF TRANSPORTATION

MADISON COUNTY
LOCATION MAP

SCALE: SHEET OF 3 SHEETS STA. TO STA.

F.A. RTE.	SECTION	COUNTY	TOTAL SHEETS	SHEET NO.
VAR	DIST 8 LITTER REMOVAL 2025-1	VARIOUS	15	4
CONTRACT NO. 76U12				
ILLINOIS FED. AID PROJECT				

I-255: MISSISSIPPI RIVER TO IL 3
3.21 MILES

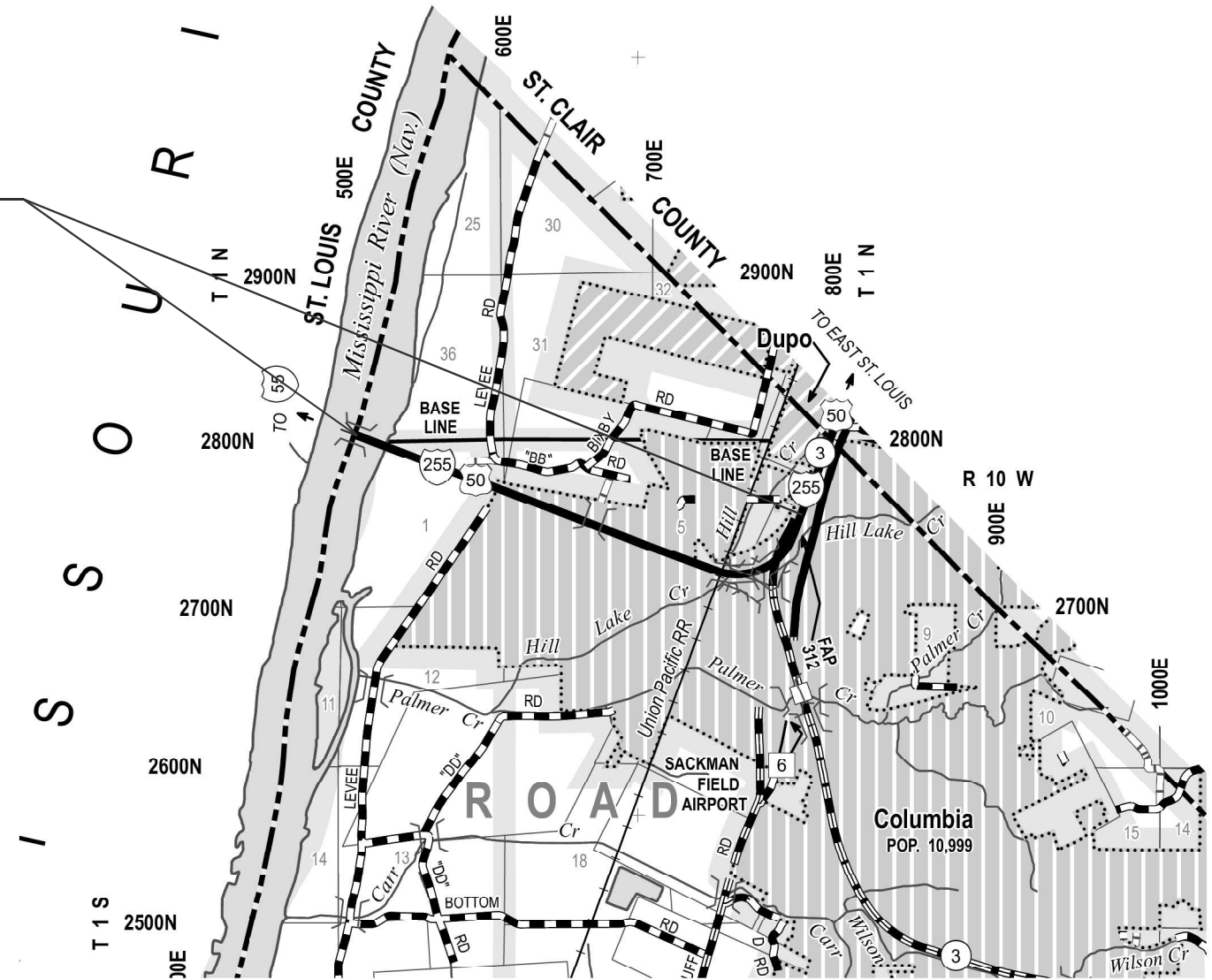

MODEL: Monroe (Sheet)
FILE NAME: c:\p\work\lewis\skad0892599\0876112-shl-plan.dgn

USER NAME = Kevin.Lewis	DESIGNED -	REVISED -
	DRAWN -	REVISED -
	CHECKED -	REVISED -
PLOT DATE = 8/6/2024	DATE -	REVISED -

STATE OF ILLINOIS
DEPARTMENT OF TRANSPORTATION

MONROE COUNTY
LOCATION MAP

SCALE: SHEET OF 3 SHEETS STA. TO STA.

F.A. RTE.	SECTION	COUNTY	TOTAL SHEETS	SHEET NO.
VAR	DIST 8 LITTER REMOVAL 2025-1	VARIOUS	15	5
			CONTRACT NO. 76U12	
ILLINOIS FED. AID PROJECT				

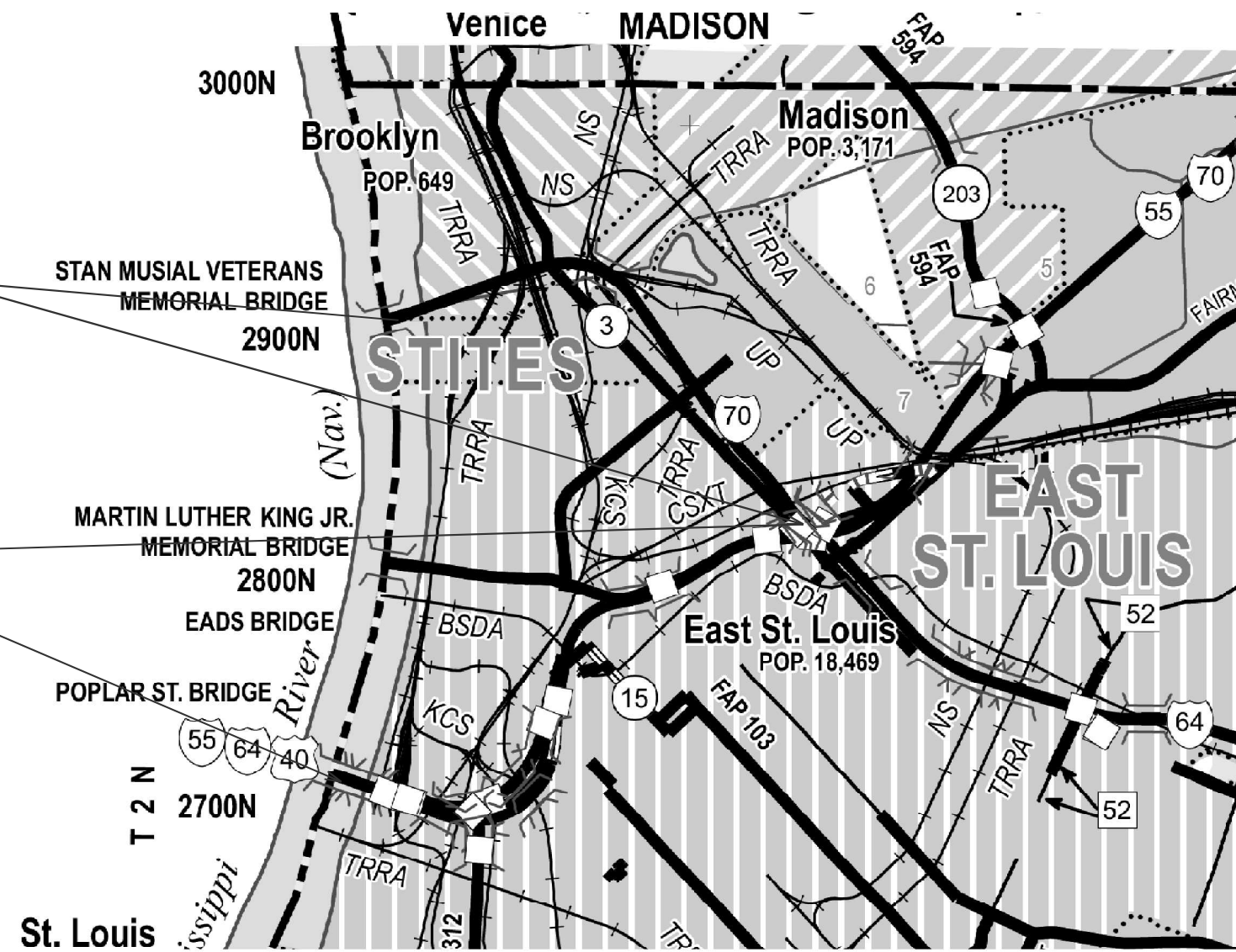

I-70: MISSISSIPPI RIVER TO I-55/64
2.80 MILES

I-55/64: MISSISSIPPI RIVER TO I-70
3.07 MILES

MODEL: St. Clair (Sheet)
FILE NAME: c:\p\work\lewis\stclair\0892599\0876172-stcl-clan.dgn

USER NAME = Kevin.Lewis	DESIGNED -	REVISED -
	DRAWN -	REVISED -
	CHECKED -	REVISED -
PLOT DATE = 8/6/2024	DATE -	REVISED -

**STATE OF ILLINOIS
DEPARTMENT OF TRANSPORTATION**

**ST. CLAIR COUNTY
LOCATION MAP**

SCALE: SHEET OF 3 SHEETS STA. TO STA.

F.A. RTE.	SECTION	COUNTY	TOTAL SHEETS	SHEET NO.
VAR	DIST 8 LITTER REMOVAL 2025-1	VARIOUS	15	6
			CONTRACT NO. 76U12	
ILLINOIS FED. AID PROJECT				

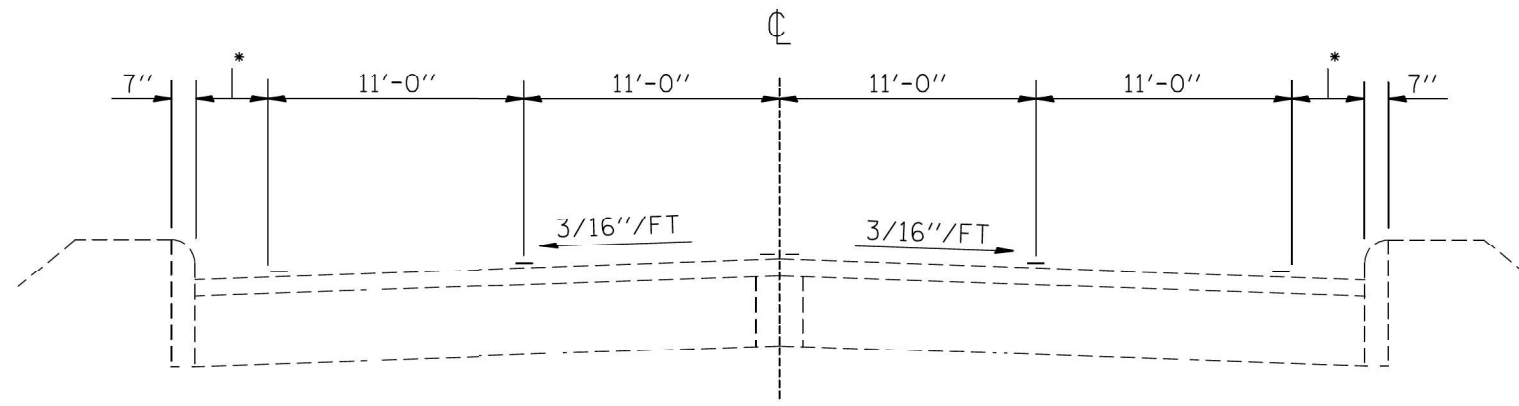

TYPICAL SECTION
M.S. 0.0 TO M.S. 0.529

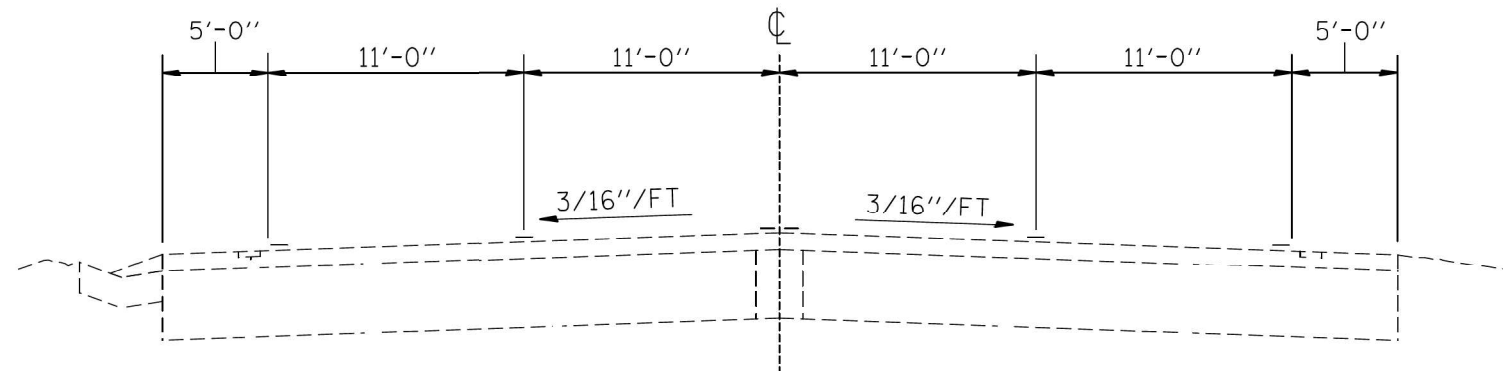

TYPICAL SECTION
M.S. 0.529 TO M.S. 0.685

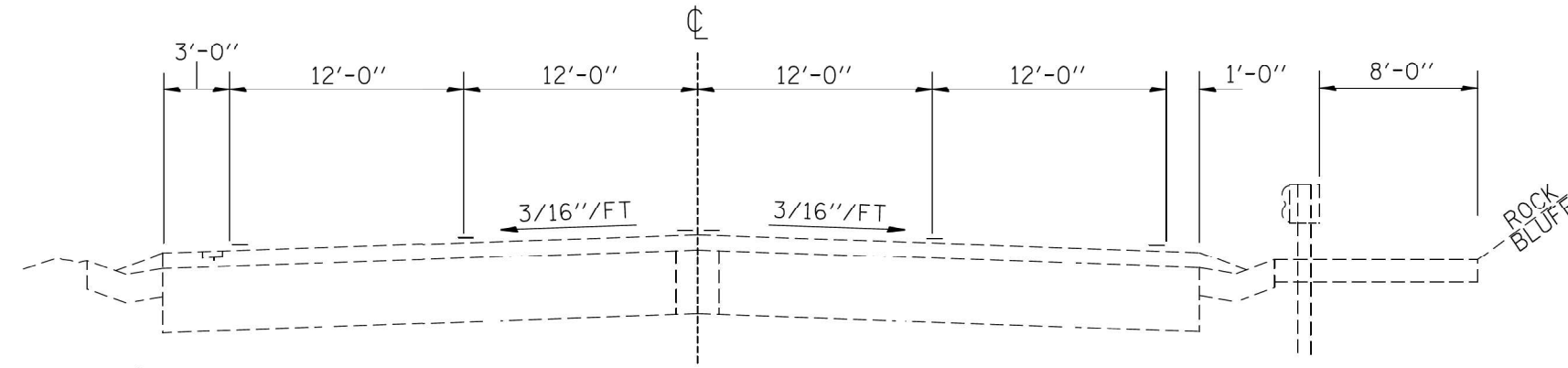

TYPICAL SECTION
M.S. 0.685 TO M.S. 0.801

MODEL: typical1 (Sheet)
FILE NAME: c:\p\work\lewis\skad0892589\0876172-sh1-typical.dgn

USER NAME = Kevin.Lewis	DESIGNED -	REVISED -
	DRAWN -	REVISED -
	CHECKED -	REVISED -
PLOT DATE = 8/13/2024	DATE -	REVISED -

STATE OF ILLINOIS
DEPARTMENT OF TRANSPORTATION

TYPICAL SECTIONS			
IL 100: HOFFMAN GARDENS TO US 67			
SCALE:	SHEET 1	OF 8 SHEETS	STA. TO STA.

F.A. RTE.	SECTION	COUNTY	TOTAL SHEETS	SHEET NO.
VAR	DIST 8 LITTER REMOVAL 2025-1	VARIOUS	15	7
			CONTRACT NO. 76U12	
		ILLINOIS FED. AID PROJECT		

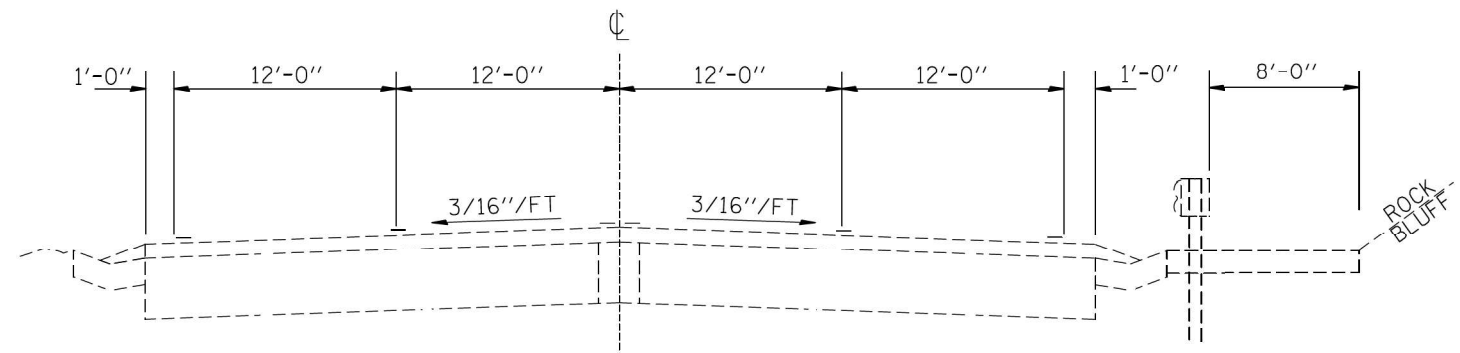

TYPICAL SECTION
M.S. 0.801 TO M.S. 0.910

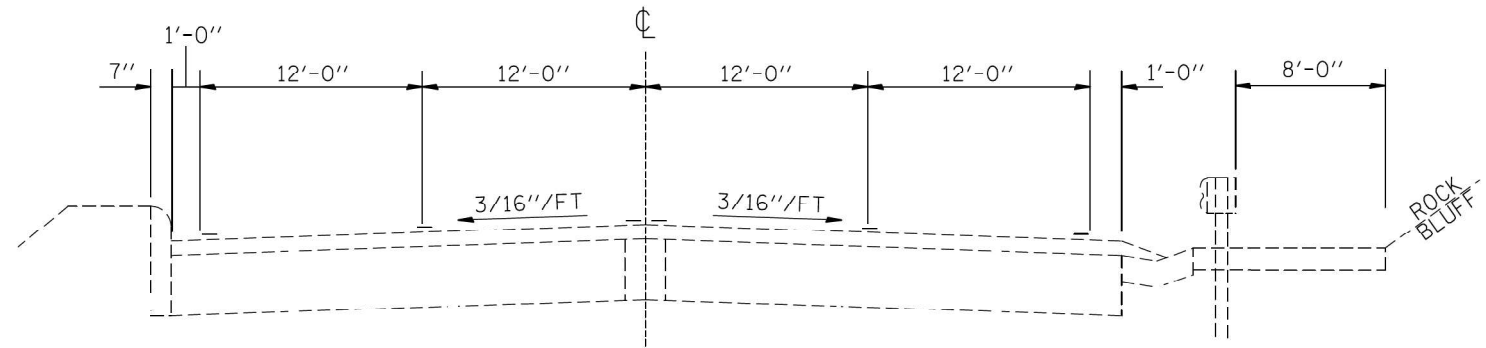

TYPICAL SECTION
M.S. 0.910 TO M.S. 1.062

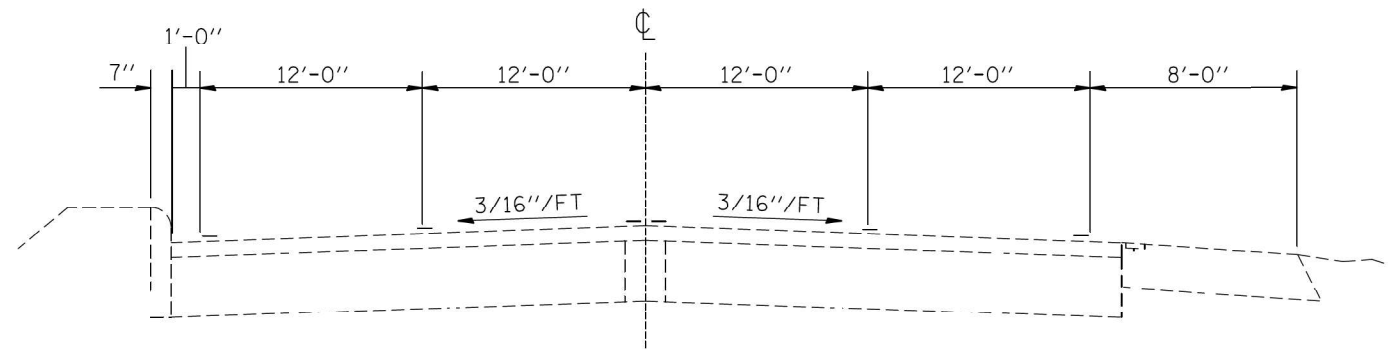

TYPICAL SECTION
M.S. 1.062 TO M.S. 1.26

MODEL: typical2 (Sheet)
FILE NAME: c:\p\work\lewis\lewis\kad0892589\0876117-shit-typical.dgn

USER NAME = Kevin.Lewis	DESIGNED -	REVISED -
	DRAWN -	REVISED -
	CHECKED -	REVISED -
PLOT DATE = 8/13/2024	DATE -	REVISED -

STATE OF ILLINOIS
DEPARTMENT OF TRANSPORTATION

TYPICAL SECTIONS
IL 100: HOFFMAN GARDENS TO US 67

SCALE: SHEET 2 OF 8 SHEETS STA. TO STA.

F.A. RTE.	SECTION	COUNTY	TOTAL SHEETS	SHEET NO.
VAR	DIST 8 LITTER REMOVAL 2025-1	VARIOUS	15	8
			CONTRACT NO. 76U12	
ILLINOIS FED. AID PROJECT				

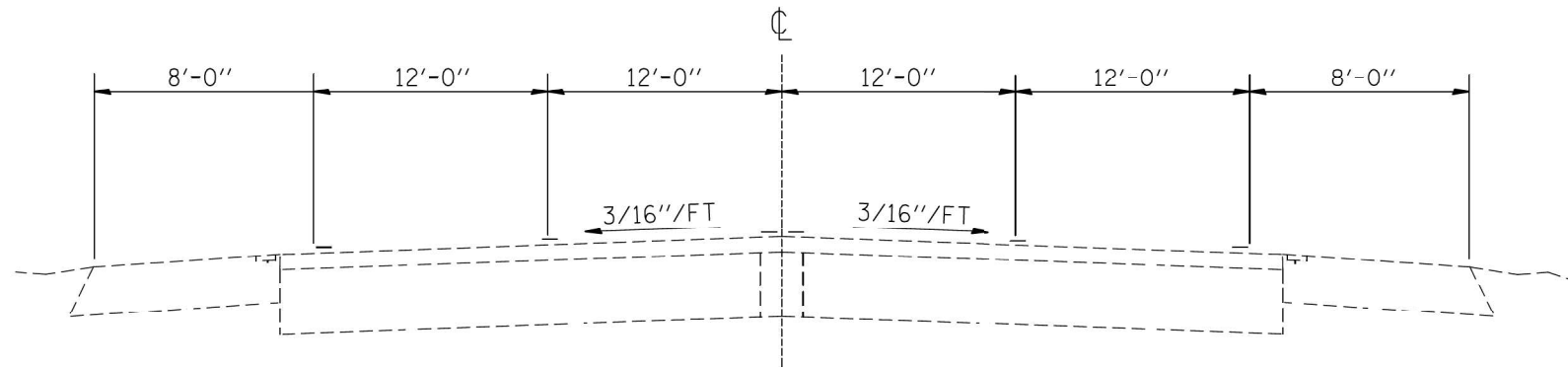

TYPICAL SECTION
M.S. 1.260 TO M.S. 1.319

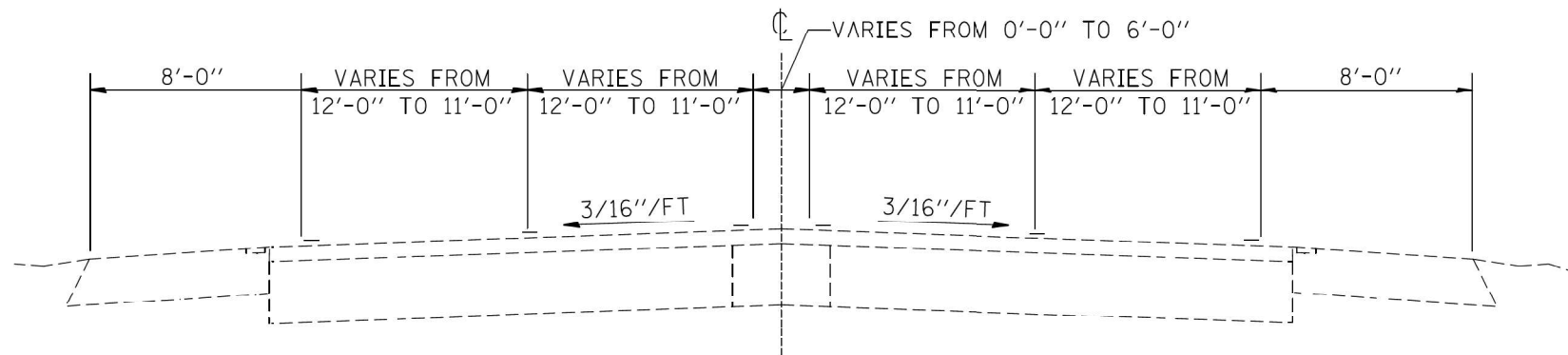

TYPICAL SECTION
M.S. 1.319 TO M.S. 1.346

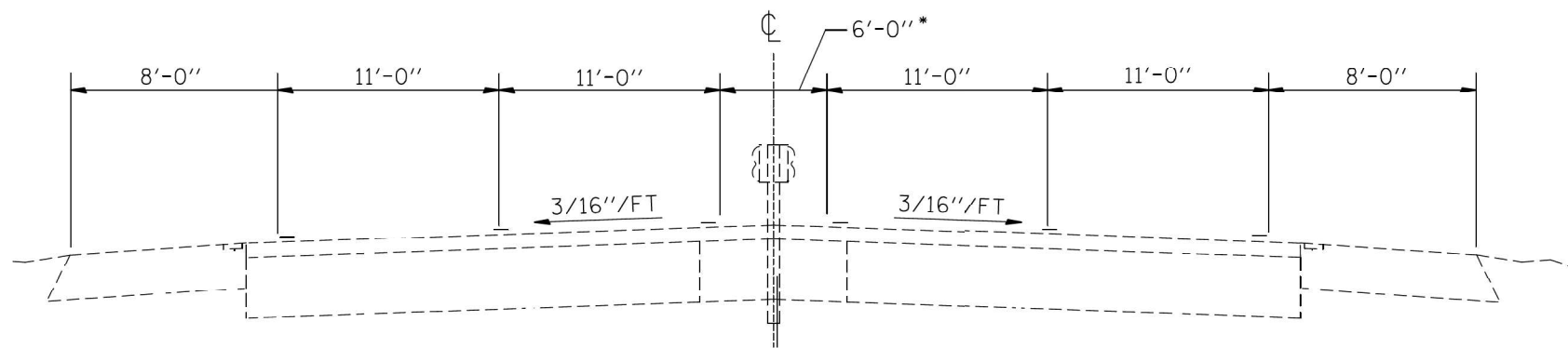

TYPICAL SECTION
M.S. 1.346 TO M.S. 5.439



RAIL ROAD OMISSION DETAIL (N.T.S.)

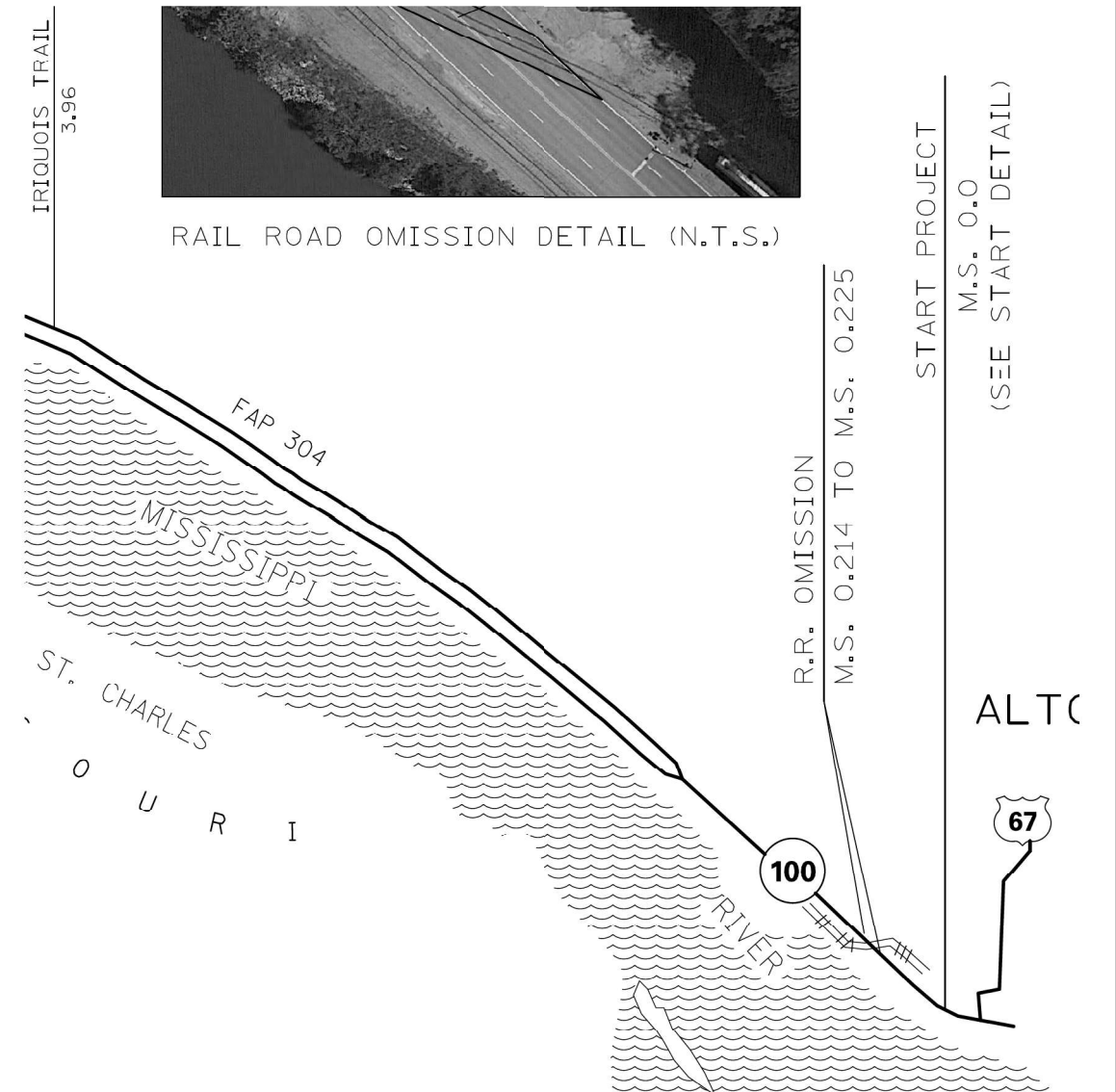

MODEL: typical3 (Sheet)
FILE NAME: c:\p\work\lewis\skad0892599\0876\12-shd-typical.dgn

USER NAME = Kevin.Lewis	DESIGNED -	REVISED -
	DRAWN -	REVISED -
	CHECKED -	REVISED -
PLOT DATE = 8/21/2024	DATE -	REVISED -

STATE OF ILLINOIS
DEPARTMENT OF TRANSPORTATION

TYPICAL SECTIONS
IL 100: HOFFMAN GARDENS TO US 67

SCALE: SHEET OF 8 SHEETS STA. TO STA.

F.A. RTE.	SECTION	COUNTY	TOTAL SHEETS	SHEET NO.
VAR	DIST 8 LITTER REMOVAL 2025-1	VARIOUS	15	9
CONTRACT NO. 76U12				
ILLINOIS FED. AID PROJECT				

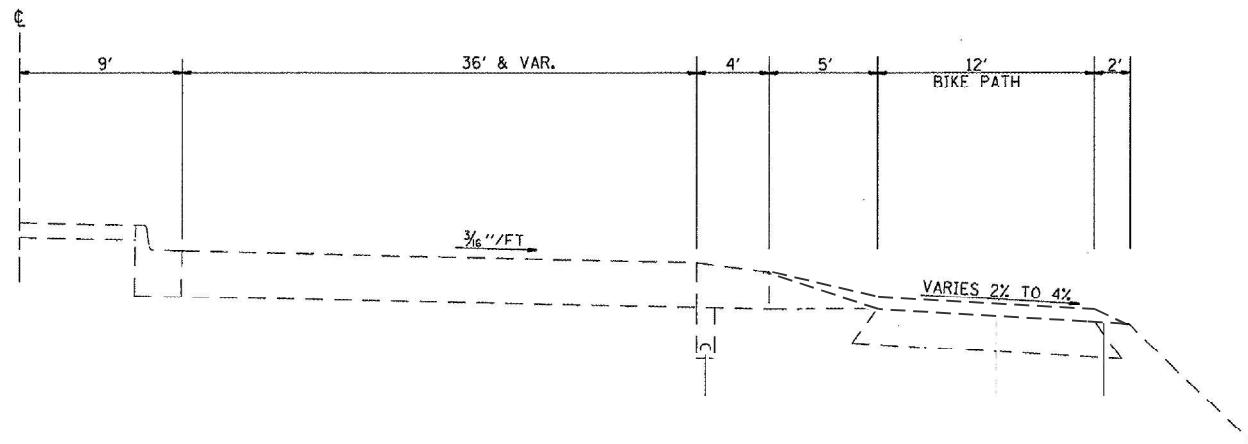

CROSS SECTION
(US 67)
STA. 57+37.08 TO STA. 58+38.20

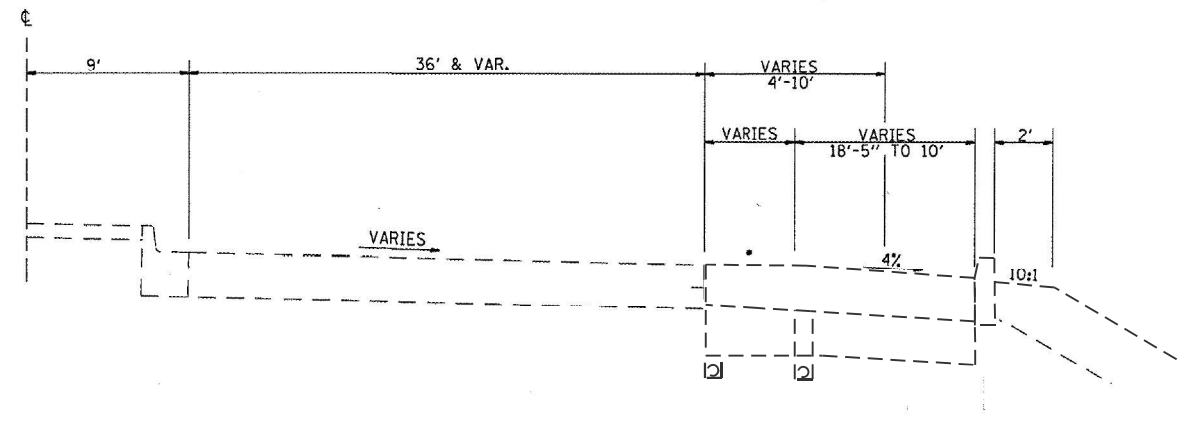

CROSS SECTION
(US 67)
STA. 58+38.20 TO 59+27.40

*MATCH EXISTING ROADWAY SLOPE

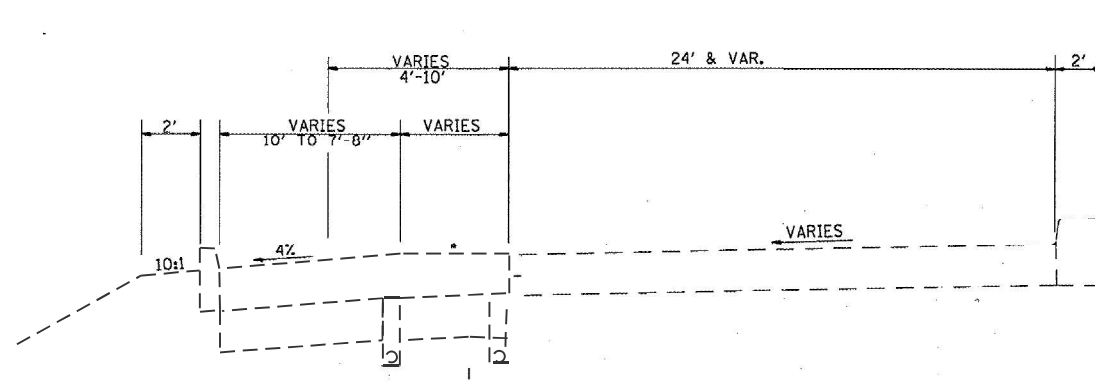

CROSS SECTION
(US 67 TO CLARK BRIDGE)
STA. 254+61.12 TO 255+69.50

*MATCH EXISTING ROADWAY SLOPE

MODEL: typical4 (Sheet)
FILE NAME: c:\p\work\lewis\skid0892589\0876112-shit-typical.dgn

USER NAME = Kevin.Lewis	DESIGNED -	REVISED -
	DRAWN -	REVISED -
	CHECKED -	REVISED -
PLOT DATE = 8/21/2024	DATE -	REVISED -

STATE OF ILLINOIS
DEPARTMENT OF TRANSPORTATION

TYPICAL SECTIONS
US 67: IL 100 TO IL 143

SCALE: SHEET OF 8 SHEETS STA. TO STA.

F.A. RTE.	SECTION	COUNTY	TOTAL SHEETS	SHEET NO.
VAR	DIST 8 LITTER REMOVAL 2025-1	VARIOUS	15	10
CONTRACT NO. 76U12				
ILLINOIS FED. AID PROJECT				

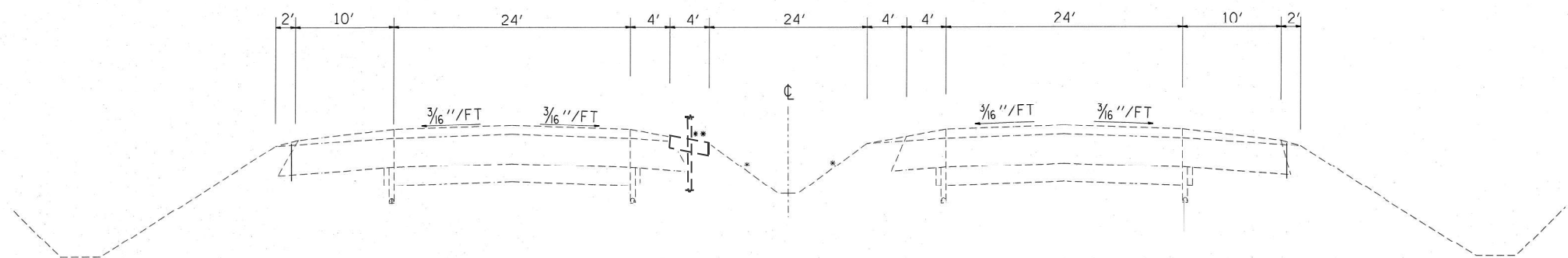

TANGENT SECTION

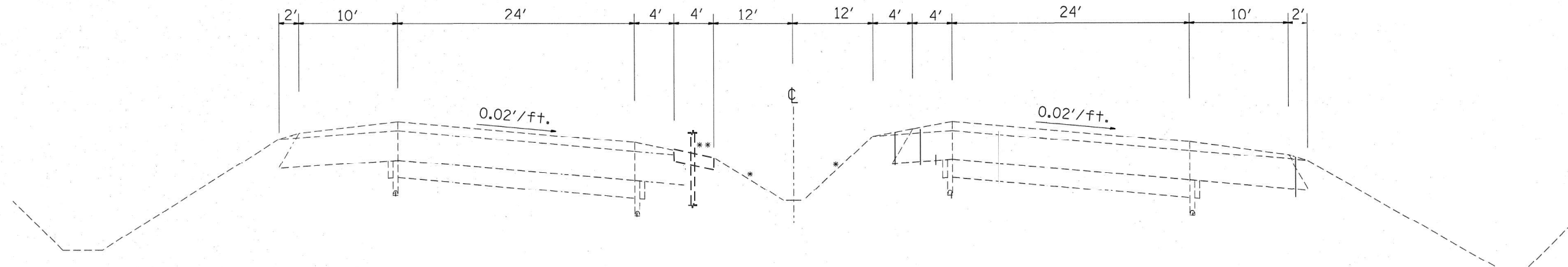

SUPERELEVATED SECTION

MODEL: typical15 (Sheet)
FILE NAME: c:\p\work\lewis\skad0892589\0876112-shit-typical.dgn

USER NAME = Kevin.Lewis	DESIGNED -	REVISED -
	DRAWN -	REVISED -
	CHECKED -	REVISED -
PLOT DATE = 8/22/2024	DATE -	REVISED -

STATE OF ILLINOIS
DEPARTMENT OF TRANSPORTATION

TYPICAL SECTIONS			
I-270: MISSISSIPPI RIVER TO IL3			
SCALE:	SHEET	OF 8 SHEETS	STA. TO STA.

F.A. RTE.	SECTION	COUNTY	TOTAL SHEETS	SHEET NO.
VAR	DIST 8 LITTER REMOVAL 2025-1	VARIOUS	15	11
CONTRACT NO. 76U12				
ILLINOIS FED. AID PROJECT				

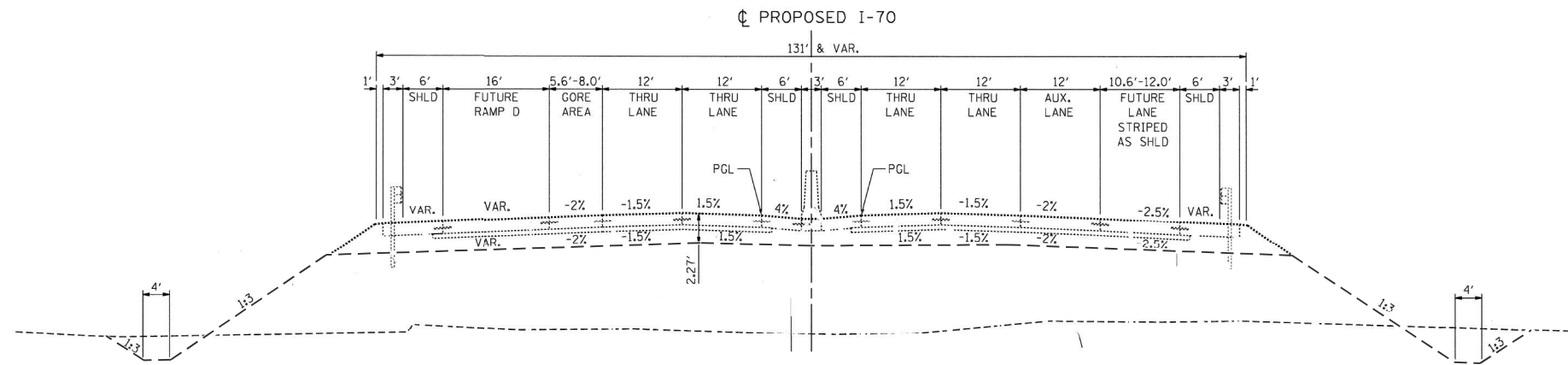

PROPOSED I-70 TYPICAL SECTION
 STA. 147+35.00 TO STA. 149+66.77
 SUPERELEVATION TRANSITION
 STA. 147+65.00 5.4% TO STA. 150+04.60 N.C.

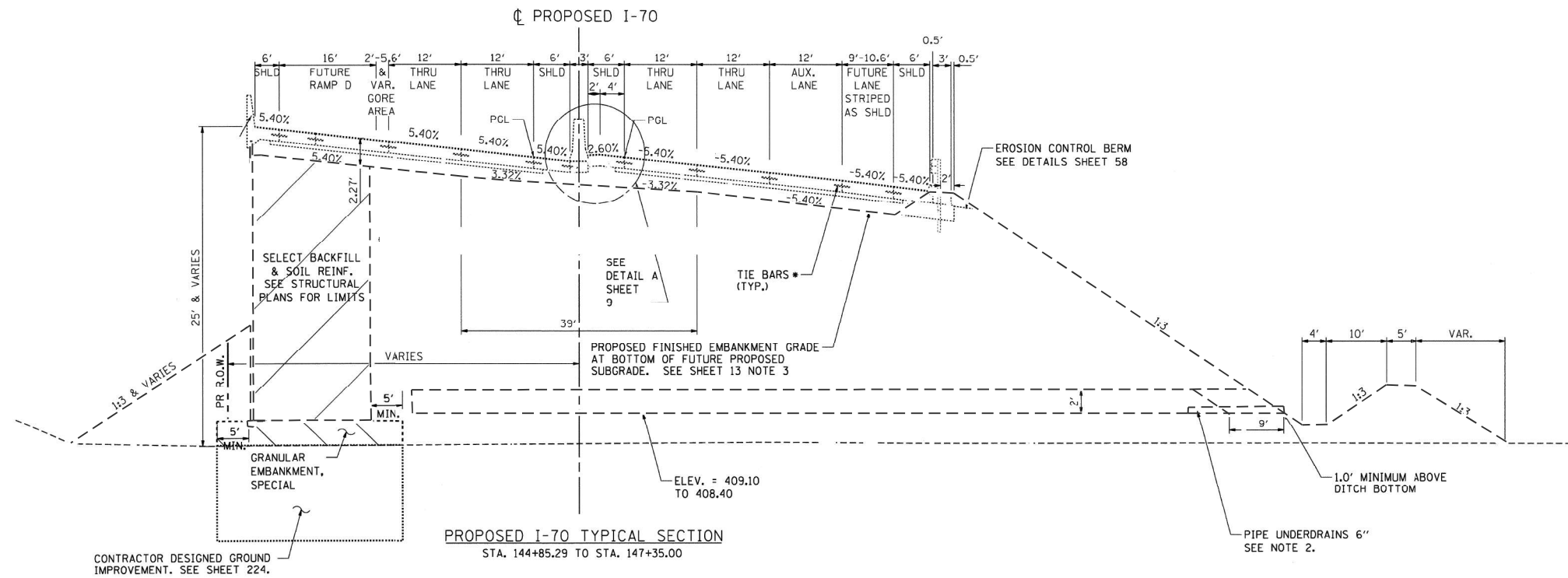

PROPOSED I-70 TYPICAL SECTION
 STA. 144+85.29 TO STA. 147+35.00

MODEL: typical16 (Sheet)
 FILE NAME: c:\p\work\p\lewis\skad0892599\08761172-sh1-typical.dgn

USER NAME = Kevin.Lewis	DESIGNED -	REVISED -
	DRAWN -	REVISED -
	CHECKED -	REVISED -
PLOT DATE = 8/22/2024	DATE -	REVISED -

STATE OF ILLINOIS
DEPARTMENT OF TRANSPORTATION

TYPICAL SECTIONS
I-70 MISSISSIPPI TO I-55/64

SCALE: SHEET OF 8 SHEETS STA. TO STA.

F.A. RTE.	SECTION	COUNTY	TOTAL SHEETS	SHEET NO.
VAR	DIST 8 LITTER REMOVAL 2025-1	VARIOUS	15	12
CONTRACT NO. 76U12				
ILLINOIS FED. AID PROJECT				

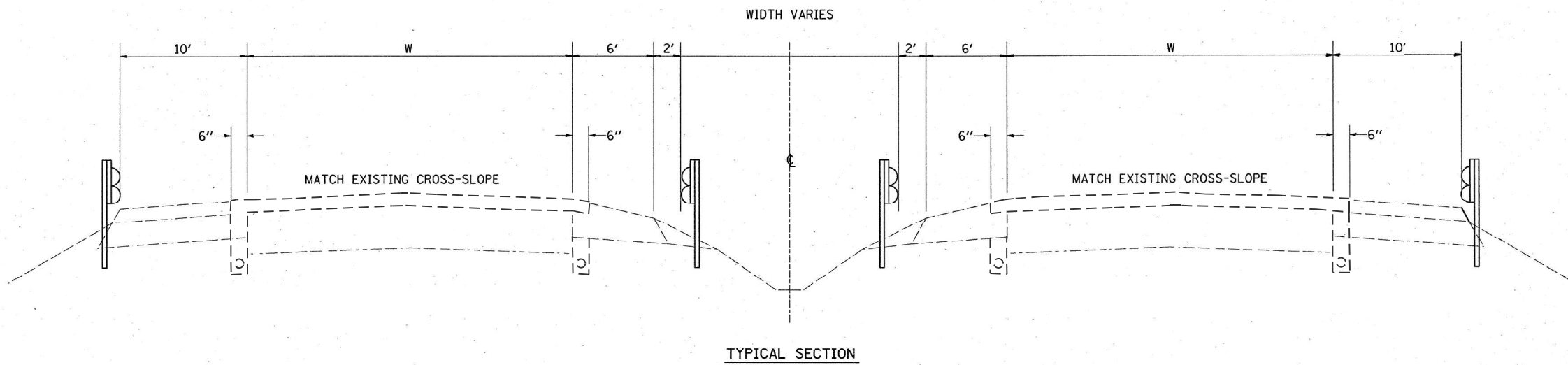

MODEL: typical7 (Sheet)
 FILE NAME: c:\p\work\lewis\kald0892589\0876172-shit-typical.dgn

USER NAME = Kevin.Lewis	DESIGNED -	REVISED -
	DRAWN -	REVISED -
	CHECKED -	REVISED -
PLOT DATE = 8/22/2024	DATE -	REVISED -

**STATE OF ILLINOIS
 DEPARTMENT OF TRANSPORTATION**

TYPICAL SECTIONS			
I-55/64: MISSISSIPPI RIVER TO I-70			
SCALE:	SHEET	OF 8 SHEETS	STA. TO STA.

F.A. RTE.	SECTION	COUNTY	TOTAL SHEETS	SHEET NO.
VAR	DIST 8 LITTER REMOVAL 2025-1	VARIOUS	15	13
CONTRACT NO. 76U12				
ILLINOIS FED. AID PROJECT				

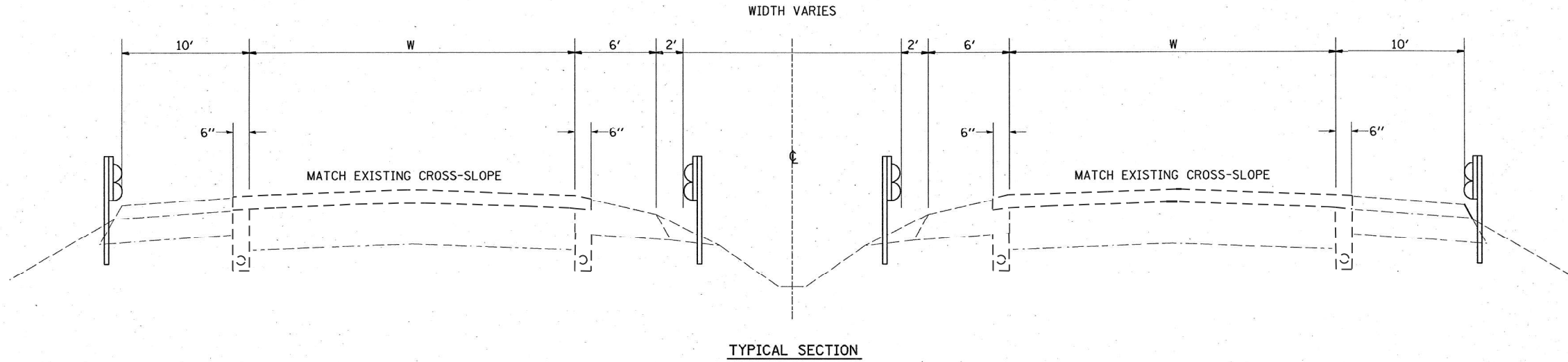

MODEL: typical8 (Sheet)
 FILE NAME: c:\p\work\lewis\skad0892589\0876112-shit-typical.dgn

USER NAME = Kevin.Lewis	DESIGNED -	REVISED -
	DRAWN -	REVISED -
	CHECKED -	REVISED -
PLOT DATE = 8/22/2024	DATE -	REVISED -

STATE OF ILLINOIS
DEPARTMENT OF TRANSPORTATION

TYPICAL SECTIONS
I-255: MISSISSIPPI RIVER TO IL 3

SCALE: SHEET OF 8 SHEETS STA. TO STA.

F.A. RTE.	SECTION	COUNTY	TOTAL SHEETS	SHEET NO.
VAR	DIST 8 LITTER REMOVAL 2025-1	VARIOUS	15	14
CONTRACT NO. 76U12				
ILLINOIS FED. AID PROJECT				

MADISON COUNTY	
LOCATION	MILES
IL 100: HOFFMAN GARDENS TO US 67	2.82
US 67: IL 100 TO IL 143	0.83
I-270: MISSISSIPPI RIVER TO IL3	2.90
TOTAL	6.55

ST. CLAIR COUNTY	
LOCATION	MILES
I-70: MISSISSIPPI RIVER TO I-55/64	2.80
I-55/64: MISSISSIPPI RIVER TO I-70	3.07
TOTAL	5.87

MONROE COUNTY	
LOCATION	MILES
I-255: MISSISSIPPI RIVER TO IL 3	3.21
TOTAL	3.21

MODEL: schedules (Sheet)
FILE NAME: c:\p\work\lewis\skad0892589\0876112-sh-schedule.dgn

USER NAME = Kevin.Lewis	DESIGNED -	REVISED -
	DRAWN -	REVISED -
	CHECKED -	REVISED -
PLOT DATE = 7/16/2024	DATE -	REVISED -

**STATE OF ILLINOIS
DEPARTMENT OF TRANSPORTATION**

LITTER PICKING SCHEDULE

SCALE: SHEET OF 1 SHEETS STA. TO STA.

F.A. RTE.	SECTION	COUNTY	TOTAL SHEETS	SHEET NO.
VAR	DIST 8 LITTER REMOVAL 2025-1	VARIOUS	15	15
			CONTRACT NO. 76U12	
			ILLINOIS FED. AID PROJECT	